

1861

**THORPE'S    DICTIONARY**  
**OF**  
**APPLIED    CHEMISTRY**  
**IX**

*Editorial Board:*

**SIR IAN HEILBRON, D.S.O., D.Sc, LL.D., F.R.S.**

*{Chairman}*

**H. J. EMELEUS, D.Sc, A.R.CS. , D.I.G., F.R.I. C., F.R.S.**

**H. W. MELVILLE D.'Sc, Ph.D., F.R.S**

**A. R. TODD, D.Sc, D.Phil., LL.D^JF.fe.S.**

*Editor:*

**M. A. WHITELEY, O.B E., D.Sc., F.R.I.C.**

*Assistant Editors:*

**A. J. E. WELCH, Ph.D., A.R. C.S., D.I.G .**

**L. N. OWEN, D.Sc, Ph.d., F.R.LC.**

THORPE'S DICTIONARY  
OF  
APPLIED CHEMISTRY

150.1

FOURTH EDITION  
(Revised and; Enlarged)

**VOL. IX**

**Oils, Fatty—Pituitary Body**

With an index by Dr. J. N. Goldsmith

*WITH ILLUSTRATIONS*



LONGMANS, GREEN AND CO.  
LONDON • NEW YORK • TORONTO

**LONGMANS, GREEN AND CO LTD**

*6 &c 7* CLIFFORD STREET LONDON W X

ALSO AT MELBOURNE (AM) CAPE TOWN

**LONGMANS, GREEN AND CO INC**

55 FIFTH AVENUE NEW YORK 3

**LONGMANS, GREEN AND CO**

**215** VICTORIA STREET TORONTO 1

**ORIENT LONGMANS LTD\***

BOMAA Y CALCUTTA MADRAS

FOURTH EDITION . . . • 1949  
NEW IMPRESSION . . . - 1951



# LIST OF CONTRIBUTORS

## TO VOLUME IX

---

- E. B. ABBOTT, *see* E. H. RODD.
- JAMES BADDILEY, M.Sc, Ph.D., *Imperial Chemical Industries Fellow, University of Cambridge.* [OXALIC ACID.]
3. W. FARRETT, B.Sc, Ph.D., F.R.I.C, *Assistant Director of Research, Exploratory and Applied Dept., Minton Chemicals, Ltd.* [PHTHALIC ACID.]
- CHARLES THOMAS BENNETT, B.Sc.(Lond.), F.R.I.C, *Pharmaceutical Chemist, Chief Chemist to Wright, Layman and Upiney, Ltd., 46, Southwark Street, S.E.1.* [OLEO-RESINS]
- R. PENLEY, Ph.D., M.C.A., R.I.C [PARABANIC ACID ; PHENYLACETIC ACID ; PHENYLALANINE.]
- £ BERGEL, D.Sc, D.Phil.nat.(Breiburg), Ph.D.(Lond.), F.R.I.C, *Director of Research, Roche Products, Uden Garden City, Herts.* [P-VITAMIN.]
- GEORGE BLOOMFIELD, Ph.D., D.I.C., F.R.I.C, *British Rubber Producers Research Association, 48, Tewin Road, Welwyn Garden City, Herts.* [OZONIDES ; PEROXIDES AND PERACIDS, ORGANIC.]
- Dr. E. J. BOWEN, M.A., D.Sc, F.R.S. [PHOTOCHEMISTRY ; PHOTOSYNTHESIS IN PLANTS.]
- Dr. A. J. BRADLEY, F.R.S. [ORDER-DISORDER TRANSFORMATION IN ALLOYS.]
- WILLIAM BRADLEY, *Professor of Colour Chemistry and Dyeing, The University, Leeds.* [OXY-OCTOYANIN; PELARONENIN; PELARONIDIN; PELARONIN; PELTOYNYDIN; PELTOGYNOL; PEONIDIN; PIONIN; PETUNIDIN; PETUNIN; PHARITIDIN.]
- H. G. BRAY, B.Sc, Ph.D., *lecturer in Biochemistry, University of Birmingham.* [PAFAIN ; PEPSIN.]\*
- H. T. S. BRITTON, D.Sc.(Lond. and Bristol), D.I.C, F.R.I.C, *Professor of Chemistry, Washington Singer Laboratories, University College of the South West, Exeter.* [OXIDATION-REDUCTION POTENTIALS & pH VALUES : THEIR SIGNIFICANCE]
- H. TREEVES BROWN, B.Sc, Ph.D.; \ LESTER SMITH, D.Sc, F.R.I.C, *Ohxo Laboratories, Ltd., Oreenford, Middlesex;* A.H.CAMPBELL, B.Sc., Ph.D., *Glaxo Laboratories, Ltd., Msrmentation Division, Barnard Castle.* [PENICILLIN.]
- A H. CAMPBELL, *see* H. TREEVES BROWN.
- H. C. CARRINGTON, *see* S. ELUNGWORTH.
- S.\*COFFEY, D.Sc.(Leiden), M.Sc.(Lond.), *F.R.I.C, Imperial Chemical Industries, Ltd. (Dyestuffs Division), Blackley, Manchester* [OXAZINE DYE STUFFS.]
- E- J. CROSS, Ph.D., R.B.I.C, *Senior Lecturer in Colour Chemistry in the University of Leeds.* [OLD FUSTIC ; ONJMA EOHIOIDES; OSAGE ORANGE TREE ; PERSIAN BERRIES ; PHLORETIN ; EPCEN; PIOROROELLIN.]
- F- H. CURD, *see* S. ELUNGWORTH.
- STEPHEN F. EDGE, M.A., F.R.I.C [PAPER MAKING.]
- ^ GUSTAV EGLOFF, D.Sc., *Director of Research, Imperial Oil Products Company.* [PETROLEUM.]
- 5- ELLINGWORTH, M.Sc; H7C. CARRINGTON, B.Sc, Ph.D.; F. H. S. SURD, B.Sc., Ph.D.; F. L. ROSE, B.Sc, VKD., *Imperial Chemical Industries, Ltd., Blackley, Manchester, 9.* [19 Definitive Articles on Synthetic Drugs.]
- 18- V. EVANS, O.B.E., D.Sc. [PITCH.]
- U- H. EVA&S. M.A., Sc.D.(Cantab.), Sc.D.(Causa Honoris, Dublin). [PASSIVITY.]

- E., H. FARMER, D.Sc, F.R.S.,** *Assistant Director of Research, British Rubber Producers' Research Association, Welwyn Garden City, Herts.* [OLEBTNS.]
- GEOFFREY GEE, Sc.D.(Cantab.),** *Director of Research, British Rubber Producers Research Association.* [OSMOTIC PRESSURE.]
- J. N. GOLDSMITH, Ph.D., M.Sc, F.R.I.C.** [OPIANOIC ACID ; PALM SUGAR ; PAVDOL ; PARCHMENT ; PARCHMENT PAPER ; PARSLEY, ESSENTIAL AND FATTY OIL OIL ; PINCHBECK ; PIPERONAL ; and 11 Definitive Articles.]
- NORMAN H. HADDOCK,** *see R. P. LINSTEAD.*
- W. E. HAMER, M.Sc, A.R.I.C.,** *Assistant Director of Research (Process and Pilot Plant Division), Monsanto Chemicals, Ltd., Ruabon, North Wales.* [PHENOL AND ITS HOMOLOGUES.]
- T. W. HARRISON, B.Sc, F.R.I.C.,** *Superintending Chemist, Government Laboratory (Retired).* [PARAGUAY TEA.]
- A. HICKLING, M.Sc., Ph.D., F.R.I.C.,** *Senior Lecturer in Physical Chemistry, University of Liverpool.* [OVERPOTENTIAL.]
- T. P. HILDITCH, D.Sc, F.R.I.C., F.R.S.,** *Campbell Brown Professor of Industrial Chemistry, University of Liverpool.* [OILS (FATTY) AND FATS.]
- L. M. HILL,** *Imperial Chemical Industries, Ltd., Research Department of Alkali Division, Northwich.* [PHASE RULE : APPLICATION TO THE SEPARATION OF SALT SOLUTIONS INTO THEIR CONSTITUENTS.]
- Professor E. L. HIRST, M.A., D.Sc, F.R.I.C., F.R.S.E., F.R.S.,** *Professor of Organic Chemistry at the University of Edinburgh;* **J. K. N. JONES, D.Sc, A.R.I.C.,** *Senior Lecturer in Organic Chemistry, The University of Bristol.* [PECTIN.]
- C. R. HOUSEMAN, B.A.,** *British Oxygen Co., Ltd.\*.* [OXYGEN, APPLICATION ; OXYGEN, PRODUCTION.]
- H. L. HOWARD,** *see T. DRUMMOND KERR.*
- D. J. G. IVES, A.R.C.S., D.Sc, F.R.I.C.,** *Reader in Chemistry, Rirkhuk College, University of London.* [ON SAGER ELATION ; OSTWALD DILUTION LAW.]
- T. H. JAMES,** *see C. H. SMITH.*
- R. G. JOHNSTON,** *see H. E. WATT.*
- J. K. N. JONES,** *see E. L. HIRST.*
- T. DRUMMOND KERR, W. Symonds, Ltd., and H. L. HOWARD, B.Sc., A.R.C.S., D.I.C., M.I.Chem.E., F.R.I.C.,** *Head of Department of Science, East Ham Technical College, Consultant on Paint Technology.* [PIGMENTS AND LAKES.]
- Dr. JOHN G. KIRKWOOD,** *Arthur Amos Noyes Professor of Chemistry, California Institute of Technology, Pasadena, California.* [OPTICAL ACTIVITY.]
- J. A. KITCHENER, Ph.D.,** *Lecturer in Physical Chemistry, Imperial College of Science and Technology, London, S.W.1.* [ORTHOBARIO PENSITY.]
- G. A. R. KON, M.A.(Cantab.), D.Sc.(Lond.), F.R.S.,** *Professor of Chemistry, Chester Beatty Research Institute, Royal Cancer Hospital (Free), London, S. W.3.* [PIWJITARY BODY.]
- WILFRED H. LINNELL, M.Sc, D.Sc, Ph.D., F.R.I.C.,** *Professor of Pharmaceutical Chemistry, University of London.* [PELLETIERINE.]
- R. P. LINSTEAD, C.B.E., M.A., D.Sc, F.R.I.C., F.R.S.; NORMAN H. HADDOCK; B.Sc, A.R.I.C.,** *Imperial Chemical Industries, Ltd. (Dyestuffs Division).* [PHTHALOCYANINES.]
- B. LYTHGOE, M.A., Ph.D.** [ORITHTHINE.]
- FREDERICK GEORGE MANN, Sc.D.(Cantab.), D.Sc.(Lond.), F.R.S.,** *Reader in Organic Chemistry in the University of Cambridge.* [PARAXANTHINE ; PHOSPHORUS, ORGANIC DERIVATIVES OF.]
- M. L. MEARA, B.Sc, Ph.D., F.R.I.C.,** *Lecturer in Industrial Chemistry, The University, Liverpool* [ORNICIA ON ; OLIVE OIL.]
- S. T. MINCHIN, B.Sc, F.Inst.Pet.** [PETROLEUM WAXES.]

- "A\* MPELWYTF-HUGHES, D.Sc.(Liverpool), D.Phil.(Oxon.), Ph.D.(Cantab.), *University Lectnr in Physical Chemistry, Cambridge.* [PARTIAL M<sup>3</sup>SLAB QUANTITIES; PARTITION FUNCTION.]
- THOMAS MOLACHLAN, A.C.G.F.C., P.R.I.C. [PEPPER; PIMENTO.]
- K. ^ N2WHQTJSE, A.M.I.£.E., *Development Dept., Marconi Instruments, Ltd.* [pH, COM-MERIOAL APPARATUS FOR THE DETERMINATION OF.]
- E. JS.CNOBLE, B.Sc, Ph.D., A.R.I.C., *Assistant Development Manager, Imperial Chemical Industries, Ltd., (Paints Division)* [PAINTS.]
- D. S. PAYNE, Ph.D., A.R.C.S., A.R.I.C., *Lecture^ in Chemistry in the University of Glasgow.* [OXYGEN ; OZONE ; PEROXIDES AND PERAOIDS, INORGANIC.]
- A. G. POLLARD, A.R.C.S., D.I.C., B.Sc, F.R.I.O., *Lecturer in Agricultural Chemistry, Imperial College of Science and Technology, London, 8.W.T.* [OERA; OLIVE', ONION; ORANGE; PARLEY; PARSNIPS; PAW-PAW; PEA: PEA6H; PEAR; PERSIMMON; PINEAPPLE.]
- ALAN ft., POWELL, MJLM., *Research Manager, Johnson MaUhey and %Co. Ltd.* [OSMIUM ; PALLADIUM.]
- ?r67essor J. H. QWASTEL, J>%Sc.(Lond.), Ph.D.(Cantab.), A.R.O.S.(Lond.), F.R.I.C, F.C.I.C, F.I.S.. *Professor of Biochemistry, SScQill University, Montreal.* [OXIDISING ENZYMES.]
- B. RAISTKICK, *see JB TOPLEY.*
- F. A. ROBINSON, M.So.Tech., LL.«., F.R.I.C., *Research Department, The Distillers Company, Ltd.? G?eat Burgh, Epsom.* [PATULIN.]
- E. fl. RODD, D.Sc.(Lond.), A.C.G.I., D.I.C., F.R.I.C.; E. B. ABBOTT, Ph.D., *Imperial Chemical Industries, Ltd. (Dyestuffs Division), Blackley, Manchester.* [PHOTOSENSITIVITY OF DYESWJFFS.]
- F. L. ROSE, *see S. ELLDTGWORTH.*
- Protessor J. L. SIMONSEN, P.Sc, F.R.I.C., B^R.S., *Director of Research, Colonial Products Research Council, South Kensington, London, S.W.I.* [ORTHODENE ; PARMONE ; PATCHOULI ALCOHOL ; PERILLYL ALCOHOL ; PHELLANDRAL ; a- and J8-PH^LLANDRENE ; PIPSRONAL ; O- AND 0-PINENE; PINfJNjyS; PINOCAMPHrOL; PINOCAMPHOL; PINOOAMPHONE ; PINO-OARVEOL; PINÓOARVONE; PIPEEITOL; PIPERITONE.]
- D. G. SKINNER, M.Sc, Ph.D.(Birm.), *formerly of the British Colliery Owners Research Associa-tion.* [PARTICLE SIZE IN THE SUB-SIEVE RANGE, MEASUREMENT OF.]
- C H. SMITH, B.§0., & TL.V.S., <*Research Laboratory, Efidak, Ltd., London* ; T. H. JAMES, Ph.D., *Research Laboratories, Eastman Kodak Co.* [PHOTOGRAPHY.]
- E. LESTER SMITH, *see H. TREEVES BROWN.*
- J. SPENCER, MA., Sc.D., F.R.S., *Editor of the ^4^Minet-ological Magazine," formerly Keeper of Minerals in the British Museum.* [QLIVENITE; ONYX; ORANGITE ; OTAVITE.]
- ^fessor S. SUGD^N, A.R.C.S0., D.Sc, F.R.I.C., F.R.S. [PAB^OHORJ
- B. ^OPLEY, M.A.; B. RAISTRICK, Ph.D., *Albn^U and WHson^IAd., Oldbury, Birmingham,* [PHOSPHORUS.]
- HENRY tf. WATT, D.Sft, F.R.I.C., 5, *Drumsheugh Gardens, Edinburgh,\** ; R. G. JOHNSTON, M.A., B.So., Ph.D>X and H. Smith, Ltd., *Blandfield Chemical Works, WheatfUld Road, Edinburgh, 11.^* [OPIUM.]
- B. C. L^WEEDON, Ph.D., A.R.C.S., D.I.C., A.R.I.C., *Lecturer in Organic Chemistry, Imperial OolUge 04 Science and Technology, London, S. W.I.* [PH^ANTHRENE.]
- T. F. WEST, B.Sc, Ph.D.(Lond.), ^R-LC, *Assistant Director, Onk&o Research Foundation, Toronto, Canada.* [PERFUMES, SYNTHETIC]
- W. B. WHALLEY,,Ph.D., A.R.I.C., *Lecturer in Organic Chemistry, Liverpool ^University.* [PIOROTOXIN.]
- DAVID WILLIAMS, B.Eng., M.So., D.I.C., M.Inst.M.M., F.G.S., *Professor of Mining Geology, University of London.* [OLIVINE; OOLITE; OPAL; ORPIMENT; ORTHITE; OZOKERITE; PARGONITE; PEARLANDITE; PICALITE; PIRRITE; PIRNACITE; PROSPERITE ROCK; PITCH-BLENDE.]

## LIST OF CONTRIBUTORS.

- K. A. WILLIAMS, B.Sc., Ph.D., M.Inst.Pet., F.R.I.C.,** *Consulting and Analytical Chemist* (OILS (FATTY) AND FATS, TECHNICAL ANALYSIS OF.)
- R. J. WILLIAMS, Professor of Chemistry, Director, Biuchemical Institute, The University of Texas, Austin.** [PANTOTHENIO ACID.]
- F. N. WOODWARD, B.Sc, Ph.D., F.R.I.C, Director, U.K. Scientific Mission, Washington, D.C. Scientific Adviser to the U.K. High Commissioner for Canada. War-time Secretary of the Ministry of Production's Insecticide Development Panel and Interdepartmental Coordinating Committee on Insecticides.** [PEST CONTROL.]

## NOT?

Italicised words in inverted commas may be registered trade names.

## ERRATUM.

In Vol. VIII, p. 644, Table I, last line, *for* -101° *read* 101°.

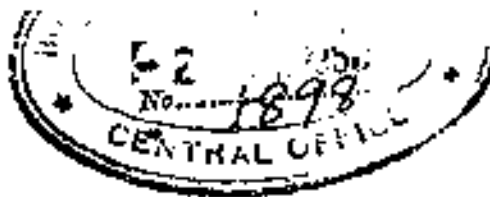

# A DICTIONARY OF APPLIED CHEMISTRY.

O—continued.

**OILS (FATS?) AND FATS.** The materials to be considered are the natural fats of the Vegetable and animal kingdoms, especially those which find important use in the production of edible fats, soaps, or other detergents, paints and varnishes, and in some other industries. The discussion is therefore broadly confined to the natural glycerides (esters of higher fatty acids with glycerol) which form the overwhelming bulk of the industrially useful fats. Other forms of fatty-acid derivatives are found in nature and may accompany the glyceric fats. Such forms include phosphatides, in which a glycerol molecule is combined with two higher fatty-acid radicals, the remaining glyceryl hydroxyl group being united to phosphoric acid which in turn is linked with a nitrogenous base (chlorine or β-aminoethyl alcohol); wax esters, which are esters of higher fatty acids with some of the corresponding higher fatty alcohols, or with sterols (or vitamin-A) or (in a few instances) with a glyceryl higher acyl ether (batyl, sdachyl, chimyl alcohols); and some other more complex substances such as sphingomyelin (cerebrosides, etc.). Although in some cases glyceridic fats (mixtures of mixed glycerides, to which the term *fats* will be restricted throughout this article) are substantially the only lipid substances present in the materials here dealt with, a rigid line of demarcation cannot be drawn. In particular, some of the natural fats are accompanied by waxes of the ester type mentioned. This is notably the case in the sperm-whale oils and a few other fats of marine origin; whilst the small amounts of sterols which usually accompany natural fats, and of batyl, etc., alcohols which are sometimes present, frequently occur in the form of higher fatty esters in the natural state. Sterols and other alcohols, which are usually termed "unsaponifiable constituents," are mainly present in the form of wax esters (or ester-waxes). Ester-waxes in which glycerides are not present, such as the insect wax (eg., beeswax) and vegetable waxes (carnauba wax), are mainly esters of aliphatic alcohols and acids of higher molecular weight than those present in the glyceridic fats; and are outside the scope of this article.

Consideration of the natural fats (triglycerides) is thus complicated to a certain extent by the circumstance that they are frequently accompanied by some of the other lipid groups, usually in very small proportions, but occasionally in larger amounts. It has been complicated further until recently by the terminology applied to the glyceridic fats themselves. Originally, only those natural fats which happened to be solid at the usual temperatures were referred to as fats; those liquid at the usual temperatures were first termed "fixed oils," to distinguish them as a class from the volatile or essential oils (terpene derivatives, etc.) also found in the vegetable kingdom. Even later, the liquid fats have been usually termed oils, or fatty oils, and the usage in the case of well-known specific fats such as linseed oil or cottonseed oil has become so conventional that it must remain. Nevertheless it is desirable for systematic purposes to classify the entire group, as "fats," distinguishing, if desired, between solid fats and liquid fats (the "fatty oils").

## GENERAL NATURE OF NATURAL FATS.

Natural fats occur throughout the vegetable and animal kingdoms from the simplest organisms up to the most highly developed forms of vegetable and animal life, and are present in almost all tissues and organs. In the vegetable kingdom, fats are deposited in largest amounts in the seeds, usually in the endosperm where, with proteins and carbohydrates (starch), they serve as nourishment to the embryo. In some instances the fleshy fruit-coat (pericarp or receptacle) of the seed also contains notable proportions of fat, whilst in certain plants fat is present in some quantity in the tubers or rhizomes. In small proportions, it should be noted in passing, fats are found in all parts of the growing plant, roots, leaves, and fruits, but in most instances it is only in the seed that any high concentration of fat is observed. In animals, fats are usually stored in quantity in certain tissues, notably beneath the skin and around or in some of the intestinal organs. The kidneys are normally surrounded by a layer of fat, and

in some animals (mainly fish) the liver serves as a fat-store as well as being, in all animals, the principal site where fats\* are synthesised and elaborated by the animal. Fats also occur, but often only in minor proportions, in most of the organs and tissues of animals. Finally, in mammals, the milk fats are important members of the group which may differ characteristically in composition from the rest of the animal fats.

From the technological standpoint, the fats of most interest are naturally those available in greatest quantity and concentration in the respective natural organism\*. In the vegetable kingdom, therefore, it is the seed fats and a few fruit-coat fats which are of chief value, especially seed endosperms which are rich in fat and contain, *e.g.*, from 25 to 50% of fatty matter. In the animal kingdom, similarly, the main storage or depot fats are those of greatest industrial value—the adipose tissue fats from the back or rump of domestic animals such as the pig or ox, the blubber of whales, the perinephric fat surrounding the kidneys (lard, suet), and in fishes either flesh fats (*e.g.*, herring) or liver fats (*e.g.*, cod). To these must be added, as already mentioned, the mammalian milk fats (especially butter fat from the cow) on account of their dietary importance.

#### METHODS OF INVESTIGATION OF THE COMPONENTS OF NATURAL FATS.

Natural fats are essentially mixtures of mixed triglycerides and resolution into their component glycerides by physical means is usually impracticable. A typical\* animal body fat, for example, may consist of large proportions of palmitolein and oleopalmitostearin, with lesser quantities of such mixed glycerides as oleodistearin, oleodipalmitin, palmitodistearin, dipalmitostearin, and triolein. The solubilities of many of these components are too similar to permit of any adequate resolution by crystallisation. Nevertheless, as shown below, other methods have been utilised whereby an approximate knowledge of the constituent mixed glycerides can be obtained, at all events when the mixture of fatty acids present in the whole fat is not too complex.

**Component Fatty Acids.**—Whilst the determination of the component glycerides of a fat is a difficult and laborious undertaking, that of the component fatty acids (i.e., the mixture of fatty acids present in combination as glycerides and obtained by quantitative hydrolysis of the fat) can be effected with considerable accuracy, although here also the procedure is lengthy. The method hitherto usually employed has been first to separate the mixed fatty acids from a fat into two groups—those the lead salts of which are insoluble in 5% alcohol, and those the lead salts of which are soluble in this medium. (In the special case of milk fats, which may contain butyric, hexanoic, and octanoic acids, these are removed as far as possible by distillation of the mixed fatty acids in a current of steam before carrying out the lead-salt separation, the steam-volatile acids being recovered and dealt with separately by fractional distillation.) The lead salts of

palmitic, stearic, and higher saturated fatty acids are insoluble in alcohol, those of myristic, lauric, decanoic, and octanoic sparingly (but increasingly) soluble; whilst of the unsaturated acids only the monoethenoid acids of the C<sub>20</sub>, C<sub>22</sub>, and C<sub>24</sub> series, and to a minor extent oleic acid (together with "iso"-acids from hydrogenated fats) form lead salts sparingly soluble in alcohol. On the other side, monoethenoid acids of the C<sub>16</sub> series or lower homologues and all natural polyethenoid acids yield lead salts which are freely soluble in alcohol, whilst, as stated, lead oleate is largely soluble. Consequently this preliminary separation gives (i) one group of fatty acids in which nearly all the palmitic and all the higher saturated acids are present, with part of any myristic or lower saturated acids, a small proportion of oleic and most of any higher monoethenoid acids, and (ii) another group of fatty acids containing, in addition to small amounts of palmitic and lower saturated acids, practically all the unsaturated acids from the original fat. The lead-salt separation has given excellent service although it is not fully effective when the saturated acids form 10% or less of the total acid\* in a fat, or when they consist largely of acids of lower molecular weight than myristic or palmitic. Furthermore, the conversion of the more unsaturated acids into salts and then back to free acids offers opportunities for oxidation or other chemical changes which are better avoided, *e.g.*, by the use of physical rather than chemical methods of separation.

Such a physical method, rapidly coming into use, is the resolution of a mixture of fatty acids into several groups (in which, respectively saturated, monoethenoid, or polyethenoid acids will be largely concentrated) by crystallising it systematically from appropriate solvents over a range of temperatures, usually between -60° and 0°. Acetone is probably the best general solvent, although ether and light petroleum are preferred in specific instances. Crystallisation at -50° to -60° leaves in solution linolenic, linoleic, and other polyethenoid acids with minor amounts of oleic and saturated acids; a temperature of -30° serves as a rule to give fair separation of saturated from oleic and linoleic acids. The best conditions for different mixtures of fatty acids obtained from natural fats must be selected according to the general nature of the mixture and, where necessary, after preliminary trials have been made (*e.g.* Foreman and Brown, *Oil and Soap*, 1944, 21, 183; Hilditch and Biley, *J.S.C.* 1945, 64, 204; 1946, 65, 74; Gunstone and Hilditch, *ibid.* 1946, 65, 8).

The saturated, oleic, linoleic, linolenic, and elostearic acid contents of each group of acids thus obtained by low-temperature crystallisation from fatty oils containing one or more of these polyethenoid acids can be determined from (i) the extinction coefficient  $E_{1\%}^{1\text{cm}}$ \* 268 m/i. (elostearic) and (ii) the extinction coefficients of bands<sup>1</sup> at 268 m/i. (linolenic) and 234 m/i. (linoleic) due to conjugated tri- or diethenoid acids produced by isomeric change<sup>1</sup> when linolenic and linoleic acids are heated under standardised conditions with <sup>1</sup> (Mitchell, Kraybill, and Zscheile, *Ind. Eng. Chem.*

*Chem. [A-b]l.*, 1943, 15, 1; Beadle and Kray-  
J. Amer. Chem. Soc. 1944, 66, 1232;  
Hilaitch, Morton, and Riley, *Analyst*, 1945, 70,  
68; Gunstone and Hilaitch, Hilditch and Riley,  
*l.e.*)

Each group of acids is converted into methyl esters\* and the latter are distilled at low pressure (0.2-1 mm<sup>1</sup>) through a fractionating column. Ocker (J.S.C.I. 1937, 66, 199T), has described a suitable type of electrically-heated and packed column. The distillations can be so adjusted that, within very narrow limits, no resulting fraction will contain more than two saturated esters, or more than two homologous groups of unsaturated esters. From the mean molecular weight (saponification equivalent) and the mean unsaturation (iodine value) of each fraction its composition can in general be deduced, and therefrom the component acids present in each group of acids, and ultimately, the proportions of the component fatty acids present in the original fat. (For fuller details of the procedure, *cf.* T. P. Hilaitch, "The Chemical Constitution of Natural Fats," Chapman and Hall, Ltd., 1947, Chapter 3J.)

It should be observed that the above methods are intended to define the fats in terms of their ultimate chemical composition. For rapid evaluation of fats there exist an increasing number of specific determinations (*e.g.*, saponification value, acid value, iodine value, thiocyanogen value, acetyl value, Reichert-Meissl and Polenske values, etc.) which serve to define the analytical characteristics of a fat. These methods, many of which are indispensable in the routine examination of fats in industry, and by the Public Analyst, form the subject of a separate article (OILS (FATTY) AND FATS, TECHNICAL ANALYSES OF, this Vol., p. 52c). It may here be remarked that these methods, valuable as they are for the purposes of control, merely give average values for the molecular size (equivalent), unsaturation, content of steam-volatile acids, or other characteristic of the fat as a whole, and are therefore rarely of use by themselves in elucidating the chemical composition of a fat or of its component fatty acids. For the latter purpose the more complete "ester-fractionation" technique is essential.

**1800.** **Component Glycerides.** — From about 1900 onwards a number of investigators, notably Klimont, Bomer, and Amberger, attempted with a little success to resolve a number of solid natural fats by crystallisation into their individual component glycerides. The general results of their exhaustive studies, although largely negative in character, served to establish the fact long suspected, that simple triglycerides with three radicals of the same fatty acids) are of quite exceptional occurrence in natural fats and that the latter consist, of wholly, of mixed triglycerides.

A quantitative study of natural fat glycerides (J.P.C. 1927, 3106) showed that triglycerides bearing three saturated acid components can be separated from and determined in a fat by digestion in acetone solution with potassium permanganate, when all unsaturated glycerides converted into acidic products of oxidation

and subsequently removed from the irradicated, neutral fully-saturated triglycerides. Application of this procedure to a wide range of solid fats established that, as a general rule, the proportions of fully-saturated glycerides was negligible until the saturated acids present in the fat amounted to more than 60% of the total fatty acids, but that thereafter the proportion of fully-saturated glycerides rapidly increased in such a manner that in the mixed glycerides containing both saturated and unsaturated acids the ratio of saturated to unsaturated acids still remained at about 6:4. Definite exceptions to this generalisation were noted, however, in two groups of fats, (i) animal body-fats containing 10-30% of stearic acid, and (ii) animal milk-fats (*v. infra*).

Subsequently it was found, by study of partially-hydrogenated fats or of the tristearin content of completely hydrogenated fats, that liquid fats, in which oleic and linoleic acids were the chief components, contained proportions of tri-unsaturated glycerides which approached the minimum amount possible, *i.e.*, the unsaturated acids were linked in the form of mixed saturated-unsaturated glycerides with the saturated acids also present in the fat, almost as far as the proportion of the latter permitted.

This earlier quantitative work on glyceride structure led to more precise knowledge of the general tendency towards formation of the minimum possible proportions of mixed triglycerides in natural fats, and also of apparent exceptions, as mentioned above, to this general behaviour in a few groups of fats. Except when the number of component fatty acids was very small (two or three), however, examination of the fats as a whole by the quantitative methods indicated above still failed to give a very complete picture of the component glycerides present. More completely quantitative statements of the component glycerides in a natural fat have been found possible by resorting to the method, used by the earliest investigators, of physical separation of the fat by crystallisation from an appropriate solvent, acetone having been found most useful. Although it is very rarely possible to isolate individual glycerides from a fat by this means, it is comparatively easy to effect separation into groups, usually of different degrees of unsaturation. Thus, glycerides containing three unsaturated acid groups are very freely soluble in cold acetone, those containing two unsaturated and one saturated acid group somewhat less so, whilst mono-unsaturated disaturated glycerides are as a rule but sparingly soluble, and glycerides with three saturated acid groups are usually almost insoluble in cold acetone. Thus, by a few systematic crystallisations of a fat, or of its partly-resolved components, from acetone at concentrations and temperatures which may be suitably varied, it is possible to divide it into four or five fractions, each of which will contain only two of the above groups in large proportions, accompanied by subordinate amounts, at most, of a third group. Determination of the component acids in each fraction, coupled where possible with determination of the fully-saturated glycerides and their component acids,

or of the content of tri-unsaturated glycerides of the  $C_{18}$  acids (oleic, linoleic, etc.) leads in general to a close estimate of the main component glycerides in each fraction, and therefrom to a more or less detailed statement of the composition of the original fat.

With solid or semi-solid fats, crystallisation from acetone down to  $0^\circ$  suffices to give an adequate preliminary resolution of the fats. In the case of liquid fats such, for example, as olive, cottonseed, linseed, or whale oils a similar separation can be made by crystallising from acetone and solid carbon dioxide at progressively lowered temperatures down to  $-40^\circ$  or  $-50^\circ$ . In such instances the only quantitative determination which can be made on the separated fractions is that of their component acids, but very frequently this then suffices to give a good indication of the probable quantitative composition of the mixed glycerides in the original fat.

In fats which contain only three or four major component acids, quantitative study by the procedure outlined in the preceding paragraphs usually affords a definite statement of the chief component glycerides to within 2 or 3 units per cent of the true figures. Where (as, for example, in milk fats or fish oils) the number of component acids is much greater, it is not in general possible to obtain so complete a statement, but the proportions of the chief groups, of triglycerides present can be determined within fairly well-defined limits for each group.

#### COMPONENT GLYCERIDES AND ACIDS IN NATURAL FATS.

It will be evident from what has been said already that, from the point of view of their constitution, the fats may be considered in terms of the actual glycerides present, or merely from the point of view of the nature and proportions of the fatty acids in combination in the whole fats. Whilst the mode of assemblage of fatty acids into the component mixed glycerides of natural fats appears to be governed by the same fundamental principles throughout almost the entire vegetable and animal kingdom, the nature of the particular fatty acids present in a fat is largely governed by biological factors and, indeed, a fairly close connection can be traced between the component acids of many fats and the place of the fat-producing organism, plant or animal, in the scale of evolutionary development (Hilditch and Lovern, *Nature*, 1936, 137, 478).

**General Features of Glyceride Structure in Natural Fats.**—The mode of assemblage of fatty acids in the triglycerides of fats which appears to hold almost universally, throughout nature has often been termed the "rule of even distribution." By even distribution is meant the spreading throughout the triglyceride molecules of the fatty acids in a manner which tends to be as uniform as possible. It should be noted that this is not the same thing as "random distribution," i.e., distribution according to the mathematical theory of probability; if the latter theory applied, indeed, the fats would contain, in most instances higher proportions of the simple triglycerides than are in fact

observed. The operation of the "even distribution" principle is perhaps most readily expressed in the following way. If any one acid forms one-third or more of the component acids of a natural fat, that acid will occur at least once in nearly all the triglyceride molecules; if it forms, for example, from 60-70% of the total acids, very many of the component triglyceride molecules will contain two radicals of the acid in question. On the other hand, if a particular acid is a minor component of a natural fat, amounting to perhaps 10% or less of the total fatty acids, it will of course not be present in all the triglyceride molecules, and will only contribute one acid radical to any triglyceride molecule in which it is present.

It follows from the preceding statement that if a fat contains, say 35% or more of "oleic acid, then this acid will be present in almost all the molecules of the fat glycerides—in other words, as has been demonstrated experimentally," such fats contain only very minor amounts of fully-saturated triglycerides. Similarly, in liquid fats such as olive oil, linseed oil, and other liquid vegetable seed-fats, the acids of which in many cases consist very largely of oleic and linoleic, with minor proportions of palmitic acid, all of the latter is present as monopalmito-unsaturated glycerides, with the result that the proportion of oleo-linoleo-glycerides is the least possible.

This kind of evenly distributed type of natural mixed glycerides has been found to be present in almost all seed fats, solid or liquid, in many fruit-coat fats, in all marine-animal fats so far studied, and in all land-animal body fats in which the saturated acids present are mainly palmitic, with only minor proportions of stearic acid. The experimental evidence is most abundant in the case of solid seed-fats, but the liquid seed-fats which have been so far examined also conform closely with the rule. It is also followed closely in many fruit-coat fats, but in this class a few instances have been observed (especially palm oils) in which there is a tendency for the production of slightly more tripalmitin and triolein than is consistent with complete adherence to "even distribution." Again, those marine animal fats and land-animal body-fats low in stearic acid content which have been submitted to study by the quantitative methods have also been found to conform with the general rule, whilst qualitative studies by Eibner, Suzuki, and others of the crystalline bromo-additive products obtainable from the glycerides of linseed, soya-bean, Whale, cod, herring, and some other oils lend full support to the view that the mixed glycerides of these oils are as heterogeneous a mixture as possible.

Many fats of the above types, containing not more than four major component acids, have now been studied experimentally and their chief component glycerides determined with some degree of certainty. It has been found possible (Hilditch and Meara, *J.S.C.I.* 1942, 61, 117), by a simple calculation based on arithmetical proportioning of one component acid among the rest, and subsequent arrangement of the resulting groups of acids into mixed glycerides, to obtain directly from the proportions of the



<^mponeifoacids in the fat a " calculated " composition for its component glycerides which approximates to that observed by experimental analysis. 'It is notable, that this accordance is not forthcoming unless the *unsaturated acid* (usually *oleic*) present in largest amount is arithmetically proportioned between the saturated and other acids of the fat. It is thus possible by an empirical calculation, based upon the fatty-acid composition of a fat, to predict with some likelihood of reasonable accuracy, when experimental determinations are lacking, the proportions of the chief component glycerides present.

As previously mentioned, there are two broad groups of natural fats which constitute exceptions to (or, more probably, modifications super-imposed on) the "even distribution" principle, namely, animal body-fats, such as tallows, which are relatively rich in stearic acid, and animal milk-fats, which include about 20-26% of saturated acids of lower molecular weight than the oleic acid in their component acids. Broadly speaking, in all instances so far studied, the proportion of stearic acid or of lower saturated acids (as the case may be) seems to be closely connected with that of the oleic acid present, the sum of the latter and either of the former being of an approximately constant order. It has therefore been suggested that either of these forms of land-animal fats may arise by further modification of a preformed mixture of palmitodioleo- and similar glycerides built upon the usual "even distribution" principle. Partial saturation of such oleo-glycerides in the cases of depot fats, and transformation of such oleo-glycerides (by processes involving shortening of the oleic chain) in the case of milk fats would account for the observed composition of the glycerides in these two classes of animal fats.

The component glycerides of a range of pig, sheep, and ox body-fats of varying stearic acid content have been determined experimentally (Hilditch *et al.*, *Biochem. J.* 1938, 32, 1775; 1940, 8f, 971, 1301; 1941, 35, 940). Since, as a result of the presumed bio-hydrogenation process, such fats contain much more fully-saturated triglycerides than fats of similar fatty-acid composition built up purely according to the "even distribution" rule, the empirical calculation described above fails to give results accordant with those observed when it is based on the fatty acids of the whole fat; but, if allowance is made for the palmitic and stearic acids present as palmito- and stearo- (which can be approximately effected from a graph without actual determination of the proportion of fully-saturated glycerides) and the oleic acid of the fat, the proportion between the remaining palmitic and stearic acids, the proportions of myristic, palmitic, and stearic acids, thus calculated agree very closely with the observed ones. This modified form of calculation thus enables the proportions of component glycerides of lards to be approximately computed from the proportions of fatty acids in the whole fats.

In the following table are given the proportions of component acids in the whole fats.

Different Types of Natural Fats.—

The order of different acids combined in a

natural fat varies from four or five in the simplest cases to as many as fifteen or twenty in the most complex fats. It is convenient to group the acids of any fat roughly into two categories, *major* and *minor* component acids. Such a grouping cannot be rigid, but broadly speaking an acid which forms anything from about 10% upwards of the total fatty acids falls into the category of a *major* component acid. *Minor component acids* are those which form less than 10% of the total fatty acids (down to traces of the order of 0.2-0.3% in some instances). The chief utility of roughly dividing fat component acids into these two groups is that it then at once becomes evident that, in a great many instances, fats from organisms which have been grouped together by biologists on morphological or anatomical grounds share the same acids as major components. At the same time, in a number of other groups, one or more of the minor component acids may be markedly characteristic of the particular fats concerned.

As detailed data for the fatty-acid compositions of fats have accumulated over a wide range of material, it has become more and more apparent that natural fats tend to align themselves, by their component acids, in groups according to their biological origin. Moreover, it has become clear that the fats of the simplest and most primitive organisms are usually made up from a very complex mixture of fatty acids whereas, as biological development has proceeded, the chief component acids of the fats of the higher organisms have become fewer in number. In the animal kingdom this change in type is remarkably consistent, and culminates, in the depot fats of the higher land mammals, in fats in which oleic, palmitic, and stearic acids are the only major components. In vegetable seed-fats, as a rule, similar simplicity is found in the two major component acids which, in many families, are confined to oleic, linoleic, and palmitic; but here, in a number of other families, specific fatty acids occur which have been found nowhere else in nature. The systematic consideration of natural fat component acids is therefore best developed in relation to their biological sources, commencing with the fats of minute aquatic flora and fauna, proceeding to those of the larger aquatic organisms and then to those of the two broad groups of land fauna and land flora.

*Component Acids of Fats of Aquatic Origin.* \*\*.

All fats of aquatic origin contain a wide range of combined fatty acids, mainly of the unsaturated series. The latter include acids containing 14, 16, 18, 20, 22 and sometimes 24 carbon atoms in the molecule, and are conveniently denoted as unsaturated C<sub>16</sub>, C<sub>18</sub>, C<sub>20</sub>, etc., acids. These unsaturated acids are present in varying, but major, proportions and in different states of unsaturation. The unsaturation is greater with increasing chain-length: C<sub>18</sub> acids may contain 4, C<sub>20</sub> acids 4 or 5, and C<sub>22</sub> acids 5 or 6 ethenoid bonds (*v. infra*). The only major-component saturated acid is palmitic acid (10-20% of the total acids), with myristic and stearic acid often present as minor components.

Relatively marked differences exist in the proportions of the component acids in fats from fresh-water and from sea-water organisms, respectively. In fats from all fresh-water life, plant or animal, minute or large, the type appears to be much the same, the component acids being relatively rich in unsaturated  $C_{16}$  and  $C_{18}$  acids, with low contents of unsaturated  $C_{20}$  and (especially)  $C_{22}$  acids. The unsaturated  $C_{16}$  acids may form as much as 30%, and the unsaturated  $C_{18}$  acids over 40-45% of the total fatty acids. \*

In the marine world, apart from the fats of marine diatoms and green algae (which, in the few cases reported, belong to the fresh-water type as regards their component acids), there is a marked difference in the proportions of the unsaturated component acids of fats as compared with those from organisms of fresh water. In the fats of red and brown algae and of marine plankton *Crustacea* the unsaturated  $C_{16}$  and  $C_{18}$  acids are less in amount, and the unsaturated  $C_{20}$  and, especially,  $C_{22}$  acids considerably increased as compared with fats of fresh-water organisms. This characteristic difference persists as a general background throughout almost the whole range of marine fish and mammalia, although it is in turn subject to subordinate modifications in fats from different families. Thus, in general, the fats of *Teleostid* fish of which the chief fat-depot is the liver (&?, cod, hake, halibut, and many others) have somewhat less  $C_{20}$  and  $C_{22}$  acids (of somewhat less average unsaturation) than those of *Teleostid* fish of which the fat is mainly deposited in the flesh-tissues (e.g., herring, salmon, etc.); in herring fat nearly half of the total acids may be made up of unsaturated  $C_{20}$  and  $C_{22}$  acids. The salmon is interesting in that its body-fat alters progressively from the "fresh-water" to the "marine" type as the fish develops from a purely fresh-water to a marine animal (Lovern, *ibid.* 1934, 28, 1955, 1961). In *Euzsmofnanch* fish the liver fats may be very similar to *Teleostid* liver-oils, or may contain unsaturated  $C_{20}$  and  $C_{22}$  acids of even higher mean unsaturation; or again; in certain families the liver fats are accompanied by unusually large proportions of the glyceryl ethers (batyl, etc., alcohols, *v. infra*) or by the hydrocarbon squalene, and in such cases it is invariably found that then unsaturation of all the acids in the glycerides is almost wholly monoethenoid, and that up to 10% of a monoethenoid  $C_{34}$  acid is also present.

Whale body-fats are very similar in general fatty-acid composition to many of the *Teleostid* fish oils, although the content of unsaturated  $C_{20}$  and  $C_{22}$  acids tends to be lower. Notably, the fats of Antarctic whales are relatively low in these acids and tend more to resemble in fatty-acid composition that of a freshwater fish. It has also been observed that fish fats from southern oceans (New Zealand) often appear to resemble fresh-water fish-fats rather than the more general type of sea-water fish-fats in their component acids.

Finally, the marine mammalia are marked in certain instances by quite exceptional variations in the composition of their fats. Thus the body and especially the head-cavity oils of the

*PhyseUridx* (sperm whales) consist only of 30-35% of fats (glycerides), the remainder being ester-waxes formed by the union of cetyl (hexadecyl), oleyl (octadecenyl), and other higher aliphatic alcohols with higher fatty acids; the component acids, also, differ in type from the normal, unsaturated  $C_{22}$  acids being almost absent, and the unsaturation of the  $C_{20}$  and  $C_{18}$  acids being nearly all monoethenoid. The body fats of the *Delphinidm* (porpoise, dolphin, white whale) also include a certain proportion of the above-mentioned ester-waxes, and are further notable (especially the fats of the head and jaw cavities) in that they contain large quantities of fcovaleric acid combined in the form of mixed glycerides with the higher fatty acids (Lovern, *ibid.* 1934, 28, 394). The occurrence of tiovaleric acid in natural fats is quite exceptional, not only on account of its low molecular weight but because it is the only known instance of a fat component acid containing an odd number of carbon atoms and a branched carbon-chain. (Other instances, however, are known amongst the wax acids of tuberculosis and other bacilli waxes, e.g., tuberculostearic acid, 10-methylstearic acid,  $C_{19}H_{38}O_2$ , Spielman, *J. Biol. Chem.* 1934, 106; 87).

#### Component Acids of Fats of Land Animals.—

(a) *DiporFats*.—On passing from depot fats of aquatic to those of land animals there is marked simplification in the composition of the mixed fatty acids. Most of the unsaturated acids, except oleic acid, of the former class disappear, still being present in some quantity in fats of amphibians and reptiles, and to a less extent in those of rodents and, perhaps, some birds; but in depot fats of the higher land-animals the proportion of highly unsaturated  $C_{20}$  and  $C_{22}$  acids is reduced to about 3% of the total acids, whilst that of unsaturated  $C_{16}$  (hexadecenoic) acid reaches a minimum at about 3%. In consequence, in the higher land-animals the most abundant component acids are always the monoethenoid oleic and the saturated palmitic acid, the latter being present in much larger quantities than in aquatic animal fats and approaching a more or less constant figure in the region of about 70% in the depot fats of widely different animals such as rat, rabbit, pig, ox, sheep, horse, etc. The final result is that in most of the higher land-animals the major component acids of the depot fats are restricted to oleic, palmitic, and stearic, and, moreover, that about 60-65% of the acids belong to the  $C_{18}$  series, unsaturated or saturated. The major saturated component palmitic acid is usually accompanied by subordinate amounts (1-2%) of myristic acid. In some groups of animals there is marked tendency to produce stearic as well as oleic acid in the depot fats, but in such cases the sum of all the  $C_{18}$  acids present remains approximately constant at between 60 and 65% of the total acids. It is in these fats alone that, in the component glycerides, a departure from the general rule of "even distribution" has been observed (*v. supra*), and that usually large proportions of fully-saturated glycerides (palmitostearins) are found. It seems probable that in these animals a mixture of palmito-oleo glycerides or tri-olein initially synthesized may be partly

reduced by a bio-hydrogenation process, to more saturated products. The progressive changes observed in the contents of palmitic, stearic, and unsaturated

C<sub>4</sub>, C<sub>18</sub>, C<sub>10</sub>, and C<sub>M</sub> acids over a wide range of animal depot fats are illustrated by data taken from the observations of various investigators and collected in Table I.

TABLE I.—COMPONENT ACIDS (WT.%) OF TYPICAL ANIMAL DEPOSIT-FATS.

	Saturated.		Unsaturated.			
	C <sub>M</sub>	C <sub>18</sub>	C <sub>16</sub>	C <sub>18</sub>	C <sub>M</sub>	C <sub>22</sub>
Fifth, fresh-water	13-15	1-2	20-30	40-45	10-12	0-5
Fifth, marine	12-15	1-2	15-18	27-80	20-25	8-12
AV whale	12-15	1-2	15-18	35-40	15-20	5-10
Frog	ai	3	15	52		16
Tortoise	14	4	9	85		7
Lizard	18	7	10	58		5
Domestic fowl	25-28	5-7	6-7	ea. 60	0.5-1	
Boar	24-28	2-0	7-8	ca. 51	0.3-0.5	
Sheep	29	3	10	51		2
Cat	28	14	3	43		3
Lion	29	17	4	43		3
Horse	39	18	2	40		3
Pig	28-29	5-7	1	64-67		1
Sheep	25-29	10-10	2-3	50-65	0.3-1	
Baboon	27-30	13-25	2-3	40-50	0.2-0.5	
	24-28	14-28	1-2	40-50	0.5-1	
	19	6	*	67	0.5	

It will be seen that qualitatively the component acids of animal depot fats are an unusual mixture. By simple mixture and, further, that up to the present no striking departures from the normal have been observed each as are encountered in marine-animal fats (e.g., isovaleric glyceride in *Dipkinidae* fats, etc., *v. supra*) or in vegetable seed fats, where, frequently quite specific and unsaturated higher fatty acids make their appearance (*v. infra*). The oleic acid of animal depot fats is typically accompanied by relatively small proportions of dieneic octadecadienoic acid, C<sub>19</sub>H<sub>31</sub>O<sub>2</sub>, which however in most cases is not associated with the linoleic acid of seed fats, but may probably be a geometrical isomer of the latter, since the unsaturation appears to be located in the 9:10 and 12:13 positions in the carbon chain.

All the above data for animal depot-fats refer to fats as possible to animals which have received their natural diet, herbivorous or carnivorous, and in most cases comparatively low in fatty matter. By far the greater part of the depot fats therefore emanates from fat synthesised from carbohydrate or protein by the animal. It would of course be wrong to think that, in addition, most animals are able to ingest fatty diets, and to assimilate and lay down in their fat depots many of the specific mixed glycerides which may be present in the dietary. Thus it has been notably shown that pigs are unable to utilise as depot fat much of the fatty matter present in vegetable seeds on which they are fed (cf. Ellis *et al.*, *ibid.* 1926, p. 930, 89, 185; 1931, 92, 385).

*Over Fats.*—The liver is probably the main centre of animal-fat metabolism after the consumption of liver lipids is thus of considerable importance. Both glycerides and phosphatides are present in animal livers and in the higher animals component acids of both kinds of liver lipids

differ considerably from those of the corresponding depot or body fat. In the lower land animals (p. 7, amphibians and reptiles) the liver glycerides and phosphatides are very similar to their depot fats (*v. supra*), so that the component acids bear considerable similarity to those of fats of wholly aquatic origin, but have a high content of the unsaturated C<sub>18</sub> and C<sub>19</sub> members, and to some extent of unsaturated C<sub>19</sub> acids, compensated by a content of about 50-65% of unsaturated C<sub>18</sub> acids.

In the pig, ox, and sheep the liver glycerides differ in composition both from the liver phosphatides and the corresponding depot fats, but the two classes of liver lipids share the characteristic of fairly high contents (10-25%) of highly unsaturated C<sub>18</sub> and C<sub>19</sub> acids of the marine-animal oil type. All the liver glycerides of pigs, ox, and sheep have as component acids about 22-30% palmitic, 5-20% stearic, 8-10% hexadecenoic, 40-48% unsaturated C<sub>18</sub> (chiefly oleic), and 8-10% unsaturated C<sub>19</sub> and C<sub>20</sub> acids; the corresponding liver phosphatides have, on the other hand, less (12-20%) palmitic, more (15-30%) stearic, about 6% hexadecenoic, 30-40% unsaturated C<sub>18</sub> (with more dieneic acid than in the liver glycerides) and more (18-25%) unsaturated C<sub>18</sub> and C<sub>19</sub> acids.

Although the animal depot-fats have perhaps relatively little technical interest as fats, they are important as natural sources of vitamins A and D. Some fish-liver oils (especially cod-liver oil) are used medicinally for this purpose, whilst others (halibut-, whale-, soupfin shark-, and perhaps to a slight extent ox- and sheep-liver oils) are unusually high in vitamin A and/or D content and are "worked up" into vitamin concentrates, which serve both for increasing the vitamin potency of medicinal oils and for providing vitamins for addition to margarine, thereby increasing the latter equivalent in value to natural butter.

£c) *Mammalian Milk Fats*.—There is not so wide a range of detailed data here as for the depot fats. The component acids of whale milk-fat are almost quantitatively the same as those of its body fat, and there is reason to think (from the general analytical characteristics, which are the only data available) that the same may hold good for many of the land-animal milk-fats, such as those of the pig, dog, cat, and human milk-fat (*cf.* p. 286). In other groups of land animals, more especially the ruminants, the  $C_{18}$  acids form a lower proportion of the total acids than in the corresponding depot fats, the differences being approximately balanced by the appearance of members of the lower saturated fatty acids ( $C_{10}$ ,  $C_8$ ,  $C_6$  and most notably butyric acid). In the latter type of milk fat the component glycerides exhibit differences in structure from those of all other natural fats exactly similar to those shown by the stearic-rich animal body-fats (*v. supra*).

Of the milk fats in which the lower saturated acids are prominent, those of the cow and buffalo contain most butyric acid and hexanoic acid, the respective proportions amounting to about 4% and 2% (by weight), or 10% and 4% (molar). In sheep and goat milk-fats, the main lower acid present is decanoic (capric), which forms about 8% (wt.) or 10% (molar) of the total acids, and there is also present about 2-3% (wt.) each of butyric, hexanoic, and octanoic acids. In some other milk fats the relative proportions of the four lower saturated acids are much the same as in cow milk-fats, but the amount of each may be only half, or less than half, of that present in cow milk-fats. Milk fats, like that of the cow, which contain relatively large proportions of the lower saturated acids, also contain minor amounts of lower monoethenoid acids with the unsaturation in the same position ( $J^9$ -) as in oleic acid, from  $J^9$ -hexadecenoic,  $C_{16}H_{30}O_2$  (about 3%) to  $J^9$ -decanoic,  $C_{10}H_{18}O_2$  (about 0.2%).

*Component Acids of Vegetable Fats*.—It has been pointed out that the simplest forms of vegetable life (plankton, etc.) produce fats of similar complex and unsaturated nature to the rest of aquatic (animal) organisms, simple or highly developed. From the restricted data available, it seems that a somewhat similar type of fatty-acid mixture, especially rich however in  $J^9$ -hexadecenoic and oleic acids, is met with, in the fats of many bacilli, of yeast and of the spores of cryptogams. As in the animal kingdom, hexadecenoic acid appears to persist throughout all vegetable fats, but in those of the seeds or fruit-coats of the more developed land plants it rarely amounts to more than about 0.5% of the total fatty acids.

The component acids of seed and fruit-coat fats of members of many plant families have been studied in greater or less detail and relatively much more information is at present available in this group than in most of the other realms of vegetable or animal life. As in animals, the most striking feature of the fats of land flora is great simplification in their component fatty-acid mixtures as compared with those of aquatic flora. As in land animals, palmitic and oleic become the most consistently promi-

nent components; but a third acid,  $J^9$ -oleic (oleic) must be added as a component which is so frequent as to be definitely characteristic for fats of land flora. Linoleic and the related, and still more unsaturated, linolenic acid are the typical constituents of the widely distributed class of "drying" seed oils.

*Fruit-coat (pericarp etc.) fats* contain (So far with only one or two possible exceptions) palmitic and oleic acids as the only major components, irrespective of the plant family in which they occur; linoleic acid is also frequently present, but most often only in minor quantities. Fruit-coat fats exhibit a wide range of physical consistency, from the very hard Japan waxes or Chinese vegetable tallow through soft fats such as palm oil to fats, liquid at the ordinary temperature, such as fire oil. Their consistency is determined almost entirely by the relative proportions of palmitic and oleic acids present: thus Japan wax contains nearly 80%, and Chinese vegetable tallow about 65%, of palmitic acid, whilst palm oils contain about 40% each of palmitic and oleic, with up to 10% of linoleic acid, and the liquid olive-oil has amongst its component acids 75-80% of oleic, with only about 10% of palmitic acid about 7% of linoleic acid.

*Seed component acids* show a pronounced tendency to be, at least qualitatively mixtures of the same acids throughout the same botanical family; but some botanical families produce seeds, the fats of which contain one or more acids which are found in no, or at most few, other families. This statement, although subject to occasional exceptions, has been found increasingly, with the collection of more and more data, to be broadly true for the seed fats of all land plants. In *wax seed fats*, it is true, the main component acids are confined to palmitic, oleic, and linoleic in varying proportions; frequently, in these cases, seed fats of the same family exhibit considerable resemblance in the relative proportions of these three acids. Thus seed fats of the *Malvaceae* and *Bombacaceae* are usually high in palmitic acid content (20-25%), and also often contain about 50% of linoleic acid; the component acids of *Ornithoglossaceae* seed-fats are usually made up of about 10-15% of palmitic, 30-60% of oleic, and 60-30% of linoleic acid. Linoleic acid is prominent in many coniferous seed fats, in those of the larger dicotyledonous trees and shrubs, and in shrubs and herbs of *Rosaceae*, *Compositae*, *Labiatae*, *Linaceae* and a number of other familiar and widely distributed plant families.

On the other hand, in many other families (and in this respect land plants differ from all other natural sources of fats) seed fats include as major components a fatty acid (or acids) different from any of the above. In the saturated series, members of all the "even-numbered" acids from decanoic (capric,  $C_{10}$ ) to tetracosanoic, (lignoceric,  $C_{24}$ ) are encountered as major components of one or other type of seed fats. Furthermore, similar cases are encountered in which a wide variety of unsaturated acids, differing in carbon content or in degree of unsaturation from the typical oleic acid of fats, occur specifically in certain groups of seed

fats. WnQst most of the saturated acids referred to are found, at least as minor components, in some kinds of animal fats, the seed-fat unsaturated acids are restricted entirely to the vegetable kingdom and, indeed, almost always to the seed fats of a single family or, sometimes, of only one genus or even species within \*, botanical family. The distribution of these specific acidic components in seed fats is illustrated in Table II.

TABLE II.—OCCURRENCE OF SPECIFIC COMPONENT ACIDS IN SEED FATS.

Saturated acids.	Occurrence in seed fats.
Caprylic, (Octanoic), $C_8H_{16}O_2$ . . . . .	<i>Palmes</i> (minor component).
Capric (Decanoic), $C_{10}H_{20}O_2$ . . . . .	Elm ( <i>Ulmaceae</i> , major component; <i>Paimce</i> , <i>Laumceae</i> , <i>Salvadoraceae</i> (minor component).
Lauric, $C_{12}H_{24}O_2$ . . . . .	<i>Lauraceae</i> , <i>Palmes</i> , <i>Salvadoraceae</i> , <i>Irvingia</i> sp. (Simarubaceae), <i>Virola</i> sp. (Myristicaceae); (major component in varying amounts).
Myristic, $C_{14}H_{28}O_2$ . . . . .	Although present in minor amounts in very many seed fats, accompanying major proportions of palmitic acid, myristic acid is only a major component in <i>Myristicaceae</i> , <i>Salvadoraceae</i> , <i>Irvingia</i> sp. (Simarubaceae), and <i>Palma</i> .-*
Stearic, $C_{18}H_{36}O_2$ . . . . .	Although present in minor amounts in many seed fats, accompanying major proportions of palmitic acid, stearic acid is only found as a major component in seed fats of a few tropical families: <i>Guttiferaceae</i> , <i>Sapotaceae</i> , <i>Sterculiaceae</i> , <i>Dipterocarpaceae</i> .
Arachidic, $C_{20}H_{40}O_2$ . . . . .	Minor, but characteristic component in many <i>Leguminosae</i> seed fats especially <i>Arachis</i> and <i>Soja</i> sp.; trace component in many other seed fats; major component in <i>Pentaclethra</i> sp. (Leguminosae) and <i>Sapindaceae</i> .
Behenic, $C_{22}H_{44}O_2$ . . . . .	Minor, but characteristic component in <i>Arachis</i> sp. (Leguminosae) and in <i>Moringa</i> sp. (Moringaceae).
Lignoceric, $C_{24}H_{48}O_2$ . . . . .	Minor, but characteristic component in <i>Arachis</i> sp., <i>Soja</i> sp., and other leguminous seed fats; trace component in many seed fats; major component in <i>Adenanthera pavonina</i> (Leguminosae).
(*) Monoprenoid :—	
12-Tetradecenoic, $C_{14}H_{26}O_2$ . . . . .	<i>Pycnanthus Tumbo</i> (Myristicaceae). (Major component.)
4'-Octadecenoic (Petroselinic), $C_{18}H_{34}O_2$ . . . . .	Major component in all seed fats of <i>Umbelliferae</i> and <i>Araliaceae</i> ; and of <i>Picrasma quassioides</i> (Simarubaceae).
11-Eicosenoic, $C_{22}H_{42}O_2$ . . . . .	Major component in seed wax of <i>Simmondsia californica</i> .
4'-Docosenoic (isru#e), $C_{22}H_{42}O_2$ . . . . .	Major component in seed fats of <i>Cruciferae</i> , <i>Tropaeolum</i> sp. and <i>Simmondsia californica</i> (seed box).
^"-Hexacosenoic (jklmenic), $C_{26}H_{50}O_2$ . . . . .	Major component in seed fat of <i>Ximenia americana</i> .
4"-Tricosenoic (Lumequic), $C_{30}H_{58}O_2$ . . . . .	Minor component in seed fat of <i>Ximenia americana</i> .
(6) Hydroxy-monoprenoid :—	
12-Hydroxy-4'-octadecenoic (Bicinoleic), $C_{18}H_{34}O_3$ . . . . .	Major component in <i>Ricinus</i> sp. and <i>Agonandra brasiliensis</i> (Olacaceae).
(c) Ethynoid (or ethenoid-ethynoid):	
4'-Octadecenoic (Tariric), $C_{18}H_{34}O_2$ . . . . .	Major component in <i>Picramnia</i> sp. and other sp. (Simarubaceae).
Octadeca-11-en-2-ynoic (Erythogenic), $C_{18}H_{32}O_2$ . . . . .	Major component in <i>Ongokea</i> sp. (Olacaceae).
(W) Cyclic mono- or di-ethenoid .	
Hydnocarpic, $C_{16}H_{30}O_2$ . . . . .	Major components of <i>Hydnocarpus anthelmintica</i> , <i>B. Jcurzii</i> , <i>H. wightiana</i> , <i>Oncoba eclyvata</i> and Rome other species of the family <i>Flacourtiaceae</i> .
asa&s	
Tri- and tetra-ethenoid :	
Non-conjugated:	
4'-Octadecatrienoic (Linolenic), $C_{18}H_{32}O_2$ . . . . .	Major component in <i>Persea</i> sp. (Labiatae), in <i>Linus</i> sp. (Linaceae), <i>Camphis</i> sp. (Moraceae), some <i>Pinus</i> sp. (Conifers), <i>Juglans regia</i> (Juglandaceae) and some other seed fats; minor component in <i>Papaveraceae</i> , some <i>Leguminosae</i> (e.g., <i>Soja hispida</i> ) and other seed fats.
12-Octadecatrienoic, $C_{18}H_{30}O_2$ . . . . .	In <i>Cenothera biennis</i> (Cenotheraceae).
(U) Conjugated :	
13-Octadecatrienoic (Elaeostearic), $C_{18}H_{32}O_2$ . . . . .	Major component in <i>Aleurites tordii</i> , <i>A. montana</i> , <i>A. cordata</i> , and <i>A. trisperma</i> , <i>Riciodendron</i> sp. (Euphorbiaceae); <i>Telfairia occidentalis</i> (Cucurbitaceae); <i>ParinaHum macrophyllum</i> (Rosaceae).
11-Octadecatrienoic (Licanic), $C_{18}H_{32}O_2$ . . . . .	Major component in <i>Licania rigida</i> and <i>ParinaHum sherbroense</i> (Rosaceae).
11-Octadecatetraenoic (Parinaric), $C_{18}H_{32}O_2$ . . . . .	Major component in <i>ParinaHum laurinum</i> and <i>P. glaberrimum</i> (Rosaceae).

Although the occurrence of specific (especially unsaturated) fatty components places many of the families of land flora apart from that of nature as regards their fat types, it is clear that the incidence of these unusual features runs on the whole closely parallel with the groups into which morphologists have placed the parent plants. Throughout the seed fats it is evident that the fatty-acid mixtures present are closely connected with, and dependent upon, differences in biological species. At present this must be regarded as a broad generalisation, susceptible to extension and modification as more data and fats are accumulated.

It should be noted that natural fats must be liquid, or approximately so, at the temperature of the living organism in which they are produced or stored. Consequently the more saturated seed-fats, which are solid at the ordinary temperature of the temperature zones, are not produced in seeds indigenous to the latter climates, but only in sub-tropical or tropical regions where, in fact, they exist practically in the liquid state at the prevailing temperatures. It has frequently been stated that unsaturation tends to be greater in seed fats as the latter are produced in cooler regions (further from the equator). This is a confusion of ideas, for the non-occurrence of relatively saturated fats in cooler climates is simply the consequence of what has been pointed out in the preceding sentences, whilst the converse is not true: many seed fats of high unsaturation occur in plants which grow only in tropical regions, or are capable of growth in both hot and cold climates. In particular, the high degree of unsaturation of species of *Aleurites*, *Hevea*, *Perilla*, *Licania*, and *Parinarium*, to mention only a few tropical or sub-tropical seed fats, is only paralleled elsewhere in nature by the highly unsaturated  $C_{20}$  and  $C_{22}$  acids which are found most abundantly in cold-blooded aquatic-animal organisms.

At the same time, in those plants (*e.g.*, *FFCX*) which thrive in either hot or cold climates, Ivanow (Bull. Applied Botany, Leningrad, 1922-23, 13, No. 2) and others have shown by systematic experiments that when the plant is grown in a cold region higher proportions of the more unsaturated component acids characteristic of the particular seed-fat are produced than from seed produced in a hotter climate.

#### STBUOTUBB OF INDIVIDUAL NATURAL FATTY AOIDS.

The distribution of individual fatty acids throughout the natural fats will be apparent from the discussion of their component acids in the preceding paragraphs. Some notes may usefully be inserted at this point on structural and other features of the individual acids which merit attention.

Of all the natural fatty acids, two may be singled out as most widespread and characteristic: the monoethenoid oleic acid,  $C_{18}H_{34}O_2$ , which is probably present in all natural glyceride mixtures of vegetable or animal origin, and which must be regarded as a major component acid in the great majority of natural fats; and the saturated palmitic acid,  $C_{16}H_{32}O_2$  which

is similarly present, albeit generally in lesser proportions than oleic acid, in practically all known natural fats. In a considerable number of the more unsaturated seed fats palmitic acid may form only from, say, 2-5% of the total acids, but it is extremely rare to find it absent.

Other acids which are almost as ubiquitous as palmitic and oleic acid, but which are most frequently very minor components of natural fats, are the saturated myristic ( $C_{14}H_{28}O_2$ ) and stearic ( $C_{18}H_{36}O_2$ ) acids, and the monoethenoid hexadecenoic or palmitoleic acid,  $C_{16}H_{30}O_2$ . As already indicated, in certain groups of seed fats myristic and stearic acids also appear as specific major components, whilst hexadecenoic acid is similarly a major component of most fats of aquatic origin and fats of the more primitive land vegetable and animal organisms. All the remaining natural fatty acids, saturated and unsaturated, may be considered to be specific types which occur in fats of particular, and frequently quite restricted, groups of vegetable or animal species.

#### Saturated Fatty Acids.

As already indicated, the fatty acids of natural fats are straight-chain members of the aliphatic series, with the general formula  $C_nH_{2n}O_2$  (or  $C_nH_{2n-1}COOH$ ), where  $n$  is an even integer (from 4 to 24). The plant waxes contain still higher members of the same series, from  $C_{26}H_{52}O_2$  to  $C_{86}H_{172}O_{17}$ , usually mixtures of two or three consecutive members of the "even-numbered" series, with one acid predominating. The straight-chain structure of the higher acids from  $C_{18}$  to  $C_{36}$  has been established by X-ray Spectrum analysis (Müller and Shearer, J.C.S. 1923, 123, 2043, 3156; Piper, Malkin, and Austin, *ibid.* 1926, 2310; Ciftci/Piper *et al*, Biochem. J. 1934, 28, 2175; 2189). All the saturated n-aliphatic acids have been prepared synthetically, proceeding from a lower member ( $C_n$ ) to the next higher ( $C_{n+2}$ ), up to n-hexatriacontanoic acid,  $C_{36}H_{72}O_2$  ( $C_{18}$ - $C_{26}$ , Levene and Taylor, J. Biol. Chem. 1924, 59, 905;  $C_{22}$ - $C_{30}$ , Francis *et al*, Proc. Roy. Soc. 1927, A, 158, 691; J.C.S. 1937, 999). More direct syntheses of lauric, myristic, palmitic, and stearic acids were not achieved until 1936, when polyene aldehydes ( $CH_2[CH:CH]_nCHO$  and  $CH_3[CH:CH]_nCHO$ ) were obtained by controlled polymerisation of crotonaldehyde, and were reduced to lauryl and hexadecyl alcohols, which in turn yielded by oxidation lauric and palmitic acids. Condensation of the polyene aldehydes with malonic acid gave further products which, after hydrogenation and decarboxylation, furnished respectively myristic and stearic acids (Kuhn, *ibid.* 1938, 605).

The melting-points of the chief natural solid saturated fats are capric 31.3°, lauric 43.5°, myristic 54.4°, palmitic 62.9°, stearic 69.6°, arachidic 75.4°, behenic 80.0°, and lignoceric 84.2°. The stable (f) forms of simple triglycerides (triglycerin, etc.) melt in general about 2° higher than the corresponding fatty acids.

#### Unsaturated Fatty Acids.

With the exception of the few cyclic ethenoid acids and of hydroxyoleic or ricinoleic acid, all

the naturally occurring unsaturated acids are converted by hydrogenation into the n-aliphatic acid of the same carbon content, thus demonstrating their straight-chain constitution. Oleic and linoleic acids, the most abundant of the natural unsaturated fatty acids, have been shown to occur in nature in the *cis*-form. The corresponding *cis*-geometrical isomers can be produced from them by chemical means, but have not been met with in any natural fat. It is probable, although not yet demonstrated in every instance, that the numerous other ethylenic acids of natural fats also occur predominantly in the less stable or *cis*-modifications. Syntheses of the unsaturated acids of natural fats have to date only been effected in the cases of oleic, linoleic, and chaulmoogric acids.

Oleic Acid, *cis*-9-octadecenoic Acid,



**Naturally:** in view of its abundant occurrence and simple degree of unsaturation much more study has been given to oleic than to any other unsaturated higher fatty acid. Brief reference to its chief reactions will serve to illustrate the methods which are common to the study of oleic acid and its many analogues.

Oleic acid exists in two crystalline forms, melting-points respectively 13° and 16°. It may be purified by crystallising its barium salt from benzene containing 5% of alcohol or, better, its lithium salt from 80% alcohol. Alternatively, the acid itself may be crystallised from acetone at about -40°, admixed, saturated acids being first separated from the solution at -20° (Brown, J. Amer. Chem. Soc. 1937, 59, 6).

On treatment with oxides of nitrogen at room temperature, or with a small proportion of sulphur or selenium at 100° or above, oleic acid is converted into an equilibrium mixture consisting of about 34% of oleic acid and about 66% of the geometrically isomeric *trans*-modification, elaidic acid, m.p. 44°. Esters (including glycerides) of either acid are transformed under these conditions to equilibrium mixtures in which the elaidic form comprises about two-thirds of the total acid present. Analogous behaviour is shown by other naturally occurring unsaturated higher fatty acids. Evidence of various kinds, chemical and physical, leads to the conclusion that oleic and elaidic acids are respectively the *cis*- and *trans*-forms of 9-octadecenoic acid; the physical evidence includes that deduced from X-ray spectra (Vulliamy and Shearer, *loc. cit.*), from infra-red and Raman spectra (McCutcheon, Crawford, and Welsh, *Oil and Soap*, 1941, 183), from studies of unimolecular films on water (Marsden and Rideal, *J.O.S.* 1938, 1163; Harkins and Florence, *Nature*, 1938, 142, 95), and from equilibrium systems formed with mixtures of either acid with stearic acid (Masearelli, *Atti. R. Accad. Sci. Fis. Mat. Napoli*, 1914, [v], 23, ii, 583, etc.).

The position of the ethenoid group in oleic acid was first established in 1894 by Baruch (Ber. 1894, 27, 172) by a somewhat complicated sequence of reactions. More recently it has been confirmed by oxidative scission of oleic acid into acetic and azelaic acids by means either

of ozone or of anhydrous potassium permanganate in acetone. Either or both of the latter methods have been used to establish the structure of most of the other unsaturated acids of natural fats.

Oleic acid was partly synthesised in 1925 by G. M. and R. Robinson (*J.C.S.* 1925, 127, 175), who effected a complete synthesis of 10-ketostearic acid from acetoacetic ester, and also converted the acetylenic stearolic acid into oleic acid, but were unable to convert 10-ketostearic acid into the ethenoid acid; a complete synthesis of the *cis-trans* equilibrium mixture of oleic and elaidic acids was accomplished later by Noller and Bannerot (*J. Amer. Chem. Soc.* 1934, 56, 1563), starting from 9-chlorononyl aldehyde, and by Baudart (*Compt. rend.* 1943, 217, 399), starting from 1-methoxy-6-bromononane and 1-ethoxy-1,2-dibromo-decane. Noller and Girvin (*J. Amer. Chem. Soc.* 1937, 59, 606) subsequently carried out a similar synthesis of linoleic acid, which, however, was accompanied by other isomeric forms of octadecadienoic acids.

Like other long-chain unsaturated acids, oleic and elaidic acids unite additively with bromine to give two different dibromostearic acids, each of which on debromination with zinc reverts to the acid from which it was produced. On mild oxidation, isomeric 9:10-dihydroxystearic acids are produced: oleic acid yields a dihydroxy-acid, m.p. 132°, with aqueous alkaline permanganate, but an isomeric acid, m.p. 95°, when the oxidant is an acyl derivative of hydrogen peroxide (Garro's acid, peracetic or perbenzoic acids; in the latter case an oxidostearic acid is also formed). With elaidic acid the respective oxidising agents lead to production of the opposite acids, *i.e.*, respectively those melting at 95° and 132°. The stereochemical relationships underlying these transformations (in some of which a "Walden inversion" must take place) at present give rise to some conflict of opinion. Either 9:10-dihydroxystearic acid, on further oxidation with dilute alkaline permanganate, is broken down into n-octanoic, oxalic, and suberic acids (instead of n-nonanoic and azelaic acids).

Other *cis*- and *trans*-modifications of the higher monoethenoid fatty acids exhibit exactly similar behaviour to oleic and elaidic acids in their reactions with dilute alkaline permanganate and with acidic derivatives of hydrogen peroxide, yielding similar pairs of racemic forms of optically isomeric dihydroxy-fatty acids.

Other chemical changes characteristic of oleic and related unsaturated fatty acids will be considered later (pp. 47a, 516) when discussing the action of various agents (e.g., atmospheric oxygen, sulphuric acid) on natural fats.

**Natural Monoethenoid Higher Fatty Acids.**—The majority of these require little separate treatment, their occurrence in natural fats having already been indicated in a preceding section. It is useful to tabulate them here according to certain coincidences in their general chemical structure, which are worthy of notice although their precise significance is not apparent.



(a) Monoethenoid acids of the general formula  $RCH:CH[CH_2]_7COOH$ .

Composition.	Acid.	Structural formula.
$C_{10}H_{18}O_2$	J <sup>6</sup> -Décenoic.	$CH_2:CH[CH_2]_7COOH$
$C_{12}H_{22}O_2$	J <sup>9</sup> -Dodecenoic.	$CH_3CH_2CA:CH[CH_2]_7COOH$
$C_{14}H_{26}O_2$	J <sup>9</sup> -Tetradecenoic, myristoleic.	$CH_3[CH_2]_3CH:CH[CH_2]_7COOH$
$C_{16}H_{30}O_2$	J <sup>6</sup> -Hexadecenoic, palmitoleic, zoomaric.	$CM_3[CH_2]_5CH:CH[CH_2]_7COOH$
$C_{18}H_{34}O_2$	J <sup>9</sup> -Octadecenoic, oleic.	$CH_3[CH_2]_7CH:CH[CH_2]_7COOH$
$C_{20}H_{38}O_2$	J <sup>9</sup> -Eicosenoic, gadoleic.	$CH_3[CH_2]_9CH:CH[CH_2]_7COOH$

Of the above adds, all those below  $C_{18}$  are found, as has been observed, in some milk fats. Myristoleic, palmitoleic, and gadoleic acids are characteristic components of fish fats, and palmitoleic acid, it has already been pointed out, occurs in almost all fats, although in very small proportions in most of them (other than those of aquatic origin).

The existence of hexadecenoic acid has been recognised in fish oils for very many years; it has been variously termed palmitoleic and zoomaric acid at different times, and its constitution as J<sup>9</sup>-hexadecenoic acid was not determined until 1925. Similarly, the structure of gadoleic acid, first noticed in cod-liver<sup>^</sup> oil in 1907, was not determined until 1933.

(b) Monoethenoid acids of the general formula  $feH_8[CH_2]_7CH:CH[CH_2]_7COOH$ .

Composition.	Acid.	Structural formula.
$C_{14}H_{26}O_2$	A 5-Tetradecenoic.	$CH_3[CH_2]_7CH:CH[CH_2]_7COOH$
$C_{18}H_{34}O_2$	J <sup>9</sup> -Octadecenoic, oleic.	$CH_3[CH_2]_7CH:CH[CH_2]_7COOH$
$C_{20}H_{38}O_2$	J <sup>11</sup> -Eicosenoic.	$CH_3[CH_2]_7CH:CH[CH_2]_7COOH$
$C_{22}H_{42}O_2$	J <sup>13</sup> -Docosenoic, erucic.	$CH_3[CH_2]_7CH:CH[CH_2]_7COOH$
$C_{24}H_{46}O_2$	J <sup>15</sup> -Tetracosenoic, selacholeic.	$CH_3[CH_2]_7CH:CH[CH_2]_7COOH$
$C_{26}H_{50}O_2$	J <sup>17</sup> -Hexacosenoic, ximenic.	$CH_3[CH_2]_7CH:CH[CH_2]_7COOH$
$C_{30}H_{58}O_2$	J <sup>21</sup> -Tricosenoic, lumequic.	$CH_3[CH_2]_7CH:CH[CH_2]_7COOH$

J<sup>6</sup>-Tetradecenoic acid is present in sperm-head oil, and selacholeic acid in some shark and other *Elasmobranch* fish acids, and also in brain cerebroside (nervonic acid, Klenk). Erucic, ximenic, and lumequic acids are purely seed-fat acids, and a form of J<sup>5</sup>-tetradecenoic acid occurs

in a few Japanese seed-fats of the *Lauraceae*; the  $C_{26}$  and  $C_{30}$  acids have so far only been reported in seed fat of one species of plant. The J<sup>11</sup>-eicosenoic acid has only been encountered in the seed wax of *Simmondsia californica*.

(c) Monoethenoid acids of the general formula  $RCH:CH[CH_2]_9COOH$ .

Composition.	Acid.	Structural formula.
$C_{18}H_{34}O_2$	J <sup>11</sup> -Octadecenoic, vaccenic.	$CH_3[CH_2]_9CH:CH[CH_2]_9COOH$
$C_{22}H_{42}O_2$	A <sup>11</sup> -Docosenoic, cetoleic.	$CH_3[CH_2]_9CH:CH[CH_2]_9COOH$

This group, in which the J<sup>11</sup>-eicosenoic acid in (b) also belongs, is a small one, and all these acids are specific in occurrence. Vaccenic acid is a solid isomer of oleic acid which accompanies the latter in small quantities in the depot and milk fats of cows and sheep; Bertram, who discovered it, attributes to it the structure of a J<sup>11</sup>-acid (Biochem. Z. 1928, 197, 433). Cetoleic acid is the form of monoethenoid  $C_{22}$  acid which occurs in small proportions in most fish and other marine animal fats; its structure was determined by Toyama (J. Soc. Chem. Ind. Japan, 1927, 30, 597).

## (d) Cyclic (cyclopentenyl-) mono- and diethenofatty acids.

A small group of acids, characterised chemi-

Composition.	Acid	Structural formula.
$C_{16}H_{28}O_2$	Hydnocarpic, 11-A <sup>2</sup> -cyclopentenyl-n-undecanoic.	$R[CH_2]_{10}COOH$
$C_{18}H_{32}O_2$	Chaulmoogric, 13-A <sup>2</sup> -cyclopentenyl-n-tridecanoic.	$R[CH_2]_{12}COOH$
$C_{18}H_{30}O_2$	Gorlic, 1S-J <sup>2</sup> -cyclopentenyl-tridecanoic.	$R[CH_2]_{12}COOH$

One carbon atom in the cyclopentenyl group, is asymmetric, and all the natural acids mentioned are strongly dextrorotatory ( $[\alpha]_D +56^\circ$  to  $+68^\circ$ ). The chemical constitution of chaulmoogric and hydnocarpic acids was outlined by Power and Barrowcliff (J.C.S. 1905, 87,

usually by the presence in the fatty acid chain of a cyclopentenyl ring-system

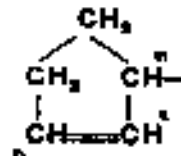

is found in quantity in the seed fats of *Hydnocarpus* and a few other genera of the *Flacourtiaceae*. These fats have specific therapeutic value in the treatment of leprosy and some other diseases. The chief acids of the group are:

884; 1907, 557, 563) and confirmed and amplified by Shriner and Adams (J. Amer. Chem. Soc. 1925, 47, 2727). Racemic chaulmoogric acid was synthesised by condensing n-cyano-undecanoic acid and A<sup>2</sup>-cyclopentene with acetoacetic ester and subsequent



transformation of the condensation product (C<sub>7</sub>H<sub>8</sub>O<sub>2</sub>, C<sub>10</sub>H<sub>16</sub>O<sub>1</sub>, C<sub>11</sub>H<sub>20</sub>O<sub>3</sub>, and C<sub>11</sub>H<sub>14</sub>P<sub>1</sub>) of hydnocarpic acid accompany the latter and chaulmoogetic acid in seeds of some species of *Hydnocarpua* (*ibid.* 1939, 61, 2349). (*Of.* Vol. II, 5216.)

(e) Monoethenoid and n&noethynoid acids mainly of the general formula



Composition.	Acid.	Structural formula.
C <sub>18</sub> H <sub>34</sub> O <sub>2</sub>	J <sub>6</sub> .octadecenoic, petroselinic.	CH <sub>3</sub> [CH <sub>2</sub> ] <sub>10</sub> CH:CH[CH <sub>2</sub> ] <sub>7</sub> COOH
C <sub>18</sub> H <sub>32</sub> O <sub>2</sub>	J <sup>6</sup> .Octadecenoic, tarlic.	CH <sub>3</sub> CH <sub>2</sub> CH=C[CH <sub>2</sub> ] <sub>7</sub> COOH
C <sub>18</sub> H <sub>26</sub> O <sub>2</sub>	Octadeca-J <sup>7</sup> -en-di-ynoic, erythogenic.	CH <sub>2</sub> CH[CH <sub>2</sub> ] <sub>4</sub> C≡C-C[CH <sub>2</sub> ] <sub>7</sub> COOH or CH <sub>2</sub> :CHC≡C-ECH <sub>2</sub> COOH

A few seed-fat acids of the C<sub>18</sub> series contain unsaturation between the 6th and 7th atoms of the carbon chain.\* The most widely distributed is the ethylenic petroselinic acid, a solid (m.p. 30°), isomeric with oleic acid, discovered in 1909 in parsley-seed oil and subsequently found to be characteristic of all Umbelliferous seed fats. It is also present in quantity in ivy seeds and has been observed in one species of the tropical genus *Piper*.

The acetylenic tarlic acid was recognised in 1832 to be a constituent of seed fats from species of *Picramnia*, in one of which (*P. 8&u*) it forms over 90% of the seed-fat component acids (Steger and Van Loon, *Ber. trav. chim.* 1933, 52, 593). It is the acetylenic analogue of petroselinic, and not of oleic acid.

A very rare example of an acid containing both ethylenic and ethynoid bonds has been reported in the fats of two species of *Ongokea*. It is said to contain a terminal ethenoid linkage\* (CH<sub>2</sub>:CH—) and two acetylenic groups which may be located either in the J<sup>6</sup>- or J<sup>7</sup>-positions (Castiue; *Annalen*, 1939, 543, 104).

#### (1) Hydroxy-monoethenoid acid.

Practically the only higher hydroxy-fatty acid to be observed in natural fats (except occasionally for traces of 9:10-dihydroxystearic acids,

Com- position.	Acid.	Structural formula,
C <sub>18</sub> H <sub>32</sub> O <sub>2</sub>	J <sup>9</sup> -12-tetradecadienoic, linoleic.	(i) Diethenoid. CH <sub>3</sub> CH <sub>2</sub> CH:CHCH <sub>2</sub> CH:CH[CH <sub>2</sub> ] <sub>7</sub> COOH
C <sub>18</sub> H <sub>30</sub> O <sub>2</sub>	A 9,12,15-Octadecatrienoic linolenic.	(ii) Triethenoid. CH <sub>3</sub> CH <sub>2</sub> CH:CHCH <sub>2</sub> CH:CHCH <sub>2</sub> CH:CH[CH <sub>2</sub> ] <sub>7</sub> COOH
C <sub>19</sub> H <sub>32</sub> O <sub>2</sub>	J <sup>9</sup> ,ii,i3.octadecatrienoic elaeostearic*.	CH <sub>3</sub> [CH <sub>2</sub> ] <sub>3</sub> CH:CHCH:CHCH:CH[CH <sub>2</sub> ] <sub>7</sub> COOH
C <sub>19</sub> H <sub>28</sub> O <sub>2</sub>	4-Keto-A <sup>9</sup> -MJ-octadecatrienoic, licanic. >*	CH <sub>3</sub> [CH <sub>2</sub> ] <sub>3</sub> CH:CHCH:CHCH:CH[CH <sub>2</sub> ] <sub>4</sub> CO
C <sub>18</sub> H <sub>28</sub> O <sub>2</sub>	J <sup>9</sup> ,i,i3,i s-Octadecatetraenoic, parinaric.	(iii) Tetracthenoid. CH <sub>3</sub> CH <sub>2</sub> CH:CHCH <sub>2</sub> CH:CH[CH <sub>2</sub> ] <sub>7</sub> COOH

The linoleic acid of seed fats is almost certainly in all cases the same modification, namely, 9:12-tetradecadienoic acid. It can be isolated in the pure condition by repeated crystallisation from acetone or distilled petroleum ether (Brown *et al.*, *J. Amer. Chem. Soc.* 1937, 59, 3; 1938, 60, 54; 1941, 63, 1064, 1483; 1943, 65, 259). It yields a crystalline (m.p. 114°) dibromo adduct a liquid tetrabromostearic acid by addition of bromine; on debromination the crystalline

sometimes in the optically active (*d*-) form is *ricinoleic acid*, known for many years to be the chief component acid of castor oil, and also since reported to be a major component acid of a very few other seed fats. It is 12-hydroxy-J<sup>9</sup>-octadecenoic acid,

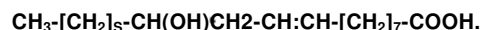

and exists in nature in the *cZ*-form, [α]<sub>D</sub> +6.7°. Its chemical behaviour is entirely analogous in many ways to that of oleic acid; it is the *cis*-isomer (m.p. 5°) to which the *trans*-ricinoleic acid, m.p. 52°, corresponds, and it yields trihydroxystearic acids on mild oxidation. The presence of the alcoholic hydroxyl group causes it to form, on heating, lactide-like intermolecular condensation products (polyricinoleic acids or *eatolidea*), whilst it can be dehydrated to yield a mixture of A<sup>9</sup>- and d<sup>9</sup>-octadecadienoic acids.

#### Natural Polyethenoid Fatty Acids,

(a) Polyethenoid acids of the general formula



These occur almost exclusively in fats of the vegetable kingdom, belonging exclusively to the C<sub>18</sub> series, and include the following:

bromo-adduct reverts to the original acid, whilst the liquid bromo-adduct furnishes a mixture of this and other geometrically isomeric forms. Similarly, linoleic acid furnishes two tetrahydroxystearic acids, m.p. 173° and 161°, on oxidation with alkaline permanganate, and two isomeric acids, m.p. 144° and 136°, on oxidation with an acidic derivative of hydrogen peroxide. The production of these various stereoisomers is considered to be the result of configurational

changes which accompany the addition or removal of halogen, or the oxidation, as the case may be. Seed-fat linoleic acid can be converted into geometrically isomeric forms, the *trans-trans-isomer* having m.p. 29-30° (Kass and Burr, *ibid.* 1939, 61, 1062). In presence of excess of caustic alkali at high temperatures it is isomerised into a mixture of geometrical isomers of the conjugated J<sup>9,11</sup>- and J<sup>10,12</sup>-octadecadienoic acids. Long-chain conjugated diethenoid compounds of this type show an absorption band in the ultra-violet at about 230 m $\mu$ , the intensity of which may be utilised in estimating the amount of these derivatives (Bradley and Richardson, *Ind. Eng. Chem.* 1940, 32, 963; 1942, 34, 237; Mitchell, Kraybill, and Zscheile, *Ind. Eng. Chem. [Anal.]*, 1943, 15, 1; Hilditch, Morton, and Riley, *Analyst*, 1945, 70, 68).

The octadecadienoic acids present in animal-liver, body and milk fats are not identical with seed-fat linoleic acid, although this may also be present in the case of animals fed on herbivorous diets, especially when oil-seeds or oil-cake is included. Mainly, however, they differ in chemical properties from seed-fat linoleic acid and, since the position of the double bonds appears to be the same as in the latter, it is at present supposed that they represent one or more of the other possible geometrical isomers of linoleic acid.

Of the triethenoid acids, *linolenic acid* resembles linoleic acid in that it includes the characteristic grouping



It is exclusively a vegetable (seed fat) product and, as already mentioned, is by no means so widely distributed in seed fats as linoleic acid, although it is a major component of a fairly large number of the more unsaturated ("drying") vegetable fatty oils. Like linoleic acid, it yields a mixture of bromo-addition products (hexabromostearic acids) of which one is crystalline (m.p. 181°). Two hexahydroxystearic acids (m.p. 203° and 173-175°) result in comparatively small yields when linolenic acid is oxidised with alkaline permanganate. By analogy, it is highly probable that the natural acid is *cis-cis-cis* 2,9,12,15-octadecatrienoic acid, and ozonisation having proved that the double-bonds occupy the positions stated. In presence of excess of alkali at high temperatures it is isomerised, first to a mixture of conjugated triethenoid acids, and finally to the triconjugated J<sup>10,12,14</sup>-octadecatrienoic acid (T. Moore, *Biochem. J.* 1939, 33, 1635; Kass and Burr, *J. Amer. Chem. Soc.* 1939, 61, 3292).

It should be recalled that a structurally isomeric linolenic acid, J<sup>9,11,13</sup>-octadecatrienoic acid (thus belonging rather to the "petroselinic" than to the "oleic" series of vegetable unsaturated acids) has been observed (Heiduschka and Luft, *Arch. Pharm.* 1919, 257, 33; Eibner *et al.*, *Chem. Umschau*, 1927, 34, 312) to occur, exceptionally, in the seed fat of the evening primrose, (*Enothera biennis*).

*Elaeostearic*, *licanic*, and *parinaric* acids share in common the presence of a multi-conjugated ethenoid system commencing at the J<sup>9</sup>-position

(the site of the double bond in oleic acid). Of these, *elaeostearic acid* is best known since it forms nearly 90% of the acids of China-wood or tung oil. The presence of three double bonds is shown by the amount of hydrogen taken up during conversion of *elaeostearic acid* to *stearic acid*, and their location by the production of *azelaic* and *n-valeric acids* on ozonisation. The natural conjugated triethenoid acids and their esters are much more readily converted into their more stable geometrically isomeric forms than are oleic or linoleic compounds: exposure to bright light, or presence of a trace of iodine, is sufficient to effect the change. Natural or *"a"*-*elaeostearic acid*, m.p. 49°, is thus transformed into a higher-melting isomeric ("*ξ*"-*elagostearic acid*, m.p. 71°. The products formed by the union of both forms of the acid with atmospheric oxygen on the one hand, and with maleic anhydride (Diels-Alder condensation) on the other, have been studied in considerable detail by Moire J. and co-workers (*J. Oil Col. Chem. Assoc.* 1929, 12/183; *J.S.C.L.* 1931, 50, 337; *J.C.S.* 1932, 2251), who have suggested that the difference between the *a*- and *ξ*-acids lies in configuration (e.g., *cis-cis-trans*- and *trans-cis-cis*-) of the ethenoid groups.

The union of maleic anhydride with two of the three conjugated bonds of *elaeostearic* and similar derivatives has been made the basis of quantitative determination of these conjugated acids or glycerides (Ellis and Jones, *Analyst*, 1936, 61, 812; Kaufmann and Baltes, *Fette u. Seifen*, 1936, 43, 93), whilst they may also be determined by the intensity of the absorption band which they exhibit in the ultra-violet spectrum at about 270 m $\mu$ . (Bradley and Richardson, *op. cit.*).

*Licanic acid*, mainly present in *oiticica* oil from the fruits of *Icacia rigida*, is at present unique amongst natural fatty acids in that it contains a ketonic group. The natural or *"a"*-*licanic acid* melts at 74-75° and is transformed by light in presence of traces of iodine or sulphur to the more stable *"0"*-*licanic acid*, m.p. 99-5°. Its structure was established by Brown and Farmer (*Biochem. J.* 1935, 29, 631; *J.C.S.* 1935, 1632). Its behaviour with maleic anhydride is similar to that of *elaeostearic acid* (Morrell and Davis, *ibid.* 1936, 1481).

*Parinaric acid* is also at present unique as a conjugated tetraethenoid fatty acid. It occurs in quantity in the seed fats of *Parinarium laurinum* (Tsujiimoto, *J. Soc. Chem. Ind. Japan*, 1933, 36, HOB, 673B) and *P. glaberrimum* (Frahm, *Ing. Ned. Indk.*, 1941, 7, 92). The natural or *"a"*-acid melts at 85-88° and the more stable *"0"*-acid at 95-96°. Its structure was determined by Farmer and Sunderland (*J.C.S.* 1935, 759). Its ultra-violet absorption spectrum is very similar to that of decatetraene (Kaufmann *et al.*, *Fette u. Seifen*, 1938, 45, 302).

(6) *Polyethenoid acids of the C<sub>20</sub>, C<sub>M</sub> (C<sub>18</sub> and C<sub>16</sub>) series.*

The acids falling under this heading are chiefly those of fats from aquatic organisms, together with those of related fats of certain land-animal organs and tissues. In the marine animal oils these highly unsaturated acids were first

definite<sup>1</sup> noted by Tsujimoto in 1906 who at that time believed the highly unsaturated acids of sardine oil to be an individual, "clupanctonic acid," of the formula  $C_{18}H_{26}O_2$  but in 1920 noted that its carbon content was greater, and suggested the formula  $C^{18}H^{26}O^2$  for a penta-ethenoid acid. In the meantime it had become recognised that unsaturated acids of both the  $C_{30}$  and  $C_{22}$  series were commonly present in fish oils and that possibly, in each series, acids ranging from tri- to hexa-ethenoid were present.

The present state of our knowledge of this group of acids may be summarised as follows. The highly unsaturated acids in question are relatively unstable and, by the action of either heat or alkali, or both, tend to undergo cyclisation or polymerisation, with consequent loss of unsaturation. It is therefore uncertain whether in all cases the materials prepared for constitutive investigation by processes such as saponification with excess of alkali, fractional distillation at or above  $200^\circ$ , etc., represent to original unsaturated individual? or their transposition products. A great deal of most painstaking work, undertaken notably by Tsujimoto and by Toyama, may be partly open to question on these grounds. But at least the work of these investigators has shown that polyethenoid unsaturation in marine animal oils extends over acids of the  $C_{16}$ ,  $C_{18}$ ,  $C_{20}$ ,  $C_{22}$ ,  $C_{24}$ , and  $C_{26}$  series, and that with increasing molecular-weight the degree of unsaturation and the amount of highly unsaturated acids present in the glycerides both undergo increase. Thus the workers mentioned showed that small proportions of a tri-ethenoid  $C_{16}$  acid and larger amounts of a tetra-ethenoid  $C_{18}$  acid are frequently present, whilst tetra- and penta-ethenoid  $C_{20}$  acids, and hexa-ethenoid  $C_{22}$  acid) often occur abundantly in fish oils. Penta- and hexa-ethenoid  $C_{24}$  and even  $C_{26}$  acids have also been reported occasionally in very small proportions. It is also established that conjugated unsaturation is absent from these acids, and that the characteristic groupings are the  $:CH-CH_2-CH:$  system already familiar in the vegetable polyethenoid acids, together with a considerable proportion of groups of the form  $:CH[CH_2]_nCH:$ , which give rise to succinic acid on oxidative decomposition. The terminal group  $:CH[CH_2]_nCOOH$ , so characteristic of many ethenoid acids in addition to oleic acid, and of vegetable polyethenoid acids, is not present in the highly unsaturated acids at present under discussion, in which the terminal grouping is more usually, but perhaps not always,  $:CH[CH_2]_nCOOH$ .

Distillation, or rather evaporation, of these highly unsaturated acids in the "molecular still" effects their separation without exposure to temperatures exceeding  $120^\circ$ , and at any one passage through the still the time of exposure to this temperature does not exceed two minutes. Consequently rearrangement of these unsaturated systems is avoided by this means, and a study of cod-liver esters by this technique indicated that the numbers of ethenoid linkages in each of the homologous series was 7, 5, 4, 3, 2, 1, and 0 (farmer and Van der Heuvel, J.S.C.I. 1938, 24; J.C.S. 1938, 427). These investigators

also showed that the acid  $C_{22}H_{32}O_2$  is non-conjugated and yields n-behenic acid on oxidation and that, from the products it yields on oxidation with alkaline permanganate, it contains four  $:CJHCH_2CH:$  groups and one  $:CH[CH_2]_2-CH:$  group between the terminal groups  $CH_3CH:$  and  $:CH[CH_2]_2COOH$ . Similar constitutive data, possibly subject to slight uncertainty for the reasons already stated, have been given by Japanese workers for other highly unsaturated fish-oil acids of the composition  $C_{16}H_{26}O_2$ ,  $C^{18}H^{26}O^2$ ,  $C_{20}H_{32}O_2$  and  $C_{22}H_{32}O_2$ ,  $C_{24}H_{36}O_2$ ,  $C_{26}H_{40}O_2$ .

As already mentioned, similar acids, notably arachidonic (eicosatetraenoic),  $C_{20}H_{32}O_2$ , have also been observed in small quantities in the liver and other organic or gland fats, and sometimes in traces in the depot fats of land animals. J. B. Brown (J. Amer. Chem. Soc. 1930, 52, 1135; 1934, 56, 2149; J. Biol. Chem. 1934, 107, 607, 615; 1940, 134, 331; 1942, 142, 671) considers arachidonic acid to be the only higher polyethenoid acid in these land-animal fats, but other workers believe both  $C_{20}$  and  $C_{22}$  acids to be present in most instances. The arachidonic acid of the land-animal fats is apparently  $J^{5,8,11}$ -eicosatetraenoic acid (I. Smedley MacLean *et al.*, Biochem. J. 1940, 34, 1422; Brown *et al.*, J. Biol. Chem. 1942, 142, 679).

#### NATURAL FATS OF TECHNICAL OR POTENTIAL VALUE.

The natural fats have been discussed in the previous pages from the standpoint of their chemical constitution, and it will have become clear that the most logical and systematic classification of these products (in terms of their component acids) is that which follows their place of origin in the biological scale of living matter, vegetable and animal. In describing the chief fats which find or may find industrial applications, it is more convenient to group them somewhat differently, according partly to their physical consistency and (amounting to some extent to the same thing) partly to their utility for specific technical purpose—edible fats, soaps, paints, etc. The various types of natural fats will be considered under the following headings:

#### VEGETABLE FATS.

##### I. SOLID FATS:

- Fruit-coat fats*: Palm oil, Chinese vegetable tallow, Japan wax, etc.
- Seed fats—Nut oil group*: Coconut, palm-kernel, and other *Palmas* fats.
- Seed fats—Lauric and myristic group*: *Lauracem* and *Myristicaea* fats.
- Seed fats—Palmitic-rich fats*: Baobab, pulwara, Java almond, etc.
- Seed fats—Stearic-rich fats*: Cacao butter, Borneo tallow, shea, mowrah fats, etc.
- Seed fats rich in arachidic or lignoceric acid*.
- Seed fats—Chaulmoogra groups*: Chaulmoogra, hydnocarpus, lukrabo oils, etc.

## 11. LIQUID FATS:

(a) *Oleic or "non-drying" type*: **Olivo**, groundnut, almond, rape, mustard, castor oils, etc.

(b) *Linoic or "semi-drying" type*: **Cottonseed**, maize, sunflower seed, sesame oils, etc.

(c) *Linolenic or "drying" type*: **Linseed**, perilla, safflower, hemp-seed, soya-bean oil, etc.

(d) *Conjugated ("drying") type*: **China wood** (tung), oiticica oils, etc.

## LAUD-ANIMAL FATS.

## I. BODY FATS:

(a) *Solid fats*: Lard, beef, and mutton tallow, bone fat, etc.

(b) *Liquid fats*: Goat's-foot oil.

## II. MILK FATS; Cow butter, ghee, etc.

## MARINE-ANIMAL FATS.

I. FISH OILS (BODY OR LIVER): Cod-liver, herring, sardine, menhaden, shark-liver oils, etc.

II. MAMMALIAN OILS: Whale, seal, dolphin, etc. Sperm-whale oils.

The treatment of each group includes tabulated data (i) for fats already in technical use and (ii) for other related fats which may be considered as possible sources of similar fats in addition to those at present available. The

data include the chief analytical characteristics (usually only the average range of saponification and iodine values) and also detailed analyses showing the typical proportions of the characteristic acids of each fat (minor component acids, unless definitely characteristic of a fat, are not always included). The detailed analyses are quoted from communications published during the past twenty years by investigators in various countries, notably Great Britain, the United States, Holland, and Russia. The tables are supplemented by individual description of the more important fats (or by references to other articles in this Dictionary dealing with them) and by indications, where desirable, of other fats which might be available to supplement such

## VEGETABLE FATS. »

## I. SOLID FATS.

## (a) FRUIT-COAT FATS.

The most important solid fruit-coat fat from the industrial standpoint is *palm oil*, from the flesh of the fruit of the West African oil palm *Elseia guineensis*. Two other fats of still higher melting-points, *Chinese vegetable tallow* and *Japan wax*, find restricted applications in some directions. The general composition of all these fats, and of some other fruit-coat fats similar to palm oil, is given in Table III<sup>1</sup>.

TABLE III.—SOLID FRUIT-COAT FATS.

Fat.	Species.	Habitat.	Sap.	Iodine value.	Chloro compound acids.			
					Saturated.		Unsaturated.	
					Palmitic, %.	Stearic, %.	Oleic, %.	Linoleic, %.
Japan wax. Chinese vegetable tallow. Palm oils: Plantation. Native. M " if	<i>Elseia guineensis</i> sp.	Suh-tropics, China, Florida.	220-230 200	8-10 25-38	77 86-69	1 1-3	12 21-25	— —
		Congo, Malaya, Sumatra.	106-210	51-58	40-43	5-4	40-45	6-10
		Nigeria, Cameroon s, Niger, Gold Coast.			37-40 38-40	3-6 2-6	40-47 42-44	6-10 9-10
		Ivory Coast, Sierra Leone, Liberia.			34-55 32-35	6 5-6	48-52 50-52	8-8 7-8
<i>Other fruit-coat fats in comparison to Palm oil.</i>								
Cacao bean shell.	<i>Theobroma cacao</i> .	W. India, W. Africa, etc.	180	40-55	50-55		32-40	7-14
Piquilla. Java almond.	<i>Caryocarpus</i> sp. <i>Canarium</i> , etc.	Brazil, E. Indies, H-Indies.	155 197	48	41	1 3	64 60	3 4

Japan Wax (v. Vol. VII 78a).

Chinese Vegetable Tallow (u. Vol. III, 33a).

Palm Oil, which forms 30-50% of the fleshy part of the fruit of the West African oil-palm, is of much greater technical importance than the preceding fats. It is used in very large quantities in the edible-fat and soap industries, and to a lesser extent in the process of manufacture of tin-plate. Palm oil was originally extracted by primitive methods by the West African natives, the material produced being a fairly hard fat,

often yellowish-brown rather than red in colour, and containing up to 30% or more of free fatty acids; these were usually termed Congo palm oils in the trade. Better qualities of native-produced palm oil, known as Lagos, Bonny, etc., palm oils, contain usually not above 10% of free fatty-acids, are softer in consistency and clearer red in colour. The red colour of palm oil is due to minute proportions of carotene and xanthophyll, and is removed by agitation with activated fuller's earth, or, when the oil is to be used in soap, it may be bleached by gentle

oxidized with dilute chromic acid or moist air. A very large proportion of palm oil is now obtained from plantations of the oil palm cultivated in the Belgian Congo, Nigeria, and other parts of West Africa, and also in Sumatra and Malaya. Under these conditions much more rapid extraction of the oils by pressure or boiling after agitation with water and steam, and the plantation palm-oils are bright red in colour, sweet smelling, with a content of only 3-5% of free fatty-acids.

Plantation oil-palms are almost wholly the offspring of palms of the Lagoa or allied variety, and, as indicated in Table III, their composition is on the whole remarkably constant. Most of the West African native palm oils have a similar mixture of component acids, with about 40% each of palmitic and oleic acids, and up to 10% of linoleic acid; but in a few native palm-oils from the western coastal regions of West Africa the palmitic acid is only about 25-35% whilst the oleic acid approaches 50%. Palm oils contain small proportions (about 5-8%) of tripalmitin and triolein (the latter being probably nonoleodoleins) and to this extent depart slightly from the "rule of average distribution." The chief component glycerides are, however, dioleoyl-dipalmitin and dioleoyl-oleins (which together make up about 75% of the whole fat), with small proportions of dioleoyl-palmitostearin (about 10%) and dioleoyl-stearin (about 3%). Palm oils melt at about 27-30°.

Although future development of the palm-oil industry will probably ensure adequate supplies for its different technical uses, it may be noted that the fruit-coat of the cacao-bean, piquia,

and Java almond (Table III) and the seed fats of the two latter species, and of Pachira, baobab, and phutwara kernels (Table VI) are also rich in palmitic and oleic acids and could probably be utilised as palm-oil substitutes.

(6) SEED FATS: NOT OIL (PALMS) GEOTYP.

Coconut and palm-kernel oils are amongst the most largely used vegetable fats, finding extensive applications in edible oils (margarine) and many high-grade types of soap subordinate, but still important, are the use of the solid pressings ("coconut stearin") of coconut oil in confectionery fats, and the conversion of coconut or palm-kernel oils by high-pressure catalytic reduction into a mixture of higher fatty alcohols corresponding with the original acids present in the fat. The sodium salts of the monosulphates of these alcohols, mixtures find increasing use in the modern detergent industry.

Whilst coconuts and the oil palm (which yields palm-kernel oil) are chiefly cultivated in plantations, which can probably meet the normal trade demands for fats of this type, it should be noted that a number of other kernel fats of the palm family could be utilised equally well for the same purposes, since the component acids of most of the *Palmaceae* seed fats are extraordinarily similar in composition. A few of them, e.g., babassu and murumuru, have already appeared on the market, and a number of others of potential service are listed in Table IV. Factors which must influence their utilisation in practice are, however, the length of time taken by some species to come into bearing, the excessive proportion of hard or tough shell to kernel in some instances, and the proportion of fat in the kernel.

TABLE IV.—SEED FATS OF THE PALM FAMILY.

Fat.	Species.	Localities.	fat content (total %).	Sap. voluc.	Iodine value.	Chief constituents.						
						Saturated.					Oleic, %.	Linoleic, %.
						C <sub>12</sub> , %.	C <sub>14</sub> , %.	C <sub>16</sub> , %.	C <sub>18</sub> , %.	S <sup>*</sup> , %.		
Coconut.	<i>Oncas nuda</i> .	Tropical countries.	60-65	250-260	8-10	8	7	43	18	S	6	1
Palm kernel.	<i>Elaeis laevis</i> .	W. Africa, etc.	45-50	243-250	15-18	3	7	47	16	0	18	1
Babassu.	<i>Attalea funifera</i> .	Brazil, W. Indies, etc.	63-70	247-253	12-16	6	4	46	20	7	18*	—
Cohutte.	<i>A. cohune</i> .	Honduras.	65-70	252-250	11-14	7	7	46	16	a	10	1
Uruj.	<i>A. extensa</i> .	Central and S. America.	70-73	250-250	10-16	0	8	46	0	8	13	2
Coury.	<i>Antrocaryum</i> .	Brazil.	36-42	237-242	11-12	1	2	43	37	b	11	1
Muni.	<i>mumum</i> .											
Tucuaio.	<i>A. tucuma</i> .	Brazil, W. Indies.	35-40	240-245	10-14	1	4	49	22	0	13	2
Grugru.	<i>A. crocomi</i> .	Brazil, W. Indies.	50-60	245-255	10-20	8	6	45	13	8	16	1
Bete) nut.	<i>sclerosearpa</i> . <i>Areca catechu</i> .	Pacific Is.	?	230-235	20-24	—	1	45	22	3	20	—

All the fats in Table IV contain as their chief component lauric acid (45-50%), the next most abundant being myristic acid (usually about 10% with minor proportions of octanoic, decanoic, palmitic, and oleic acids; stearic and linoleic acids do not exceed more than 1 or 2% in any instance. Certain subordinate differences in composition are noticeable. In coconut and some other fats the oleic acid content is 10% or less, but in another group (which includes palm-kernel oil) this rises to from 16 to 20%.

that term "oleic" "oleo" indicate mono-unsaturated glycerides with oleic acid (or glycerides).

Again, whilst coconut and a few other fats include about 7% each of octadecanoic and decanoic acids in their component acids/in the seed fats of other species there is sometimes less of one or both of these acids (in those of *Astrocaryum* species they only amount to 1-4%). The component glycerides of the nut oils conform closely to the "rule of even distribution" and are consequently a complex mixture. The relatively small proportion of unsaturated acids is present in the form of about 4 parts of mono-unsaturated to 1 part of di-unsaturated glycerides, and the bulk of the fats (80-85% in coconut, and 63-66% in palm-kernel oil) consists of fully saturated glycerides containing three saturated acyl groups. One lauric acyl group is probably present in all, or very nearly all, the triglyceride molecules, and a considerable proportion of the latter may contain two lauric groups, but trilaurin has not been detected in either coconut or palm-kernel oils. Myristic acid probably occurs once, and occasionally twice, in many of the triglyceride molecules, but the rest of the component acids will as a rule contribute only one acyl group to some (and none to others) of the triglyceride molecules. Thus there will be many individual glycerides present, practically all of which will contain one, and some two, lauric acyl groups. The most abundant component (and the only one which has been definitely isolated by fractional crystallisation from coconut and palm-kernel oils) is dilauromyristin; others doubtless present are laurodimyristin, lauromyristo-olein, caprylolauropalmitin; etc.

Most fats of this group become liquid at about 25-28°, but murumuru fat melts somewhat higher (over 30°).

Coconut Oil (v. Vol. III, 238a, 243a).

Palm-kernel Oil (v. Vol. III, 243a, c).

It is difficult to give close figures for the world production of these oils, but immediately prior to 1939 the annual production of coconut oil was of the order of 500,000-600,000 tons, and of palm-kernel oil about 250,000-270,000 tons.

**Possible Substitutes for Coconut and Palm-kernel Oils.**—It will be seen from Table IV that a number of other kernel fats of the *Palmse* could be equally well utilised in place of coconut and palm-kernel oils. In view of the extent to which the latter fats are now produced from plantation palms it is perhaps doubtful whether the demand for fats of this type will not be wholly met in future from these two sources. Nevertheless other fats of the group have appeared in commerce from time to time, although the quantities are so far very small compared with the consumption of coconut and palm-kernel oils. *Babassu-kernel fat* (v. Vol. III, 243d) (from *Attaka funifera*) is the most prominent of these, and has been imported into Europe as well as the United States; it grows both in parts of French West Africa and in Brazil and other parts of South and Central America. The kernels of two other species of *Attalea*, *ouricoury nuts*, and *cohune nuts* (v. Vol. III, 243(2)), have also attracted some interest; the former, from Central and South America, has received some notice in the United States, whilst the cohune palm is abun-

dant in the wild state in British Honduras but difficulties of collection and the large proportion of nut to kernel are probable obstacles to its wider utilisation. The kernel fat of the murumuru palm (v. Vol. III, 244a) (*Astrocaryum murumuru*) of Brazil has also come on the market in comparatively small lots. Murumuru and cohune fats incise to the coconut type in composition, and babassu and ouricoury fats, rather to the palm-kernel type. So far as is known, the parent palms have not been cultivated, the fruits being gathered from native forest trees; it would appear that any serious competition with coconut or palm-kernel oils will demand systematic cultivation on lines similar to those now employed in the coconut oil-palm plantations.

#### (c) SEED FATS RICH IN LAURIC AND MYRISTIC ACIDS.

In addition to the *PaJ.maef&erne* fats, typically rich in lauric and (to a less degree) myristic acids, the seeds of certain other tropical plant families contain fats rich in either or both of these acids. Although up to the present none of these fats have found any special industrial application, reference should be made to a few of them because (a) fats which are very rich in one of these acids may come to have some importance when lauric (or myristic) acid is demanded technically, either for itself or for reduction to the corresponding long-chain alcohol; (6) some of the fats may be of potential interest to the confectionery trade. The more interesting members of this group are therefore given in Table JI

Of the fats in Table V, those of the *Lauracex* and *Myristicacese* are extremely rich in lauric or myristic acids, respectively, and could serve as technical sources of these acids; whilst dika (v. Vol. IV, 3d) and khakan fats (v. Vol. III, 2446) might possibly be of interest in confectionery by reason of the comparatively simple mixture of mixed glycerides (lauromyristins) of which they consist. The presence of high proportions of glycerides such as trilaurin, trimyristin, or lauromyristins causes most fats of this group to be hard and brittle in texture although their melting points are not above 40-45°. Coloured resinous compounds accompany several of the *Lauracese* and *Myristicacese* fats in the seed endosperms.

#### (d) SEED FATS RICH IN PALMITIC ACID.

The seeds of a number of tropical plants contain white or cream-coloured solid fats somewhat resembling palm oil in composition and physical properties. They may be regarded as potential substitutes for the latter, although it would appear that the production of palm oil is sufficient to meet the normal demands for fat of this type. The general characteristics of some seed fats of this nature are given in Table VI.

\*

#### (e) SEED FATS RICH IN STEARIC ACID.

These are found in the seeds of a few tropical families (notably *Sapotaceae*, *Quittifere*, and *Dipterocarpaceae*) and fall into two groups:

(i) *Fats containing not more than 40% of oleic acid, and consequently consisting largely of*



TABLE V.—SEED FATS RICH IN LAURIC AND/OR MYRISTIC ACIDS.

Fat	Species.	Habitat.	Fat content (seed), %	Sap. value.	Iodine value.	Chief component acids.			
						Lauric, %	Myristic, %	Palmitic, %	Oleic, %
<b>Family Lauraceae.</b>									
Cinnamon.	<i>Actinodaphne</i> sp.	India.	70-75	280-285	8-15	90-95	—	—	10-5
	<i>Cinnamomum camphora</i> .	"	40	280-285	4-5	95	—	—	5
Ever bush.	<i>Lindera benzoin</i> .	N. America.	4S	284-285	1-2	95	—	—	5
Tangkallak.	<i>Lepidadenia ivightiana</i> .	E. Indies.	50	70	2	87	—	—	13
	<i>Litsea</i> sp.	India, E. Asia.	45-55	245-270	5-40	70-95	—	—	30-5
	<i>Neolitsea involu-crata</i> .	Ceylon.	CG	255	22	85	4	—	4
<b>Family Myristicaceae.</b>									
Nutmeg.	<i>Myristic* frag-rans.</i>	E. Indies.	40-45	180	30	2	77*	10	10
	<i>Ocotea gabani</i> .	W. Africa.	69	238	2	—	98	—	2
Kombo.	<i>Virolaswija</i> .	Sierra Leone.	60	225	67	5	62	4	6*
Virol**	<i>Virolaswija</i> .	S. America.	70	230	14	15	73	5	6
Otobo.	<i>V. fatoba</i> .	"	65	200	14	21	73	1	5
Ifuhuba.	<i>V. bicuhya</i> .	"	65	220	10-15	5	73	11	11
Also 23% tetradecenoic acid.									
<b>Family Simarubaeae.</b>									
	<i>Irvingia barteri</i> .	Nigeria.	55-65	240	10-15	39	50	—	11
	<i>I. gabonensis</i> .	"	55-65	240-250	3-5	59	33	—	2
	<i>I. tiveri</i> .	Indo-China.	55-60	230	6	39	56	—	5
<b>Family Salvadoraceae.</b>									
Khakan.	<i>Salvadora oleoides</i> .	India, E. Asia.	40	230-230	6-6	20	55	18	6

TABLE \*VI.—SEED FATS RICH IN PALMITIC ACID.

Fat.	Species.	Habitat.	Fat content (seed), %	M.P. °C.	Sap. value.	Iodine value.	Chief component acids.		
							Palmitic, %	Stearic, %	Oleic, %
Baobab.	<i>Adamonia</i> sp.	India, Madagasc.	40-60	25-35	190	55-65	37	2	42
Pili nut.	<i>Canarium pachy-Vhyllum</i> .	E. Indies.	70	30	190-200	56-60	38	2	60
giqufa.	<i>Caryocarpilosum</i> .	E. Indies, Brazil.	55-60	30-35	195-200	50	48	1	46
gachira.	<i>Pachira aquatica</i> .	Congo.	40	30	200-205	55-60	46	—	43
hulwara.	<i>Madhuca (Bassia) bvtyrqfea</i> .	India.	60-65	40-45	190-200	38-40	55	4	36

okodigaturated glycerides.—These possess comparatively low melting-points (30-35°) and also a brittle texture, so that they are specially useful as confectionery (chocolate) fats. Cacao butter is the most valued fat in this class, but several of the others quoted in Table VI are also of use, as substitutes for cacao butter. They contain more than 40% of oleic acid, and with increasing proportions of oleic acid the melting-point falls and the texture of the fats at room temperature becomes softer and more plastic. Some of the fats in this sub-group are rich in stearic acid, whilst the rich in oleic acid are pressed to acquire the rigid consistency desirable in confectionery.

All of the fats in both groups contain

substantially only stearic and oleic acids and could therefore serve if required as technical sources of stearic acid or tristearin.

Cacao Butter (v. Vol. II, 183(2)). The brittleness coupled with low melting-point, which is the characteristic physical property of cacao butter, is due to its specific composition. With somewhat less than 40% of oleic acid in the fat, its glycerides consist of about 75% of mono-oleo-disaturated and nearly 25% of dioleo-glycerides; the saturated acids are a mixture of palmitic and stearic acids, and about 55% of the fat consists of oleopalmitostearin, with about 20% of the somewhat higher-melting oleodistearin. This combination of properties is particularly fortunate since, of course, it is also unnecessary to remove the characteristic flavour of the fat by refining when it is to be used for chocolates.

TABLE VII.—SEED FATS RICH IN STEARIC ACID (&gt;40% OLEIC ACID).

Fat.	Species.	Habitat.	Fat content	M. p., °C.	Sap. value.	Iodine value.	Chief component acids.		
							Palmi- tic, %.	Stearic, %.	Oleic, %.
Cacao butter. Borneo tal- low.	<i>Theobroma cacao</i> . <i>Shorea aptera</i> .	Tropics. E. Indies.	50-55 45-50	33-35 28-37	192-195 192-196	35-42 34-37	24 20	35 43	37'
Kokuin. Bouandja, Mkanyi.	<i>Garcinia indica</i> . <i>Allanblackia</i> sp.	E. and W. Africa, Nigeria.	30 67-70	40-45 40-45	187-191 187-192	40-45 38-44	2 0-2	56 52-50	40 37-40
Njatuo	<i>Palaquium ob- longifolium</i> .	E. Indies.	50-55	38-40	190-200	35-40	—	54	40
Surin.	<i>Payena landjolia</i> .	"	50-55	45-50	185-190	45	—	58	42 <sub>m</sub>

Other fats have been sought as supplements for cacao butter, including the "stearins" obtained by pressing from coconut and palm-kernel oils, and also shea butter (*v. infra*) or its pressed "stearin." Further possible substitutes for cacao butter are dika-nut fat (*v. supra*) and the *Garcinia* and *Allanblackia* fats which are referred to below. The only one which has been used at all extensively so far in place of cacao butter is, however, Borneo tallow.

Borneo Tallow (*v. Vol. II, 31c*).

Another group of fats, including those of the nuts of *Allanblackia* species of Western and East Africa, kokum butter (*Oarcinia indica*) from India, and the East Indian njatuo and surin fats, are made up of about 40% oleic acid with the remainder almost wholly stearic acid, so that they consist of 75-80% of oleodistearin with 25-20% of stearodiolein. Such fats are

ideal for confectionery from the point of view of texture, but the preponderance of oleodistearin, which melts at 4-45°C., renders the melting-point somewhat high for confectionery purposes. Other fats of related *Apocyn* or genera, which contain more oleic and less stearic acid (*c/l.* below), might by pressing yield "stearins" of more appropriate melting-point and suitable texture; these include\* those of other *Oarcinia* species (gamboge and *urgibutteu*),\* kanya and shea fats, Malabar tallow, and some others.

(*ij Fata containing more than 40% of oleic acid.*—A number of other fats, which, in addition to oleic acid, contain little but stearic acid as the remaining component, are listed in Table VIII. Of these shea, mowrah, and illipe" butter, and perhaps Baku fat have received some technical attention from time to time.

TABLE VIII.—SEED FATS RICH IN STEARIC ACID (&gt;40% OLEIC ACID).

Fat.	Species.	Habitat.	Fat content (seed), %	M. p., °C.	Sap. value.	Iodine value.	Chief component acids.		
							Palmi- tic, %.	Stearic, %.	Oleic, %.
Shea.	<i>Buiyrodpermum parkii</i> .	W. Africa.	50	25-32	186-196	56-62	6-8	36-41	49-50
Mowrah.	<i>Madhuca (Bassia) latifolia</i> .	India.	50-55	25-30	107-194	58-63	16-24	25-19	45-3
Illipe* butter.	<i>M. (E.) longifolia</i> .	India, Ceylon.	55-57	25-29	186-200	50-64	28	14	49
Baku, Durnbrl. Gamboge butter.	<i>Mimusops (Dumoria) sp.</i> <i>Garcinia campigia</i> .	W. Africa. India.	45-50 30	30-35 35	1(18-192) 198	50-60 70	4 —	36 30	59 70
Gurgi nut. Kanya.	<i>G. morella</i> . <i>Pentadesma butyracea</i> .	W? Africa.	30 55-60	33 30-40	195 186-197	55 (35-50)	1-7 5	46-42 46	49-44 48
Malabar tal- low.	<i>Vateria indica</i> .	India.	50	36-42	189-192	40-50	10	39	48
Java almond.	<i>Cananum</i> sp.	E. Indies.	32	32-34	186-190	53	M-30	40-10	44-40

Shea Fat (*v. Vols. I. 6546; II, 168i; III, 886*).

Mowrah Fat (*v. Vol. II, 653a*).

Baku Fat, from the nuts of various species of *Mimusops* which are abundant in West and Central African forests, is a product of similar type to shea fat and should be equal to the latter in technical value.

The other fats quoted in Table VIII are probably only a selection of those of similar nature and properties which are found in specific

tropical nuts and seeds, but at present they await development and introduction into the fat industries.

(*) SEED FATS RICH IN ARACHIDIC OR LIGNOCERIC ACIDS.*

A few solid seed fats from certain species belonging to the families *Leguminosae* (*Mimosoidae*), and *Sapindaceae* are unusually rich in arachidic or lignoceric acids. These fats have hitherto found no special technical application,



and are mentioned here solely as convenient sources of natural arachidic (n eicosanoic) and hgnocenc (n tetracosanoic) acids.

The seed fats of the following trees and shrubs contain arachidic acid in proportions varying from 20-50% of the mixed fatty acids (stearic acid is usually also present in these fats) *Pentaolethra* species (West Africa and Brazil), *Neyhebum* species (rambutan and pulasan tallows, East Indies), *Sapindus trifoliatus* (soap nut, India), and *Schleichera tnjuga* (kusum or macassar, India).

The nut of the coral tree of India, *Adenanthera pavonina*, contains fat in which 25% of the acids consist of hgnocenc acid.

(g) SEED FATS CHAULMOOGRA (JROUF to Voi, II, 5216).

These fats, which are almost solid at the ordinary temperature of temperate climates, are not produced in quantities comparable with many of the more familiar vegetable oils and

fatty oil. They are specifically important, however, owing to their therapeutic value in the treatment of certain diseases, notably leprosy, and they are interesting because they contain acids (chaulmoogric, hydnoicarpic, and gorhic) which contain a cyclopentenoid ring system at the end of the chain of carbon atoms, and thus possess the general formula

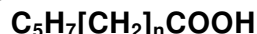

(c. p 126) The fats of this group all occur in the seeds of species belonging to the family *Flacourtiaceae*, but it should be noted that some other seed fats of this family do not contain glycerides of these cyclic acids and are ordinary fatty oils of a "semi drying" or "drying" nature in which the chief acidic components are oleic, linoleic, and linolenic acids. The fats of the chaulmoogra group are characterised by fairly high optical rotatory power (dextro rotatory) The properties of the chief members are outlined in Table IX

TABLE IX — SATURATED FATS OF THE CHAULMOOGRA GROUP

General Characteristics							
Fat	Species	Habitat	Fat content (seed), %	M <sub>D</sub> P	[α]	Sap value	Iodine value
8E5BV Hyfoocarpus, GorJi <sup>ca</sup> jtapocainha	<i>Arak togenos kurin</i>	E Indies	55	33-39	+ 44 to 51°	197-208	97-105
	<i>Hydnocarpus anthelmintica</i>	Siam, E Indies	18-20	23-20	+ 51 to 54°	201-212	83-91
	<i>H wightiana</i>	E Indies	41	28-32	+ 54 to 64°	197-208	93-103
	<i>Ontoba echindta</i> <i>Qarpotroche</i> Cav&y <i>Iien8i8</i>	Central Africa Brazil	46-47 65-70	35-45 21-23	+ 56° + 53°	190-192 184	98 70
(n) Component Acids (Cole and Cardoso, J Amer Chem Soc 1938, 60, 614, 617 1939, 61, 2351, 3442)							
Fat	Palmitic C <sub>16</sub> H <sub>32</sub> O <sub>2</sub>	Oleic C <sub>18</sub> H <sub>34</sub> O <sub>2</sub>	Hydnocarpic C <sub>18</sub> H <sub>28</sub> O <sub>2</sub>	Chaulmoogric C <sub>18</sub> H <sub>26</sub> O <sub>2</sub>	Oleic, C <sub>18</sub> H <sub>30</sub> O <sub>2</sub>		
8E5BV	40	14.6	34.9	22.5	22.6		
Hyfoocarpus	75	12.3	67.8	87	14		
GorJi <sup>ca</sup>	18	65	48.7	27.0	12.2		
jtapocainha	78	23	ml	74.9	14.7		
apocainha	66	63	45.0	24.4	10.4		

11 LIQUID FATS (FATTY OILS)

(a) OLEIO QB "NON DRYING" TYPE.  
The number of important vegetable fatty acids is greater than that of the fatty acids accompanied by varying and subordinate amounts of stearic acid and of saturated acids. (Often almost wholly palmitic acid) relatively stable to atmospheric oxidation and are therefore, termed "dry" oils, have a variety of uses and are divided into several classes

Walnut oil, important as a salad and edible oil, for soaps, and as an oil used in certain textile industries.

- (ii) Almond oil and some closely related oils, used mainly in cooking and pharmacy,
- (iii) Groundnut oil, used very largely in margarine and some cooking fats,

hydrogenated groundnut oils are also much used in pastry and similar fats;

- (IV) The rape and mustard oils, which contain erucic acid as well as oleic acid and have a number of specific applications,
- (v) Castor oil, which possesses special properties owing to its high content of ricinoleic (hydroxyoleic) glycerides

In discussing the vegetable fats in each of these groups, references are given to other fats of similar composition which might be considered as possible supplements or substitutes in each class

(1) Olive Oil (v this Vol, p 91a)

Most of the olive oils of commerce, from the Mediterranean littoral or California, have as component acids 77-84% of oleic acid, with about 10-12% of saturated acids (mainly

pilmitic) and 7-8% of Knoleic acid; a few oils, chiefly from certain Mediterranean islands, have been observed to contain less oleic acid (65-70%) with about 15-20% of palmitic and 10-15% of Knoleic acids. Apart from occasional and very small proportions of tripalmitin and oleopalmitin the olive-oil glycerides are constituted on "evenly-distributed" lines and the amount of triolein tends towards the minimum possible. The usual types of olive oil only contain 35-40% of triolein, and the varieties with lower oleic acid content practically none. The rest of the oil consists largely of linoleodiolein and pahnitodiolein.

Genuine olive oils contain about 0.8-1% of unsaponifiable matter, the iodine value of which

(200-220) is much higher than that\* of the unsaponifiable matter in any other vegetable fat.

There are a number of other seed fatty-oils which, so far as general composition goes, resemble olive oil more or less closely and ought therefore, to be able to replace it in at all events some of its applications. Particulars of some of these fats, in addition to those for olive oils, are given in Table X.

Of the fatty oils in Table X, avocado pear and patua palm oils, like olive oil, are fruit-flesh fats; the rest are seed fats. Michelia, loofah, and kadam oils resemble olive oil in their oleic acid content, but are more akin to groundnut oil and cottonseed oil (*v. infra*) in their fairly high contents of saturated acids.

TABLE X.—OLEIC ("NON-DRYING") FATTY OILS: OLIVE-OIL TYPE.

Fat.	Species.	Habitat.	Fat content,	Sap. value.	Iodine value.	Chief component acids.		
						Satur.	Oleic	Linoleic
Olive.	<i>Olea Europaea.</i>	Mediterranean countries, etc.	30-60.	189-195	80-85	9-12	77-84	4-9
Avocado pear.	<i>Persea gratissima.</i>	Sub-tropics.	10	180-186	80-90	5-20	85-70	11
Patua palm.	<i>(Enocarpus patua.</i>	Brazil, etc.	10-20	190-200	90-95	8	80	4
Teacod.	<i>Tilea sinensis.</i>	India, China, etc.	25-40	188-195	88-94	15	80	7-9
Michelia.	<i>Michelia champaca.</i>	£. Indies.	30	196-199	65-70	8-9	83-84	—
Loofah.	<i>Luffa ap.</i>	Africa, E. Indies.	40	188-196	90-100	30	70	—
Kadam.	<i>Tricosanthes kadam.</i>	Tropics.	05-70	195-197	70-80	20	80,	—
						2b	80,	—

(ii) Almond Oil and Some Related Oils. (*v. Vol. I, 259c, 260a*).

Several other cultivated species of *Prunus* and related genera of the same family yield seed fats closely similar to almond oil, and are noted

in Table XI. The chief component acids, are oleic (usually 65-75%), with varying proportions of linoleic (20-40%) and very small amounts (5-10%) of saturated (chiefly palmitic) acid.

TABLE XI.—OLEIC ("NON-DRYING") FATTY OILS: ALMOND-OIL TYPE.

Kernel fat.	Species.	Habitat.	Fat content, %.	Sap. value.	Iodine value.	Chief component acids.		
						Saturated, %.	Oleic, %.	Linoleic, %.
Almond ( <i>v. Vol. I, 259c, 260a</i> ).	<i>Prunus amygdalus.</i>	Temperate and sub-tropics.	40-55	188-192	93-100	3-5	77	7-20
Apricot ( <i>v. Vol. I, 253a</i> ).	<i>P. armeniaca.</i>	Temperate and sub-tropics.	40-45	188-198	96-112	4	64	32
Peach.	<i>P. persica.</i>	Temperate and sub-tropics.	32-35	189-196	92-110			
Plum.	<i>P. domestica</i>	Temperate.	40-42	188-198	91-104	6	72	22
Cherry ( <i>v. Vol. III, 25c</i> ).	<i>P. cerasus.</i>		30-40	190-198	110-115			
Cherry laurel ( <i>v. Vol. III, 26a</i> ).	<i>P. laurocerasus.</i>	Sub-tropics.	25-30	100-195		14	73	13
Portuguese laurel.	<i>P. lusitanica.</i>	it	25-30	190-195	115	10	58	32
Quince.	<i>Cydonia vulgaris.</i>	Temperate.	15	180-188	113-120	9	45	42

(iii) Groundnut (Arachis), Peanut, Earthnut Oil (*v. Vol. I, 454c*).

The component acids of groundnut oil include 55-65% of oleic acid with about 17-26% of linoleic acid; the proportion of linoleic acid appears to depend on the source of the nuts, some of the West African oils having the lower contents of 20% or less. Of the 15-20% of saturated acids, palmitic usually amounts to 6-8% and stearic 3-5%; the remaining 6-7%

consists of arachidic, behenic, and lignoceric acids, which are characteristic minor components of this oil. The glycerides are of the "evenly-distributed" type, and in an average groundnut oil are made up of about 25% of linoleodiolein, 20% of triolein, and 55% of glycerides containing two unsaturated and one saturated fatty acid.

Hydrogenated groundnut oils, of iodine value from about 50-70, find application in the manu-

facture of "shortenings" or vegetable cooking fats employed as substitutes for lard in pastry, biscuits, etc. Both groundnut oil itself and lightly hydrogenated groundnut oil are also used in the fried-fish industry (see also Vol. IV, 2516; Va, 193d).

The general characteristics of groundnut oil and of some other seed fats which resemble it

in their contents of saturated and linoleic acids are given in Table XII. The component acids of the two main types of groundnut oil are illustrated in Table XII. Of the three other oils quoted, only that of the Tonka bean resembles groundnut oil in containing appreciable proportions (about 14%) of arachidic and higher saturated acids in its glycerides.

TABLE XII.—OLEIC ("NON-DRYING") FATTY OILS: GROUNDNUT-OIL TYPE.

Fat.	Species.	Habitat.	Fat content	Sap. value.	Iodine value.	Chief component acids.		
						Saturated, %.	Oleic, %.	Linoleic, %.
Groundnut.	<i>Arachis hypogaea</i> .	India, W. Africa.	40-50	189-196	85-98	8	56	26
Tonka bean.	<i>Dipteryx odorata</i> .	E. Indies.	25	190-195	76-80		65	17
Pistachio.	<i>Pistacia fora</i> .	Asia.	45-60	191-192	86-93	25	60	15
Cashew nut.	<i>Anacardium occidentale</i> .	Tropics.	40-55	187-200	80-90	10	70	20
						10	70	20

(iv) Rape and mustard oils.—These fatty oils differ from those dismissed above in that, in addition to oleic and linoleic acids, they contain considerable quantities (40-50%) of erucic acid ( $A^{13}$ -docosenic acid,  $C_{22}H_{42}O_2$ ) in their glycerides. They also frequently contain more linoleic acid than, for instance, groundnut oil and are on the border line between "non-drying" and "semi-drying" oils. These oils occur in seeds of different species of the *Brassica* genus belonging to the family *Cruciferae*. They have considerable application as edible oils, lubricants and, at least formerly, as illuminants for railway and other lamps.

The most important of the group from a technical standpoint is rape oil (*colza oil*), from the seeds of *Brassica campestris*, cultivated widely in south-eastern Europe, India, and elsewhere. Oils from other varieties of *B. campestris*, such as *ravison* or *Danubian rape-oil*; and *Jamba rape-oil*, are somewhat inferior to rape oil, either in consequence of higher propor-

tions of linoleic or linolenic acid, or of the presence of organic sulphur compounds which are difficult to remove during refining.

*Mustard-seed oils* (from *B. (or Sinapis) nigra* and *alba*) are very similar in character to rape oil and are produced on a fairly large scale in some parts of India; but rape oil, with an annual world production of perhaps 200,000 tons, is the most important commercial fatty oil in this group.

The chief characteristics of these oils are illustrated in Table XIII; in addition to the major component acids, all the fats contain minor quantities of linolenic acid (up to 5 or 6%) and of saturated acids (3-5%, mainly palmitic with traces of behenic or lignoceric). Rape-oil glycerides conform with the usual rule of "even distribution," and consist largely of a mixture of di-erucins and "oleo"-erucins (in which "oleo"- may be either an oleic or a linoleic group).

TABLE XIII.—OLEIC ("NON-DRYING") FATTY OILS: RAPE-OIL TYPE.

Fat.	Habitat.	Fat content (M.D.) %.	Sap. value.	Iodine value.	Chief component acids.		
					T	Linoleic, %	Erucic, %
rape seed.	S.E. Europe, India, E. Indies.	35-46	172-175	94-106	17-20	25-29	47-51
Ravison seed.	S.E. Europe.	33-40	173-181	105-120	20	25	47
Jamba rape.	India.	26-33	109-175	95-102	29	12	46
Mustard black.	India, Europe.	31-33	173-176	96-107	25	20	50
„ white.	„ „	25-30	170-178	93-109	28	15	52

(e) Castor Oil (v. Vol. II, 420a) stands apart from the other "non-drying" oils, since its component acids contain 90% or somewhat more of the hydroxyoleic, ricinoleic acid. Consequently its glycerides include about 75% of triricinolein, the remainder being made up of two ricinoleic radicals with one radical of Palmitic, oleic, or linoleic acid. The hydroxyl group in the ricinoleic glycerides causes castor oil to be much more viscous than the rest of the vegetable oils and to be comparatively soluble in alcohol. It is also responsible for the value

of castor oil as a lubricant for special purposes (notably internal-combustion engines) and as a source of sulphated derivatives used in the dyeing industry, as textile detergents, and in the leather industry. In addition to these technical uses castor oil, in its highest grades is of course largely used in medicine.

The genus *Ricinus* is practically the only source of seed fats rich in ricinoleic acid. Glycerides of this acid have only been definitely reported in the case of two other fatty oils, the seed fat (ivory-wood oil) of *Agonandra brai-*

*liensis* (Olacaceae), which is stated to include nearly 50% of ricinoleic acid in its component acids, and the seed fat of *Cephalocroton cordo-Janus* (Euphorbiaceae), from the Sudan, which contains about 30% of ricinoleic and about 55% of oleic acid.

(by LINOLBIO OR "SEMI-DRYING" TYPE.

In the older classification of fatty oils according to their behaviour to atmospheric oxygen the term "drying oils" was given to those which absorb oxygen more or less readily, but when completely oxidised in thin layers are converted into a hard, non-sticky film. The "non-drying" oils, on the other hand, are slowly attacked by atmospheric oxygen but, even when oxidation at the ordinary temperature is advanced, remain liquid, albeit with considerable increase in viscosity. Between these two groups come the "semi-drying" oils, which take up oxygen more or less as do the "drying" oils, but which give final products which are stiff, tacky, and semi-gelatinous, and do not yield by any means completely hard and rigid dried or oxidised oil films. Needless to say, there is no sharp demarcation between either of the three groups, and some borderline fatty oils have been variously allocated as "non-drying" or "semi-drying," and others as "semi-drying" or "drying," respectively.

Broadly speaking, the "non-dryings" oils, richest in oleic acid, do not contain more than 20-25% of linoleic acid; whilst the characteristic "drying" oils may be said always to include some linolenic (or other triethenoid) acid in addition to linoleic acid. In the present article we shall consider as belonging to the linoleic or "semi-drying" group seed fats the component acids of which contain no linolenic acid but include from about 40-70% or more of linoleic acid. Within this group there are perhaps three fairly well-defined kinds of fatty oils:

- (i) Oils of the cottonseed type, in which large proportions (40% or more) of linoleic acid are accompanied by 20% or more of saturated acids (usually almost wholly palmitic acid);

- (ii) Cereal oils of the maize type, in which the proportion of saturated acids is lower (usually 12-15%), with somewhat varying proportions of linoleic acid (from 40% upwards);

- (iii) Seed fats in which 60-70% of the component acids is linoleic acid.

(i) *Oils of the cottonseed type.*—Cottonseed Oil (v. Vol. III, 408d) is the most important member of this group, since it is available in large quantities as a by-product after the fibre has been harvested for textile manufacture from the cotton crop. *Kapok oil*, from the seeds of *Eriodendron* and *Bombax* species, is very similar in composition to cottonseed oil and has been used to a certain extent in place of it.

The component acid? of cottonseed oil, which exhibit remarkable constancy between different varieties of the cotton plant or between the crops in different seasons or on different soils from the same strain of seed, contain 45-50% of linoleic, 25-30% of oleic, 20% of palmitic, and about 5% of myristic and stearic acids. The component glycerides are largely mono-palmitodimethylated derivatives, the chief component being probably palmito-oleo-linolein; about 25-30% of oleolinoleins are present together with a few per cent. of oleo- or linoleo-dipalmitins. On hydrogenation the linoleo-groups are normally converted into oleo- or oleo-oleo-groups before any substantial conversion of oleo- into stearo-groups occurs, so that at a certain point the hydrogenated fat will consist of about 60-65% of palmito-oleins or -iso-oleins with about 25-30% of oleo-oleo-cisins; thereafter oleo- and iso-oleo-palmito-stearins and oleo- and linoleo-stearins commence to accumulate and eventually, of course, palmito-distearins, oleo- or iso-oleo-distearins, and tristearin.

*Kapok Oil* (v. Vol V, 169a).

A fairly large number of seed fats from various plant families and indigenous to various parts, usually tropical or sub-tropical, have somewhat similar compositions to that of cottonseed oil. Although few, if any, of these have so far found technical application, particulars of some of them are given in Table XIV.

TABLE XIV.—LINOLEIC ("SEMI-DRYING") FATTY OILS: COTTONSEED TYPE.

Fat.	Species.	Habitat.	Fat content (seed), %	Smp. value.	Iod/ie value.	Chief component acids.		
						Saturated (palmitic), %	Oleic, %	Linoleic, %
Cottonseed.	<i>Gossypium</i> sp.	U.S.A., India, Egypt.	35-40	191-196	103-111	25	25-30	50-45
Kapok.	<i>Eriodendron</i> sp.	Sudan, E. Indies.	35-40	189-196	86-98	18-25	50-45	30-25
Kenaph seed.	<i>Hibiscus cannabinus</i> ,	Egypt, India.	20-25	187-190	90-99	20	50	25
Okra seed.	<i>H. isciuentus</i> .	Tropics.	25-30	195-198	93-100	30	45	25
Star aniseed.	<i>Illicium</i> sp.	E. Indies.	15-20	193-194	90-93	25	60	15
Grape fruit seed.	<i>Citrus decumana</i> .	Sub-tropics.	30-40	197-200	96-101	30	20	50
Oonyo almond.	<i>Anthrocaryum nannani</i> .	Congo.	65-70	200	85	25	45	25
Talisoy.	<i>Terminalia catappa</i> .	E. Indies, W. Africa.	48-50	187-200	77-82	35	40	25
Melon.	<i>Cucumis melo</i> .	Tropics.	30-40	190-193	117-130	15	25	55
Squash.	<i>Cucurbita maxima</i> .	Sub-tropics.	45-48	190-196	120-130	18	35	45
Pumpkin.	<i>C. pepo</i> .	"	45-48	195-196	126-130	30	25	45
Water melon.	<i>C. vulgaris</i> .	Tropics.	35-40	190-195	100-110	25	45	25
Chicory.	<i>Cichorium intykus</i> .	India.	30-35	190-195	120-130	20	35	45

(Si) 'Cereal oils of the maize type'—The seeds of\* the commonly cultivated cereals have endosperms with comparatively low fatty\* contents, but the germ usually contains fairly high proportions of fat. Little technical use is made of the fatty oils, except in the cases of maize oil and wheat-germ oil, the latter being valued chiefly as a source of vita\*nin-2£. Data for the composition of most of the seed fats of the

common cereals have been reported, and some of these are *givCn* in Table XV.

Maize Oil (v. VII, 470c) is usually termed *corn oil* in the United States.

Most of the cereal oils contain as component acids some 12-15% of palmitic and stearic acids (mainly the former), the remaining 85% or so of acids consisting of oleic and linoleic acids in proportions which vary considerably in different

TABLE XV.—LINOLEIC (" SEMI-DRYING ") FATTY OILS : CEREAL TYPE.

Fat.	Species.	Habitat.	Fat content. %.	Sap. value.	Iodine value.	Chief component acids.		
						Saturated, %.	T.	Linoleic, %.
Maize germ.	<i>Zea m&amp;y&amp;</i>	Sub-tropics.	40-50	188-193	117-130	12	45	42
Wheat germ.	<i>Triticum vulgare.</i>	Temperate zones.*	12-17	183-190	115-120	15	30	45-50
Rice,	<i>Oryza sativa.</i>	Tropics.	8-15	183-192	100-108	15-20*	40-45	30-40
toley germ,	<i>Uordeum vulgare.</i>	Temperate zones.	5-6	181-183	115-125	15-17	20-30	55-60
fat germ,	<i>Aispna saliva.*</i>	» » »	4-5	180-192	105-115	10	60	30
Rye germ.	<i>Secale dreale.</i>	» » »	8-11	185-196	100-105	15-20	20-35	50-60

species, and frequently in the endosperm and germ oils of the same species.

(iii) *SSed-fats containing 50% or more of linoleic acM.*—A number of technically useful oils belong to this group, in which (as\*in,cottonseed oil) linoleic acid is the chief component, but here it usually forms more than half of *tho* total fatty acids; oleic acid is also generally present

in fairly large proportions, the saturated acids (palmitic and stearic) being correspondingly comparatively small in proportion. Sesame, sunflower seed, poppy seed, and perhaps nigerseed oils are those which have found application in the fat industries, but a number of other seed fats fall in this group and are listed for reference in Table XVI.

TABLE XVI.—LINOLEIC (" SEMI-DRYING ") FATTY OILS CONTAINING 50% OR MORE OF LINOLEIC ACID.

Fat.	Species.	Habitat.	Fat content. %.	Sap. value.	Iodine value.	Chief component acids.		
						Saturated, %.	T.	Linoleic, %.
Sesame.	<i>Sesawim itidicum.</i>	India, E. Indies, Asia Minor, etc.	50-55	188-195	103-111^	15-16	37-45	40-47
Sunflower seed.	<i>Selianthus annus.</i>	S.E. Europe, Asia, S. Africa.	22-82	186-194	127-136	7-10	30-35	55-65
Poppy seed.	<i>Papaitr somniferum.</i>	India, Persia, China, etc.	45-50	189-196	132-143	8-10	25-30	62-65
Niggr seed.	<i>Guizotia abyssinica</i>	India, Central Africa.	35-40	189-198	126-134	9-12	20-35	55-70
Grape seed.	<i>vSis vinifera.</i>	Sub-tropics and m3d temperate zones.	20-22	189-200	125-140	8-15	20-35	50-70
Henbane.	<i>Hyoseyamus fuiger.</i>	Europe, etc.,	34-35	180-188	132-138	7	10-20	73-82
Tobacco seed,	<i>Nicotiana tabacuib</i>	Sub-tropics.	30-35	193-198	436-142	8-15	17-18	56-75
belladonna.	<i>Atropa belladonna.</i>	Europe, etc.,	©10-15	191-195	138-145	8	2	67
Thorn apple.	<i>Datura stramonium.</i>	Sub-tropics.	20-25	186-194	109-113	11-12	33-40	45-55

Sesame Oil (*teel oil*) is produced on a fairly extensive scale (100,0(50-150,000 tons annually) from seed grown^in India, China, the East Indies, the Levant, and parts of East and West Africa.<sup>9</sup> It^js used as a margarine fat, and in some countries the presence of a proportion of sesame oil in margarine is compulsox'y in order that the margarine may be readily detected as such by the application of the Baudouin colour test, characteristic\* for sesame\* oil (v. Vol. II, 1676).

Sunflower-seed Oil is on the borderline between "semi-drying" and "drying" oils, but does not contain any linolenic acid. The chief source? of the seed is Southern Russia and some of the Balkan\*countries, but it is also grown

elsewhere in Eastern Europe and in parts of Asia and South Africa. The seed contains about 30% of oil, and *the* annual production of the latter is probably of the order of 250,000 tons. Sunflower-seed oil, after refining and deodorising, yields a product notably free from colour, odour, and flavour which, in spite of its rather high linoleic glyceride content, is useful as a margarine fat. The oil is also employed for soap, and has also been used, blended with Unseed oil or other drying oil, as a paint oil. Sunflower-seed cake, after extraction of the-ML, has high value as a cattle food.

Poppy-seed Oil (v. Vol. IV, 854).

Niger-seed Oil, a West African product, has appeared on the market as an oil which can be

substituted for, or better blended with, linseed oil or other drying oils for use by the paint industries. It contains no linolenic acid, but its content of linoleic acid approaches 70% of the mixed fatty acids, and the bulk of the oil appears to consist of dilinoleo-oleins with a smaller proportion of dilinoleo-saturated glycerides. There appears to be good possibility of the development of niger-seed oil or fatty oils of similar composition as additions to the oils which may be capable of utilisation in paints and varnishes.

(C) LINOLENIC OIL " DRYING " TYPE.

The fatty oils falling in this group contain, in addition to varying and usually substantial amounts of linoleic acid, a certain proportion, sometimes large, of the triethenoid linolenic acid, and also stearic and myristic acids. Those with 20% or more of linolenic acid in the component acids of the oils are the typical " drying " oils, of which Unseed oil is the most common and the best known. Perilla oil is still richer in linolenic glycerides, whilst other seed fats, including the fatty oils from stillingia, hemp, rubber, and candlenut seeds, contain from 15-30% of linolenic acid and are characteristic " drying " oils. Finally, there are a number of other fatty oils which are less effective in their drying properties and, from this point of view, approach the oils rich in linoleic acid (e.g., sunflower or niger-seed oils) previously discussed; the fatty oils included in the present group are differentiated from the latter, however, in that they contain small proportions (although in some instances only 1 or 2%) of linolenic acid.

(i) *Fatty oils with 50% or more of linolenic acid (linseed and perilla oils)*—Linseed Oil (v. Vol. VII, 320a; see also DRYING OILS, Vol. IV, 886).

The average composition of the mixed fatty acids in linseed oil approximates to: saturated (palmitic and stearic) 10-15, oleic 15-25, linoleic 15-20, and linolenic 45-55%. The mixed glycerides present include about 40% of mixed linoleo-linolenins, the remaining 60% containing, for the most part, one saturated or one oleic group and two radicals which may be either linoleic or linolenic. Nearly all the triglyceride molecules thus contain at least two polyethenoid groups (of which the greater part is likely to be linolenic radicals), and this doubtless contributes to the excellent drying properties of linseed-oil films.

Raw linseed oil contains a minute, but effective, proportion of natural anti-oxidant compounds which retard the onset of atmospheric oxidation and cause the development of a preliminary " induction period " before drying sets in. This effect is obviated by heating the oil with lead, cobalt, or manganese linoleates or resinates (*boiled linseed-oil*).

Linseed oil, and other oils containing linolenic glycerides, are also altered by heating at about 270-290° without oxidation taking place concurrently. This process consists in a gradual polymerisation of the polyethenoid glycerides, probably preceded by isomeric rearrangement of non-conjugated into conjugated polyethenoid systems. At first considerable reduction in

apparent unsaturation (as measured by iodine value) takes place accompanied by slight, but not marked, increase in viscosity; subsequently slower reduction in iodine value occurs; but the oil rapidly becomes much more viscous. These heat-polymerised or " heat-bodied " oils are known as *stand oils*.

Perilla Oil (v. Vol IV, 846).

(ii) *Fatty oils with 15-35% of linolenic acid*.—Rubber-seed Oil, from the seeds of *Hevea brasiliensis*, has good drying properties suitable for the paint industry and its use might be extended if the oil were produced on a sufficiently large scale, with modern technique. The present production, probably of about 20,000 tons annually, is capable of much enlargement since the seeds may be regarded as a by-product of the natural rubber industry. The whole seeds contain about 30%, and the kernels about 50%, of fatty oil. The oil is at present imported is frequently dark-coloured and often contains, several per cent, of free fatty acid, whilst the unsaponifiable matter includes some hydrocarbons of a poly-isoprene character. Collection of seed and its extraction by modern procedures would doubtless improve the quality of the oil, and possibly reduce or eliminate the small amount of rubber hydrocarbons present, leading to an oil of good value for paints and varnishes. The fatty acids of rubber-seed oil include 15-20% of linolenic and 35-45% of linoleic acid.

Stillingia-seed Oil (v. Vol. III, 336).

Candlenut or Lumbang Oil (v. Vol. II, 262). Although belonging to the genus *Aleurites*, other species of which are rich in the conjugated oleo-tearic glycerides (v. *Sifra*), this seed fat of *A. moluccana* contains none of the latter, but its component acids include about 2-3% of linolenic and 40-50% of linoleic acid. It is a " drying " oil of similar nature to the two preceding fats, and its production is capable of development on a considerable scale.

Hemp-seed Oil (v. Vol. VI, 203a). The composition of hemp-seed oil seems to vary somewhat, 15-30% of linolenic acid and 50-70% of linoleic acid having been reported in its component acids.

The seed fats of *Sweet Basil*, *Ocimum basilicum*, grown in India, and of the Mexican *Chia*, *Salvia hispanica*, and other members of the sage family grown in India, have similar fatty components to the preceding oils, and there are probably other members of the *Labiatae* and of other plant families, whose seed fats fall within this or the previous group, and would be capable of functioning as technical " drying " oils.

(iii) *Fatty oils with less than 15% of linolenic acid*.—Walnut Oil, like poppy-seed oil (v. Vol. IV, & 5d) has been a favourite medium with artists for paints, owing to its pale colour and the absence of development of colour in the dried oil film. It forms over 60% of the kernels of the walnut, but the annual production is relatively small. The component acids include only 2-3% of linolenic with about 60-70% of linoleic acid and the oil is comparatively slow in " drying."

Safflower Oil (Vol. IV, 866), from safflower seeds grown mainly in India and in South-Eastern Europe, is a " drying " oil of similar

composition to walnut oil. The potential production of the oil is quite large and the best safflower oil is pale-coloured and of high quality when refined/ but hitherto it has not been used in Europe on any ver^ extensive scale.

Soya &ean Oil (v. Vol.IV,84d; VII, 194a) is a\* very important oil, classed more often as a "semi-drying" than as # "drying" oil, but why'de in virtue of its small linolenic acid content has definite drying properties and has been used for blending with or "extending" linseed oils. It is also serviceable as a margarine fat and, when partly hydrogenated, is used both in margarine and cooking ("shortening") fats, whilst the raw and partly hydrogenated oils also find application as soap-making materials. Soya-Dean oil forms 15-20% of the endosperm of ohe soya bean, a legumiflor.s plant indigenous to Manchuria \*and Northern China, and now cultivated in many parts of the world, including the

United States, the East Indies, South Africa, and some other parts of the British Empire; the climate and soil of Great Britain, however, appear to be unsuited to the soya bean as an economic crop. The composition of the oil varies somewhat with the locality in which it is cultivated, but on the average the component acids include 5-6% of linolenic and somewhat over 50%\*of linoleic acid.

Amongst other fatty oils which, like the above, contain 50% or more of linoleic acid together igitly a few per cent, of linolenic acid, and therefore share the properties of moderately good "drying" oils, may be mentioned *Argemone oil* from the prickly poppy found in Mexico, the southern parts of the United States, the West Indies, India, etc. It forms about 35% of the seeds and could be produced in quantity.

The general characteristics of the foregoing oils are summarised in Table XVII.

TABLE XVII.—LINOLBNIO (" DBYINO ") FATTY OILS.

Fat.	Species.	Habitat.	Fat content, %.	Sap. value.	Iodine value.	Chief component acids.			
						Saturated, %.	Oleic, %.	Linoleic, %.	Linolenic, %.
Linseed.	<i>Linum usitatissimum</i> .	Argentina, Russia, India, U.S.A.; Canada, etc.	35-40	189-196	170-185	10-15	15-25	15-20	45-55
Perilla. N'gart seed.	<i>Perilla ocimoides</i>	Japan, E. Indies.	35-45	187-197	180-206	7-10	15-20	0-10	65-70
Rubber seed.	<i>Tetradium conophorum</i> .	Nigeria.	45-50	195-200	200-206	7-10	13-14	12-16	63-65
Stillingia seed.	<i>Stillingia setifera</i> .	S. America, E. Indies.	50	186-196	127-144	17-20	25-30	35-45	16-25
Candlenut.	<i>Aleurites mifucana</i> .	China, India.	40-50	203-210	146-170	7-9	12-16	46-53	28-29
Hempseed.	<i>CannabU saliva</i> .	E. Indies, Brazil.	55-65	189-195	155-165	9-10	10-30	40-50	20-30
Sweet Basil.	<i>Ocimum basilicum</i> .	Russia, S.E. Europe, India, N. America.	30-35	190-195	145-165	9-10	10-15	50-70	15-30
Chia seed.	<i>Salvia hispanica</i> .	India.	25-30	190-195	150-165	7	11	60	21
Walnut.	<i>Juglans regia</i> .	Mexico.	25,35	190-195	180-190	8	Traces	49	42
Safflower.	<i>Carthamus tinctorius</i> .	Temperate and sub-tropics.	63-65	190-197	140-150	6-8	20-30	60-70	2-3
Soya bean.	<i>Soia hispida</i> .	S.E. Europe, India.	25-32	187-194	130-150	5-10	17-26	68-71	1-3
Argemone.	<i>Argemone mexicana</i> .	Asia, U.S.A., etc.	15-20	190-193	124-133	12-13	25-30	50-55	5-8
		Mexico, India.	34-38	187-190	119-122	15	22	48	1

(d) CONJUGATED (" DRYING ") TYPE.

There remain a few interesting "drying" oils which differ in character from the linolenic group because their glycerides contain large amounts of the tri-conjugated elaeostearic or Ucanic (feto-elaeostearic) acids, or, in a few rare instances, of conjugated tetra-ethenoid parinaric acid. The most important of these is China-wood or tung oil.

Tung Oil (*China-wood oil*) (v. Vols. I, 1986; IV, 82c, 896).

Elaeostearic acid forms about 80% of the component acids in tung oil, which therefore contains a fair proportion of the glyceride tri-elaeostearin, the rest of the fat consisting of the conjugated elaeostearic groups with one of oleic or saturated (e.g., palmitic) acid. On exposure to air these glycerides

oxidise and polymerise to yield films of a more massive character than linseed-oil films.

Tung oils have a saponification value of about 189-195 and an iodine value (Wijs) of 160-180, but the latter is low and indefinite, since the Wijs or Hanus reagent does not interact quantitatively with the conjugated unsaturated groups. Use of a special iodine-value technique (Woburn) gives more accurate values, but better methods of estimation of conjugated unsaturation in tung and similar oils consist in the determination of the maleic anhydride value or of the intensity of the absorption spectrum band at 270 m $\mu$ . (c. p. 14d). The presence of the conjugated unsaturated system causes tung oil to possess a higher refractive index (n<sub>D</sub> 1.523) than oils in which this system is not present (e.g., linseed oil, n<sub>D</sub> 1.484).

Other seed fats which have been observed to contain substantial proportions of elaeostearic acid include the following:

**Bagilumbang Oil**, from the seeds of *Aleurites trisperma*, a species grown in the Philippine Islands and the East Indies, and containing in its fatty acids nearly 70% of elaeostearic acid, and about 15% each of saturated and of oleic acid.

**Essang Oil**, from the seeds of *Ricinodendron africanum*, a West African shrub whose kernels contain about 50-55% of oil, the component acids of which include about 50% elaeostearic, 10-15% each of saturated and oleic, and about 25% linoleic acids.

**Neou Oil**, from the seeds of *Parinarium macrophyllum*, also a West African plant, contains only about 30% of elaeostearic acid, with about 10% saturated, 40% oleic, and 15% linoleic acid; whilst *po-yoak* oil, from the related *P. sherbramse*, contains 32% elaeostearic, 8% oleic, 12% saturated, the remaining 48% being licanic acid.

Licanic or keto-elaestearic acid is, however, the chief component acid in the seed fat of *Licania rigida*, a forest tree which grows abundantly in parts of Brazil. This seed fat is termed *Oiticica Oil*, and has come into some prominence recently as a substitute for tung oil (v. Vol. IV, 84a). Its component acids are made up of nearly 70% licanic, with 5-6% oleic and 11-12% saturated acids; it contains comparatively little tri-keto-elaestearin, the bulk of the oil consisting of glycerides with two keto-elaestearic groups and an oleic or palmitic group. Consequently it dries and gelatinises somewhat more slowly than tung oil. Moreover, the presence of the hydrophilic keto-group appears to affect the properties of the oiticica varnish film, which is more permeable to moisture than a tung-oil film.

In addition to *po-yoak* oil from the West African *Parinarium sherbramse* (referred to above), the seeds of an East Indian species, *P. corymbosum*, are rich in licanic-acid glycerides, the component acids of this seed fat including about 60% of licanic, 15% elaeostearic, 5% linoleic, 8% oleic, and 12% of saturated acids.

Reference should be made finally to two seed fats of other species of *Parinarium* (*P. glaberrimum* and *P. laurinum*) which are reported to contain large quantities (70% or more) of the conjugated  $J_9 \gg J_{11} \gg J_{13} \gg J_{15}$ -octadecatetraenoic or parinao acid. These seed fats are apparently solid at the ordinary temperature, but are obviously of considerable interest as regards their possible properties, for example, when blended with drying oils of either the linseed oil or the tung oil groups. At the moment, however, they remain in the category of rare seed-fats, the uses of which have not yet been exploited.

## LAND-ANIMAL FATS.

### I. BODY FATS.

#### BODY FATS OF PIGS, OX, AND SHEEP.

The general features of the composition of the body or storage fats of land animals have already been described (pp. 6c-8 and Table I). \* So far

as individual fats of technical importance are concerned, only those of the pig (lards), ox, and sheep (tallow) require detailed attention since, with bone fats and neat-foot oil (v. Vol. VI, 250d), these are practically the only animal body-fats which find industrial use at present.

**Pig Body-fat** (see also LABD, Vol. VII, 185c) is deposited chiefly in the subcutaneous tissues of the back and rump, and as perinephric fat surrounding the kidneys.

The iodine value of perinephric pig-fat ranges from about 48-53, and that of the innermost layers of the back fat is similar; but the outer layers of back fat are more unsaturated and may have iodine values up to about 65-70. Consequently lards produced from different sites in the animal may vary a good deal in consistency, from the very soft outer back-fats to the perinephric fats which are firm, although by no means hard, white solids at the ordinary temperature. Such variations have been found, on detailed analysis of the component fatty acids of pig body-fats, to consist almost wholly in the replacement "as it were, of some of the oleic acid present in a pig outer back-fat by stearic acid in the case of more saturated pig-fats. Thus the total fatty acids of a perinephric or of an inner back-fat from a pig may include 00-44% of oleic and 16-13% of stearic acid, whilst those of the outermost layers of back fat may contain 46-52% of oleic and 13-8% of stearic acid. The other main component acid is palmitic, the content of which is relatively constant at about 20-30% but may fall some units per cent, below the lower limit given in the case of very soft outer layers of back fat. There are, in addition, a few minor component acids present in pig body-fats as follows: octadecadienoic (including ordinary linoleic acid and probably isomeric forms) 6-13%; myristic 1-2%; tetradecenoic traces, hexadecenoic 2-3%, and highly unsaturated acids of the  $C_{80}$  and  $C_{22}$  series, 1-2%. The proportions of these minor component acids vary but little with the source of the fat; but the higher quantities of octadecadienoic acid have only been observed in the case of sows several years old when killed.

The above figures for component fatty acids refer to fats from pigs fed on diets low in fat; it has been shown (Hilditch and Pedelty, Biochem. J. 1939, 33, 493) that in these circumstances very much of the body fat has been synthesised in the animal from non-fatty (carbohydrate) constituents of the diet. Typical data for pig body-fats of this nature are quoted from the work of Hilditch and colleagues in Table XVIX.

Animals are able to assimilate and store fats present as such in their diet, and the pig is a particularly good illustration of the fact that directly assimilated fat, as well as fat synthesised by the animal, is utilised as body or depot fat. Some data given by Ellis and co-workers (J. Biol. Chem. 1926, 69, 239; 1930, 89, 185; 1933, 92, 385), summarised in Table XIX, show that in extreme instances of fatty diets the greater part of the body fat is derived from dietary fat, and includes some of the specific fatty acids of the latter which are not present in ordinary pig-fats.



TABLE &VIII.—COMPONENT ACIDS (% WT.) OF BODY FATS, pF PIGS ON LOW FAT DIETS:

Tissue	Sex	Age	Iodine value	Component acids						
				Mystic	Palmitic	Stearic, %	Hexadecenoic, %	Oleic, %	Octadecadienoic, %	C <sub>20-22</sub> unsaturated, %
Perinephric	M	7 months.	52.4	1.1	30.4	17.4	16	41.2	5.7	2.1
	M	"	56.4	0.9	29.3	17.4	21	40.3	8.1	1.9
	V	Several years	59.0	3.9	27.7	17.6	*	35.7	13.7	1.4
Inner trunk	F	6 months.	54.3	1.0	30.4	16.2	3.0	40.9	7.1	1.7
	M	"	58.9	0.9	27.5	15.1	1.9	44.2	7.3	3.1
	F	Several years	63.0	2.8	25.5	14.5	1.9	42.8	13.7	1.4
Outer bark	F	6 months.	60.0	1.3	28.3	11.9	2.9	47.5	6.0	2.1
	M	"	58.8	0.7	25.3	13.1	2.1	51.0	5.3	2.5
	M	"	63.9	1.0	26.5	12.8	2.1	46.8	7.9	2.9
	F	Several years	70.4	2.6	23.8	10.1	*	46.3	15.2	2.0
	F	"	72.6	3.8	21.0	7.9	*	54.1	13.0	0.9

Hexadecenoic included with oleic acid

TABLE XIX.—SATURATED ACIDS (% WT.) OF BODY FATS OF PIGS ON FATTY DIETS.

Diet	Iodine value	Chief component acids						
		Mystic, %	Palmitic, %	Stearic, %	Arachidic, %	Oleic, %	Linoleic, %	Linolenic, %
Basal diet low fat	58.8	9.9	25.2	12.7	—	54.4	7.0	—
" " +12% cottonseed oil.	60.6	1.1	25.5	13.7	—	50.2	8.9	—
Basal diet +12% cottonseed oil.	77.4	1.1	13.8	26.5	—	31.8	26.8	—
Soya beans alone.	100.6	0.3	14.1	7.7	—	38.9	38.3	0.5
Groundnuts alone.	84.1	0.4	15.5	7.5	0.2	56.9	10.5	—

The most abundant component glyceride of pig body-fats is palmitodistearin, which forms 45-55% of the whole fat; oleopalmitostearins come next, amounting to 25-35% of the fat. The remaining 20% is made up of stearodistearin, oleodipalmitin, and minor amounts of triunsaturated glycerides, and palmitostearin. The proportion of fully-saturated glycerides and also of stearo-glycerides is lowest in the most unsaturated outer back-fats and increases progressively in the harder varieties of perinephric and femur back-fats of the pig. The general progressive increase in relatively saturated stearo-glycerides in the stearic-rich depot fats of the pig, ox, and sheep is illustrated later in Table XXI.

Ox and Sheep Body-fats, known technically as beef and mutton tallow, are similarly derived either from the perinephric tissues (suet) or from the external subcutaneous tissues of the neck and flanks of the animals. The best qualities of beef tallow, termed premier, just have been very largely used in margarine (v. Vol. VII, 509a); other grades, made by rendering the tissues at higher temperatures or with water in autoclaves, form excellent material for soap-making and for conversion to "stearines" (the distilled saturated—palmitic and stearic—acids of the tallow) for incorporation in candles. Mutton tallow is similarly employed, but to a lesser extent than the ox fats, for soap-making. The lowest grades of tallow, from the suet autoclave or other rendering of tissues from which the better qualities of fat have already been extracted, are used in some types of lubricating greases (v. ch. VI, 134c). The bone-fats of

sheep or oxen contain fatty matter which is removed prior to their conversion into glue and bone meal, and the bone greases BO obtained are also used in lubrication and, in some of the better qualities, as material for lower grade soaps. Commercial bone-fat is usually, owing to its source and mode of production, of inferior quality, but the composition of fresh bone-fat appears to differ but little from that of a soft tallow (cf. Table XX).

The iodine values of the perinephric or suet fats is usually about 40-45, and of the external tissue fats from 45-52. The sheep fats tend to be somewhat more saturated than the corresponding ox fats. As in pig fats, variation in consistency and iodine value is due to the respective amounts of stearic and oleic acids in the total acids of the C<sub>18</sub> series, which are relatively constant at about 60-65% of the acids of the whole fats. The chief component acids of ox and sheep body fats are oleic (36-50%), stearic (28-14%) and palmitic, which is relatively constant in ox fats at 27-33%, and somewhat lower in sheep fat (24-26%). Minor component acids include lauric (traces), myristic (2-4%), tetradecenoic (traces), hexadecenoic (1-3%), octadecadienoic (not identical with seed fat linoleic, 1-3% in ox, and 3-6% in sheep), traces of arachidic and unsaturated C<sub>20</sub> and C<sub>22</sub> acids in ox fats, and up to 1% of unsaturated C<sub>20</sub> and C<sub>22</sub> acids in sheep fats. A small proportion of the acid reckoned as oleic in both ox and sheep body-fats is a solid isomeric octadecenoic acid termed *vaccenic acid* (Bertram, Biochem. Z. 1928, 197, 433).

It may be added that the above figures refer

to fats from animals reared in temperate climates, and that examination of some Indian ox depot-fats (Hilditch and Murti, Biochem. J. 1940, 34, 1301) of unusually low iodine values (26-31) has revealed the presence of up to 40% of palmitic acid in their component acids, the

stearic-acid content reaching a maximum at about 28%.

Typical data for the component acids of a range of ox and sheep body-fats from various countries, and of an ox bone-marrow, fat, are included in Table XX.

TABLE XX.—COMPONENT ACIDS (% WT.) OF OX AND SHEEP BODY FATS.

Fat.	Chief component acids.						
	Myristic, %.	Palmitic, %.	Stearic, %.	Hexadecenoic, %.	Oleic, %.	Octadecadienoic, %.	C20-22 unsaturated, %.
Ox (English, perinephric, I.V. 38-7).	2.7	30.4	23.7	2.1	38.6	2.0	Traces
„ (Indian, „ „ 31-0).	3.3	24.9	24.1	2.8	41.8	1.8	0.5
„ „ „ „ „ 26*5).	2.6	36.8	26.8	2.4	29.8	0.9	0.7
„ (N. American body).	4.6	41.4	24.3	1.7	26.4	1.0	0.1
„ „ „ „ „	2.5	32.5	14.5	•	48.8	1.0	•
„ „ „ „ „	2	25	20	•	47.5	5	•
„ (Australia, „ ).	2	26.5	22.5	*	49	—	•
Ox (Bone-marrow fat).	2.7	32.3	15%	1.7	43.2	2.6	Traces
Sheep (English, perinephric, I.V. 42-7).	2.3	26.2	27.1	1.3	38.7	3.3	5.1
„ „ „ „ „ 50*2).	2.9	24.0	24.9	3.1	39.2	5.2	11
„ ( „ body, „ „ 50*2).	4.0	28.3	13.5	0.8	50.8	1.9	0.7
„ „ „ „ „	3.8	27.8	14.7	2.0	46.3	4.8	0.7
„ (Australia, body).	2	25	23	•	47	3	0.6

Included with oleic acid.

As in pig fats, the chief component glycerides of ox and sheep body-fats are palmitodioleins (25-65%) and oleopalmitostearins (40-25%); stearodiolein and oleodipalmitin may each contribute from about 5-15% of the total glycerides, palmitostearins range from about 5-15%, whilst the simple triglycerides triolein, tripalmitin, and tristearin occur at most only in traces. These general figures refer to the usual types of tallows—the composition of the exceptionally saturated Indian ox-tallows is of course different. It has been remarked previously (p. 6d) that the stearic-rich animal depot-fats are consisted in

composition with what would result from partial hydrogenation or saturation of a preformed mixture of palmito-oleo-glycerides assembled on the lines of the "even distribution" which is prevalent in most other fats. This may appear more clearly from Table XXI, in which the approximate proportions, of the component glycerides in a series of pig, ox, and sheep depot-fats (in which the stearic acid content increases, and the oleic acid content decreases, progressively) are given. In this table the figures refer to molar percentages and minor component acids are included with major component acids

TABLE XXI.—COMPONENT GLYCERIDES (% MOL.) OF PIG, OX, AND SHEEP DEPOT FATS.

	Pig, back.	Ewe, back.	at perinephric.	c. OX, Eng. lish.	Ewe, perinephric.	Cow, Calicut.	Cow, Bombay.
<i>Component acids:</i>							
Palmitic	29.0	31.5	31.1	33.4	27.1	33.4	40.8
Stearic	13.8	14.5	17.6	21.4	25.6	27.9	25.5
Oleic (+octadecadienoic)	51.1	47.9	45.9	38.7	40.4	30.5	24.0
<i>Component glycerides:</i>							
<i>(i) Triolein</i>							
Stearodiolein	3	—	3	—	—	—	—
Oleodipalmitin	7	—	5	13	11	3	1
<i>(ii) Palmitodiolein</i>							
Oleopalmitostearin	53	46	40	23	25	17	—
Palmitodistearin	27	28	34	32	41	38	—
<i>(iii) Oleodipalmitin</i>							
Palmitodistearin	2	2	5	6	10	12	10
<i>(iv) Oleodipalmitin</i>							
Palmitodistearin	5	13	4	15	5	11	18
	2	3	4	8	4	16	23

as follows: myristic (and lauric) with palmitic, and stearic, and all minor unsaturated acids with oleic.

relatively high (7-15%) linoleic or octadecadienoic acid, whilst in addition small proportions (2-6%) of linolenic acid may be present. Horse fat in admixture with pig or beef fats is not easy to determine as such, but the presence of linolenic acid may be detected by production of the

Horse Body-fat (v. Vol. VI, 280a) as indicated in Table I, is a softer fat than those from the ox, and contains little stearic acid with

ether-insoluble hexabromostearic acid (Crowell, J. Assoc. Off. Agr. Chem. 1946, 27, 455), or by spectrographic examination after isomerisation with alkali (p. 2d).

The hqvves of oxen, Sheep, and horses contain a fatty oil (neats'-foot or \*trotter oil (w. Vol. VI, 2S0d)) which is extracted during their conversion' into glue and \*which has a certain 'te,ohnfbal importance. The name is applied to the foot oils from various animals, but strictly refers to the fat from the foot of the ox. Neats'-foot oil is a liquid fat of iodine value 67-73, valued for leather-dressing in the highest qualities of leather goods, and also (when chilled and pressed from deposited solid fats) as a high-grade lubricant for delicate machinery such as clockwork; as a lubricant, however, it is now frequently replaced by light petroleum spindle oils. Its uses for both technical purposes are governed mainly by the circumstance that the oil has practical^ no, "drying" properties, since it contains practically no linoleic or other polytheneid glycendes; further^ it contains much less saturated acids than the off depot fats (from which it differs entirely in composition) and consequently only very "small proportions of glycerides which separate from' the oil at the ordinary temperature. As already mentioned, these small proportions are frequently removed, by pressing the refrigerated oil prior to use) as a fobricant. The chief component acids appear to be palmitic (17-18%), stearic (2-3%), and oleic (74-76%) (Eckart, Z. Unters. Nahr.- u. Genusm. 1922, 44, 1).

Wool Fat, Wool Grease, or Wool Wax (v. WOOL GREASE, VOK'VI, 135C) should perhaps be mentioned here, if only as a reminder that it is essentially a wax and not a glyceridic fat\*. It is present in raw sheeps' wool to the extent" of about 20-30% and must be removed in the wool-scouring process before the wool can be handled by the textile industries. Very large quantities of the recovered wool grease are therefore available for trade purposes, when of sufficiently high quality it is refined and, under the name of lanolin, employed as an ointment and otherwise in pharmacy; much of the wool grease produced technically &, however, dark in colour and unpleasant in odour, with a high content of free acids. The material produced in the sebaceous glands at the base of the hair on the sheep's skin in common probably with some oilier glandular secretions (e.g., of the ear), is essentially a mixture of ester-waxes, wool grease consists mainly of esters of the alcohol cholesterol and cholesterol; the components do not belong to the normal fatty acid series (except in so far as palmitic and oleic acids may be very minor components), but are mainly saturated, with melting-points lower than those of the corresponding acids of the Un. Th. group. The nature of these acids is (Weil, J. Amer. Chem. Soc. 1945, 67, 447) altered by substitution of long-chain aliphatic acids (e.g., wata and Ishii, J. Soc. Chem. Ind. Jap. 1936, 39, 317B; Abraham and Hilditch, J. Soc. Chem. Ind. 1935, 39, 317B). The proportions contain about 26 carbon

atoms and belong to the saturated series; hydroxylated or lactonic acids of compositions approximating to  $C_{30}H_{60}O_4$ ,  $C_{30}H_{65}O_3$ , and  $C_{16}H_{30}O_3$  are also present in small quantities.

## II. BUTTER OR MILK FATS.

The milk fats (v. Vol. VIII, 117) of mammals differ considerably in their composition (cf. p. 32). In many animals the milk fat is probably not very different from the other body or storage fats, in others the proportion of lower saturated acids may reach a combined figure of 20-25% of the total acids. The amount of butyric and/or other lower saturated acids appears to be greatest in the case of ruminants, although these also occur in some degree in the milk fats of some other animals. Detailed figures for the component acids of milk fats are still very incomplete, except in the cases of those of the cow and of a few other animals. Comparison of the average Reichert-Meissl and Polenske values of animal milk fats serves, however, to give general indications respectively of the proportions of butyric and *n*-hexanoic (caproic), and of *w*-octanoic (caprylic) and *n*-decanoic (capric) acids. Typical data are as follows:

Milk fat.	Reichert-Meissl value.	Polenske value.
Dog	1-2	
Pig	1-7	
Human	1-4-3-4	1-5-2-2
Mouse	2-9	
Cat	4-4	
Horse	70	6-1
Ass	131	
Rabbit	16-1	
Camel	16-4	1-6
Goat	20-29	3-2-9-8
Sheep	23-33	2-2-6-9
Buffalo	26-34	1-6-2-4
Cow	33-36	1-3-3-5

It will be noted that human milk-fat contains only traces of the lower acids characteristic of cow milk-fat, and the partially quantitative work of Bosworth (J. Biol. Chem. 1934, 106, 235) confirms this and also suggests that it is closely similar in component acids to a typical animal body-fat of the softer type (i.e., relatively rich in oleic and poor in stearic acid). Recent data (Hilditch and Meara, Biochem. J. 1944, 38, 29) show that the component acids of human milk-fat include decanoic 2, lauric 6, myristic 8, palmitic 22, stearic 9, arachidic 1, tetradecenoic 0-5, hexadecenoic 3, oleic 37, octadecadienoic (including some linoleic) 8, and unsaturated  $C_{20}$  and  $C_{22}$  acids 3% (wt.).

So far as edible fats are concerned, cow-milk or butter fat. (« BUTTER," Vol. II, 1616) is of course by far the most important. Indeed, apart from native butters produced in a few districts of some countries from the milk of the buffalo, or, in some instances, of goats or sheep, it is the only form of butter fat which is prepared for human consumption. Its production probably still considerably exceeds" that of all the margarine fats prepared as butter substitutes, and for a number of reasons it seems likely to hold its place in popular esteem, in spite of the fact that from a nutritional standpoint, including vitamin content, modern margarines are undoubtedly equal to butter. Apart

from any remaining popular prejudice, freshly made butter possesses an attractive aroma or flavour which is difficult to reproduce completely in margarine, whilst by virtue of its specific mixture of mixed component glycerides it has a spreading capacity or "spreadability" which has not yet been equalled in margarines.

Butter from cows at pasture is normally richer in vitamins -A and -D than those from stall-fed animals in winter. By feeding appropriate concentrates of these vitamins, or ensiled green-fodder still retaining carotenoids from the original pasture-grass, however, winter butters of enhanced vitamin content can be produced.

So far as the composition of the fat itself is concerned, the chief component acids of cow butter-fats (as of the body fats) are oleic and palmitic, with subordinate amounts of myristic and stearic acids, characteristic (although individually small) proportions of butyric, caproic, caprylic, and capric acids, and minor amounts of lauric and arachidic acids, of an interesting series of lower  $\alpha$ -monoethenoic acids of the  $C_{16}$ ,  $C_{14}$ ,  $C_{12}$ , and  $C_{10}$  series,

and traces of highly unsaturated  $C_{18}$  and  $C_{20}$  acids. A small quantity of diethenoic  $C_{18}$  acid present is not identical with seed-fat linoleic acid, although the latter, may also be present in traces.

Data for all  $\alpha$ -B component acids of the wide range of cow butter fats are now available, and a few typical examples are quoted in Table XXII. Similar data for goat, sheep, and buffalo milk fats are also included (some of the minor component acids of the unsaturated series were not determined in the case of the buffalo milk fat). Owing to the wide variation in molecular weight of butter fatty-acids, comparison by weight percentages is misleading and therefore the molar percentages of the acids are also given. It is then seen that, whilst oleic and palmitic acids are the main components, butyric, myristic, and stearic acids each contribute about 10 molecules out of every 100 molecules of the mixed fatty acids of cow butter-fat. It will be noted that sheep and goat milk-fats contain larger proportions of capric (and caprylic) acids and less oleic acid, than cow or buffalo milk-fats.

TABLE XXII.—COMPONENT ACIDS OF MILK FATS.

(i) Cow Butter Fats.						
	Stall-fed (winter), % (wt.)	Pasture (summer), % (wt.)	Stall-fed (winter), % (mol.)	Pasture (summer), % (mol.)		
<i>Saturated acids:</i>						
Butyric	3-7	3-7	0-8	10-2		
Caproic	2-5	1-2	4-1	2-3		
Caprylic	1-6	0-5	1-0	1-3		
Capric	2-4	1-1	1-5	1-5		
Lauric	1-7	2-8	3-2	3-3		
Myristic	0-3	8-1	2-0	8-8		
Palmitic	22-4	22-5	9-0	21-1		
Stearic	10-1	1-1	23-7	0-0		
Arachidic	0-4	0-1	0-3	0-7		
<i>Unsaturated acids:</i>						
Decenoic	0-1	0-1	0-1	0-2		
Dodecenoic	0-1	0-2	1-2	0-2		
Tetradecenoic	1-2	0-8	1-3	0-1		
Hexadecenoic	3-0	3-0	4-0	2-8		
Oleic	32-4	31-8	27-0	31-4		
Octadecadienoic	4-0	5-7	3-3	3-9		
Unsaturated $C_{20-22}$	0-4	0-7	0-3	0-5		
(ii) Other Milk Fats.						
	Buffalo, % (wt.)	Goat, % (wt.)	Sheep, % (wt.)	Buffalo, % (mol.)	Goat, % (mol.)	Sheep, % (mol.)
<i>Saturated acids:</i>						
Butyric	41	30	25	10%	7-6	7-5
Caproic	14	2-5	2-8	2-3	4-7	5-3
Caprylic	0-9	0-9	2-2	1-5	4-3	2-8
Capric	1-7	1-0	4-8	2-4	12-8	6-4
Lauric	2-8	0-0	3-9	3-3	0-0	4-5
Myristic	10-1	12-3	9-7	10*	11-2	9-0
Palmitic	31-1	27-9	23-9	28-7	24-1	21-6
Stearic	11-2	0-0	12-6	0-3	4-7	10-3
Arachidic	0-0	0-6	0-1	0-7	0-0	0-8
<i>Unsaturated acids:</i>						
Decenoic	0-0	0-3	0-1	0-0	0-3	0-2
Dodecenoic	0-0	0-3	0-1	0-0	0-8	0-2
Tetradecenoic	0-0	0-8	0-0	0-0	0-0	0-6
Hexadecenoic	0-0	2-6	2-2	0-0	2-2	2-0
Oleic	33-2	21-1	21-3	27-7	10-6	21-6
Octadecadienoic	2-0	3-0	1-2	2-2	2-8	4-3
Unsaturated $C_{20-22}$	0-0	0-2	0-0	0-0	0-2	1-8

\* Included with oleic acid.

Some of the component acids of cow butter-fats, are subject to certain variations in proportion, these variations being connected, *inter alia*, with the following circumstances. The palmitic acid content, which is normally somewhat lower than in the depot fats and averages perhaps 25% of the total acid appears to fall gradually with increasing age and number of lactations of the animal; this decline in proportion of palmitic acid is compensated for partly by a slighter progressive increase in oleic acid content, and partly by still smaller increases distributed over the lower saturated and stearic acids. A more pronounced alteration is a seasonal one, due to the change in mode of life during winter as compared with summer, when the cattle are freely out at pasture. Towards the end of the winter the oleic acid content of cow milk-fat is at its lowest, but on going out to pasture there is an abrupt change both in the milk yield, in a slightly lowered fat content of the milk, and in the proportions of the chief component acids in the milk fat. The oleic acid of the last increases in the course of a few days at pasture by about 4 or 5 units per cent., compensated by slight decreases in most of the other component acids, including butyric acid. Throughout the pasture season the milk fat continues to be somewhat richer in oleo-glycerides than when the cattle are in their winter quarters. This difference seems to be the result of changes in conditions other than diet, since cows fed during winter on ensiled grass fodder show the same variation in milk-fat composition as those fed on roots or other typical stall-feed (Hilditch and Johnson, J.S.C.I. 1941, 60, 305).

In addition to the lower saturated acids from butyric upwards, cow milk-fat contains progressively diminishing proportions of hexa-, tetra-, and deca-decenoic acids, and decenoic acid, the amount of the two last acids being only a few fractions of 1%. In all four acids the unsaturation is in the disposition, as in oleic acid, in the form of a double bond that represents stages in the biochemical transformation of oleo-glycerides in the blood in which the oleo-radical has been shortened, two carbon atoms at a time from the terminal carboxylic end of the chain, and in which the terminal double bond has escaped concurrent saturation of palmitic, myristic, lauric, or capric groups. It is at the milk-fat glycerides are derived from the strides in the blood entering the mammary gland has been established by measurement of the glyceride in the blood before and after passage through the mammary glands of the cow (Graham, Jones, and Kay, Proc. Roy. Soc. 1936, B, 120, 220; Shaw and Petersen, J. Dairy Sci., 1938, 21, A, 12D).

When cows are kept without food for a few days, marked alteration occurs in their milk-fat composition (Smith and Dastur, Biochem. J. 1927, 2, 1868). The lower saturated acids, a large proportion of butyric acid, are much reduced, and the percentage in the oleic acid content takes a very large increase. The composition of normal cow depot-fat much more than a butter-fat. Similar suppression of the lower acids, and augmentation of the oleic acid content, has been observed in cows suffering from ketosis (Shaw

*et al.*, J. Dairy Sci. 1941, 24, 502; 1942, 25, 909).

Like depot fats, the composition of cow milk-fats may be influenced as the result of fats assimilated in the feed of the cows. Fats rich in oleo-glycerides, such as groundnut, Unseed, or rape oils, when fed to cows cause an increase in the oleic acid content of the milk fat compensated for by general adjustments in the proportions of the saturated acids; as a rule, however, the content of butyric and lower saturated acids is not drastically reduced. A curious feature is that the linoleic and linolenic acids present in such fatty oils do not appear in the butter fat; the milk fat of cows receiving Unseed oil in their diet, although much richer than normal in oleic acid, contained only traces of seed-fat linoleic acid and no detectable linolenic acid, whilst that of cows receiving rape oil also contained only traces of seed-fat linoleic acid, although minor amounts of erucic glycerides were found in the milk fat. The highly unsaturated acids of the C<sub>20</sub> and C<sub>22</sub> series present in cod-liver oil pass, however, to some extent into the butter fat of cows which have received cod-liver oil as part of their diet, and apparently these highly-unsaturated acids affect the normal metabolism of the mammary gland, for the butyric and other lower saturated acids are reduced to about half their normal proportions and the oleo-glycerides are much increased above the normal figure, so that the effect on the milk fat of cod-liver oil fed to the cow is similar to that produced by inanition or ketosis (Hilditch and Thompson, Biochem. J. 1936, 30, 677). When cows receive coconut or palm-kernel oil as dietary fats, the content of lauric and myristic acids in the milk fats is increased, lauro-myristins from the nut oils evidently passing to some extent into the milk fat.

The component glycerides of a typical butter-fat from cows on summer pasture have been given approximately by Hilditch and Paul (J.S.C.I. 1940, 59, 138). In molar percentages, monopalmito-glycerides form about 70%, and dipalmito-glycerides about 7%, of the butter fat; in other words, the distribution of the palmitic acid is very similar to that in ox depot-fats (c/. Table XXI, p. 30). The monopalmito-glycerides included:

	% of whole fat.
Palmito-mono-C <sub>4-14</sub> -bleins	22.30
Palmito-stearo-oleins	17.8
Palmito-diolein	17.4
Di-C <sub>4-14</sub> -palmitins	6
Palmito-mono-C <sub>4-14</sub> -stearin	9
Palmitodistearin	1

The dipalmito-glycerides included oleodipalmitin ca. 5%, and monosaturated dipalmitins ca. 2%. The rest of the fat, containing no palmitic glycerides, was made up approximately of about 8% stearo-olein, 12% of mono-C<sub>4-14</sub>-oleostearins, and 4% of di-C<sub>4-14</sub>-oleins. The distribution of the butyric and other lower saturated ("C<sub>4-14</sub>") groups in the glycerides is thus very widespread, and these groups appear to replace part of the oleic and stearic groups which are found in the mixed glycerides of the corresponding depot fats. The extensive distribution in more than half of the milk-fat

glycerides of the short-chain acyl group B in molecules which also contain two (or, less frequently, one) oleic, palmitic, or stearic groups, coupled with the simultaneous presence of mixed glycerides of oleic, palmitic, and stearic acids in the other half of the fat, probably confers on cow butter-fat its characteristic texture and "spreadability."

## MARINE-ANIMAL FATS.

## I. FISH (LIVER OR BODY) OILS (v. Vol. III, 244c-250c; V, 226d-235d).

The peculiar and characteristic occurrence in marine-animal fats of a wide range of unsaturated acids, chiefly of the C<sub>18</sub>, C<sub>19</sub>, C<sub>20</sub>, and C<sub>21</sub> series, with high polyethenoid unsaturation in the members of highest carbon content, leads to properties which have given some of the fish oils specific industrial applications. In addition,

certain of the liver and intestinal oils of marine animals are comparatively rich (some very rich) in vitamin B<sub>12</sub> and -D and hence have become important sources of these vitamins.

## (i) Liver Oils.

Cod-liver Oil (v. COD-LIVER OIL, Vol. III, 244c; IV, 591b) is the most common of the industrial fish-liver oils; it was of course used medicinally for many years before its importance as a source of vitamins A and -D was understood. Liver oils from other fish of the cod or Gadoid family, especially coalfish or saithe, and sometimes ling and hake, are included with cod livers in the production of the medicinal oil; so long as the oils are of £ collar vitamin contents to cod-liver oil the product is equal in value to "medicinal cod-liver oil" irrespective of the particular species of the family from which it has been produced.

TABLE XXIII.—CHIEF COMPONENT ACIDS OF FISH-LIVER AND BODY FATS.

Fish.	Fat content, %	Flit iodine value.	Unsaturation, %	Chief component acids.								
				Saturated.			Unsaturated.					
				C <sub>14</sub>	C <sub>16</sub>	C <sub>18</sub>	C <sub>18</sub>	C <sub>19</sub>	C <sub>20</sub>	C <sub>21</sub>	C <sub>22</sub>	C <sub>24</sub>
(I) <i>Mm</i> Oils.												
Cod . . .	40-65	165-170	0.8-1	3-6	8-11	0-1	<b>10-ia</b> (-2)	25-30 (-3)	<b>25-30</b> (-6 to -8)	10-18 (-7 to -8)	—	
Coalfish . .	40-60	155-170	0.7-1	0	2-13	Traces	10-15 (-2)	20-31 (-3)	24-26 (-5)	10-16 (-7)	—	
Unk . . .	ea. 70	UO-150	1.1	5	13	1	13 C-2	32 C-3	24 (-0)	12 (-7)	—	
Hake . . .	ca. 50	150-160	1.3	7	13	—	17 (-2)	18 (-3)	31 (-5)	14 (-7)	—	
Halibut . .	ca. 20	160-165	0.6	4	1.2	1	19 (-2)	34 (-2)	14 (-5.5)	13 (-7.5)	—	
Tunny . . .	20-25	155-170	1.8	—	18	9	3 (-2.5)	24 (-2*1)	<b>18</b> (-5.5)	18 (-7.4)	—	
Skate . . .	at. 40	180-190	0.3	4	<b>u,</b>	—	10 (-2)	20 (-3.3)	33 (-7.3)	11 (-9.5)	—	
Dogfish . .	40-50	NO . . .	10	0	10	3	0 (-2)	25 (-2.3)	20 (-3.3)	12 (-4)	8 (-2)	
Batfish . .	ea. 40	110-130	37*	—	8	7	3 (-2)	51 (-2.2)	20 C-2.9	8 (-3.5)	2 (-7)	
Basking shark	ca. 50	<b>L7&amp;-190</b>	50 -SOt	1	14	4	4 (-2)	<b>28</b> (-2)	10 (-2)	20 (-21)	10 (-2)	
(II) <i>Itt</i> Oil*.												
Herring . . .	8-20	1,40-170	1-2	7-8	13-10	Traces	5-7 (-2.6 to -3.0)	16-22 (-2.9 to -4.8)	27-30 (-4 to -5)	20-29 I (-4 to -5)	—	
Sardine . . .	10-18	160-190	0.5-1.5	6	10	2	13 (-2)	24 (-2)	28 (-5)	19 (-5)	—	
Pilchard . .	10-18	150	1	5	14	3	12 (-2)	18 (-3.3)	IS C-4.1	14 (-8.5)	15 (10.0)	
Menhaden . .	10-16	160-180	0.6-1.6	6	16	1	15 (-2)	30 (-4)	19 <b>C-10</b>	12 (-10)	—	
Salmon . . .	10-14	130-160	1	4-5	11-15	1-2	<b>B-1C</b> (-2)	20-29 C-2.7	ta 21. (-6)	16-21 (-6.5)	—	

\* Chiefly lauryl, etc., alcohol

t Chiefly squalene with minor amounts of batyl, etc., alcohols.

Other liver oils are now known which are very, much richer in one or both of the fat-soluble vitamins than cod-liver oil. In spite of the facts that the fish in question may be less abundant than cod, or that their livers have lower contents of fatty oil, the extremely high potency of the oils<sup>1</sup> renders them technically valuable. Halibut-liver oil, for example, is much in demand as a source of vitamins A and D for pharmaceutical preparations, and this is also the case to some extent with the liver oil of the tunny-fish, which is fairly abundant in the Mediterranean and parts of the Atlantic. A few species of shark, especially the soupfin shark, also yield vitamin-rich liver oils which are technical sources of concentrates of vitamins A and D.

The component acids of most of the fish-liver oils mentioned above (see Table XXIII) contain as a rule about 20-30% each of unsaturated acids of the C<sub>16</sub> and C<sub>20</sub> series, with 15-20% of the C<sub>18</sub> and 1-5% of the C<sub>22</sub> group; saturated acids, palmitic, form from 10 to 20% of the total fatty acids. The mean unsaturation of each group of acids (conveniently expressed as the fractional number of atoms of hydrogen short of complete saturation in the molecule, e.g. -2.0 H signifying monoethenoid) increases with rising molecular weights of the homologous groups: C<sub>16</sub>, -2.0 H; C<sub>18</sub>, -2.5 to -3.0 H; C<sub>20</sub>, -5.0 to -6.0 H; and C<sub>22</sub>, -7.0 to -8.0 H. Diethenoid unsaturation is very small, and each group of acids includes monoethenoid along with tetra-, penta- and hexaethenoid acids (cf. p. 13d).

An tholasmobranch group of fish, liver oils of the dog-fish and skate group may be found amongst technical oils listed as "Sod oil," but have no value as vitamin-containing oils. As already mentioned, soupfin and a few other shark-liver oils are rich in vitamins A and D; some other species of the smaller sharks, and also rays, contain liver oils with variable and often high content of the hydrocarbon squalene and, in some cases, of the glycerol mono-fatty alcohol ethers known as batyl, amyl, and selachyl alcohols. The latter oils are not yet available technically to any large extent. As explained earlier (p. 66) the oil of the portulacoid of the component acids of tholasmobranch fish-liver oils are related to the content of squalene and batyl, etc., alcohols. Oils relatively rich in these "unsaponifiable" components are less unsaturated than the rest of fish-liver oils; examples of the component acids of the liver oils of the skate, dogfish, ratfish, and some shark species will be found in Table XXIII.

#### (1) BONY OILS.

The flesh of some species of fish is fairly rich in fat. Technical fish oils are extracted from the flesh of herring and several related fish (sardine, pilchard, menhaden) and of salmon from the Pacific coast of North America. The oils from all these fish are of similar general character to cod-liver oil, but usually contain higher proportions of unsaturated C<sub>16</sub> and C<sub>18</sub> acids than the latter. A few of the component acids of herring oil

belong to these groups. Hydrogenated herring and similar oils may replace hydrogenated whale-oil in the manufacture of margarine or soap, but for the latter purpose the high proportion of C<sub>16</sub> and C<sub>22</sub> acids (which on hydrogenation are finally converted into arachidic or behenic acids) causes the lathering power of the soaps to be somewhat less than that of soaps from hydrogenated whale oil.

The chief component acids of the above fish-liver and body oils, with their average ranges of unsaturation, are illustrated in Table XXIII.

## II. FATS OF AQUATIC MAMMALS.

The oils from the blubber of whales belonging to the family *Balaenidae*, including Greenland, finner, hump-backed, and other whales, have become of great technical interest since the introduction of fat hydrogenation on a large scale.

Whale-blubber Oil (see WHALE OIL, Vol. V, 2296-2306) was, until about 1910, produced by somewhat crude methods and was a low-priced oil used mainly, like the technical fish-oils (v. supra), in the leather industry. When fat hydrogenation became an industrial process, whale oil became the favourite raw material for hardening owing to its low price and to the circumstance that, in spite of a general resemblance in composition to the fish oils, its content of acids of the C<sub>20</sub> and C<sub>22</sub> series is not so great as to cause the soap-making properties of hardened whale-oil to be very different from those of tallow.

The component acids of the Northern and Southern types of whale oil show characteristic differences. The Arctic varieties are more unsaturated and contain more of the C<sub>20</sub> and C<sub>22</sub> acids than the Antarctic oils; the former thus resemble more nearly the ordinary marine fish-oils, whilst the Antarctic-whale oils are in composition intermediate in some respects between marine and fresh-water fish oils. Arctic-whale oils usually have iodine values of 140-150 and their component acids may include (approximately): myristic 4-6, palmitic 10-12, stearic 3, unsaturated C<sub>16</sub> 15-18, C<sub>18</sub> 30-35, C<sub>20</sub> 18-20, and C<sub>22</sub> 10-12%. Antarctic-whale oils, on the other hand, have lower iodine values (110-120), their component acids being usually: myristic 6-8, palmitic 18-20, stearic 1-2, unsaturated C<sub>16</sub> 11-13, C<sub>18</sub> about 40, C<sub>20</sub> 12-14, and C<sub>22</sub> 6-7%. The average unsaturation of the unsaturated acids is of the same order in both types, namely, C<sub>16</sub>, almost wholly monoethenoid, C<sub>18</sub>, -2.5 to -3.0; C<sub>20</sub>, -5.5 to -7.0; and C<sub>22</sub>, -8.0 to -10.0 hydrogen atoms per molecule. Nearly 90% of the unsaturated C<sub>18</sub> acids of whale oil is oleic acid, the rest being mainly octadecatetraenic acids, C<sub>18</sub>H<sub>32</sub>O<sub>2</sub>.

Whale-liver Oil forms only about 3-4% of the organ, but is sometimes worked up separately on account of its high content of vitamin-A. The fat appears to be very similar in composition to the blubber oil since, according to Klenx\* (Hvalradets Skr. 1935, No. 11, 6) the component acids include 18% of highly unsaturated and 24% of "solid" (i.e., saturated and higher monoethenoid) acids.



*j* It may also be mentioned again that *whale-milk-fat* is closely similar to the blubber fat, its component acids being made up of myristic 8, palmitic 17, stearic 2, unsaturated  $C_{16}$  6,  $C_{18}$  27,  $C_{20}$  26, and  $C_{22}$  13%; the mean unsaturation of the higher acids ( $C_{18}$  —3.3,  $C_{20}$  —8.5, and  $C_{22}$  —11) of the milk fat is, however, greater than that of the body fat (Klem, *op. cit.*).

Seal-blubber Oil has been used for various purposes (amongst others as an illuminant) for at least as long as whale oil, but its production has not increased by any means to an extent similar to that of whale oil, in spite of the fact that seal oil of excellent quality is obtainable from time to time. Its iodine value is usually intermediate between those of Arctic- and Antarctic-whale oils and, according to a partial analysis by Williams and Makhrov (Schrift. Zent. Forsch. Lebensm. (U.S.S.R.), 1935, 4, 157), it contains the following groups of acids: saturated (mainly palmitic) 18, liquid monoethenoid (presumably oleic and hexadecenoic) 61, solid monoethenoid (probably  $C_{20}$ ) 7, and highly unsaturated acids 14%. Burke and Jasperson (J.S.C.1.1944,63,245) record myristic 4.9, palmitic 11.4, stearic 1.8, arachidic 0.5, with unsaturated  $C_{14}$  1.3 (-2.0 H),  $C_{16}$  13.1 (-2.0 H),  $C_{18}$  39% (-2.5 H),  $C_{20}$  23.2 (-4.9 H), and  $C_{22}$  acids 4.7% (wt.) (-5.0 H).

The component glycerides of several fish and whale oils have been investigated from a semi-quantitative standpoint. All the investigations in this field point to the conclusion that the fish and whale oils, with their complex mixtures of component acids, are made up of complicated mixtures of mixed triglycerides. In any one triglyceride molecule of a fish or whale oil there are probably very frequently three different acyl groups; "even distribution" of fatty acids amongst the glycerol molecules is pronounced, and coupled with the large number of component acids, leads to a most heterogeneous mixture of, in most cases, treble mixed triglycerides.

An Antarctic-whale oil was partly resolved into simpler mixtures of its components by crystallisation from acetone at progressively low temperatures down to  $-30^{\circ}$  (Hilditch and Maddison, *ibid.* 1942, 61, 169). 86% of the triglycerides contained one unsaturated  $C_{18}$  group (mainly oleic), and two of these groups were present in a further 8% of the oil; oleo-di-unsaturated ( $C_{14}$ ,  $C_{16}$ ,  $C_{20}$ ,  $C_{22}$ ) glycerides formed 12, oleo-saturated-unsaturated ( $C_{14}$ ,  $C_{16}$ ,  $C_{20}$ ,  $C_{22}$ ) glycerides 66, and oleomyristopalmitins 8% of the whale oil. About half of the whale oil contained no acid higher than the  $C_{18}$  series, and about one-third contained one or two groups per triglyceride molecule of the highly unsaturated  $C_{20}$  or  $C_{22}$  acids. One consequence of the general glyceride structure of whale oil is that, after hydrogenation to the same iodine value as that of a beef fallow, it contains fully-saturated components similar in proportion and composition to those of the latter, although of course the constituents of the mixed saturated-unsaturated glycerides in the rest of the fat are qualitatively dissimilar from the corresponding glycerides of a beef fat.

Sperm-whale Oil (*v.* Vol. V, 230a), from the

blubber or head cavity of the sperm, t'achelot, or bottlenose whales, differs entirely in composition from the *Balsenic* type of whale oil, and consists largely of esters of higher fatty alcohols with higher fatty acids in addition to a certain proportion of triglycerides. Consequently, although liquid at the ordinary temperature, sperm-whale oils deposit on cooling a solid wax (*see* SPERMACETI) which is mainly composed of cetyl palmitate, myristate, and laurate. The industrial process of obtaining spermaceti, namely, chilling the oil at  $0^{\circ}$  for some weeks and subsequently pressing it at  $0^{\circ}$ , followed by repressing the solid residue at about  $15^{\circ}$ , leads to a yield of about 10-15% of spermaceti from the original oil, since much of the solid wax-esters remain in solution in the liquid constituents. Complete hydrogenation of sperm oil furnishes a wax of higher melting-point ( $48\text{--}52^{\circ}$ ) than the natural spermaceti, as the oleyl esters in the original oil being converted into octadecyl esters of palmitic, stearic, arachidic acids, etc.

The oils from the head cavity and the subcutaneous tissues of the sperm whale differ considerably in composition. *Sperm-head oil* contains about 75% of wax esters and 25% of glycerides, whereas *sperm-blubber oil* has as a rule about 65% of wax esters and 35% of glycerides. The fatty alcohols present as wax esters in the *head oil* comprise nearly 50% of cetyl alcohol  $C_{16}H_{37}(OH)$ , 10-12% each of octadecyl alcohol,  $C_{18}H_{37}(OH)$  and hexadecyl alcohol  $C_{16}H_{33}(OH)$ , about 25% of oleyl alcohol,  $C_{18}H_{35}(OH)$ , and a small amount of eicosenyl alcohol,  $C_{20}H_{39}(OH)$ ; those in the blubber oil are made up of less of saturated alcohols (15% cetyl and some octadecyl), about 65% of oleyl alcohol, and about 10% each of hexadecyl alcohol and of alcohols of the  $C_{20}$  group. The unsaturation of the acids in sperm oil is almost confined to monoethenoid compounds, and in this respect and in the presence of more acids of lower molecular weight and less acids of the  $C_{20}$  and  $C_{22}$  groups the sperm-oil fatty acids are sharply differentiated from those of ordinary whale oil. The component acids of *sperm-head oil* include: capric 3, lauric 16, myristic 14, palmitic 8, stearic 2, dodecenoic 4, tetradecenoic 14, hexadecenoic 15, oleic 17, and gadoleic 7%, whilst those of *sperm-blubber oil* are: lauric 1, myristic 5, palmitic 7, tetradecenoic 4, hexadecenoic 26, oleic 37, unsaturated  $C_{20}$  19 (-2.5 H), and unsaturated  $C_{22}$  1% (-4 H). The 30% of fully saturated esters and glycerides in the *head oil* (the blubber oil contains only minor amounts of fully saturated compounds) is made up of alcohols and acids of lower average molecular weight than that of the whale oil.

**Dolphin and Porpoise Oils.**—Marine mammals belonging to the family Delphinidae (dolphin, porpoise, white whale) contain deposits of fat in their blubber and also in cavities in the head and jaw. All these types of fat are unique in containing notable proportions of combined tfovaleric acid, which is most abundant in the jaw oils and least abundant in the body oils. This tfovaleric acid is in combination with the usual higher fatty acids in the form of mixed glycerides and no tri-ovalerin has been detected.



Moreover, isovaleric acid is absent from the liver/heart, and other organ fats of the porpoise, and is only present in traces in the fat of the porpoise, *Loxosteptes* (Lovern *op. cit.* Biochem. J. 1934, 28, 394). Thus, although isovaleric acid is absent from the liver and other organ fats, its mode of

association with the higher fatty acids in the mixed depot-fat glycerides is exactly similar to the manner in which the latter are themselves assembled in other fats as mixed glycerides. Lovern (*op. cit.*) gives the component acids for dolphin and porpoise fats shown in Table XXIV.

TABLE XXIV.—COMPONENT ACIDS (% WT.) OF DOLPHIN AND PORPOISE FATS.

	Dolphin.		Porpoise.		
	Blubber, %.	Head, %.	Jobber, %.	Head, %.	Jaw, %.
Saturated acids:					
Valeric	3.2	13.9	13.6	20.8	25.3
Lauric	1.0	2.4	3.5	4.1	4.6
Myristic	7.2	12.6	12.1	15.8	28.3
Stearic	8.6	11.6	4.7	7.5	4.1
Oleic	0.8	0.4	—	0.2	—
Unsaturated acids:					
Oleic	—	—	Traces	—	Traces
Linoleic	—	2.7	4.7	4.6	3.2
Arachidic	—	25.4	27.2	20.8	20.3
Behenic	24.1	15.8 (-2.8)	16.7 (-2.8)	15.2 (-2.6)	9.3 (-2.6)
Lignoceric	18.6 (-6.5)	12.7 (-5.5)	10.5 (-4.8)	9.4 (-4.5)	4.9 (-4.9)
Myristic	5.9 (-3.6)	2.6 (-7.2)	7.0 (-4.9)	1.6 (-4.7)	—

The blubber fats contain 2.1%, and the head larger amounts (up to 10% or more) of higher fatty alcohols combined with the fatty acids as wax esters.

TECHNICAL PREPARATION OF FATS AND FATTY OILS.

EXTRACTION OF FATS.

The methods of preparing fats and fatty oils for human use date back as far as the history of the human race. The crudest methods of rendering oils from seeds and fruits, which probably still prevail in certain backward tropical regions, consist in allowing the broken fruits to melt by the heat of the sun, when the exuding oil runs off and is collected. The native production of palm oil, & also of coconut, oil by boiling the copra with water, are later methods of these primitive procedures, and to the methods practised on the modern scale for rendering animal fats and oils from the tissue, as is done in the technical production of tallows, lards, cod-liver oil, and whale oil.

Again, the preparation of fatty oils from small seeds, such as flax or tallow, was practised in ancient times by crushing the seeds and grinding them between stones (as is still done in some parts of India). A development of this lay in breaking the seeds and pulverising them under a mill, and bating the meal in an open pan, and agitating it in a wedge-press, the wedges being driven home by hammers. A further step consisted in employing stone mills on the principle of a mortar and pestle in which a bullock or horse was used to provide the motive power in the grinding. These processes represent the initial stages from which have developed the modern procedures of expression in hydraulic presses by oil-mills. A further modern alteration of the procedure of comparatively recent

At the present day it is recognised that fats as produced in the mature living tissue, vegetable or animal, are in a condition of maximum purity and freshness, and that any changes which may set in during their isolation for technical use must be of a retrogressive or deteriorating character. Consequently the first aim, during collection, storage, transport or preliminary preparation of the fatty material for extraction of its contained fat, must be to guard against deterioration of the latter, either by biological (enzyme) or merely chemical changes, and especially in respect of partial hydrolysis or oxidation of the fat. The subsequent fat extraction is effected by one or more of the following methods: expression by the application of pressure to the cold or warmed comminuted tissue; extraction of the latter by suitable organic solvents; separation of the fat by heating the comminuted tissues with water, either at the ordinary pressure or in autoclaves ("rendering").

The current procedures for dealing with various types of fat-containing produce are briefly reviewed here, but for a more complete description of the plant involved the reader should consult one or other of the more comprehensive monographs in which the subject is treated in full detail (c/. Bibliography, at end of article).

Extraction of Fats from Vegetable Pulp (Fruit Flesh).—The only fats at present produced on a large scale from the flesh of fruits are palm and olive oils. This type of raw material is obviously more easily damaged by retrogressive changes than hard seeds or nut kernels, and great care is essential in gathering and handling the fruit. The fruits should be as exactly ripe as possible, and bruising of the fruit during collection or transport must be avoided. In modern practice palm and olive oils are extracted at factories located comparatively close to the plantations where the fruit is grown. On arrival at the factory, the palm fruit is sterilised by heating under slight

steam-pressure and then either passed through a machine in which the pericarp is sliced and the palm nuts removed, or into a digester which separates the pulp from the nuts. The fruit pulp is then either fed into a steam-jacketed hydraulic press to remove the oil, or into a centrifugal extractor fitted so that steam can be injected into the mash during centrifuging. Over 85% of the palm oil present is obtained, after settling from entrained mucilage, as an oil with less than 3.5% of the fatty acid, and is exported in steel drums or in vessels fitted with large oil-tanks.

Modern production of olive oil consists in breaking up the fruits in stone edge-running mills and treating the resulting pulp in hydraulic cage presses, or in continuous presses of the expeller type (*v. infra*), or by centrifugal separation. In modern practice 60-70% of the olive oil is recovered by these processes as first-grade edible oil, the extracted pulp or marc yielding a further amount of lower-grade olive oil on extraction with solvent.

**Extraction of Fats from Vegetable Nuts and Seeds.**—In most cases seeds and kernels are worked up for their fat in factories far distant from where they are collected; palm kernels and groundnuts from West Africa, for example, are extracted in Liverpool, Hull, Marseilles, or Hamburg; Egyptian and Indian cottonseed and other seeds in the English factories and elsewhere, etc. Several points connected with the transport and storage of the seed are therefore important.

Bulky nuts, *e.g.*, those of the oil palm and other tropical trees, in which the shell weighs as much as or more than the kernel, are de-integrated (shelled) before transport in order not to waste cargo space. Special disintegrating machines, designed to break the shell without fracturing the kernel, are employed at the place of collection of the seed, or near to where it is shipped, for this purpose. Seeds and nuts with smaller and more fragile husks, such as the groundnut, may or may not be similarly treated, the term decortication being used for the shelling of seeds of this type. The endosperm of the coconut forms a special case, since it is removed from the shells and dried in fragments to a fat-content of about 65% by exposure to sun or in heated air in kilns, the product ("copra") being then packed for shipment. Small seeds, such as linseed, rape seed, sunflower seed, and soyabean, are transported without decortication.

The nut or seed, if ruptured or punctured, is susceptible to retrogressive changes in its fat and other constituents; the fat is then comparatively readily hydrolysed in presence of moisture by lipolytic enzymes, and may also undergo other enzymic decompositions, notably oxidation. To prevent development of rancidity in any form, therefore, the seeds must be sound, as free from superficial damage as possible, and kept free from moisture during storage. Modern practice consists in storing seed in tall, narrow, vertical, well-ventilated bins (silos); if the temperature in a compartment rises the seed is transferred to a fresh bin in order to dissipate the heat and check the development of hydrolytic

When the seed is required for extraction, it is first cleaned from any adherent fibre, mineral matter, etc., by machinery, and passed over a magnetic separator to remove any particles of iron or steel. Next, if the husks are to be removed, the seed may be decorticated at this stage by passage through rollers with sharp grooves or cutting blades which can fracture the shells without cutting or bruising the kernels or "meats"; or, if not, it may have any plant fibrous hairs (*e.g.*, in cottonseed) removed in a delinting machine. The seeds are then ready for grinding into meal which is in a form suitable for extraction of the fat. The milling machinery employed consists of a series of rolls, through which the seed is fed and in which it is progressively cut into particles of the requisite fineness. The rolls are designed to function with a cutting rather than a crushing action, since it is not expedient at this point to cause expression of oil from the endosperm cells. The design and number of the rolls in the machine varies with the type of seed to be crushed; "reducing" machines with relatively coarse fluting are used for the earlier stages of milling the larger seeds, and "finishing" rolls which reduce the seeds to fine particles of meal complete the process. \*

**Extraction by Pressure.**—Seed meal to be extracted in either cage or expeller presses may be treated in the cold, but more frequently is expressed at a moderate temperature, often 50-60°, and in some cases 100-110°. For hot-pressing, the meal is first cooked in steam-jacketed vessels to the desired temperature. The ease with which seeds yield their fat during application of pressure depends on the moisture content as well as the temperature, and Skopin and others recommend the addition during cooking of a definite proportion of water, the optimum moisture content and temperature being variable but specific for each kind of seed.

Large hydraulic processes of various types are used for seed-expression. Broadly speaking these are of two classes: the "open" type in which the meal is placed in stout canvas bags between horizontal iron plates, and the "closed" type in which the meal is filled direct on to a number of horizontal iron plates resting within a closed vertical casing perforated with minute holes through which the liquid fat exudes. Pressure is applied usually in two stages, first at 1-2 tons per sq. in., and subsequently at 1.5-2 tons per sq. in. (open press) or 3-4 tons per sq. in. (closed press). The fat content of the meal is thus reduced finally to a desired figure of between 5 and 10%, depending on the type of oil cake (cattle feed) for which it is required (*v. infra*). The capital cost of a hydraulic pressure plant of these types is large and the process is therefore carried on in factories where the output of oil is on a large scale; expressed oils are frequently preferred to solvent-extracted oils, especially for the edible-fat trade, whilst the seed cake produced has an oil content which adds to its value as a cattle food.

**Expeller presses** are another form of fat expression plant which has been developed subsequently to the hydraulic press. The seed meal is fed forward by a screw conveyor and pressed

through a narrow annulus between a conical head piece and a perforated cage; the action of the screw causes increasing pressure on the meal as it passes through the expeller. The expeller press thus works on the continuous principle, and has some advantages over the hydraulic press, especially where the output of the factory is relatively not large. It has also found favour in the larger factories, especially in America, and is frequently used in the expression of oil-rich seeds such as copra or groundnut to reduce the oil content to a stage at which the material can be more conveniently handled by hydraulic pressure or by solvent extraction. The expeller process is economical, but the oil produced may contain more mucilage than hydraulic-pressed oil, and usually requires filtration.

**Extraction by Solvent.**—Extraction of seed meals by organic solvents instead of by pressure has made considerable headway, the solvents used being mainly light petroleum f.c.p. b.p. 60-80°C or V.P. 8(V-10) but also to some extent tricloroethylene, which has the merit of non-inflammability. The seed meal is left somewhat coarser for solvent than for pressure extraction, and is charged in layers separated by fibre mats or other horizontal partitions in cylindrical vessels headed with reflux condensers. Several of the vessels may be connected in series, and operated on the counter-current principle, so that fresh meal is exposed to solvent which is already charged with fat, whilst the almost-extracted meal receives a charge of fresh solvent. The solvent is usually employed first cold and later at a somewhat higher temperature. The fat-charged solvent is finally passed through a double still system, in which the bulk of the solvent is first evaporated and recovered, the fatty oil then passing down the plate of a column at the base of which a current of steam enters and, during its upward passage, removes the last traces of solvent from the fat. The residual extracted meal contains only 1-2% of oil and is freed from solvent by steaming, dried, and mixed in compound cattle foods or as fertiliser. Solvent extraction thus yields approximately the full oil-content of the seed; it is economical in use of solvent, the "make-up" of which should not exceed 3-6 gallons of spirit per ton of oil extracted.

**Residual Oilseed Cakes.**—Fully extracted oil-cake has in any case considerable value as a fertiliser or artificial manure, since it contains notable amounts of protein nitrogen, phosphate and potash. Solvent-extracted fish (herring, etc.) meal is frequently used in this way, but extracted seed-cakes are usually so disposed of only when, by reason of toxicity, they are inapplicable as cattle foods (e.g., castor seed, niowrah seed and some others). If a residual oilseed cake is suitable for use as cattle food, its market value is much greater than when sold merely as a fertiliser, and most of the oil in Europe and America goes into "straight" or "compound" cattle-foods. The oil from expressed seeds which still contains 20% or so of fatty oil is sold to the dairy farmers as "B.T.A. 87" and is sold to the dairy farmers as "B.T.A. 87" and is sold to the dairy farmers as "B.T.A. 87". That from solvent-ex-

tracted seeds is priced as a rule at about half that of expressed oil-cake, and is assessed mainly on the nitrogen content as an index of the protein content; extracted oil-cake is used, in admixture with molasses and starchy materials, to form "compound" cattle-cake. Cottonseed, linseed, groundnut, soya bean, palm kernel and other oilseed cakes are readily disposable in Europe and America as foodstuffs for farm cattle.

**Extraction of Fats from Animal Tissues.**—For the most part the treatment of animal fatty tissues consists in "rendering," i.e., heating the tissue, usually with water or steam, in order to rupture the fat cells and liberate the fat. The same general principles apply to the handling of animal as of vegetable tissues prior to fat extraction, namely, maintenance of the tissues in as clean and aseptic conditions as possible, the removal of the fat-containing material from adjacent non-fatty tissues, and its reduction where necessary by chopping or mincing to a state of division suitable for rendering. In animals such as the pig or ox, the adipose tissues are separated by hand, cleansed, and disintegrated by machinery. Whales are denuded of their blubber layers mechanically and the strips of tissue cut into smaller pieces by machines designed for the purpose. Fish livers, such as cod, are taken from the fish, washed mechanically or by hand, and are frequently rendered without cutting into smaller pieces. The precise mode of preparatory treatment thus varies with the raw material from which the fat is to be obtained, as also do the extraction procedures which are subsequently operated. The main processes used for extracting fat from animal tissues will next be briefly discussed.

**Rendering of Animal Fats in the Absence of Water.**—Perinephric and back or rump adipose tissues of cattle and pigs contain 90% or more of fat, much of which is released from the cells when the tissues are heated to only a moderate temperature. The best edible qualities of beef tallow ("premier jus") and lard ("neutral lard") are obtained by this means. The plant employed consists of iron vessels lined with tin or enamel and fitted with mechanical stirring gear and a closed steam coil for applying heat, and closed with a light lid to exclude atmospheric dust. The vessel is charged with the milled or shredded tissue, heated to the extract temperature appropriate to the material (usually between 40° and 60°), and the contents gently agitated. The fat gradually escapes and floats to the top, from which, when the process is complete and the contents of the vessel have been allowed to settle, it is removed by a skimmer-pipe.

A modification of this "dry-rendering" process, used for the production of inedible fats, consists in the use of a steam-jacketed closed vessel, capable of withstanding moderate pressure, in which the minced tissues are heated until a pressure of 30-40 lb. per sq. in. is attained by the steam evaporated from the moisture in the tissues. Mechanical agitation is usually provided to stir the material and to scrape off scraps which may adhere to the walls of

the vessel. Extraction is fairly complete at the temperature attained (12ft-130°), and the rendered mass is drained, the residual tissue being further extracted if desired by passage through an expeller press. Fat of good soap-making quality is thus obtained, but its slightly darker colour (compared with that of fat rendered at lower temperatures) restricts its use for edible purposes. The finally extracted powdered tissues are rich in protein and are suitable for poultry and similar foods.

*Rendering of Animal Fats in Presence of Water*  
(i) *up to 100°*.—Vessels (not necessarily tinned) similar to those used for "dry-rendering" at 40-60° may be employed, an open as well as a closed steam-coil being fitted in the present case. The tissue is placed, with about an equal weight of water, in the vessel and heating is effected by steam in the closed coils or by admission of open steam, the process being carried out at 40-60° if the highest edible qualities of fat are being produced, or at higher temperatures (up to 100°) if a higher yield of fat (of somewhat lower quality) is desired. The residual tissues are usually autoclaved (*v. infra*) to remove the remaining fat.

This process, at 40-60°, is used to produce the best qualities of edible ("neutral" lard), whilst rendering with water at or up to 100° yields somewhat lower grades of edible lards and tallows. The latter process also furnishes the highest qualities of fish-liver oils (notably cod-liver oil) and whale oil (no. 0-1 grade).

*Rendering of Animal Fats in Presence of Water*  
(ii) *in Autoclaves above 100°*.—Higher yields of fat, but usually of lower quality, are obtained by carrying out the preceding process in closed vessels provided with open steam coils, the contents being treated at pressures up to 150 lb. per sq. in. The fat charge (either fresh tissue or residual tissue from one of the above processes) is mixed with a small proportion of water and heated with open steam for several hours, usually at about 60-90 lb. per sq. in. pressure. Practically all the fat present is dislodged from the tissue and is drawn off after the pressure has been released and the contents of the vessel settled.

The autoclave or digester process is used to produce the following, amongst other, technical fats:

The lowest edible grades\* of lards—"leaf" lard from the residual tissues left after the "neutral" lard has been extracted, and "prime steam" lard from tissues of the pig other than the flare (perinephric) and back.

Ox and sheep tallows for soap and candle manufacture from all parts of the animals, other than the skin, bones, and intestines.

Skin greases from the skins and adjacent flesh of pigs, oxen, and sheep; neat's-foot oil from hooves of cattle; bone (and intestinal) fats of pigs, oxen, and sheep (bone fat, bone greases, brown greaifes; *v. Vol. VI, 134c*).

Lower grades of fish and whale oils, including 2 grade whale-oil from the residues of the blubber after rendering the no. 0-1 grade oil, no. 3 grade whale-oil from whale flesh other than blubber, and no. 4 grade whale-oil from the bone and intestines of the whale (a very low

grade, dark oil containing up to 30% of free fatty acid).

*Extraction by pressure* (either in hydraulic or expeller presses) is sometimes employed in the manufacture of a few animal fats, including those of small fish (herrings, sardines, etc.) the flesh of which is rich in fat.

It may be mentioned here that submission of edible tallows ("premier jus") and lards to pressure in the cold is employed to separate these fats into others of equal edible quality but different physical consistency—respectively harder (oleostearin, lard stearin) or softer (oleo oil, lard oil).

*Solvent extraction* is also occasionally met with in the production of animal fats; for example, in the isolation of greases from skins or bones, and of low-grade fish oils from herring and similar fish residues.

#### REFINING OF FATS.

All fats require some form, and usually several forms, of refining before they are fit for technical use, whether this is to be as edible fats, in soaps, candles, or as vehicles for paints, etc. The impurities which may require to be eliminated may be classified as (i) suspended matter, mucilaginous, colloidal, or resinous, carried mechanically with the fat during its extraction; (ii) free fatty acids produced from the natural fat prior to or during extraction; (iii) natural colouring matters extracted with and dissolved in the fat; and (iv) semi-volatile compounds extracted with and dissolved in the fat, which thereby acquires an undesired odour or flavour. Only a few fats, notably the highest edible qualities of lard and "premier jus", olive oil, cacao butter and perhaps one or two ethers, is the refining treatment confined to the removal of the first-named group of these impurities (mucilaginous or other non-fatty matter in suspension in the fatty oil). The rest may require removal of free fatty acids, of coloured organic impurities, and (for edible purposes) of traces of impurities conferring odour and flavour, before they are in a suitable condition for final use. A brief account of the chief methods employed in the removal of each of these various types of impurity will here be given; in general, however, it may be said that the refining of each individual fat presents special features, and that the technical procedure to be adopted varies correspondingly and to some extent must be determined by experimental trial in each case.

#### 'Removal of Suspended Non-fatty Matter.'

Removal of comparatively coarse mucilage, fragments of non-fatty tissue, etc., carried mechanically into the crude fat during extraction is usually effected by maintaining the fat in the liquid state in large tanks for several days, when the coarser impurities settle to the bottom, leaving clear, oil which can be drawn off or, if desired, filtered through a press.

When, as frequently happens, the fatty oil contains in suspension not only relatively coarse particles but also very finely divided or colloidal organic matter, it is preferable to settle the oil

after first injecting wet steam into it at 100° for a short time, or to boil it similarly with open steam in presence of salt (1 or 2 per cent, of salt on the fat treated). After settling for a few hours the lower layers of condensed water (brine) and oil-water emulsion are withdrawn. The emulsion and the aqueous layer (and still better the clarified fat as well) may be fed continuously through a centrifugal separator, leading respectively to less loss of oil in the emulsion and to a brighter and cleaner product as regards the settled fatty-oil layer.

In a few particular instances, notably Unseed oil, colloiddally dispersed material coagulates or "breaks" when the oil is heated to a specific temperature (usually between 200-240°); after heating, the oil is allowed to cool, when the coagulated compounds settle to the foot of the tank, leaving a paler and brighter product than the crude oil.

#### Removal of Free fatty Acid

The method most frequently adopted to neutralise free acidity in a fat is, naturally *alkali refining*, the fatty acids being subsequently washed away as soaps; frequently, especially with vegetable fats, coloured organic compounds (which often contain pteridic or other acidic groups) are simultaneously removed, either by combination with the alkali or by adsorption on the soaps formed during neutralisation of the oil. Alkali refining therefore as a rule improves, sometimes to a marked extent, the colour of the fatty oil and has the effect of bleaching it in addition to removing free fatty acid.

Technical methods of neutralisation are numerous and the choice is determined by the nature of the fat and its content of free fatty acid. Sodium carbonate, caustic soda, or lime may be employed to combine with the free acids present; continuous processes for alkali neutralisation have been devised; and removal of free fatty acid by steam distillation at high temperature and low pressure has received considerable attention in recent years.

Alkali Refining of fats is carried out in cylindrical tanks fitted with tapering or conical bases to facilitate settling and withdrawal of the resulting soap solutions. The plant is provided with open and closed steam coils, mechanical stirring gear and a skimmer pipe for withdrawal of oil from the upper layers of the contents of the vessel. The mode of operation varies with the nature of the crude fatty oil and of the alkaline reagent employed and, moreover, practice and skill are required in conducting the process so as to produce soap (or "scum," to use the technical term) with the maximum proportion of entrained fat.

Neutralisation by sodium carbonate (soda ash) preferred both because the reagent is cheaper

and because smaller losses of neutral fat result by use of soda ash than with caustic soda. Refining with soda ash is thus preferred in the case of high-quality fats which are naturally pale or slightly coloured, in the case of crude oil. The crude oil may be heated

to about 80°, pumped on to a concentrated solution of sodium carbonate (in slight excess of that necessary to neutralise the free acid present), and the mixture carefully heated with open steam for a short time; after addition of brine, if necessary, to break any undue emulsion, the oil is settled and the thick mass of "foots" drawn off at the base of the vessel. Alternatively, the mixture of fat and carbonate solution may be heated by closed coils until, by evaporation, the soaps become sufficiently dry to rise to the top of the oil in the form of a cake; in this case the oil is drawn off from the base of the vessel, and the loss of fat in the soap is often less than by the previous method. In both processes the neutralised fat is washed several times with hot water and settled in order to remove all traces of soap.

Neutralisation by caustic soda, is also much employed, and especially when there is more than about 5% of free fatty acid in the crude fat, or when the latter is more or less coloured. The procedure is similar to that just described, except that caustic soda solution (in strength which may lie between 20° and 100° Tw.) is gradually run into the warm oil whilst the latter is stirred and eventually brought nearly to 100° C. with steam. With pale-coloured fats of low acid content the caustic soda may be used in a quantity about 0.5% in excess of that necessary to neutralise the free fatty acid, but with crude fatty oils the colour of which can be reduced by alkali refining this excess may be increased to about 2% with beneficial results in regard to decolorisation. The oils which are most improved in colour during alkali refining include cottonseed oil, other dark vegetable oils such as rape, soya-bean, or Unseed oils, whale and fish oils. The loss of neutral fat in the "foots" is in general somewhat greater with caustic soda than with carbonate, and in any case this loss is greater the higher the proportion of free fatty acid in the oil. For fatty oils which contain more than 10% of free fatty acid it is best to effect neutralisation in several stages, removing not more than 5% of free fatty acid at a time. It is not usually economical to neutralise crude fats with a content of more than 25% of free fatty acids.

The yield of neutral fatty oil can be increased by gassing the soapy "foots," and also the subsequent wash-liquors, through continuously-operated centrifugal separators, when a further quantity of neutral fat is recovered and the centrifuged soap-stock may contain only 10-20% of fat. The fat-content of "foots" from alkali refining may otherwise range from about 35-70%, according to the procedure employed and the proportion of free fatty acid in the original crude fat.

From 1933 onwards processes for *continuous alkali neutralisation of fats* have been introduced, especially in the United States. Fatty oil and caustic soda solution, in closely regulated proportions, are fed into a mechanical mixer and passed through a tubular heater in which the oil-alkali emulsion is rapidly brought to about 90°, after which it enters centrifugal separators which deliver continuously the separated soap-stock and the neutralised oil, the latter being washed

with water in a continuous system and again separated by centrifuge. Owing to the short contact time (about 5 minutes) of fat and alkali, hydrolysis of neutral fat is minimised, whilst the loss of neutral fat in the soap-stock is also reduced in comparison with the other processes.

*Neutralisation by lime* is occasionally employed, in place of soda refining, to obtain a very high yield of neutral oil. The procedure is similar to that used in refining with sodium carbonate, but is best carried out in a closed vessel heated by closed steam coils. Lime in 1% excess of that necessary for exact neutralisation is mixed (in the form of a thick cream with water) with the heated oil, and the water present is subsequently removed by evaporation under reduced pressure; the calcium soaps are then in the form of an almost anhydrous granular suspension and can be removed from the neutral fat by passage through a filter press.

*Disposal of Alkali Soap-stock or "Foots"*—In certain instances the soap-stock is directly suitable for complete conversion into soaps of technical value and, in the larger modern installations in which fat refineries and soaperies are departments in the same factory, the soap-stocks can be passed to the soapery for complete saponification and utilisation in toilet or household soaps. This applies especially to soap-stocks from such fats as coconut, palm-kernel, groundnut, cottonseed, palm and other oils destined for edible use. Alternatively, the soap-stocks may be converted by boiling with dilute sulphuric acid into *acid oils*, which are sold to soap or candle makers. In the United States, cottonseed soap-stock as such is largely sold by the cottonseed oil refiners to soap manufacturers.

Soap-stock and "foot" from the more unsaturated fatty oils, such as linseed, soya-bean, or whale, are also used to a certain extent in the production of soft soaps. Many "acid oils" from alkali refining, especially from the more unsaturated fatty oils and also from other lower-grade fats, are too discoloured or too rancid to be used for soap, and must be further treated by distillation. In such cases the "acid oil" is completely hydrolysed to fatty acids (the liberated glycerol being separately recovered, v. GLYCERIN, Vol. VI, 40c-71o), and the latter are distilled at low pressure at about 250-300°. The distilled fatty acids, on chilling and pressing, yield acids liquid at the ordinary temperature ("oleines") and solid acids ("stearines," v. Vol. II, 263c).

It has also been proposed to reconvert "acid oils" into neutral fats by esterifying the free acids present with glycerol by heating at 180-250° under reduced pressure; it appears unlikely, however, that the quality of the fats so produced is adequate to make the procedure an economic success.

*Removal of Free Fatty Acids by Distillation Processes.*—Processes have been introduced for the direct removal of free fatty acids from crude fats by a process of steam distillation, notably by Wecker and Lurgi. The essential features are that a mist of finely divided water or wet steam is injected into thin layers of the oil, which has been preheated to 240-270° in a vacuum of 5-10 mm. The water droplets

vaporise suddenly and carry with them free fatty acids, which are subsequently condensed. A number of large-scale plants based on these principles is now in use. The processes were originally intended to combine removal of free fatty acid, decolonisation, and deodorisation in one process, but seem to have proved more useful when confined to the first of these processes, deacidification. With fats of the coconut or palm-kernel type, the fatty acids in which are of relatively low molecular weight (lauric, capric, caprylic), the free acidity of the crude fats can be reduced to a sufficiently low figure; but in the more usual types of fats, in which oleic and acids of similar molecular weight contribute most of the free acidity, it is not usually possible to reduce the free fatty acids in oils treated by these distillation processes to below about 1%. Nevertheless, the Wecker and Lurgi processes are valuable for reducing the acidity of crude fats with more than 5% free fatty acid to a figure of about 1%; the latter content of free fatty acid can then be efficiently dealt with by alkali refining in the ordinary way.

Finally, it may be mentioned that passage of crude fats through the "molecular still" at 100-250°/0-0001 mm. will effect, not only separation of free fatty acids present, but also evaporative distillation of the glycerides themselves. This procedure will thus separate a crude fat into: (i) non-fatty matter of lower molecular weight than the glycerides (e.g., vitamin A, and its esters); (ii) free fatty acids; (iii), the glycerides themselves; and (iv) a residue of non-fatty or of polymerised or oxidised fatty compounds. Although this process may well be applied to the preparation of certain vitamin A concentrates, it seems doubtful whether it will replace the previously discussed processes for removal of free fatty acids from fats (v. MOLECULAR DISTILLATION, Vol. VIII, p. 166a).

#### Decolonisation (Beaching) of Fats.

The natural colouring matters which find their way into many fats during the course of extraction of the latter are present in very small concentration—probably never exceeding 0.5% of the fat and very rarely approaching this figure. Most fats from vegetable sources are more or less coloured in this way, but only in a few instances (of which palm oil and cottonseed oil are typical) is the crude fat intensely coloured. The deep red colour of palm oil is due to the presence of only about 0.1% of carotene and other carotenoids, whilst the deep yellow or brown colour of crude cottonseed oil is similarly caused by the presence of somewhat larger amounts of the flavone derivative gossypol. The complete removal of these traces of coloured compounds is nevertheless frequently necessary, especially in the production of fats for edible purposes and high quality soaps. It has already been mentioned that a certain amount of decolonisation, especially when the cause of the colour is the presence of phenolic or similar compounds, takes place during alkali refining. The methods primarily employed to effect decolorisation of fats may be divided into two groups: (i) those depending on adsorption of the coloured

compounds by a suitable inorganic absorbent, and (ii) chemical methods, including oxidation, reduction, and treatment with sulphuric acid.

(i) *Adsorption Methods.*

The chief adsorbents employed are suitable types of fuller's earth, chemically activated fuller's earths, and adsorbent charcoals. Other materials, such as silica gel and diatomaceous earths, have been also proposed, but find relatively little application in so far as fat refining is concerned.

*Fuller's earth* (v. FULLER'S EARTHS, Vol. IV, 247a) is a siliceous mineral found in more or less isolated beds in association with greensand or gravel. The earth from different deposits varies in usefulness to the fat refiner, the most suitable deposit in general being in Surrey, and, in the United States, in Florida and some other localities.

\*The efficiency of fuller's earth in decolorising fats is much increased after gentle treatment of the earth with mineral acid; for instance, boiling with dilute (10%) aqueous mineral acid for 3 to 4 hours in a vessel fitted with mechanical stirring. Activated fuller's earths of this kind are specifically useful in the bleaching of palm oils, tallows and some other fats. The activation of the earth can be effected concurrently with the bleaching process by agitating about 4 parts of fuller's earth with 100 parts of the fat, adding 0.1-0.2 parts of sulphuric acid, and then heating to about 120-130°.

The concentration of fuller's earth (ordinary or activated) used in bleaching fats may be, according to the particular case, from 2 to 6% of the fat treated.

» *Adsorbent charcoals* (v. Vol. IV, 315c, 3176) used for fat decolorisation may include specific forms of wood charcoal e.g., from coconut or beechwood, and also wood charcoals of higher activity produced by special treatment during or after carbonisation. A common method of activation is probably exposure of the charcoal to a high temperature in presence of a controlled mixture of steam and air. The activated charcoals are sold under various trade names and the concentration to be used in decolorisation is usually of the order of 1% or less of the fat treated.

In some cases, a mixture of fuller's earth with smaller proportion of adsorbent charcoal is useful.

Whilst fats can be decolorised by filtration through a bed of adsorbent, the process is practically always conducted by mechanical agitation of a small proportion of adsorbent with the heated fat. Vessels with a capacity of up to 25 tons, fitted with mechanical agitation and heated by closed steam coils, are employed; preferably they should be closed so that the operation can be carried out in 2 moderate vacuum, and that air is excluded from the heated fat, whilst the latter is also freed from traces of moisture and also to some extent from volatile organic impurities. The temperature used varies according to the nature of the fat, but decolorisation by adsorbents is usually effected somewhere in the range 90-110°.

The method includes:

(i) Final clarification and bleaching of high

quality alkali-defined fats such as nut oils, groundnut, cottonseed, etc., oils. Agitation, with ordinary fuller's earth, or a mixture of the latter with active charcoal, at 80-100° for a short period, preferably under vacuum, is usually applied in these cases.

(ii) Clarification and partial bleaching of fats such as whale, fish, or vegetable oils, crude or alkali-refined, prior to hydrogenation or other chemical treatment. Fuller's earth or activated fuller's earth is usually employed, at temperatures of from 120-150°. The time of contact varies, with the quality of the crude fat and the temperature employed, and may be from 1 to 3 or 4 hours.

\* (iii) Bleaching of tallows for high-grade soaps, and of coloured vegetable oils, especially palm oil. Here it is desirable to use activated fuller's earth, sometimes with active charcoal in addition. The time necessary to effect complete bleaching may be considerably longer than in the previous cases, and the temperature must be carefully selected to give the optimum result.

In general, it is expedient to determine by laboratory trials the optimum proportion and type of adsorbent material, temperature, and time of treatment, for the fat which is to be decolorised in the plant.

When the decolorisation process is finished, the fat is filtered from the adsorbent in presses. Fat retained in the adsorbent press-cake may be recovered by solvent extraction of the latter, but its quality is naturally inferior to the filtered bleached oil; the extracted spent adsorbents are usually rejected, since the cost of reactivating them in most cases exceeds that of fresh earth or charcoal.

(ii) *Chemical Methods of Fat Bleaching.*

(a) *Oxidation Methods.*—The coloured compounds present in crude fats are frequently converted into colourless derivatives by mild oxidation, and oxidation processes are therefore available for fat bleaching. Clearly, however, there is always the possibility that some of the unsaturated glycerides of the fat may also be attacked, and in fact the flavour of fats is sufficiently affected by the mildest oxidation processes to render the use of these inadvisable in the treatment of fats destined for edible purposes. Oxidation is used, however, to some extent in bleaching fats for soaps and other technical products.

Agitation with air (preferably moist air) at about 90-110° effects decolorisation of palm oils and tallows, and has been used in refining these and other fats prior to using them in the soap pan; but great care is needed to avoid some concurrent oxidation of the unsaturated glycerides with consequent development of "burnt" colour and odour in the products. The use of *oxygenated air* and of *hydrogen peroxide* (in this case preferably in presence of 1% or so of sulphuric acid) has also been proposed in decolorising fats, but neither process appears yet to have been used to any wide extent.

Oxidation with *sodium dichromate* and hydrochloric acid is frequently used in bleaching tallows and palm oils for soap making. In the case of palm oil this method decolorises the oil

but, leaves it with the characteristic odour (resembling that of violets), which is not unwelcome in the final soap. Dichromate oxidation is effected by agitating the fats in lead-lined vessels at about 45-50° with a hot aqueous solution of sodium dichromate and hydrochloric acid ( $p \approx 14$ ); about 18 lb. of dichromate and 12 lb. of hydrochloric acid are usually required per ton of fat.

Oxidation with *sodium hypochlorite* or *bleaching powder* solution is also employed, especially for tallows. The operation is effected similarly, to dichromate bleaching, usually at a somewhat lower temperature.

(b) *Reduction Methods*.—Certain reducing agents effect removal of colour from fats, and more especially from soaps, but in general they are less effective bleaching agents for fatty derivatives than are oxidising agents. Moreover, the colourless reduction products frequently re-oxidise on exposure to air, so that the colour "reverts" to some extent, whilst fats and soaps bleached by reduction are usually somewhat dull in appearance. Nevertheless reduction processes have been used to some extent for bleaching soaps, the chief method being to heat the soap in the pan before it is grained out with a small proportion of one of the commercial forms of sodium hyposulphite or formaldehyde-sulphoxylate.

(c) *Treatment with Sulphuric Acid*.—In some cases agitation of a fatty oil with 1-2% of concentrated sulphuric acid at a slightly elevated temperature (up to 50°) effects decolorisation, probably by converting coloured impurities of high molecular weight into products which are precipitated to the bottom of the oil in the form of tar. The oil is then settled, drawn off, and washed with hot water to remove all mineral acid. Technical application of this method is confined to a very few fatty oils, but it has found use with linseed, rape, and a few other oils. Obviously the procedure must be carried out with adequate care to prevent local over-heating and polymerisation or other decomposition of unsaturated glycerides by the concentrated sulphuric acid.

#### Deodorisation of Fats.

Complete deodorisation of fats is only necessary when these are intended for edible purposes, but it is then essential. The process is the last to be undertaken in the refining of an edible fat, the crude fat having first been neutralised and subsequently clarified and bleached with an adsorbent material. The fat is heated in closed steel or aluminium vessels by high-pressure steam in closed coils, or by heated mineral oil or suitable compound circulated in closed coils, to a temperature of about 200-220°, the vessels being maintained throughout the process at the highest vacuum technically practicable (usually 10-25 mm.). Steam, de-aerated and superheated to 200° or higher, is passed in a fine stream through the oil and carries away with it to the vacuum condenser the traces of difficultly volatile compounds which cause the crude fat to possess a distinctive flavour. The process is continued until the fat passes the requisite flavour test, when the oil is cooled to

below 100° under vacuum prior to discharge. The time of treatment depends upon the character of the oil and the degree of vacuum employed, and may occupy from 6 to 12 hours. During recent years great improvements have been effected in the production of low pressures on a technical scale in connection with deodorisation processes, so that the time of exposure to the high temperature and superheated steam has been materially shortened, whilst the process can also be effected at a somewhat lower temperature than formerly. Both factors have combined to improve the quality of the refined, deodorised fats which are now available for margarine and other edible fatty products.

It has also been suggested to conduct the deodorisation in a continuous system so that the fat is exposed to high temperature only for a short time and in relatively small quantities at a time. It has also been proposed, as mentioned in a previous section, to carry out esterification and deodorisation in one stage by continuous processes. At present, however, it would seem that the discontinuous or batch process described above for the deodorisation of neutral, refined fats holds the field, having been brought to a high degree of efficiency by improvements in the vacuum employed, and in technical design and operation of the deodorisation plant.

### CHIEF CHEMICAL TRANSFORMATIONS OF FATS.

#### HYDROLYSIS OF FATS.

*Hydrolysis of Fats by Enzymes* (v. Vol. I, 395a; VII, 327d) (Lipase).—The tissues of plants contain more or less of the enzyme lipase, especially those (e.g. endosperm) in which fat is produced in quantity; here it is probably concerned in the biosynthesis of the glycerides from fatty acids and glycerol. Conversely, if fatty tissues or fats are exposed to moisture in the presence of lipase, the reverse action commences and the fats undergo partial hydrolysis (*hydrolytic rancidity*). Thus, fat-containing seeds which have not been stored under sufficiently dry conditions yield fats in which free fatty acids are present, sometimes in fairly high proportions, the seed lipase having acted as a hydrolytic instead of an esterifying enzyme, in presence of sufficient moisture. Fats may also undergo hydrolytic change, after they have been extracted from the plant or animal tissue, as a result of exposure to damp and infection with lipase introduced by bacteria or moulds which have developed on the fat surface. The more crude types of animal fats, especially low-grade fish oils and no. 4 grade whale-oil which are produced in part from the intestines of the animals, usually possess high free acidity owing to partial hydrolysis by lipase present in the intestinal micro-flora. The development of hydrolytic rancidity is prevented, as indicated earlier, by storage of fat or fat-containing tissues under dry and, as far as possible, sterile conditions; where absolutely sterile conditions are impracticable, measures such as storage at low temperatures or in an atmosphere containing sufficient carbon dioxide to retard the propaga-



tion of bacteria or moulds serve to suppress the breakdown of fats into free fatty acids.

The onset of hydrolytic rancidity is thus characterised by increase in the proportion of free fatty acids in a fat, and also by the development, to a somewhat indefinite degree, of hydroxylic compounds in the neutral fat. Fats which have undergone hydrolytic rancidity therefore possess acetyl values which may reach as much as 30 or 40, due to the step-wise hydrolysis of triglycerides first to diglycerides, and then, to monoglycerides, the free hydroxylic groups being those of the glyceryl residues in the latter two groups of compounds. Transient development of small optical rotatory power has sometimes been observed in cases of hydrolytic rancidity; this may be due to the partial hydrolysis of optically active asymmetric triglycerides (which however possess extremely small rotatory power),\* the corresponding di- and mono-glycerides having more definite optical rotations (cf. Fischer and Baft, Chem. Rev. 19 41-5, 9 287).

A technical process of fat hydrolysis in which plant (castor-seed) lipase is used to convert fats into fatty acids and glycerol has been developed and is referred to again in a later paragraph (p. 6 d).

**Hydrolysis of Fats by Alkali.**—Saponification of fats by boiling them with a dilute solution of caustic soda or caustic potash is the most common method of technical fat-hydrolysis, since soaps are produced in this way on an enormous scale. The details of the techniques applied are dealt with elsewhere, and here only a few general points need be pointed. The soap-boiling process demands attention to the relative concentration of fat, alkali, and water in order to secure a maximum rate of saponification, and the mechanism of the hydrolysis has been much discussed. Certain fats (e.g., the nut oils), which form more or less stable emulsions with caustic soda solutions, undergo progressive saponification when such an emulsion is left in the cold for a few hours. Both in this "cold process" and in the soap-boiling process the hydrolytic action is at first relatively slow, and then more or less suddenly accelerates to a more rapid rate which is thereafter steadily maintained. It was formerly supposed that this change in rate of saponification depended upon conditions being attained whereby the soap so far produced served to disperse the fat droplets into smaller particles more intimately emulsified with the aqueous alkaline phase. Lester Smith (J.S.C.I. 1932, 51, 337r\* Chem. and Ind. 1939, 87) has shown that this simple explanation, based upon activity at oil-water interfaces, is inconsistent with the progressive changes in rate of hydrolysis, and that interfacial action only accounts for the earlier, slow onset of saponification; so soon as sufficient soap has been produced, this soap (in which both fats and aqueous alkali are soluble) acts as a solvent medium for the reactants, so that the later, rapid stage of the saponification proceeds in a homogeneous system. This view accounts for the "autocatalytic" nature of saponification of fats by aqueous alkali, since the medium of the rapid homogeneous action is itself the product

of the process; moreover, the initial slow phase can be reduced or eliminated by adding soap or free fatty acid at the commencement of the reaction.

Occasionally, more especially in small factories on the Continent, fats are saponified by boiling with a thick cream of slaked lime (about 60% excess of that theoretically necessary) and water; when the process is completed, the lime soaps may be settled and washed from the lyes, or converted into a friable granular powder which can readily be washed with water. The lime soaps are converted into soda soaps by boiling with sodium carbonate solution, the calcium carbonate produced being subsequently separated from the soda soaps by "graining out" the latter with brine. The advantage of saponification with lime lies chiefly in the higher concentration of glycerin in the lyes produced, compared with that of lye from the ordinary soap-boiling process, whilst there is also some economy in the steam used for boiling the charge.

**Continuous alkali saponification processes** have been introduced in place of the ordinary soap-boiling method. Fats are emulsified thoroughly with the theoretical amount of caustic soda or sodium carbonate solution and then passed at a pressure of 50-100 atm. through a small-bore reaction tube, one part of which is held at about 300°. The actual operation of saponification lasts only 30 seconds. The extruded material is cooled and converted into soap powder by spray drying. As in the "cold process" of soap manufacture, the glycerin produced is retained in the soap and cannot be recovered separately.

**Hydrolysis of Fats by Water in Presence or Absence of Contact Agents.**—A number of processes are in use in which alkali is not employed during fat hydrolysis. These find application especially when the fatty acids are required as such, but they are also in some favour since, if soaps are the end product, the fatty acids can be converted into the latter by direct combination with sodium carbonate (use of the more expensive caustic soda being avoided). These processes also result in glycerin liquor of higher concentration than in soap-pan lyes, with consequent saving of heat for evaporation during glycerin recovery.

**Hydrolysis of fats by water alone** requires so high a temperature (200-220°) that until recently it was not technically feasible, but developments in design of high-pressure plant and in acid-resisting steels for chemical plant have now made such processes possible. Modern plants exist in which a mixture of fat and water is heated by superheated steam in closed coils in a pressure-resisting vessel to a pressure of, or greater than, 250 lb. per sq. in., the mixture being agitated by injection of steam at 200-220°. The action is allowed to proceed until 60-60% of the fat has been hydrolysed, when the aqueous glycerin liquors are withdrawn, fresh water added, and the process resumed to completion.

A continuous form of high-pressure hydrolysis has been proposed (Hoffmann, *Ole, Fette, Wachse*, 1936, 13, 4) in which fat is emulsified with water and passed through a heated zone at 220-260° under 20-60 atm. Hydrolysis is

almost instantaneous and the products are expanded suddenly into a high-vacuum phase wherein fatty acids and glycerol are vaporised, leaving the small proportion of unhydrolysed fat and non-fatty impurities in the liquid phase. Fractional condensation of the vapours yields first the fatty acids and, in a second stage, most of the glycerol as an 80-90% solution.

Long before high-temperature and -pressure hydrolysis of fats became practicable, a modified process operated at 140-150° and 100-120 lb. per sq. in. pressure (known as the *autoclave process* of fat-splitting) had come into common use, since it had been found that under these conditions fats were readily hydrolysed by water in presence of about 3% of basic metallic oxides such as lime, magnesia, or zinc oxide. The process is carried out in cylindrical (preferably copper-lined) autoclaves charged with a mixture of about 4 parts of fat and 1 part of water, to which 3% of lime, or lime and zinc dust, is added. (The zinc oxide present in the dust acts as a hydrolytic agent; the metallic zinc assists in retarding discoloration of the fatty acids.) The contents of the vessel are kept at 100-120 lb. per sq. in. pressure for about 12 hours, during which agitation is effected by passage of a current of steam; about 90% of the fat is hydrolysed in 3-5 hours, conversion to 98-99% fatty acids requiring, however, 10-12 hours. The finished product is discharged into a vessel where it is settled and the lower aqueous layer ("sweet water," which contains up to 15% of glycerin) drawn off for glycerin recovery. The layer of fatty acids is boiled with steam in presence of dilute sulphuric acid to decompose metallic soaps present, settled, and the fatty acids drawn off and washed.

The colour of autoclaved fatty-acids is always somewhat defective, even when the older process, in which the temperature does not exceed 150°, is employed; but this is not a serious trouble, since the autoclave or high-pressure processes are chiefly used when the fatty acids are, in any case, to be subsequently distilled in a vacuum before finding their final technical application.

Another method of fat splitting, that of *hydrolysis by sulphuric acid*, has been long employed in the case of bone greases and other fats of very low quality, in which the glycerin obtained would in any case be of no technical value. The crude dry fat is intimately mixed with 5-8% of 96% sulphuric acid and then heated with mechanical agitation in a current of dry steam at 110-120°, when hydrolysis is completed in 8-12 hours. The resulting fatty acids are naturally very dark coloured and, after removal of sulphuric acid by washing, require distillation in superheated steam or in a modern vacuum plant before they can be used. It appears possible that, even for low quality fats, this process will gradually lapse in favour of High-pressure hydrolysis by water (followed by vacuum distillation of the fatty acids).

*Hydrolysis of Fats by Water in Presence of an Emulsifying Agent.*—There remain to be mentioned two processes in which technical fat hydrolysis is carried out at atmospheric pressure

and at comparatively low temperatures. These are (i) the use of synthetic emulsifying agents which promote the hydrolysis of fats by water and (ii) the use of the natural hydrolytic enzyme lipase.

*The "Contact" or Twitchell Process<sup>1</sup> of Fat-hydrolysis.*—In this method the fat, mixed with up to its own weight of water, is heated to 100° and maintained in gentle ebullition with open steam in presence of a small proportion (1% of the fat) of one of the synthetic contact agents described below. Hydrolysis is completed in from one to two and a half days; but the process may be accelerated by interrupting it when about half complete, settling and withdrawing as much aqueous glycerin liquor as possible, and resuming the hydrolysis after addition of more water. When 97-98% conversion to fatty acids is reached, the charge is boiled with a little sulphuric acid to disperse any remaining emulsion, settled, and the fatty acids washed with boiling water. The "contact" process has advantages in cheapness of reagents, low steam consumption, and production of aqueous liquors with a glycerin content of up to 15%. The fatty acids produced tend to be discolored (although claims for specific contact agents include ability to produce good-coloured fatty acids), and are as a rule distilled in a vacuum still before technical use. The time necessary for hydrolysis is longer than in the processes previously discussed.

In the original form of this process, due to Twitchell, a hydrolytic agent prepared by condensing oleic acid with naphthalene in presence of sulphuric acid was employed; the naphthalene residue is condensed with the fatty acid and simultaneously sulphonated, so that the product contains (i) a group  $-\text{SO}_3\text{H}$  with strong attraction for water, and (ii) an aliphatic chain compatible with fatty compounds. Consequently the agent is able readily to emulsify fat with water, and presumably hydrolysis at the oil-water interface is catalysed by the strongly acidic sulphonic group, in attempts to lessen discoloration due to the particular contact agent employed, other compounds of somewhat similar type have been put forward in place of the original Twitchell reagent, such as p-cymene-sulphonic acid, condensation products of naphthalene and sulphuric acid with hydrogenated castor oil (hydroxystearic) acids, alkyl-naphthalenesulphonic acids, and sulphonated fractions from the refining of petroleum.

*The Lipase or Fermentation Process of Fat-hydrolysis.*—An active lipase extract which can be applied in large-scale hydrolysis of fats is obtained by grinding decorticated castor-seeds with water and centrifuging the resulting paste. The emulsion obtained separates on standing at 23° for a day or two into an aqueous layer and a creamy upper layer of emulsified castor-oil fatty acids containing the lipase, which is used as the hydrolytic agent.

The fat to be hydrolysed, which must previously be boiled with dilute sulphuric acid, settled, and thoroughly washed, is mixed with about half its weight of water and 7-10% of the ferment cream in wooden vats kept between 20-30° and agitated gently by air admitted through perforated copper coils. Hydrolysis is

completed, in the course of 24 hours or more, according to the activity of the ferment. The emulsified fatty acids are then broken by agitation with steam and settled, when a clear layer of acitls separates above a layer of emulsion, which must be separated and steamed in presence of dilute sulphuric acid to recover more fatty acids'. The lipase hydrolytic process yields fatty acids of excellent colour, and aqueous glycerin liquors up to 17% in strength, but somewhat contaminated by organic impurities; it has not come into very wide use, because of difficulties in producing a ferment cream of constant and sufficiently permanent enzymic activity, and in recovering the fatty acids from the somewhat obstinate emulsion which exists at the end of the hydrolysis. The process has the advantage of operating at little or atmospheric temperatures:

#### ADDITION OF OXYGEN TO UNSATURATED FATS.

Gaseous oxygen attacks the unsaturated linkings of the higher unsaturated fatty acids, esters or glycerides, leading to a sequence of products the nature of which is not in all cases well-defined. The oxidation proceeds steadily, if somewhat slowly, at ordinary temperatures, and much more rapidly at higher temperatures (e.g., 100-120°). Even in the earlier stages of oxidation at atmospheric temperature, the products formed have more or less definite and unpleasant flavour, and therefore the control of atmospheric oxidation of edible fats (leading to *oxidative rancidity*) is of great importance. On the other hand, intensive atmospheric oxidation of highly unsaturated fatty acids, such as linseed or tung oil, converts them into hard solid films, so that the action of oxygen on the fatty oil leads to products of definite value to the paint, varnish, linoleum, and some other industries.

The action of atmospheric oxygen on fatty oils is confined to the unsaturated groups of the acyl chains, neither the glyceryl linking nor the carboxyl groups of free fatty acids being affected. The rate of attack by oxygen depends, *ceteris paribus*, on the degree of unsaturation. Linoleo-glycerides are more rapidly oxidised than linoleo-glycetides, and the latter very much more rapidly than oleo-glycerides (Gunstone and Hilditch, J.G.S. 1945, 836). In the earliest stages the process is almost one of physical solution or, at all events, of production of very unstable oxygenated fat complexes, for the added oxygen can be removed again to a large extent by heating gently under reduced pressure. Simultaneously, however, the fat exhibits the reactions of an organic peroxide and the peroxide content augments steadily; at ordinary temperatures it may eventually reach a high figure, but at, e.g., 100° a lower maximum is comparatively rapidly attained, the peroxide content thereafter declining, evidently in consequence of further and more complex changes. The commonly accepted explanation of these changes was that a peroxide is produced by union of oxygen with an ethenoid group, followed by further transformation according to the general scheme:

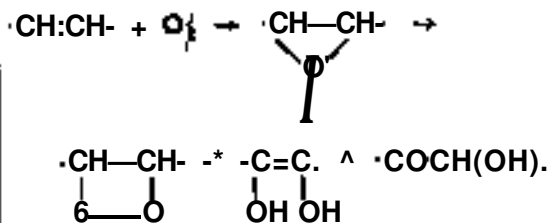

(v. Vol. VII, 326-7).

In the case of oleostearic esters, evidence of the production of hydroxyketonic or ketol derivatives of the type indicated has been given (Morrell and Marks, J. Oil Col. Chem. Assoc. 1929, 12, 183; Morrell and Davis, *ibid.* 1936, 18, 264, 359).

Recently, however, it has been shown that, in the oxidation of non-conjugated ethenoid long-chain acids or esters at ordinary temperatures, the initial product may be a hydroperoxide formed by union of oxygen with a methylenic group adjacent to an ethenoid bond, the latter remaining unaffected. Thus, with methyl oleate the product (Farmer and Sutton, J.C.S. 1943, 119) is:

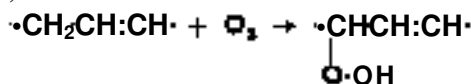

The initial action of oxygen on such a system was considered by Farmer to be the detachment of a hydrogen atom from the reactive methylenic group with formation of a free radical



which is in a state of resonance and may rearrange to

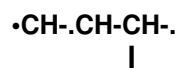

This leads, in non-conjugated polyethenoid systems, to the production of some conjugated ethenoid isomerides and their resultant peroxides (Farmer, Koch, and Sutton, *ibid.* 1943, 541; Bolland and Koch, *ibid.* 1945, 445; Gunstone and Hilditch, *ibid.* 1945, 836).

Subsequently production of polymers of high molecular weight may arise from these latter conjugated isomerides as such, or may be due to condensation products from ketol, etc., derivatives or other oxygenated products. This subject still awaits adequate explanation.

As oxidation proceeds, molecular fission at the original points of combination of oxygen with the unsaturated acyl chains may take place, short-chain aldehydes and acids being produced. The flavours of rancid (oxidised) fats may originate either from these or from the organic peroxides themselves. When peroxide formation (with subsequent secondary changes) has proceeded extensively in the more unsaturated "drying" oils, aggregation of the oxidised glyceride molecules sets in and thick, viscous ("blown") oils or colloidal gels or films (e.g., "dried" linseed or tung oils) may be formed (v. DRYING OILS, Vol. IV, 91c-93a).

The further details which may be mentioned in this article with reference to the atmospheric oxidation of fatty oils may be considered from the standpoints of the development of oxidative rancidity in edible fats and of thickened or colloidal film products from the more unsaturated or "drying" oils.

**Oxidative Rancidity in Edible Fats.**—The onset of oxidation is accelerated by various conditions and, correspondingly, can be retarded or minimised by measures which exclude the operation of these factors. The oxidation process is autocatalytic in the sense that the organic peroxides initially formed act as catalysts and, when once formed, accelerate the combination of oxygen with the rest of the unsaturated fat. Other substances, especially certain metals and metallic oxides (including copper, cobalt, iron, manganese, and some others) and some complex natural organic compounds (such as hsematin or enzymes of the peroxidase group) are active positive catalysts for the addition of oxygen to unsaturated fats. It is important for this reason to exclude all traces of these metals and their oxides (in practice, especially copper and iron) from edible fats. Plant for edible-fat manufacture should be constructed of resistant (*e.g.*, nickel-chromium, etc.) steel or of aluminium.

Atmospheric oxidation of fats is also much accelerated by light of certain wavelengths, notably by ultra-violet light waves of 290-400 *mμ*, and by visible light in the blue region of the spectrum of wave-length shorter than about 500 *mμ*, light of longer wave-length being comparatively or wholly inert. Oxidative rancidity of fats can therefore be retarded by storage in the dark or in vessels or wrappers coloured so that they do not transmit light of the active wave-lengths. The photochemical character of atmospheric oxidation of fats at low temperatures is utilised for "accelerated oxidation tests," in which fats are exposed to light of definite intensity under standard conditions of exposure to air, and the development of peroxides (*cf. infra*) plotted over a period of some hours or days; in this way the relative stability of different fats to oxygen during storage, etc., can be predicted with some accuracy in a test which occupies a comparatively short time compared with that taken by the fat to deteriorate under normal conditions.

**Inhibitors of Oxidation (Anti-oxidants).**—There are negative as well as positive catalysts of atmospheric oxidation of fats and, indeed, most fats and fatty oils contain traces of natural organic compounds (non-fatty in nature) which retard oxidation. To this fact is due the well-known phenomenon of an "induction period" at the onset of oxidation, during which little or no action occurs; subsequently oxidation sets in at a rate which increases rapidly to a steady maximum. This is explained on the hypothesis that such negative catalysts or "anti-oxidants" are selectively attacked by oxygen and, until they have been more or less completely oxidised, prevent the propagation of oxidation by a chain-reaction throughout the molecules of the fat glycerides (*cf. Moureu and Dufraisse, Compt. rend. 1W2, 174, 258; 175,*

127; Christiansen, *J. Physical Chem.* 1924/28, 145). Natural anti-oxidants which accompany fats are probably complex in character and of fairly high molecular weight, and are consequently largely removed from the fats during refining processes such as alkali neutralisation or treatment with adsorbent earths; for this reason refined edible fats are frequently much more prone to oxidative rancidity than the crude fats which contain a larger (albeit still minute) concentration of the protective factors. The nature of the natural anti-oxidants is not known with great certainty; probably the basis of most is the presence of compounds containing polyhydroxyphenolic residues, but such compounds also probably exist as complexes with, *e.g.*, carbohydrates or protein. It seems certain that none of the simple compounds which have been isolated from the non-fatty matter of crude seed-oils or the corresponding extracted seed-meals (*e.g.*, tocopherols Olcott, and MatMD, *J. Amw. Chem. Soc.* v1934, 56, 2405, 2492; 1936, 58, 1627, 2204, etc.; chromanuinols, *Gtoiumbic*, *ibid.* 1942, 64, 2337; polyhydroxyphenolic derivatives containing basic oxygen or nitrogen, wSilditch and Paul, *J.S.G.I.* 1939, 58, 21) have been obtained in a state of activity equal to that shown in their natural condition. The anti-oxidants in question have been shown (Hilditch and Paul, *I.e.*) to be present in much greater proportion in the extracted 'Seed-meal' than in the fats derived therefrom, and it seems possible that the complex of active anti-oxidant with other organic material in the endosperm is dispersible in the fat and affords a degree of protection greater than that which has yet been effected by addition of small proportions of known compounds of an anti-oxidant character.

A wide variety of artificial anti-oxidants have been recommended for the prevention or retardation of oxidative rancidity. In addition to synthetic compounds, reference may first be made to the use of cereal and soya-bean flours as anti-oxidants in fats (Musher). Hydroquinone, pyrocatechol, and other polyhydroxyphenols are powerful anti-oxidants in concentrations of the order of 0.05%, and other phenols, including *β*-naphthol and some other hydroxylated naphthalenes and anthracenes show similar action. Gallic acid and its esters have also been found to be efficient anti-oxidants for fats. Many substituted amino-compounds of the phenylenediamine, aminophenol, etc., series, thio-amino compounds, cyanamic derivatives, etc., also have anti-oxidant properties. Some aliphatic hydroxy- or amino-acids have been reported to have similar properties, %s also have lecithin, sulphites, and phosphates. In general, the presence of moisture tends to retard oxidation in fats. The use of these substances in edible fats is primarily determined by considerations of toxicity (which rule out many of them). For the rest, the value of a particular compound varies with conditions: for example\* a particular anti-oxidant may be more efficient in protecting fat in a homogeneous phase than when it is present as an emulsion with water, *e.g.*, in butter or margarine. Again, combinations of anti-oxidants of two different types (*e.g.* » tocopherol and an acid) may in some cases exert

a more<sup>1</sup> pronounced retarding action than either alone, whilst the physical state of the anti-oxidant compound and of the fat to be protected undoubtedly has a profound influence on the protection afforded. The practical application of anti-oxidants in controlling the onset of oxidative rancidity in fats has, in fact, not yet by any means reached a satisfactory solution *see* Hfdditch, Chem. and Ind. 1944, 67; Matill, Oil and Soap, 1945, 22, 1).

*Detection of Oxidative Rancidity in Fats.*—A number of tests for assessing rancidity, or proneness to rancidity, in fats have been put forward. The determination of organic peroxides present by measuring the amount of iodine liberated when 1 g. of fat is allowed to interact with potassium iodide in acetic acid solution is known to what is termed the "peroxide value" (Lea, Proc. Roy. Soc. 1931, B, 108, 175; J.S.C.J. 1934, 53, 388T; Wheeler, Oil and Soap, 1932; 9, 89). If they are "accelerated" by exposure to strong light (*supra*) they can be used to forecast approximately the rate at which a given sample of fat will develop oxidative rancidity under normal conditions of storage. It should be noted that a single determination of the peroxide value of a sample of fat of unknown history may not be informative, since a very rancid fat may have relatively little peroxide, the latter having already passed into other forms by secondary changes; a series of tests on the progressively oxidising fat is usually necessary in order to draw correct conclusions.

Other tests depend on the formation of trace products, acidic or aldehydic. In the Swift "heat-accelerated" test air is passed through the fat at 95° and subsequently examined by an indicator to detect the first formation of aldehydic compounds in the exit gases; the time taken to develop volatile acid compounds indicates the proneness of the fat to become rancid by oxidation. Similar tests designed to detect traces of aldehydic products are those of Von Fehenberg (restoration of colour to a fuchsin solution decolorised with disulphite solution), Schibsted (coloration redeveloped when a standard solution of rosapiline hydrochloride decolorised with sulphur dioxide is shaken with a solution of the fat in light petroleum), and Lea (direct volumetric measurement of the amount of bisulphite required to combine with the aldehydes present in 1 g. of rancid fat).

The Kreis-Kerr test for rancidity consists essentially in shaking a little benzene solution of phloroglucinol with the fat in presence of hydrochloric acid, when rancid fats cause the development of a pink colour, the intensity of which, under standardised conditions of test, can be made a guide to the degree of rancidity of the fat. The fat degradation product which reacts with phloroglucinol to the coloured compound is epihydrinaldehyde,

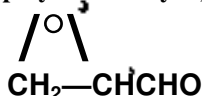

(Powick, J. Amer. Chem. Soc. 1924, 46, 1928). This compound is conceivably produced

by disruption of a molecule of peroxide (most probably from an inoleic group, e.g.,



or

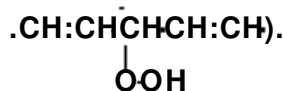

The Kreis-Kerr test has been further standardised by Tiffel and co-workers (1930-36).

*Ketone Rancidity.*—A special type of oxidation of the saturated acids from capric to myristic is effected by certain moulds of *Penicillium* and allied species, according to the following scheme:

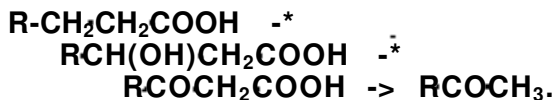

These lower saturated acids thus pass, by  $\beta$ -oxidation and decarboxylation, into methyl ketones, lauric acid, for instance, yielding methyl n-nonyl ketone (Stärkle, Biochem. Z. 1924, 151, 371). The methyl ketones possess a heavy characteristic perfume, which taints coconut and similar oils which have become subject to this form of oxidative rancidity. Ketone rancidity does not respond to the Kreis test, but shows a colour reaction with salicylaldehyde (Tiffel, Chem.-Ztg. 1932, 56, 265).

For a wider discussion of rancidity reference should be made to the monograph by Lea on "Rancidity in Edible Fats" (D.S.I.R. Food Investigation Rept. No. 46, 1938).

*Oxidation of Drying Oils* (v. Vol. VI, 926).—Amongst the few detailed studies of the constituents of an oxidised fatty-oil film are those of Morrell and co-workers (*l.e.*) who, in the case of elaeostearic glycerides, put forward evidence that, of the three conjugated ethenoid groups, that in the 1'-position yields a peroxide which rearranges to a ketol group, whilst that in the 3'-position remote from the carboxyl group forms a peroxide of basic character which is unstable, but takes part in polymerisation of the oxidised fatty molecules without isomerisation to a ketone derivative. Beyond this, little definite information has yet been offered as to the precise chemical constitution of oxidised "drying" oils. In the early stages of oxidation the mechanism is doubtless the same as in the onset of oxidative rancidity. With "drying" oils, however, it is technically desirable to accelerate instead of to retard the oxidation and thus to destroy rather than to augment the natural anti-oxidants in the crude oil. This underlies the technical conversion of raw into boiled linseed oil.

ACTION OF HEAT ON UNSATURATED FATS ("DRYING" OILS).

Fats and fatty oils, unless of the "drying" type, exhibit little alteration when heated in absence of air until a temperature of over 300° is reached; at higher temperatures decomposition sets in, acrolein being liberated from

the glycerol residues, whilst<sup>1</sup> some conversion of the acyl groups into hydrocarbons and also ketones of high molecular weight takes place. Under conditions similar to those used in the "hydrogenation-cracking" of petroleum oils (exposure to temperatures above 400° under high pressure of hydrogen and in presence of 2-3% of a catalyst, e.g., nickel) fatty oils undergo pyrolytic decomposition and yield hydrocarbon oils which can be used, after fractionation, for internal combustion engines. This possibility has attracted some attention in countries where vegetable oils are abundant and there is little or no indigenous supply of petroleum or coal (Maihle, *Compt. rend.* 1921, 173, 358, 658; Sato, *J.S.C.I. Japan*, 1927, 80, 242, 261; 1036, 39, 22B; *Auto-Engineer*, 1938, 28, 298; *Office du Niger, Bull. Mat. Grasses*, 1938, 22, 205).

**Thermal Polymerisation of •• Drying •• Oils** (v. Vol. IV, 88d-90c).—Fatty oils which contain high proportions of triethenoid acyl groups undergo polymeric changes when heated at temperatures between 280° and 300°. The behaviour of oils rich in conjugated triethenoid groups (tung and oiticica oils) differs sharply from that of oils (such as linseed or perilla) which contain no conjugated, but only linolenic and linoleic, glycerides, and may be considered first. In the course of a few minutes (9-10 minutes in the case of a good genuine tung oil) at 290-295°, tung or oiticica oils pass into a stable, friable colloidal gel solid at the ordinary temperature. The amount of conjugated unsaturation present in the gelled tung-oil is very much less than that in the original oil, and it may therefore be conducted that the polymerisation which has taken place has involved interaction or union at the conjugated unsaturated groups. Prior to complete gelation, tung oil at 290° passes through stages of thickening or increased viscosity ("stand oil" formation) analogous to those produced, but much more slowly, when linseed oil is similarly heated.

When Unseed oil is heated in absence of air at similar temperatures, two distinct phases of reaction may be distinguished. In the first place, the iodine value falls fairly rapidly to about 100, the specific gravity increases (from 0.92 to about 0.97), but there is only comparatively small increase in the viscosity of the oil; at this point (iodine value about 100) nearly all linolenic unsaturation has disappeared from the product, which is known technically as *thin stand oil*. On more prolonged heating of the oil at 290°, its viscosity rapidly increases until the "stand oil" produced is very thick and viscous, but still quite clear and with no tendency to form a solid gel; during this second phase there is comparatively little further reduction in iodine value. It is clear from the fall of iodine value in the first phase of heat treatment that a considerable part of the original unsaturation disappears owing to changes such as cyclisation or polymerisation. It is at present believed that such changes are preceded by rearrangement of non-conjugated to conjugated ethenoid systems in the unsaturated glycerides, for it has been observed that during this process the maleic-anhydride values of the oil increase somewhat and that, coincidentally, a certain

amount of ultra-violet absorption is developed at 230 m $\mu$  and 270 m $\mu$ ., characteristic respectively for conjugated di- and tri-ethenoid long-chain compounds (Bradley and Richardson, *Ind. Eng. Chem.* 1940, 32, 963). Feteger and Van Loon (*FetChem. Umschau*, 1935, 42, 217) fractionally distilled the products of heat treatment at 290° of ethyl linoleate, and detected the presence of about 5% of conjugated octadecadienoate, probably produced relatively slowly but then continuously transformed into polymerised non-distillable products.

The nature of the polymerides finally produced has also been experimentally studied, but the problem is very difficult. Waterman and Qosterhof (*Rec. trav. chim.* 1933, 52, 895) passed a thick linseed-oil stand-oil through a "molecular still" at extremely low pressure and separated it into about 30% of distillate of an average molecular weight of 760, and 70% of non-volatile polymers with an average molecular weight of about 3,500. Other investigators, studying heat-polymerised esters of individual (linoleic, linolenic, or elseostearic) acids, have isolated, *inter alia*, cyclic monomeric and dimeric products in the form of fairly mobile liquids which distil freely under a vacuum of about 0.2 mm., and thus are obviously intermediate or else side products lacking all the properties of the more completely polymerised oils. Cyclic monomers appear to contain six-carbon ring-systems formed from conjugated triene systems, but the structure of the cyclic dimers is less certain; possibly these also contain six-carbon rings, less probably the ring system may contain more than six carbon atoms or may be a cyclobutane system, or, again, rearrangement of an initially formed cyclobutane system

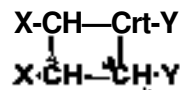

may take place to yield acyclic dimeric products such as XCH<sub>2</sub>CHY(jY:CHX, etc. (MorreD).

Beyond this, the many views which have been expressed as to the possible constitution of polymerised oils rest rather on hypothesis and speculation than on experimental evidence. It is generally agreed that both chemical and physical forces may come into action; but ordinary chemical changes account at least for the earlier stages of polymerisation, whilst, in the later stages leading to very viscous fluids or solid colloidal gels, forces of a physical, "van der Waals" type set up between the, remaining unsaturated groups of the chemically-polymerised molecules come into play (Bradley Kappelmeier, Rossmann). Wouuii. (*J. Col. Chem. Assoc.* 1936, 19, 42) distinguishes between two possible types of polymers: oriented, or fibrillar structures dependent on links of a chemical nature, and a plastic, non-oriented structure held together by cohesive or "van der Waals" forces. It is well also to bear in mind that intermolecular polymeric association of glycerides involves three-dimensional considerations and that union, for example, between two acyl chains in two different triglyceride molecules affects in all six acyl chains (four or

which may not be directly concerned in the change). The structural possibilities involved in the formation of a polymer equivalent in molecular size (say 3,660) to four or five combined triglyceride molecules are thus formidably complex. The possibility of something akin to mechanical interlocking of molecules by means of some of their long-chain groups (Jr<sup>0</sup>\*? \*an\* \*ette u. Seifen, 1937, 44, 189, 434), in addition to capillary or cohesive forces, should perhaps not be overlooked.

ACTION OF HYDROGEN ON UNSATURATED FATS.

The catalytic addition of hydrogen to unsaturated organic compounds in presence of nickel and a few other common metals, systematically studied in the vapour phase by Sabatier and co-workers, became of great technical importance when Normann showed that fats could be hydrogenated in the liquid state. Hydrogenation of fats is considered in detail elsewhere in this Dictionary *iff* HYDROGENATION, Vol. VI, 347c; CATALYSIS IN INDUSTRIAL CHEMISTRY, Vol. II, 422(2).

ACTION OF SULPHURIC ACID ON FATS.

In addition to the hydrolysing action on fats of concentrated sulphuric acid at temperatures somewhat above 100° (cf. *supra*, "Hydrolysis of Fats," p. 44ff), the interaction of sulphuric acid with two classes of fats at lower temperatures leads to products which have proved of technical value as textile detergents and also in special types of lubricating oils and emulsions. These materials, formerly known as "sulphurated oils," are more properly termed *sulphated oils*.

Sulphuric acid interacts readily with alcoholic hydroxyl groups when these are present in a fat, yielding the monosulphuric acid ester of the alcohol. The most important case is that of *sulphated castor oil*, in which the ricinoleic groups of the glycerides are converted by sulphuric acid into the *sulphuric esters*

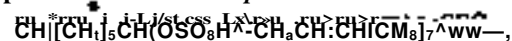

The alkali salts of the product, known since 1375 as *Turkey-red oil* because it was first used in preparing cotton for dyeing and printing with the alizarin dyestuff Turkey Red, are moderately good wetting and emulsifying agents with detergent qualities, and have been widely used in the textile industries. More recently, sodium salts of mono-sulphuric esters of the higher fatty alcohols, such as lauryl, cetyl, or stearyl, have become technical products of specific value either as detergents capable of use in hard water as well as soft water (owing to the solubility of calcium or magnesium salts of the alcohol sulphates) or as wetting-out, emulsifying, or dispersing agents.

Sulphuric acid also interacts, however, with the ethenoid groups of unsaturated fatty acids or glycerides. Thus, when *oleic acid* is treated with concentrated sulphuric acid at 0°, the action consists almost exclusively of addition at the double bond, yielding the sulphuric ester:

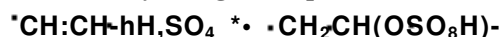

At 20° the ester is formed, but largely hydrolysed to hydroxy-stearic acid, most of which is further converted into *estolides* by condensation of the hydroxyl group of one molecule with the carboxyl group of another (Reiss, Collegium, 1931, 657).

Whereas sulphuric esters of this type are produced by the moderated action of sulphuric acid on oleic or ricinoleic acids, if the process is conducted under more drastic conditions, e.g., at temperatures of 35° or somewhat above, or in the presence of dehydrating agents such as acetic anhydride, fuming sulphuric acid, or chlorosulphonic acid, true sulphonic derivatives are produced instead of, or as well as, the sulphuric esters, the action proceeding as follows:

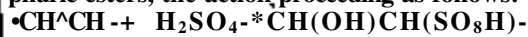

*Sulphated cod-* and some other *fish-oils*, *sulphated sperm-oils*, and *sulphated neat's-foot oil* are largely employed in fat-liquoring and "stuffing" emulsions in the leather trades, and also in cutting oils and some other special types of lubricants. *Sulphated oleines*, produced from technical oleic acids, also find similar use.

The technical analysis of sulphated oils and oleines demands somewhat different technique from the routine examination of fatty oils (cf. D. Burton and G. F. Robertshaw, "Sulphated Oils and Allied Products," A. Harvey, 1939).

ACTION OF HALOGENS ON UNSATURATED FATS.

Although they are not used to any large extent technically, the additive products of halogens and some other compounds with unsaturated fats and fatty acids are important both in qualitative identification and in quantitative measurement of mixtures of glycerides or fatty acids. Chlorine and bromine unite additively with the ethenoid bonds of unsaturated fats with comparative ease, but in the case of iodine the action is far from complete unless special agents are employed. The bromine additive products formed with linoleic and linolenic acids serve to characterise the latter (cf. this Vol., pp. 61d, 62b). Oleic and elaidic acids yield two different 9:10-dibromostearic acids, each of which reverts on treatment with powdered zinc to the acid, oleic or elaidic, from which it was produced. Hypochlorous acid, produced *in situ*, e.g., from sodium hypochlorite solution and a current of carbon dioxide, similarly unites with unsaturated fats or fatty acids, forming mainly chlorohydroxystearic acids (Albitski); these may be transformed by appropriate agents into oxidostearic, dihydroxystearic, and other acids. The study of these interactions has proved of value in connection with the stereochemical relationships of oleic, elaidic, and the corresponding oxyderivatives of stearic acid.

The most important application of the halogens, and of some other compounds with similar additive properties, lies, however, in the determination of unsaturation of fats (cf. OILS (FATTY) AND FATS, TECHNICAL ANALYSIS OF, this Vol., p. 52c). This is usually determined as the "iodine value," or absorption of iodine by 100 parts of the fat or fatty-acid mixture,



-and measured by allowing a solution of fat to stand in contact with a reagent containing iodine in a form which will combine quantitatively with the (non-conjugated) ethenoid unsaturation present.

Kaufmann (1925) observed that glacial acetic acid solutions of thiocyanogen,  $(\text{CNS})_2$ , can be made to react quantitatively with oleic acid and its glycerides, but do not unite completely with linoleic or linolenic acids and their glycerides. This has been made, in conjunction with iodine-value determinations, a means of determining the proportions of each of these acids or their glycerides in mixtures (such as the "drying" oils) which contain all three forms of unsaturation (v. this Vol., p. 616).

#### ACTION OF SULPHUR AND SULPHUR CHLORIDE ON UNSATURATED FATS.

When the natural (*cis*-) forms of oleic and other unsaturated glycerides are heated in presence of small proportions of sulphur at 200-230° isomerisation occurs and the equilibrium mixture of *cis*- and *trans*- (oleic and elaidic) forms is produced (Rankow, 1929); at the same time much of the sulphur becomes combined with some of the fatty oil. Selenium is a still more potent catalyst at 200-220° for this interconversion of geometrical isomerides (Bertram, 1936).

From a technical standpoint the action of sulphur on unsaturated oils at 130-160° is more important, since it leads to the formation of **vulcanised oils or factice—products which have been used as rubber substitutes or in special varnishes.** Oils such as linseed, castor, rape, cottonseed, and marine-animal oils, when heated with up to 40% of their weight of powdered sulphur for some time at about 150-160°, combine with the sulphur, apparently in somewhat analogous fashion to "that in which they combine with oxygen. The final product is a dark-coloured elastic, sticky or friable mass known as *factice* (v. Vol IV, 590a). Treatment with smaller proportions of sulphur gives dark, viscous, vulcanised oils which are used in leather varnishes.

Vulcanised oils are, however, more largely produced by the similar combination of sulphur chloride,  $\text{S}_2\text{Cl}_2$ , with the unsaturated fatty oils mentioned, which takes place readily in the cold. The process is usually conducted by adding sulphur chloride gradually to a solution of the oil in carbon tetrachloride. Hydrogen chloride is liberated during the action, but the products contain combined chlorine as well as sulphur. The materials finally obtained by combination of the oils with over 50% of their weight of sulphur chloride are cream or pale-yellow coloured elastic, friable masses, which find use as rubber substitutes. Lightly vulcanised oils containing 5-10% of combined sulphur somewhat resemble stand oils; in thin layers they dry slowly, yielding tough, elastic films which are very resistant to water. Such sulphurised oils are used as varnishes for leather and for rubber articles such as overshoes.

The mechanism of the action of sulphur on unsaturated fatty oils has been considered, *inter alia*, by Whitby (J.S.C.I. 1926, 45, 115T).

Knight and Stamberger (J.C.S. 1901, 2791), and Hollander (Farben.-Ztg. 1930, 85, 998).

#### BIBLIOGRAPHY OF FATS AND FATTY OILS.

1. J. Lewkowitsch, "Chemical Technology and Analysis of Oils, Fats, and Waxes," 6th ed., Vols. I-III, Macmillan & Co., Ltd., 1922-23.
2. G. D. Elsdon, "Edible Oils and Fats," Ernest Benn, Ltd., 1927.
3. E. R. Bolton, "Oils, Fats, and Fatty Acids," J. and A. Churchill, 1928.
4. W. Halden and A. Grun, "Analyse der Fette und Wachse," Vol. II, J. Springer, 1929.
5. O. Hefter and H. Schoenfeld, "Chemie und Technologie der Oele und Fette," Vols. I, II, IV, J. Springer, 1936-37.
6. T. P. Hilditch, "Industrial Fats and Waxes," 2nd ed., Baillière, Tindall, and Cox, 1941.
7. H. X. Brocklesby, "Chemistry and Technology of Marine Animal Oils," Fisheries Research Board of Canada, 1941.
8. G. S. Jamieson, "Vegetable Fats and Oils," 2nd ed., Chemical Catalogue Co. Inc., 1942.
9. J. A. Lovern, "Composition of Depot Fats of Aquatic Animals," H.M. Stationery Office, 1942.
10. T. P. Hilditch, "The Chemical Constitution of Natural Fats," 2nd ed., Chapman and Hall, Ltd., 1947.
11. A. E. Bailey, "Industrial Oil and Fat Products," Interscience Publishers, Inc., 1945.

T. P. H.

OILS (FATTY) AND FATS, TECHNICAL ANALYSIS OF. The following account of the methods used in the analysis of oils and fats includes all the methods of major importance in current use, but omits a number that have been employed in the past which have now become obsolete and are of historic interest rather than practical use.

Many of the methods dealt with have been the subject of standardisation, and are officially recognised in one country or another. In such cases the wording here given does not necessarily follow the official description as a considerable degree of compression has been necessary. The vast amount of work continually being published on the subject renders it impossible to have included full reference to all papers.

Attention has been confined to methods dealing with oils and fats themselves, and methods dealing with fatty foods, soaps, and certain technical oils are not included.

#### GENERAL.

For the purpose of analysis the fatty oils may be thus classified:

Crude and Refined Oils: Oils that have been subjected to one or more of the processes of neutralisation, bleaching, hardening, deodorisation, and esterification.

Manufactured Products: Stearines, oleines (pressed), cooking fats (compound lards), margarines.

Technical Oils: Boiled, blown, and stand oils, sulphur oils, sulphated oils, halogenated oils.

By-products: Soap-stock, acid oils.

Crude and Refined Oils are analysed for the assessment of their quality and in some cases special determinations are made for other purposes, e.g. the specific gravity of a sample of oil may be determined under strictly defined conditions of temperature and degree of solidification for the purpose of arriving at the weight

The superior figures following Authors' names refer to Bibliography at the end of the article.



of this parcel from which it was drawn, by calculation from an observed volume. Commercial contracts usually call for various standards\* of acidity, colour, and freedom from contamination by moisture, mineral matter, organic dirt, and mineral oils. There may also\* be contract standards of titre in tallows and peroxide value (indicative of liability to rancidity) in edible oils, and there will be a general requirement that the\* oil should be free from adulteration, and this can be determined only by a careful study of the various analytical figures found, and of corresponding data for likely adulterants. The payability of deodorised oils and the degree of success that has been achieved in preparing them are assessed by the subjective method of testing.

\* Tests generally applied\* for arriving at the degree of purity of an oil include melting-point, titre, specific gravity, refractive index, saponification value, percentage and iodine value of the unsaponifiable matter, iodine value, steryl acetate test, the Halphen, Saudouin and Fitecon colour tests, and test for arachis oil, and at times the thiocyanogen value. Tests of special value in dealing with Specific oils include:

Almonds, apricot, peach, and plum-kernel oils.	Bieber test.
Arachis oil	Determination of arachidic acid, smoke point, Acetyl value, viscosity, solubility tests.
Castor oil	Optical rotation.
Castorwood oil	Titre, Halphen test, smoke point, extinction $\rho_{589}^{20}$
Cashewnut oil	Halphen test.
Linseed oil	Insoluble bromides test.
Maize oil	Smoke point.
Oil of coccoloba	Maleic anhydride value.
Olive oil	Iodine value of unsaponifiable matter, Fitecon test.
Perilla oil	Insoluble bromides test.
Rape seed oil	Viscosity, flash point, iodine value of acids forming lead salts insoluble in ether.
Sesame* oil	Saudouin test.

Soya oil	Insoluble bromides test, determination of lecithin.
Teased oil	Fitecon test.
Tung oil	Polymerisation tests, unsaponifiable extract, maleic anhydride value.
Cod-liver oil	Cold test, blue value, tests for vitamins.
Halibut-liver oil	Blue value, tests for vitamins.
Shark oils	Blue value, unsaponifiable matter.
Whale oil	Test for fuel oil contamination.
Dolphin oils	Beichert and Kirschner values.
Coconut and palm-kernel oils, stearines and oleines	Beichert and Folenske values.
Cocoa butter	Jensen solidification test.
Bornéo tallow	Jensen solidification test, unsaponifiable matter.
Lard and lard stearin.	Melting-point and microscopic examination of crystals deposited from solution in ether.
Tallows	Titre test.
Butter fats	Beichert, Polenske, and Kirschner values.
Hardened oils	Lead salt separations, determination of fully saturated glycerides.

The normal limits of variation for the analytical figures of the commoner oils and fats are shown in the following tables, the data in which will be found of use in determining the nature of an unknown oil, as well as for the establishment of the purity of oils from known sources. All iodine values in the tables are determined by the Wijs method.

Manufactured Products.—The stearines and oleines produced from tallows, coconut oil, and palm-kernel oil by pressure bear obvious relationships to their parent oils, and the methods used for the examination of the latter are generally applicable. The manufactured products may exhibit a wide variation of hardness with corresponding variations in the analytical figures, and the general direction of these variations is indicated in the following tables.

TABLE I.—ANIMAL FATS.

	Cutter fats.				Beef tallows.			Lard.
	Cow.	Goat.	Sheep.	Buffalo.	Premier tallow.	Stearine.	Oleine.	
Melting-point: Incipient, °c.	—	—	—	—	—	—	—	—
Complete, °c.	28-34	27-38	—	—	47-49	50-54	variable	35-46
Solidifying point, °c.	19-24	24-31	—	—	32-37	47-50	—	25-30
Specific gravity at 15.5°C.	33-38	—	—	—	42-45	48-51	—	—
at 100/100° p.	0.933-0.944	—	—	—	0.937-0.953	—	—	—
Refractive index Zeiss at 40° c.	9.910-0.913	—	—	—	0.860-0.862	—	—	0.860-0.862
Refractive index at 20° c. (Stapom method)	42-44	45	45	42-45	47-49	46-48	47-49	—
Iodine value*	222-232	221-240	216-240	207-229	195-200	192-197	198-202	193-199
Beichert value	0.3-0.6	—	—	—	0.2-0.4	—	—	0.2-0.4
Polenske value	33-45	21-39	25-38	ca. 36	32-46	18-25	40-51	55-68
Kirschner value	24-33	20-29	23-33	28-33	0.2-0.9	—	—	—
Sat value (soluble)	1.7-3.5	—	—	—	—	—	—	—
Fatty-acid as oleic %	20-26	—	—	—	—	—	—	—
	57-70	—	—	—	8	15	12	—
	0.2-1	—	—	—	0.2-0.5	0.1-0.3	0.2-0.6	0.1-0.8

Technical tallow\* give similar figures with the exception of acidity, which may range up to 50%.

TABLE II.—FISH AND MARINE-ANIMAL OILS.

	Cod liver.	Halibut liver.	Herring.	Menhaden.	Sardine.	Whale.	Dolphin.	
							Body. *	Jaw.
Titre, °C.	17-18	—	20-30	—	25-28	22-24	—	—
Specific gravity : at 15.5/15.5°C.	0.922-0.929	0.922-0.925	0.917-0.930	0.929-0.931	0.932-0.935	0.921-0.926	0.931	0.923
Refractive index, Zeiss at 40°C.	67-73.5	66.5-79.5	58-63	79-81	70-73	57-5-60	59	29
Saponification value	180-190	170-180	184-191	188-194	188-192	193-197	215	275
Unsaponifiable matter %	up to 1.5	8-13	1-2.5	0.5-1.5	0.5-0.9	up to 1.5	1-2	16
Iodine value.	155-173	120-136	105-125	160-180	173-190	108-130	140	30
Free fatty-acid as oleic %	up to 0.6	—	2-8	2-7	1-4	up to 2.0*	0.3	—
Insoluble bromides %	30-35	—	10-25	ca. 50 "	—	20-30	—	0.5
Blue value (Carr-Price)	over 6	400-3,000	—	—	—	—	—	—
Reichert value	—	—	—	—	—	—	—	140

For grade 1 oil.

TABLE III.—VEGETABLE FATS.

	Coconut.			Palm kernel.			Palm oil refined.	Cocoa butter.	Borneo tallow.
	Oil crude.	Stearin refined.	Olein refined.	Oil crude.	Stearin refined.	Olein refined.			
Melting-point: Incipient, °C.	20-22	—	—	21-24	—	—	29*	30-32	30-36
Complete, °C.	23-26	26-31	16-22	26-29	32	26	400	32-34*	35-39
Solidifying point, °C.	22-23*	24-29	14-22	24-26*	27-32	23-26	251	27-29.5	28-32
Titre test, °C.	21-25	—	—	20-29*	—	—	44-2	48-50	50-52
Specific gravity: at 99/15°C.	0.869-0.874	0.860-0.869	0.870-0.875	0.859-0.870	0.866	—	—	0.8&	—
Refractive index, Zeiss at 40°C.	34*-35.5	34.5-34.8	35.5-35.7	360-37.5	355-36.0	37.5-37.9	46-49	46-47.5	45-47
Saponification value	255-258	252-255	257-262	244-249	249-252	244-246	196-206	192-198	188-207
Unsaponifiable matter %	0.15-0.06	—	—	0.20-0.80	—	—	rfV-1.5	0.8-1.2	0.7-2.0
Iodine value	7-9-9.5	2-0-7-9	11-15	14-5-19.0	40-14-5	19-30	46-52	35-40	29-38
Thiocyanogen value	—	—	—	—	—	—	—	—	—
Reichert value	6-5-8-0	4-5-6-0	8-10	5-2-6-5	3-0-5-2	3-5-9-0	—	—	—
Polenske value	15-17	8-15	17-20	9.7-10.7	7.5-9.7	10-7-	—	—	—
Kirschner value	1-6-1-9	1-0-1-5	2-0-2-5	0-8-1-2	—	13*0	—	—	—
Bartya value (soluble)	57	—	—	33	—	—	—	27	8-15
Free fatty-acid %	1-6*	0-1t	0-2t	0-5-10*	0-2-0-6t	0-2	01-0-4J	0-5-3	5-25
Colour reading (Lovibond) through 1 inch: Yellow	2-5	—	—	10-20	—	—	—	—	—
* d	0-6-12	—	—	0-5-1-3	—	—	—	—	—

\* As lauric acid. f t&amp;s oleic acid. } As palmitic acid.

Crude palm-oil may have f.f.a. from 2 to 85%.

The cooking fats (compound lards) and the fatty bases of margarines are mixtures of liquid and solid oils, blended to confer desired degrees of consistence and texture. As is the case with all solid products, the melting and solidifying points are of primary importance. In many cases the composition can be diagnosed, but it will often be found that no clear proof of the composition is possible. General indications of value are given by the saponification value, high figures usually indicating the presence of oils of the palms or butter fat, whilst Reichert, Polenske, and Kirschner values give a good idea of which of these is present and in what

proportion. Hardened oils are indicated by the presence of notable amounts of isooleic acid, as shown by the iodine value of the solid acids separated in the lead-salt separations; but account must be taken of the fact that tallows have been held to contain a small proportion of unsaturated acids yielding insoluble lead salts, whilst rape oil contains a notable percentage. Traces of nickel from the hardening process may be present if hardened oils have been included, and if found are a reliable indication of such oils\* but the absence of nickel cannot be taken to prove the absence of hardened oils, owing to the efficiency with which it can now be removed.

TABLE IVA.—VEGETABLE OILS.

	Umond.	Arachis.	Apricot kernel.	Castor.	Cotton.	Hemp.	Kapok.	Linseed.
Solidifying point, °C.	ca. - 2 0	0-3	—	—	—	—	—	—
Titre, °C.	—	a 27-30	—	—	32-36	14-16	25-32	13-17
Specific gravity: at 15-5/15-5°C.	0-918-0-920	0-917-0-919	0-917-0-920	0-958-0-969	0-921-0-924	0-928-0-932	0-921-0-923	0-931-0-936
Refractive index, Zeiss at 40°C.	56-5-57-5	55-57-5	—	63-70	58-59	70	53-57	71-5-79
Viscosity, Redwood: at 70°F.	—	300-420	—	—	295	—	320	—
at 100°F.	—	—	—	1,160-1,190	—	—	—	—
at 140°F.	—	—	—	—	—	—	—	—
Saponification value	183-207	188-194	192-198	177-187	192-195	190-193	190-197	188-195
Unsaponifiable matter %	—	0-4-0-0	—	0-3-1-0 & -90	0-8-1-8	1-0-1-5	—	0-8-2-0
Iodine value.	95-104	85-100	107-109	148-151	103-113	155-165	95-110	175-200
Acetyl value.	—	—	—	—	—	—	—	—
Free fatty acid as oleic %	0-4-2-0	ca. 2	1-4-2	0-5-10	1-5	ca. 1	variable	ca. 2
Arachidic acid of Jrt.p. 72°C. %	—	5	nil	nil	nil	nil	nil	nil
Insoluble bromides %	nil	nil	nil	nil	nil	nil	nil	30-42
Colour reading (Lovibond) »through 1 inci.» i								
Yellow . . . . .	3-5	16-41\$	—	up to 2-2	t 45-70	—	—	45-70
Red . . . . .	0-5-0-7	1-2	—	up to 0-25	t 4-9	—	—	2-5-6

2. Firsts oil " : crude oil, yellow 12-15, «J<L1-2.  
T /rude oil: common edible, yellow up to 3d, red up to 3-5; deodorised oil, yellow up to 7, red up to 0-7.

TABLE IVB.—VEGETABLE OILS.

	Maize.	Oiticica.	Olive.	Perilla.	Poppy.	Rape.	Sesamē.	Soya.
Solidifying point, °C.	—	—	—	—	—	—	—	—
Titre, °C.	14-16	—	17-25	—	15-17	£6-18	22-24	19-22
Specific gravity: at 15-5/15-5°C.	0-921-0-928	0-930-0-995	0-915-0-918	0-932-0-936	0-924-0-926	0-913-0-916	0-921-0-924	0-924-0-926
Refractive index, Zeiss at 40°C.	58-5-60-5	—	* 53-56	74-75	63-64-5	59-60	59-61	62-64
Viscosity, Redwood: at 70°F.	—	—	312	—	260	380-405	—	—
at 100°F.	—	—	90	—	—	—	—	—
Saponification value	188-193	190-193	188-195	193-205	192-196	170-177	188-193	190-194
Unsaponifiable matter %	0-2-5	0-6-0-9	0-7-1-5	1-0-1-5	ea. 0-5	0-6-1-5	0-8-1-5	0-7-1-8
Iodine value.	103-125	139-152	79-88	193-205	130-145	97-107	105-114	129-141
Free fatty acid %	overt	1-2-5	0-2-2	0-5-3-0	variable	0-5-2	1-5	0-5-3
Arachidic acid %	nil	nil	nil	nil	nil	nil	nil	nil
Insoluble bromides %	nil	nil	nil	nil	nil	nil	nil	nil
Heat test of app. v. B.S. 881, tr.	—	^ .18	—	—	—	—	—	—
H.Polymerisable matter % G. B. E.	—	ca. 40	—	—	—	—	ca. 40	—
Colour reading (Lovibond) »through 1 inci.» i								
Yellow . . . . .	—	00-90	12-40	40-60	—	30-45	up to 30	45-60
Red . . . . .	—	4-8	0-7-1 5	1-2	—	2-6	up to 3-5	4-6

\* Refractive index, r<sub>D</sub> at 25°C.: 1-512-1\*522.

In cases where the nature and amount of the solid base can be determined with reasonable accuracy, calculation by proportion will lead to analytical figures for the liquid base and a diagnosis of its nature can then often be made. In all cases it is well to bear in mind the commercial price of the oil as a guide to the likelihood of its presence. Various relationships are apparent between

the different analytical data for the majority of fatty oils, and some of these are dealt with by J. Lund.<sup>33</sup> Thus in the case of oils of saponification value ca. 190, the fatty acid) of which are straight-chain and non-conjugated, the specific gravities and refractive indices are proportional to the iodine values. Hydroxy-acids, as in castor oil, and conjugated acids, as in tung oil, raise the specific gravity and refractive index well above the values that would be

TABLE IVO.—VEGETABLE OILS.

	Sunflower.	Tung.	Hydnocarpus.	Teaseed.
Solidifying point, °o.	—	—	—	—
Titre, °o.	18-22	—	—	13-14.5
Specific gravity at 15-5/15-5°C.	0.924-0.926	0.939-0.943	0.950-0.960	0.916-0.918
Refractive index, Zeiss at 40°0.	60-63.5	—	69-5-76	52-5-55
Viscosity, Redwood at 70°F.	—	210	—	—
Saponification value.	190-194	189-195	198^204	MXM9&
Unsaponifiable matter %.	0-3-0-9	0-4-1-0	—	0-8-1-2
Iodine value.	125-140	155-175	97-103	79-87
Free fatty-acid as oleic %.	0-5-5	0-5-3	up to 12	0-3-8
Insoluble bromides %.	nil	nil	—	nil
Heat test of app. G, B.S. 391, min.	—	8-10	—	—
Unpolymerisable matter of app. G, B.S. 391	—	16-25	—	—
Specific rotation of 10% solution in chloroform	—	—	over 53°	—
Colour reading (Lovibond) through 1 inch:				
Yellow.	< 20-35 "	35-45	—	40-60
Red.	1-2	3-5-7.5	—	3-4

\* Refractive index, w<sub>20</sub> at 20°0.: 1-517-1-522.

At 25/25°C.

expected from this relation; the presence of lower fatty acids, as in butter fats and oils of the *palmae* depresses them.

**Technical Oils.**—Blown, boiled, and stand oils, used in the paint industry, consist of drying oils treated with driers, and more or less oxidised and/or polymerised according to the nature of the treatment they have received. Determination of the nature and proportion of driers is important, and lead, cobalt, and manganese should be sought. The extent of the oxidising or polymerisation are shown by the degree of reduction of iodine value, increase of viscosity, and formation of oxidised acids (acids insoluble in a relatively large amount of light petroleum). Changes in specific gravity and refractive index should also be noted.

**Sulphur Oils, i.e.,** crude oils extracted by means of carbon disulphide, may contain free sulphur. Sulphur olive-oil contains more resinous matter than the pressed oil, and the unsaponifiable matter is often in consequence 1-2% higher. This oil, which is at times of high acidity, and which may be highly fermented, can be refined by an esterification process with glycerine; the refined olive oil so produced has high unsaponifiable matter content (of low unsaturation) and a somewhat high specific gravity.

**Sulphated and Halogenated Oils** require special methods of analysis, and are not dealt with in this article.

**By-products.**—The value of soap-stocks is assessed from the content of total fatty matter or total saponifiable matter, and the value of acid oils is also assessed by the same means. The proportion of free fatty-acid in an acid oil may be determined by the usual titration method (see p. 62c), or the actual proportion by weight may be determined by extracting the free acids with aqueous-alcoholic potassium hydroxide from a light petroleum solution of the oil, and subsequently liberating them by means of mineral acid.

#### PREPARATION OF SAMPLE FOR ANALYSIS.

In order that representative portions of a sample may be taken for analysis it is almost

always necessary to tuel the sample at the lowest possible temperature which will ensure that melting is complete, and to snake it to ensure homogeneity. If the liquid is then clear and brigki analysis may be proceeded with immediately, but if the sample is turbid or contains suspended water or dirt a preliminary filtration through a paper, such as No. 4 Whatman, is carried out to remove all suspended impurities beffre chemical tests are applied. The original mixed sample is of course used for testing for water and impurities and in certain cases for unsaponifiable matter, specific gravity; or apparent density tests. Where filtration is conducted the resulting oil should be clear and bright before examination.

#### DETERMINATION OF WATER AND IMPURITIES.

##### WATPB.

Determination of moisture or water in oils and fats is made in one of two ways according to whether the oil is neutral and non-drying or otherwise. If it is neutral and non-drying, a weighed portion of the sample is dried to approximately constant weight in a water oven at 98°C. or in an air oven at 105°C. The drying process is prolonged until the difference between weights taken<sup>1</sup> at half-hourly intervals does not exceed 1 mg., the total loss in weight being regarded as moisture. If the oil is markedly acid, as in the case of acid oils, or is a drying oil liable to absorb oxygen when heated, the usual method adopted is that now standardised in British Standards such as B.S. No. 391, 1936; it is practically the same as that described by E. R. Bolton<sup>2</sup> (p. 15), which was in turn developed from the Standard Method agreed on by the Committee of Analysts of the Ministry of Food, 1919. In the British Standard method the apparatus used for the determination consists essentially of a drying tube (see Fig. 1) in which the oil to be dried is spread over a loose wad of asbestos fibre; the tube is maintained at about 50°o. in an air bath while the drying is carried out by means of a current of hydrogen or other inert gas, the loss of weight of tube and contents being taken as the weight

of \* moisture in the oil used. The tube, changed with long-ibred asbestos, previously moistened and air cMed, is placed in the air bath at 50°o. and the ary ga3 is passed through it until ft hpcomes constant in weight; it should be noted that the inert gas **must** always be replaced by air before weighing. The exit tubes of the tuba are covered b> rubber caps during

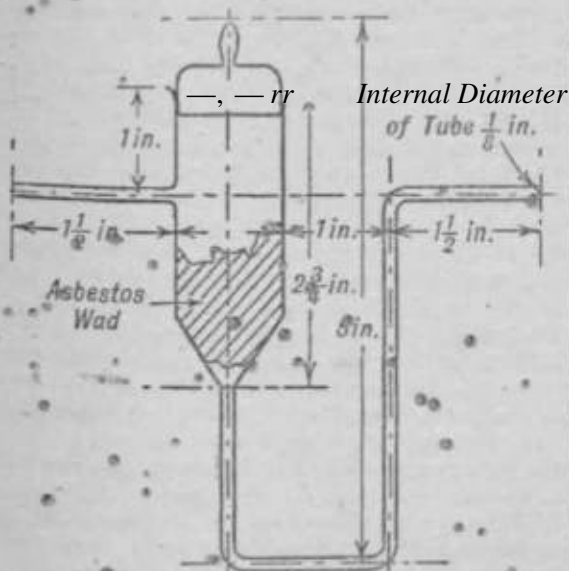

Fro. 1.

cooling aid weighing operations, 3-5 g. of the oil are weighed into the tube and distributed over the asbestos; the oil is dried by the passage of gas at 50°c. until the weight is constant.

Alternative methods for the determination of water are:

- (1) The determination of the loss in weight of a weighed quantity of the oil contained in a porcelain dish on heating to 105°c. over a Bunsen flame, a thermometer being used for stirring the oil and being weighed with it and the dish; this method is chiefly used in works control; it is quick but not of great accuracy.
- (2) The distillation of the water in the oil with an immiscible solvent such as toluene in an apparatus of the Dean-Stark type. This method is also not of great accuracy, but has the advantage that it gives a figure for the actual water content of the sample, as distinct from a figure for moisture and volatile matter such as is obtained by the usual methods. It forms the basis of the Internationally Agreed Method of B.S. No. 684, 1936.

#### IMPURITIES.

**Mineral Matter (Ash)** in an oil is determined by incinerating about 10 g. of the oil in a porcelain dish, continuing the ignition until the residue has disappeared, cooling and weighing the residue. If much fusible matter is present, the sample is charred and most of the oil is burnt off,

the residue is extracted with hot water and the extract filtered off. The filter and charred residue are completely ignited, the extract is added and evaporated to dryness and the whole is completely ignited with care. The ash is recarbonated if necessary, and ignition completed at about 500°c.

**Organic Dirt** is determined in most oils by filtering 2-50 g. of the oil in the water oven through a dried, plaited paper previously weighed in a stoppered bottle; the paper is extracted in an extractor until free from soluble matter with light petroleum (b.p. 40-60°c.), dried, weighed, and ashed. The weight of the ash is deducted from the weight of total dirt found, the resulting figure representing the weight of organic dirt in the oil used for the test.

The proportion of "foots" in linseed oil is determined, according to the Methods of Analysis of the Association of Official Agricultural Chemists (Methods, 5th ed., p. 114), by mixing together in a tube at 27°c, 25 ml. of the sample, 25 ml. of acetone, and 10 ml. of a reagent made by saturating with calcium chloride a mixture of 90 parts of water and 10 parts of hydrochloric acid; shaking for exactly 1 minute; clamping the tube in a vertical position, and allowing it to stand at 20-27° for 24 hours. The volume of precipitate is then determined to the nearest 0.1 ml., and when multiplied by 4 gives the percentage of foots. The tube used for the sedimentation should have an internal diameter of from 10 to 1.5 cm., a capacity of 70 ml., and should be graduated 10-50 ml. from the bottom.

In the cases of Cottonseed Black-grease, the acid oil obtained from the soap-stock produced in the refining of cottonseed oil by means of alkali, and of Sulphur Olive-oil, it is usual to employ carbon disulphide as solvent in a test similar to the above. This solvent retains in solution certain resinous or non-fatty matters that are not dissolved by light petroleum, and the proportion of organic dirt yielded is therefore lower than it would be if the latter were used. As the oils themselves are also solvents for certain dirt constituents, agreement has been reached in this country to proceed as follows in these cases: To 5 g. of the undried sample add 250 ml. of carbon disulphide. Stir at intervals until solution is as complete as possible and then allow the mixture to stand for about 12 hours in a covered vessel. Filter off the insoluble matter through a dry, weighed or tared paper, and thoroughly wash with cold carbon disulphide. Dry and weigh the insoluble matter. Add to the weight obtained the difference between the weight of the ash of the insoluble matter and the weight of the ash yielded by 5 g. of the sample. Divide the weight so obtained by 5 and multiply by 100 to obtain the percentage of matter insoluble in carbon disulphide. It will be observed that this figure includes certain mineral matters soluble in the solvent. Formerly it was not customary to make this addition, and in the case of Sulphur Olive-oils, it was usual to employ light petroleum in the above method in place of carbon disulphide. Attention may be drawn to the extreme inflammability of the hotter solvent, which renders it imperative to

ensure the removal of all carbon disulphide before the filter and dirt are dried in the oven.

**Sea Water.**—In cases where a sample is suspected of having been contaminated with sea water, the proportion of sea water in the water contained in the sample may be determined either from a determination of chlorine in the ash, or by extracting about 100 g. of the sample, dissolved in 500 ml. of light petroleum, with water and determining chlorine in the resulting aqueous extract. In such estimations it is usual to assume that sea water contains 2.5% of common salt.

**Fuel Oil.**—Whale oil is produced in very large quantities in floating factories which remain in the fishing grounds throughout the fishing season, and much of the oil they prepare is transported home in the transport ships which carry fuel oil to the factory ships, using the sal/ie tanks for this 'as for the whale oil produced. Great precautions are taken to clean tanks between cargoes, but occasionally slight contamination of the whale oil occurs; as little as 0.01% of fuel oil in whale oil seriously detracts from its value, and it has been alleged that it adds to the cost of refining and hardening the oil and leads to a refined material of dead appearance and poor colour, as the fuel oil cannot be removed commercially. The problem of detecting and estimating such traces of fuel oil has been dealt with by E. R. Bolton and K. A. Williams (*Analyst*, 1938, 63, &) who obtain a residue of hydrocarbon oil amounting to about half the percentage of the fuel oil if fuel oil is present, but a residue of only 0.003% or less if the oil is uncontaminated; the process employed consists essentially in preparing the unsaponifiable matter from 100 g. of the oil, by a double saponification and extraction process, heating the unsaponifiable matter with a specified amount of acetic anhydride, cooling and allowing to stand when the hydrocarbon derived from fuel oil separates and is removed, weighed, and examined. The method is empirical, and success depends on the observance of all the details of the published paper. Alternatively these authors have put forward a method for the detection of small amounts of fuel oil by the chromatographic adsorption of asphaltenes contained therein, a solution of the oil in light petroleum being passed through a column of specially prepared alumina; the adsorbent is re-extracted with ether, recovered, and submitted to the adsorption process a second time. 0.005% of fuel oil can be detected in this way.

Lecithin is found in certain oils, notably in crude soya-bean and arachis oils, especially if prepared by expression. It may be separated from the oil by treatment with a large volume of acetone, but this method does not lead to accurate figures for the percentage present. It is more usual to determine the proportion of phosphorus in the oil and, assuming this all to be derived from lecithin, to calculate the percentage of the latter by multiplying the amount of  $P_2O_5$  found by 11.366. Phosphorus may be determined by mixing a known weight of the oil with five times its weight of sodium carbonate, charring the mixture thoroughly, extracting the char with dilute nitric acid, filtering, and applying

Pemberton's method to the filtrate. The filtrate is made up to a definite volume, and 27 ml. of the solution, which should not contain more than 0.05 g. of  $P_2O_5$ , is placed in a conical flask. 10 ml. of nitric acid (p 142) are added and the solution is nearly neutralised with ammonium hydroxide, diluted to 70-80 ml., and heated in a water bath to 60-65°C. To this is added 25 ml. of freshly filtered molybdate solution, prepared by dissolving 25 g. of molybdic acid  $\text{P}$  a mixture of 36 ml. of ammonium hydroxide solution (p 0.90) and 68 ml. of water and adding the solution slowly with stirring to a mixture of 122 ml. of nitric acid (p 1.42) and 287 ml. of water, and then keeping for a few days and filtering. The mixture is stirred and kept at 60,65°C. for 15 minutes, and is then filtered through a Gooch filter prepared with a thin layer of well-washed asbestos. The precipitate and flask are washed with cold water until 20 ml. of the washings do not decolourise a mixture), of 0.5 ml. of 0.5N sodium hydroxide solution with 4 few drops of phenolphthalein solution. The asbestos wad and precipitate are carefully transferred back to the conical flask. 0.5N. Sodium hydroxide solution is added until the yellow precipitate has dissolved, completely, an excess of about 10 ml. being used. After, the addition of a few drops of 0.5% alcoholic phenolphthalein solution the contents of the flask are titrated with 0.5N. hydrochloric acid. The difference between the number of millilitres of sodium hydroxide and of hydrochloric acid used is multiplied by 0.001544 to obtain the weight in grams of  $P_2O_5$  in the 25 ml. of phosphate solution used for the test. See also Hutt and Weatherall (*ibid.* 1944, 69, 39).

Gossypol, a brown colouring matter in cottonseeds, finds its way into crude cottonseed oil in quantities of the order of 0.1%. It may be determined by the method of H. D. Royce, J. R. Harrison, and P. J. Deans (*Ind. Eng. Chem. [Anal.]*, 1940, 12, 741). The filtered oil (50 g.) is dissolved in light petroleum and diluted to 110-130 ml., and 10 ml. of a mixture of 4 parts of pyridine and 1 part of aniline are added. After thorough mixing, the solution is kept in a loosely-stoppered flask at 35-40°C. for from 7 to 14 days, the longer period being used if less than 0.01% of gossypol is present. The liquid is agitated once every day. The precipitate is collected by suction in a tared crucible and washed with light petroleum containing 1-3% of pyridine, until free from oil; the total volume of the washing liquid should not exceed 100 ml. Pyridine crystallisation is driven off by heating for 1 hour at 160°C. and the product is weighed as dianilino-gossypol, a factor of 0.775 being used to convert this weight to gossypol. If desired, the precipitate may be weighed as dianilino-gossypol-dipyridine if it is dried for 2 hours at 60°C. The factor in this case is 0.627. The method is claimed to recover 95-98% of the gossypol in a 0.1% solution, but with oils containing 0.01% the precipitation is slow and incomplete. Better results are obtained in such cases if a known weight of pure gossypol is added to the test oil.

C. M. Lyman, B. R. Holland, and F. Hale (*ibid.* 1943, 15, 489) determine gossypol in

cottonseed meal by photoelectric light-absorption method based on the colour developed by treatment of an extract in butyl alcohol with aniline.

**Break Test.**—The "break" in an oil, almost always present in crude drying oils such as linseed oil or semi-drying oils such as soyabean oil, is the material that separates from the oil when it is heated to an elevated temperature; it consists of non-fatty matter that has become dissolved in the oil during preparation and will mostly separate if the oil is tanked or allowed to stand quietly for a long period.

The modified Gardner break-test of the American Oil Chemists Society is described in a report of an American Chemical Society Committee on the analysis of commercial fats and oils (*ibid.* 1940, 12, 379) thus: The oil is maintained at 78° for 5 minutes; 25 g. are weighed into a 180-ml. beaker, and 3 drops of hydrochloric acid (p M9) are added and well stirred in. A thermometer, (30 cm. long, 6-7 mm. diam., bulb 13 mm., graduated -6° to 400° c. in 2°) is suspended in the oil with the bulb immersed but not touching the bottom of the beaker, and the latter is heated to 289° at the rate of 4° temperature rise per minute. The beaker and contents are cooled to 25° c. 50 ml. of carbon tetrachloride are added with stirring, and the whole is allowed to stand for 1 hour, with stirring at 15-minute intervals. The liquid is then altered through a Gooch crucible prepared with medium-fibre asbestos, the precipitate being transferred thereto. The crucible is washed with 100 ml. of carbon tetrachloride in 20 ml. portions, dried at 105° c, cooled, and weighed. The percentage of "break" is calculated from the gain in weight of the crucible.

#### METALLIC IMPURITIES.

Oils and fats dissolve small quantities of almost all metallic soaps. Those most commonly encountered are the soaps of sodium, iron, calcium, and nickel. Occasionally there are also found soaps of copper, lead, zinc, aluminium, and tin.

These metals may generally be separated from the oil, either by extraction with a suitable mineral acid, or by ignition of the oil and solution of the resulting ash in acid. Their detection and the determination of the amount present in the oil are then accomplished by means of the usual analytical processes.

Soaps of the alkali metals are often detected in works practice by boiling about 20 g. of the oil with water and a few drops of a solution of phenolphthalein to the cooled aqueous extract. A pink colour is produced in the presence of traces of soap.

The determination of nickel is of importance in the examination of hydrogenated oils; it is usually present in such oils to an extent greater than 1 part in 5-10 million of oil. The following method is given by E. R. Bolton (*ibid.* 18, 350) for the determination of nickel in oil: A 2-gram sample of the oil is incinerated in a platinum dish (a small quantity at a time). The ash is dissolved to 1-1.5 ml. of concentrated sulphuric acid by gentle warming. The solution is made distinctly alkaline with ammonia and filtered into a small tall-form beaker;

the filter is washed twice with 2 ml. of water, the washings being collected in the beaker; 3 ml. of a solution of 0.02 g. of a-benzildioxime in 95 ml. of 90% alcohol and 5 ml. of ammonia (p 0-880) are added. In the presence of nickel a characteristic pink colour is developed, and this may be matched against standard nickel solutions treated similarly to determine the amount of nickel in the oil.

Sulphur is sometimes found in oils prepared by extraction with carbon disulphide. It may be detected by saponifying a small quantity of the sample and adding a small quantity of an alkaline solution of a lead salt; a brown colour is obtained in the presence of sulphur.

#### TOTAL FATTY MATTER AND SAPONIFIABLE FATTY MATTER

The proportion of total fatty matter in an oil or fat is obtained by subtracting from 100 the sum of the percentages of moisture or water, ash, and organic dirt.

The proportion of saponifiable matter is obtained by subtracting from 100 the sum of the percentages of moisture or water, ash, organic dirt, and unsaponifiable matter.

In arriving at either figure all determinations are made upon the sample without preliminary filtration.

#### REFINING TESTS.

The American Oil Chemists Society and the American Chemical Society publish standard and tentative methods for the examination of soaps and oils which are revised annually, details of the revisions appearing from time to time in "Oil and Soap." Amongst the tests dealt with are tests for the loss occurring during the refining of various oils. For full details of these tests the standard methods should be consulted, but it may be said briefly that such tests are designed to measure the weight of oil recovered when the oil is treated in a standardised procedure with caustic alkali, which removes free fatty acids and impurities, and causes some loss of oil. The tests make provision for noting the colour of the refined oils produced and also their flavour and content of free fatty acid.

#### CHEMICAL TESTS.

##### MOLECULAR SIZE.

The Saponification Value, defined as the number of milligrams of potassium hydroxide required to saponify 1 g. of the fat completely, and the Saponification Equivalent, defined as the number of grams of fat saponified by 56.1 mg. of potassium hydroxide, give in general an indication of the mean molecular magnitude of the esters present. They are determined by weighing accurately about 2 g. of the fat into a 200 ml. conical flask, adding 25 ml. of approximately 0.5N. alcoholic potassium hydroxide solution, and heating the flask and contents under reflux condenser in a boiling-water bath for 30 minutes. The flask must be well shaken at intervals during the heating period to mix the contents thoroughly. A second flask containing only 25 ml. of the alcoholic alkali is similarly treated at the same time. After 30

minutes, the flasks are removed from their condensers and from the water bath, 20 drops of a 1% alcoholic solution of phenolphthalein are added to each, and the contents are titrated with 0.5N. hydrochloric acid, while still hot. The saponification value is obtained by multiplying the difference between the two titrations by 28.05 and dividing by the weight in grams of fat taken. The saponification equivalent is obtained by dividing 56,100 by the saponification value.

The 0.5N. hydrochloric acid should be carefully standardised; the 0.5N. alkali solution is prepared by dissolving 17.20 g. of potassium hydroxide, preferably in pellet form, of reagent quality, in the smallest possible quantity of water and making the solution up to about 500 ml. with 95% w/v alcohol. The solution is allowed to stand overnight and decanted from any sediment before use. The alcohol used in its preparation is preferably purified from industrial spirit by refluxing this with 2% of its weight of a fatty oil such as arachis oil and 5% of solid sodium hydroxide for 1 hour, and then distilling, the first and last few millilitres of distillate being rejected.

Certain fats are more easily saponified than others, and particular care is necessary with some to ensure complete saponification, extra shaking being given in such cases. In dealing with waxes it is generally necessary to employ a solution of sodium in alcohol in place of the above alcoholic alkali and this may need to be N. or 2N. in strength.

#### UNSATURATION.

The Iodine Value is a measure of the degree of unsaturation of a fat, and is determined by measuring the amount of halogen absorbed by the fat from various solutions; it is expressed in terms of the weight in grams of iodine absorbed per 100 g. of fat\*. A number of different methods have been proposed for the determination; in some a complete saturation of the double bonds present is achieved, in others only fractional saturation is aimed at. For approximately complete saturation the methods usually employed are those of Wijs, Hanus, and Rosenmund-Kuhnhenh, the more cumbersome and older method of Hubl being now superseded. Also of note are the Toms' bromine-vapour method and the thiocyanogen method of Kaufmann; thiocyanogen combines quantitatively with the double bond of oleic acid, approximately with one of the two double bonds of linoleic acid, and with rather less than two of the three of linolenic acid.

The Wijs Method depends on the absorption of halogen by the fat from an acetic acid solution of iodine monochloride. This solution may be prepared either by dissolving 8 g. of ICl in 450 ml. of acetic acid and 8.7 g. of iodine in a second 450 ml. of the acid, mixing the solutions, diluting to 1 l. with the acid, heating the product to 100°. for 20 minutes and cooling, or by dissolving 12.7 g. of iodine in 1 l. of acetic acid, determining the halogen content by titration of 10 ml. with standard sodium thiosulphate solution after the addition of water and excess potassium iodide solution, and passing a stream

of dry chlorine into the iodine solution until the halogen content as determined by further titration has been doubled, heating the product to 100°. for 20 minutes and cooling. In either case the acetic acid used must be glacial acid, containing not less than 99% of acetic acid, and of such quality that a permanent pink colour is produced when 0.2 ml. of 0.1N. potassium permanganate solution is added to 50 ml. For the determination, a weight of fat is taken which will absorb not more than 30% of the halogen used (J. J. A. Wijs, *Analyst*, 1929, 54, 14); this is weighed into a clean, dry, narrow-necked bottle of about 600 ml. capacity, provided with a stopper. 50 ml. of the ICl solution are added and the bottle is closed with the stopper previously moistened with a drop of 10% potassium iodide solution. The bottle is allowed to stand in the dark for 1 hour at 15-20°. and 20 ml. of 10% potassium iodide solution are then added to the contents, followed by 150 ml. of water, the contents shaken and titrated with 0.1N. sodium thiosulphate solution accurately standardised, starch being used as indicator. A blank determination, under the same conditions without the fat, is conducted at the same time. The iodine value is obtained by multiplying the difference between the blank and test-titrations by 1.269 and dividing by the weight in grams of fat taken. In the British Pharmacopoeia modification of the test (B.P. 1932, p. 578) the time of standing is 30 minutes and not 1 hour. A recent modification of the test by H. D. Hoffman and C. E. Greeff (*Oil and Soap* 1939, 16, 236) claims that the addition of 10 ml. of 2.5% mercuric acetate solution in glacial acetic acid to the test mixture induces complete absorption of halogen in 3 minutes.

In the Hanus Method iodine chloride is replaced by iodine monobromide, and the necessary solution is prepared by dissolving together 13 g. of iodine and 8 g. of bromine in glacial acetic acid and making the solution up to 1 l. with glacial acetic acid. The fat used in the test should absorb not more than half of the halogen added. The test leads to results which are in general slightly higher than those of the Wijs method, especially with highly unsaturated oils.

In the Hubl Method the halogenating solutions are (1) a 5% solution of iodine in 95% alcohol, and (2) a 6% solution of mercuric chloride in 95% alcohol. 8-15 hours are required for complete absorption from a mixture of equal volumes of the two solutions.

The Rosenmund-Kuhnhenh Method (Z. *Unters. Nahr.- u. Genussm.*, 1923, 46, 154) employs pyridine sulphate bromide as the active agent and in this reagent the pyridine sulphate appears to make the action of the bromine considerably more gentle than that of free bromine, and indeed than that of iodine monochloride. Thus the method can be used with advantage for determining the unsaturation of sterols and unsaponifiable matter (E. RV Bolton and K. A. Williams, *Analyst*, 1930, 55, 5) where the Wijs method gives erratic results.

H. Toms (*ibid.* 1928, 53, 69) describes a method (Bromine Value) in which films of oil spread on microscope slides are exposed at



room temperature so bromine vapour for 20-30 minutes. The excess of bromine dissolved by the oil is removed by a current of warm air and the percentage increase in weight of the oil is calculated in terms of iodine. The method leads to characteristic wrinkling of the films of certain oils\* and has been used in an investigation of the composition of tung oil by E. R. Bolton and f. A. Williams (*ibid.* 1930, 55, 363). The iodine value of tung oil presents difficulty in its determination owing to the anomalous absorption of halogen by systems of conjugated double bonds present in notable proportion in the elaeostearic acid combined in the oil. The recognition of this difficulty, which causes the iodine value as obtained in the usual Wijs manner described above to approximate to only two-thirds of the theoretical full absorption and to be rather indefinite, led A. C. Chapman (*ibid.* 1912, 37, 54) to suggest the use of three times as much Wijs reagent as usual and to extend the time of absorption to 3 hours. This method leads to an empirical figure which does not approach the full absorption, and is now little used. Figures approximating closely to absorption by all three of the double bonds of elaeostearic acid are given by the bromine method of H. Toms (*ibid.* 1928, 55, 69); and methods by which the figure obtained is limited to the equivalent of absorption of two of these bonds are given by E. R. Bolton and K. A. Williams (*ibid.* 1930, 55, 360; *Oil and Soap*, 1938, 15, 315) and by J. D. Von Meuscho (*ibid.* 1938, 15, 186). In these the iodine value is obtained by the Wijs method after two different times of absorption and an instantaneous iodine value is calculated by extrapolation to zero time.

The Thiocyanogen Value, first proposed by H. P. Kaufmann in 1925 (*Arch. Pharm.* 1925, 675) has been the subject of much investigation, and the following papers should be consulted: H. P. Kaufmann (*Seifens.-Ztg.* 1928, 65, No. 35), H. P. Kaufmann and M. Keller (*Z. anorg. Chem.* 1929, 4# 20, 73), H. P. Kaufmann and C. Lautenberg (*Ber.* 1929, 62 [B], 392), W. K. B. (1930, 26), M. J. C. S. O. C. Chem. Ind. Japan, 1930, 1000 K. B. N. S. H. Coy. (1931, 814), T. P. Hilditch and K. S. Murti (*ibid.* 1934, 43), The following is an abstract of the last-named authors' method: All apparatus is carefully dried before use. Glacial acetic acid and acetic anhydride are mixed in the proportion of 9:1 vol. and allowed to stand for a week. Phosphorus pentoxide, dried in a desiccator, is weighed into a brown reagent bottle, 500 ml. of the mixture is added, and the mixture is allowed to stand for 1 hour, and filtered through two thick layers of dried filter paper to yield a clear solution. The mixture is then cooled to 0°C, and the exact quantity being weighed to leave a 100% excess of the mixture in a 250 ml. flask. The flask is stoppered and pipetted in. The flask is closed and allowed to stand for 15 hours at 15°C, and it is found that no harm arises from prolonging

the time to this extent in any case.) A blank test is conducted alongside the determination. After standing, the reaction mixture is poured into 10 ml. of 10% potassium iodide solution, the flask rinsed with potassium iodide solution and water and the whole titrated with 0.05 N. thiosulphate solution. It may be noted that both T. P. Hilditch<sup>5</sup> (p. 52) and K. A. Williams (unpublished) prefer to add the potassium iodide solution and water to the reaction flask before the titration. The thiocyanogen value is calculated from the titrations in terms of the equivalent amount of iodine absorbed per 100 g. of oil. Hilditch and Murti and other authors recommend the use of the values 96 for linoleic acid and 166 for linolenic acid in calculations made from thiocyanogen values.

The proposal of a 0.1N. solution of bromine in methyl alcohol saturated with sodium bromide (stabilising agent) may be noted; this was made by H. P. Kaufmann and E. Hansen-Schmidt (*Arch. Pharm.* 1925, 263, 32).

Since maleic anhydride reacts quantitatively with conjugated double bonds, its use for their determination has been proposed by B. A. Ellis and B. A. Jones (*Analyst*, 1936, 61, 812) (Maleic Anhydride Value) and by H. P. Kaufmann and J. Baltes (*Fette u. Seifen*, 1936, 43, 93) (Diene Value) and these methods are applied especially to tung and oiticica oils. Ellis and Jones reflux together for 3 hours 3 g. of the oil and 25 ml. of a fresh 6% solution of maleic anhydride in toluene in apparatus fitted with ground-glass joints; pumice powder is used to prevent bumping. After cooling, 5 ml. of ether are added through the condenser followed by 20 ml. of water. The contents are then poured into a separator, and the rinsings of the flask with 20 ml. of ether and 25 ml. of water added. The separator is shaken and the contents allowed to separate. The aqueous layer is removed, the upper liquid extracted further with 25 ml. and 10 ml. of water, and the washings combined and titrated with N. sodium hydroxide solution to phenolphthalein. The maleic anhydride value (M.A.V.) is given by multiplying the difference between the titration and a blank titration, similarly obtained, by 12.692 and dividing by the weight in grams of oil used. Each conjugated set of bonds gives a M.A.V. almost identical with the iodine value of a single double bond in a compound of equal molecular weight. Further references to later work on the method are given by T. P. Hilditch<sup>5</sup> (p. 97).

Insoluble Bromine Compounds are formed by linolenic acid in ether solution, and by linoleic acid in light petroleum. These are used to characterise and determine linolenic acid in such oils as Unseed oil and in the investigation of the composition of many oils containing both acids. The reaction is applied in a variety of ways both qualitatively and quantitatively, the quantitative aspects being under review in 1939 by the International Commission for the Study of Fats.

K. Hazura (*Monatsh.* 1888, 9, 180 *et aeq.*) described the bromine compounds of various fatty acids. O. Hehner and C. A. Mitchell, dealing with these (*Analyst*, 1898, 23, 310), put forward methods for separating hexabromides of

m.p. 180-181°C. quantitatively from the fatty acids of linseed and other oils, and of insoluble bromides from oils; they describe the characteristic appearance of several of these. G. Halphen<sup>u</sup> (p. 192) (J. Pharm. Chim. 1901, [viii], 14, 359) modified the brominating agent and produced a qualitative test described by E. R. Bolton\* (p. 54) thus: In a small dry test-tube are placed 0.5 ml. of the oil and to this are added 10 ml. of a mixture of 28 parts by volume of glacial acetic acid, 1 part of bromine and 4 parts of nitrobenzene. The tube is then closed, the contents shaken, and the behaviour of the liquid noted. Such non-drying oils as coconut products, olive, castor, arachis, cotton, sesame<sup>l</sup>, poppyseed, etc., give no precipitate or only a very slight turbidity, even after standing for 1 hour. The drying oils, such as linseed, rubber-seed, hemp-seed, etc., and marine-animal and fish oils, such as whale oil, Japanese sardine-oil, etc., give a precipitate which settles more or less rapidly. Rape oil is distinguished by forming a turbidity, and the liquid separates on standing into two distinct layers, but resolves into a clear homogeneous liquid on mixing with an equal volume of ether. Tung oil gives no precipitate.

Hehner and Mitchell's quantitative method for the determination of the insoluble bromides from the fatty acids of an oil has been studied by a number of workers and may be applied in the form of a modification of a method of Gemmel (Analyst, 1914, 39, 297) described by E. R. Bolton<sup>s</sup> (p. 56). 1 g. of the dry fatty acids prepared from the oil with due care against oxidation is dissolved in 20 ml. of dry ether in a stoppered flask and the solution is cooled to 0°C. Bromine is added drop by drop slowly until a permanent reddish colour is formed. The flask is kept in ice water during the addition to prevent rise in temperature, and is then kept at 0°C. for at least 4 hours. The liquid is decanted, the crystals transferred to a suitable tube and centrifuged. After again decanting the liquid, fresh chilled ether is added, the crystals stirred with a weighed rod, and the tube again centrifuged. The process is repeated a third time, and the crystals are then transferred to a tared filter paper by means of a further portion of chilled ether, and dried to constant weight, and the percentage of insoluble bromides is calculated. The melting-point should be determined. The bromides so produced are either hexabromides from linolenic acid of m.p. 180-181°C. or octabromides from more unsaturated acids such as clupanodonic and arachidonic acid, which do not melt but blacken at temperatures over 180°C. The proportion of bromine in the bromides may be determined by decomposing a known weight with a solution of sodium in alcohol and determining the bromine in the sodium bromide formed. An estimate of the relative proportions of hexa- and octa-bromides present may thus be formed.

#### ACIDITY.

The acidity of an oil or fat is expressed in terms of its acid value, defined as the number of milligrams of potassium hydroxide required to neutralise the free fatty-acid in 1 g., or in

terms of the percentage of free fatty-acid present calculated as either lauric acid, in the case of crude oils of the coconut group, palmitic acid, in the case of crude palm oil, or oleic acid in the case of all other crude oils and fats and of all refined oils and fats.

Both Acid Value and Percentage of Free Fatty Acid are determined in general by the following method: The material is filtered through paper to remove water and dirt; 10 g. or a quantity sufficient to give a titration of not more than 10 ml., are weighed into a flask, and 50 ml. of alcohol (industrial spirit) at 70°C. just previously neutralised at 70°C. to phenolphthalein, are added. The contents of the flask are shaken with a swirling motion to cause the alcohol to extract the free acid, and are titrated while still hot with 0.1N. sodium hydroxide solution to phenolphthalein, mixing of the liquids being vigorously maintained during titration. The acid value is obtained by multiplying the titration by 5.61 and dividing by the weight of fat used. The percentage of free fatty acid is obtained by dividing the titration in millilitres by the weight in grams of fat used and multiplying the result by a factor; the latter is 2.82 for oleic acid, 2.56 for palmitic acid, and 2.00 for lauric acid.

In the case of bodied oils such as boiled linseed oil or of stand oils or tung oils it is preferable to dissolve 10 g. of the oil in 25 ml. of neutral benzene, add 50 ml. of cold alcohol, neutralised to phenolphthalein in the cold, and then conduct the titration in the cold. This forms the basis of the British Standard method for the determination, e.g., in B.S. No. 653, 1936. In the internationally agreed method of the International Commission, 150 ml. of a mixture of equal parts of 95% alcohol and ether are used similarly (B.S. No. 684, 1936). All three methods lead to the same results in most cases.

In cases where the actual percentage of free fatty acids by weight is required, as for instance in certain acid oils, the following method may be used; it is a modification of one due to G. S. Jamieson and W. F. Baughman (Official Monthly Bulletin Interstate Cotton Seed Crushers Association, Chemists' Section, August, 1922, p. 33).

Weigh 10 g. of the crude oil, or 2 g. of acid oil, into a separating funnel and add 50 ml. of light petroleum (b.p. 40-60°C); mix well. Add 10 ml. of 14% potassium hydroxide solution, stopper, and shake vigorously for 3 minutes. Add 25 ml. of 50% alcohol (v/v) and again shake for 15 or 20 seconds. Allow to stand until the mixture separates to two layers. Without delay draw off the lower layer to a second separator and shake with 20 ml. of light petroleum. Draw off the lower layer, after separation, to a third separator, and transfer the upper layer to the first funnel. Again wash the aqueous-alcoholic solution with 20 ml. of light petroleum and add the petroleum to the first separator. Wash the contents of this twice with 15 ml. portions of 50% alcohol, and add the washings to the alkaline extract. Transfer the combined extracts to a separating funnel, add an excess of hydrochloric acid, 200 ml. of water, and 90 ml. of ether. Shake until soaps have decomposed and the liberated fatty acids dissolve. Draw

off the lower layer, transfer the upper to a fresh funnel, return the lower layer to its funnel, and again extract with ether. Combine the ether extracts and wash them once with water. Transfer them to a weighed flask, evaporate, dry in the oven for a short time and

#### UNSAAPONIFIABLE MATTER.

The term unsaponifiable matter has generally been taken to indicate that fraction of a fat which does not combine with caustic alkali and is not hydrolysed thereby, but which is soluble in ether or light petroleum. Various methods have been proposed from time to time for its determination in oils and fats and it may be noted that many of these lead to most erroneous results. Amongst the now-discarded methods may be mentioned one in which the material separated consists of the fraction not extractable with a carbon tetrachloride solution of the fat by sulphuric acid, a process in which a dried and powdered soap prepared from the fat is extracted with ether. The available methods were reviewed by a Sub-committee of the Analytical Methods Committee of the Society of Public Analysts and Other Analytical Chemists (S.P.A.) in 1931-36 and as a result the Sub-committee developed a method which was in advance of any other when published, and still remains so. This method is very similar to that of the British Pharmacopoeia 1932 which was largely based on it; and it has been adopted in all British standards in which a requirement is made, for a limited unsaponifiable matter content. Its accuracy and reliability appear to be amply confirmed in an exhaustive review made by the International Association of Agricultural Chemists (I.A.A.C.) in 1938 in which comparison was made with the official F.A.C. method (Methods of Analysis of the A.O.A.C., 1940, p. 436), the continuous extraction method of Rogers (Oil and Soap, 1932, 16, 127), the modified Kerr-Sorber method (J. Assoc. Off. Agric. Chem. 1936, 9, 247), and that of G. S. Jamieson (*op. cit.*, p. 340). The S.P.A. method and the account of its development appear in the Sub-committee's Report No. 1 (Analyst, 1933, 58, 203) which states that the method was developed by the Subcommittee largely from that of E. R. Bolton and K. A. Williams (*ibid.* 1932, 57, 25), and that it was itself developed from an earlier method by the same authors (*ibid.* 1930, 55, 6). In this method unsaponifiable matter is defined as that which is present in oils and fats which, after saponification of the oil or fat by caustic alkali and extraction by the solvent specified (under the conditions detailed in the description of the method given later in this report), remains non-volatile on drying at 80°C. The method is abstracted as follows in various British Standards, e.g., B.S. No 653, 1936; the original report should be consulted for further details where required. Weigh accurately 2.0-2.5 g. of the oil into a 250 ml. flask and add 25 ml. of approximately 0.5N alcoholic potassium hydroxide. The alkali shall not be darker than a pale straw colour. Attach the flask and contents to a reflux condenser and heat on a boiling-water bath for 1 hour, with

occasional swirling to ensure complete saponification.

Remove the flask from the bath, detach the condenser and transfer the contents of the flask to a 250 ml. separating funnel, washing in with 50 ml. of water in all. Rinse the flask with 50 ml. of ethyl ether (p 0-720-0-724) and pour the ether into the funnel. Stopper the flask and shake vigorously while the contents are still slightly warm and allow the funnel to stand until the two layers of liquid separate and clarify. Draw off the aqueous alcoholic layer into the flask used for the saponification and pour the ethereal layer from the top of the funnel into a second 250 ml. separating funnel containing 20 ml. of water. Extract the aqueous alcoholic solution twice more, each time with 50 ml. of ether in the same manner, and combine the three extracts in the second funnel. If the extracts contain solid suspended matter pass them through a small dry fat-free filter into the second separating funnel, washing the filter subsequently with ether.

Rotate the extracts gently in the second funnel without violent shaking with the 20 ml. of water and, after allowing to separate, run off the wash water.

Wash the ethereal solution twice with 20 ml. of water, shaking vigorously on each occasion. Then successively wash with 20 ml. of aqueous 0.5N. potassium hydroxide, 20 ml. water, 20 ml. 0.5N. potassium hydroxide, and at least twice more with 20 ml. water. Continue washing with water until the wash water no longer turns pink with phenolphthalein.

Transfer the ethereal solution to a weighed flask and evaporate to small bulk. Add 2-3 ml. of acetone and completely remove the solvent from the flask by means of a gentle current of air, the flask being almost entirely immersed, held obliquely, and rotated in a boiling water bath. Dry the flask and contents to constant weight at a temperature not exceeding 80°C.

Dissolve the contents in 10 ml. of freshly boiled and neutralised 95% alcohol and titrate with 0.1N. alcoholic sodium hydroxide, phenolphthalein being used as indicator.

If the titration so obtained does not exceed 0.1 ml., calculate the proportion of unsaponifiable matter in the oil from the weight of the residue by dividing this by the weight of oil taken and multiply by 100, but if the titration exceeds 0.1 ml. the test shall be repeated from the beginning.

It may be noted that the various quantities of water and reagents have been carefully chosen and must be strictly adhered to. The ratio of water to alcohol to soap in the solution extracted has been chosen to give maximum ease of extraction by ether, and alteration of this ratio leads to incomplete extraction. This is exemplified in a draft method for the determination put forward by the Norwegian Standards Association (NS. 489: Norsk Hvalfangst-Tidende, 1938, p. 111) which E. R. Bolton and K. A. Williams (Analyst, 1938, 63, 652) have shown to lead to very low figures, and which Norwegian chemists have since agreed privately to be unsatisfactory; the method is stated (privately) to have been derived from German sources.

• The unsaponifiable matter separated by the S.P.A. Method includes, *inter alia*, hydrocarbons and higher alcohols and sterols, but is substantially free from free fatty-acids, soaps, glycerides, mineral matter, and volatile matter. Examination of the unsaponifiable matter has been shown to yield useful information in certain directions. Thus E. B. Bolton and K. A. Williams (*ibid.* 1930, 55, 5) have used a determination of the iodine value (I.V.) of the unsaponifiable by the Bosenmund-Kuhnnehn method to classify oils into four groups; the first of I.V. 64-70 including animal fats and fats of the coconut group; the second of I.V. 90-96 including fish and marine-animal oils and cocoa butter; the third of I.V. 117-124 including many if not all the vegetable oils except olive oil; and the fourth containing only olive oil with an I.V. of *ca.* 200. Later work has shown the classification to be less simple than was at first believed; thus olive oil from various sources may yield values approaching 300, and teaseed oils having values of 250 are fairly common. Nevertheless the method justified itself on its introduction by suppressing a widespread adulteration of olive oil with teaseed oil that had been practised on a large scale for many years.

Further work on the unsaponifiable matter of olive oil by J. C. Drummond and T. Thorbjarnarson (*ibid.* 1935, 60, 23) led to the isolation of squalene, present in the unsaponifiable matter to the extent of 31-64%; and this work indicates a satisfactory method for the separation of hydrocarbons from an oil. The method is one of chromatographic adsorption and consists in dissolving the unsaponifiable matter in a mixture of 90 parts of light petroleum (b.p. 40-60°C.) and 10 parts of benzene and passing the solution slowly through a column about 8 in. high of specially prepared aluminium oxide. The column develops distinct coloured zones when it is washed with a considerable quantity of the solvent mixture or with light petroleum, and each zone represents the part where a different set of compounds is adsorbed. All the unsaponifiable matter except hydrocarbons soluble in petroleum remain in the column, and the hydrocarbons can be recovered from the wash liquors for identification and estimation. A modification of the method has been applied to the detection of fuel oil in whale oil by E. B. Bolton and K. A. Williams (*ibid.* 1938, 63, 84) and is likely to find further extended use in analysis.

Animal and vegetable oils are differentiated by the type of sterols they contain, and much attention has been given to the separation of cholesterol and phytosterol and the subsequent formation of their acetates and determination of the melting-point thereof as a means of distinguishing these two classes of products and of determining the amounts of each in admixture.

The Sterol Acetate Test is best applied in the form of a modification reported by A. More (*ibid.* 1929, 54, 735) as devised by Van Sillevoldt of Leiden as follows: Saponify 15 g. of the filtered fat with 9.5 ml. of potassium hydroxide solution (100 g. KOH in 1,400 ml. water) and 20 ml. of alcohol (96%) in a 300 ml. conical flask provided with a reflux condenser.

Shake while warm until the fat is dissolved, and heat further for 30 minutes. Cool, add 10-20 ml. of digitonin solution (1% in 96% alcohol). Allow the mixture to stand for 24 hours in a cool place and filter on a Buchner funnel with a close-fitting paper. Wash with a small amount of alcohol to remove soap. The digitonin-sterol compound flakes off on drying. Weigh the steride and acetylate it with ten times its weight of acetic anhydride, and proceed with the crystallisation from alcohol (about 95%) as in the Bömer method (Z. Unters. Nahr- u. Genussm. 1901; 1902, 1018) which requires the crystallisation of the sterol acetates at least five times from alcohol with determination of the melting-point after each crystallisation. If the melting-point of the crystals after five crystallisations is below 115-116°C. the absence of phytosterol can be pronounced with certainty. An gradual rise of melting-point above 115°C. indicates its presence. The method allows the detection of quite small amounts of vegetable oil in admixture with animal oils, but it is not satisfactory in the reverse case. Indeed, though at first melting-points below 125°C. were taken to indicate the presence of animal oil, it has been shown by D. W. Stewart (Analyst, 1923, 48, 115) that m.p. of 122°C. and even lower may be quite normal for certain pure vegetable oils. It may also be noted that comparatively large additions of animal oil to vegetable oil having a sterol acetate of m.p. 127°C. can be made before the melting-point falls appreciably.

#### HYDROXY-ACIDS.

Very few oils contain notable quantities of hydroxy-acids, but castor oil is an exception, and a determination of these compounds by means of the acetyl value is an important item in the analysis of the oil.

The British Standard for the determination (B.S. No. 650, 1936) is as follows: Boil 10-20 g. of the oil with twice its weight of acetic anhydride (b.p. 137-139°C.) for 2 hours under reflux condenser in all-glass apparatus. Pour the solution into a 1 l. beaker containing 500 ml. of hot water and boil the mixture for 30 minutes, passing a fine stream of carbon dioxide through the liquid all the time. Allow the mixture to separate to two layers; siphon off the water. Repeat the heating of the oily layer with a further 500 ml. of water and the separation of the oil three times more to remove all acetic acid. Filter the acetylated oil through dry paper until free from water; if necessary use anhydrous sodium sulphate to assist the drying.

Saponify 5 g. of the acetylated oil with 50 ml. of 0.5N. alcoholic potassium hydroxide (accurately standardised) as in the determination of a saponification value; distil off the alcohol on a boiling-water bath and dissolve the soap in water. Add to the solution 0.5N. sulphuric acid in exactly the quantity equivalent to the alcoholic potassium hydroxide employed, and gently warm until the fatty acids separate completely as an oily layer. Filter and wash with boiling water until the washings are no longer acid and titrate filtrate and washings with 0.1 N. alkali. A slight excess of 0.6N. sulphuric acid, say 1.5 ml., may be used if difficulty is

experienced in obtaining separation, and if this is done the excess must be allowed for in the final titration.

Treat  $\frac{1}{5}$  g. of the original oil in the manner described above, starting with saponification with 50 ml. of 0.5N. alcoholic alkali. Then the acetyl value is given by multiplying the difference between the final titrations for the acetylated and nonacetylated oils by 5.61 and dividing by 5.

It will be seen that the acetyl value as determined by this method corresponds to the definition: the acetyl value is the number of milligrams of potassium hydroxide required for the neutralisation of the acetic acid obtained upon the saponification of 1 g. of the acetylated oil. Other definitions have been proposed and mention may be made of that of E. S. West, C. L. England, and G. H. Curtis (J. Biol. Chem. 1934, 47, 927) namely that the acetyl value should be the number of milligrams of acetyl taken up by 1 g. of the oil. These authors (*ibid.*) propose a method for the determination as follows: An oil is treated with a measured quantity of a mixture of acetic anhydride (1 vol.) and pyridine (1.7 vol.) the excess of anhydride is decomposed with hot water, and the acidity is titrated with standard alcoholic sodium hydroxide after addition of sufficient butyl alcohol to form a homogeneous solution. The acetyl value is calculated from the difference between this titration and a blank.

#### FATTY ACID SEPARATIONS.

Information is gained regarding the composition of fats and mixtures of fats by separation of their fatty acids into groups; thus by the separation of lead salts into fractions soluble and insoluble in organic solvents, fractions consisting of solid and liquid fatty acids are obtained; the solid fatty acids, including waxes, formed on hydrogenation, may have their iodine value determined to provide information regarding the hydrogenated oil, whilst the iodine value of the liquid fatty acids is also of importance. The empirical Reichert-Polenske-Kirschner process separates volatile fatty acids from the total fatty acids and HF, used in the analysis of butter fat and fats of the coconut and myristica groups. The Ave-Lallemant method has some use in the analysis of butter and depends on the separation of soluble barium salts of fatty acids. Arachidic acid is separated in crude form by the Evers test and characterised as arachidic oil, while separation of the insoluble bromides is used in dealing with drying oils. The separation of the fatty acids in fats is a P<sup>1</sup> separation of the fatty acids Ester % of the acid modification of the separation method. The separation may be made with ether or alcohol as solvent and in used. X<sup>TM</sup> A<sup>\*</sup> \* \* \* h<sup>B</sup>sheen widely recovered in this method, and certain advantages claimed appear to be based on a fallacy; consequently K. A. Williams recommends the following published modification of the separation process as the most satisfactory method.

Between 2 and 2.5 g. of the fat are weighed  
Vol. IX.—4

into a 250-ml. conical flask, 25 ml. of a 0.5 N. alcoholic potassium hydroxide solution are added and the fat is saponified as in the determination of the saponification value. The liquid is neutralised to phenolphthalein with glacial acetic acid added drop by drop, and if necessary a few drops of the alcoholic alkali are added to render the liquid just pink. The solution is evaporated as nearly as possible to dryness on a boiling-water bath, and the soap is dissolved in 50 ml. of hot water. An excess of a 10% solution of lead acetate in water is added, the presence of excess being judged by the disappearance of the pink colour of the phenolphthalein added for the previous neutralisation, which has incidentally deepened during the evaporation. The flask and contents are now heated in a boiling-water bath until the lead salts melt somewhat and adhere to the sides of the flask. The flask is removed from the bath and allowed to cool until the lead salts congeal. The aqueous liquid is poured off through a filter and the contents of the flask are washed with hot water. Any lead salts transferred to the filter are brought together by means of a jet of boiling water, allowed to cool and congeal, and are transferred back to the flask. The flask is drained of water, and when cool may safely be shaken to remove as much as possible; this removal is of primary importance, as water interferes with the subsequent processes. 100 ml. of ether are added to the flask, which is then warmed with great care on a warm-water bath to assist the solution of the soluble lead salts. When the bulk of the insoluble salts have become detached from the sides of the flask, the contents are cooled, and the flask is stoppered and allowed to stand for at least 18 hours. It should be shaken at intervals, and in general it will be found that during this period the insoluble salts separate in a powdery condition. If hard fats are being dealt with, lumps may persist, and should be broken up with a glass rod. The completion of the solution of soluble salts may be judged by the supernatant liquid becoming clear, initial turbidity disappearing when it is achieved. The contents of the flask are then filtered, the filtrate being caught in a 500-ml. separating funnel. The filter must at this stage be covered with a glass to minimise evaporation. The insoluble salts are carefully washed with ether, particular care being paid to the rim of the paper. When washed they are transferred quantitatively to a second funnel with ether. Excess of strong hydrochloric acid is added to each funnel, and each is shaken to cause complete decomposition of the salts. A large excess of water is then added to each, and the funnels are shaken and allowed to stand for the contents to separate. The aqueous layer is drawn off from each, and the ether layers are washed with water until all lead chloride has been removed. The ethereal solutions of the fatty acids so produced are transferred quantitatively to small flasks, evaporated, dried preferably in inert gas, and weighed. The iodine value of the solid acids is determined. The proportions of saturated acids, waxes, and liquid acids are calculated as follows, allowance being made here for the slight solubility of lead waxes in ether, and for the

impossibility of completely removing soluble lead salts from insoluble ones. These two factors are standardised in the determination and calculation, in which it is assumed that the fat under consideration is substantially neutral.

First obtain the percentage of total fatty acids combined in the fat by subtracting 12.7 from the saponification equivalent and dividing the result by the saponification equivalent. Compare this figure with the sum of the weights of solid and liquid acids recovered divided by the weight of fat taken and multiplied by 100. Provided the figures agree reasonably well, calculate the percentage of solid acids (uncorrected) and of liquid acids (uncorrected) from the weights of each recovered and the total weight of fatty acids recovered. Let these percentages be respectively  $S$  and  $L$ . Let  $I_s$  be the iodine value of the solid acids;  $I_w$  be the iodine value of the total fatty acids, obtained by dividing the iodine value of the neutral fat by the total percentage of fatty acids derived above and multiplying by 100;  $W$  the total weight in grams of fatty acids recovered;  $X$  the number of millilitres of ether used in separating the two classes of lead salts;  $I_l$  the iodine value (uncorrected) of the liquid fatty acids, calculated by proportion from  $S$ ,  $L$ ,  $I_s$ , and  $I_w$ .

Then the percentage of oleic acid present is given by:

$$S - [I_s - (100 - S)/15]/90 + 0.055X/W.$$

The percentage of saturated acids is given by:

$$100 - \{100 - [I_s - (100 - S)/15]/90\} - (100 - S)/167/f$$

The corrected percentage of liquid acids present is given by subtracting the sum of the corrected percentages of saturated and oleic acids from 100. If these liquid acids are known to consist only of linoleic acid and oleic acid, the proportions of the two acids can readily be calculated; if other unsaturated acids are present it is necessary to know which and in what proportion before the requisite calculation can be made.

This method is based on the original one of Gusserow (Annalen, 1828, 27, 153) modified by Varrentrap (*ibid.* 1840, 35, 196). It yields results similar to but not identical with those of the method proposed by E. Twitchell (J. Ind. Eng. Chem. 1921, 13, 806) emptying alcohol as solvent/ T. P. Hilditch and J. Priczman (Analyst, 1931, 56, 354) reviewing the latter method note that in general stearic acid is practically always absent from the liquid acids; palmitic acid is usually absent from them but has occasionally been observed in appreciable amounts; myristic acid passes to a considerable extent into the liquid acids; acids lower than myristic give lead salts increasingly more soluble in alcohol. Consequently, Twitchell's method gives lower percentages for saturated acids if lower acids are present, and it may be observed that this criticism applies equally to the ethereal method described above.

A method proposed by Bertram (Z. deut. Oel u. Fett Ind. 1925, 45, 733), in which an alkaline solution of soaps from 5 g. of fat is oxidised with potassium permanganate solution below 25°C. to break down unsaturated acids, the product is

extracted with light petroleum to remove higher saturated acids and oleic acid, and the latter is removed from the ammonium salts of the mixture as the magnesium salt, has been reviewed by T. P. Hilditch and J. Priczman (Analyst, 1931, 56, 354) who conclude "that both it and its modifications are subject to the same criticism as the Twitchell method.

The determination of solid unsaturated acids by lead-salt separation was reviewed by L. V. Cocks, B. C. Christian, and G. Harding (*ibid.* 1931, 56, 368) who found that the lead salts of the solid unsaturated acids produced in hydrogenation (oleic acid) are markedly soluble in alcohol but much less soluble in ether and light petroleum. They accordingly evolved a method using light petroleum for the lead-salt separation. 3.5 g. of freshly prepared fatty acids are dissolved in 50 ml. of 92-93% (by weight) alcohol and 3.45 g. lead acetate (if more than 25% solid acids are present) or 1 g. (if less) is dissolved in a further 50 ml. of similar alcohol. The two solutions are heated to boiling, and the lead acetate is poured into the other. After mixing and again heating to boiling the solution is allowed to cool slowly and kept at 15-20°C. overnight. The mixture is stirred and filtered on a 10-cm. Buchner funnel. The lead salts on the funnel and any in the flask are washed with 100 ml. of light petroleum (b.p. 40-60°C.) in 20 ml. portions, and the washings are distilled to remove the petroleum completely. The residue is dissolved by boiling under reflux with 20 ml. of alcohol (92-93% by weight) containing 1 drop of glacial acetic acid. The solution is allowed to crystallise for 3 hours at 15-20°C. The crystals are filtered and washed with 20 ml. of the alcohol, and they and those first removed on the Buchner funnel are decomposed by acid and the solid acids are recovered. The liquid acids are also recovered. The iodine value of the solid acid is determined, and the percentage of solid unsaturated acids, calculated on the assumption that such acids have an iodine value of 90, unless derived from rape oil, when the figure is 75.5. The method has the advantage of avoiding as far as possible the formation of insoluble lead oleate to which attention had been drawn by K. J. Williams and E. R. Bolton (*ibid.* 1924, 49, 460). These authors employ the determination of iso-oleic acid as a means of recognising the presence of hydrogenated oils in a fat.

The Reichert-Polenske-Kirschner Process yields figures depending on the amounts present of water-soluble volatile fatty acids, of water-insoluble volatile fatty acids, and water-soluble volatile fatty acids having soluble silver salts. These values are used in assessing the purity of butter fat and in characterising and determining various products of the coconut group of fats either alone or in admixture. An authoritative description of the process with fuller details than had hitherto been collected together was published by the Analytical Methods Committee of the Society of Public Analysts and Other Analytical Chemists (*ibid.* 1936, 61, 404), and this is based on the method described by E. Polenske (Z. unters. Nahr.- u. Genussm. 1904, 7, 273), with A. Kirschner's extension (*ibid.* 1905, 9, 66), which came into use



after the work of C. Revia and E. B. Bolton (Analyst, 1911, S6, 333). The process is an empirical one and satisfactory results depend on exact adherence to all the experimental details.

The following description includes all the necessary experimental directions of the S.P.A. report, from which it has been somewhat condensed.

Fats freed from the fat are steam-distilled in a still of standard dimensions; the correct data for the still and still head, etc., appear in the Analyst report referred to above and are reproduced in Figs. 2 and 3 (by permission); it should be noted that incorrect dimensions have appeared in certain other publications from time to time.

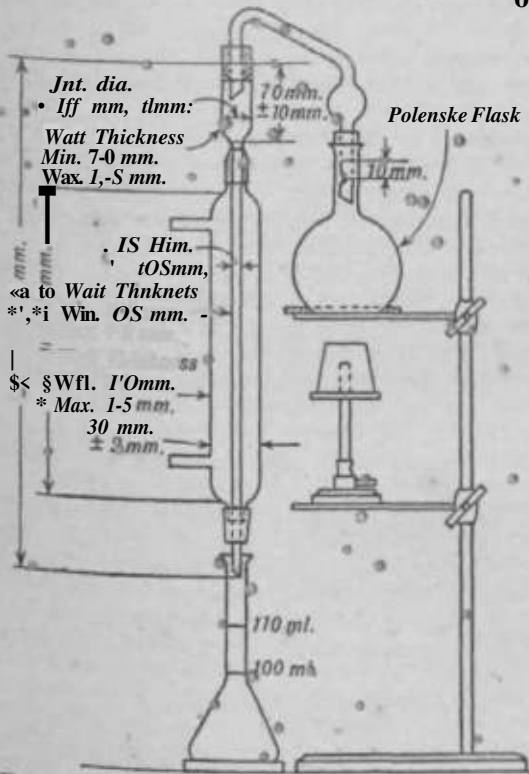

FIG. 2.—POLBNSKE DISTILLATION APPARATUS.

into a 100 ml. graduated cylinder, just previously rinsed with boiling distilled water. When the soap is sufficiently cool to permit addition of the water without loss, but before the soap has solidified, add the water to the flask, draining the cylinder for 6 seconds, and dissolve the soap. If the solution is not clear, or is darker than light yellow, the saponification must be repeated on a fresh sample of fat. Add 0.1 g. of powdered pumice (passing a sieve No. 50 but retained on a sieve B.S. No. 50), followed by 50 ml. of dilute sulphuric acid solution (of which 40 ml. neutralise 2 ml. of the concentrated sodium hydroxide solution), and connect the flask at once with the distilling apparatus specified. Heat the flask, without boiling, until the insoluble acids are completely melted, then increase the temperature

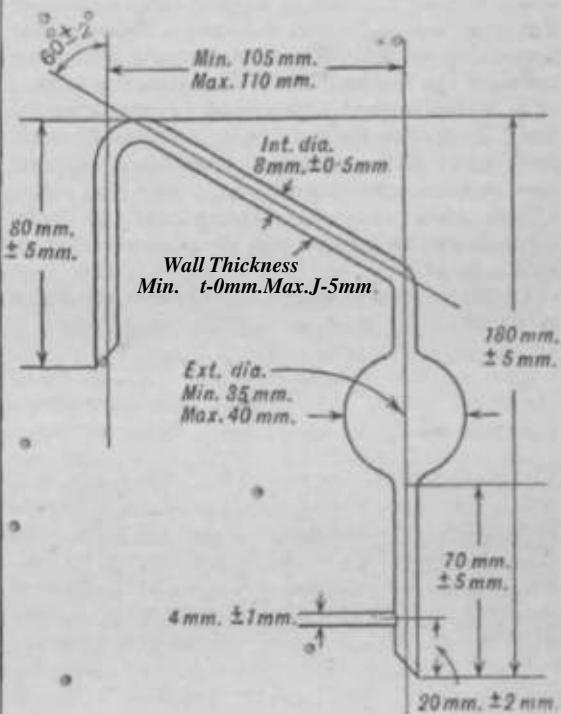

FIG. 3.—STILL HEAD FOR POLBNSKE DISTILLATION APPARATUS.

me fat into a Polenske flask. Add 20 g. of concentrated sodium hydroxide solution (sodium hydroxide dissolved in a equal weight of water and stored in a bottle with carbon dioxide; the clear upper portion is used). If this solution is clear, the latter must be produced by the withdrawal of carbon dioxide, the nozzle being ejected. Heat over a Bunsen burner with continuous mixing, until the liquid becomes milky. Cover the mouth of the flask with a watch-glass. Make a blank test without fat, using the same quantities of reagents and heating with soda (indicated by darkening of the solution). Measure 93 ml. of distilled water, vigorously boiled for 16 minutes,

distil 110 ml. in 19-21 minutes. When the distillate reaches the 110-ml. mark, remove the flask and replace it by a 25-ml. cylinder to catch drainings. Close the 110-ml. flask with a stopper, and, without mixing, immerse it beyond the 110-ml. mark in water at 15°C. for 10 minutes. Then remove it from the water, dry the outside, and invert it carefully, avoiding wetting the stopper with the insoluble acids. Mix the distillate by four or five double inversions without violent shaking. Filter through a dry 9-cm. Whatman No. 4 paper, fitting snugly into a funnel. Reject the first runnings and collect 100 ml. in a dry flask; cork the flask, and retain the filtrate for titration for the Beichert Value. The filtrate must be free from insoluble acids.

Detach the still head and wash the condenser with three successive 15-ml. portions of cold distilled water, passing each separately through the cylinder, the 110-ml. flask, and the filter, nearly filling the paper each time, and draining

each washing before filtering the next. Discard the washings. Dissolve the insoluble acids by three similar washings of the condenser, the cylinder, and the filter with 15 ml. (portions) of neutralised alcohol, collecting the washings in the 110-ml. flask, and draining the alcohol after each washing. Cork the flask and retain for titration for the Polenske Value.

**Reichert Value.**—Pour 100 ml. of the filtrate containing the soluble volatile acids into a dry titration flask, add 0.1 ml. of phenolphthalein solution (0.5 g. dissolved in 100 ml. of industrial methylated spirit), and titrate with 0.1N. barium hydroxide solution until the liquid becomes pink, rinsing the 100-ml. flask with the liquid towards the end of the titration. (The baryta solution may be replaced by 0.1 N. sodium hydroxide solution if the Kirschner Value is not to be determined.) The Reichert Value is obtained by multiplying the difference between the test and blank titrations by 10.

Note the actual volume of baryta solution used, drain the 100 ml. flask into the titration flask, close with a cork, and reserve the solution for the Kirschner Value.

**Polenske Value.**—Titrate the alcoholic solution of the insoluble acids after addition of 0.25 ml. of phenolphthalein solution until the solution becomes pink. The Polenske Value is obtained by subtracting the blank titration from that of the test.

**Kirschner Value.**—Add 0.5 g. of finely powdered silver sulphate to the neutralised Reichert solution. Allow the flask to stand (covered) in the dark for 1 hour, with occasional shaking, and filter the contents through a dry filter. Transfer 100 ml. of the filtrate to a dry Polenske flask, add 35 ml. of cold distilled water (recently boiled for 16 minutes), 10 ml. of the dilute sulphuric acid solution, and a loosely-wound 5-mm. coil of 30 cm. of aluminium wire (S.W.G. 18-20) or 0.1 g. of pumice powder. Connect the flask with the standard distilling apparatus and distil 110 ml. in 19-21 minutes, mix the distillate as before, filter it as before, and titrate 100 ml. of the filtrate with 0.1 N. barium hydroxide solution. Then the Kirschner Value is obtained by multiplying the difference between the test and blank titrations by 10 and by (100 + a) and dividing by 100, where a represents the actual volume in millilitres of barium hydroxide solution used in the Reichert titration.

Polenske values and, to a lesser extent, Reichert values are affected by barometric pressure, varying with the pressure. Suitable corrections have been given by V. H. Kirkham (*ibid.*, 1920, 44, 203) and are repeated in the S.P.A. report.

A semi-micro modification of the method is described by B. Dyer, G. Taylor, and J. H. Hamence (*ibid.*, 1941, 66, 55).

For the use of the test in determining coconut and palm-kernel oils and butter fat in mixtures, see E. E. Holton<sup>B</sup> (pp. 122-125).

Crude Arachidic Acid is separated from oils in order to confirm the presence and estimate the amount of arachis oil in mixtures and various tests have been developed from the original observation of J. Bellier (*Ann. Chim. Analyt.* ISM<sup>9</sup>, 4, 4) of the comparative insolubility of the

acid in 70% alcohol. Of these the following tests of N. Evere (*Analyst*, 1012, 87, 487; 1937, 62, 36) are undoubtedly the most satisfactory. The longer quantitative method is employed in the British Pharmacopoeia 1932 and in Various British Standards, e.g., B.S. No. 629, 1935, where it is thus described:

Boil 5 g. of the oil in a 200-ml. conical flask with 25 ml. of 1.5N. alcoholic potassium hydroxide for 5 minutes under a reflux condenser. Add to the hot solution 7.5 ml. of acetic acid (33% w/w) and 100 ml. of alcohol (70% v/v) of  $p$  0.890, to which 1 ml. of hydrochloric acid (sp. 1.16) has been added. Maintain the temperature of the mixture for 1 hour at 12-14°C. Filter the solution and wash the precipitate with the same mixture of alcohol (70%) and hydrochloric acid at 17-19°C, the precipitate being broken up occasionally by means of platinum wire bent into a loop, until the washings give only a faint turbidity in water. Note the volume of alcohol (70%, used for the crystallisation and washing. Dissolve the precipitate, in 70 ml. of alcohol (90% v/v) of  $p$  0.833 and cool the solution to a fixed temperature between 15°C and 20°C for 3 hours: then filter and wash with 30 ml. of alcohol (90%) at the same temperature and then with 50 ml. of alcohol (70%). Dissolve the crystals in warm ether and filter into a tared flask, the filter being well washed with ether and the washings added to the solution in the flask. Evaporate the ether and dry the residue at 100°C, cool and weigh. Determine the melting-point of the crystals, and if it is found to be lower than 71°C. re-crystallise from alcohol (90%), transfer to a tared flask, dry, and weigh as before.

To the total weight found add from Tables A and B, below, corrections for the solubility of the crystals in alcohol (00%) and alcohol (70%), in the latter case calculating the correction from

TABLE A

Weight of crystals obtained.	Correction (g.) to be added per 70 ml. of alcohol (70% v/v):		
	15°C.	17°C.	20°C.
0.05	0.0217	0.0250	0.0322
0.10	0.0252	0.0315	0.0364
0.15	0.0295	0.034	0.0400
0.20	0.0330	0.0392	0.0434
0.25	0.0364	0.044	0.0400
0.30	0.0330	0.0448	0.0407
0.36	0.0407	0.0478	0.0522
0.40	0.0427	0.047	0.0540
0.45	0.0440	0.0517	0.0507
0.50	0.0457	0.0532	0.0585

TABLE B.

Melting-point of crystals,	Correction (g.) to be added per 100 ml. of alcohol (70%),	Factor for converting corrected percentage of arachidic acid to arachis oil.
71.0	0.0190	170
71.5	0.0008	18.0
72.0	0.0080	20.0
72.5	0.0087	21.1
73.0	0.0000	22.0



the;toCal quantity of alcohol (70%) used in precipitating and washing, including the 100 ml. used in the first instance. Multiply this corrected weight in grams by 20 to obtain the proportion of crude arachidic acid present in the oil, and obtain the percentage of arachidic oil present by the use of the appropriate factor in Table B.

. N. Evers' qualitative test (*ibid.* 1937, 62, 96) designed for the detection of arachidic oil in olive and almond oils and eliminates much of the work required in the foregoing. It is as follows:

1 ml. of the oil is saponified with 5 ml. of 1.5N. alcoholic potassium hydroxide solution by heating on the water bath for 5 minutes, avoiding loss of alcohol; 50 ml. of 70% alcohol are added, followed by 0.8 ml. of hydrochloric acid (9 It46). After heating to dissolve any precipitate that may be formed the solution is cooled in water, and continuously stirred with a thermometer, so that the temperature falls at a rate of about 1°C. per minute. If a turbidity appears before the temperature reaches 9°C. in the case of olive oil, or 4°C. in the case of almond oil, the above quantitative test for arachidic oil must be carried out; but if the liquid remains clear at these temperatures, arachidic oil may be regarded as absent. Clouding points for other oils are given in the original paper. \*

The Aze-Lallemand Baryta Value Test depends on the separation of fatty acids having barium salts soluble in water, and has been used in the analysis of butter fats suspected of being adulterated. The test is described in full by K. R. Bohm (p. 53): owing to the rise of popularity of the Reichert-Polenske-Kirschner test, which gives similar and more definite information, it is not little used. A few figures for the soluble baryta value are given in Tables I-III (pp. 53, 54). Comparisons of other individual fatty acids than those already referred to are not made in connection with this analysis, but it may be noted that on the other hand saturated fatty acids may be recovered from insoluble bromides precipitated in organic solvents by removal of bromine with zinc and hydrochloric acid in alcoholic solution, and what the formation of elaidic acid has been used to characterise the presence of oleic acid. This has been achieved by J. J. E. Poutet (Ann. Chim. Phys. 1819, [ii], 12, 58) by means of mercury and iodine, and the test has been the subject of a quantitative study by H. N. Griffiths

showed that Uditch (J.C.S. 1932, 2315) who about 10% of elaidic acid was obtained from either of the two mixtures containing either of the two acids or their esters.

of fat. The chemical composition for the various fatty acids present, and also methods for determining in what manner these acids are grouped on the glyceryl residue. The modern methods for this work have been developed largely by T. P. Hilditch and his co-workers; an account of this appears in T. P. Hilditch (p. 367). The following brief note has been abstracted

of the amounts of the various fatty acids present, and also methods for determining in what manner these acids are grouped on the glyceryl residue. The modern methods for this work have been developed largely by T. P. Hilditch and his co-workers; an account of this appears in T. P. Hilditch (p. 367). The following brief note has been abstracted

of the amounts of the various fatty acids present, and also methods for determining in what manner these acids are grouped on the glyceryl residue. The modern methods for this work have been developed largely by T. P. Hilditch and his co-workers; an account of this appears in T. P. Hilditch (p. 367). The following brief note has been abstracted

their methyl or ethyl esters into a series of fractions containing substantially not more than two saturated esters and not more than two homologous groups of unsaturated esters. Before fractionation is attempted however it is usually best to make some preliminary separation, not necessarily complete, but tending to group roughly acids of similar properties into two or three main sets of esters. Such groups are more easily dealt with than their mixture in the original fatty acids.

The first process consists in the preparation of the mixed fatty-acids of the fat, generally from 70 to 100 g. of the latter, by saponifying in a manner similar to that used in the titre test (p. 77f). Care must be taken to ensure complete saponification of the fat, and when highly unsaturated acids are present the saponification must not occupy too long a time, to minimise changes produced in these acids by prolonged boiling with alkali.

Unsaponifiable matter is next removed as completely as possible from the soap solution by continuous extraction with ether in a suitably designed extractor. In this extraction the soaps are in solution in an aqueous-alcoholic menstruum; the solution should be as dilute as possible and the ratio of alcohol to water should be about 1:2. After the extraction the ether is washed with water to remove soap, which is added to the main soap solution. Alcohol is removed from this, and the mixed fatty acids are liberated as in the titre test (see p. 77(2)), and recovered. Volatile fatty acids are removed as completely as possible by steam distilling and extraction from the distillate with ether. They are fractionated directly from a Willstatter bulb; the fractions are titrated with standard alkali, and the iodine value of the residue in the bulb is determined.

The residual fatty acids from the steam distillation are extracted with ether, washed, and recovered and dried. They are then separated roughly into "solid" and "liquid" acids by a lead salt separation, usually a modification of the method of E. Twitchell (see p. 656). In T. P. Hilditch's modification (*op. cit.*) the lead salts which crystallise are recrystallised from a second portion of alcohol, solid acids are regenerated from the crystallised salts, and liquid acids from the combined alcoholic filtrates after removal of alcohol.

As an alternative to the lead-salt separation A. Grun and J. Janko (Z. deut. Oel u. Fett Ind. 1921, 41, 553, 572) propose the bromination of the fatty acids, the distillation *in vacuo* of the saturated acids from the bromo-compounds, and the recovery of the unsaturated acids by zinc and alcoholic hydrochloric acid.

The mixed fatty-acids of each group are converted to methyl esters by boiling with about twice their weight of methyl alcohol in the presence of 2% of sulphuric acid, removing any unesterified acids, which should not form more than 2-3% of the total, with dilute potassium carbonate solution from an ethereal solution of the esters, and preferably re-esterifying the acids so recovered and adding them to the main bulk of ester.

The esters are now fractionated in a vacuum

of 0.1-0.2 mm. of mercury in special distilling apparatus, various forms of which are described by T. P. Hilditch (pp. 374 *et seq.*), the preferred fractionating column being one devised by H. E. Longenecker (J.S.C.I. 1937, 56, 199T). The boiling range, saponification equivalent, and iodine value of each fraction is recorded, and the composition of each is calculated on the assumption that it contains, as already stated, two saturated and two unsaturated acids. Finally the figures are collected and referred to the original acids. Examples of the somewhat laborious calculations involved are given by Hilditch (*op. cit.*).

In cases where the unsaturated acids are not mainly of the oleic acid series with varying unsaturation but consist of groups of two homologous acids, recourse is had to catalytic hydrogenation in order to transform all acids of the liquid fraction into saturated acids before they are esterified and fractionated. In more complicated cases, where acids of varying degree of unsaturation derived from three or more homologous acids are present, the amount and/or equivalent of the saturated esters in the ester fractions is determined.

#### GLYCOBIBD SBPAKATIONS.

Methods for the quantitative determination of the fully saturated glycerides in a natural fat, and of the tri-C<sub>18</sub> glycerides by means of hydrogenation, are given by T. P. Hilditch (pp. 405, 409). The first of these, due to T. P. Hilditch and C. H. Lea (J.C.S. 1927, 3106), involves the oxidation of the fat and removal of acidic compounds produced. 100 g. of the neutralised fat are dissolved in 11. of acetone in a 3-l. round-bottomed flask, and 400 g. of finely powdered potassium permanganate are added in small amounts with vigorous shaking after each addition. Each addition is made after the liquid has ceased to boil as a result of the previous addition. The contents of the flask are then refluxed for several hours; the acetone is distilled off, last traces being removed by suction. The residue is ground and mixed with powdered sodium bisulphite (500 g.). The mixture is cautiously added to water in a basin, the flask being washed with bisulphite solution in hot water. 30% sulphuric acid is added until the mixture is slightly acid Congo Red paper, and sulphur dioxide is expelled by heat. The mixture is boiled until all manganese oxides have disappeared, cooled, and extracted with ether if the fully saturated glycerides are not present in large amount. If, however, this proportion is large, the solid layer of organic matter is removed from the top of the cooled aqueous mineral acid extract, washed free from mineral acid and salts with water, and dissolved in 10 vol. of ether; the extract is cooled to 0°. for some time, and the precipitate is removed, washed and, if necessary, added to fully saturated glycerides from the ether filtrates for purification. If the proportion is not large, the ether solution obtained as above is washed with water, and is then extracted cautiously alternately with 10% aqueous potassium carbonate solution and water. Great care is needed to avoid troublesome emulsions. When extraction

of acidic compounds is complete the solution is washed with water. The aqueous and alkaline washings are united and washed with ether, which is added to the former ether extract; The ether is removed and the residue weighed.

Should a larger percentage of mono-azela-glycerides be present than can conveniently be dealt with thus (over 25%), the ether solution of the oxidation products is first cooled > 0°. for some hours to eliminate fully saturated glycerides insoluble at this temperature, and the resulting filtrates and washings are warmed to 30°. and shaken vigorously with 50-100 ml. of saturated sodium carbonate at the same temperature. After standing for a few moments the small amount of aqueous alkaline emulsion is run off, and the nearly clear ether solution set aside at 0°. for several hours. Sodium salts of mono-azela-glycerides crystallise and are filtered off. The extraction with potassium carbonate and water is then carried off as above.

If 20% or more of fully saturated glycerides are obtained a further purification process is applied: The product is boiled in an open basin with water to which dilute potassium carbonate is added until the whole remains just alkaline to phenolphthalein. The aqueous layer is siphoned off, and the fat boiled with water several times until the latter is neutral. It is separated and weighed. The weight, may be corrected for loss in the free acidic fraction by separating the latter and determining its acid value, using this as a correcting factor.

For the determination of the tri-C<sub>18</sub> glycerides by means of hydrogenation the fat may be either completely or partially hydrogenated by a method given by T. P. Hilditch (*op. cit.*). Tristearin is then determined by crystallising repeatedly 20-50 g. of the fat from ether at 0°. or room temperature? combining the mother liquors and treating them similarly. The less soluble portions are crystallised from gradually weakening solution in ether to obtain a series of fractions, the saponification equivalents of which are determined. The composition of the fractions is calculated from these.

For the use of acetone to provide preliminary separation of the glycerides of solid or semi-solid fats, see T. P. Hilditch (*op. cit.*), J. Frankel and J. B. Brown (J. Amer. Chem. Soc. 1941, 63, 1484).

H. P. Kaufmann and O. Schmidt (Fette u. Seifen, 1940, 47, 294) use an adsorption method for the separation of fatty acids from glycerides and for separating saturated triglycerides from one another. A benzene solution is sucked slowly through a column of alumina and silica gel, when practically all the free fatty acids are found in the top part. If neutral saturated triglycerides are passed through the column, the triglycerides of high molecular weight are most strongly adsorbed on alumina and least so on silica gel.

The use of fractional crystallisation of glycerides with a view to separating individual compounds from fats is as yet of little value in analysis although the possibility has been extensively studied. The one exception to this rule lies in the use of crystallisation of lard from ether as a means of detecting adultera-

tion, particularly the addition of beef fat or hydrogenated oils (v. Vol. VII, 1926, c).

Belfield and Delafontaine in 1883 based *m* test on a method of C. Husson (J. Pharm. Chim. 1878, i; iv<sup>^</sup> 27, 100), dissolving the fat in ether and examining the crystals which separate under the microscope. In various forms and with various extensions this test survives, notably in the British Pharmacopoeia, 1932, where the modification followed is mainly that of Emery (U.S. Animal Industry Circ. 132). The B.P. test is as follows: Place in a 25-ml. stoppered cylinder 5 g. of melted lard; add warm ether to the 25 ml. mark. Stopper securely and shake until the lard is completely dissolved. Allow the cylinder to stand at a temperature of 16-20°o. for 18 hours. Decant the clear solution from the crystals, and wash them with three portions of 4 ml. of colli ether, avoiding breaking up the crystals during the first two washings. Agitate the crystals with the third portion of ether, and transfer to a small filter. Wash with successive small quantities of ether until 16-20 ml. have been used. Remove the last trace of ether by suction through the stem of the funnel. Allow the deposit to dry. Pulverise the crystals, and determine their melting-point in a closed 1-mm. tube. The melting-point must not be lower than 63°o. for pure lard, and is usually higher than 63°o. If below 63°o. the presence of beef or hardened fats is indicated.

It may be noted that crystals sometimes fail to appear in this test, and in this case it is presumed that no hard fat such as beef fat or hardened oils is present.

An investigation of the saturated glyceride of lard and tallow obtained by repeated fractional crystallisation, A. Bömer (Z. Unters. Nahr. u. Genussm. 1913, 26, 559) concluded that the glyceride separated was a palmito-distearin differing from a similar compound derived from tallow in its structural configuration. The difference is reflected in the crystalline form of the deposit from ether obtained with lard and tallow crystals being usually chisel-shaped with oblique ends, whilst those from tallow are needle-like and curved, and are usually arranged in plumose tufts. The form of the deposit obtained from mixtures of lard and tallow has been investigated by R. W. Sutton, (Analyst, 1940, 65, 623) who have reviewed the literature of the detection of adulteration of lard in detail. These authors find that forms of crystal transitional between the lard and tallow forms are yielded from the fats, but this observation has not been noted in the literature. It is known that the form of crystal is given by pure, dried, under certain conditions, and K. A. Williams

found that when these are resolved to the di&M form if they are rolled over through a right-angle, whilst the treatment, it is evident that the apparent plumose form is due to their point of retracted growth from a common point. The British Pharmacopoeia test given above has been extended by A. Bömer (Z. Unters. Nahr. u. Genussm. 1913, 26, 559) to include

determination of the melting-point of fatty acids prepared from the crystals deposited from ether. The difference between this figure and the melting-point of the crystals is about 5.2°c. for pure lards and ranges from 0.1° to 2.6°o. for beef and mutton fats. An arbitrary figure obtained by adding twice this difference to the melting-point of the crystals has been proposed by H. Sprinkmeier and A. Diedrichs (*ibid.* 1914, 27, 571) as a criterion of purity. J. Kerr (J. Assoc. Off. Agric. Chem. 1920, 4, 195) proposed the substitution of acetone for ether as solvent for the crystallisation, using a temperature of 30:2°o. and calculates the arbitrary figure before suggested, suggesting a limit of 73 for pure lard. This test appears in a form put forward by an American Chemical Society Committee (Ind. Eng. Chem. [Anal.], 1940, 12, 379) and is abstracted in detail in Analyst, 1940, 65, 508. The method has been criticised, as has also the British Pharmacopoeia method, by K. A. Williams (*ibid.* 1940, 65, 596), who states that the limits of temperature laid down in each test for the crystallisation are not sufficiently close, and permit of considerable divergence in the results of different operators.

#### COLOUR TESTS.

Many colour tests for particular oils have been proposed from time to time, but few of them have survived. Nevertheless a few are worthy of note and are still regularly used; they are as follows:

**G. Halphen's Test for Cottonseed Oil** (J. Pharm. Chim. 1894, [v], 30, 241; 1897, [vi], 6, 391; see also VoIII, 411c) depends on the development of a rich red colour when cottonseed oil is heated with amyl alcohol and carbon disulphide containing a trace of sulphur. This reaction is given also by kapok and baobab oils; if the cottonseed oil has been subjected to heat, the reaction is lessened in proportion to the degree and time of heating. Unheated oils give the reaction quite strongly even if they form only 1% of a mixture of cottonseed oil with indifferent oil.

About 2-5 ml. of the oil to be tested is mixed in a strong tube with equal volumes of amyl alcohol and a 1% solution of sulphur in carbon disulphide. The tube is closed and the stopper firmly tied down. The tube and contents are placed in a boiling-water bath for 30 minutes; it may be noted that tubes occasionally explode, and due precautions should be taken in view of the extreme inflammability of carbon disulphide. Development of the characteristic colour indicates the presence of cottonseed, kapok, or baobab oils; no attempt to estimate the proportion of these oils present should be made from the intensity of the colour for the reasons indicated above.

**The Baudouin Test for Sesame Oil**, claimed by J. Lewkowitsch to be due to Camoin, is probably the most satisfactory of the oil colour tests. It consists in the development of a rose-red colour by the action of a mixture of concentrated hydrochloric acid and cane sugar on the oil. Alternatively a mixture of the acid with furfural may be used (V. Villavecchia and O. de Fabris, J.S.C.T. 1893, 12, 67; 1894, 13,

69), but experience has proved that it leads at times to positive results in cases where sesame\* oil is absent. The colour-producing substance is strongly resistant to heat and because of this and the ease of operation of the test many countries, especially on the Continent of Europe, have made mandatory the addition of small quantities of sesame<sup>1</sup> oil to margarine. Certain olive oils grown chiefly in North Africa tend to give a slight pink reaction in the test, and this may be dealt with in the manner described below.

The British Standard Test based on the reaction (B.S. No. 656, 1936) is as follows: Shake 2 ml. of the oil with 1 ml. of hydrochloric acid (p 1-16), containing 1% w/v of sucrose, and allow to stand for 5 minutes.

In the case of olive oil which may be suspected of containing sesame<sup>1</sup> oil the British Standard Test (B.S. No. 630, 1935) requires 5 ml. of the oil to be shaken in a flask with 5 ml. of a mixture of 9 vol. of alcohol (90%) and 1 vol. of ammonium hydroxide solution (p 0-88) and heated on a water bath until free from alcohol and ammonia. The above test is then carried out on the product.

A similar red colour is produced by the action of hydrochloric acid alone on fats dyed with certain dyestuffs, and may mask completely the colour due to sesame<sup>1</sup> oil in the above test. Provision is made for this in the Danish Regulations governing the manufacture of and trade in margarine, etc., of May 30, 1925, which prescribe the following test.

Mix 0.5 ml. of the melted and filtered margarine fat (which must be freed from aniline dyes, as below) with 9.5 ml. of arachis oil or cottonseed oil, which themselves give no red colour in the test. Shake the mixture thoroughly for 1 minute in a test tube 18 mm. in diameter and about 180 mm. long with 10 ml. of fuming hydrochloric acid of p 1-19 and with 0.1 ml. of a 2% alcoholic solution of furfural (2 parts by volume mixed with 98 parts of absolute alcohol); the mixture must have a temperature of 40°C. When the mixture has stood in the test tube for 15 minutes, the acid layer which settles under the fatty layer must show a red colour of a tint not fainter than that on the colour plate which the Minister of Agriculture has caused to be produced. (The colour plate in the writer's possession shows a colour corresponding to a Lovibond reading of 20 red, 0.8 yellow.)— If a red colour appears when the fat is shaken with hydrochloric acid alone, due to the presence of aniline dyes, the following procedure must be adopted: 10 ml. of the fat are shaken for 30 seconds in a small separating funnel with 10 ml. of hydrochloric acid, p 1-125. The red layer of hydrochloric acid which collects below when the mixture has stood for some time is run out, and another 10 ml. of hydrochloric acid of the same density are added. The mixture is again shaken for 30 seconds. If the hydrochloric acid which separates out is still coloured red, the treatment of the fat is repeated in the same way until the hydrochloric acid remains colourless. No higher temperature must be used than is necessary just to keep the fat melted. After complete removal of the hydrochloric acid the test is made in the manner described above.

Bieber's Test for the adulteration of Almond Oil is used in the examination of oils suspected of being adulterated with peach-kernel or apricot-kernel oils. It is carried out by agitating 5 vol. of the oil with 1 vol. of a freshly-prepared mixture of equal weights of water, sulphuric acid, and fuming nitric acid. Pure almond oil does not change in colour appreciably, apricot-kernel oil gives a pronounced pink colour, especially if fresh, and peach-kernel oil gives a fainter pink colour. By this means 40-50% of apricot kernel may be detected in admixture with almond oil, but the test is uncertain for any smaller proportion.

The Liebermann-Storch Test for Rosin in oils is usually made on a specimen of fatty acids prepared from the oil. A small quantity (up to 0.5 g.) of these is dissolved in acetic anhydride with gentle heat and allowed to cool. Sulphuric acid (p 1-53) is then carefully run on to the solution. In the presence of rosin acids a fugitive reddish-violet colour is produced. Almost all fatty acids fail to give any colour in the test, but a notable exception is tung oil, and it must also be remembered that cholesterol reacts. This fact is made use of in a modification of the Liebermann-Burchardt test adapted for the colorimetric determination of cholesterol by K. A. Williams (unpublished)! A quantity of material containing up to 0.12 mg. of cholesterol is dissolved in chloroform and made up to 4 ml. therewith. 1 ml. of acetic anhydride and 0.1 ml. of concentrated sulphuric acid are added and the green colour due to cholesterol allowed to develop. A 1-cm. cell is filled with the liquid and a second 1-cm. cell filled with chloroform and the reagents is used as a blank, the absorption of light of wavelength about 640 m $\mu$  is measured visually or photometrically, and the weight of cholesterol present derived from a standardisation curve.

A further modification of the test has been applied by J. Fitelson for the detection of Teaseed Oil in admixture with olive oil (J. Assoc. Off. Agric. Chem. 1936, 19, 493). A mixture of 0.8 ml. of acetic anhydride, 1.5 ml. of chloroform, and 0.2 ml. of sulphuric acid is cooled in a test tube to 5°C. Seven drops of the oil, weighing ca. 0.228 g., are added by means of a tube of 4 mm. external and 2 mm. internal diameter. The contents of the tube are mixed and, if cloudy, acetic anhydride is added drop by drop until they clear. The mixture is allowed to stand at 5°C. for 5 minutes and 10 ml. of anhydrous ether are added and the whole is immediately mixed. Teaseed oil gives a marked red colour within a minute, the colour afterwards fading. Olive oils from certain sources give a fleeting pink colour and this fact must be allowed for in judging whether such an oil is adulterated.

The following modification is suggested by the Olive-oil Committee of the American Oil Chemists Society (Oil and Soap, 1941, 18, 187) as an improvement. Saponify a mixture of 5 g. of the oil with 5 g. of a colourless mineral oil by boiling for 10-15 minutes with 6 ml. of 50% potassium hydroxide solution in about 30 ml. of alcohol. Pour the liquid into a separating funnel, add an equal volume of water, shake and

allow to separate. Draw off and reject the lower soap solution. Wash the oily layer several times with water, dry over anhydrous sodium sulphate and filter. Use seven drops of the product for the Fitelstn test as above. (See also W. H. Dickhart, Amer. J/Pharm. 1940, 112, 371?)

Blue Value.—Cod-liver oils produce a fleeting blue colour when mixed in chloroform solution with a solution of antimony trichloride in chloroform and the depth of colour produced is related to the amount of vitamin-A in the oil. A more pronounced reaction is obtained from unsaponifiable matter produced from the oil than from the equivalent weight of the oil itself owing to the masking effect of glycerides, etc. There is reason to believe that in one form or another the test gives useful information regarding the vitamin-4 content of a cod-liver oil, but it has not received official recognition as a method for its determination. A "blue value" was included in the British Pharmacopoeia, 1932, p. 596, and this was deleted by the Second Addendum, 1939, p. 35. A quantitative method is described by J. C. Drummond and T/P. (U.S. Pharm. J. (p. 31), and is essentially the test of H. Carr and E. A. Price (Biochem J. 1926, 497). The blue value is expressed as the colour in Eovibond blue units developed in oil seconds and measured in a 1-cm. cell on mixing 2 ml. of the antimony chloride reagent (a saturated solution, in anhydrous chloroform) with 0.2 ml. of a 10% solution of the oil in chloroform. About 1 g. of the oil is accurately weighed and dissolved in 10 ml. of redistilled chloroform. A 0.2 ml. portion of this solution is placed in a 1 cm. cell, and 3 ml. of a 30% solution of antimony trichloride in chloroform is added. The colour is observed after the addition of the antimony chloride, was begun the colour is matched in a Rosenheim-Schuster tintometer. At least four separate estimations on 0.2 ml. are made, and then, depending on the chromogenic power of the oil, a series of colour estimations is made on a greater or lesser concentration of the oil. The colour produced is more or less directly proportional to the amount of vitamin A in the oil. The results are plotted on a graph, and the value of the solution is read off if the value is 1.8 to 1.6; otherwise it is necessary to re-prepare the non-saponifiable matter and re-test against oxidation and carry out the dilutions of that material.

The test was first described by N. Evers (Quart. J. Pharm. 1929, 9, 249).

addition to margarine and butter, the Health Department in this country (Public Health Regulations, etc., in Food) Regulation, 1925, No. 775, prohibited the use of certain colouring matters in foods including some metallic compounds and five coal tar colours. Methods for testing these colours are given by Nicholls (Anal. J. 1927, 52, 585). Generally speaking, any be taken into account or azo-dyes. E. R. detection.

**Annatto.**—Shake a few grams of the clear melted and filtered fat with 5 ml. of warm 10% sodium hydroxide solution. Pour on a wet filter and keep warm until most of the water has passed through. Then pour the melted fat off the paper and wash the latter gently with cold water. In the presence of annatto, it will be stained a reddish-yellow of an intensity dependent on the quantity of annatto present. If the stain be very slight or indefinite, dry the paper and moisten it with 1 drop of a 6% solution of citric acid, when a pink colour will develop in presence of traces of annatto.

**Azo-dyes.**—Place about 2 g. of the melted and filtered fat in each of two test tubes together with 5 ml. of light petroleum to prevent solidification. To one test tube add 1 ml. of hydrochloric acid (1:3), and to the other 1 ml. of 10% potassium hydroxide solution; shake the tubes thoroughly and allow to stand. If an azo-dye is present the lower layer in the hydrochloric acid tube will be pink, and in the other tube colourless. In the case of annatto, the acid layer will remain colourless, while the alkaline layer, or an intermediate layer lying between the fat and alkali, will be coloured bright yellow. As mixtures of annatto and azo-dyes are sold for colouring purposes, both reactions may occur in the same fat.

If no azo-dye colour is obtained, as may happen with certain dyes, mix 1 ml. of the melted fat with 1 ml. of a mixture of 1 part of concentrated sulphuric acid and 4 parts of glacial acetic acid, and heat nearly to boiling with constant shaking. The acid solution, on settling out, will be pink or reddish in the presence of azo-dyes, practically no colour being produced in their absence.

POLYMERISATION TESTS.

A number of tests for the purity of tung oil have been based on the fact that it polymerises when heated to temperatures between 250-300° to a stiff jelly-like mass. C. A. Browne (Chem. News, 1906, 106, 14; J.S.C.I. 1912, 31, 731) places 5 ml. of the oil in a test tube, 16 cm. by 15 mm., closed by a cork so perforated that a glass rod, 3 mm. diam., can be moved up and down freely in the tube. A copper beaker, 12 cm. high, 6 cm. internal diam., filled with oil to a height of 5 cm., is heated until the oil has a temperature of 293° and the temperature is then rising slowly. The test tube is then introduced into the beaker and fixed with its bottom 1.5 cm. from the bottom of the beaker. A thermometer, 30 cm. long and graduated from 100° to 400°c. is suspended with its lower end 1.5 cm. from the bottom of the beaker; its readings are corrected for the exposed stem. The time is noted on its introduction and the source of heat is removed for about 45 seconds and then re-applied. In less than 2 minutes the temperature must have fallen to 282° and it is kept constant at that point. After 9 minutes, the glass rod is raised at intervals of half a minute and the time is noted when the gelatinised oil first sets firmly. The American Society for Testing Materials suggested in 1925 a tentative upper limit of 12 minutes for this time for pure tung oil.

The British Standard for ung oil (B.S. No. 391, 1936) includes a mandatory test on similar lines in which a test tube of very similar size is used in an oil bath, 12 cm. by 16 cm. high, and containing 500 ml. of oil such as soya-bean, cottonseed, or medicinal paraffin oil or carnauba wax. The test tube is inserted in the oil when the latter is at 275-277°C, and is fixed with its bottom 1.5 cm. from the bottom of the beaker, and level with the lower end of the thermometer by which the temperature of the bath is measured. The bath is kept at 276±1°C. for 12 minutes, after which a specified rod in the oil is raised at 15 second intervals. The time is noted when the oil becomes so stiff that movement of the rod lifts the test tube. In the case of pure tung oil the jelly is required to be firm, non-sticky, and capable of being cut cleanly with a sharp knife. The oil is required to gel within 12 minutes or a period not exceeding that taken by an agreed reference sample. Experience of the test has shown that few pure oils gel within 12 minutes by this test, and that in order to comply with this requirement it will be necessary for the standard temperature to be raised.

The Worstall Test (J.S.C.I. 1912, 31, 731) specifies a somewhat similar procedure in which the oil is heated in a shallow iron dish and stirred constantly with a thermometer at 285°C. until gelation takes place, the time for this to occur being noted. E. R. Bolton and K. A. Williams (Analyst, 1926, 51, 335; 1930, 65, 360, 366) agree with A. C. Chapman (*ibid.*, 1912, 37, 543) that the test is unsatisfactory in its original form and have proposed the following modification. About 150 g. of the oil, contained in a stout aluminium beaker, exactly 3 in. in diameter and 4 in. in height, are heated by a Bunsen burner so as to reach a temperature of 285°C. in 4 minutes, the oil being vigorously stirred by means of the thermometer during the heating. A stop watch is started as soon as the temperature reaches 285°C. and the temperature of the oil is thereafter maintained as nearly as possible at 285°C., stirring being continued all the time. The approach of polymerisation is first indicated by a thickening of the oil, and this is followed by the setting of the oil to a jelly. The time is noted when, just prior to complete solidification, the oil just fails to drop from the thermometer if this is raised from the bath. Genuine tung oils reach this point in from 8-8.5 minutes. The temperature of the oil is maintained above 280°C. for about 1 minute after solidification has taken place and the vessel and contents are then allowed to cool spontaneously. A stem correction must be applied if a long-stemmed thermometer is used, since a variation of 3°C. from the standard temperature throughout the polymerisation will cause a difference of as much as 3 minutes in the time of polymerisation with some specimens of tung oil. A genuine tung oil produces a dry, firm gel of pale yellow colour and characteristic appearance and texture.

These authors extend this test to provide a means of determining the proportions of polymerisable and unpolymerisable matter in tung oil thus. A portion of approximately 2 g. is taken from the centre of the polymerised mass

when cold, cut into pieces and weighed into a mortar to which are added about 3 g. of dry, fat-free sand and 2 ml. of light petroleum (b.p. 4(M), 10°C.). After standing for a few minutes the mixture in the mortar is ground until the solvent has for the most part evaporated, and the sand and gel are thoroughly mixed. The mixture is transferred to an extractor, the mortar being well washed into this with light petroleum, and extraction being carried out in the usual manner. Tung oils are found to give an extract of 28% of the normal commercial quality, with a variation not exceeding ±2%. The proportion of polymerisable matter is found by subtracting the percentage of extract from 100. It is claimed that the test will detect adulteration of tung oil if 5% of adulterant is present. A similar test (in which 5 ml. of tung oil are polymerised in a test tube immersed in an oil bath maintained at 290°C. for 20 minutes longer than the time required to cause solidification, and an extraction is carried out on the resulting gel) is proposed as a subordinate test in E.S. No. 391, 1936, to which reference should be made.

#### VITAMINS.

Vitamins A, D, and E occur in various oils and fats and a very considerable volume of work has been published dealing with their estimation. Generally speaking the preferred methods in each case are biological ones, but in the case of vitamin A results of biological testing are closely paralleled by those of a spectrophotometric method, while in the case of vitamin A chemical tests are still being sought and tested. The "blue" value of cod-liver oils, believed to depend on the vitamin A content of the oil, has not received official recognition in this country as a measure of the vitamin content (see p. 73a).

The British Pharmacopoeia, 1932, and Addenda, 1936 and 1940, lay down both a standard biological test for vitamin A and a standard alternative spectrophotometric test applicable to cod-liver oils coming within the scope of the Pharmacopoeia; and similar tests have been adopted as British Standards in specifications for Controlled Cod-Liver Oil for Animal Feeding Purposes (B.S. No. 910, 1940) and Vitamins A and D in Oil for Animal Feeding Purposes (B.S. No. 909, 1940). The B.P., and B.S. No. 910, require 600 International Units of vitamin J. to be present in the oils to which they refer; B.S. 909 requires 1,000 units.

Similarly the British Pharmacopoeia, 1932, and the Second Addendum, 1940, lay down a standard test for the estimation of vitamin D applicable to oils coming within the scope of the Pharmacopoeia; and a similar test appears in the two British Standards mentioned above. The B.P., and B.S. No. 910, require 85 International Units of vitamin D to be present in cold-liver oils; B.S. No. 909 requires 100 units.

In the case of the British Standards there is a further requirement that if the oil under review is intended for use in the feeding of poultry it must be accompanied by a guarantee that the amount of vitamin D declared is fully effective for poultry when tested by the chick test (B.S. No. 911). Vitamin D derived from the cod (*Oadus morrhua*) is considered to be fully effective.

tive in this respect, but if derived from other members of the genus *Oadus*, this is not necessarily so.

For the assay of vitamin-<sup>A</sup> and vitamin-<sup>D</sup> in butter, see B. J. Morgan (Biochem. J. 1934, 28, 1178; 1932, 26, 1144) and H.T.C. Bechdel and C. A. Hoppert (J. Nutrition, 1936, 11, 537); for the assay of vitamin-<sup>B</sup> in margarine, see J. R. Edistery (Analyst, 1940, 65, 484); for the assay of vitamin-<sup>B</sup> in margarine, see N. H. Gridge-man, H. Lees, and H. Wilkinson (*ibid.* 1940, 65, 493); the biological assay of vitamin-<sup>D</sup> has been reviewed by A. Z. Baker and M. D. Wright (*ibid.* 1940, 65, 326); for a note on the occurrence of vitamin-<sup>B</sup> in certain oils, see T. M. Haines and J. C. Drummond (*ibid.* 1938, 63, 338).

The assay of vitamin-<sup>A</sup> has been reviewed by A. L. Bacharach (Biochim. J. 1938, 32, 2017) and colour tests are proposed for its estimation (S. J. Merie and C. J. Inge (Rec. trav. chim. 1938, 67, 1851) and M. Farber and P. E. Mayer (Helv. Chim. Acta, 1938, 21, 240). The possibility of separating this vitamin by chromatographic processes put forward by A. R. Moss and J. C. Drummond (Biochem. J. 1938, 82, 1953) and A. Emmerie and C. Engle (Rec. trav. chim. 1938, 63, 283).

#### RANCIDITY.

The term "rancidity" is used both in the general sense of indicating deterioration in flavour or, specifically to denote the hydrolytic changes occurring in fats and arising from bacterial and enzymic action. In the latter sense it may be contrasted with the term "stinkiness" indicating oxidation. C. H. Leitch (P. 36), in a comprehensive monograph on the subject, classifies the possible causes of rancidity under several headings; absorption of oxygen, action of enzymes, action of micro-organisms and atmospheric oxidation, on the impurities for deterioration are based on the smell, and are properly classified into three panels. Suchstein has the advantages of requiring a wider degree of skill, of being analytical, quantitative, and of failing to deal satisfactorily with the cases of pronounced rancidity. The value of the iodine value and rise in refractive index and usually a rise in chemical viscosity. Ranges are of such small magnitude that assessing

The production of a "Perfume" rancidity in fats containing re and acid proportions of ketone and acid formation. Such ketones result from the action of micro-organisms, particularly moulds, and are tested for by the method of K. Täufel and H. Thaler (Chem.-Ztg. 1936, 56, 265). Between 25 and 30 ml. of water are still from 160 ml. contain in a 200-ml. glass-stoppered flask fitted with a short condenser and receive in a 50-ml. glass-stoppered

tube; 0.4 ml. of each aldehyde, purified through the bisulphite compound, are added and the mixture is shaken vigorously. The tube is centrifuged and, after settling, all but 4 ml. of the supernatant aqueous liquid is poured off. The residue is again shaken and 2 ml. of concentrated sulphuric acid are dropped into the emulsion. The mixture is shaken and then allowed to stand. The upper layer should not be more than pale yellow or pale pink. 5 to 10 g. of the oil to be tested are added to the remaining water in the distilling flask by means of a long-stemmed funnel, and 25-30 ml. again distilled. The distillate is tested with aldehyde and acid as before. In the presence of ketones the aldehyde layer is coloured pink to red. The test will detect 1 part of ketone per million of oil. It has been modified by H. Schmalfluss, H. Werner, and A. Gehrke (Marp. Indus. 1932, 25, 215) who allow for the estimation of the red colour in a tintometer.

Oxidative Rancidity has been the subject of much investigation and many tests have been proposed for its detection, most of them being quantitative. In cases where oxidation has proceeded to a considerable extent, the method of W. Fahrion (Chem. Umschau Fette, 1920, 16, 158) may be used to determine oxidised fatty acids. 3 g. of the oil or fat are saponified in the usual manner, and alcohol is removed. The soap is dissolved in 50-70 ml. of hot water and transferred to a separating funnel. When cooled, 100 ml. of light petroleum are added. The solution is acidified with hydrochloric acid, shaken, and allowed to stand overnight. The aqueous layer is run off, and the petroleum solution filtered, the insoluble oxidised acids being transferred to the filter. There they are washed with light petroleum and then dissolved in warm alcohol or ether. The solution is evaporated and the acids dried at not over 95°C. and weighed.

For the determination of water-soluble oxidisable impurities, R. H. Kerr (J. Ind. Eng. Chem. 1918, 10, 471) has modified the process of G. Issoglio (Annali Chim. Appl. 1916, 1, 18), producing a test of great value for estimating the relative keeping properties of fats, especially of edible animal fats, e.g., beef tallow. 25 g. of the fat are heated with 100 ml. of distilled water at 100°C. for 2 hours with constant shaking. The aqueous portion is separated by filtration through a wet filter paper and the filtrate made up to 100 ml. with water. 10 ml. of the filtrate are boiled for 5 minutes with 50 ml. of 0.01N. potassium permanganate solution; the contents of the flask are cooled, 10 ml. of sulphuric acid (1:5) and 50 ml. of 0.01N. oxalic acid are added, and the solution is heated and titrated with 0.01N. permanganate solution. The oxidisability value is the number of milligrams of oxygen required to oxidise the water-soluble matter from 100 g. of the fat. The test, which determines mainly the strongly odorous lower aldehydes, has been further commented on by L. H. Lampitt and N. D. Sylvester (Biochem. J. 1936, 30, 2237).

The Kreis Reaction, depending on the formation of a red colour when a rancid fat is shaken with hydrochloric acid and an ethereal solution of phloroglucinol, is due to the presence



of an acetal of epihydrinaldehyde. Both this test and that due to Schiff (the general reaction for aldehydes) are described fully by C. H. Lea (Rancidity in Edible Fats, Food Investigation Special Report No. 46, pp. 98, 102).

The most important test for oxidative rancidity, the estimation of Peroxide Oxygen, has been proposed in many forms. It is usually applied in the simplified form of C. H. Lea (p. 109). 1 g. of the oil or fat is weighed into a Pyrex test tube, approximately 1 g. of powdered potassium iodide and 20 ml. of glacial acetic acid-carbon tetrachloride mixture (2:1 by volume) added, and the liquid heated to boiling over a small flame impinging on the bottom of the tube. Boiling is continued for 30 seconds, and the tube is cooled under the tap. The contents are poured into 30 mL. of water and titrated with 0.002N. sodium thio-sulphate, starch solution being used as indicator. The titration should be corrected by the result of a blank test. The number of millilitres of 0.002N. thiosulphate thus obtained represents the number of millimoles (2 milliequivalents) of peroxide per kilogram of fat.

Such tests as have been described indicate in general only the state of rancidity prevailing in the fat at the time of testing; though it is true that deductions as to the probable useful life of the fat may be made in some instances if the source of the fat is known and its general behaviour has been studied. Since such deductions may be misleading, various tests have been devised to obtain definite information. These tests are based on induced oxidation. By exposure of the fat to temperatures of from 40-100°C. in an atmosphere of oxygen, or by the action of light, or by catalysis by traces of metallic salts, the development of rancidity is reduced from months to hours. In all such methods extremely careful control of the conditions of oxidation is obviously necessary. For details of typical methods reference may be made to papers by D. H. Wheeler (Oil and Soap, 1932, 9, 89), A. E. King, H. L. Roschen, and W. H. Irwin (*ibid.* 1933, 10, 105), L. H. Lampitt, N. D. Sylvester, and P. Bilham (Biochem. J. 1935, 29, 1167), and the American Oil Chemists Society (Oil and Soap, 1935, 12, 187).

**Mackey Test.**—A further example of the use of induced oxidation for the assessment of the value of an oil occurs in the use of the Mackey test, or its modifications, for estimating the liability of cloth oils such as olive oil to heat spontaneously when spread on textile fibres. Fibres such as wool when oiled with semi-drying or drying oils almost invariably heat on storage and the risk of fire would be considerable if they were used commercially. Restrictions are therefore applied by Fire Insurance Companies to the types of oil to be used.

The original apparatus of Mackey and its method of use are described by J. Lewkowitsch and G. Warburton (p. 105). The apparatus consists essentially of an air bath provided with a lid through which pass two tubes for the purpose of inducing a current of air to circulate in the bath, and surrounded by a water jacket. A wire-gauze cylinder rests in the air bath and in this is placed a light roll of cotton wool oiled with

the oil under test. The water in the jacket is boiled throughout the test, and the temperature of the oiled wool in the cylinder is noted at intervals. An oil is regarded as dangerous if its temperature rises over 100°C. in 1 hour, and very dangerous if 200°C. is reached in 1 hour. 7 g. of cotton wool is used in the test and this is oiled with 14 g. of oil, care being taken that the oil is thoroughly and evenly distributed over the wool. The Fire Offices Committee of 65 Watling Street, London, now specifies the use of the Firth modification of the Mackey Tester in which a better air circulation is secured than in the original tester, and prescribes more precise directions for its operation. Similarly, W. Garner and W. Leach (Analyst, 1936, 61, 337) suggested an improved technique for the original tester. W. Garner (*ibid.* 1936, 61, 19) deals with the effect of traces of catalysts, including iron soaps, which accelerate the heating of olive oils in the test, and W. Garner and M. Elsworth (*ibid.* 1940, 65, 347) have investigated the relation of the results of the Mackey test and the rate of accumulation of peroxides in the oil.

#### ROSIN.

Rosin is found in admixture with fatty matter, usually in soaps. It may be determined by the Twitchell method described by E. R. Bolton (p. 10) in which the fatty acids and rosin are submitted to the action of hydrogen chloride in alcoholic solution, when the fatty acids esterify and the rosin remains unesterified and is subsequently titrated with standard alkali. The more usual method, however, is now that of McNichol (J.S.C.I. 1921, 40, 124T), which has been standardised by the Analytical Methods Committee of the Society of Public Analysts, etc. (Analyst, 1937, 62, 868) and is conducted by separating the total fatty matter from about 5 g. of soap by dissolving in hot water, acidifying with dilute sulphuric acid, cooling, and washing the cake of fatty matter with water until the aqueous washings are free from acidity, or by extracting the fatty matter with ether from acid solution. 2 g. of the fatty matter are weighed into a 150 ml. flask, dissolved in 20 ml. of a solution of 40 g. of naphthalene-2-sulphonilic acid in 1 l. of pure dry methyl alcohol, and the mixture is boiled gently under a reflux condenser for 30 minutes, small pieces of pot being added to ensure regular ebullition. A blank test is carried out at the same time with 20 ml. of the reagent alone. The contents of the two flasks are cooled and titrated with 0.2N. alcoholic potassium hydroxide solution, using 0.5 ml. of 0.5% alcoholic phenolphthalein AS indicator. The resin acids are calculated as a percentage of the total fatty matter on the assumption that 1 ml. of the alkali solution is equivalent to 0.0652 g. of resin acids, and 1% is subtracted from the result so obtained. It may be assumed that rosin contains 92% of resin acids.

#### PHYSICAL TESTS.

##### MELTING-POINT.

Fats, being complex mixtures of glycerides, have no sharp melting-points but melt gradually over a range of temperature varying in extent



from fat to fat. *hven* pure solid triglycerides, such as trisearin, exist in four different crystalline forms each having different melting characteristics. It is therefore not surprising that many tests have been proposed for the determination of various points at which melting reaches some definite stage. For example, in Pool's method a thin film of melted fat is formed on the bulb of a thermometer and allowed to solidify; after a day or two the thermometer is fixed centrally in a test tube with its bulb near the bottom, and the tube is gently warmed until a drop of liquid oil forms; the temperature at which this occurs being taken as the melting-point. An improvement of this method, due to L. Ubbelohde (*Z. angew. Chem.* 1905, 18, 1220), forms British Standard No. 894, 1940; in this, a small amount of the fat set under agreed conditions, is filled into a glass cup having an orifice in its bottom and of specified dimensions, and the thermometer lowered so that the bulb is exposed centrally in the fat. The thermometer and cup are suspended in a boiling tube, which in turn is damped in a beaker filled with water. The beaker is heated and stirred so that the temperature of the fat rises 1°C. per minute and the float and drift points are recorded, the former being the temperature at which the fat forms an approximately hemispherical protuberance at the orifice of the cup, and the latter that at which the first drop falls from it.

A similar method, for use with hydnocarpus oil, soft paraffin, and wool fat is given in the *Pharm. J.* 1932, p. 528.

More commonly used is the method of Le Sueur and Crossley (*J.S.C.I.* 1898, 17, 988) or one of its modifications in which a short length of capillary tube of internal diameter and 7 mm. length having a diameter of 0.5 mm. is fastened to the thermometer by means of rubber bands and placed in a beaker of water, which is heated gradually. In the original test the point at which the fat is seen to rise in the capillary was taken as the melting-point. Later both the incipient point at which the liquid fat appeared completely melted (complete point) were recorded. A more precise and satisfactory form of the method was given by B. H. D. and T. Thornley (*Analyst*, 1921, 46, 180), the chief improvement being the use of a hydrostatic pressure applied to the thread of fat.

Discrepancies, occur between the results of observers using the capillary tube method, especially in the judgment of the incipient melting-point, and to overcome these K. A. Williams has devised (*Ibid.* 1941, 66, 3) a method in which incipient and complete points are measured photoelectrically.

The fact that melting of a fat begins at temperatures considerably below the point at which it first becomes visible was established by K. A. Williams (1938) who has investigated the change of density of a fat as the temperature of the fat is gradually raised. In this method the density is determined from the apparent weight of about 5 g. contained in a small glass

bell suspended from the arm of a balance and immersed in a beaker of water. The densities obtained are claimed to be accurate to within 0.0002 units, and it is shown that for a given fat the rate of change of density per unit rise in temperature is steady and small up to a temperature taken to indicate the start of melting; it then changes abruptly to a much higher, but still steady, rate which persists until melting is complete, and then changes again abruptly to a third steady rate, also small.

The first and third rates represent the density change per 1° for solid and liquid fat, respectively, the intermediate rate that for the fat while it is actually melting. Plotting of densities against temperature leads to reproducible melting-points, and it is suggested that the rate of change of density during melting—which varies considerably for different fats—may prove to be an analytical constant of value in characterising fats.

The dilatation of fats on melting is also used as a criterion of their suitability for blending in margarine fats; volumetric methods for the study of this factor are given by W. Norman (*Chem. Umschau Fette*, 1931, 88, 17) and Kai Hofgaard (*Dilatometriske Fedtstof-Under-80gelsel*, 1938).

#### SOLIDIFYING POINT AND TITRE TEST.

When melted fats are allowed to cool spontaneously, their temperature first falls to a minimum value and then rises somewhat during a period when solid material separates and latent heat is released. A maximum temperature is reached at a point where radiation effects balance the diminishing evolution of latent heat. After this the temperature once again falls. The highest temperature reached during the second stage of the cooling is known as the solidifying point of the fat. It is usually determined by placing 25-30 g. of the melted fat in a beaker or tube about 1½ in. in diameter and 3-6 in. deep in which a thermometer is supported by a cork with its bulb immersed in the liquid; as soon as a tendency to solidify is shown by the spontaneous cooling of the fat the tube or beaker is supported by means of a cork in a wide-mouthed bottle in such a way that it is surrounded by an insulating layer of air at room temperature. The fat is then stirred gently with the thermometer, care being taken that the latter does not touch the sides of the tube. The temperature is observed, and the highest point to which it rises is noted as the solidifying point. With some fats the rise in temperature is large and definite, with others it may be small, or the thermometer may remain stationary for a short time without any rise being apparent; in such cases the stationary temperature is taken as the solidifying point.

A corresponding sequence of temperature changes is shown by fatty acids on solidification. Here the rise is usually slight, but it is also very definitely marked; the highest point reached is known as the Titre Point. It is generally obtained by Dalican's method, similar to that described above, but using a more standardised procedure. The method is given by E. R. Bolton (p. 23) thus: 60 g. of the fat are

placed in a 300 ml. flask with about 15 g. of stick sodium hydroxide and 100 ml. of 95% alcohol. The flask is connected to a reflux condenser and heated in a boiling-water bath with constant shaking until saponification is complete. The alcohol is rapidly boiled off and the soap dissolved in not less than 500 ml. of hot water. To the hot solution are added 1 or 2 drops of Methyl Orange and somewhat more hydrochloric acid than is required to render the solution permanently pink. The vessel is kept in boiling water until the layer of fatty acids becomes quite clear. The water is siphoned off as completely as possible, and the residual fatty acids are filtered through dry, soft paper until a bright, clear filtrate results. Their solidifying point is determined in a tube, 1 j x 5 in., supported in a bottle 10 cm. wide and 13 cm. high, by means of a cork, and so fixed that the whole of the fatty acids are within the bottle. A thermometer, with mercury bulb 3 cm. long and 6 mm. wide, is inserted centrally in the fatty acids. Immediately crystals form at the sides and base of the tube the mass is stirred with the thermometer, three times from right to left and then three times in the contrary direction, and then continuously and rapidly with a circular motion, avoiding contact with the sides and care being taken to incorporate the solidified fatty acids as they separate, until the whole mass is uniformly turbid. The mercury is then watched until it rises sharply, when the maximum temperature is carefully noted. Duplicate determinations should not differ by more than 0.1°C. It is essential that the fatty acids should be perfectly dry if satisfactory results are to be obtained. The test is chiefly used in evaluating tallows, and other fats intended for soap-making.

For assessing the properties of fats intended for use in chocolate confectionery the method given above for the determination of the solidifying point has been extended to give additional information, notably by M. Pichard (Ann. Falsif. 1923, 16, 197) and by H. R. Jensen<sup>80</sup> (p. 172). In the standard test devised by Jensen are noted the "standard time," from the typical working temperature of 31°C. to the solidifying point, the "crystallisation time," from the minimum to the solidifying point, the "supercooling limit," the temperature at which crystals first become apparent, and the "supercooling index," the difference between the solidifying point and the supercooling limit. For details of the practical use of these figures the original work of Jensen should be consulted.

#### SPECIFIC GRAVITY AND DETERMINATION OF THE WEIGHT OF OIL IN BULK.

The specific gravity and density of each type of oil or fat lie within a narrow range if determined at a given temperature, and these figures are therefore of diagnostic value in the consideration of the quality or purity of the material. Precise determinations of specific gravity and of apparent density are also used in assessing the weight of oil in bulk shipments or stored in large tanks by calculation from the measured volume of the oil.

The determination is made in all cases by means of the ordinary specific-gravity bottle with capillary bored stopper. In general a 25-g. bottle is used, and its capacity in millilitres at 15.5°C. should be determined with the greatest possible accuracy. For oils that are completely liquid at the temperature of determination the bottle is filled with oil at a temperature slightly below the standard temperature (15.5°C.), its stopper is inserted, and the filled bottle is immersed in a water bath kept at the standard temperature until all expansion has ceased. Excess of oil is removed from the stopper, the bottle is removed from the bath and carefully cleaned and dried, and it is then weighed with the usual precautions. The specific gravity of the oil at 15.5°C. is then obtained by dividing the weight of oil observed by the weight of water held by the bottle under the same conditions. The density of the oil is obtained by dividing the weight of oil by the volume of the bottle in millilitres at 15°C. Details of the calculations necessary for the standardisation of specific gravity bottles are given by E. R. Bolton<sup>3</sup> (p. 32) and in British Standard No. 733, 1937.

In many cases a so-called liquid oil will contain a deposit of solid stearine at the temperature at which a specific gravity determination is to be made, and the same oil, after melting and mixing at a higher temperature, can be brought back to the temperature of determination still in a completely liquid state, remaining completely liquid at this temperature for a considerable time.

Solid stearine is much denser than the same stearine dissolved and in a melted condition at the same temperature; it therefore follows that the specific gravity and density of an oil which can deposit stearine will vary with the amount of stearine that has been deposited at the time when the determination is made. The following figures are given by E. B. Bolton and K. A. Williams (Analyst, 1925, 60, 158) to illustrate this: Specific gravity of a palm oil at 32.5°C./15.5°C.; oil liquid, 0.9006; some stearine present, 0.9025; semi-solid, 0.9050; solid, C-9084.

It will thus be seen that in determining specific gravity or apparent density for the purpose of obtaining the weight of a bulk of oil both the temperature at which the volume of the oil is measured and the physical conditions must be known. Then the appropriate conditions can be simulated in the determination and a satisfactory figure arrived at. The factors required for converting to weights of oil are depicted by E. R. Bolton<sup>8</sup> (p. 33), A. Torkawa<sup>66</sup> (p. 47), and in British Standards Nos. 718, 1936; 733, 1937. They depend on the units in which the weights are to be expressed.

In Great Britain, the required weight being in tons, the factor is based on the statutory relation between gallons and pounds, and for practical purposes is the specific gravity, or ratio between the weight in air of a given volume of the oil and the weight in air of the same volume of water, the weight of oil being obtained at the same temperature and that of the water at 15.5°C. In Europe, where the weight is required in kilograms, the factor required is an "apparent"

density—the weight in air of 1 l. of the oil measured at the appropriate temperature. In this case the reference water standard is obviously, the weight *in vacuo* of a standard volume of water measured at 4°C.

Little *vis* is made analytically of the specific gravity of solid fats except in the case of "plasticised" fats, that is to say, fats which have been "creamed" by the incorporation of minute air-bubbles. Here the determination is of value in assessing the increase in volume due to the plasticising process. The most satisfactory and direct method to adopt for all solid fats is that of notation in diluted aqueous alcohol mixtures of known specific gravity, the specific gravity of the sample being taken as equal to that of the spirit in which it just floats at 1 l levels without showing tendency to rise or sink.

A general method for dealing with both solid and fully or partially melted fats is given by SvA. Williams (Analyst, 1946, 4).

#### REFRACTIVE INDEX.

The refractive index of an oil or fat depends on its molecular structure; molecular weight, degree of unsaturation, temperature, and the presence or absence of hydroxy-acids, conjugated bonds and free fatty-acids all contribute to the magnitude of its value. It can be determined with ease and rapidity and affords in many cases a simple and reliable method for the rapid sorting of fats suspected of adulteration.

In the past the refractometer of Amagat and Dubois was much used for the test, but it has been superseded by instruments of the Abbe type, the most commonly used of these being the Dufour-refractometer and the Abbe instrument. In use both instruments are kept at a constant temperature, usually 40°, 25°, or 20°C, by maintaining a constant flow of suitably warmed water through the jackets surrounding the prism, and the refractive-index determination is made on a few drops of the liquid sample placed between the prisms. Corrections may be made to the observed figures if determined at a temperature differing slightly from a standard temperature, to arrive at data for this purpose, by means of the factors, 0.55 per cent per °C. in the case of the butyro-refractometer and 0.5 in each case the correction is added to the observed result if the temperature of observation is higher than the standard temperature, and subtracted if the temperature of observation is lower.

Tables for the conversion of butyro-refractometer readings to true refractive indices are given by Bolton (p. 28) and by R. Kan-

Thompson & Goldsmith (p. 294). The refractive index may be measured by the Abbe instrument with the aid of the instrument with the aid of the instrument. It is of the greatest use in the assessment of the quality of long oils, these giving a value much higher than that of the shorter adulterants.

#### VISCOSITY.

The value of  $\eta$  of an oil is a function of more than its  $P$  as a lubricant for analytical purposes, and for this reason

the test is rarely carried out on oils other than rape and castor oils. The methods used include the common ones of the Redwood, Saybolt, and Engler viscometers, tube viscometers of the Ostwald type, and falling-sphere instruments. The last two types have been standardised in England and are fully described in British Standard No. 188, 1937, revised 1940 (*cf.* LUBRICATION AND LUBRICANTS, Vol. VII, 3854-395a).

#### SMOKE, FLASH, AND FIRE POINTS.

The flash and fire points of fatty oils are determined by means of the Pensky-Marten apparatus in England and the Cleveland apparatus in the U.S.A. Details are given in the Standard Methods for Testing Petroleum and its Products, 6th ed., of the Institute of Petroleum, pp. 116-129, and a report of the American Chemical Society Committee on the analysis of oils and fats (Ind. Eng. Chem. [Anal.], 1940, 12, 379-384). This latter report also deals with the determination of the smoke point (the temperature at which a thin bluish smoke is continuously given off when the oil is heated under specified conditions).

#### MEASUREMENT OF COLOUR.

The depth and shade of colour exhibited by fatty oils has become of great importance in view of the modern demand for refined oils which are bright in appearance and pale in colour, and various requirements are laid down commercially for upper limits in particular cases. In most cases the colour is measured on the Lovibond scale through depths of 1 in., 40 mm., 2 in., or 5-25 in. and is recorded in terms of red and yellow Lovibond units. The method has the advantage that with but little experience a colour can be visualised from its constituent figures, but it is open to the criticism that it is a subjective determination, so that a considerable degree of divergence may be apparent between the results of different workers on the same sample. The photoelectric method put forward by E. B. Bolton and K. A. Williams (Analyst, 1935, 60, 447) is claimed to overcome this; the method gives results in terms of percentages of light of various wave-lengths absorbed by a chosen depth of oil, the usual wave-bands used being the red, green, and blue. Methods are under investigation by a Sub-committee of the British Section of the International Society of Leather Trades Chemists for the conversion of Bolton and Williams data into terms of red, yellow, and neutral units; a preliminary report appears in J. Int. Soc. Leather Trades Chem. 1942, 26, 167.

#### FLUORESCENCE ANALYSIS.

An account of the application of fluorescent methods in the analysis of oils and fats is given by J. A. Radley (Food Manufacture, U944, 19, 23), who indicates that examination of the material under ultra-violet light can in some circumstances give useful information regarding the state of purity or the past history. In general, expressed crude vegetable oils give a yellow fluorescence, though that of soybean

oil is a dark red. On the other hand solvent-extracted oils and oils that have been heated to high temperatures show blue fluorescences. The fluorescence of expressed oils changes to blue on long exposure to air.

T. T. Cocking and S. K. Crews (Quart. Journ. Pharm. 1934, 7, 531) recommend the treatment of olive oils, suspected of being adulterated, with decolourising charcoal, filtering, and examining under the lamp. They claim that genuine oils then appear a faint blue, but if more than 5% of an adulterant is present a strong blue fluorescence is shown.

It should be borne in mind that the results of fluorescence tests are not always conclusive, and attention may be drawn to a note by E. R. Bolton (Analyst, 1930, 55, 746).

## BIBLIOGRAPHY.

- 1 J. Lewkowitsch, revised by G. Warburton, "Chemical Technology and Analysis of Oils, Fats, and Waxes," 6th ed., Macmillan A Co., Ltd., 1923.
- 2 E. B. Bolton and C. Bevis, "Fatty Foods," J. and A. Churchill, 1913.
- 3 E. B. Bolton, "Oils, Fats, and Fatty Foods," J. and A. Churchill, 1928.
- 4 O. D. Elsdon, "Edible Oils and Fats," Ernest Benn, Ltd., 1927.
- 5 T. P. Hilditch, "Industrial Fats and Waxes," 2nd ed., Ballière, Tindall and Cox, 1941.
- 6 T. P. Hilditch, "The Chemical Constitution of Natural Fats," Chapman and Hall, Ltd., 1940.
- 7 P. J. Fryer and F. E. Weston, "Oils, Fats, and Waxes," Cambridge University Press, 1918.
- « G. Martin, "Oils, Fats, and Waxes," Crosby, Lockwood A Son, 1917.
- 9 C. H. Lea, "Rancidity in Edible Fats," H.M. Stationery Office, 1938.
- 10 H. Ingle, "Oils, Resins, and Paints," C. Griffin A Co., Ltd., 1915.
- 11 G. Halphen, "Huiles et Graisses, Vegetales Comestibles," Librairie Polytechnique, C. H. Beranger, 1913.
- 12 "Official and Tentative Methods of the American Oil Chemists' Society," American Oil Chemists' Society, 1946.
- 13 A. Bruno, "Beurres et Graisses Anmales," Librairie Polytechnique, C. Beranger, 1912.
- 14 W. H. Simmons and C. A. Mitchell, "Edible Oils and Fats," Scott, Greenwood A Co., Ltd., 1912.
- is H. N. Brocklesby *et al.*, "Marine Animal Oils," Fisheries Research Board of Canada, 1941.
- 15 J. C. Drummond and T. P. Hilditch, "Relative Values of Cod Liver Oils," H.M. Stationery Office, 1930.
- 17 Institute of Petroleum, "Standard Methods for Testing Petroleum," 6th ed., Institute of Petroleum, 1946.
- » L. E. Andes, "Vegetable Oils and Fats," 4th ed., Scott, Greenwood A Co., Ltd., 1925.
- is» A. GUL, "Oil Analysis," Ilftced- J. B. Lippincott Company, 1927.
- 20 I. F. Laucks, "Commercial Oils," John Toley A Sons, Inc.: Chapman and Hall, Ltd., 1910.
- 21 W. W. Myddleton and T. H. Barry, "Fats, Natural and Synthetic," Ernest Benn, Ltd., 1924.
- 22 C. Ellis, "Hydrogenation of Oils," 2nd ed., D. van Nostrand Co. Inc.: Boutledge A Co., Ltd.
- 23 B. Kanthack, "Tables of Refractive Indices," Adam Hilger, Ltd., 1911.
- 24 L. Ubbelohde and F. Goldschmidt, "Handbuch der Oele und Fette," S. Hirzel, 1908 and 1920.
- 23 C. A. Mitchell *et al.*, "Allen's Commercial Organic Analysis," Vol. 2, J. and A. Churchill, 1924.
- 26 Association of Official Agricultural Chemists, "Official and Tentative Methods," 5th ed., Association of Official Agricultural Chemists, 1940.
- 27 British Pharmacopoeia Commission, "British Pharmacopoeia and Addenda 1-7," Constable A Co., Ltd., 1932 *et seq.*
- 2> J. J. Fox and T. H. Bowles, "Analysis of Pigments, Paints, and Varnishes," Ernest Benn, Ltd., 1927.
- 29 a. S. Jamieson, "Vegetable Oils and Fats," 2nd ed., Chemical Catalog Company Inc., 1942.
- 30 H. B. Jensen, "Chemistry, Flavouring and Manufacture of Chocolate Confectionery and Cocoa," J. and A. Churchill, 1931.
- 31 J. W. Lawrie, "Glycerol and the Glycols," Chemical Catalog Company Inc., 1929.
- 32 A. B. Ling, "Text-Book of Dairy Chemistry," Charman and Hall, Ltd., 1930.
- 33 j. Lund, "Les Relations entre les Constantes des Matières Grasses," Imprimerie J. Duculot, 1927c
- 34 B. S. Morrell and H. B. Wood, "Chemistry of Drying Oik," Ernest Benn, Ltd., 1920.
- 33 w. 3. Simmons, "Soap," Sir Isaac Pitman A Sons, Ltd., 1937.
- 36 G. H. Hunt, "Soap," Scott, Greenwood & Co., Ltd. 1922.
- 37 J. E. Southcombe, "Chemistry of the Oil industries," 2nd ed., Constable A Co., Ltd., 1927.
- 38 j. E. Leach, "Food Inspection and Analysis," Jdnn Wiley A Sons, Inc., 1920.
- 3» A. L. and K. B. Winton, "Structure and Composition of Foods," Vol. 1, John Wiley A Sons, Inc.
- «° I. V. S. Stanilaus and P. B. Meerbott, "American Soap Makers Guide."
- 41 L. Archbutt and B. M. Deeley, "Lubrication and Lubricants," 6th ed., C. Griffin A Co., Ltd., 1927.
- 42 H. E. Cox, "Chemical Analysis of Foods," 2nd ed., J. and A. Churchill, 1938.
- 43 E. A. Evans, "Lubricating and Allied Oils," Chapman and Hall, Ltd., 1933.
- 44 "British Pharmaceutical Codex and addwda," The Pharmaceutical Press, 1934..
- 43 H. J. Johns, "Fertilizer and Feeding Stuff Acts," Butterworth A £o. (Publisher), Ltd., 1928.
- 46 J. F. Liverseege, "Adulteration and Analysis of Food and D?;gB," J. and A. Churchill, 1930.
- 47 C. A. Feitchell *et al.*, "Recent Advance's in Analytical Chemistry, Organic," J. and A. Churchill, 1930.
- 48 J. B. Nicholls, "Aids to the Analysis of Food and Drugs," 6th ed., Ballière, Tindall and Cox, 194°
- 4» A. I. Horvath, "The Soya Bean Industry," E. and F. N' Spon, Ltd., 1938.
- 50, K. S. Markley and W. H. Goss, "Soya Bean Chemistry and Technology," Chemical Publishing Co., 1944.
- 51 J. N. Friend, "Chemistry of Linseed Oil," Gurney and Jackson, 1917.
- 52 E. Fickendey and H. N. Blommendahl, "« 01-palme," Deutscher Ausland Verlag, 1929.
- 53 International Society of Leather Trades' Chemists, "Official Methods of Analysis."
- 54 A. Juckenack\* *et al.*, "Handbuch der Lebensmittel-Chemie," ? Springer, 1942.
- 55 A. Torisawa, "Bulk OS," N. V. Nigh and van Dittmar's Uitg-Mij, 1929.
- 56 A. Grun, "Analyse der Fette und Wachse."
- 57 Hefferand Schonfeld, "Chemieand Technologic der Oele und Fette," J.<Gpiinter, 1936.
- 58 J. B. Leathes and H. S. Baper, "Monographs on Biochemistry—The Fats," 2nd fcd., Longmans, Green A Co., 1925.
- » W. Clayton, "Margarine," Longmans, Green A Co., 1920.
- 60 "Drying Oils and Driers," Oil and Colour Trades Journal, 1934.
- 61 H. K. Dean, "The Utilisation of Fats," A. Harvey 1938.
- 62 D. Burton and G. F. Ddbertshaw, "Sulphated Oils and Allied Products," A. Harvey, 1939.
- 63 B. D. Mason, "Fat, Total Solids, and Moisture," A. Harvey, 1939.
- 64 S.C.I. Food Group (Nutrition Panel), "Vitamin-JE," W. Heffer A Sons, Xtd., 1939.
- 65 A. E. Bailey, "Industrial OU and Pat Products," Interscience Publishers Inc., 1945.
- 66 H. G. Kirschenbauer, "Fats and Ofls," Beinhöld Publishing Corporation, 1944.
- 6-v" Bulletins on Empire Oils and Fats," Imperial Institute.
- 68 British Standards: Nos. 242, 391, 627, 628, 629, 630, 631, 632, 650, 651, 652, 653, 654, 355, 656, 684, 769, 783, 836, 839, 868, 909, 910, 911, 925, 997, British Standards, Institution.

K. A. W.

**OITICICA OIL.** A drying oil obtained in 60% yield from the seeds of *IACANTIA rigida* Benth, a large tree<sup>o</sup> occurring in Brazil which takes jnany years to come into full bearing. The oil, p 0-967-0-968, w<sup>40</sup> 1-504, iodine no. 123-145, saponification value 186-190, free fatty acids as oleic 1-3%, unsaponifiable matter 0-5-1.0% (Bull. Imp. Inst. 1923, 21, 641; 1929,

27, 277) consists of mixed triglycerides of 11% saturated acids, 16% oleic and linoleic acids, the remainder being mainly a-licanic acid (4-keto-J. ».ii.i3.octadecatienoio acid 9 (Brown and Farmer, J.C.8. 1935, 1632), together with a small amount of a-elaostearic acid. Oiticica oil comes on the market as a semi-solid fat or, neat treated, as a permanent oil. The oil, which absorbs oxygen readily from the air, is a substitute for or supplement to tung oil in paints and varnishes, but is to some extent unsatisfactory owing to the film having a lower resistance to moisture (Kappelmeier, Verfkroniek, 1935,8,279). Phenolic resins body more rapidly with the oil than with tung oil and are said to be more durable (Gardner, Amer. Paint J., 1935, 20, 48).

Recorded data for vitamin contents include? vitamin-^ in cooked young pods 2,380 International units per 100 g. (L. E. Booher and R. L. Marsh, U.S. Dept. Agric. Tech. Bull. 1941, No. 802), vitamin-^ in fresh fruit, 126 fig. per 100 g. (L. E. Booher and E. R. Hartzler, *ibid.* 1939, No. 707) and vitamin-\*? 14.7 mg. per 100 g. of fresh fruit (R. G. Burrell and V. R. Ebright, J. Chem. Educ. 1940,17,180). Further investigations by M. E. Hollinger and D. Colvin (Food Res. 1946,10, 255) show that small (2-5-3-0 in.) immature pods may contain 42 mg. of vitamin-O per 100 g. fresh weight, the value decreasing progressively with further growth to 16 mg. in mature (10 in.) pods. There is a loss of ascorbic acid during storage of pods (restricted by low temperature) and also during cooking, pressure cooking causing the least loss.

M. L. M. OKRA (Gumbaut or Gumbo). The fruit of *Mucuna* *aacidentua* L. \*{also classified as *Mucuna esculentys* Moenc&.)« The mucilaginous tissue of the pericarp is edible. The pods are usually collected young and tender (about 4 in. long). Individual pods are roundish, 1-1 in. in diameter, and black when mature. The green fruit is used as a Vegetable *Ps.* etc., in which it also serves as a *fning* agent. In America it is commonly used by canning. Typical percentage analyses of fruit and mature pods are:

A. G. Po.

OLD FUSTIC is the wood of the *CKbrophora hactoria* Gaudich, formerly called *Moms tinctoria* Linn., a tree belonging to the family *Urticaceae*, found in North, Central, and South America, Cuba, Jamaica, etc. The best qualities of old fustio come from Cuba.

Two colouring matters, morin and maclurin, have been isolated from the wood, and these are separated by treating a boiling extract of the rasped wood with lead acetate solution, which precipitates morin as its yellow lead compound, the main bulk of the maclurin remaining in solution. The crude morin obtained by decomposing the lead salt is crystallised from dilute alcohol and then contains only a trace of maclurin, from which it can be freed by dissolving in acetic acid and adding a little hydrochloric acid whereby morin only is precipitated as halogen salt (Bablich and Perkin, J.C.S. 1896, 69, 792).

	Water.	Protein.	Fat.	N-free extract.	Fibre.	Ash.
Fresh fruit (whole)	90.2	1.6	0.2	40	3.4	0.6
Fresh fruit (edible)	80.7	4.2	0.4	121	1.2	1.4
fruits	04.4	0.7	0.09	2.9	0.7	1.2

Morin, C<sub>16</sub>H<sub>10</sub>O<sub>7</sub>, pale yellow needles, m.p. 286-288° after sintering at 281°, is readily soluble in boiling alcohol and dissolves in alkaline solutions with a yellow colour. An olive-green coloration is produced with ferric chloride. Cold acetic anhydride converts the monopotassium salt into *tetra-ooetylmorin*, colourless prismatic needles, m.p. 142-145°; this on further acetylation gives an amorphous compound, and a crystalline penta-acetyl derivative has not yet been prepared. On the other hand, *tetrabromomorin*, m.p. 258°, forms a *penfr-acetyl* derivative, m.p. 192-194° (Benedikt and Hazura, Monatsh. 1884, 5, 667; Bablich and Perkin, Z.c), and *tetrabromomorin ethyl ether*; m.p. 155°, affords *teira-acetyl* *Ueirabronumorin ethyl ether*, m.p. 116-120° (Herzig, *ibid.* 1897, 18, 700).

<sup>1</sup> Atwater and Bryant, U.S. Dept. Agric. Off. Exp. Sta. Bull. 1906, No. 22.  
<sup>2</sup> M. Zieg, Chem. Zeit. 1900, 24, 871.  
<sup>3</sup> McFiey and Bigelow, U.S. Dept. Agric. Div. Chem. Bull. 1894, No. 13.

The mineral <sup>2</sup>Mit, <>M>te of the fruit include: K<sub>2</sub>O, 0.042; CaO, 0.010; MgO, 0.016; P<sub>2</sub>O<sub>5</sub>, 0.043; SO<sub>2</sub>, 0.034; SiO<sub>2</sub>, 0.06% of the fresh material. According to Remington and Shiver (J. Assoc. Off. Anal. Chem. W30, 13, 129) the fresh fruit contains: Fe 0.1, Mn 48.3, Cu 6.4 mg. per kg.

The ripened fruit contains approximately 16% of an oil which, as reported by Jamieson and Baughman (J. Amer. Chem. Soc. 1920, 42, 168), has the following characteristics:  $\gamma$  0.9172,  $\alpha$  1.470

When morin tetramethyl ether is hydrolysed with alcoholic potassium hydroxide,  $\beta$ -resorcylic acid and phloroglucinol monomethyl ether are produced. Morin is, therefore, 5:7:2:4'-tetrahydroxyflavonol (I) (Bablich and Perkin, I.c), and this structure was confirmed by synthesis (von Kostanecki, Lampe, and Tambor, Ber. 1906, 89, 626). Phloracetophenone dimethyl ether was condensed with 2:4-dimethoxybenzaldehyde and the resulting chalcone converted into the corresponding flavanone, the winitroso derivative of which yielded morin 7:2:4'-trimethyl ether on hydrolysis, and from this monn

Value 95.0, iodine value 195.2, saponification value 195.2, iodine value 0.23, acetyl value 21, and van 1.4, 67.320. <sup>1801</sup> soluble acids 96.2%, soluble acids 0.14V. <sup>1801</sup> matter 0.37%. The composition of the oil is given as:

Glycerides of arachidic acid	0.06
Glycerides of stearic acid	2.78
Glycerides of palmitic acid	27.23
Glycerides of oleic acid	49.74
Glycerides of linolenic acid	28.68

was obtained by demethylation. Robinson and Venkataraman (J.C.S. 1929, 61) synthesised morin by 2:4-dimethoxybenzoylation of *m*-methoxyphloracetophenone followed by hydrolysis and demethylation of the product.

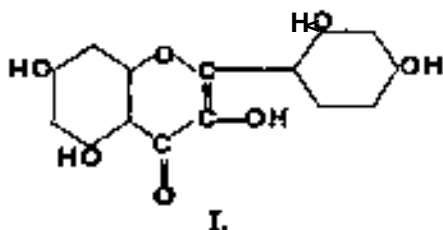

*Morin 3:2'-A'-trimethyl ether*, pale straw-coloured prismatic needles, m.p. 132° (Robinson and Venkataraman, *I.e.*), *morin 2:1:2'A'-tetramethyl ether*, yellow needles, m.p. 131-132° (Babich and Perkin, *I.e.*), and *morin 3:7:2:4\*-tetraethyl ether*, yellow needles, m.p. 126-128° (Perkin and Phipps, *ibid.* 1904, 85, 61) are also described.

*Morin pentamethyl ether*, m.p. 154-157° (Herzig and Hofmann, *Ber.* 1909, 42, 155; Perkin and Watson, *J.O.S.* 1915, 107, 207) is hydrolysed by boiling alcoholic potassium hydroxide into methoxyfisetol dimethyl ether (2-hydroxy-co:4:6-trimethoxyacetophenone) and *ε*-resorcylic acid. *Nitro-* and *amino-morin pentamethyl ether* melt at 223-225° and 204-205°, respectively.

Morin forms oxonium salts with mineral acids (Perkin and Pate, *ibid.* 1895, 67, 649); of these, the sulphuric acid compound, C<sub>15</sub>H<sub>10</sub>O<sub>7</sub>·SO<sub>3</sub>, known as anhydromorin sulphate, is abnormal, and according to Robinson and Venkataraman (*i.c.*) is probably represented by formula (II).

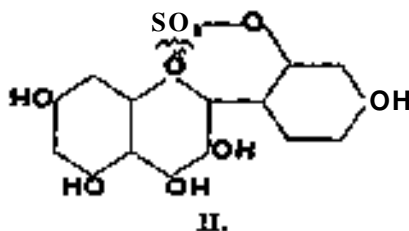

For absorption data of morin, see Grinbaum and Marchlewski (*Biochem. Z.* 1937, 290, 261; *Bull. Acad. Polonaise*, 1937, A, 60).

Morin closely resembles kaempferol (5:7:4'-trihydroxyflavonol) in its dyeing properties. Olive-yellow, yellow, lemon-yellow, and deep olive-brown shades are obtained on wool mordanted with chromium, aluminium, tin, and iron, respectively (Perkin and Wilkinson, *J.C.S.* 1902, 81, 590).

Maclurin.—A description of this substance and its derivatives is given elsewhere (*v.* Vol. VII, 435a).

#### Dyeing Properties of Old Fustic.

The olive-yellow or old-gold colours which fustic yields when used with chromium mordant and the greenish-olives obtained with the use of copper and iron mordants are all fast to light and milling, but the yellow colours yielded in

conjunction with aluminium and tin possess only a moderate degree of fastness with respect to light. Fustic is chiefly employed in wool dyeing with potassium dichromate as the mordant, mainly in conjunction with logwood alizarin, etc., for the production of compound shades, olive, brown, drab, etc., and as a bottom for black.

E. J. C

**OLEFINS.** These substances are hydrocarbons which contain 2, 4, 6, etc., atoms of hydrogen less than the corresponding paraffins, according as they belong (respectively) to the mono-, di-, and poly-olefinic sub-groups.

#### MONO-OLEFINS, C<sub>n</sub>H<sub>2n</sub>.

The mono-olefins or ethylenes all contain 2 atoms of hydrogen less than paraffins of the same number of carbon atoms. The deficiency in hydrogen, which is regarded as rendering the members of the group *unsaturated*, affects a pair of adjacent carbon atoms in each molecule, and is represented in formulae by a double bond between the two atoms, and in chemical nomenclature by the termination *-ene*. All members of the homologous group which contain more than 3 carbon atoms can display three types of isomerism, viz. (1) paraffinic isomerism due to the branching capacity of the carbon chain, (2) double-bond isomerism due to the number of different positions in the chain which the double bond may occupy, and (3) *cis-trans-isomerism* arising from alternative spatial distributions of the atoms or groups attached to the doubly bound carbon atoms. In this way butene, the third member of the mono-olefinic group, can exist in four isomeric forms.

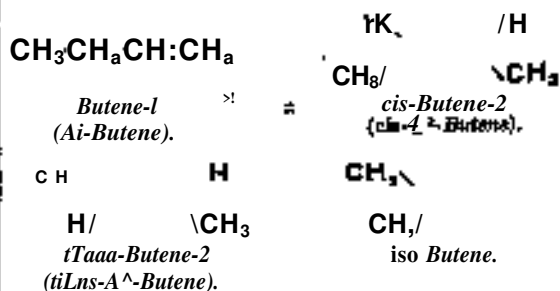

pentene, C<sub>5</sub>H<sub>10</sub>, in six forms (5 structural)\* hexene, C<sub>6</sub>H<sub>12</sub>, in seventeen forms (13 structural), and so on.

**Occurrence.**—The mono-olefins do not occur extensively in natural materials. They are found in thermally decomposed ("cracked") mineral oils, but their isolation as pure individuals from the complex mixtures of hydrocarbons so obtained is usually attended with great difficulty.

#### Methods of Preparation.—

(1) *The Dehydration of Monohydric Alcohols.*—C<sub>n</sub>H<sub>2n+2</sub>O → C<sub>n</sub>H<sub>2n</sub> + H<sub>2</sub>O. This process of very wide applicability is carried out by heating the alcohols at suitable temperatures with dehydrating agents such as sulphuric acid, phosphoric acid; phosphoric oxide, phthalic anhydride, anhydrous oxalic acid, etc.; or by slow distillation of the alcohols with small amounts of catalysts such as hydrogen bromide, iodine; and aniline hydrobromide; or by the passage of their vapour

over contact reagents such as alumina, thoria, silica gel or kaolin, heated to the requisite high temperatures. The structure of the alcohol has an important influence on ease of dehydration: tertiary alcohols dehydrate more readily than secondary, and these again more readily than primary; secondary alcohols,  $\text{CHRR}'\text{-OH}$ , and tertiary alcohols,  $\text{CRR}'\text{-OH}$ , usually tend to dehydrate in all possible directions to give mixtures of olefins:

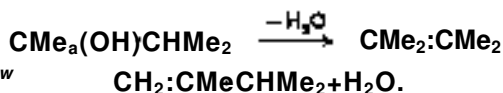

Thus the preparation of tetramethylethylene and *cis*-methylpropylethylene from dimethylpropyl carbinol according to the above equation is effected by heating the carbinol (408 g.) with anhydrous oxalic acid (1,200 g.) in a oil-bath under reflux\* for 8 hours, and then distilling off the hydrocarbon formed. The distillate is washed with water, dried over calcium chloride, and then repeatedly distilled over sodium. Careful fractionation through a good 46-cm. column at a reflux ratio of 10:1 gives tetramethylethylene and *cis*-methylpropylethylene of b.p. 72-9-73-2°/760 mm. and 23-56-0°/760 mm., respectively (Schurman and Boord, J. Amer. Chem. Soc. 1933, 55, 41&6).

Alcohols which undergo rearrangement of the carbon skeleton under ordinary dehydration conditions, and especially those containing sensitive secondary or tertiary alkyl groups, can often be dehydrated by heating the easily decomposable esters which they form with xanthic acids (Tschugaeff, Ber. 1899, 3332; Whitmore and Simpson, J. Amer. Chem. Soc. 1933, 55, 3809).

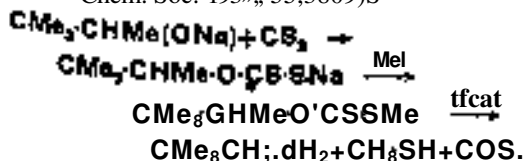

(2) The Elimination of Hydrogen Halide from Monohalogen Derivatives of Paraffins.—This operation is carried out by heating the organic halide with alcoholic potassium or sodium hydroxide, with quinoline or with other inorganic organic base:

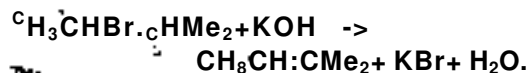

Elimination can often be induced by passing the vapour of the halide over heated materials such as barium chloride or finely divided metals (e.g. Fe, C, Ni) heated to red heat. Oxidic materials such as lime and lead oxide, ferric and stannic oxides, and especially the ferric oxide, react with great readiness.

(3) The Dehalogenation of 1:2-Dihalogeno-paraffins.—The decomposition of organic dihalides in which the halogen atoms are attached to adjacent carbon atoms is carried out by (a) treatment with zinc dust:

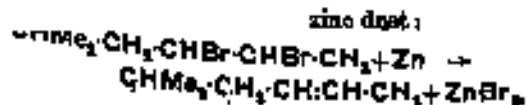

(6) treatment of their solutions in alcohol by zinc-copper couple (Gladstone and Tribe, J.C.S. 1878, 21, 306), or (c) spontaneous decomposition of the di-iodides which are formed by the action of phosphorus tri-iodide on the corresponding 1:2-diols (Kuhn and Winterstein, Helv. Chim. Acta, 1928, 9, 87).

Thus, *cis*- and *trans*-A<sup>4</sup>-octenes are (respectively) conveniently obtained from the corresponding *dl*- and *meso*-4:5-dibromo-octanes (Young *et al.* J. Amer. Chem. Soc. 1937, 59, 403). Either of these dibromides is added gradually to excess of freshly prepared zinc-copper couple covered with 90% alcohol. The alcohol is gently boiled during the addition, and afterwards heating is increased until the olefin mixed with alcohol distils. On dilution of the olefin-alcohol mixture with water the hydrocarbon separates and is dried over calcium chloride and rectified. The *cis*-octene boils at 120-120-5°/760 mm. and the *trans*-octene at the same temperature.

(4) The Action of Grignard Reagents or Zinc Alkyls on Alkyl Bromides.—

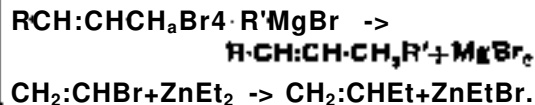

(5) The Action of Zinc on 2'Bromo-ethers.—This method is especially valuable for the synthesis of isomeric hexenes, heptanes, etc. (Boord *et al.* *ibid.* 1930, 52, 3396; 1931, 58, 1505):

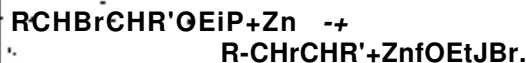

The required bromo-ethers can be synthesised in the stages:

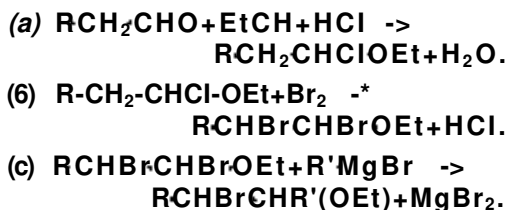

(6) The Distillation of Quaternary Ammonium Hydroxides or of Alkyl Ammonium Phosphates.—

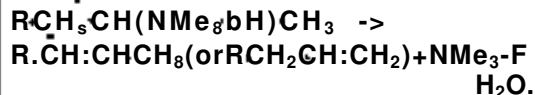

(7) The Action of Metals on Mixtures of Alkyl Halides and Halogeno-olefins (Wuriz Reaction).—

Sodium, copper, reduced silver, and sometimes magnesium react with the bromo- or iodo-derivatives in ethereal solution:

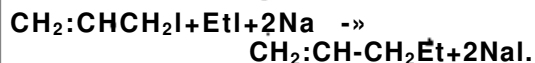

(8) The Polymerisation of Simple Olefins (*v. supra*).

(9) The Thermal Decomposition ("Cracking") of Paraffins or Higher Olefins.—Large quantities of ethylene, isobutene, butadiene, etc., are obtained in commercial cracking processes. A

few molecules probably first decompose to give free alkyl radicals ( $C_nH_{2n+2} \rightarrow R^* + R'^*$ ), and the latter initiate degradative chain reactions by removing hydrogen atoms from neighbouring

molecules. Thus, for octane, hydrogen may be displaced from any one of the eight carbon atoms, yielding a radical,  $C_8H_{17}^*$ , which will further decompose, *e.g.*,

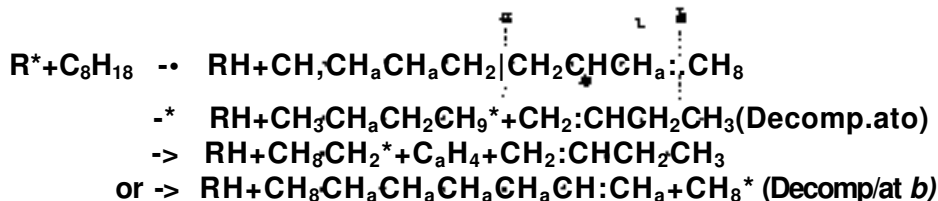

(*cf.* Rice, *ibid.* 1931, 53, 1959; 1932, 54, 3529; 1933, 55, 3035; *Ind. Eng. Chem.* 1934, 26, 259; 1938, 30, 955).

**Physical Properties.**—The early members of the homologous series are gases at ordinary temperatures, *ra*-pentene (b.p.  $30^{\circ}2'$ ), its isomers (b.p.  $<38^{\circ}5'$ ) and numerous succeeding members are liquids, and the highest members of the series are solids. In general,  $J^1$ -olefins boil lower than  $J^2$ -olefins, and those *iso*-olefins in which branching of the chain occurs at one of the ethylenic carbon atoms tend to boil lower than the corresponding *normal* compounds; accumulation of alkyl groups, however, at the ethylenic centres, usually raises the boiling-point.

**Oxidation.**—Olefins are oxidised by dilute permanganate to yield 1:2-glycols; on further oxidation the carbon chain is severed:

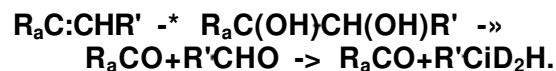

Chromic acid and certain other oxidising agents behave somewhat analogously. Peracetic acid and perbenzoic acid yield olefin epoxides

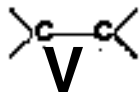

but in the case of the former reagent the epoxide becomes largely converted into the mono-acetate of the 1:2-diol. Hydrogen peroxide, in presence of a trace of osmium tetroxide, yields with olefins the corresponding 1:2-glycols; lead tetra-acetate in acetic acid similarly yields 1:2-glycols, or the corresponding diacetates; silver benzoate and iodine form a complex which converts olefins into their 1:2-glycol dibenzoates.

**Structural Lability and Isomerisation.**—The carbon chains of alcohols and other precursors of olefins often undergo rearrangement during elimination reactions. Thus mixtures of  $J^2$ -butene and *iso*butene are obtained by the dehydration, of *iso*butyl alcohol with zinc chloride or heated contact catalysts (Whitmore, *J. Amer. Chem. Soc.* 1932, 54, 3278), and mixtures of *isobutene* and  $J^1$ -butene by the dehydration of *n*-butyl alcohol over heated aluminium phosphate. Tertiary alcohols or halides are particularly subject to skeletal rearrangement during conversion into olefins:

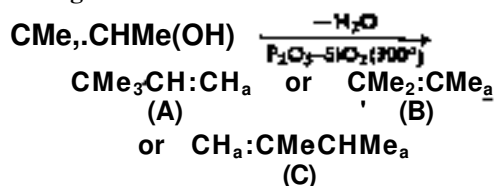

but the rearrangement is not in general a characteristic merely of the elimination processes, but can occur with the olefins themselves around  $300^{\circ}$  in the presence of suitable contact reagents. Thus each of the above *iso*hexenes tends to reach the equilibrium  $A \rightleftharpoons B \rightleftharpoons C$  in presence

*ca.* *ca.* *ca.*  
*i.* JB1%, 31%.  
of phosphoric acid-silica gel at  $300^{\circ}$ . According to Whitmore (*ibid.* pp. 3274, 4011; *J*933, 55, 812, 1119; 1934, 56, 1395) the mechanism of the structural change can be represented in the following way. The system (a), in which X is a potential anion (Cl, OH, OMe, etc.), passes first by loss of X into a cation (6),

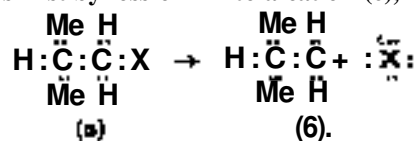

and then by loss of a proton into an olefin. In the latter stage, however, the system (6) can apparently:

- (1) lose a proton directly

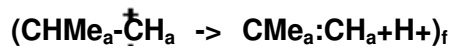

- (2) transpose by shift of a H atom with its bonding pair of electrons from one carbon atom to another, before losing a proton ( $CHMe_2\dot{C}H_2 \rightarrow \dot{C}Me_2CH_2 \rightarrow CMe_2:CH_2 + H^+$ ), or

- (3) transpose by shift of an alkyl group with its bonding pair of electrons from one carbon atom to another before losing a proton

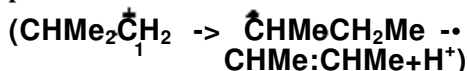

(*see* Whitmore, *l.c.*)

The olefins themselves, under the influence of suitable catalysts, undergo both structural and *cis*-*trans*-isomerisation. Strong acids promote double-bond migration by causing addition of hydron at the more negative of the ethylenic carbon atoms, followed by loss of hydron from another carbon atom:

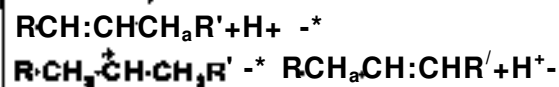

Electron-deficient compounds of the inorganic group which provides effective catalysts for the



**Friedel-Crafts** reaction (AlCl<sub>3</sub>, BF<sub>3</sub>, etc.) promote cis-trans isomerisation in olefins. The reaction is doubtless of the character:

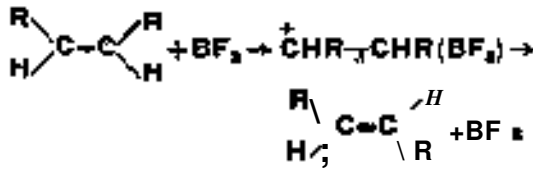

(c. Price and Meister, *ibid.* 1939, 61, 1595). Contact catalysts such as alumina and thoria can promote both double-bond migration and skeletal rearrangement of olefins (or of their alcohol precursors) at temperatures around 400°. According to Goldwasser and Taylor (*ibid.* pp. 1751, 1762); the combined reaction may involve a cyclic intermediate:



**Polymerisation.**—This is brought about by the action of light, heat, or chemical catalysts, but some aryl olefins such as styrene polymerise spontaneously at room temperatures unless special precautions are taken to exclude polymerising agents or agencies, or unless a chemical inhibitor such as sulphur is added. Polymerisation may be high-molecular or low-molecular, the former resulting in products of high molecular weight (say,  $M=1,000-400,000$ ), and the latter normally yielding mixtures of only the lower polymeric stages (dimer, trimer, etc.).

The high-molecular products usually consist of a series of saturated linear polymer-homopolymers, formed by the linking of different number of monomer molecules head to tail:



Individual molecule\* in these series differ from one another only in chain-length, i.e., in the value of  $n$ . The average value which  $n$  assumes in any polymerisation depends jointly on the conditions of the olefin and the conditions of polymerisation. Ethylene yields polyethylene, a tough horn-like translucent solid having a melting point of 30000-50000, when it is polymerised at 100-300° at 1,200 atm., or greater pressure (B.P.).

It yields with enormous speed and evolution of heat a somewhat elastic solid of  $M=30,000-400,000$  when it is brought into contact with catalytic agents such as boron trifluoride, titanium tetrachloride, or aluminium chloride at temperatures between -10° and 80° (see Parke, and Frolich, *ibid.* 1940).

The formation of a few activated monomer molecules, or of a few radical molecules of high energy content (the active centre denoted by \*), which combine successively monomer molecules to produce in turn activated dimer, trimer, tetramer, etc. molecules, until finally activity is lost by combination of active centres with other active centres in the walls of the containing vessel.

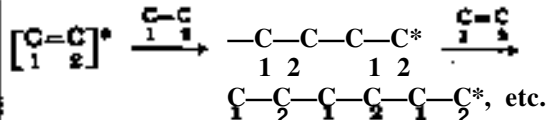

Activation of the monomer molecules by chemical reagents appears to arise (a) by the action of organic radicals (e.g., derived from peroxides), or paramagnetic molecules (e.g., oxygen):

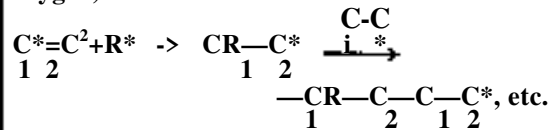

and (b) by polar mechanism involving either complex formation between the reagent and olefin or by attachment to the more hydrogenated ethylenic carbon atom of hydron derived from an acid HX contained in, or generated in traces from, the catalyst:

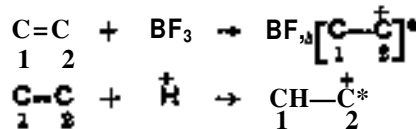

Activation of olefin molecules by light or by heat results either from direct energisation to form (presumably radical) molecules of high energy content, or from the production of free radicals by photo- or thermal decomposition of some of the olefin or extraneous molecules present. It is noteworthy, however, that high temperature (non-catalytic) treatment of olefins commonly gives rise to low-molecular "polymers" in the formation of which chain-scission frequently occurs with formation of odd- as well as even-membered chains.

The low-molecular products tend to be produced preferentially at more or less elevated temperatures by the action of strong acidic catalysts, especially sulphuric and phosphoric acids, or of halides such as boron trifluoride, aluminium chloride, titanium tetrachloride, and antimony chloride. The polymers so formed are usually branch-chained olefins formed by the mechanisms:

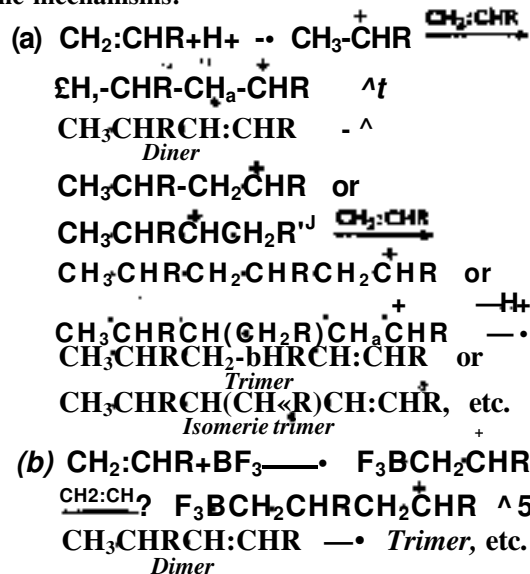

and are subject during formation to the skeletal rearrangements discussed above. At pressures above the atmospheric pressure, however, polymerisation by aluminium chloride may be complicated by the formation of paraffins and cyclic olefins (Ipatieff and Grosse, *ibid.* 1936, 58, 915). During the thermal decomposition of paraffins and olefins polymerisation occurs side by side with degradation, so that normal-chain hydrocarbons tend to pass in part into branched-chain forms.

**Aromatisation.**—Normal and branched-chain olefins containing 6 or more carbon atoms can be converted into aromatic hydrocarbons, with loss of hydrogen, by heating them at temperatures above 400° in contact with certain catalysts such as chromic oxide gel (*cf.* Goldwasser and Taylor, *ibid.* 1939, 61, 1766). Thus 2-methylpent-2-ene,  $\text{CMe}_2\text{:CHCH}_2\text{CH}_3$ , 2-ethylbutene-1,  $\text{CH}_2\text{:CEtCH}_2\text{CH}_3$ , 3-methylpentene-2,  $\text{CH}_3\text{CH:CMeCH}_2\text{CH}_3$ , all undergo 20-27% conversion to benzene at 424° in presence of chromic oxide gel. For mechanism of cyclisation and dehydrogenation, see Bideál, *Ghem. and Ind.* 1943, 62, 335.

**Additive Reactions.**—Olefins display a strong tendency to add reagents at their unsaturated centres. The number of reagents which can so be added is very large, and the ease of addition varies enormously. In many instances reaction proceeds spontaneously, in others chemical catalysts are required to promote reaction, and in still others light, high temperatures or high pressures are needed. The following are among the principal types of addenda and additive reactions which can be employed.

**Halogens.**—The halogens ( $\text{Cl}_2$ ,  $\text{Br}_2$ ,  $\text{I}_2$ ,  $\text{AlI Br}$ ) usually combine to give dihalides,



but under certain conditions substitution occurs (*see* Substitute Reactions, below). The completeness of reaction and the speed of addition render certain of the halogens ( $\text{ICl}$ ,  $\text{IBr}$ , and  $\text{Br}_2$ ) suitable for quantitative determination of the unsaturation of unconjugated oils, fatty acids, polyene hydrocarbons, etc.

**Halogen Acids.**—Hydrogen bromide, hydrogen iodide, and (often) hydrogen chloride add to olefins to give alkyl halides,



Normally, a polar mechanism is pursued; hence addition to an olefin  $\text{R-CH:CHR}'$  in which R and R' are groups of equal or nearly equal electronegativity occurs in both possible directions, presumably owing to the nearly identical activation energies of the two reactions. In unsymmetrically substituted olefins, however, one direction of addition is favoured at the expense of the other, and in those examples where the degree of substitution at the two ethylenic carbon atoms differs, the addition proceeds predominantly (probably uniquely) in accordance with the Markownikow rule, *i.e.*, the halogen atom of the addendum attaches itself to the ethylenic carbon atom bearing the smaller

number of hydrogen atoms, so giving secondary or tertiary halides:



When, however, hydrogen bromide is the addendum, addition may be of *abnormal* character (*i.e.*, it may occur in the direction opposite to that required by the Markownikow rule) if the olefin is contaminated with traces of peroxide or (sometimes) if molecular oxygen is present (*cf.* Smith, *Ghem. Soc. Annual Rep.* 1939, 36, 225). It is thought that the oxygen or peroxide liberates from the halogen acid atomic bromine which attacks preferentially one (the more hydrogenated) of the ethylenic carbon atoms:

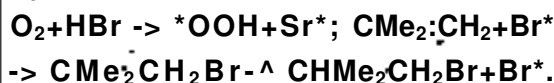

etc. The abnormal type of reaction probably applies rigidly to all olefinic additions occurring, by radical mechanisms, *i.e.*, additions initiated by ultra-violet light, peroxides, and free radicals. *Cis-* and *trans-forms* of olefins react alike with halogen acids.

Hypochlorous and hypobromous acids add at the double bonds of olefins to give chlorohydrins or bromohydrins. In general the hydroxyl group tends to attach itself to the least hydrogenated or more positive ethylenic carbon atom, but in many cases addition occurs in both directions, giving mixtures of isomeric halohydrins:



Esters of hypohalous acids or equivalent solutions of halogens in alcohols frequently act similarly.

**Hydrogen Sulphide.**—As in the case of halogen acid additions, both normal and abnormal reactions can be promoted. Addition of the liquid reagent occurs with moderate ease to simple olefins in U.V. light (*ca.* 2,800 Å.) to give mercaptans, sulphides, and disulphides:



The direction of addition is *abnormal* (Vaughan and Rust, *J. Org. Chem.* 1942, 7, 472). The presence of sensitizers such as acetone usually expedites reaction. Addition in the normal direction can be effected, but with greater difficulty, when liquid hydrogen sulphide reacts with the olefin in presence of such catalysts as nickel on kieselguhr (200-300°), ferrous sulphide (100° or above), ferric oxides (100° or above), or sulphur. *Cf.* Böeseken and Van Lunde, *Rec. trav. chim.* 1935, 54, 739; Farmer and Shipley, also Naor, *J. Polymer Science*, 1946, 1, No. 7.

**Mercaptans.**—Aryl mercaptans (thiophenols) add to olefins in the *abnormal* direction (Ipatieff, *J. Amer. Ghem. Soc.* 1938, 60, 2731):

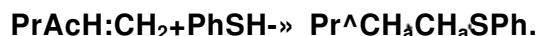

Normal addition, however, occurs if the olefin is first freed from traces of peroxide (Jones and Reid, *ibid.*, p. 2452). In general, ultra-violet

light and traces of peroxide promote abnormal addition, and sulphur, ferrous sulphide, etc., normal addition (*cf.* Farmer and Shipley\* also Naylor, *i.e.*). Aliphatic mercaptans add less readily than do thiophenols, but more readily than does hydrogen sulphide.

**Sulphur Dioxide.**—In presence of traces of peroxide, U.V. light, lithium nitrate, and certain others catalysts, sulphur dioxide adds readily to olefins, giving polymolecular sulphones:

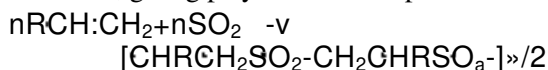

(Marvel *et al.*, *ibid.* 1937, 59, 707). Analogous products are formed from unconjugated polyolefins such as rubber (Farmer and Morrison-Jones, unpublished work).

**Sulphur.**—Most olefins containing the grouping  $\text{CH}_2\text{CKI:CH}$  react with sulphur at temperatures above 100°. The primary products appear to be mono-, di-, tri-, etc., sulphides  $\text{RSR}$ ,  $\text{RS-SR}$ ,  $\text{R-S-S-R}$ , etc. (where R is the original olefin molecule modified by gain or loss of one hydrogen atom) of undetermined constitution, but on prolonged or undue heating hydrogen sulphide and mercaptans are formed by decomposition (*see* Farmer and Shipley also Naylor, *i.e.*). The molecule-linking reactivity of sulphur is doubtless responsible for the vulcanisation of rubber.

**Sulphuric Acid.**—Olefins combine with strong sulphuric acid to give alkyl hydrogen sulphates. These acidic esters become hydrolysed more or less easily when boiled with water, so forming secondary alcohols:

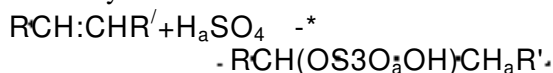

**Water.**—The hydration of olefins cannot be accomplished by the direct action of water, but is readily promoted by acids and acidic reagents:

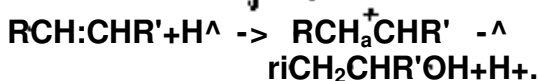

In industrial processes sulphuric acid is extensively used, but since this reagent can effect, reversibly, (a) hydration, (b) esterification, and (c) polymerisation of the olefin, all of which reactions may occur side by side, it is necessary to control carefully the strength and quantity of the acid employed, and the temperature. The precise course which reaction takes with sulphuric acid of given strength depends largely on the constitution of the olefin. Thus propene and 4-pentene form esters with 85-92% sulphuric acid, whereas 2-pentene gives a mixture of 2- and 3-pentanol; other olefins, however, undergo polymerisation with 80% and esterification with 70% acid. The sulphuric acid esters formed can often be easily hydrolysed to give the corresponding alcohols.

Aqueous organic acids, diluted nitric, phosphoric, sulphonic, and picric acids have been used as hydrating agents, the reaction proceeding less readily with the weaker acids, but still often occurring at measurable rates even with 0.1 M. solutions of dibasic organic acids.

**Organic Acids and Phenols.**—Olefins combine with organic acids such as mono-, di-, and tri-

chloroacetic acids, and o-, m-, and p-hydroxy benzoic acids in presence of boron trifluoride to give esters; with phenols, ethers are formed,

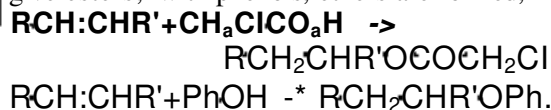

**Paraffins.**—Paraffins combine with olefins in presence of sulphuric acid (Birch, Dunstan, *et al.*, J. Inst. Petroleum Tech. 1938, 24, 308; Birch and Dunstan, Trans. Faraday Soc. 1939, 35, 1013), aluminium chloride, or a catalyst composed of boron trifluoride, finely divided nickel, and a little water (Ipatieff and Grosse, J. Amer. Chem. Soc. 1935, 57, 1616; 1936, 58, 913) to give woparaffins:

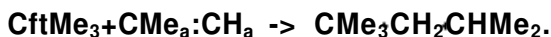

Cycloparaffins can sometimes be added to olefins in presence of sulphuric acid, and somewhat similar additions of paraffins to olefins can be effected by heat and pressure alone, and by the use of activated halide catalysts.

**Aromatic Hydrocarbons.**—Benzene, toluene, naphthalene, etc., combine with olefins in presence of boron trifluoride, aluminium chloride, sulphuric acid, and ferric chloride, the olefins thus serving as alkylating agents (Nieuwland *et al.*, J. Amer. Chem. Soc. 1936, 58, 1007; Ipatieff *et al.*, *ibid.*, pp. 919, 2339; 1938, 60, 353; J. Org. Chem. 1940, 5, 253; Potts and Carpenter, J. Amer. Chem. Soc. 1939, 61, 663). In this way propene condenses with benzene in presence of boron trifluoride to give mono-, di-, tri-, and tetra-propyl derivatives of benzene (Nieuwland, J. Amer. Chem. Soc. 1935, 57, 1547).

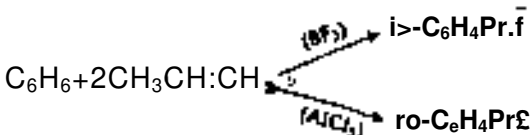

**Phenol-formaldehyde Resins.**—Olefins combine with phenol-formaldehyde resins when heated with the latter at about 180° (Cunneen, Farmer, and Koch, J.G.S. 1943, 472):

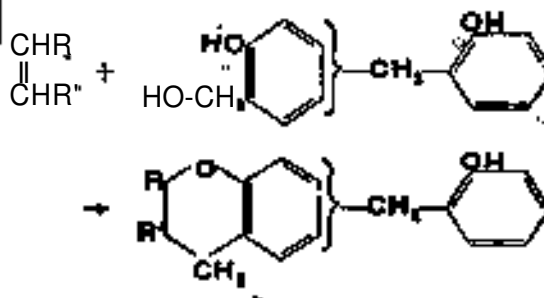

**Diphenylketen.**—Olefins combine with diphenylketen, but not with keten, when heated with the reagent at 70-100° (Staudinger and Suter, Ber. 1920, 53 [B], 1045; Farmer and Farooq, J.G.S. 1938, 1925):



*Ozone.*—Ozone addition products, called ozonides, are formed apparently quantitatively by passing a stream of ozonised oxygen (or air) through cooled solutions of the olefins:

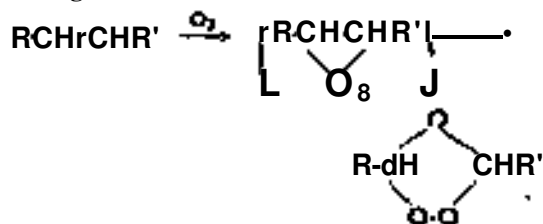

The exact constitution of the ozonides (which unless carefully prepared, and sometimes unavoidably, are partly or wholly polymeric derivatives) is uncertain, but the isolable monomeric forms appear most often to be of ether-peroxide type, as shown in the equation. These relatively stable forms may well, however, be preceded by less stable primary forms, the molozonides of Staudinger (Ber. 1925, 68 [B], 1088).

The ozonides as a class are easily decomposed, and in many cases decompose spontaneously with great violence when isolated from solution; their solutions, however, are relatively stable. The regulated decomposition of the ozonides of olefinic substances affords the most valuable diagnostic evidence concerning the olefinic constitution, and especially of the double bond position. It is usual to bubble approximately the theoretically required amount of ozone (as ozonised oxygen) through a solution of the olefinic substance in an inert solvent at about 0° (over-ozonisation is to be avoided), then to remove the solvent at reduced pressure, and finally to decompose the ozonide (1) by warming or vigorously stirring it with a large excess of water, (2) by reducing it, either catalytically with hydrogen in presence of finely-divided platinum or by zinc and acetic acid, (3) by heating it with powdered Raney nickel in an inert solvent (Cook and Whitmore, J. Amer. Chem. Soc. 1941, 63, 3540), or (4) by stirring it with an alkaline suspension of silver oxide at 90-95°. The products are aldehydes, ketones or mixtures of these,



but usually the aldehydes are partly converted (Wholly by method 4) into the corresponding carboxylic acids.

For the quantitative oxidative cleavage of the ozonides of olefins of high mol.-wt., see Asinger (Ber. 1942, 75 [B], 656); for the estimation of the unsaturation of olefinic polymers of high mol.-wt., see Cheyney and Kelley (Ind. Eng. Chem. 1942, 34, 1323). For review of ozonisation technique, see Lone, Chem. Rev. 1940, 27, 437.

*Thiocyanogen.*—This reagent (usually generated *in situ* from sodium or plumbous thiocyanate) adds to the double bonds of olefins to give di-thiocyanates:

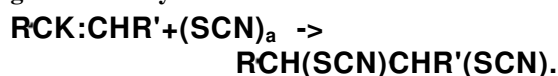

The dithiocyanates of various of the simpler olefins are crystalline compounds, suitable for characterisation of the latter (Dermer and Dysinger, J. Amer. Chem. Soc. 1939, 61, 750). The additive reaction has been applied by Kaufmann (Arch. Pharm. 1925, 263, 675) to the quantitative estimation of the unsaturation of olefinic substances, especially to that of the drying oils (see this Vol., p. 616).

*Nitrogen Compounds.*—Nitric oxide reacts with olefins, liberating nitrogen and forming *inter alia* isomeric nitro-olefins,  $\text{C}_n\text{H}_{2n-1}\text{NO}$ , and nitrosonitrosites,  $\text{RCH}(\text{NO})\text{CH}(\text{NO})\text{R}'$  (Bloomfield, J.C.S. 1944, 120). Nitrogen trioxide and tetroxide react additively, forming nitrosonitrosites and dinitro-compounds.

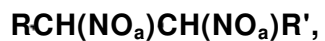

respectively. Nitrosyl chloride yields nitrosyl chlorides,  $\text{RCH}(\text{NO})\text{CHClR}'$ , which are frequently crystalline, and therefore suitable for the characterisation of the parent olefins.

*Aromatic Bases.*—Aromatic bases, and especially aniline and toluidine, unite with olefins when heated with the latter in presence of a hydrohalic acid of the base. Two types of addition occur:

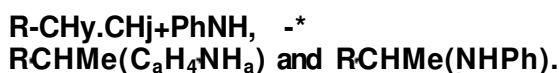

*Hydrogen Sulphite.*—Oxygen and peroxides catalyse the addition of sodium bisulphite to olefins (Kharasch *et al.*, J. Org. Chem. 1938, 3, 175):



*Alkali Metals.*—(Mono-, di-, triaryl-, and tetraaryl-)olefins add alkali metals, giving mono-molecular or poly-molecular metallic derivatives (Schlenk, Annalen, W28, 63, 1; 1930, 479, 58, 78):

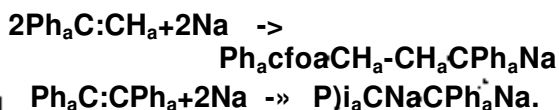

*Metal flocculation.*—Olefins form complexes with numerous metallic salts, *e.g.* with  $\text{CuCl}_2$ ,  $\text{ZnCl}_2$ ,  $\text{FeCl}_3$ ,  $\text{AlCl}_3$ ,  $\text{PtCl}_4$ , and  $\text{K}_2\text{PtCl}_6$ . The lower olefins are absorbed by solid cuprous chlorite, so forming easily dissociated compounds (see Gilliland *et al.*, J. Amer. Chem. Soc. 1936, 61, 1960).

*Substitutive Reactions.*—Under non-polymerising conditions of reaction many reagents combine with olefins substitutively at the carbon atoms adjacent to the double bond. Such reactions appear usually to involve chain mechanisms, and are probably initiated at the double bond. Illustrative of these  $\alpha$ -methylene substitutions are the following:

*Halogenation.*—Olefins of the type



are substituted by chlorine and by bromine at low or moderate temperatures and at (about) atmospheric pressure (Groll, Hearne, *et al.*, Ind. Eng. Chem. 1939, 31, 1239, 1413, 1530).

Reaction occurs in the absence of light and without other catalyst than the walls of the vessel. Thus isobutylene yields with chlorine  $\text{CH}_2\text{ClCHMe:CH}_2$  (87%),  $\text{CMe}_2\text{:CHCl}$ , (3%),  $\text{CMe}_2\text{Cl}$ . (1%),  $\text{CMe}_2\text{CICH}_2\text{Cl}$  (6%), and saturated dichlorides and trichlorides (3%). Normal olefins, and ethylene, require higher temperatures of reaction than branched-chain ethylenes.

*Maleic Anhydride.*—Olefins combine with maleic anhydride, and with maleic esters to give (mainly) olefin-succinic anhydrides or succinates when heated with the latter at temperatures above 200° (Farmer, Trans. Faraday Soc. 1942, 38, 340):

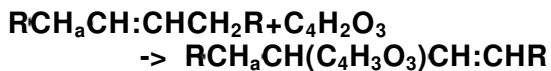

A somewhat similar reaction occurs when olefins are heated with maleic anhydride in solvents (benzene, toluene, etc.) containing a little diphenzoyl peroxide (Farmer and Farmer, unpublished work), or sometimes (Wagner-Jaia-egg, Ber. 1930, 63 [B], 3213) without the addition of peroxide.

*Autoxidation.*—Oxygen combines in some degree with most olefins, and the ease of reaction increases with increase in unsaturation, and with increase in illumination; absorption of oxygen can, however, often occur slowly in the dark—thermally promoted. Normally the primary reaction products are peroxides, but as these are often unstable (especially at temperatures above room temperature) the products isolated are most often mere secondary oxidation products of the original olefin, the peroxides serving as oxidising agents. Olefins of the type  $\text{RCH}_2\text{CH:CHR}$  give hydroperoxides  $\text{RCH}(\text{OOH})\text{CH:CHR}$ , which undergo secondary reaction (intramolecular or intermolecular) to form numerous oxygeno-compounds, including unsaturated alcohols,

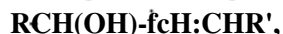

epoxy-compounds



double-bond cleavage products and polymeric derivatives (Farmer and Sundralingham, J.G.S. 1942, 121; Farmer and Sutton, *ibid.*, p. 139). Ethylene reacts only on being heated with oxygen, the oxygenated products containing but little undecomposed peroxide; *cis*-diphenylethylene gives highly polymerised peroxides,  $\text{C}_6\text{H}_5\text{CH}_2\text{OO-C}_6\text{H}_4\text{-CH}_2\text{OO}$ ; styrene absorbs a little oxygen and rapidly polymerises, unless a polymerisation-inhibitor is employed. The substitutive peroxidation characterising ethylenes and unconjugated polyolefins in contrast to the terminally additive (usually polymerisable) peroxidation characterising conjugated olefins (see Farmer, Trans. Faraday Soc. 1946, 42, 228). The absorption of oxygen by olefins is often greatly accelerated by the presence of organic and inorganic salts of iron, copper, cobalt, manganese, and lead, also by finely divided nickel; certain of these salts influence the decomposition of peroxides.

Di-olefins and Polyolefins. See

OLEFINS, Vol. II, 856; II, 151a, 1566.

Cyclic Mono-, Di-, and Poly-olefins. See CYCLENES, Vol. III, 532a, 5346.

E. H. F.

**OLEO-RESINS.** The oleo-resins constitute a large group of natural products, the chief constituents of which are volatile oil and resin. The essential oil may be separated by steam distillation or distillation under reduced pressure, the remaining resinous portion forming a solid or semi-solid mass, usually of a sticky consistency.

The more important natural oleo-resins, frequently known as balsams, comprise the following: (1) Balsam of Peru, (2) Canada Balsam, (3) Chian Turpentine, (4) Copaiba Balsam, (5) Elemi, (6) Gurjun Balsam, (7) Ladanum (Labdanum), (8) Mecca Balsam (Balm of Gilead), (9) Turpentine, (10) Venice Turpentine. In addition to these, there are galeical products used in medicine, prepared from raw materials by extraction with solvents, the chief of which are: (11) Capsicine (Oleo-resin of Capsicum), (12) Oleo-resin of Cubeb, (13) Gingerine (Oleo-resin of Ginger), (14) Malefern Extract, also known as Oil of Malefern, (15) Oleo-resin of *Farolay*.

In the following brief description of these oleo-resins, the relevant reference only is given of those already described in earlier volumes of the Dictionary.

(1) Balsam of Peru (v. Vol. I, 6165).

(2) Canada Balsam (Canada Turpentine) (v. Vol. II, 261a).

(3) Chian Turpentine is the turpentine derived from a small tree *Pistacia terebinthus* Linn., which inhabits the shores of the Mediterranean and Asia Minor. It was formerly used in medicine but is not now recognised in this country as of any particular value.

(4) Copaiba Balsam (v. Vol. III, 3376, 338):

(6) Elemi (v. Vol. IV, 275a).

(6) Gurjun Balsam, also known as wood oil but not to be confounded with Chinese Wood Oil which is an entirely different product. Gurjun Balsam is the product of various species of *Dipterocarpus* and it is obtained in Burma. It is used as a substitute for and as an adulterant of Copaiba which it resembles in appearance (v. Vol. III, 337(2)).

(7) Ladanum (Labdanum) (v. Vol. VII, 1754)

(8) Mecca Balsam (Balm of Gilead) (v. Vol. VII, 545d).

(9) Turpentine (v. Vol. VII, 545d).—The oleo-resinous exudation from various species of conifer. It is by far the most important member of the group of oleo-resins and is widely used as the source of oil of turpentine employed in paints and varnishes as well as for medicinal purposes. A full description of its characters, chemistry, and uses will be given in a later volume of this Dictionary. Various types of turpentine are known under descriptive names such as Venice Turpentine (v. *infra*), Strassburg Turpentine, Hungarian Turpentine, Greek Turpentine, Himalayan Turpentine, Jura Turpentine, etc.

(10) Venice Turpentine (Larch turpentine).

—The natural exudation from the bark of

*harix decidua* Mill, chiefly obtained from the Tyrol. The analytical constituents are as follows: acid value 64-77, saponification value 97-133, iodine value about 148, acetyl ester value 109-119. Much of the so-called Venice turpentine sold in commerce is a factitious article consisting of colophony, resin oil, and oil of turpentine.

## GALENICAL OLEO-RESINS.

(11) Capsicine.—Oleo-resin of Capsicum (v. Vol. II, 2736, 2756).

Capsicine contains essential of resins, and a crystalline substance, *capsaicin*, which is the pungent principle. Capsaicin, m.p. 64-65°, consists of *ij*-methyl-*J*<sup>c</sup>-nonenylvanillylamide:

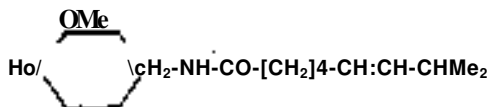

(Nelson and Dawson, J. Amer. Chem. Soc. 1923, 45, 2179; Späth and Darling, Ber. 1930, 63 [B], 737). Capsicine has *p* 0.925-0.940 and *n*<sup>D</sup> 1.465-1.479. The acid value varies from 90-120 when alcohol is used and from 100-110 when ether or acetone is used.

(12) Oleo-resin of Cubebs.—Prepared by extracting with ether the powdered dried unripe fruits of *Piper cubeba* Linn., Fam. Piperaceae. It is a green viscid liquid with a strong peppery odour and contains a volatile oil (v. *CUBEBS*, ESSENTIAL OIL OF, Vol. III, 455c), a fatty oil, several resins of undetermined composition, and *cubebin*.

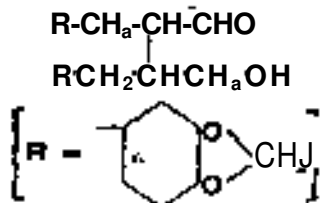

(Haworth and Kelly, J.C.S. 1937, 384), which crystallises in slender prisms, m.p. 132°, [*α*]<sub>D</sub><sup>20</sup> -17.1°, *semicarbazone*, m.p. 144°. The yield from the drug varies from 10-30%, the specific gravity from 0.985-1.020, and the refractive index from 1.500-1.501. It is used in medicine as an internal antiseptic in gonorrhoea and in the form of lozenges as an expectorant and stimulant to the bronchial mucous membrane.

(13) Oleo-resin of Ginger.—Gingerine. Prepared by extracting with acetone, alcohol, or ether the dried rhizome of *Zingiber officinale* Roscoe, Fam. Zingiberaceae. Ginger rhizome is cultivated in the West Indies, Africa, Java, and other tropical countries.

The oleo-resin is used medicinally as a stomachic and is sometimes added to purgatives to prevent griping. It is also used as a flavouring agent.

Gingerine has *n*<sub>D</sub><sup>20</sup> 1.026-1.045, *n*<sub>D</sub><sup>15</sup> 1.515-1.525. The pungent constituent is gingerol (v. *GINGER*, Vol. V, 533). To estimate the gingerol about 1 g. is extracted several times with light petroleum, which is then evaporated; the residue is dissolved in 60% alcohol and the alcohol and the alcoholic solution extracted

with light petroleum. The alcohol is then evaporated and the residue extracted three times with ether; the ether is evaporated and the gingerol weighed. Gingerol rapidly loses its pungency when warmed with 2% sodium hydroxide. It is a mixture of homologous phenolic substances. The volatile oil of ginger has no pungent properties (v. *GINGER*, ESSENTIAL OIL OF, Vol. V, 555d).

(14) Oleo-resin of Malefern (v. Vol. V, 180<sup>a</sup>-182(2)).

(15) Oleo-resin of Parsley, also known as ApioL It is prepared by extraction with alcohol or ether from the fruits of *Carum petroselinum* Benth. et Hook, Fam. Umbelliferae. It is official in the British Pharmaceutical Codex under the title ApioL. It is a green oily liquid, *p* 1.055-1.091, having a peculiar odour and a disagreeable acid taster. It is used medicinally in dysmenorrhoea and amenorrhoea and as a diuretic. It is a polyphenol (1-allyl-2:5-dimethoxy-3:4-methylenedioxybenzene) which occurs in acicular crystals, m.p. 29-30°, having an odour of parsley. ApioL dissolves in sulphuric acid giving a characteristic blood-red colour.

C. T. B.

## OLIGOCLASE v. FELSAB.

OLIVE. The fruit of *Olea europaea* L., is used mainly as a source of olive oil and also for table use. For the latter purpose it is commonly conserved by pickling in brine.

The fruit, of which a number of varieties are marketed, consists approximately of seed 2-5, stone 17, and flesh 80% by weight. The following is typical of chemical analyses:

	Water.	Protein.	Fat.	Carbohydrate and fibre.	Ash.
Flesh .	30.1	8.2	51.9	10.5	2.3
Stone .	9.2	3.5	8.8	83.3	1.1
Seed .	10.6	18.6	31.9	36.7	2.2

American analyses of pickled olives as quoted by Winton ("Analysis of Fruits," 1945)\* are:

	Water.	Protein.	Fat.	Carbohydrate and fibre.	Ash.
Green .	58.0	1.1	27.6	11.6	1.7
Ripe .	64.7	1.7	25.9	4.3	3.4

The percentage composition of the mash of olives is:

Ash.	K <sub>2</sub> O.	Nm <sub>2</sub> O.	CaO.	MgO.	Fe <sub>2</sub> O <sub>3</sub> .
Flesh	50.0	7.5	7.5	0.2	0.7
Stone	58.8	6.6	7.5	0.4	0.8
Seed	30.3	20	30.4	1.2	0.1

Ash.	P <sub>2</sub> O <sub>5</sub> .	SO <sub>3</sub> .	SiO <sub>2</sub> .	Cl.
Flesh	1.3	1.1	0.7	0.2
Stone	16.7	3.3	1.3	4.7
Seed	28.2	2.4	6.4	0.1

Olives are usually pickled in brine to which 1% of acetic or lactic acid is added. Lactic acid is said to impart a better flavour to the fruit. During pickling olives tend to darken to a brownish colour, a certain amount of acid fermentation taking place. *Lactobacillus* cultures improve the colour and appearance of the pickled fruit. Addition of sodium benzoate improves the conservation of olives. W. V. Cfuess *et al.* (Fruit Products J. 1941, 21, 113) in a discussion of pickling and processing of olives records promising results of "frozen storage" methods for conserving olives.

Olives contain a glucoside *oleo-europein* which is hydrolysed by emulsin (present in fruit, leaves, and bark) yielding glucose (Power and Tu#n, J.C.S. 1908, 93, 891, 904; Pharm. J. 1908, [iv], 27, JJ^j

Finely ground olive stones have been used to adulterate pepper. This adulteration is commonly detected by the red colour formed on treating the sample with hot di-nitro-phenylenediamine. The test is said not to be specific and B. Paris (Bull. Sci. Pharmacol. 1941, 48, 17) recommends the use of phloroglucinol in hydrochloric acid which produces a red coloration in the lignified tissue of the olive stones. Bottled olives are said to contain approximately 1,000 international Units of vitamin-4 per 100 g.

A. G. Po.

OLIVE OIL is obtained from the fruit of the olive tree *Olea europaea* (sativa) L., which thrives best in a sub-tropical climate and is cultivated extensively in all the countries bordering the Mediterranean. It is also cultivated in Australia, South Africa, and California, but cultivation in India has so far proved unsuccessful since, although the tree grows and flowers, the fruit seldom reach maturity. The tree normally begins bearing at 8-10 years, the greatest yield of fruit is obtained about 20 years, the tree bearing fruit for over 100 years, each tree yielding between 30 and 200 kg. of olives a season. The weight of individual olives varies from 2-10 g., the kernel being about 50% of the whole for small fruit, diminishing to under 10% in the largest. In the best cultivated types fruits weigh from 2 to 6 g., the kernel being 10-30%. The oil content of the fruit rises to a maximum when the fruits are fully ripe and then decreases slowly, the fleshy pericarp of the best cultivated fruit containing 40-60% of oil as compared with 10-30% for Algerian and Californian fruit.

The best oils are obtained from hand-picked fruit put by crushing in a mill without breaking the kernels, or by peeling hand-picked fruit and ~~pressing slightly~~ after removal of the kernels, ~~The crushed~~ maro is then pressed in a hydraulic press of the "Marseilles" type to a pressure of 400 atm., yielding the best edible or "virgin olive-oil." A further yield of oil is obtained by pouring cold water on to the maro after the pressure has been released, and repressing.

The pulp is then removed from the press, mixed with hot water and again pressed, when ~~oil~~ primarily used for soap-making, lubricating and illuminating, is obtained. The pulp, which contains 10-20% of oil, is beaten with hot

water, ground in special mills, and the water separated. The emulsion of oil and tissue is then hot-pressed, the oil, "huile de ressource," being allowed to stand at an elevated temperature, when a clear layer separates on the top over a layer of thicker oil, "olive oil grease." The oil cake remaining is then solvent extracted.

Fermentation of the marc in pits is an alternative to boiling with water, the oil set free, "huile d'enfer," frequently containing 60-70% of free fatty acids, being skimmed off.

In the more modern methods of extraction the fruits are broken up in stone-edge running mills and the pulp and seeds placed in specially constructed iron cage presses or fed continuously in an expeller press. Alternatively a centrifugal process is employed in which the pulped fruits are pressed through a wire screen to remove the seeds, the pulp being centrifuged. By either of these methods 60-70% of the oil present is recovered as first-grade quality in one operation, second-grade oil being obtained by solvent extraction of the residual marc. Such oils are termed "sulphur olive-oils" although solvents other than carbon disulphide, viz. light petroleum and trichloroethylene, are frequently used. Sulphur olive-oils are thick liquids, dark green in colour due to extracted chlorophyll.

The finest grades of olive oil require only filtration. Mucilage and vegetable tissue escaping into the oil are removed by settling in tanks, either alone, after boiling with water or brine, or after injecting a current of steam, the clear oil being drawn off from above the settleings. Oils which contain a higher percentage of free fatty acids, and which are darker in colour, are alkali refined, bleached, and deodorised, the olive aroma being re-introduced by adding a small quantity of crude oil to the refined product. For oils with a higher free fatty-acid content, the free fatty-acids can be removed by distillation. Sulphur olive-oils are refined by first removing the mucilage, but the product cannot be satisfactorily alkali-refined since the soap-stock contains approximately half its weight of neutral oil. Part of the free acidity is therefore removed by distillation, the residue being alkali-refined.

The finest grades of olive oil vary from yellow to greenish-yellow in colour, second grades green to brownish-green, usually clear and limpid; extracted oils are cloudy, viscous, and offensive-smelling.

The following physical and chemical characteristics have been recorded:  $n_D^{20}$  1.471, setting-point below 0°, saponification value 180-195, iodine number 80-85, acetyl value 5-11, free fatty-acids as oleic 1-10% (sulphur olive-oil 10-70%), unsaponifiable matter 0.5-1.5%.

Olive oils appear to fall into two distinct types. All except those from the Mediterranean islands and from Tunisia resemble one another in containing approximately 9-10% palmitic, 2% stearic, not more than 7% linoleic, and 80% oleic acid (G. S. Jamieson and W. F. Baughman, Oil and Fat Ind. 1925, 2, 40, 110; *ibid.* 1927, 4, 426; T. P. Hilditch and E. C. Jones, J.C.S.

1032, 805; T. P. Hilditch and H. M. Thompson, J.S.C.I., 1937, 56, 434; B. G. Gunde and T. P. Hilditch, *ibid.* 1940, 59, 47; T. P. Hilditch and L. Maddison, *ibid.* 1941, 60, 258). These oils, from Italy (earlier type), Spain, Palestine, and California are so similar in composition that for the acids mentioned variations are almost within experimental error. The Mediterranean islands and Tunisian oils (V. Brandonisio, Chim. e. l'Ind. 1936, 18, 14; G. S. Jamieson, B. M. Hann, and W. F. Baughman, Oil and Fat Ind. 1927, 4, 63), and a more recent sample of Italian (Tuscany) oil (B. G. Gunde and T. P. Hilditch, *l.c.*; T. P. Hilditch and L. Maddison, *Z.c.*), contain 15% or more palmitic, 10-13% linoleic, and about 70% oleic acid, this possibly indicating that olive oil of somewhat different composition from the typical earlier olive oils is being produced in recently developed areas.

Considering the earlier type of Italian oils, since the component fatty-acid contents are constant, it follows that the component glyceride contents must be very similar. Triolein occurs to the extent of 30%, monolinoleodiolein 25%, and monosaturated dioleins 45% (mol.), in contrast to the oils of higher linoleic acid content which contain only about 5% (or less) triolein, with about 35% monolinoleodioleins, 5% monosaturated monolinoleo-oleins, and 35% saturated dioleins (Hilditch and Maddison, *l.c.*). The content of these glycerides in an olive oil is of some significance with regard to its suitability for packing or conveying of other edible products, *e.g.*, fish, vitamin concentrates, etc., and for use in textile industries, since the percentage of molecules containing the much more readily oxidisable linoleic acid is of the order of 40 as compared with 25 in the case of Palestinian olive oil (which can be regarded as typical of genuine oils of the earlier type).

The highest grades of olive oil are used for edible purposes, intermediate grades for the manufacture of textile oils and, together with the distilled acids obtained from high-acid oils, for high-grade soaps. The lowest grades of sulphur olive-oils are suitable for lower-grade toilet and Castile soap; a high-grade soap would result from such oils if the colour could be effectively removed.

Substitutes for olive oil, primarily used in textile industries, include slightly hydrogenated groundnut oil, reprocessed olive oils made from the distilled fatty acids of high-acid oils, or of high-acid oils esterified with glycerol. Olive oil fatty-acids esterified with *cyclohexanol* have also been used. A substitute for edible purposes is obtained by infusing a refined vegetable oil, cottonseed or groundnut oil, with 10% ground salted ripe olives (S. Musher, Oil and Soap, 1934, 20, 26).

On account of the relatively high price of olive oil it is frequently adulterated with teaseed oil, this being more difficult to detect than oils such as arachis, cottonseed, sesame, or rape oil. The undeclared blending of solvent extracted and expressed oils is considered to be fraudulent, detection of such blending often being difficult. Tests have been proposed (Amer. Oil Chem. Assoc. test, Oil and Fat Ind. 1931, 181, 197) for the detection of residual sulphur by blackening

of silver benzoate, but this fails in the case of highly refined carbon disulphide-extracted oils and those extracted with trichlorethylene. Bromophenol Blue has been used for detecting traces of alkali left in the oils after refining (A. Romeo, Olii miferali grassi e saponi colori e vernici, 1939, 19, 88). A further test depends on the fact that extracted oils give a persistent red colour with acetic anhydride and sulphuric acid (Fachini, Ind. olii, min. e grassi, 1930, 10, 9). Most virgin olive-oils show a yellow fluorescence in ultra-violet light, whereas refined oils, whether expressed or extracted, and most seed oils, give a blue fluorescence (Marcille, Ann. Falsif. 1928, 21, 189; Gisondi, B. Staz. Chim. Agrar Sperim Ro;na, 1931, publ. No. 276; Lucente, Atti X<sup>o</sup> cong. intern. chim. 1939, 4, 594). This however is not conclusive, since some seed oils give a yellow fluorescence, whilst unrefined expressed olive oils have been known to give a blue fluorescence. The high values for the iodine number of the unsaponifiable matter in olive oil (197-206) and the great difference between this and the lower values (117-124) for oils used as adulterants gives another useful method for detection of adulteration (Bolton and Williams, Analyst, 1930, 55, 5).

The residual cake has little or no feeding value on account of the high fibre content, and if fed the hard, sharp, broken pits may cause injury to the digestive tract.

M. L. M.

**OLIVENITE.** A basic copper arsenate,  $\text{Cu}_3(\text{AsO}_4)_2 \cdot \text{Cu}(\text{OH})_2$ , crystallised in the orthorhombic system. It forms small crystals of prismatic habit; or more usually globular aggregates of radiating needles, sometimes so fine that the material has a velvety appearance. The characteristic olive-green colour (hence the name) ranges from a dark shade in the crystals to pale or almost white in the finely fibrous masses; the latter variety is known as *wood-copper*, p 4-1-4-2. It was formerly found in some abundance in the upper workings of the copper mines near St. Day in Cornwall, and also in the Tintic district in Utah. In Cornwall it has resulted from the alteration of chalcopyrite and malachite, while in Utah the mother mineral was enargite ( $\text{Cu}_3\text{AsS}_4$ ). The arsenic is sometimes partly replaced by phosphorus, forming a passage to the isomorphous and very similar mineral *libethenite* ( $\text{Cu}_3(\text{PO}_4)_2 \cdot \text{Cu}(\text{OH})_2$ ) originally found at Libethen in Hungary.

L. J. S.

**OLIVER'S BARK** (*Black Sassafras*). The drug is the dry bark of *Cinnamomum oliveri*, a tree native in New South Wales and Queensland. The tincture prepared from it has carminative and antiseptic properties and is prescribed in Australia as a substitute for cinnamon (v. CINNAMON AND CASSIA, Vol. III, 182a). The active principle of the bark is the essential oil, which contains  $\alpha$ -camphor 18-20, eugenyl methyl ether 40-45, pinene 12-15, and saffrole 25-27% (Haifgreaves, J.C.S. 1916, 109, 751). This oil differs markedly in composition from essential oil of cinnamon (v. CINNAMON BARK, ESSENTIAL OIL OF, Vol. III, 183a; also Vol. VIII, 656c).

J. N. G.

**OLIVETORIC ACID** (v. Vol. VII, 294c).



**OLIVINE.** An abundant rock-forming mineral group, essentially silicates of magnesium and ferrous iron,  $(Mg,Fe)_aSiO_j$ . A complete isomorphous series exists ranging from forsterite,  $Mg_2SiO_4$  through chrysolite and hortonolite to fayalite,  $Fe_2SiO_4$ . Olivines are richer in magnesium than in iron, approximating to chrysolite in composition. \*Nickel and titanium are frequently present in minute quantities. The olivines crystallise in the orthorhombic system; well-formed crystals are rare, and the mineral usually occurs as granular masses or as disseminated glassy grains. Forsterite is colourless or pale yellowish-green, but with increasing iron the colour deepens through olive-green to reddish-brown or even black in fayalite. Crystals are transparent to translucent, with a distinctive vitreous lustre,  $n_p$  3.2—4.3, increasing concomitantly with iron; hardness 6.5—7. The mineral is slowly soluble in hydrochloric acid, yielding gelatinous silica upon evaporation. Individual members of the olivine group can be distinguished by accurate determination of refractive indices, optic axial angles, and density. By weathering, the olivine readily alters to serpentine, with iron oxides, magnesite, opal, and piemontite as possible accessories. UV products of decomposition. Forsterite is typically found in thermally metamorphosed dolomitic limestones, and occasionally in basic igneous rocks; fayalite is uncommon as a naturally occurring mineral, but is an abundant silicate constituent found crystallised in many metallurgical slags. Common olivine is of widespread occurrence in many basic and ultrabasic igneous rocks such as gabbro, basalt, and peridotite, the rock known as *dunite* being composed almost wholly of olivine. The mineral is also an important constituent of stony meteorites. Valuable deposits of chromite, diamond, nickel, and platinum are typically associated with olivine-rich igneous rocks.

The transparent olive-green variety of olivine, *peridot*, and the clear yellowish-green variety, *chrysolite*, rank as semi-precious gemstones. Peridot comes mainly from St. John's Island in the Red Sea, and is also collected from gravels in Arizona and New Mexico. Olivine has recently acquired considerable importance as a basic refractory material. It serves well in lining and reheating furnaces, as the back wall and roof of open-hearth steel furnaces, and above the slag line in the walls and arched roofs of non-ferrous furnaces. The best natural material for making olivine bricks is the rock *dunite*, which contains about 40% of silica, 30% of magnesia, and 6% of ferrous oxide. The larger the proportion of forsterite the rock contains the better will be its quality, because pure forsterite melts at 1,910°C, has a high refractoriness under load, and adequate crushing strength when cold. The cheap artificial or synthetic "forsterite" brick, which has excellent refractory qualities, can be produced in several ways, e.g., by mixing olivine with magnesia, or talc with magnesia, or magnesite with silica rock. Good olivine bricks contain approximately MgO 57, SiO<sub>2</sub> 31, FeO 6, and CaO 4%; they have a bulk-density of 2.5, and a true density of 3.3. They are almost neutral

in reaction at high temperatures, but in the presence of slag and flue-dust they may react with silica bricks and fireclay bricks. Bricks composed of olivine and chromite are more refractory under load than ordinary chromite bricks. Olivine is marketed in moulded bricks and in cut blocks of dunite. It is likely to rival dead-burned magnesite as a refractory, especially as it can be produced more cheaply. About 4,500 tons of natural olivine were used for refractory purposes in the United States in 1941. A small quantity of the mineral was employed in the production of Epsom salts (MgSO<sub>4</sub>). Olivine is also a potential source of magnesia, for making metallic magnesium.

*References.*—A. B. Snare, "Refractory Materials: their Manufacture and Uses," 3rd ed., London, 1941; 3, T. Tomkiewitz, "Zoned Olivines and their Petrogenetic Significance," *Min. Mag.*, (ii) 39, 26, 229.

D. W.

**ONION (*Allium cepa* L.).** The edible onion bulb consists of an axial arrangement of fleshy scales which form the leaf bases of the growing plant. The bulbs of the common onion normally develop singly from seed in one season. Other varieties, e.g., shallots, *A. ascalonicum*, are propagated by planting single mature bulbs which divide and produce clusters of 4-10 new bulbs. Others again, e.g., perennial or "tree" onions, may or may not flower but produce young bulblets on aerial stems. The bulblets may be used for culinary purposes or allowed to mature and planted again for further propagation. The "Welsh" onion, *A. fistulosum*, forms a cluster of thickened blanched leaf bases but no actual bulb as in the common onion. Recorded analyses show the average percentage composition of onions to be:

	Water.	Protein.	fat.	N-free extract.	Fibre.	Ash.
1 Common onion (red) mature	92.1	1.1	0.3	5.6	0.7	0.5
1 Common onion (white) mature	80.5	1.7	0.2	10.0	0.7	0.6
1 Tree onion	81.5	2.1	0.24	14.7	0.7	0.7
1 Onion bulbs	80.2	1.1	0.12	8.8	0.7	0.5
1 Edible tops	82.5	1.34	0.29	10.0	0.9	1.0
1 Young onion (whole)	89.1	1.27	0.34	11.7	1.8	0.8

1 U.S. Dept. Agr. Kept. 1881-82, 655: 1883, 2\*0.

2 New York Agric. Exp. St. Rept. 1883, 161.

3 von Schleitz, *Landw. Jahrb.* 101S, 62, 151.

4 *Agrochim. Philippine J. Sci.* 1016, 11, 01.

A. Kihara (*J. Agric. Chem. Soc. Japan*, 1B34, 10, 417) also records analyses of bulbs of *Allium* species and varieties not commonly known in his country.

The pungent volatile oil of onions consists largely of allyl propyl disulphide,  $C_6H_{12}S_2$ , together with a small proportion of a higher sulphide (F. W. Semmler, *Arch. Pharm.* 1892, 230, 443) and a very small amount of a substance apparently identical with the higher-boiling fraction of oil of asafoetida. The oil

content or "pungency" of onions may be determined in several ways on the assumption that the essential constituents are all of the disulphide (FT—S—S—R") type. Thus W. H. Paterson (J. Amer. Ghem. Soc. 1914, 36, 1290) distils the fresh material and collects the distillate in copper oxide, the copper sulphate formed being subsequently determined as barium sulphate. H. Platenius (J. Agric. Res, 1935, 51, 847) hydrolyses the material with acid and distils in steam, oxidising the distillate with bromine water and precipitating the sulphur as barium sulphate. The American Association of Official Agricultural Chemists recently adopted the Gros-Pichon method (J.Pharm. Chim. 1934,19, 249) in which the volatile matter is distilled into ammoniacal silver nitrate, excess of which is ascertained volumetrically after removal of silver sulphid\* by filtration. Alternatively the volatile sulphur may be extracted with water, the extract being hydrolysed with acid, reduced with zinc dust, and treated with p-aminodimethylaniline to form Methylene Blue.

The carbohydrate constituents of onions have not been examined extensively. The total sugar content ranges from 2\*5-8% in different varieties, and changes but little during storage. E. Bennett (Proo. Amer. Soc Hort. Sci. 1941, 39, 293) reports a maximum loss of only 8% of the carbohydrate during storage for 3J months. Kihara (Lc.) records the presence of scorodose in *A. acorodopraaum* and of fructane in other varieties. Inulin and mannitol, but not dextrin, have also been detected. Wittmann {, landw. Oesterr, 1901, 4, 131) found 0.25% of pentoses in onions. The phytin content of onions appears to be high, Bagoisan (Philippin Agric, 1932, 31, 53) finding 4.7% in the dry matter.

A. L. Winton, "Structure and Composition of Foods," Vol. II, quotes the percentage mineral composition of fresh onions: water, 86, 89; total ash, 0.7, 0.5; K<sub>2</sub>O, 0.25, 0.18; Na<sub>2</sub>O, 0.02, 0.01; CaO, 0.16, 0.04; MgO, 0.03, 0.02; P<sub>2</sub>O<sub>5</sub>, 0.13, 0.07; SO<sub>3</sub>, 0.04; SiO<sub>2</sub>, 0.07; Cl, 0.02. Among "trace" elements reported are the following: Fe, 150; Al, 90; Mn, 60; Cu, 11; Zn, 2.4 mg. per kg. dry matter.

The vitamin contents of onions have been examined by a number of analysts, Average values & e: thiamin 24-33 fig., riboflavin 123 pg, nicotinic acid 0.77 mg., ascorbic acid 14.5-1 f.4 mg per 100 g. of fresh material. Storage of onions in pits involves little loss of ascorbic acid (G. L. Dernovskaya-Zelentsova *et al.*, Proc. Sci. Inst. Vitamin. Res. U.S.S.E. 1941, 3, 276), but on cooking about 25% of the total ascorbic acid passes into the cooking water.

A. G. Po.

ONOFRITE (v. Vol. VII, 562d).

ONONIN (v. Vol. VI, 92d).

ONONIS ROOT. *Rest harrow. Ononis apinoaa* (Fam. Papilionaceae). A common European plant; the extract of the root is prescribed as a diuretic. It contains the flavone glucoside *onanin* (Vol. V, 259c; VI, 92cZ), a triterpenediol, *onoceryl* or *onocerin* (Zimmermann, A. 1941, U, 73), and a saponin (Wagner, Amer. Chem. Abstr. 1941, 35, 3032).

J. N. G.

ONOSMA ECHIOIDES Linn., i\* a biennial plant frequent throughout the Western Himalaya from Kashmir to Kumaon; it is widely distributed from Siberia and Cabul to France. The root is used in the Punjab Himalaya and Trans-Indus region as a red dye for wool. It is also utilised as a substitute for alkanet (*Anchusa tinctoria*) and imparts a rich red colour to medicinal oils and fats, e.g., Macassar *dft.* In Nepal the roots are boiled with oil and used<sup>4</sup> as a hair dye. The bruised root, leaves, and flowers are employed medicinally (Watt, "Dictionary of the Economic Products of India," 1891, 5, 487).

The dye is readily extracted from the violet-colored roots with alcohol, but is very sparingly soluble in water. The general properties and colour reactions of the dye are very similar to those of alkanet, and there can be little doubt that it contains either the same or closely allied colouring matters\* (Perjkin \*and Everest, "The Natural\* Organic Colouring Matters," 1918, p. 73).

E. J. G.

ONSAGEREQUATION. This equation (Onsager; Physikal. Z. 1926, 27, 388; 1927, 28, 277) gave the first quantitatively satisfactory theoretical interpretation of the variation with concentration of the equivalent conductivity of a strong, completely dissociated electrolyte. It is based upon the inter-ionic attraction theory, the main postulates of which are due to Debye and Hückel (*ibid.* 1923, 24, 185, 305, 334). For the mobility of an ion (i.e., the contribution of one ionic constituent to the total equivalent conductivity) the equation is

$$l = l_0 - \left[ \frac{(0.9854 \times 10^9) z^2}{(DT)^{3/2}} + \frac{28.94 z^2}{(DT)^{1/2}} \right] \sqrt{(z^+ + z^-)C} \quad (1)$$

where  $l$  and  $l_0$  are the ion conductances of the ion of valency  $z$  at concentrations  $C$  and zero, respectively,  $z^+$  and  $z^-$  are the valencies of cation and anion, and  $D$  and  $\eta$  are the dielectric constant and viscosity of the solvent at the absolute temperature  $T$ . Also,

$$w = z^+ z^- \{ 2g / (1 + \sqrt{g}) \},$$

where

$$g = \frac{z^+ z^- (l_0^+ + l_0^-)}{(z^+ + z^-)(z^+ l_0^+ + z^- l_0^-)}$$

For the total equivalent conductivity of a univalent electrolyte, the Onsager equation becomes

$$A - A_0 = \left[ \frac{8.147 \times 10^9}{(2T)^{3/2}} A_0 + \frac{40.93}{(DT)^{1/2}} \right] \sqrt{C} \quad (2)$$

and if the solvent is water at 25°C, r

$$A - A_0 = (0.2273 A_0 + 50.78) \sqrt{C} \quad (3)$$

The equation is seen to be of the same form as the "square root law" found empirically for strong electrolytes by Kohlrausch (Ann. Phys. Ghem. 1885, [ii], 26, 161; 1893, [ii], 50, 385; Z. Elektrochem. 1907, 13, 333). The derivation of the mathematical theory is beyond the scope of the present article (for reviews, see Williams and Falkenhagen, Ghem. Reviews, 1929, 6, 317; Falkenhagen, Rev. Modern Physics, 1931, 3,

412), but the qualitative aspects of the theory are readily understood.

Because of the electrostatic interaction between the ions, which diminishes in effect as the separation of the ions from each other increases with dilution, the arrangement of the ions in solution is not entirely random, but each ion tends to be surrounded by an "atmosphere" of ions of the opposite charge. This ionic atmosphere is entirely statistical in nature and represents only a small fractional degree of order as compared with the complete disorder appertaining to the molecules in solution of an uncharged solute. The effect is entirely reciprocal; each positive ion has a negative atmosphere and each negative ion has a positive atmosphere.

Onsager's theory is concerned with the effect of the imposition of a uniform electric field upon this "stationary" state. Consider a given ion moving under the influence of the applied field: it proceeds, its ionic atmosphere must be constantly renewed and this is a process which occupies a finite period of time, called the "time of relaxation." The atmosphere therefore lags behind the central ion and this asymmetry is electrically equivalent to a centre of opposite potential situated behind the central ion, which must therefore suffer a retarding force. It is clear that this "relaxation effect" will depend upon the mobilities of the ions concerned, since a swiftly moving ion can help to build up an atmosphere more quickly than a slower moving one. It will also depend upon the concentration, and the first term in the coefficient of  $\kappa^2/C$  in the Onsager equation, which expresses this effect, is seen to conform with these qualitative conclusions.

There is a second effect which causes a reduction in the ionic mobility, the "electrophoretic effect," expressed in the second term in the coefficient of  $\kappa^2/C$ . Since the ions exert a polarising influence on the solvent molecules, they carry a certain amount of solvent with them in their motion through the solution. Since a given ion is surrounded by an atmosphere of ions which are moving in the opposite direction, it must therefore be subjected to an additional retardation due to an unfavourable counter-flow of solvent, which will be additional to the ordinary viscous resistance to the motion.

If these terms, the various forces acting upon an ion moving with a steady velocity were summed algebraically in the Debye and Huckel treatment:

$$\text{Outside applied electric force} + \text{electric force of relaxation} = \text{frictional resistance of medium} + \text{frictional force of electrophoretic effect.}$$

Onsager's improvement on the original treatment consisted in the elimination of the ionic radius as an essential parameter in the calculation, in taking account of the Brownian movement of the ions, and in allowing for the mutual effect of the relaxation of both ionic atmospheres on each other.

Validity of Onsager's Equation for Aqueous Solutions.—The derivation of the equation involved a number of simplifying assumptions and mathematical approximations, such that it could only be expected to apply

as a limiting law to very dilute solutions. Tests of the equation must therefore involve extremely accurate conductivity measurements extending into the range of very low concentrations and only modern data suffice. The satisfactory nature of the agreement between the equation and experimental results for electrolytes of different valency type is shown in Figs. 1 and 2, which incorporate data due to Shedlovsky (J. Amer. Chem. Soc. 1932, 54, 1411), Shedlovsky, Brown, and MacInnes (Trans. Electrochem. Soc. 1934, 66, 165), Shedlovsky and Brown (J. Amer. Chem. Soc. 1934, 56, 1066), Jones and Bickford (Und. 1934, 56, 002), and Shedlovsky (quoted by D. A. MacInnes "Principles of Electrochemistry," New York, 1939, p. 331): the points are experimental and the lines are those predicted by the equation.

The equation can also be tested by altering it from the form  $A = A_0 - (aA_0 + p)\kappa^2/C$  into

$$A_0 = (A + \beta\sqrt{C}) / (1 - \alpha\sqrt{C}) \quad \dots (4)$$

which can be used to calculate  $A_0$  from each experimental  $A$  value. The results of such a calculation are shown in the following table, for the case of potassium chloride solutions at 25°C.

$\kappa \times 10^3$	Observed $A$	Calculated $A_0$
0.3-57G	140.37	140.91
1.0445	148.96	140.92
2.0570	148.42	149.00
3.3277	148.23	140.94
3.6217	148.10	140.92
4.6948	147.03	149.07
6.0895	147.50	149.07
8.4200	147.27	150.00
0.2856	147.11	149.07
11.321	145.80	149.07
14.080	140.50	150.02
15.959	146.30	130.06
20.291	145.76	149.99
23.370	145.52	100.06
27.848	u : : : .	150.00
32.827	144.68	150.06

It will be seen that the equation holds very satisfactorily, tending to show slight deviations at molar concentrations above about 0.0016.

Application to Non-aqueous Solutions.—In general, there is a satisfactory mass of conductivity data which conforms well with the equation, but deviations are frequently found; although the linearity of the  $A/\sqrt{C}$  plot is often preserved, the slope does not agree with the theoretical, the deviation usually being positive.

Uses of the Onsager Equation.

1. *Calculation of  $A_0$  Values.*—The equation provides the best means for the extrapolation of conductivity measurements on strong electrolytes to zero concentration. This is of importance in the evaluation of dissociation constants of weak electrolytes: thus for a weak acid, HA, the value of  $(\lambda_0)_{HA}$  found from the relation

$$(\lambda_0)_{HA} = (\lambda_0)_{NaA} - (l_0)_{Na} + (l_0)_{H^+}$$

the last two terms being the known mobilities of the sodium and hydrogen ions and  $(\lambda_0)_{K^+A^-}$  being found by the extrapolation of conductivity data on the completely ionised sodium salt of the weak acid.

H

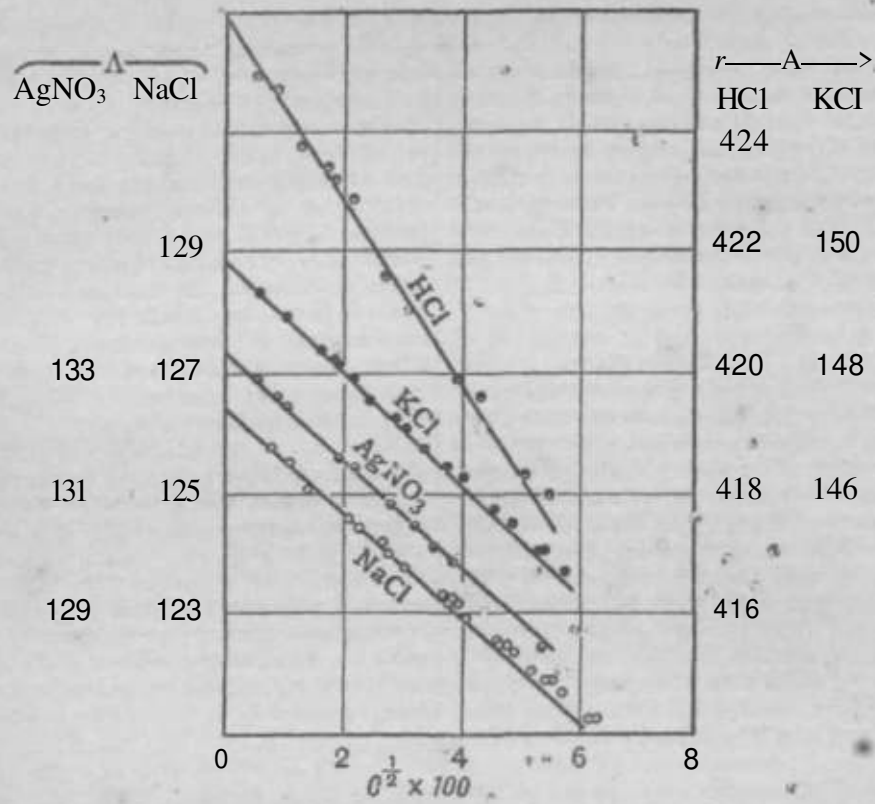

Fig. 1.

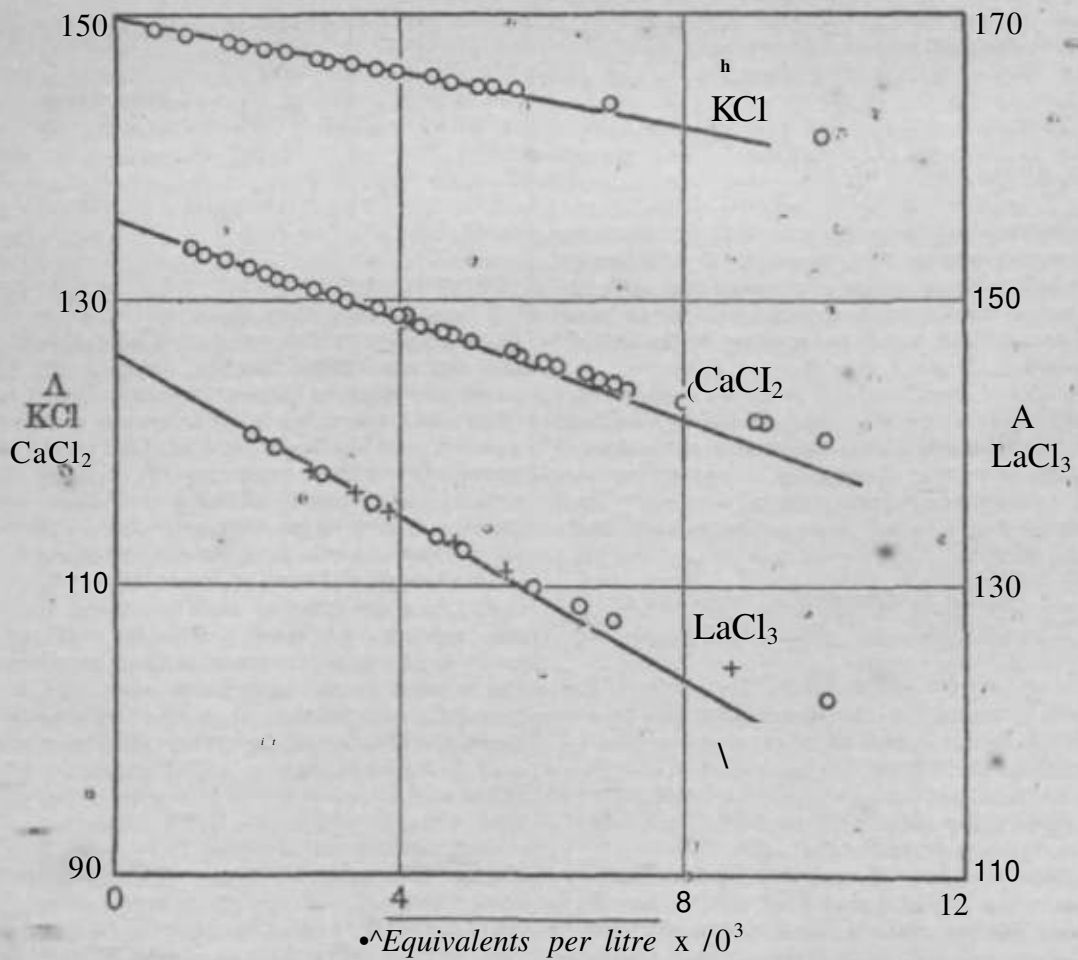

Fig. 2.

2. *The Calculation of True Degrees of Dissociation - of a Weak Electrolyte.*--The classical Arrhenius expression,  $a=A/A_0$  for the degree of dissociation assumes the constancy of ionic mobilities at all concentrations, which is now known to be erroneous.  $A_0$  must be replaced by  $A_{xf}$  where this is the sum of the ionic mobilities at the concentration to which the value of  $A$  relates. This quantity can be calculated by applying the Onsager equation to the ionised part of the weak electrolyte, so that

$$A_x = A_0 - (aA_0 + PWC) / d$$

where  $d = aC = (A/A_0)C$ . . . . . (6)

Extensions of the Onsager Equation.—The equation may be expected to fail at higher concentrations, not only because of the mathematical approximations involved in its derivation, but also because its constants are functions of the properties of the pure solvent, which are likely to be modified in solutions of appreciable ionic concentration.\* The only extensions which have been proposed and empirically confirmed (1.4.) found that the equation  $A = A_0 - (aA_0 + PWG + bC)$  where  $b$  is an empirical constant, gave agreement with experiment to somewhat higher concentrations, but Shed- JpvtViy (J. Amer. Chem. Soc. 1932, 54, 1405) found that

$$(A - A_0) / C = (aA_0 + PWG) / C + b$$

where  $B$  is a constant, gave better results.

By consideration of factors neglected in the simple derivation, further terms,  $DC \log C - EC^2$ , where  $D$  and  $E$  are further constants, were added (Onsager and Fuoss, J. Physical Chem. 1932, 56, 2689) which resulted in excellent agreement with experiment in some cases to quite high concentrations. Thus the equation  $W = 9.79 \sqrt{C} / (10 + 273 \sqrt{C})$   $\sim 149.86 + 141.90 + 29.24C \log (7.180 - 6(72$  (7)

expresses the equivalent conductivity of aqueous potassium chloride solutions at 25°C. with negligible error up to molar concentrations of 0.12. Such equations are not of very direct theoretical interest, but are of use as accurate interpolation equations.

**D. J. G. I.**

A variety of chalcedonic silica differing from agate only in the straightness and parallelism of its differently coloured layers, and so suitable for engraving as cameos. The alternate bands of colour are usually white and black, or white and red; in sardonyx they are

intense differences in colour, as now placed on the market, has been coloured artificially by chemical means (v. AQATB, Vol. 1, 163c).

**OOOLITE.** A rock composed principally of small spherical grains resembling the "hard roe" of fishes. The individual oolites are less than 2 mm. in diameter; the size of a pea. They are called oolites. Both oolites and pisolites are built up of "Wurtzite" layers, usually around a minute nucleus of matter. They commonly exhibit a radiating structure. Oolites and pisolites are generally composed of calcite.

dolomite, hematite/limonite, siderite, chamosite,<sup>0</sup> bauxite, phosphate, or silica. Sedimentary and residual rocks of any geological age may be characterised by oolitic structure. In this country oolitic limestones are best developed in the Jurassic system, and include such well-known, building stones as the Bath oolite and the Portland Stone. Oolitic hematite and limonite deposits constitute valuable iron ores in the Clinton area of the Appalachians, the Jurassic "minette" region of Luxembourg-Lorraine, etc\*; elsewhere, accumulations of oolitic siderite and chamosite are mined for their iron content. In many bauxite deposits the upper parts of the ore-bodies are characterised by distinctive oolitic and pisolitic structures.

**D. W.**

**OPAL,**  $SiO_2 \cdot nH_2O$ . An amorphous hydrated silica gel, with a variable water content rising to a maximum of 10%. It is commonly found in botryoidal and stalactitic forms, or as an infilling of cracks and cavities in certain volcanic and weathered sedimentary rocks. Opal is distinguished from fine-grained varieties of quartz by its inferior hardness (6-6) and lower specific gravity, which ranges from 1.9 to 2.3, mainly according to its water content. The colour of opal is variable, but mostly white, or pale shades of yellow, red, and green, and the mineral often displays milky or opalescent effects, on an iridescent play of colours.

Among the many varieties of opal are the clear and colourless *hyalite* or *water-opal*; the valuable *precious opal* (including the so-called *black opal*) which exhibits an internal play of vivid colours due to the interference of light reflected from the surfaces of thin curved cracks infilled with opal in a state of hydration different from that of the matrix; *fire opal*, with brilliant orange to red reflections; *wood opal*, representing silicified fossil wood. The best known localities for precious opal are Czerwenitz in Czechoslovakia, Queensland, and the New South Wales areas of White Cliffs and Lightning Ridge, the latter being famed for its black opals.

In addition to these compact forms of opal, there are also loose, friable forms such as *geyserite* or *siliceous sinter*, deposited by hot springs and geysers, as in Yellowstone Park in Wyoming, and *diatoyite* (v. Vol. III, 579a), a sedimentary deposit consisting of myriads of microscopically small siliceous skeletons of diatoms. Diatomite (also known as *diatomaceous earth*, *infusorial earth*, *kieselguhr*, or *tripolite*) is used extensively in filtration, especially in sugar-refining, and for filtering malt products, fruit juices, mineral oils, sewage, vitamin extracts, etc. In the form of powder or bricks, diatomite serves as an insulator in furnaces, refrigerators, and sound-proof rooms. It is also used as a light-weight filler in paints, rubber, plastics, etc., and as a mild abrasive in metal polishes. In 1938 the world production of diatomite exceeded 250,000 tons, of which the U.S.A. contributed over 100,000 tons (chiefly from California), and Denmark about 90,000 tons. The crude diatomite, which is usually dried and calcined before marketing, is sold in the form of sawed blocks, crushed aggregates, or powder.

OPIANIC ACID,  $C_{10}H_{10}O_5$  (positional isomers and pseudo-forms are known).

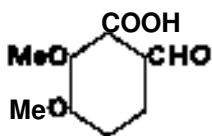

I.

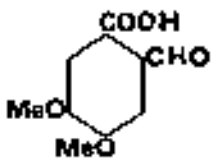

II.

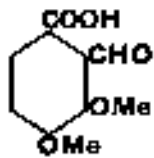

III.

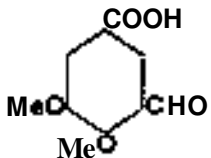

IV.

(I) *Opianic acid*, a-form, 5:6-dimethoxy-2-aldehydobenzoic acid, m.p.  $150^\circ$ , a fission product of narcotine and hydrastine, obtained by oxidation of these alkaloids. For its preparation, see Perkin *et al.*, J.C.S. 1925, 127, 197. The a-form exists in aqueous solution (Buu-Hoi, Amer. Chem. Abstr. 1942, 86, 6152). The pseudo-form of (I), m.p.  $121^\circ$ , has the structure

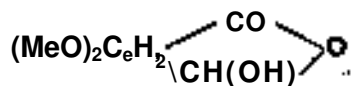

and exists in chloroform solution (Buu-Hoi, *ibid.*).

(II) *m-Opianic acid*, a-form, 4:5-dimethoxy-2-aldehydobenzoic acid, m.p.  $183-184^\circ$  (Perkin and Stoyler, J.C.S. 1923, 123, 3176).

(III) *Pseudo-opiadic acid*, a-form, 3:4-dimethoxy-2-aldehydobenzoic acid, m.p.  $121-122^\circ$  (Chakravarti *et al.*, Amer. Chem. Abstr. 1934, 28, 6720; J. Indian Chem. Soc. 1934, 11, 715).

(IV) *o-Opianic acid*, a-form, 4:5-dimethoxy-3-aldehydobenzoic acid, m.p.  $210-211^\circ$  (Perkin *et al.*, J.C.S. 1929, 193).

J. N. G.

OPIAURIN,  $C_{20}H_{18}O_{11}$ , a cherry-red amorphous dyestuff prepared by adding a mixture of phenol and opianic acid to concentrated sulphuric acid. Other aromatic aldehydes react similarly (Liebermann and Seidler, Ber. 1887, 20, 8<sup>^</sup>3). In presence of 16% sulphuric acid, a colourless product,  $C_{17}H_{14}O_8$ , is formed (Bistrzycki *et al.*, *ibid.* 1894, 27, 2632, Note 3).

J. N. G.

OPIUM. *Origin*.—Opium is the milky juice of the unripe capsules of *Papaver somniferum* Linn., obtained by incision and inspissated by evaporation. The plant probably originated somewhere in the countries bordering the Eastern Mediterranean, from whence it spread eastwards through Iran to India and China (Bentl. a. Trim. 18; Redlich, Apoth.-Ztg. 1928, 43, 603). The two most important varieties cultivated for the production of opium appear to be *glabrum*, with subglobular capsules and ten to twelve stigmata, and *album*, with egg-shaped capsules and without apertures (Boissier, Flora Orientalis, 1867, 1, 116). The former is grown in Asia Minor, and, until recently, in Egypt; and the latter is grown in Iran and India. A variety *nigrum*

appears also to be grown in Iran and the Balkans. Numerous minor distinctions exist. In the same variety the petals may be plain or fringed, and may be white, red, or violet, with a dark purplish spot at the base in most cases. The seeds may be white or dark-coloured, and contain from a third to a half of their weight of fixed oil. The capsules are provided with a lactiferous system from which the juice exudes when they are incised. This milky juice is present in the plant in all countries where it has been grown, and of course may be collected provided that the rainfall is not too great and the temperature is neither arctic nor entirely tropical. That its production has been confined for the most part to the countries named above was determined by other considerations, such as the value of land and the cost of labour.

*History*.—Certain of the pseudo-medical prescriptions in the Ebers Papyrus (ca. 1500 B.C.) contain the opium poppy as an ingredient. It is possible, though by no means certain, that the Egyptians recognised the medicinal value of the plant, although of course they did not extract opium in the modern sense of the word. It is strange that no further mention of the use of the poppy by the Egyptians appears to have come down to us until the thirteenth century (Simon Januensis). Indeed, from Theophrastus in the third century B.C. for a period of some 1,500 years the only variety of opium known in Europe was that derived from Asia Minor. Dioscorides, writing in the first century A.D., points out that two varieties of opium were used in his time. One of these, resembling the opium of to-day, was prepared by incising the capsules. The other, "meconium," was extracted from the entire plant by means of a solvent. Similar accounts may be found in the works of Pliny and other Latin writers. The nations of the East appear to have learned of opium from the Arabs, and it seems probable that the use of the drug was favoured by the Mohammedan prohibition of alcohol.

In classical times and in the Middle Ages "electuaries" and "theriacs" containing opium mixed with honey and spices were often employed. The alcoholic tincture of opium was first introduced by Sydenham in the latter part of the seventeenth century and in the next century appeared the powder bearing the name of Thomas Dover.

The first accounts of the production of opium in Persia did not reach Europe till the seventeenth century, although there is no doubt that the poppy was cultivated there much earlier. In India, cultivation is known to have been well established by the early sixteenth century. Opium was known in China at an early date but does not appear to have been largely cultivated at first, as the Chinese obtained most of their opium from India. The importation was small and was used almost exclusively as a remedy for dysentery. In the fifteenth century opium smoking was introduced, perhaps from the East Indies, and the habit had become widespread by 1800. The Chinese authorities were intermittently alarmed at the growth of opium-smoking and as early as 1729 issued an edict prohibiting the practice. Similar edicts followed



from, time to time directed against the growing of the poppy and the importation of opium. Meanwhile in India the opium monopoly passed in 1757, after Plassey, from the Moguls to the East India Company, under whose direction the opium traffic was intensified. It must be admitted, however, that the policy of the central, Chinese government was not consistent, nor was it always backed up loyally by the local authorities. In 1839, however, it was decided to enforce the law and a £2,000,000 stock of opium was destroyed by the Chinese. This, together with more legitimate complaints relative to restrictions placed on general trade, led to a war which terminated in the Treaty of Nanking in 1842, a result of which was the opening of certain ports to foreign trade. The importation of opium was resumed, the amounts increasing until about 1880, when a steady fall began owing to the expansion of Chinese home production. By 1882 the production in various provinces only, Szechuen and Yunnan, was estimated as more than twice the whole Indian importation (Pharm. J., 1883, [in], 13, 225; *c.* J.S.P. 1.188&, 409 f 1890, 74).

The continued spread of opium smoking eventually gave rise to a national movement in China designed to stop both the importation and production of opium. It is pleasing to record that the British Government fully reciprocated the Chinese views, and, notwithstanding the serious loss entailed to the revenue of India, entered into an agreement in 1907 whereby the export of opium to China ceased by 1913. The Japanese policy of the gradual suppression of opium-smoking was attended by considerable success up to the time of the Japanese invasion in 1945. In India, the Japanese deliberately encouraged the use of opium and morphine in those territories under their temporary control. On their part, the Government of India has consistently pursued its policy of prohibition. In 1926 they determined to reduce supplies of opium to the Far East by 10% annually, so that such exports were extinguished by 1935 (Dunnicliff, *Nature*, 1937, 140, 92). The export of opium to Malaya and its use for smoking has now been prohibited (1945).

Numerous attempts had been made during the seventeenth and eighteenth centuries to prepare active principles from opium, but no constituent of a definite nature was discovered until the opening of the nineteenth century. Derosne in 1803 noticed the separation of a crystalline body from the aqueous extract of opium (Ann. Chim. Phys., 1803, [ii], 257). The basic character of this was demonstrated by Robiquet (*ibid.*, 1817, [iii], 275) and by him it was designated as "codeine". Derosne had further observed that opium solutions are precipitated by alkalis, but thought that the precipitate was a compound that he had previously described what was probably the chief active constituent of opium, but his observations until ten years later (*ibid.* 1814, [i], 92, 225). Meanwhile, however, an apothecary of Eimbeck in Hanover, named Kopp, had pointed out that it was to be regarded as the first member of a new

class of substances, "the vegetable alkalis." With regard to Sertürner's claim it is to be noted that although narcotine had been isolated before morphine, its properties as an alkaloid were not ascertained until afterwards. During the same inquiry, in 1806, Sertürner also brought to light meconic acid, which is characteristic of opium.

*Raw Opium.*—Fresh opium is a brownish solid of somewhat plastic nature which becomes tough and occasionally brittle on keeping. The composition varies widely according to the source; a rough idea of the percentage composition of the usual commercial varieties is afforded by the following figures:

Moisture . . . . .	6-15
Ash . . . . .	4-8
Morphine . . . . .	8-17
Narcotine . . . . .	4-10
Other alkaloids . . . . .	1-7
Meconic acid . . . . .	3-7
Total extractive matter . . . . .	55-60

The ash consists mainly of calcium and magnesium sulphates. The extractive matter includes certain neutral bodies, of which the most important is meconine. Some 40-50% of opium is composed of indefinite gummy and resinous matter, together with pectin, albumin, and insoluble debris, the last consisting of fragments of capsules, wax, caoutchouc, calcium salts, etc. According to Hesse (Ber. 1889, 3, 637) the wax, of which 1-4% may be present, is a mixture of ceroyl palmitate and ceroyl cerotate. A trace of a sugar is also present. Poppy juice contains no starch or tannin, so that detection of these bodies in opium would indicate adulteration. Opium invariably contains ammonium salts. According to Thomson (Chemist and Druggist, 1920, [ii], 772) the average amount of ammonia present, whatever the variety, is about 0.2%.

The alkaloids are, of course, the most important constituents and are discussed later. According to Kerbosch (Arch. Pharm. 1910, 248, 536) poppy seeds are alkaloid-free and the various alkaloids make their first appearance in the green parts of the plant at widely different times. Narcotine was the first alkaloid which could be detected, and appeared 3 days after sprouting. Thereafter came codeine (after 30 days), morphine and papaverine (each after 36 days), and lastly thebaine. Narceine could be found only in the seed capsules and hence was probably not a transformation product of narcotine which occurred in all parts of the plant.

Opinions differing somewhat have been expressed as to the mode of combination of the alkaloids in opium (see Dott, Pharm. J. 1884, 14, [iii], 389; Dohme, Amer. J. Pharm. 1891, 73, 164; Annett and Bose, Mem. Dept. Agric. India, 1922, Chem. Series 7, 215). In general it may be stated that the sulphuric acid in opium is present wholly or mainly in inorganic combination, that the alkaloids are present wholly or mainly as meconates, and that the almost invariable acid reaction of opium is due to dissociation of the meconates of such weak bases as narcotine and papaverine. Biscaro (see Year-Book of Pharmacy, 1921, 118) records that he

lias met with two samples of opium possessing an alkaline reaction. This must certainly be regarded as abnormal.

### Production.

*Asia Minor.*—Opium is collected in Asia Minor for the most part by small peasant proprietors, the largest quantity being obtained from the western districts. The poppy grown is the variety *glabrum*, and the flowers are purplish, or sometimes white. The plant grows in both elevated and lower situations, and requires a moist soil and much attention and skill on the part of the cultivator. Details of the mode of preparing the soil and of the management of the crop are given by Maltass (Pharm. J. 1855, [i], 14,395) and Heffler (*ibid.* 1869, [ii], 10, 434). (See also *ibid.* 1883, [iii], 13, 918.) The crop is sometimes destroyed by early frosts, or the attacks of locusts. The seed is sown from November to March, and the flowering takes place from May to July. The capsules are ready for incision a few days after the petals have fallen, and are then about 1½ in. in diameter. According to Wallis (*ibid.* 1939, 143, 489), a special knife is used which ends in seven very small blades. These project only some 1.5 mm., so that too deep cuts cannot be made. The knife is drawn horizontally around the middle of the capsules, preferably in the afternoon. The following morning the partly hardened juice is scraped off, bulked, and transmitted to the Government factory at Istanbul. An important addition to the profits of the opium culture is the sale of poppy seed, from which the semi-drying oil is expressed and used for cooking, soap manufacture and other purposes (Maltass, Heffler, and Scherzer, *ibid.* 1881, [iii], 11, 835).

The Turkish Government monopoly opium is exported in sub-cylindrical masses about 9 cm. high and 15 cm. greatest diameter, weighing about 2 kg. Each case of opium contains 40 such blocks. This opium usually contains morphine 12-13 and codeine 0.8-1.0%. This is the variety preferably employed for the production of powder, tincture, and other medicinal preparations.

In 1939 the area given over to the cultivation of the opium poppy was 31,120 hectares, and the production of opium was 262,09 kg. (These figures, as well as corresponding figures for other countries, are taken from League of Nations Publication 1942, xi, 1.) Normally about 90% of the export is used for manufacturing purposes.

*Iran.*—The quantity of opium produced in Persia has for many years been steadily expanding and the quality has been improved. After 1870, Persian opium steadily displaced Indian opium in the Chinese market, and, quite apart from the considerable home consumption for smoking purposes, trade with central Asiatic territories appears to be extensive. In 1939 about 55% of the production, considered on the morphine content, was consumed by smoking. Opium for this purpose is obtained by cutting the capsules in the early morning and collecting the juice before sunrise to avoid discoloration. The juice is dried in sheds until the weight is reduced by about one-sixth and is then mixed

with 20-50% of Sarcocolla gums, grape juice, or other foreign material. The product is then gently boiled and the resulting paste is moulded into bricks or sticks which are wrapped in paper. The chief centre of cultivation is the area around Ispahan, but the Shiraz and Bushire districts also furnish supplies. In 1939 some 17,000 hectares furnished 672,000 kg., most of which consisted of opium prepared for smoking and hence poor in alkaloids.

The manufacturing grade of opium is wrapped in paper and packed into cases containing 80 rectangular blocks having an average weight of 1 kg. Persian opium, like Turkish, is a fairly light brown in colour, but has a less granular appearance on cutting. It is harder and more brittle than the Turkish variety, largely owing to its lesser moisture content. Extraction with water is apt to give a rather sticky marc and so this opium is not much employed for the preparation of opium galenicals. A sample examined by Jerriestad (Schweiz. Apoth.-Ztg. 1922, 60, 691) contained morphine 10.6%, meconic acid 4.5, codeine 3.23, narcotine 11.26, water 8%. Usually the morphine range is 12-13.5% and the codeine less than the figure given by Jerriestad, 2-25% being a reasonable average.

*India.*—Opium used to be one of the most important products of India. It is a Government monopoly in the British area, and is cultivated free in certain of the Native States, but must pay duty if sent out of these states. The two areas of cultivation are in the United Provinces and in the Malwa district of central India. In 1937 the areas under cultivation were 2,576 and 8,401 hectares, respectively, producing 47,381 and 191,410 kg. opium. About 75,000 kg. of the production of the Indian States was purchased by the central government. The total area under cultivation shows a continuous decline from about 769,000 acres in 1903 to 241,000 acres in 1912 and 26,700 acres in 1937. An historical review of the Indian cultivation is given by Zekert, Arch. Pharm. 2926, 264, 237.

Normally, practically all the product is retained, but in both world wars India has proved a valuable source of opium for manufacturing purposes. Large quantities of opium were formerly exported to Far Eastern countries. This trade has now vanished. In 1907 an agreement was entered into whereby the amount exported to China should be reduced annually, and in 1913 this trade was brought to an end (Bull. Imp. Inst. 1915, 507). Again, in 1926 it was agreed that supplies of Indian opium to other opium-smoking countries (except Burma) should be reduced annually by 10%. A considerable financial sacrifice was involved, for in 1926 the revenue from the sales was £750,000 and 10 years later it was nil (Dunncliff, Nature, 1937, 149, 92). Dunncliff points out that most of the opium retained in India is used as a common household remedy for various complaints.

The poppy grown in India is of two varieties, Bengal opium being mainly derived from white-flowered races, whilst Malwa opium is largely obtained from plants with purple flowers (Bull. Imp. Inst. 1915, 512). In addition to the dangers to which the crop is exposed in Asia



Minor, the Indian plant is liable to the attacks of a parasitical broom-rape, which attaches itself to the roots. In Bengal the seed is sown in Nowmber and the capsules are ready in February or March. They are then scarified vertically with a many-bladed instrument (Pharm. J., 1852, [i], 11, 207). The operation is repeated %-% times in the course of a few days, the exuded juice being scraped off each morning. In the Malwa area there is a practice of dipping the collecting knife in linseed oil occasionally to prevent the juice adhering. Owing to the heavy dews the Indian juice is much moister than the Turkish (*ibid.* 1852, [i], 11, 209). According to Iake (Agric. J. India, 1920, 15, 124; Pharm. J. 1922, 108, 192) the oldest poppy capsules, that is, the terminal ones, produce opium of greater morphine content than the lateral ones. Also, opium from the first incision, performed about a fortnight after petal-fall, may contain as much as 20% of morphine, an amount which falls off rapidly in the products of subsequent landings. In practice, latex from the different landings is mixed and made into a standard opium at Ghazipur.

Indian opium, as it reaches this country, is packed in casks holding about 160 lb. and containing roughly rectangular blocks of about 2 lb. weight. These are wrapped in paper, which is usually white. In colour the blocks are dark-brown, sometimes almost black, and are often somewhat brittle. In general the percentage of morphine is 9-10.5, and of codeine about 2-3. The amount of papaverine present is low, and sometimes it cannot be isolated at all (Van Italle and Kerbosch, Arch. Pharm. 1911, 248, 609). Rakshit gives some interesting analytical data regarding Indian opium (Analyst, 1921, w, 481; 1926, 51, 491; Ind. J. Pharm. 1932, 53).

*Yugo-Slavia*.—Cultivation of the opium poppy in southern Serbia began in 1865 from Turkish seeds. The production of opium in 1938 was 200 kg., all of which was employed in manufacturing processes. According to Wallis (Pharm. J. 1939, 143, 489) the capsules are incised by the use of a knife with a small curved and pointed blade, a circular equatorial-scratch being made. The raw opium is mixed at the Government factory in Belgrade, and is made into flat oblong cakes with rounded ends, 1.5-2.5 cm. thick, 1-2 cm. long, and 6-7\*5 cm. broad. These cakes weigh 160-225 g. and are packed with *Rumex fruticosa* in cases holding about 160 lb.

*Yugo-Slavia*.—Opium is a \*\*\*\*\* brittle variety, usually containing 15-17% of morphine and 2-3% of codeine. A sample examined by J. Wallis (Apoth.-Ztg. 1922, 60, 691) contained morphine 13.9, narcotine 4.7, codeine 2.1, meconic acid 6.9. The codeine, however, does not usually reach 2%. Further information is given by Brunetti, Bull. Sci. pharmacol. 1918, 25, 95, and by Vigoc, Chemist and Druggist, 1930, 118, 100.

*Egypt*.—Egyptian opium was never exported in very great quantity, and the cultivation of the poppy is now almost entirely confined to the Gharbiya Governorate, where it is still made. Production are still made. A 1936 Ae E Syrtian Government, with the aid of aeroplanes, detected about 800 acres devoted to poppy cultivation, hidden in

small patches among other crops (Pharm. J. 1937, 138, 629).

*Australia*.—There has been a small production of opium in Queensland, and especially in Victoria, since 1868. Successive sowings are made from May to July; the quality and yield of opium are average. For information regarding this variety of opium, see Pharm. J. 1871, [iii], 1, 272, 543, 972. The isolated position of Australia has fostered production during the Second World War, and a factory for the manufacture of opium alkaloids from the home-grown poppy came into production at the end of 1943 (Chemist and Druggist, 1943, ii, 316). The whole dried plant is employed as raw material, as in the Hungarian process.

*Russia*.—Since 1925 the cultivation of the opium poppy (mainly in Turkestan) has made great strides, and in 1937 85,280 kg. of opium were obtained from about 10,000 hectares. Much attention has been given to production of the most valuable strains. Nilov (Bull. Appl. Bot., Genetics and Plant-Breeding, 1934, Series A, 11, 21) examined various new sub-varieties, one of which gave an opium containing 28% of morphine. Vbrozhtzov and Troshchenko, (Compt. rend. Acad. Sci. U.R.S.S. 1935, 555) observed that samples of poppy latex analysed 2 hours after gathering showed about 20% of morphine, while, if allowed to stand until next day, the percentage dropped to about 12. They ascribed this diminution to atmospheric oxidation in presence of enzymes and found that the juice could be stabilised with potassium fluoride for several months. Their results, however, had been foreshadowed by Descharmes, who found that the morphine content diminished when the juice was slowly dried (J. Pharm. China. 1867, [iv], 6, 222).

*Bulgaria* has had a small production of about 7,000 kg. per year since the days of Turkish dominion. The type of opium produced resemble that of Yugo-Slavia; thus, of 119 samples examined by Nikolov (Rev. Inst. Agron. Res. Bulgaria, 1922, 2, 217), 62% contained 17-21% of morphine.

*Other Areas*.—Attempts have been made in most European countries, especially France, Germany, Denmark, and Italy, and also in North America, to cultivate the opium poppy. The results have shown that, provided the soil is suitable and the rainfall not excessive, it is possible in all these countries to produce opium the quality of which is at least equal to that from Asia Minor. The cost of collection has, however, invariably proved too high to allow effective competition with opium derived from the usual Eastern sources. For this reason the results obtained will not be discussed in detail.

There has been, however, in recent years an interesting development which appears likely to be permanent. Kopp in 1930 proposed that the whole poppy plant should be worked up for alkaloids without the intermediate formation and collection of opium. He anticipated that the yield of alkaloid from the fresh plants would be in the region of 0.03-0.036%, of which half to one-third would be morphine (Pharm. Weekblad, 1930, 67, 125). Kabay wrote to much the same effect (Pharm. Monatsh. 1930, 11, 73), and

eventually elaborated a process in which the dried disintegrated plant-parts were subjected to a preliminary extraction with sulphurous acid. This process received patent protection in Germany, the U.S.A. (U.S.P. 2009181, 1935), and Hungary (Hung.P. 109778, 1934). Somewhat similar processes have been patented by Hoffman-La Roche in the U.S.A. (U.S.P. 2132945, 1938) and in Switzerland. The method does not, however, appear to have been worked commercially except in Hungary, and since 1943 in Australia, and in Germany during the war (Kussner, Mercks Jahresber. 1940, -29). The actual yield of morphine from dry poppy-straw is 0.08-0.1%, and from the capsules up to 4 times this amount (Goris, Bull. Sci. pharmacol. 1938, 45, 265; Kussner, *l.e.*). Although these amounts are small the potential importance of the process lies in the fact that the raw material may be regarded as a by-product from the manufacture of edible poppy-seed oil (Goris, *l.c.*).

The opium poppy has in the past been an important product of China, but it is unlikely that it will again be grown except for the purpose of supplying the legitimate medicinal needs of the country. In the past it has often interfered with the growing of cereals and other food crops and contributed to food shortage. Strains considered suitable for smoking have been grown. These give opium poor in morphine, as shown by past analyses which record values of 2-6%. According to Chasovnikova (Biokhimiya, 1937, 2, 701) the Chinese poppy yields neither papaverine nor narcotine. The latter statement is not in agreement with those of previous analysts who have on occasion reported the presence of as much as 7% of narcotine. Arima and Iwakiri stated in 1938 that Manchurian opium is unusually rich in codeine and thebaine and may contain up to 4% of each. In 1937 the area of poppy cultivation was about five-sixths of that in Asia Minor and about 890,000 kg. of opium were produced, mostly for smoking.

Machiguchi (J. Pharm. Soc. Japan, 1926, 185) has given the most detailed description of Japanese opium. His analyses give the average percentage of 19 different alkaloids. The morphine content was usually 10-15%, codeine about 0-8%. Japan, including Korea, produced 52,139 kg. of opium in 1938. <>

The opium-smoking habit is widespread in Afghanistan, which was estimated in 1932 to be producing about 75,000 kg. of opium per year.

#### Physiological Action and Uses.

Opium is one of the most important remedies available for use in medicine. Its action is on the brain, dulling the sensation of pain, and producing sleep. In doses of a grain or less, a stage of slight excitement supervenes during which the individual can control his energies. In 1-2 grain doses the stage of excitement is short and is succeeded by deep sleep, after which there is more or less nausea and headache. If large doses of 3 grains or more are administered the excitement is very short and is followed by sleep which becomes more and more comatose until the patient cannot be aroused. If death takes place the respiration ceases first. Although opium is mainly used for the alleviation of pain, either

generally or locally, with or without the production of sleep, it has many special applications in the treatment of disease.

Opium is generally employed as a dehydrated powder, standardised by the addition of lactose or calcium phosphate to contain 10% of morphine; or as a tincture containing 1% of morphine; or as a 20% extract. Such preparations, with others less used, are official in most Pharmacopoeias. In recent years a preparation termed "Papatoretum" in the B.P.C. has obtained a certain vogue. It consists of a mixture of the hydrochlorides of the principle alkaloids of opium, and is standardised to contain 50% of morphine.

The action of opium in stimulating and then depressing gives rise to the desire to repeat the dose. In this way the habit of "opium eating" is contracted. The worst effects of opium are thus obtained. It deranges the nervous system, and impairs the intellectual and moral and finally also the physical powers, 'pope Quincey's description of his own experience is well known.

"A large quantity of opium is still used for smoking." The habit is believed to "have originated in Persia and spread over the Orient, prevailing to the greatest extent amongst the Chinese. The operation of opium-smoking has been described by Sampson (Pharm. J. 1881, [iii], '11, 22). The pipe has a flat bowl made of metal with a very small opening. A drop of the soft opium is taken on the point of a "dipper" and dexterously roasted in the flame of a little lamp until with constant burning it has the appearance of burnt worsted. Then, after the bowl of the pipe has been warmed, the drug, about the size of a hemp-seed, is placed about the opening in the bowl, the pipe taken in the mouth, and the opium ignited? The smoke is partly swallowed or inhaled and partly exhaled by the mouth and nose. The preparation for smoking occupies 5 to 10 minutes, but the actual smoking only about 30 seconds. (See also McCallum, *ibid.* 1881, [iii], 11, 229; 1882, 12, 446; Calvert, *ibid.* 1882, 12, 148.)

The physiological action of opium smoked in this way is clearly quite different from that obtained by taking it into the stomach, or from the effect produced by the equally deleterious practice of hypodermic injection of solutions of morphine or heroin. It is noteworthy that those opiums most highly prized for smoking, contain a small percentage of morphine. It would seem that although certainly detrimental to the working of both mind and body the habit of opium smoking is not quite so injurious as generally believed by Europeans. Opium in the East seems to perform the same function as alcohol in the West, and, as far as can be ascertained, with about the same bad effects when indulged in too freely (*cf.* Birdwood, *ibid.* 1882, [iii], 12, 500; Spence, *ibid.* 1883, 13, 226; McCallum *ibid.* 1884, 14, 27; James, *ibid.* 1888, 18, 280).

#### Commercial Manufacture of Opium Alkaloids.

The Gregory method for the manufacture of morphine was adumbrated by Robertson (J. Pharm. 1833, [ij], 19, 108). According to the Robertson—Gregory method, opium was extracted

with lukewarm water and the liquid was mixed with excess of chalk and filtered. Slight excess of calcium chloride was added to the syrupy filtrate which was then diluted with water. This precipitated the sludge of resins, calcium meconate, etc., which was filtered off. On concentrating the liquid, or on salting out with hydrochloric acid from a solution of sp. gr. 1.020, "Gregory's salt" crystallised out (Gregory, *Annalen*, 1833, 7, 261). This was regarded as morphine hydrochloride, which indeed it was essentially. However, Hobiquet (*ibid.* 1833, 5, 106) had shown that "Gregory's salt" on precipitation with ammonia did not yield the expected amount of morphine. On evaporating the ammoniacal mother-liquid and adding potassium hydroxide he obtained a new-alkaloid, codeine, which had not been known down to any great extent by the ammonia. The Gregory method was, therefore, continued in the direction indicated, and was later extended to include the production of other alkaloids (Anderson, *ibid.* 1803, 86, 179). According to Anderson, the black mother-liquids from the separation of morphine and codeine were diluted and ammoniac was added. This retained narcotine in solution and precipitated thebaine. From an alcoholic extract of the precipitate narcotine separated on cooling. Alcohol was evaporated from the mother-liquid and the residue was treated with dilute acetic acid and basic lead acetate. This removed narcotine and resins, and after getting rid of dissolved lead with sulphuric acid thebaine could be thrown down by ammonia. For narcotine the original ammoniacal liquid was subjected to a lead treatment, and after removal of lead and neutralisation with ammonia was gently evaporated to the crystallisation point. It was later found that crude narcotine contained papaverine, which could be separated out as an acid oxalate, owing to its more sparing solubility.

Of those more modern processes for utilising opium which have been published reference may be made to the following.

Kanewskaia (J. pr. Chem. 1924, [ii], 108, 247) extracted opium with 4 parts of water and concentrated the extract to the weight of opium taken. An equal volume of alcohol was added to the syrup and then excess ammonia. 96% of the contained morphine was precipitated after 4 hours, together with some narcotine, which was dissolved out with benzene. The ammoniacal mother-liquid was also extracted with benzene. From this, dilute acetic acid removed codeine and thebaine but not the weak base papaverine. The codeine and thebaine were separated by addition of ammonia, which threw down thebaine, and the codeine was then extracted with chloroform.

According to Ishikawa and Maruta (Pull. Hyg. Res. Inst. Jap. 1929, 85, 19) opium is leached with water, treated with a large excess of lime and filtered. Morphine and codeine may be obtained from the filtrate in the usual manner, thebaine is extracted with benzene; which is then distilled off. The residue consists chiefly of narcotine, papaverine, and thebaine. Addition of a small amount of acetic acid to this residue does not dissolve narcotine, which may be filtered off. The mother-liquid is neutralised

with sodium hydroxide, thus precipitating papaverine, which may be purified as oxalate. Excess alkali added to the neutral filtrate precipitates thebaine, purified as tartrate.

For other processes, devised by Bume and Busse (*Khim. Farm. Prom.* 1937, 127) and Chemnitius (*Pharm. Zentr.* 1929, 70, 101) reference should be made to the original papers or the appropriate abstracts. Mention may also be made of a scheme proposed by Dott, which is to be found in Allen's "Commercial Organic Analysis," 5th ed., Churchill, 1929, Vol. VII, p. 671.\* Plugge (*Arch. Pharm.* 1887, 24, 994) elaborated a method for separating the six principal alkaloids from opium, which however could hardly be used as a basis for manufacture. An interesting account of a modern German process is given in *Pharm. J.* 1945, 155, 220. This is based on the description given in J. Schwyzer's "Fabrikation der Alkaloide," Springer, Berlin, 1927.

### Extraction of Minor Alkaloids from Opium.

Contributions to the knowledge of the systematic extraction of minor alkaloids from opium have been made by Plugge (*Arch. Pharm.* 1886, 224, 993) and Merck (*Annalen*, 1836-39, 18, 79; 21, 202; 24, 46). Hesse, however, has been the most indefatigable worker in this field (*see ibid.* 1370, 153, 47; 1894, 282, 209; *Annalen Suppl.* 1872, 8, 262, 272). The following description of Hesse's methods is due to Kauder (*Arch. Pharm.* 1890, 228, 419).

An aqueous extract of opium is treated with calcium chloride and the precipitated meconate is filtered off. On concentration, the hydrochlorides of *morphine*, *pseudomorphine*, and *codeine* crystallise out in turn. The residual liquids are diluted and the remaining alkaloids precipitated by ammonia, the precipitate being dissolved in acetic acid, filtered, shaken with ether to remove certain non-alkaloidal bodies, and made alkaline with excess sodium hydroxide. By this procedure there is obtained a precipitate (A) and a filtrate (B) containing the phenolic alkaloids together with some of the cryptopine.

The precipitate (A) is dissolved in the least amount of warm dilute alcohol containing a slight excess of acetic acid. Dilution with 3 vols. of boiling water hydrolyses the acetates of the weak bases *narcotine* and *papaverine* and throws down the free alkaloids, from which filtrate (C) is obtained. The papaverine and narcotine are separated by converting to acid oxalates and crystallising out the salt of the former base.

Filtrate (B) is concentrated to remove alcohol. On adding tartaric acid solution thebaine is precipitated as acid tartrate. The filtrate from the thebaine is neutralised with ammonia and 3% solid sodium bicarbonate is dissolved in it. After standing for a week a small amount of dark-coloured tar is removed. The clear filtrate is treated with ammonia and the solid obtained is extracted with hot benzene, giving a solution (D) and a residue (E). When (D) is shaken with a solution of sodium bicarbonate a precipitate is obtained which is found to consist essentially of *laudanosine*, and on filtering the benzene and passing in dry hydrogen chloride, crystals of

*hydrocotarnine* hydrochloride are obtained. The residue (E) is mainly composed of *ofprotopine* and *cryptopine*. These are separated by conversion to hydrochlorides and crystallisation from water, in which protopine hydrochloride is only slightly soluble.

The alkaline filtrate (B) is neutralised with hydrochloric acid, and after adding excess ammonia the liquid is extracted with ether. The ethereal liquid is shaken out with acetic acid; the acid solution is neutralised with ammonia, and after 24 hours *lanthopine* has separated. On adding more ammonia to the filtrate a precipitate is obtained which is dissolved in hot dilute alcohol. On cooling, *laudanine* and *laudanine* with some *cryptopine* are obtained. The remaining alcoholic solution is evaporated and gives a residue from which *codamine* can be isolated as hy.riodide.

#### Assay of Morphine in Opium.

The market value of opium depends on its content of morphine, the alkaloid from which most of the medicinal value of the drug derives. For this reason the assay of opium for morphine has attracted much attention. The first paper dealing with this assay appears to be one by Guillermond (J. Pharm. Ghim. 1828, 14, 436). Since then the bibliography has become so voluminous that no attempt can be made here to discuss it in detail.

Official methods of assay generally make use of the solubility of morphine in lime-water in order to separate this alkaloid from the others present with it. Typical of such methods is that of the British Pharmacopoeia (1932), which gives the following directions: 8 g. of opium are triturated with 10 ml. of water in a mortar to give a uniform mixture, which is then thoroughly incorporated with 2 g. of calcium hydroxide and a further 20 ml. of water. The contents of the mortar are transferred to a tared flask using sufficient water to produce 90 g. The flask is shaken occasionally for half an hour and the contents are then filtered. 52 ml. of filtrate are collected, representing 5 g. of opium. To this filtrate, contained in a small flask, are added 5 ml. of alcohol, 25 ml. of ether, and 2 g. of ammonium chloride. The whole is shaken for 5 minutes, and then occasionally for half an hour. Next morning the ethereal layer is decanted through a funnel fitted with a plug of cotton-wool. The flask is rinsed out with 10 ml. of ether, followed by 5 ml., both quantities being passed through the wool. Finally, the aqueous liquid is poured through the filter and the flask rinsed well with a saturated solution of morphine in water. According to the official directions the morphine left on the filter is now washed back into the flask and dissolved in 20 ml. of 0.1 N. sulphuric acid. The excess of acid is titrated with 0.1 N. sodium hydroxide, using Methyl Red as indicator. To the amount shown by the titration 0.052 g. is added to compensate for loss of morphine due to its solubility. This process with suitable modifications serves to determine morphine in all simple extracts and tinctures.

In the U.S.P. 1942, 6 g. of opium are thoroughly extracted with water. The extract is partially evaporated, triturated with lime and filtered.

Morphine is precipitated from the filtrate by adding ammonium chloride and shaking. Alcohol and ether are added as in the B.P. The morphine is filtered off and washed and the crystals dissolved from the filter by the repeated passage of small quantities of boiling methanol. After dilution, most of the methanol is evaporated off and the morphine is titrated with 0.1 N. acid. There is no solubility correction.

It has long been recognised that the excellent results obtained by methods such as that of the B.P. depend for their reproducibility upon a faithful adherence to the prescribed conditions, whereupon a somewhat fortuitous cancelling-out of various errors occurs.

A criticism that has often been made is that phenolic alkaloids other than morphine are dissolved as calcium salts and subsequently precipitated by ammonia. About 2% of the crude morphine obtained consists of such alkaloids (Bakshit, Analyst, 1931, 56, 711). Again, codeine is soluble in aqueous liquids and passes through to the final stage with calcium morphinate. When ammonium chloride is added some of the codeine appears to be precipitated with morphine in the form of a mixed crystal from which it is not easily extracted, by the ether used in the assay. Bakshit puts the additional weight thus conferred at about 3%, and this is also taken by Rosin and Williams (J. Amer. Pharm. Assoc. 1935, 24, 1053). On the other hand Bakshit considers that the presence of codeine in the final liquid hinders the complete separation of morphine. Another factor which tends to reduce the alkaloid titrated is the almost certain absorption of some morphine on the lime-containing marc from which the solution of calcium morphinate is filtered (Bosin). This by no means exhausts the possible sources of error in the assay. Two more of these may be mentioned here. In the first place it is evident that discrepancies may result from the varying amounts of water and extractive contained in different samples of opium. Secondly, calcium ammonium meconate (about 2%; Bosin) is precipitated with the morphine and is titrated as morphine unless the latter is dissolved away by methyl alcohol or other solvent.

Recognition of the errors inherent in the lime method caused the League of Nations to institute research directed towards the provision of an international method of assay. As a result a process was recommended which in its essentials was that of the B.P. 1932 (Bull. Health Org. L.N. 1938, 7, 429; see Year-Book of Pharmacy, 1938, 767). The principal differences consist in the provision of corrections for the moisture in the opium and the extractive matter in the lime filtrate. As in the U.S.P. process, the crude morphine obtained is purified by dissolving in warm methyl alcohol and filtering. Certain difficulties have thus been removed, but the method has not escaped criticism.

Of those processes which involve determination of morphine as a derivative mention will only be made of that due to Mannich (Arch. Pharm. 1935, 273, 97). Mannich makes a lime extract of the opium, frees the filtrate from calcium by adding oxalate, and precipitates the morphine as the 2:4-dinitrophenyl ether. The

results are somewhat high, mainly owing to coprecipitation of other ethers, and are improved by shaking out the lime filtrate with ether-chloroform before the final step (Winterfeld *et al.*, *ibid.* 1937, 275, 445).

#### Opium Legislation.

Legally considered, morphine is a "dangerous drug." This means, not an unusually poisonous substance, but one the uncontrolled use of which leads to addiction. Such compounds have been subject to international control since the close of the First World War. When the peace conference met at Paris, ratification of the opium convention signed at the Hague in 1912 was made one of the terms of the Treaty of Versailles. The peace conference inserted in the Covenant\* of the League of Nations a provision which entrusted the League with the supervision and execution of existing conventions in regard to dangerous drugs. This work is to be carried on by U.N.O. So far as Great Britain is concerned the various agreements reached at conferences of the League have crystallised in the form of Regulations dating 1920, 37. The broad effect of these is that the import, export, trade in, and manufacture of opium, or its medicinal preparations, or of morphine and its derivatives is strictly controlled and "may be carried on only by licence. Power has been taken to bring under control any new products derived from opium alkaloids which are capable of producing addiction or which may be converted into drugs of this nature..

#### OPIUM ALKALOIDS.

Opium occupies a unique position in respect of the number of alkaloids which it contains. These are dealt with in detail below and fall naturally into five groups: (a) The morphine group, which contains the important alkaloids morphine, codeine, and thebaine; (b) the benzylisoquinoline group, the most important members of which are papaverine and narcotine; (c) dihydroquinoline alkaloids such as cryptopine; (d) tetrahydroquinoline alkaloids, represented off by hydrocotarnine; and (e) alkaloids of unknown constitution. >

##### (a) MORPHINE GROUP.

Morphine,  $C_{17}H_{19}O_3N$ .—This, the first vegetable alkaloid known, was isolated by Settemer in 1805 (Trommsdorff's *Journal der Pharmazie*, 13, 234; *see also* *Ann. Chim. Phys.* 1817, [ii], & 21). It apparently occurs only in the opium poppy, although various investigators have reported the presence of traces of morphine in other papaveraceous plants, later research has invariably disproved the claim. The first analysis was made by Liebig, but the correct elementary formula was first published by Laurent (*ibid.* 1847, [iii], 19, 359).

*Properties.*—It is generally met with as the anhydrous form and is rendered anhydrous only slowly at 100°, more rapidly at 110°. Morphine shows a tendency to sublimation at about 200° (Blyth, *J.C.S.* 1878, 33, 313), but does not melt until 247-248°, with decomposition (Kempf, *pr. Chem.*, 1908, [ii], 78, 201).

Only slightly soluble in water: 1 in 5,000 at 20°, 1 in 500 at 100°. The solubility in absolute alcohol is 1 in 90 at 10° and 1 in 11.6 at the b.p. Less soluble in amyl alcohol; 1 in 400 at 10°, 1 in 90 at the b.p. Very slightly soluble in ether, benzene, chloroform, or light petroleum (Florio, *Gazzetta*, 1883, 13, 496; Prescott, *Pharm. J.* 1875, [iii], 6, 404; Muller, *Apoth.-Ztg.* 1903, 18, 257). Fabre (*Bull. Soc. Pharm. Bordeaux*, 1924, 62, 68) gives the solubility in 100 g. benzyl alcohol as 50 g. (boiling) and 21.5 g. (20°) and in nitrobenzene as 0.51 in 100 at 20° and 10.5 in 100 at the b.p. Morphine is readily soluble in sodium hydroxide solution, but the calcium salt has a more restricted solubility of about 1% at room temperature. Dilute ammonia does not dissolve morphine to any important extent. In methyl alcohol (c=2-3),  $[\alpha]_D^{20} -130.9^\circ$  (Schryver and Lees, *J.C.S.* 1900, 77, 1(4)). For the sodium salt  $[\alpha]_D^{20} -70.2^\circ$  (Hesse, *Annalen*, 1875, 176, 190). Tykociner (*Rec. trav. chim.* 1882, 1, 144) examined the optical rotations of a number of salts. Gompel and Henri (*Compt. rend.* 1913, 157, 1422) compared the ultra-violet absorption spectrum of morphine with those of codeine and phenanthrene.

Morphine is a moderately strong base, the salts of which are neutral to litmus and, in general, easy to crystallise. Methyl morphine is the best indicator; for titrating the free base. The principal salts used in medicine are the hydrochloride, sulphate, tartrate, and acetate.  $P.HCl, 3H_2O$  forms silky needles soluble 1 in 24 in water at 15°, and 1 in 0.5 parts at 100°. Double salts are formed with mercuric and platinum chlorides.  $B_2.H_2SO_4, 5H_2O$  shows a solubility very similar to that of the hydrochloride. The acetate contains  $3H_2O$ , and is very soluble (1 in 2.25 in water at 25°). It loses acetic acid on standing in the air and becomes coloured. The tartrate also contains  $3H_2O$ , and forms efflorescent needles soluble in 11 parts water, and the acid tartrate contains  $2H_2O$  and is much less soluble than the neutral salt. Claims have been made at times that salts other than those mentioned above are more suitable for medicinal use. Thus, Regnier (*Compt. rend. Soc. Biol.* 1936, 122, 789) states that the phenylpropionate is considerably less toxic than the hydrochloride when injected subcutaneously. With this may be compared the observation of Eastland (*Nature*, 1944, 154, 829) that for a given dose of morphine, the period of narcosis is extended if the base is administered as mucate.

The most important alkyl derivative of morphine is the methyl ether, codeine, which is discussed later. Besides this, ethylmorphine (m.p. of hydrochloride 117-123°) or "Dionine," and benzylmorphine, or "Peronine" are employed in medicine to a small extent. Diacetylmorphine (m.p. 169-172°) was known originally as "heroin." The hydrochloride melts at about 230° and is "official" in the British Pharmacopoeia under the designation "diamorphine hydrochloride." Solutions of diamorphine salts hydrolyse slowly on standing.

Normally alkylation or acylation leads to substitution in position 3 or to disubstituted

compounds; 6-acylmorphines, which contain a phenolic hydroxyl, have only been obtained recently. Mannich (Arch. Pharm. 1939, 277, 128) benzoylated 3-benzylmorphine, obtaining the 3-benzyl-6-benzoyl compound, which with cold hydrochloric acid gave the 6-benzoyl derivative. Heterocodeine, which is the 6-methyl ether, had to be prepared in a similar roundabout way (Mannich, *ibid.* 1916, 254, 349)..

When morphine is heated with 25% hydrochloric acid in a sealed tube at 140° it loses the elements of water and apomorphine, C<sub>17</sub>H<sub>17</sub>O<sub>2</sub>N, is produced. This may be isolated by adding sodium bicarbonate in excess to the acid liquid and shaking with ether. By extracting the ether layer with hydrochloric acid the sparingly soluble hydrochloride may be obtained. A rather more convenient preparation is described by Oparina, Karasina, and Smirnov (Khim. Farm. Prom. 1934, No. 5, 18), who passed hydrogen chloride through a hot solution of morphine in phosphoric acid. The properties of apomorphine indicate that it still contains the original phenolic hydroxyl together with a second due to fission of the oxygen bridge in morphine. A methylated pyridine ring is attached to the phenanthrene nucleus in positions 8 and 9. Solutions of apomorphine are unstable when exposed to air and absorb oxygen, especially in presence of alkali, with production of a green, and afterwards a red colour. The physiological action of apomorphine differs entirely from that of the parent compound, since it produces no narcotic effect but acts as a powerful emetic (*see* Matthiessen and Wright, Proc. Roy. Soc. 1869, 17/455; Marmel Z. anal. Chem. 1885, 24, 643; Pschorr *et al.*, Ber. 1907, 35, 4377).

Morphinone, the ketone corresponding to morphine, is not known, but dihydromorphinone ("Dilaudide"), which has been introduced into the latest U.S. Pharmacopoeia, is obtained by heating a morphine solution in presence of a large amount of a platinum-metal catalyst (Knoll, G.P. 365683; 380919). Dihydromorphine, m.p. 157°, the hydrochloride of which is known as "Paramorfan" is readily formed by mild hydrogenation (Skita, Ber. 1911, 44, 2862). It is much more stable than morphine and its dimethyl ether is identical with tetrahydrothebaine. Morphine couples normally, with diazotised aniline to give an azo-compound which is reduced to 2-aminomorphine by stannous chloride (Wieland, *I.e.*).

*Isomers of Morphine and Codeine.*—Phosphorus halides or thionyl chloride act on morphine or codeine to give a-chloro-morphide or -codeide, in which the alcoholic hydroxyl is replaced by chlorine. When these chloro-compounds are treated with concentrated hydrochloric acid isomeric compounds are formed (Ach and Steinbock, *ibid.* 1907, 40, 4281). If they are hydrolysed with boiling water or dilute acetic acid a mixture of isomeric morphines or codeines is produced. In a-tfomorphine the hydroxyl group is attached to C<sub>6</sub> as in morphine, while in the  $\beta$ -iso- and  $\gamma$ -iso- bodies the attachment is to C<sub>8</sub> with a consequent shift in the double bond. The relationships developed may be illustrated as follows:

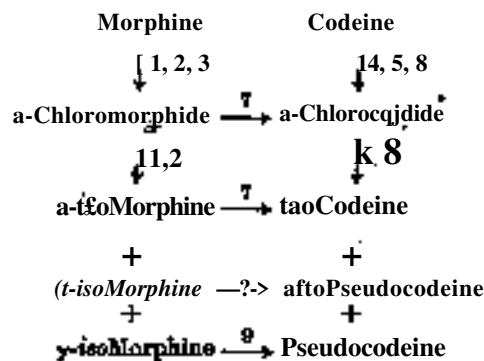

1. Schryver and Lees, J.C.S. 1900, 77, 1024.
- #. Oppf. Ber. 1908, 41, 075.
3. Wieland, Annalen, 1911; 382, 306.
4. Vongerichten, *ibid.* 1881, 210, 105.
5. Freund, J. pr. Chem. 1921, [ii], 101, 1.
6. Small, J. Amer. Chem. Soc. 1931, 52, 2214.
7. Lees, J.G.S. 1907, 91, 1408.
8. Speyer and Ki-auss, Annalen, 1923, 432, 233.
9. Knorr, Ber. 1907, 40/3844.

A pharmacological comparison of the codeine isomers has been carried out by N. B. Eddy (J. Pharmacol. 1932, 46, 361) in which the general conclusion arrived at was that *iso*- and *pseudo*-codeines possess certain advantages over codeine. Dihydrocodeine was even more advantageous (*ibid.* 1934, 51, 35).

*Constitution.*—It is convenient to discuss the structure of morphine and codeine together as they are so closely related. To avoid confusion the numbering adopted in the following discussion will be that of the attached Gulland-Bobinson formula (I) for morphine (Mem. Manchester Phil. Soc. 1925, 69, 79), which is now accepted generally.

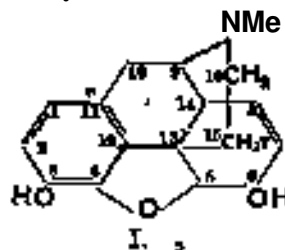

Morphine and codeine are tertiary bases which combine with 1 mol. proportion of alkyl halide. A dibenzoyl and a diacetyl derivative of morphine have been prepared, whence it may be inferred that the alkaloid contains two hydroxyl groups (Wright *et al.*, J.C.S. 1874, 27, 1031; 1875, 28, 15; 1880, 37, 610). One hydroxyl has phenolic properties; thus morphine dissolves in alkalis forming metallic derivatives in which 1 atom of hydrogen is replaced by the metal (Chastaing, Compt. rend. 1882, 94, 44J). Methylation of morphine gives codeine (Grimaux, *ibid.* 1881, 92, 1140, 1228; Hesse, Annalen, 1883, 222, 203). This is non-phenolic, but behaves like a secondary alcohol in being capable of oxidation to a ketone, *codeinone* (Ach and Knorr, Ber. 1903, 36, 3067). Thus morphine and codeine may be written

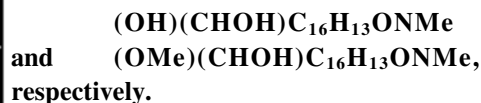

The third oxygen atom in both substances is inert, and the inference that it is present as an ether linkage is confirmed by certain degradations\* which involve the elimination of nitrogen and the eventual production\* of phenanthrene derivatives. Thus, codeine methiodide gives the normal quaternary ammonium hydroxide with silver oxide or sodium hydroxide, and this on warming loses water, forming *methylmorphimethine*,  $(\text{OMe})(\text{CHOH})\text{C}_{15}\text{H}_{12}\text{ONMe}$ , in which the nitrogen is at the end of a side-chain (Grimaux, Ann. Chim. Phys. 1882, [v], 27, 273; Heuss, l.c.). If the Hofmann degradation is carried a step further the nitrogen is eliminated as trimethylamine, as would be expected. In addition, the tendency of the system to become completely aromatic is sufficiently great to cause extrusion of the remainder of the side-chain as ethylene. The resulting\* non-nitrogenous product is *methylmorphenol* (II) (Knorr, Ber. 1889, 22, 181; Vongerichte-, *ibid.* 1896, 29, 65).

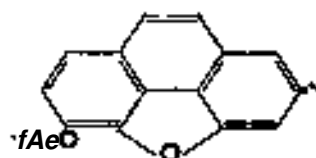

II.

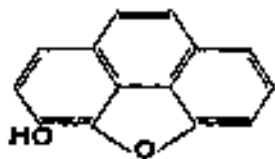

III.

The demethylated product *morpkenol* (III) contains one phenolic hydroxyl and an inert oxygen atom which is etheric because on reduction with sodium and alcohol the diphenolic compound *morpfol* (IV) is\* obtained (Vongerichten, *ibid.* 1898, 31, 3198). Pschorr's synthetic 3:4-dimethoxyphenanthrene (*ibid.* 1900, 33, 1810) proved to be identical with morphol dimethyl ether (Vongerichten, *ibid.*, p. 1824). Hence morphol is 3:4-dihydroxyphenanthrene.

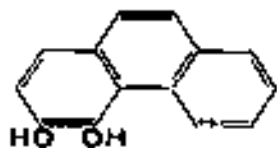

IV.

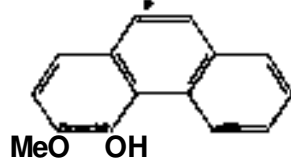

V.

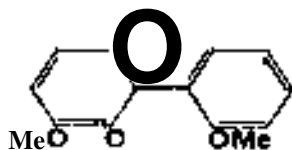

VI.

If methylmorphimethine is boiled with acetic anhydride, it is partly decomposed into ethanol-dimethylamine,  $\text{CH}_2(\text{OH})\text{CH}_2\text{NMe}_2$ , and a *methylmorphol* (Knorr, Ber. 1889, 22, 1113; Vongerichten, *ibid.* 1897, 30, 2439). Pachorr synthesised 3-hydroxy-4-methoxyphenanthrene (*ibid.* 1900, 33, 1810) which proved to be not the same as the above methylmorphol, which, therefore, had to be formulated as 3-methoxy-4-hydroxyphenanthrene (V). It followed that the ether link existing in methylmorphenol had one point of attachment at position 4. The other end of this oxygen bridge was shown to be located at 5 by fusing morphenol with potassium hydroxide. This gave a trihydroxyphenanthrene (Vongerichten, *ibid.* 1906, 89, 17, 18), the trimethyl ether of which was identical with synthetic 3:4:5-trimethoxyphenanthrene (VI) (Pschorr, Annalen, 1912, 891, 40).

As has already been mentioned, the secondary alcoholic group in codeine may be oxidised to keto, giving codeinone. With boiling acetic anhydride this yields ethanolmethylamine and 3-methoxy-4:6-dihydroxyphenanthrene (Knorr, Ber. 1903, 36, 3074) (VII). This shows that the alcoholic grouping in codeine and morphine is present at position 6.

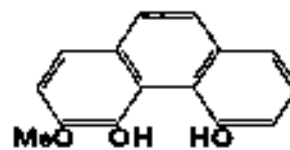

VII.

The evidence so far adduced might be confirmed and strengthened in many ways. It is, however, sufficient to show that the morphine molecule may be regarded as built up from the following complexes, which together contain four hydrogen atoms less than morphine.

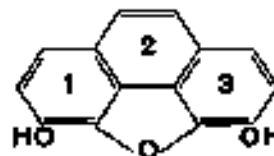

and

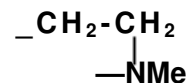

Ring 3, which contains a secondary alcoholic group, must be partially reduced; and the work of Knorr (*ibid.* 1906, 39, 1414) and Pschorr (*ibid.*, p. 3137) shows that ring 2 must be in a similar condition. The way in which the four additional hydrogen atoms are distributed between the reduced nuclei depends upon the points of attachment of the nitrogen complex. This is a matter which has aroused much controversy and the bringing forward of many formulae (see, e.g., Knorr, *ibid.* 1889, 22, 1131; 1899, 32, 742; 1903, 36, 3074; Pschorr, *ibid.* 1902, 35, 4377; Knorr and Horlein, *ibid.* 1907, 40, 2042; Von Braun, *ibid.* 1914, 47, 2312; Freund, *ibid.* 1916, 49, 1287; Faltis, Arch. Pharm. 1917, 255, 86).

Gulland and Robinson (J.C.S. 1923, 123, 985, 998) reviewed the available evidence for the structure of morphine and codeine and stated their preference for positions 9 and 13 as the points of attachment for the nitrogen ring. In this formula the carbon atom at 15 was linked to C<sub>13</sub>, C<sub>6</sub>, and C<sub>8</sub> and there was no provision for an ethylenic bond in nucleus 3. Experiments carried out on hydroxycodone and its dihydro-derivative caused Gulland and Robinson to revise their formula. They arrived at the conclusion that the former substance did not contain the grouping —CO—CH<sub>a</sub>— but that the latter substance did. This was most easily explained by regarding the carbon atom at 15 as secondary instead of tertiary. This postulate necessitated the representation of a double bond in nucleus 3; the most likely position being C<sub>7</sub>—C<sub>8</sub>. The revised formula is more in accord with such facts as the ready hydrogenation of morphine and codeine to dihydro-compounds under mild conditions (e.g., Skita, Ber. 1911, 44, 2862), and the addition of two hydroxyl groups to codeine with dilute permanganate (Robinson and Cahn, J.C.S. 1926, 128, 908).

**Codeine.**—*Preparation.*—(For preparation from opium, see p. 103d.) Most of the codeine manufactured is obtained by methylating the phenolic hydroxyl in morphine. Many processes have been employed for this purpose, but the yields are often rather low owing to the side-reactions resulting from the presence of the tertiary nitrogen atom and the alcoholic hydroxyl. The most successful method published would appear to be that described by Boehringer (G.P. 247180, 1909), which employs phenyltrimethylammonium hydroxide as the methylating agent. Rodinov (Bull. Soc. chim. 1926, [iv], 39, 305) describes the preparation and use of this compound (see also Pharm. J. 1945, 155, 220).

*Properties.*—Codeine is usually met with as the monohydrate, but may be obtained anhydrous by drying at 100°, or by crystallising from dry ether or benzene. M.p. 155°, [α]<sub>D</sub> -135.9° in 97% alcohol and -111.5° in chloroform (Hesse, Annalen, 1875, 176, 189). Codeine is sparingly soluble in water (1 in 120 at 20°; 1 in 31 at 100°) and in light petroleum, rather more soluble in ether, moderately soluble in benzene, readily soluble in acetone, alcohol, and chloroform (see Rakshit, Analyst, 1921, 46, 481).

Codeine is more strongly basic than morphine. The neutral point of the hydrochloride is at pH 4.93, as against 4.68 for the morphine salt (Rasmussen, Z. Elektrochem. 1925, 31, 189). The salts in general use are the *hydrochloride*, the *sulphate*, and the *phosphate*. B, HCl, 2H<sub>2</sub>O, m.p. 264° (anhyd), short needles soluble in 28.5 parts of water at 15°. B<sub>2</sub>, H<sub>2</sub>SO<sub>4</sub>, 5H<sub>2</sub>O, m.p. 278°, readily loses 2H<sub>2</sub>O in air, is completely dehydrated at 100°, but regains 3H<sub>2</sub>O on re-exposure; \* soluble in 40 parts of water at 15°; very sparingly soluble in alcohol (about 1 in 1,100). The phosphate, B, H<sub>3</sub>PO<sub>4</sub>, may occur with varying proportions of water, but that of the British Pharmacopoeia contains 1H<sub>2</sub>O, soluble in 3.5 parts of water at 15°. The *salicylate* is a difficultly soluble salt. *Picrate*, m.p. 197°.

*Reactions.*—Like morphine, codeine gives by

catalytic hydrogenation a dihydro-compound, m.p. 112° (anhyd), by addition of hydrogen in the 7:8 position (see, e.g., Skita, Ber. 1911, 44, 2862). This compound is termed "*Paracodin*" commercially. Codeine is much more stable to oxidising agents than is morphine. With hot chromic-acid mixture the ketone codeinone is obtained (Ach and Knorr, *ibid.* 1903, 36, 3P67), while in the cold 9-hydroxycodone is the main product (*idem, ibid.*). Very dilute permanganate effects addition of two hydroxyl groups to the double bond (Cahn and Robinson, J.C.S. 1926, 128, 908).

As with morphine, 30% hydrogen peroxide gives rise to a N-oxide (Freund and Speyer, J. pr. Chem. 1916, [ii], 94, 135). This, with potassium chromate, produces norcodeine with loss of formaldehyde (Diels and Fischer, Ber. 1916, 49, 1721). The action of allyl bromide on this demethylated codeine gives N-allylnorcodeine, which is said to have a pharmacological action opposite to that of morphine (Pohl, Z. exp. Path. Therap. 1915, 17, 370).

Nitric acid in glacial acetic acid gives the 2-nitro-derivative (Knorr, Ber. 1909, 42, 3503). Acetylation with acetic anhydride proceeds normally to give *acetylcodeine*, m.p. 133°.

If codeine hydrochloride or hydrobromide is dissolved in 30% formic acid and 30% hydrogen peroxide is added, a monohalogen-derivative which is still alcoholic is obtained (Speyer and Rosenfeld, *ibid.* 1925, 58 [B], 1110). On the other hand, with the aid of phosphorus halides, the alcoholic group in codeine may be readily replaced by halogen, giving chloro- or bromcodeine (see morphine section, p. 1066).

*Uses.*—The phosphate is the compound most used in medicine. It finds considerable employment as a constituent of various compound analgesic tablets and cough preparations.

*Detection.*—Codeine is distinguished from morphine by not giving the colour reaction with ferric chloride, and by producing with nitric acid a yellow and not a red colour. Concentrated sulphuric acid does not colour codeine except after long standing, but if a trace of nitril acid or ferric chloride is added to the mixture it becomes blue. Wagenaar (Pharm. Weekblad, 1927, 64, 671) describes numerous microchemical tests for codeine.

Thebaine, C<sub>19</sub>H<sub>21</sub>O<sub>8</sub>N, occurs in opium to the extent of 0.1-1%. It was discovered by Pelletier (Compt. rend. 1835, 1, Id), and the correct composition was first determined by Anderson (J. pr. Chem. 1852, [i], 57, 358), who described its isolation from opium (Annalen, 1853, 86, 179; see also Hesse, *ibid.* 1870, [i], 153, 47). Hesse treated the mother-liquors from which morphine and codeine had been separated with excess alkali. Dilute acetic acid dissolved out from the precipitate thus obtained only the strong bases, and on adding excess tartaric acid to the solution of acetates sparingly soluble thebaine acid tartrate crystallised out.

*Properity.*—Thebaine crystallises from alcohol in leaflets, m.p. 193°, [α]<sub>D</sub> -218.6° in 97% alcohol (Hesse, *ibid.* 1875, 176, 189). Practically insoluble in water or alkalis but dissolves in 140 parts of ether, 59 parts of amyl alcohol, 19 parts of benzene, or 18 parts of chloroform. -



It is a strong monoacidic base and gives hydrochloride,  $B.HCl.H_2O$ , soluble in 15 parts of cold water. The sodium tartrate, which also contains 1 mol. of water of crystallisation, is soluble in 130 parts of water and the salicylate is even less soluble. The alkaloid is poisonous and exerts a tetanising action which is, however, less than that of strychnine. With concentrated sulphuric acid a bright red colour is produced.

**Constitution and Reactions.**—Howard and Roser (Ber. 1884, 17, 627; 1886, 19, 1596) showed that the base contained two methoxyl groups and a tertiary nitrogen. They expressed its relationship to morphine and codeine as follows:

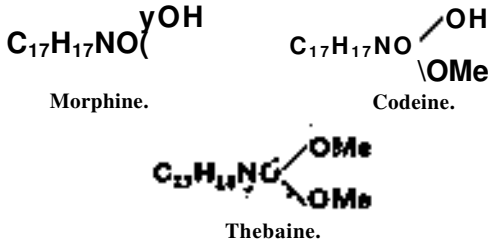

This close relationship is shown by the similarity of the products obtained by the treatment of thebaine on the one hand and codeinone on the other. Thus Howard and Roser found that with hot concentrated hydrochloric acid thebaine gave morphothebaine,  $C_{17}H_{17}O_8N$ . This base, which is similar in structure to apomorphine (Pschorr, Annalen, 1911, 382, 60), may also be obtained by treating codeinone in the same manner (Knorr, Ber. 1903, 36, 3074). With hot dilute hydrochloric acid thebaine yields a secondary base named thebenine,  $C_{18}H_{19}O_3N$  (Freund *ibid.* 1897, 30, 1357; 1899, 32, 168), and the same product is obtained from codeinone (Knorr, *l.c.*). A further resemblance is shown by the behaviour of the two substances in question towards hot acetic anhydride. Both yield ethanilmethylamine and thebaine gives in addition thebaol (I) a phenolic phenanthrene derivative (Freund and Gobel, *ibid.* 1895, 28, 941). This gives a methyl ether

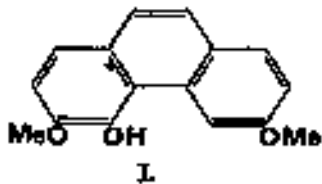

Vongerichten, *ibid.* 1902, 35, 4410), which is 3:4:6-trimethoxyphenanthrene (Pschorr (*ibid.*, p. 4400). Methylthebaol is also produced by methylating the 3:6-dihydroxyphenanthrene produced by the action of acetic anhydride on codeinone (Knorr, *l.c.*). Here the hydroxyl at position 4 is mentioned that by boiling thebaine with dilute sulphuric acid thebaine yields thebaol (Knorr *ibid.* 1895, 28, 941). This gives a methyl ether... reactions suggests that thebaine and thebaine possess the same four-

ringed skeleton, and that the two methoxyl groups of thebaine are situated at positions 3 and 6. The production of codeinone (II) may be explained by postulating that thebaine (III) is the methyl ether of the enolic form of codeinone.

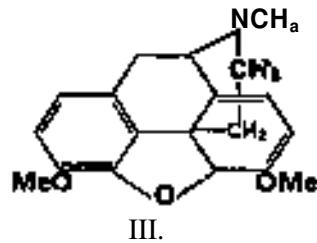
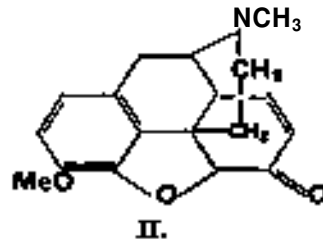

In the above formula, due to Gulland and Robinson (Mem. Manchester Phil. Soc. 1925, 69, 79), thebaine is represented as possessing two double bonds. In practice it is found that by catalytic hydrogenation a dihydro-compound is readily formed (*e.g.*, Freund and Speyer, Ber. 1920, 53 [B], 2250; Skita, *ibid.* 1921, 54 [B], 1560). Tetrahydrothebaine is produced with more difficulty (Schopf, Annalen, 1927, 452, 232). Dihydrothebaine is hydrolysed by boiling concentrated hydrochloric acid to the medicinally employed dihydrocodeinone ("Dicodide") (Freund and Speyer, *l.c.*). Aceticone, which is the acetyl derivative of enolic dihydrocodeinone, is also used in medicine.

Neopine,  $C_{18}H_{21}O_3N$ , was separated by T. and S. Smith in the form of hydrobromide, m.p. 282-283°, from final opium mother-liquids. Dobbie and Lauder (J.G.S. 1911, 99, 34) showed that it contained one methoxyl group and was a tertiary base and found that its absorption spectrum and colour reactions resembled those of codeine. Like codeine it was somewhat soluble in water. Van Duin, Robinson, and Smith (*ibid.* 1926, 903) found that it hydrogenated to give dihydrocodeine identical with the product from codeine itself, and on the basis of certain degradation reactions concluded that it was a structural isomer of codeine differing only in that the double bond occupied the position 8:14 instead of 7:8. "Although the salts with mineral acids showed a positive rotation, the base itself had  $[a]_D -28-1^\circ$  in chloroform."

**Pseudomorphine**,  $C_{18}H_{21}O_3N$ , was first isolated from opium by Pelletier (Annalen, 1835, 16, 27), though Hesse (*ibid.* 1867, 141, 87) describes the separation more fully. It is so easily formed by gentle oxidation of morphine, especially in alkaline solution, that it is doubtful whether it really occurs preformed in opium. It is best obtained by oxidising morphine with alkaline potassium ferricyanide (Vongerichten, *ibid.* 1896, 294, 206). Pseudomorphine, m.p.

327°, is sparingly soluble in the usual solvents but dissolves in pyridine or benzyl alcohol. The hydrochloride,  $[a]_D -103.1^\circ$  (in water), dissolves only to the extent of 1.4% in cold water, and the sulphate is even less soluble. The structure of pseudomorphine is not known with certainty. It has been formulated as a dimolecular product obtained by the carbon to carbon union of two morphine molecules in positions 1 or 2, but this does not explain why, of the four hydroxyl groups in the molecule, only one appears to be phenolic, or why the two nitrogen atoms should differ in behaviour (Small and Faris, J. Amer. Chem. Soc. 1934, 56, 1930). Small and Faris (*l.e.*) have prepared the four possible pseudomorphines by oxidation of the corresponding morphine isomers.

<sup>11</sup> **Porphyroxine**,  $C_{19}H_{23}O_4N$ .—Merck (Annalen, 1837, 21, 201) obtained a substance from Bengal opium to which he gave the above name. It appears to have been a mixture (Hesse, *ibid.* 1870, 158, 47). Later, Dey (Pharm. J. 1882, [iii], 12, 397) found that on treating an aqueous extract of Indian opium with ammonia and agitating with ether, the ethereal solution contained a substance which gave a rich purple colour with hydrochloric acid. He regarded this "porphyroxine test" as peculiar to Indian opium, but Bamford (Analyst, 1930, 55, 445) found that it was also given by Turkish opium. Bakshitt (J.C.S. 1919, 115, 445; Ber. 1926, 59 [B], 2473) has claimed the isolation of the base responsible for the colour reaction in a pure state. He described it as melting at 135°, being appreciably soluble in water, and having  $[a]_D -139.9^\circ$  in chloroform. It contained a tertiary nitrogen, a methoxyl group, an alcoholic hydroxyl, and a carbonyl group. Machiguchi (*Jo Pharm. Soc. Japan*, 1926, 529, 19) isolated from Japanese opium a substance agreeing in melting-point and other characteristics with porphyroxine, which on examination proved to be a mixture of codamine, meconidine, and laudanine. In spite of the precise details given by Bakshitt, Bajagopola (Current Sci. 1943, 12, 24) regards porphyroxine as being merely impure codeine.

#### (6) BENZYLISOQUINOLINE GROUP.

**Papaverine**,  $C_{20}H_{21}O_4N$ .—This alkaloid was discovered in morphine\* mother-liquors by Merck (Annalen, 1846, 66, 125; 1850, 73, 50), who analysed the base and assigned it the above formula.

**Properties.**—Rhombic prisms, m.p. 147°. Almost insoluble in water, sparingly soluble in ether, readily soluble in chloroform, benzene, and hot alcohol. Papaverine is very stable towards heat and can be sublimed. It is a weak monoacidic base and is optically inactive. The hydrochloride forms monoclinic crystals soluble in about 40 parts of water at 50° and melting about 220°. The acid oxalate, m.p. 196°, is sparingly soluble in alcohol and is often used to purify the base. Medicinally, papaverine exerts an antispasmodic effect on smooth muscle.

**Detection.**—Cold sulphuric acid dissolves it without coloration, but commercial samples may give a violet colour due to the presence of cryptopine (Pictet and Kramers, Ber. 1910, 43, 1329).

With sulphuric and iodic acids it gives a purple coloration changing to green. Warren (J. Amer. Chem. Soc. 1915, 37, 2402) has proposed the reaction of papaverine ferricyanide with MaTquis' reagent (formaldehyde in sulphuric acid) as characteristic. A light blue colour is obtained, which becomes violet, green, and finally a dirty yellow.

**Reactions and Constitution.**—Our knowledge of the constitution of papaverine is mainly due to Goldschmiedt (Monatsh. 1883, 4, 704; 1885, 6, 372, 667, 954; 1886, 7, 488; 1887, 8, 510; 1888, 9, 42, 327, 349).

He found that four methoxyl groups were present, for with hydriodic acid four equivalents of methyl iodide were formed, together with a phenolic substance, papaveroline. Oxidation with neutral permanganate gave veratric acid (I), pyridine-1:2:3-tricarboxylic acid (II), and an acid thought at first to be hemiaminic acid, but shown later to be metahemipinic acid (III).

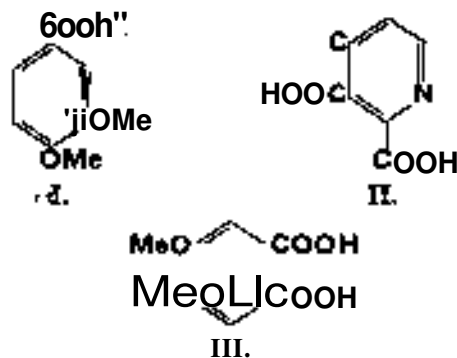

Alkaline fusion gave a neutral body and a base. The neutral compound was a dimethoxy toluene, the methyl group of which oxidised normally to carbonyl, giving veratric acid. The base was at first considered to be a dimethoxyquinoline. A little later, however, it was shown to be a dimethoxyisoquinoline (IV), for on oxidation it gave two products, namely metahemipinic acid and cinchomeronic acid (V) whereas a quinoline would have given only a pyridinecarboxylic acid.

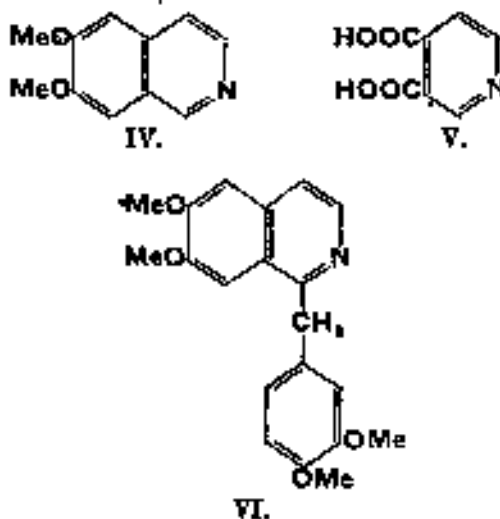

It was now evident that papaverine was built up from an isoquinoline nucleus united to a

nitrogen-free portion represented by the veratric acid\*. The point of union was evident from the permanganate oxidation, which had yielded pyridine-1:2:3-tricarboxylic acid as one product. Papaverine could therefore be represented as early as 1388 by the formula given above (VI). It was the first opium alkaloid the constitution of which was determined, and the first alkaloid shown to be an isoquinoline derivative.

Goldschmiedt had already shown that oxidation of papaverine with acid permanganate gave papaveraldine, a ketonic base, the molecule of which contained as many carbon atoms as the original substance. This could now be formulated by replacing the CH<sub>2</sub> link in papaverine by CO. It has been stated that papaveraldine is capable of reduction to papaverine with zinc and acetic acid (Stuchlik, Monatsh. 1910, 21, 813), but this could not be confirmed by Buck, Perkin, and Stevens (J.C.S. 1925, 127, 1462), who obtained the secondary alcohol papaverinol, which could be converted to papaverine by the action of hydrobromic acid in glacial acetic acid, followed by reduction with zinc dust.

Several reduction products of papaverine are known. The action of tin and hydrochloric acid leads to a mixture of pavine and tetrahydro-papaverine (Pyman, J.C.S. 1909, 95, 1610; 1910, 97, 1320; 1915, 107, 176). Pavine may be resolved into optically active components. These and other properties are explained by postulating the formula (VII).

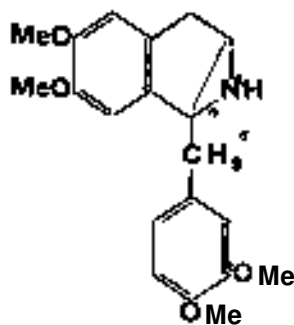

VII.

Papaverine has been synthesised on several occasions, the first complete synthesis being due to Pictet and Gams (Ber. 1909, 42, 2943). Voratrol was converted by the Friedel-Crafts reaction to acetoveratrone and the winitrosodervative of this, reduced with tin and hydrochloric acid, gave aminoacetoveratrone. Condensation with homoveratroyl chloride yielded nomoveratroyl- $\alpha$ -aminoacetoveratrone, which could be reduced to the alcohol (VIII). Under the influence of phosphorus pentoxide ring closure to papaverine took place (see also Rosen-

W. *Ann. Chem. Phys.* 1927, [1] 392; Mannich and Walther, *Arch. Pharm.* 1927, 265, 1; Buck, *Chem. Soc.* 1930, 52, 3610; Pictet and Gams, *Ber.* 1909, 42, 2943. In the latter

two syntheses 1:2-dihydro- and 3:4-dihydro-papaverine were produced, respectively. These, together with tetrahydro-papaverine may be synthesized from papaverine with the aid of phosphorus pentoxide (Pictet and Gams, *Ber.* 1909, 42, 2943).

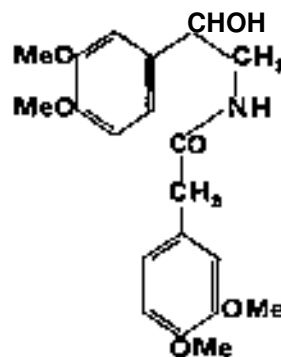

VIII.

Narcotine, C<sub>22</sub>H<sub>23</sub>O<sub>7</sub>N, occurs in opium as the free base in amounts varying from 1 to 10%, and was first isolated, in 1817, by Jobiquet, who extracted opium with ether.

*Properties.*—Prismatic needles, m.p. 176° (Hesse, *Annalen*, 1875, 178, 241). Almost insoluble in water and light petroleum. At 20°, 100 c.c. of saturated solution contain the following weights of narcotine in g.: ether 0.4, benzene 3.4, chloroform 45.9 (see also Bakshit, *Analyst*, 1921, 46, 481). Solubility in alcohol is 1 in 100 at 15°, 1 in 20 at 78°. [α]<sub>D</sub><sup>20</sup> -200° in chloroform (Perkin and Robinson, J.C.S. 1911, 99, 775). The salts are dextrorotatory. Narcotine is insoluble in cold alkalis; in hot alkali hydroxides it dissolves owing to the opening of a lactone ring (Babe and McMillan, *Annalen*, 1910, 377, 223). Narcotine is a feeble, monoacidic, tertiary base. The principal salts crystallise with difficulty, and from their solutions, even when strongly acid, solvents extract the free alkaloid to a considerable extent (Plugge, *Arch. Pharm.* 1887, 225, 343). The hydrochloride crystallises, with varying amounts of water, is rather soluble (about 1 in 4), and readily gives basic salts.

*Reactions and Constitution.*—Hydrolysis has been performed under both reducing and oxidising conditions and results in the splitting of the molecule into basic and non-basic portions. Thus nascent hydrogen converts narcotine to meconine and hydrocotarine (Beckett and Wright, J.C.S., 1875, 28, 573), and oxidation with dilute nitric acid gives opianic acid and cotarine (Anderson, *Annalen*, 1853, 86, 179).

Cotarine, C<sub>12</sub>H<sub>15</sub>O<sub>4</sub>N, is a methylated secondary base which gives an oxime and may be written (CHO)(OMe)(NMe)(C<sub>6</sub>H<sub>4</sub>O<sub>2</sub>). On oxidation, there results an o-dibasic acid named cotamic acid, which readily gives an anhydride and may be formulated

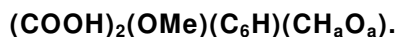

With hydriodic acid and phosphorus this compound yields gallic acid (3:4:5-trihydroxybenzoic acid), showing the presence of a methylenedioxy-group adjacent to methoxyl (Roser, *ibid.* 1888, 249, 156; 1889, 254, 359; Freund and Wulff, *Ber.* 1902, 35, 1737). The relative positions of the groupings were first shown by Freund and Becker, 1903, 36, 1521, who ascribed to cotamic acid the following formula (I) which was confirmed by synthesis (Perkin and Robinson, J.C.S. 1909, 95, 1977).

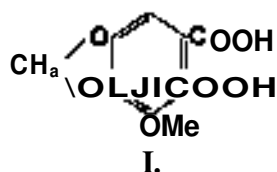

Evidently there were still two possible formula for cotarnine itself. Of these the following, (II), derived from a study of cotarnine anil, was regarded as most probable (Freund and Becker,

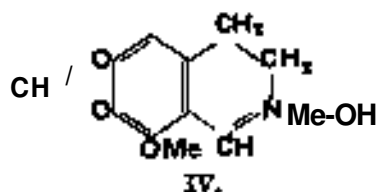
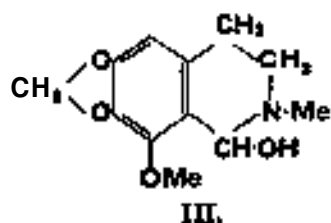
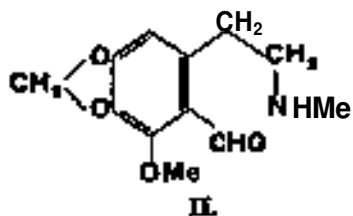

*I.e.*) Although cotarnine is usually represented as shown, it can also exist as a carbinol base (III) or an ammonium base (IV). (For the evidence regarding this matter afforded, by examination of the spectra of cotarnine solutions, see Dobbie, Lauder, and Tinkler, *ibid.* 1903, 83, 598; 1905, 85, 121). Formation of cotarnine salts is believed to take place with loss of water and ring closure, and reduction in acid solution to hydrocotamine may thus be considered as addition of hydrogen to the double bond.

Opifitic Acid (V) is a monobasic aldehydic acid, which from a study of its dibasic oxidation product, hemipinic acid, was formulated \* by Wegscheider as shown below (Monatsh. 1882, 8, 348; 1883, 4, 262). On reduction it gives

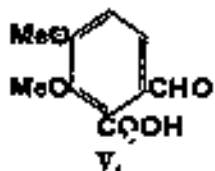

*meconine*, which is the lactone of the corresponding alcohol (Matthiessen and Foster, J.C.S. 1863, 8, 342; Wright, *ibid.* 1876, 29, 170). Opianic acid, hemipinic acid and meconine have been synthesised by Perkin (*ibid.* 1925, 127, 196). "

. From a consideration of the formula assigned to opianic acid and hydrocotamine, Rose? in 1889 proposed the following formula for narcotine (VI). This was eventually confirmed by the synthesis, described by Perkin and Rofcinson (*ibid.* 1911, 99,7/5), who succeeded in ^reducing dZ-narcotine by boiling meconine and cotarnine together in alcohol.

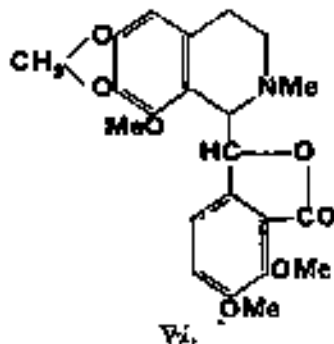

GnoscoDine,  $C_{26}H_{23}O_7N$ .—This \*as first obtained from opium by T. and H. Smith (Pharm. J. 1878, [iii], 9, 82). It formed white woolly needles, m.p.  $233^\circ$ , from alcohol. In 1893 the same authors showed that when narcotine was heated with acetic acid it was partly converted into gnoscopine *ibid.* 3893, [iii], 23, 794), and later Rabe and McMillan (Ber. fdO, 43, 800) and Perkin and Robinson (J.C.S. 1911, 99, 775) showed that gnoscopine was in fact *dl*-narcotine. The last-mentioned authors succeeded in resolving gnoscopine with *rf*-bromocamphorsulphotic acid and accomplished its synthesis by condensing cotarnine and meconine.

Codamine,  $C_{20}H_{26}O_4N$ .—Isolated by Eesse (Annalen, 1870, 158, 47), this strongly basic alkaloid crystallises in six-sided prisms from ether or ligroin, m.p.  $126^\circ$  (Hesse, Ber. 1871, 4, 693) and gives amorphous salts. It contains one phenolic hydroxyl group in position 7 of the troquinoline nucleus, and three methoxyl groups. Spath and Epstein, who demonstrated the above facts, also achieved the synthesis of the racemic alkaloid and showed that natural codamine gives (Maudanosine or) methylation (*ibii.* 1926, & [B], 2791; 1928, 61 [B], 334).

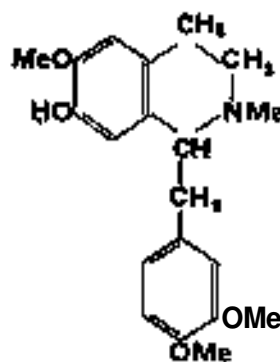

<sup>11</sup> Pseudopapaverine "—Hesse (Annalen, 1870, 153, 47) claimed the isolation of this alkaloid, which, however, was demonstrated by Späth and Polgar to be papaverine (Ber. 1926, 59,2787).

**Narcotine**,  $C_{21}H_{27}O_7N$ .—This, the most recently discovered of the opium alkaloids, was found in poppy capsules by Wrede (Arch. f. exp. Path. Pharm. 1937, 184, 331). It was isolated by means of the sparingly soluble *acid tartrate*, m.p. 202°. The base itself possessed  $[a]_D -189^\circ$  in chloroform, in which it was easily soluble, while the solubility in ether and alcohol was less marked. It was found to be a partially demethylated narcotine, having one hydroxyl group in the cotarnine half of the molecule, and giving rise to narcotine on treatment with diazomethane. The physiological action resembled that of narcotine but was weaker.

"Xanthaline",  $C_{20}H_{19}O_6N$ .—First isolated from opium by T. and H. Smith (Pharm. J. 1895, [iii], 23, 793). Subsequently Dobson and Perkin (J.C.S. 1941, 99, 135) showed that this base, m.p. 210°, was identical with papaveraldine, a simple oxidation product of papaverine in which the CH<sub>2</sub> link between the benzene and isoquinoline nuclei is replaced by a carbonyl. The base is a very weak one and its name is derived from the fact that it forms intensely yellow salts.

Laudanosine,  $C_{21}H_{27}O_4N$ .—Hesse, found traces of this alkaloid in opium (Ber. 1871, 4, 93). Later it was shown that when papaverine methochloride is reduced with tin and hydrochloric acid it furnishes *N*-methyltetrahydro-papaverine, m.p. 113°, and this on crystallisation of the quinone separates into the *d*- and *l*-bases, the former being identical with natural laudanosine. It crystallises from ligroin in needles, m.p. 89°, and is very soluble in chloroform, ether, and alcohol.  $[o]_D +103.2^\circ$  in alcohol. Laudanosine is more poisonous than papaverine and somewhat resembles the latter in physiological action; it exerts no narcotic effect (Pictet and Athanasescu, *ibid.* 1900, 88, 3346; *ibid.* 1909, 95, 1610). A synthesis of laudanosine has been effected by Pictet and Winkelstein (Compt. rend. 1909, 148, 925). For the preparation of products of laudanosine, see Pyman (Ann. Pharm. 1909, \* 1266) and Gadamer and Kondoh (Ann. Pharm. 1915, 253, 28). The conversion of laudanosine is given by Pschorr, Ber. 1904, 37, 444, and Gadamer (Arch. Pharm. 1911, 249, 68G\*).

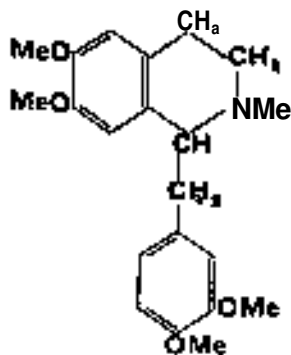

**Oxynarcotine**,  $C_{22}H_{23}O_8N$ .—This alkaloid was first isolated by Mayer (Proc. Phil. Soc. Glw. J. C. S. 1878, 29, 131) and by Beckett and Wright (J. C. S. 1878, 29, 131) from impure narceine. It is identical with the *l*-form of cotarnine and is a dihydro-isoquinoline derivative.

and McMillan (Annalen, 1910, 377, 223) conjectured that oxynarcotine and nornarceine were the same, but differences in solubility and in the water of crystallisation held by the two bases and their hydrochlorides make this doubtful.

Laudanine,  $C_{20}H_{26}O_4N$ .—This was found in minute amounts in the alkaline mother-liquors from morphine extraction (Hesse, *ibid.* 1870, 153, 47). The base forms rhombic prisms, m.p. 166°, from alcohol. It contains three methoxyl groups and one phenolic hydroxyl group, and gives a green coloration with ferric chloride. The structure is shown by the fact that it gives a mixture of laudanine methiodide and dMaudanosine on methylation (Hesse, J. pr. Chem. 1902, [ii], 65, 42; cf. Späth, Monatsh. 1920, 41, 297). This base presents one of the rare examples of natural occurrence of the racemic form of an alkaloid. It has been synthesised by Späth and Lang, Monatsh. 1921, 42, 273.

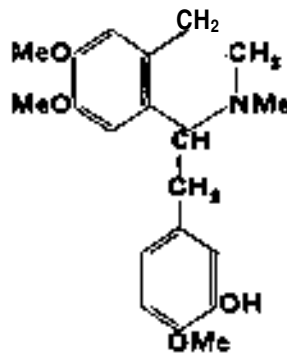

•• Laudanidine,  $C_{20}H_{15}O_4N$ .—Hesse (Annalen, 1894, 282, 208) found an optically active impurity in the mother-liquors from natural laudanine hydrochloride which possessed the same molecular formula as laudanine and gave the same colour reactions. He surmised that the new alkaloid, which he termed laudanidine, was in reality Maudanine. Later, Späth and Burger (Monatsh. 1926, 47, 733) synthesised the two enantiomers of laudanine by demethylating the corresponding optically active laudanosines. They found that Maudanine was identical with laudanidine and that a mixture of equal amounts of *d*- and Maudanines gave a product corresponding to natural laudanine, thus proving Hesse's conjecture. The base has m.p. 184-185° and  $[a]_D -100^\circ$  in chloroform (Späth, Ber. 1925, 58 [B], 200, 1272), and cannot be racemised by the most drastic treatment. Späth also showed that the alkaloid *tritopine*, isolated by Kauder (Arch. Pharm. 1890, 288, 419) is the same as laudanidine. Narceine,  $C_{23}H_{27}O_8N$ , occurs in opium to the extent of 0.1-0.4%. Owing to its amphoteric nature narceine remains dissolved in aqueous extract of opium during the process of removal of the other principal alkaloids. It may be recovered from the final mother-liquors by the method described by Anderson (Annalen, 1853, 86, 182) who, however, was not the discoverer of this alkaloid, that honour falling to Pelletier (*ibid.* 1833, 5, 163). Freund and Frankforter (*ibid.* 1893, 277, 20) first established the true empirical formula.

**Properties.**—Crystallises in white silky needles containing  $3\text{H}_2\text{O}$  and melting at  $170^\circ$  from water or 80% alcohol, in both of which it is very sparingly soluble in the cold. The monohydrate is obtained by heating at  $100^\circ$  and melts indefinitely at  $140\text{--}146^\circ$ . The anhydrous base melts at  $145^\circ$  (Hesse, *ibid.* 1864, 129, 250), and, unlike the trihydrate, is soluble in chloroform and benzene. Narceine is optically inactive and has no marked physiological action. It is a very weak monacidic base which forms well-crystallised salts with acids. The best known of these is the *hydrochloride*, which may contain varying amounts of water of crystallisation. This salt may be obtained anhydrous at  $120^\circ$  and then melts at  $188\text{--}192^\circ$ . Narceine is also a weak monobasic acid, and *potassium* and *sodium* salts, melting at  $90^\circ$  and  $160^\circ$  respectively, may be prepared in crystal form by adding ether to their alcoholic solutions (Freund, *l.e.*). Freund also found that with boiling alcoholic hydrogen chloride the hydrochloride of the ethyl ester was formed, m.p.  $206\text{--}207^\circ$ .

With methyl iodide, narceine methyl-ester methiodide,  $\text{C}_{23}\text{H}_{21}(\text{CH}_3)_2\text{O}_8\text{N}, \text{CH}_3\text{I}$ , m.p.  $193\text{--}194^\circ$  is produced.

**Reactions and Constitution.**—Narceine gives with chlorine-water, followed by ammonia solution, a blood-red colour. Alone among opium alkaloids it gives an intense bluish colour and precipitate with weak iodine solution, which is destroyed by those media dissolving narceine.

Narceine contains three OMe groups (Freund) and one  $\text{NMe}_2$  group (Herzig and Meyer, *Monatsh.* 1895, 16, 599) which shows that the N does not form part of a ring but stands at the end of a chain. It contains the grouping  $\text{C}_6\text{H}_4\text{—C}_6\text{H}_3$ , for it is possible to obtain an wonitroso derivative, and with hydroxylamine the anhydride of the normal oxime is formed (Freund, *Ber.* 1909, 42, 1084). The constitution of narceine is established by the fact that it may be prepared by heating narcotine methochloride with tükalis.

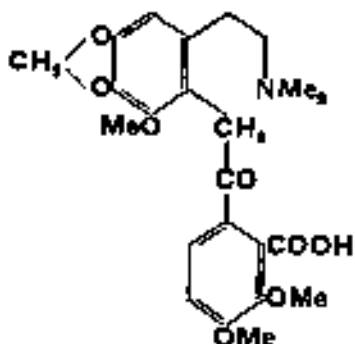
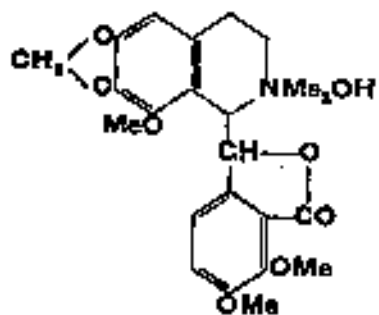

In practice, the transformation is more advantageously performed by boiling narcotine and methyl *jj*-toluenesulphonate in dilute alkali (Rodionov, *BuU. Soc.* 1926, [iv] 39, 305).

In addition to the papers already mentioned, the following may be consulted: Bosef, *Annalen*, 1888, 247, 169; AddinaU and Major, *J. Amer. Chem. Soc.* 1933, 55, 1202.

(c) "DLWOQUINOLINE" ALKALOIDS.

**Cryptopine**,  $\text{C}_{21}\text{H}_{23}\text{O}_6\text{N}$ .—This optically inactive alkaloid was first isolated by T. and H. Smith (*Pharm. J.* 1867, [ii], 7, 595, 716). Watt found as much as 0.3% in Indian opium (*ibid.* 1918, 100, 147). The base crystallises from alcohol in prisms, m.p.  $218^\circ$ , and the salts form jellies which crystallise only on long standing. The *hydrochloride* melts and decomposes at  $235^\circ$ . W. H. Perkin (jun.) in an exhaustive investigation deduced the subjoined formula (*J.C.S.* 1916, 109, 816; x919, U5, 713).

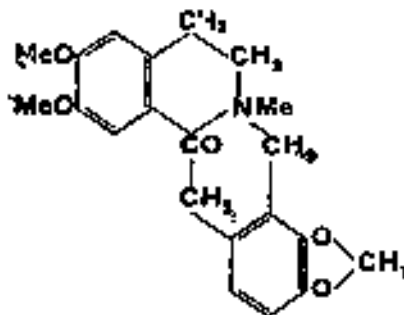

The synthesis was effected by Haworth and Perkin (*ibid.* 1926, 1769). It is difficult to free papaverine completely from traces of cryptopine and many colour reactions once ascribed to papaverine, such as the dark blue-violet colour with concentrated sulphuric acid, have been shown to be due to traces of cryptopine (Pictet and Kramers, *Ber.* 191 A, 1329).

**Protopine**,  $\text{C}_{20}\text{H}_{19}\text{O}_6\text{N}$ .—This alkaloid has been found in at least 23 papaveraceous plants and is best obtained from the root of *Dicentra spectabilis*, which contains almost 1% of the base (Danckwortt, *Arch. Pharm.* 1912, 200, 590). The laborious separation from opium was carried out by Hesse (*Ber.* 1871, 4, 693). Protopine forms colourless monoclinic prisms, m.p.  $208^\circ$ , which are sparingly soluble in cold alcohol or ether. Perkin (*J.C.S.* 1916, 109, 815) showed that it differed from cryptopine only in possessing a methylenedioxy-grouping in place of the two methoxyls.

(d) TETRAHYDROQUINOLINE ALKALOIDS.

**Hydrocotarnine**,  $\text{C}_{18}\text{H}_{16}\text{O}_3\text{N}$ .—Hesse found this alkaloid in opium mother-liquors (*Annalen Suppl.* 1872, 8, 261), but it is not certain whether it exists preformed in opium, as Beckett and Wright (*J.C.S.* 1875, 28, 573) have reported that it is produced by the hydrolysis of narcotine with water at  $140^\circ$ . A more convenient preparation is by the reduction of cotarnine with zinc and hydrochloric acid (Beckett and Wright, *l.c.*).

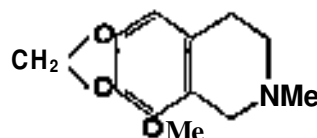

Hydrocotarnine has m.p. 56° and normally crystallises with ½H<sub>2</sub>O, which is lost just above the melting-point. It may be purified through the *hydrobramide*, m.p. 236°. Treatment with sodium alcohol leads to replacement of the methoxyl group by hydrogen (Pyman and Remfry, *ibid.* 1912, 101, 1595), giving *hydrohydraqtinine*, which may be oxidised to the medicinally employed *hydrastinine*.

(e) BASES OF UNKNOWN CONSTITUTION.

Lanthopine, C<sub>23</sub>H<sub>25</sub>O<sub>4</sub>N.—Discovered by Hesse (Annalen, 1870, 153, 47). It is almost insoluble in alcohol or ether, fairly soluble in chloroform. Lanthopine is a very weak base which appears to contain a phenolic group, >r it dissolves in alkali. It gives no ferric chloride reaction, however. M.p. ca. 200° (Machiguchi, J. Pharm. Soft Japan, 1926, 529, 185, reports a m.p. of 141-145°).

Meconidine, C<sub>21</sub>H<sub>23</sub>O<sub>4</sub>N.—Also isolated by Hesse (J.c). It was found in the ether Extract of the mother-liquor obtained by precipitating an aqueous infusion of opium with soda. The alkaloid, of doubtful purity, formed a dark-yellow amorphous mass of m.p. 58°. It was very soluble in organic solvents and in alkalis. Machiguchi (Z.c) has also reported its existence.

Papaveramine, C<sup>14</sup>H<sup>16</sup>O<sup>4</sup>M.—This very weak base was isolated by Hesse (J. pr. Chem. 3, [ii], 68, 204). It was separated from crude papaverine by precipitating the latter as thiocyanate from a solution of the mixed oxalates, and then adding sodium hydroxide to the filtrate. Papaveramine crystallises from alcohol or ether in colourless prisms melting at 128-129° and gives a intense blue-violet solution with sulphuric acid.

NEUTRAL AND ACIDIC SUBSTANCES IN OPIUM.

Meconine, C<sub>17</sub>H<sub>19</sub>O<sub>4</sub>, was discovered by Dublanc (Ann. Chem. Phys. 1832, [iii], 49, 6; Couerbe, *ibid.*, p. 44; Anderson, Annalen, 1866, 98, 44). It is also produced, together with narcotarnine, by the reduction of narcotine (Beckwith and Wright, J.P.C.S. 1875, 28, 479). Meconine crystallites from water in prisms melting at 102°, and dissolves slowly in alcohol to form a solution of meconino acid, of which it is the lactone; its constitution is represented by the

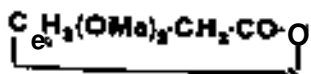

1876, 29, 170, Hesse, Ber. Meconine has been synthesised by Fritsch (Annalen, 1898, 801, 352), and more recently by Soyé (Compt. Rend. Acad. Sci. Paris, 1902, 34, 102). Meconine was isolated by T. and H. Smith in the mother-liquors from the preparation of meconine. It is crystalline and has m.p. 88°. Meconic Acid, C<sub>7</sub>H<sub>9</sub>O<sub>7</sub>, 3H<sub>2</sub>O.—This is the characteristic acid of opium and is contained therein in amounts varying from 3 to 6% (Heiduschka, Arch. Pharm. 1911, 255, 493). It is prepared from meconine by addition of lead acetate to an aqueous solution of the drug, suspending the

precipitate in water, and decomposing it by a stream of hydrogen sulphide. The filtered solution, after concentration and acidification with hydrochloric acid, deposits the acid.

Meconic acid crystallises in micaceous plates soluble in 4 parts of boiling water. It is regarded as a pyrone derivative of formula (I). On heating to 120-200° carbon dioxide is lost, giving *comenic acid* (II), while on further heating or dry distillation *pyromeconic acid* (III) is produced (Bobiquet, Ann. Chim. Phys. 1832, [ii], 5f, 245; 1833, 53, 428). It is possible to replace the heterocyclic oxygen in these compounds with imino by the action of concentrated ammonia (How, Annalen, 1852, 83, 353). The ring structure of meconic acid is disrupted by

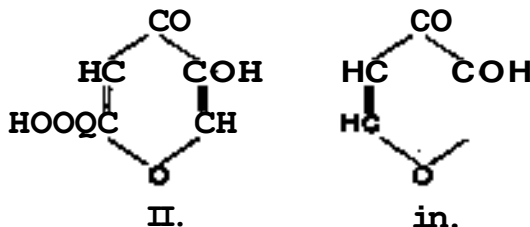
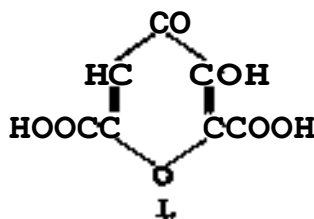

catalytic reduction giving a tetrahydroxypimelic Acid, COOH-[CH(OH)]<sub>3</sub>-CH<sub>2</sub>-CH(OH)-COOH, while comenic and pyromeconic acids reduce normally to pentamethylene oxide derivatives (Borsche, Ber. 1916, 49, 2538).

Meconic acid, though strictly speaking dibasic, is capable of forming yellow salts of a tribasic character. It titrates as a dibasic acid towards Methyl Orange, but as a tribasic acid towards Poirriers Blue. With ferric chloride it gives a deep red colour, not destroyed by cold dilute hydrochloric acid or by mercuric chloride. This property has been useful on occasion in deciding whether poisoning was due to opium or a morphine salt.

"Thebolactic Acid<sup>M</sup>, of T. and H. Smith (Pharm. J. 1866, [5], 7, 50), has been shown to be identical with ordinary *lactic acid*.

Other acids have been reported in traces, such as acetic acid. Schmid and Karrer (Helv. Chim. Acta, 1945, 22, 1187) are engaged in the examination of the minor water-soluble constituents of *Papaver somniferum*, and traces of many interesting compounds have been isolated. As the source is poppy waste rather than opium these will not be enumerated.

Literature.

Fuller information on the opium alkaloids may be found in T. A. Henry's "Plant Alkaloids," 3rd ed., Churchill, 1939; and also in L. F. Small's "Chemistry of the Opium Alkaloids," U.S. Treasury Dept., Public Health Service, which, however, was published in 1932. J. R. Nicholls' Streatfield Memorial Lecture, 1938, E.I.C. Publication, is also of interest.

H. B. W. and B. G. J.

**OPTICAL ACTIVITY.** Introduction. —Certain substances possess the property of rotating the plane of polarisation when placed in the path of a beam of plane-polarised light. Apart from its intrinsic physical interest, this property, called "optical activity" or "optical rotatory power," is of particular significance to structural chemistry, since it furnishes information concerning the symmetry of crystals and molecules. The absence of reflection symmetry in a crystal or in the molecules of a liquid or solution is a necessary condition for optical activity.

**Optical activity was discovered by Biot (Mém. Inst. 1812, 1, 1),** who described and interpreted the phenomenon of rotatory polarisation in quartz. In 1815, he reported the discovery of optical activity in liquids and solutions (Boll. Soc. Philomath 1815, 190). Fresnel (*ibid.* 1824, 147), gave a phenomenological theory of rotatory polarisation. He showed that a beam of plane-polarised light could be regarded as composed of two beams of left and right circularly polarised light of equal amplitude. In transit through a medium possessing different refractive indices for right and left circularly polarised light, a phase difference between the two circular components of a plane-polarised beam is produced which is equivalent to a rotation of its plane of polarisation.

Pasteur's resolution of sodium ammonium racemate into its optical isomers (*cf.* Alembic Club Reprints, 14, 17, 19), and his ideas concerning molecular dissymmetry (*ibid.*, p. 26A, suggested by observation of the hemihedral character of optically active crystals, led naturally to the formulation of the principles of stereochemistry by Le Bel (Bull. Soc. chim. 1874, [ii], 22, 337) and J. H. van't Hoff ("La Chimie dans L'Espace," 1875). In modern stereochemistry, built upon these foundations, the phenomenon of optical activity continues to play an important rôle.

**Polarised Light.**—According to the theory of Maxwell, a beam of parallel light traversing an isotropic transparent medium consists of a plane electromagnetic wave, in which the electric and magnetic field vectors  $E$  and  $H$  are of equal magnitude, perpendicular to each other and to the direction of propagation (transversality). By the principle of superposition the field vectors may be resolved into their Fourier components, each of which is monochromatic of specified frequency  $\nu$ . The field vector  $E$  of a plane electromagnetic wave, advancing in the direction of the  $z$ -axis, may be resolved into its components along two orthogonal axes,  $x$  and  $y$ , in a plane perpendicular to the  $z$ -axis in the following manner [*see, e.g.,* M. Born, "Optik," Berlin, 1933):

$$\begin{aligned} E_x &= A_x e^{i(\omega t - kz)} + c.c. \\ E_y &= A_y e^{i(\omega t - kz)} + i c.c. \\ r &= 1 - \frac{v^2}{c^2} \quad \omega = 2\pi\nu \\ r\lambda &= \lambda \end{aligned}$$

where  $t$  is the time,  $n$  the refractive index of the medium,  $\lambda$  the wave-length of the light beam, and  $c$  the velocity of light in vacuum. The amplitudes  $A_x$  and  $A_y$  and the phase constants

$h_x$  and  $h_y$  are real constants. According to convention, the real parts of the complex exponentials ( $e^{i\omega t} = \cos \omega t + i \sin \omega t$ ;  $i = \sqrt{-1}$ ) represent the physically significant parts of  $E_x$  and  $E_y$ . The respective components of the magnetic field vector,  $H_x$  and  $H_y$ , are equal in magnitude and perpendicular to those of  $E$ .

The state of polarisation of the light is determined by the phase difference  $\delta_x - \delta_y$ . When the phase difference of the  $x$  and  $y$  components is arbitrary, but constant, the light is said to be elliptically polarised. When viewed at a fixed point in the path of the light, the terminus of the rotating electric vector would be observed to describe an ellipse. When viewed in space at a given instant of time, the termini of the electric vectors would be observed to lie on an elliptic spiral with its axis parallel to the direction of propagation. When the phase difference  $h_x - h_y$  is equal to  $\pm \pi/2$ , and  $A_x = A_y$  the light is circularly polarised. The termini of the electric vectors describe circles at a fixed point in space and form a circular spiral at a fixed instant of time. There are two types of circular polarisation. By convention, right circular polarisation corresponds to clockwise rotation (and left circular polarisation to counter-clockwise rotation) of the electric vector when viewed counter to the direction of propagation of the light. However, in the literature of optics, it was formerly conventional to define right and left circular polarisation in the opposite sense. When the phase difference  $\delta_x - \delta_y$  is equal to  $\pm \pi$ , the light is linearly or plane-polarised. The electric vector does not rotate, but remains in a fixed plane containing the direction of propagation. This plane may be called the plane of polarisation, although the older convention designates the plane of the magnetic vector and the direction of propagation as the plane of polarisation. By the superposition principle, arising from the linearity of Maxwell's equations, a plane-polarised beam of light may be regarded as composed of two beams of right and left circularly polarised light of equal amplitude.

In unpolarised light, the phases  $h_x$  and  $h_y$  are uncorrelated, and the squares of the amplitudes  $A_x^2$  and  $A_y^2$  are equal. Unpolarised light is to be regarded as the result of superposing signals from a large number of sources (excited atoms and molecules) of random phase. It may be formally described as consisting of two beams of light, of equal amplitude and uncorrelated phase, polarised in perpendicular planes.

The principal methods for producing polarised light utilise double refraction by anisotropic crystals and reflection from the surfaces of liquids and solids.

When a beam of unpolarised light is reflected from a surface, *e.g.*, that of a glass plate, the reflected ray is plane-polarised when the angle of incidence is equal to the Brewster angle, the tangent of which is equal to the ratio of the refractive indices of the two media, at the boundary between which reflection occurs.

The most common polarising instrument utilising double refraction is the Nicol prism (Nicol, New Phil. J. Edinburgh, 1828, 6, 83; *see, e.g.,* T. M. Lowry, "Optical Rotatory



Power," Longmans, 1935). The natural end-faces of a crystal of calcite are ground until the angles in a principal section are reduced from  $71^\circ$  to  $68^\circ$ . The crystal is then cut diagonally in a plane perpendicular to the principal section and perpendicular to the new end faces. The two pieces are then cemented together with a film of Canada balsam, which has a refractive index intermediate between those of calcite for the ordinary and extraordinary rays. A beam of unpolarised light incident on an end face of the Nicol prism at an angle of incidence of less than  $14-15^\circ$  with the long side of the prism, is split into the ordinary and extraordinary ray by double refraction; the extraordinary ray is totally reflected at the Canada-balsam interface, and the ordinary ray is transmitted as a beam of plane-polarised light.

The instrument used for the measurement of optical rotatory power is called a polarimeter. Schematically, a polarimeter consists of a polarising Nicol prism, through which parallel monochromatic light from a suitable source, such as B-, sodium-vapour lamp or a mercury arc, is passed. The polarised light is then passed through a small half-shadow Nicol, which creates a difference in intensity in the two halves of the beam. The beam then passes through a specimen of the substance under investigation, after which it reaches the analysing prism, which is rotated until the two halves of the field are of equal intensity. The *specific rotation*  $[\alpha]$  of an optically active substance is defined as the rotation in degrees produced per decimetre of light path per gram of substance per cubic centimetre. The *molecular rotation* of a substance is defined as the product of its specific rotation and its molecular weight. The specific rotation  $[\alpha]$  depends in general upon the frequency of the light. The variation of  $[\alpha]$  with frequency or wave-length is called *rotatory dispersion*.

Unusually polarised light may be produced by passing plane-polarised light through a Fresnel rhomb or a quarter-wave plate. Both instruments depend on resolving the electric vector of the plane-polarised ray into two perpendicular components of equal magnitude and producing a phase difference of  $\pi/2$  between them.

**Optical Activity and Molecular Structure**—Molecules may be classified according to their symmetry, described by the group of 23 rotations (point group) of reflection, inversion, if the molecule contains atoms of identical symmetry, by permuting the positions of identical atoms. In the geometrical representation of a point group, the elements are planes and centres of symmetry. A molecule is said to be optically active if it lacks a plane of symmetry or a centre of symmetry. A dissymmetric molecule does not possess elements of rotation symmetry. Pasteur attributed optical activity in liquids to molecular dissymmetry, a theory confirmed by the molecular theories of optical activity of Born and others, and by the optical activity of optically active crystals, demonstrated by the crystal structure of quartz or may not be present in the same molecule. Hemihedral crystals show optical activity. The hemihedral character of crystals is not always evident from

macroscopic crystallographic examination, but may require detection by other tests based, e.g., upon the pyroelectric or piezoelectric effects.

The structural basis for molecular dissymmetry is to be found in the concept of directed valence. This was the brilliant suggestion of van't Hoff, who advanced the hypothesis that the four valence bonds of the carbon atom were directed from the centre towards the vertices of a regular tetrahedron. The stereochemistry of organic molecules rests firmly upon the concept of the tetrahedral carbon atom.

The most common dissymmetrical structural element of organic molecules is the asymmetric carbon atom, to which are bonded four different organic radicals (I). A molecule containing one

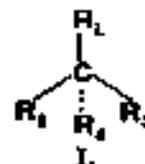

asymmetric carbon atom possesses two isomeric structures, which are mirror images of each other. The two isomers are called optical isomers or enantiomorphs. Their ordinary physical and chemical properties are identical, but their optical rotations are opposite in sign. The enantiomorph with positive rotation is called dextro-rotatory, and the one with negative rotation is levo-rotatory. When a potentially active compound is prepared from optically inactive materials, an optically inactive product called a *racemate* is always obtained. The racemate is an equimolar mixture of the two enantiomorphs. As a simple example of a compound containing one asymmetric carbon atom, lactic acid (v. Vol. VII, 161c) may be mentioned.

A compound containing two different asymmetric carbon atoms has four isomers, consisting of two pairs of optical isomers. The physical and chemical properties of the two pairs are different. A member of one pair is called a diastereoisomer of a member of the other pair. An example of such a compound is *α*-bromo-*o*-methyl valeric acid. When the two asymmetric carbon atoms are identical, only three isomers are obtained, a pair of optical isomers and a meso-compound which is inactive. Tartaric acid is an example of such a compound. A compound containing  $n$  different asymmetric carbon atoms has  $2^{n-1}$  diastereoisomeric pairs of optical isomers.

Optical activity in organic compounds is not confined to those containing asymmetric carbon atoms. The substituted allene

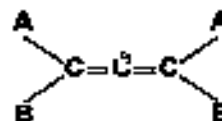

although possessing a two-fold axis of symmetry, are dissymmetric, as was recognised by van't Hoff. However, it is only in recent years that an optically active compound of this type has been successfully prepared (Maitland and Mills, *Nature*, 1935, 135, 994; J.C.S. 1936, 987). The

bipiranes, in which the double bonds of an allene are replaced by methylene rings, are also optically active, and have been successfully resolved (Janson and Pope, Chem. and Ind. 1932, 51, 316). Owing to the non-coplanar character of their rings, certain isomers of the substituted cycloparaffins are optically active, e.g., inositol, which is hexahydroxycyclohexane (v. Vol. VI, 494a).

Many optically inactive molecules can assume dissymmetric configurations by internal rotation around single bonds. Since each such configuration has an enantiomorphous configuration, the molecule is inactive when rotation about the single bonds is free, in the sense that potential barriers hindering rotation are low relative to the product of Boltzmann's constant and the absolute temperature. When rotation is hindered, as in certain substituted diphenyls, resolution into optical isomers is possible. An example of such a compound is 1:1'-dinitrodiphenyl-5:5'-dicarboxylic acid,

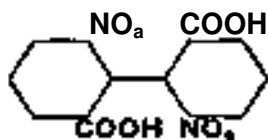

(see Christie and Kenner, J.C.S. 1922, 121, 614). The rate of racemisation is higher the lower the potential barrier hindering rotation.

Many inorganic molecules exhibit optical activity. Among them may be mentioned coordination compounds, for which Werner suggested the octahedral model (v. Vol. III, 3306). Co-ordination compounds with a planar distribution of valencies do not exhibit optical activity, since they cannot have molecular dissymmetry.

Although optically active compounds can be isolated from living organisms, the synthesis of a dissymmetric compound from inactive materials always leads to the *dl*- or racemic mixture. Among the methods of resolution of a racemic mixture are mechanical separation of the crystals, conversion to diastereoisomers by reaction with an optically active compound with subsequent fractionation and decomposition, and selective adsorption on optically active crystals such as quartz. The second method is the most commonly used, in the resolution of a racemic acid *dl*-A, its salt with an optically active base, e.g., 2-brucine, is first prepared,

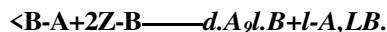

The two salts, being diastereoisomers, have different physical properties, and with a suitable choice of the base B, may be separated by fractional crystallisation. After the fractional crystallisation, *d*-A and *Z*-A are split off by treating the salts with a mineral acid or alkali. Racemic alcohols are first converted to their acid phthalate or succinate esters, and the acid esters resolved in the manner described above.

Asymmetric syntheses involving photochemical reactions under the influence of circularly polarised light have been successfully attempted (Kuhn and Knopf, Naturwiss. 1929, 17, 227). (For a comprehensive treatment of the material summarised in this section, see

H. Gilman, "Organic Chemistry," 2nd ed., New York, 1943, Vol. I, p. 214).

Molecular Theories Of Optical Activity. —The propagation of light in an isotropic optically inactive transparent substance is determined by Maxwell's equations and one parameter  $n$ , the refractive index of the substance. According to Fresnel, two refractive indices  $n_r$  and  $n_l$  for right- and left-circular polarisation are required in the case of optically active substances. The rotation  $\theta$  of the plane of polarisation is

$$\theta = \frac{2\pi}{\lambda} (n_r - n_l) l$$

where  $\lambda_0$  is the wave-length of the light in vacuum. Extraordinarily small differences,  $n_r - n_l$  of the order of  $10^{-6}$ , suffice to account for relatively large specific rotations  $[\alpha]$ . The object of molecular theories of optical activity is to relate the refractive index difference  $\frac{n_r - n_l}{n}$  to the structure of the molecules of optically active substances.

When viewed from the molecular standpoint, the propagation of light in a material medium may be described in the following terms. An oscillating electric dipole moment and a corresponding magnetic moment are induced in each molecule by the electric and magnetic fields of the light. The molecule then becomes an emitter of radiation, a part of which is coherent (related in phase) with the primary light. The light wave propagated in the material is the result of superposing upon the primary wave the secondary waves from all the molecular sources. The explanation of optical activity is therefore to be sought in an investigation of the dependence of the induced electric and magnetic moments of a dissymmetric molecule on the field vectors of the light wave. If the phase  $z/\lambda$  of the light (see p. 1166) is assumed constant over the region occupied by a molecule, no optical activity is found. Only when retardation or the finite time of travel of the light from point to point in the molecule is considered does optical activity appear, and, in fact, the contribution of an individual dissymmetric molecule to the rotatory power of a liquid or solution is found to be proportional to the square of the ratio of a length of molecular dimensions to the wave-length of the light. Thus optical activity arises as a small correction to ordinary dispersion theory, and it is not surprising that the differences between the refractive indices for right- and left-circularly polarised light are usually very small.

A molecular theory of optical activity was first formulated by M. Born (Physikal. Z. 1915, 16, 251; "Optik," Berlin, 1933, p. 405) and Oseen (Ann. Physik, 1915, [iv], 48, 1), on the basis of the classical oscillator theory of dispersion. The theory was extensively applied by Kuhn (see W. Kuhn and K. Freudenberg, "Drehung der Polarisationsebene des Lichtes," Leipzig, 1932) using a simplified model consisting of two anisotropically-coupled oscillators. With the advent of quantum mechanics the theory was reformulated by Rosenfeld (see M. Born and P. Jordan, "Elementare Quantenmechanik," Berlin, 1930, p. 250). Paralleling the Born theory, probability theories of optical activity, starting

directly from the forced vibrations produced in a molecule by the radiation field, were proposed by Gray (Physical Rev. 1916, [ii], 7, 472); de Malleman (Rev. Gen. Sci. 1927, 38, 453); and Boys (Proc. Roy. Soc. 1934, A, 144, 655, 675). Kirkwood (J. Chem. Physics, 1937, 5, 479) established the relationship between the polarisability\* theories and the quantum-mechanical theory, by approximating the phase of the light in each of the substituent groups of an optically active molecule by the phase at its own electronic centre of gravity. He found, however, that the dominant contribution to the rotatory power, arising from the interaction of optically anisotropic substituents, had been previously overlooked. Contributions arising from the change in phase of the light in the interior of substituent groups were treated in the one-electron theory of Condon, Altar, and Eyring (ibid. 1937, 5, 753; see also Kauzmann, Walter, and Eyring, Chem. Rev. 1947, 26, 339). In this theory, a chromophoric electron is found to contribute to the rotatory power as the result of dissymmetric perturbations from neighbouring groups in the molecule.

In the molecular theory, the specific rotation  $M$  for light of wave-length  $\lambda_0$  is related to a molecular rotatory parameter  $g$  of the substance by the formula

$$[\alpha] = (2.88 \times 10^4) (w^2 N_A / B M \lambda_0^2) (n^2 + 2)$$

where  $M$  is the molecular weight and  $n$  the mean refractive index of the solution or liquid in which the measurement is carried out, and  $AT$  is Avogadro's number. The rotatory parameter  $g$  is related to the molecular spectrum in the following manner:

$$g = \sum \frac{f_{ab}}{J_{ab}^2} (\nu_{ab}^2 - \nu^2)$$

where the  $\nu_{ab}$  are the absorption frequencies of the ground electronic state of the molecule, and  $\nu$  is the frequency of the incident light, the sum extending over all excited states. In the neighbourhood of an absorption band contributing to optical activity, anomalous rotatory dispersion and circular dichroism (selective absorption of right- and left-circularly polarised light) are observed. The quantities  $g_M$  are proportional to the difference of the absorption coefficients for right- and left-circularly polarised light. According to the quantum mechanical theory of the rotatory power, the imaginary part of the polarisability tensor  $\epsilon_{ij}$  is equal to the imaginary part of the matrix elements of the electric and magnetic moments of the molecule associated with the electronic transition corresponding to the absorption frequency  $J_{ab}$ . Although calculations based on the molecular theory of optical activity yield rotations of the right order of magnitude for simple molecules, the molecular rotatory parameter is very sensitive to the distribution of the molecules among the configurations allowed to them by internal rotation around single bonds. Further applications of the theory and its determination of absolute configurations therefore require more precise structural information than is at present available.

J. G. K.  
OPTOCHIN (v. Vol. III, 1666, 1686).

**ORANGE.** The fruit of *Citrus sinensis* or *C. aurantium* var. *sinensis* (the sweet orange). The bitter variety is usually classified as *C. aurantium*. The orange, originally of southern Asiatic origin, has long been grown in Mediterranean countries, from which its culture spread to many tropical and subtropical areas of America and Africa. The bitter varieties are largely utilised in making marmalade, as also are certain seedless types, notably the "navel" orange. In late years preserved orange juice as a source of vitamin-C and as a "soft" drink has become an increasingly popular commercial commodity. The separated peel may be "candied" and used in confectionery or utilised for the manufacture of orange oil.

For transport or storage the full-grown fruit is picked in the green stage and its coloration accelerated, if required, by exposure to ethylene. Suitable conditions for treatment are described by, among others, R. G. Salcedo (Ciencia, 1942, 3, 165) as 0.2% ethylene, at 18-20°, in an atmosphere of 75% humidity.

Of the total weight of the fruit the peel constitutes 16-40%, the pulp 20-40%, the seed 1-3% according to variety, and approximately one-third of the whole weight is juice.

According to Serger (Chem.-Ztg. 1917, 41, 517) the percentage composition of the parts of the orange is as follows:

	Water.	Protein.	Fat.	Nitrogen-free extract.	Fibre.	Ash.
Peel . . .	68.3	1.5	0.6	12.7	1.40	1.3
Pulp . . .	68.3	1.9	0.2	10.3	7.75	1.5
Seed . . .	11.6	14.4	200	25.8	250	3.2

Among numerous published percentage analyses of orange juice the following are typical:

	Solids.	Citric acid.	Total sugars.	Sucrose.	Reducing sugars.
California:					
Navel . . .	10.7-11.2	0.7-1.7	8.0-13.1	3.2-4.1	
Blood . . .	11.9-15.4	1.0-2.0	8.8-13.0	4.2-5.9	
Sicilian:					
Sweet . . .	9.4-13.3	1.8-2.6			22.0-27.0
Bitter . . .	0.3-11.9	2.4-6.2			0.8-1.9

The principal acids of the juice are citric and malic. These exist partly in free and partly in combined forms, the proportions of which change somewhat during the maturation of the fruit and are related to the concomitant changes in the pH of the juice. According to W. B. Sinclair *et al.* (Bot. Gaz. 1944, 106, 140), the total amount of free acid in developing oranges reaches maximum fairly early in the season and subsequently remains substantially constant. The concentration of free acid, however, diminishes with advancing growth, the increase in pH of

the juice being related to the diminution in concentration of citric rather than of malic acid. In a later paper (Plant Physiol. 1945, 20, 3) Sinclair notes that the amount of combined acid in the fruit remains practically uniform and establishes that the ratio: total free/total free + combined acid is inversely related to the pH. It is usually stated that at maturity the pH of the juice should be 3-65.

Both invert sugar and sucrose occur in orange juice, the proportions of both increasing during the ripening of the fruit (*cf.* Scurti and de Plato, Staz. spec. agric. ital. 1908, 41, 433).

A small amount of inositol (0.0047%) in orange juice is recorded by Nelson and Keenan (Science, 1933, 77, 561).

Odoriferous constituents of orange juice examined by Hall and Wilson (J. Amer. Chem. Soc. 1925, 47, 2575) include ethanol, acetone, acetaldehyde, formic acid, an olefinic alcohol (C<sub>10</sub>H<sub>18</sub>O), isoamyl, and phenylethyl alcohols, esters of formic, acetic, and caprylic acid, geraniol, and terpineol.

Orange seeds contain 10-15% (dry matter) protein from which Saunders (*ibid.* 1931, 68, 696) isolated a crystalline globulin (N=16-8-17-1%) and also up to 40% of a fatty oil. Published characteristics of orange-seed oil include: p<sub>15</sub> 0-920-0-926, n<sub>D</sub> 1\*4643-1-4702, sap. value 192-7-229-0, iodine value 87-5-105-3, Reichert-Meissl value 0-71, Polenske value 0-40, Hehner no. 95-0-95-6.

The fat occurring in small amounts in the pulp of the fruit is shown by M. B. Matlock (J. Org. Chem. 1940, 5, 504) to contain oleic, linoleic, linolenic, palmitic, and stearic acids together with a C<sub>an</sub> (? cerotic) acid. Part of the fatty acids are combined with sterols, notably phytosterol and sitosterol. The proportion of glyceryl esters is relatively low. Fatty matter of similar composition occurs in the peel although this is characterised by the presence of ceryl alcohol (not in pulp fat) and by absence of pentacosane (present in pulp fat).

The volatile oil of orange peel (*v.* Vol. VIII, 659d) is recorded by Hood (J. Ind. Eng. Chem. 1916, 8, 709) to constitute 0-15-0-53% of the total weight of Florida fruit and by Wilson and Young (*ibid.* 1917, 9, 959) as 0-70-1-29% in Valencia varieties.

The *piel* also contains the glucoside hesperidin (2 mol. units of hesperitin combined with 2 mols. of glucose and 1 mol. of rhamnose).

The white inner layer (albedo) of the peel yields approximately 10% of pectin (Ehrlich and Kosmofly, Biochem. Z. 1929, 212, 162). Norris (Biochem. J. 1926, 30, 993) describes the pectic matter occurring in orange juice as a trimethylated derivative of pectic acid.

The pigments in orange peel include chlorophyll, carotene, and several xanthine derivatives. E. V. Miller *et al.* (J. Agric. Res. 1940, 60, 259) establish that, during ripening, carotenoid pigments increase in proportion and that of chlorophyll diminishes. In mature but still green fruit xanthophyll predominates, but in ripe fruit the cryptoxanthin-carotene group of pigments are present in relatively greater amounts. It is also noted that in artificial ripening with ethylene, the treatment stimulates the decomposition of

chlorophyll without affecting the carotenoids. In another publication Miller *et al.* (U.S. Dept. Agric. Tech. Bull. 1941, i No. 780) record an examination of the carotenoids in orange juice.

A gum, occasionally reported in orange peel, is associated by A. R. G. Haas (Plant Physiol. 1945, 20, 323) with a deficiency of boron in the tree.

A large part of the dietary value of oranges depends on their richness in vitamin-C. Richardson *et al.* (Food Res. 1937, 2, 81) gives the average ascorbic acid content per fruit as 20-30 mg. O. D. Atkins *et al.* (Fruit Prod. J. 1945, 24, 26) gives the value 106 mg. per 100 g. of fruit; 75% of this is present in the peel and "rag" and 25% in the juice. Canned orange juice retains 95% and upwards of its vitamin-C and even when cans are stored at 21° the further loss corresponds to only about 1% per month (F. C. Lamb, Ind. Eng. Chem. 1946, 88, 360). A dried, powdered; orange peel containing 240-366 mg. of ascorbic acid per 100 g. is described by J.H. M. Rauen *et al.* (Z. Unters. Lebensm. 19\*3, 85, 257). *Tin.* the preparation of marmalade from bitter oranges it is said to be possible to ensure the retention of 65% of the vitamin, although commercial products frequently contain only one-third or less of this amount. "

Oranges contain an average of 0-5% of ash constituents of which the following data are typical: K<sub>2</sub>O 48-50, Na<sub>2</sub>O 3-4, CaO 22-24, MgO 4-5-5-5, Fe<sub>2</sub>O<sub>3</sub> 0-6-0-9, Mn<sub>2</sub>O<sub>3</sub> 0-4-0-6, P<sub>2</sub>O<sub>5</sub> 8-5-13-0, SO<sub>3</sub> 4-4-5-1, SiO<sub>2</sub> 0-8-1-1, Cl 0-9-1-1%. Among "trace" elements examined are Al 0-88, Cu 0-8, Zn 1-7, As 0-1, B 50. Fig. per kg. of fresh-fruit.

A. G. Po.

**ORANGE ' FLOWERS, OIL OF v. NBKOLI (Vol. VIII, 461c).**

**ORANGE LEAVES, OIL OF v. NBBOLI (Vol. VIII, 461c).**

ORANGE, PALATINE, is the ammonium salt of tetranitro-4:4'-dihydroxydiphenyl, which is obtained by the action of fuming nitric acid on 4:4'-diphenol or on benzidine. Palatine orange was in use as a dyestuff, giving orange shades on silk or wool, but is no longer manufactured.

J. N. G.

ORANGE, SALICYLIC, a dyestuff now obsolete, prepared by successive nitration and bromination of salicylsulphonic acid,



It dyes orange shades on silk and wool.

J. N. G.

ORANGITE. An orange-coloured variety of the mineral thorite (*q.v.*), occurring as tetragonal crystals and irregular masses, occasionally a few ounces in weight, in the augite-syenite of southern Norway. It was described and named by C. Bergemann in 1851, and believed by him to contain a new element "donarium." The identity of the mineral with thorite has long been recognised.

L. J. S.

**ORBITALS, ELECTRONIC v. VALENCY.**

ORCEIN v. PHENOL AND HOMOLOGUES (this Vol., p. 466d).

ORCHIL v. LICHEN-SUBSTANCES (Vol. VII, p. 2Ud).

ORCIN v. PITENUL AND HOMOLOGTJES (NOB Vol., p. 46&Z).

ORCINOL v. PHENOL AND HOMOLOGUES (this Vol., p. 466d!).

ORDEAL BEAN v. CALABAR BEAN (Vol. II, 198d).

ORDER-DISORDER TRANSFORMATIONS IN ALLOYS. Broadly speaking, the distinction between organic and inorganic chemistry arises from the ability of carbon atoms to unite together to form definite molecules. Such a molecule as that of benzene,  $C_6H_6$ , can be observed by means of X-rays as a real entity existing as either solid, liquid, or gas, and preserving its distinctive nature throughout the changes of state. The crystal symmetry is dictated by the molecule itself. In the realm of inorganic chemistry the term molecule becomes a mere conception and no longer corresponds to a real physical entity. On the borderline, carbon dioxide has a molecule,  $CO_2$ , though, in the solid, X-ray evidence shows that the substance consists not of isolated molecules, but of a continuous structure in which the linkage between carbon and oxygen is only a little more important than the cohesion between oxygen and oxygen which is responsible for holding the whole structure together. »

For the chemistry of the non-metals, the conception of the molecule is thus perfectly valid for the liquid and gaseous states, and partly valid for the solid state. For the chemistry of the metals the whole conception of molecules must be abandoned, since here an atom is linked not to one neighbour, as the formula  $NaCl$  formerly suggested, but to the whole of its nearest neighbours. Thus in sodium chloride each sodium and each chlorine atom has six nearest neighbours of the opposite kind. In calcium chloride each atom has eight nearest neighbours of the opposite kind. The law of constant proportions is still valid, but for a different reason. In the non-metallic compounds its validity depended on the real presence of the molecule. In the metallic compound it depends only on the presence of ions with unitary charges. Thus calcium fluoride is a compound of definite composition because every calcium atom bears two positive charges, and every fluorine atom bears one negative charge. For this reason every calcium atom is surrounded by eight fluorine atoms, but a fluorine atom is only surrounded by four calcium atoms. This ratio is a mathematical necessity, and the law of constant proportions results.

A new kind of chemistry must be studied when the fields of metallurgy are explored. Here evidence for the existence of molecules is rarely, if ever, found. When then should it be expected that the law of constant proportions is obeyed unless there are either definite bonds, as in the carbon compounds, or unitary ionic charges to compel its observance? The answer lies in the requirements of space. Each atom occupies so much space, a big atom taking up more room than a smaller atom. The atom of caesium is ten times larger, whereas that of carbon is very small. In between we have a wide range of size. The

problem of metallurgy is to find out what happens when atoms of different sizes are mixed.

If two metals, of which the atoms are of different sizes, are mixed, there are only two possibilities; either the large and small atoms are distributed in a purely random fashion, in which case the atomic planes will be warped and twisted, or alternatively there may be a regular alternation of sites of different sizes, big and little, so that the atomic planes will be preserved in their pristine regularity. In the former case a solid solution is found, in the latter a superlattice. The ideal superlattice would correspond to a definite composition and would obey the laws of definite and multiple proportions. It may, therefore, be regarded as a compound, but normally speaking this is not justified, for reasons which will be discussed at a later stage.

Types of Superlattice in Face-centred and Body-centred Cubic Lattices.—Figs. 1 (a), (b), and (c) show the types of superlattice which occur in face-centred and body-centred cubic alloys. The face-centred cubic alloys can form only one kind of superlattice; examples are  $Cu_3Au$  (formed when copper-gold solid solutions are slowly cooled, provided the composition does not depart too much from the theoretical value),  $Ni_3Fe$ , and  $Ni_3Mn$  (Fig. 1 (a)).

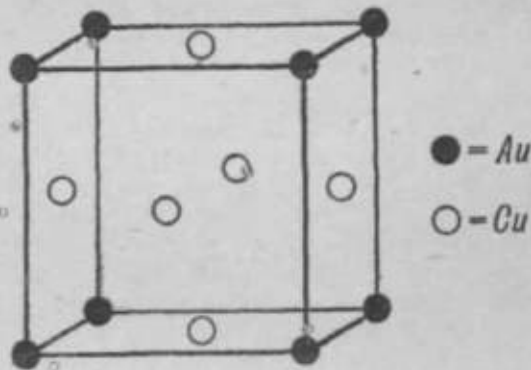

FIG. 1 (a).

Body-centred cubic alloys form two kinds of superlattice. In the simpler kind the proportions of the two constituents are roughly equal, as in Fig. 1 (b). In the other they are nearer

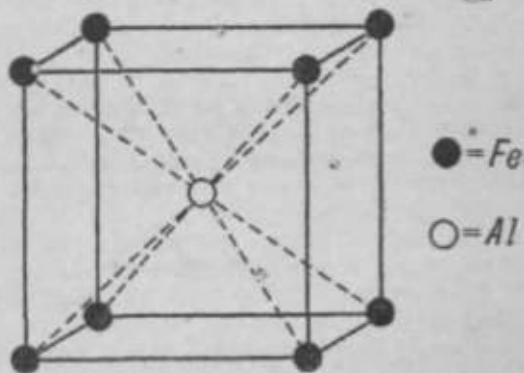

FIG. 1 (b).

three to one, as in Fig. 1 (c). This has been most fully worked out for the FeAl system, and the results are shown in Fig. 2, in which two kinds

of heat-treatment have been considered, the alloys having been either slowly cooled or quenched from above 600°.

The slowly-cooled alloys alone form structures of the Fe<sub>3</sub>Al type; quenched alloys form the FeAl type of structure. It is interesting to

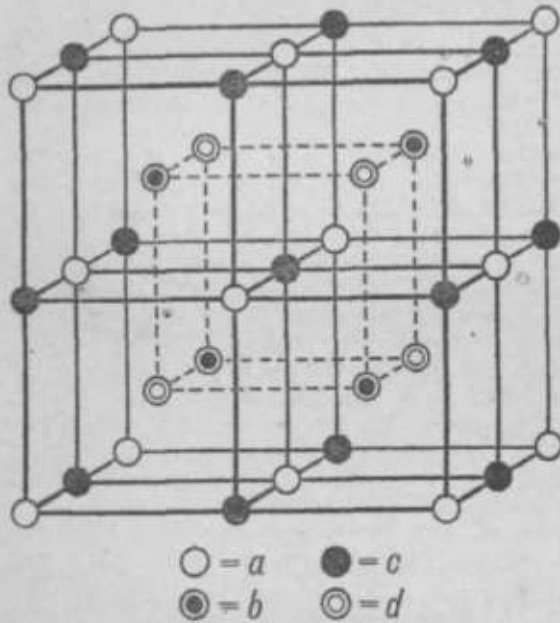

FIG. 1 (c).

notice what happens when the composition deviates widely from the theoretical values. If there are exactly equal numbers of iron and aluminium atoms, the former occupy cube corners, the latter cube centres. With less than 50% of aluminium the atoms at cube corners are still iron atoms, but the atoms at cube

centres now become partly iron and partly aluminium, the distribution being perfectly at random between *b* and *d* positions. When the structure changes over from the FeAl to the Fe<sub>3</sub>Al type by annealing, no change occurs at the cube corners, which remain pure iron, but at cube centres the *b* and *d* atoms also take up a regular arrangement, iron alternating with aluminium in the manner shown in Fig. 1 (c). With more than 25% of aluminium the excess passes over into the neighbouring cube centres. With less than 25% of aluminium the superlattice formation is gradually broken up and the structure soon becomes random.

Remarkable types of superlattice are found in the NiAl system, the lattice spacing curves (a) for which are shown in Fig. 3. The maximum lattice spacing corresponds to the exact composition NiAl. If there is less than 50% of aluminium in this body-centred cubic structure the aluminium atoms, at cube centres are partially replaced by nickel atoms, and because these are smaller the lattice dimensions shrink. On the other hand the lattice will not accept additional aluminium atoms, so that if there are fewer than 60% of nickel atoms present in the alloy, their places are not occupied by aluminium atoms, but gaps are left in the lattice. This causes the lattice dimensions to fall rapidly as the structure departs from the ideal composition. The density curve (f) also shows a decided drop corresponding to the ejection of atoms from the unit cell.

In the ternary system FeNiAl, Fig. 4, the lattice spacing attains a maximum along the FeAl-NiAl, iron and nickel atoms replacing one another in a perfectly random fashion with aluminium always occupying the special positions at cube centres. Excess of either iron or

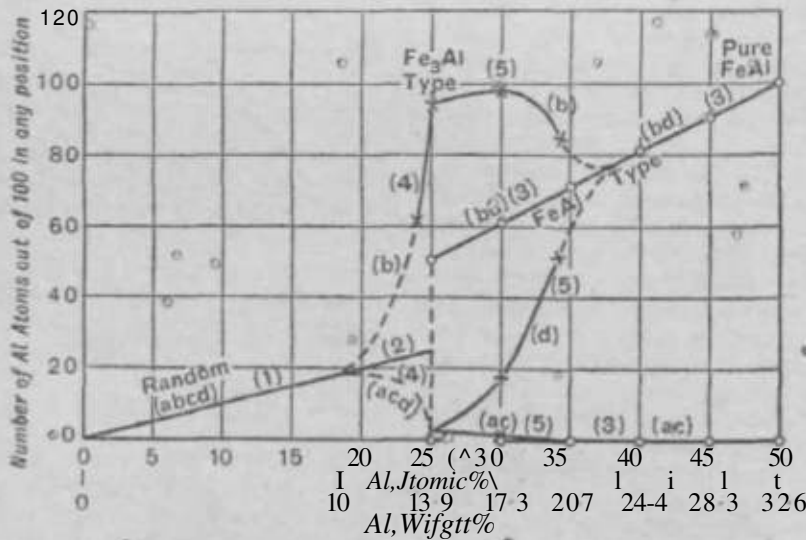

FIG. 2.

niche] replaces aluminium, but a deficit of either element leaves vacancies in the lattice.\*

So far only the formation of superlattices which involve no change of symmetry has been considered. This is the true phenomenon of ordering, and must clearly be distinguished from the formation of a separate phase since there is

apparently no sharp gap between a completely disordered structure with no superlattice, and one in which a superlattice is just beginning to form. Attention must now be turned to another type of structure which is not strictly speaking a superlattice. It will be referred to as a super-structure.



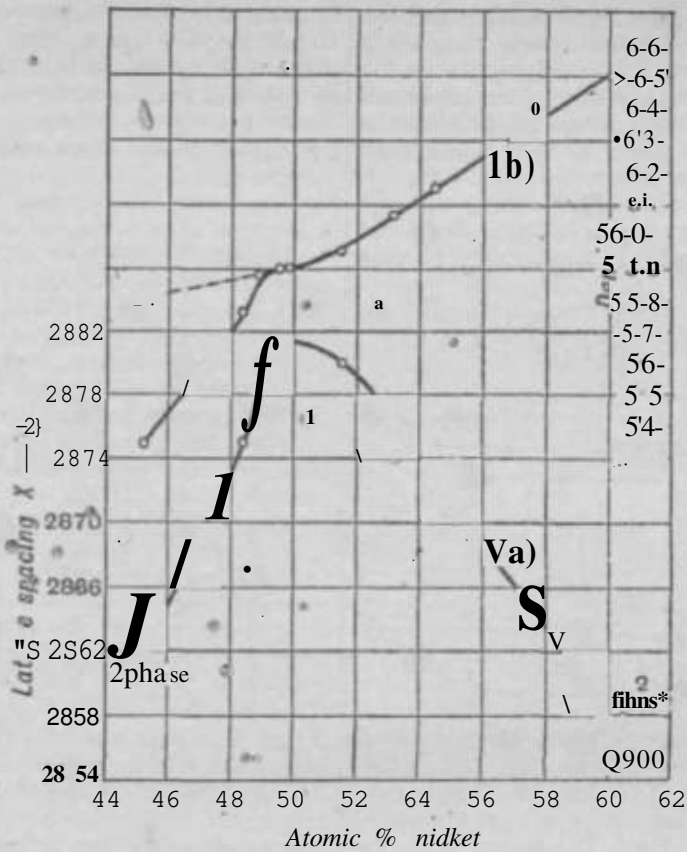

Fig. 3.

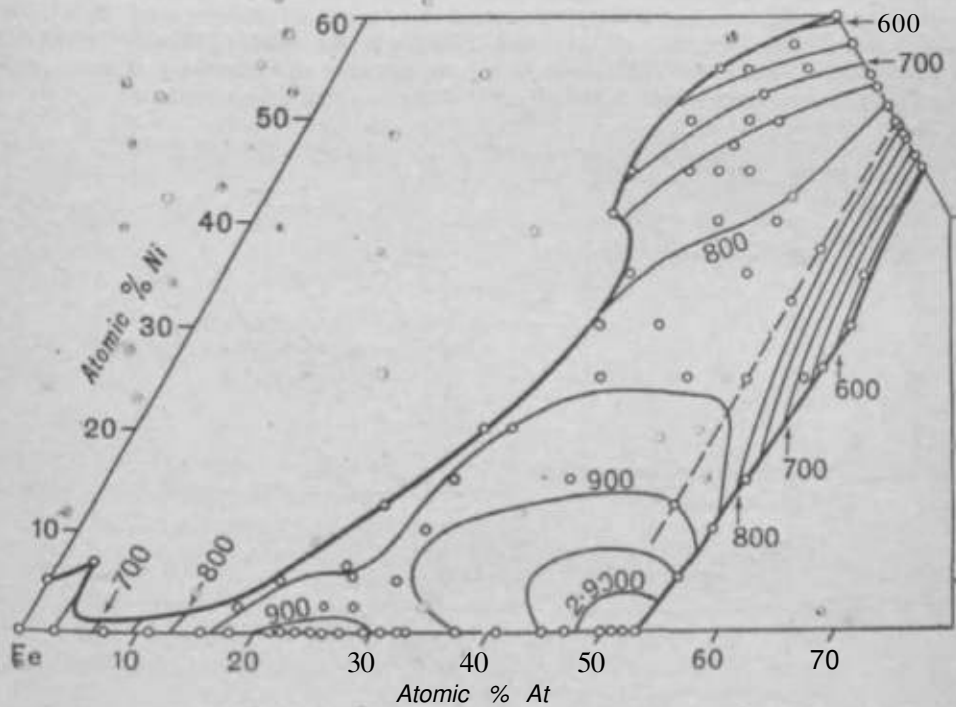

FIG. 4.

The compounds  $\text{CuAu}$ ,  $\text{CuPd}$ ,  $\text{CuPt}$  though obtained from the face-centred cubic lattices by slow cooling, produce an ordered structure by definite change of phase. The first becomes tetragonal (Fig. 5 (a)), the second body-centred cubic like  $\text{FeAl}$ , while the third becomes trigonal (Fig. 6). Under these

conditions it is possible to form ordered structures with 50% of each of the ingredients, which would be impossible if the structures were to remain face-centred cubic. An interesting example of a similar character is to be found in the chromium-aluminium system, in which body-centred cubic alloys form a superstructure

near the composition  $\text{Cr}_t\text{Al}$  in which symmetry is no longer cubic but tetragonal (Fig. 5 (b)). This structure is formed by stacking three cubes vertically one above another. Two planes of chromium alternate with one plane of aluminium atoms, though the atomic sites remain almost the same as in the body-centred cubic state.

The superstructure  $\text{Cr}_t\text{Al}$ , if such it may be called, differs from a superlattice because the symmetry is different. In consequence there is

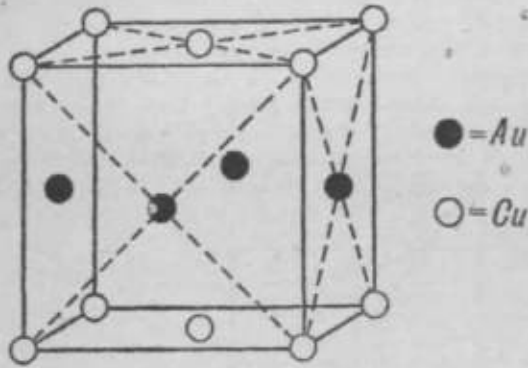

Fig. 5 (a).

a definite temperature at which the tetragonal structure finally breaks down and the random structure is produced. Below this temperature the tetragonal structure is stable over a range of compositions; the lower the temperature the greater the range of stability. On either side, beyond the range of homogeneous composition, there is a two-phase region in which the structure is present in admixture with one of the neighbouring phases. An important point to note is that the composition corresponding to the precise

formula  $\text{Cr}_2\text{Al}$  does not correspond to the point of maximum stability, neither does this composition lie within the homogeneity range as far as this has been determined. The structure is therefore a separate phase, but is neither a true compound nor a superlattice. It is for this

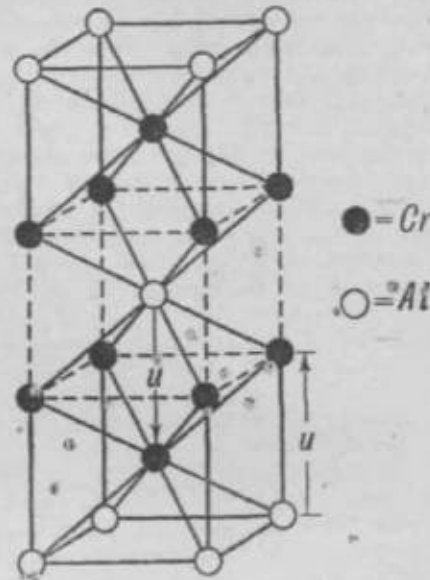

Fig. 5 (b).

reason that it has been termed a superstructure. There are, however, genuine superlattices which behave in much the same manner, e.g.,  $\text{Ni}_3\text{Al}$  has a range of stability which increases with falling temperature. It includes the theoretical composition and is separate from neighbouring phases by two-phase regions.

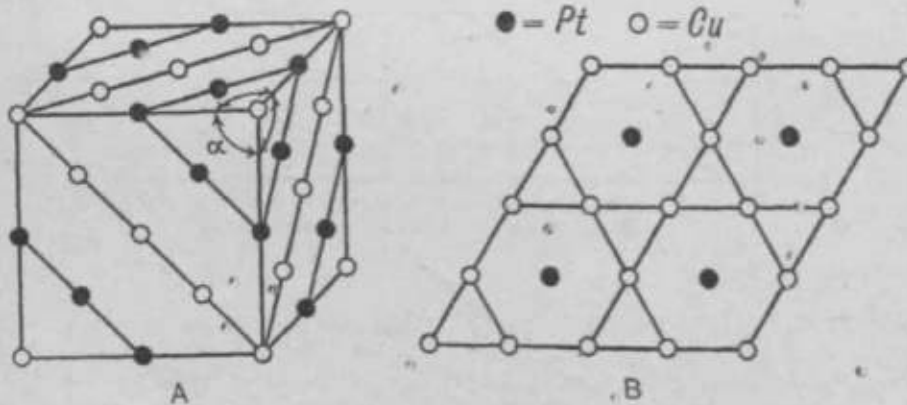

Fig. 6.

Other superlattices, e.g.,  $\text{Cu}_3\text{Au}$ , do not appear to be separated by two-phase regions; they should, therefore, not be regarded as separate phases, and some metallurgists consider that they should not be included in the equilibrium diagram. In this type of structure there is a gradual change from the ordered state to the disordered state as the composition changes and as the temperature is raised. The various theories of order-disorder have been evolved to explain this type of superlattice. The first satisfactory treatment was given by Bragg and Williams.<sup>81 B</sup> The essential feature of their

theory is that all the atoms lie at specific points on a three-dimensional space-lattice. Each of these points is a site for atoms, the problem being which sites are to be occupied by what kind of atoms. The theory of probability is invoked to provide a solution, but certain *ad hoc* assumptions have to be made which account for the fact that the theory does not give an exact quantitative agreement with the facts.

By making entirely different assumptions based upon the relationship of atoms to their nearest neighbours Bethe<sup>10</sup> has obtained somewhat different numerical values for the physical



constants first determined by Bragg and Williams, but, as Peierls<sup>4</sup> has shown, it is too difficult to make precise numerical calculations for the face-centred cubic lattice by this means. In spite of work by other investigators, the problem still awaits an exact treatment. It is, however, very interesting to compare the experimental facts, especially those obtained by Sykes<sup>12</sup> and his collaborators with the theoretical calculations made by different methods.

The physical symptom produced by the warped planes of a solid solution is a great increase in electrical resistivity. The formation of a superlattice, because it flattens out the atomic planes, leads to a tremendous decrease in the resistance offered to the passage of electricity through the crystal. It is as though the electrons were sliding through the channels

between the atomic planes; where the channel is blocked the electron is brought to a halt; where there is a clear passage the electron goes through without hindrance.

The electrical resistivity curve for  $Cu_3Au$  has been plotted by Sykes and Evans<sup>13</sup> (Fig. 7). The quenched alloy, which is in a disordered state, has a high resistivity at all temperatures. On annealing below the critical temperature the resistivity rapidly falls owing to the formation of the superlattice. The relation between the resistivity of the annealed and quenched alloys gives a measure of the degree of order.

Another property which changes during the ordering process is the specific heat, which has been extensively studied by Sykes and Jones.<sup>14</sup> Fig. 8 shows the variation of specific heat with temperature. The curve indicated by full circles

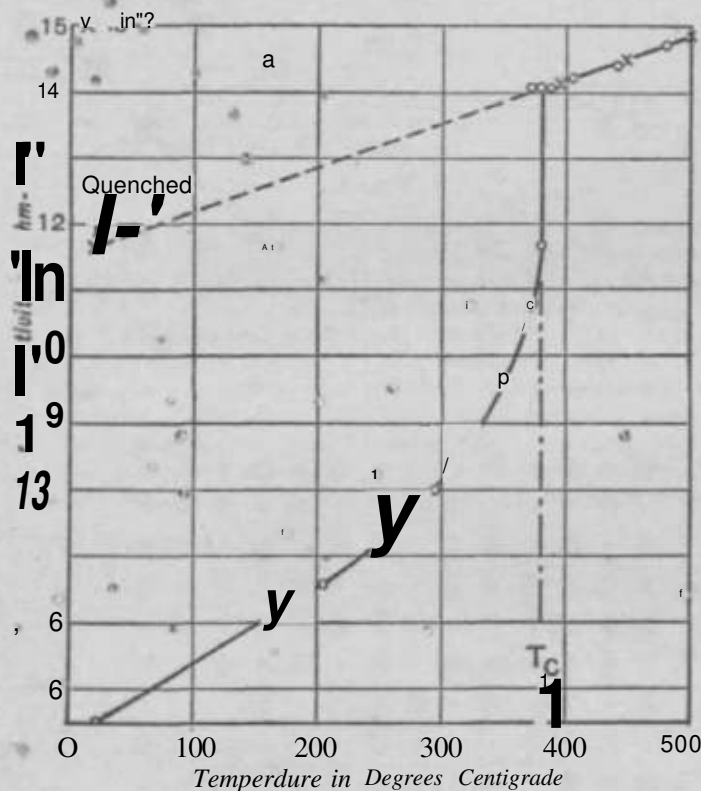

FIG. 7.

The degree of order gradually falls in the range below the critical temperature. Above the critical temperature what order is left is of a different kind. The distinction can be made clear in the following way: a series of lattice points along a given row may be arbitrarily designated as even and odd. If all the odd atoms are copper, and all the even are gold, the alloy is perfectly ordered. In a partly ordered alloy some of the copper atoms have got into the even positions, and some of the gold atoms into the odd positions. Now suppose that there is a purely random distribution in which there are just as many copper atoms in odd as in even positions. Of course, the same will apply to the gold atoms. This is the case above the critical temperature, and the change which occurs between 225° and 319° is that the atoms more and more assume the disordered state, so

The degree of order gradually falls in the range below the critical temperature. Above the critical temperature what order is left is of a different kind. The distinction can be made clear in the following way: a series of lattice points along a given row may be arbitrarily designated as even and odd. If all the odd atoms are copper, and all the even are gold, the alloy is perfectly ordered. In a partly ordered alloy some of the copper atoms have got into the even positions, and some of the gold atoms into the odd positions. Now suppose that there is a purely random distribution in which there are just as many copper atoms in odd as in even positions. Of course, the same will apply to the gold atoms. This is the case above the critical temperature, and the change which occurs between 225° and 319° is that the atoms more and more assume the disordered state, so

producing the observed heat evolution. Now consider what happens above the critical temperature. It is true that there are as many copper atoms in odd as in even positions, but the sequence of copper and gold atoms if all the time being changed. There are little groups of atoms

in which copper and gold alternate, but every now and again the sequence is interrupted BO that (ve get, e.g., Cu Au Go Au Cu Cu Au Cu Au Cu Au Au Cu Au Cu Au. These short bursts of order kitown as local order are gradually dispelled as the temperature rises, which requires

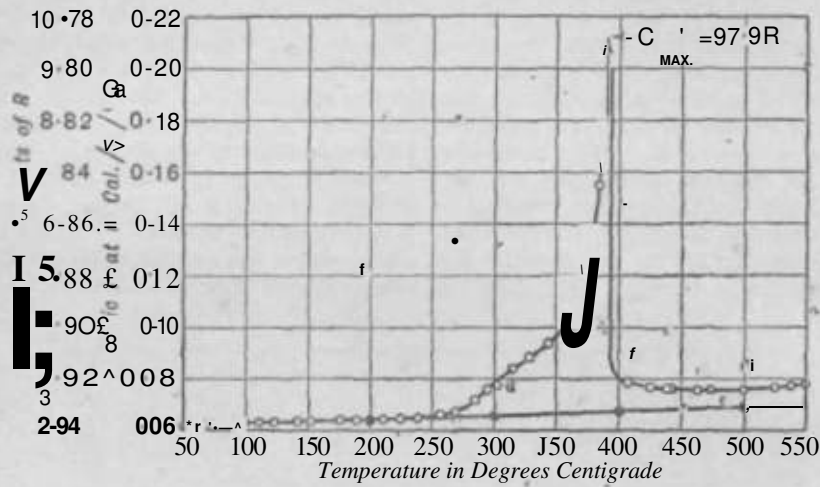

FIG. 8.

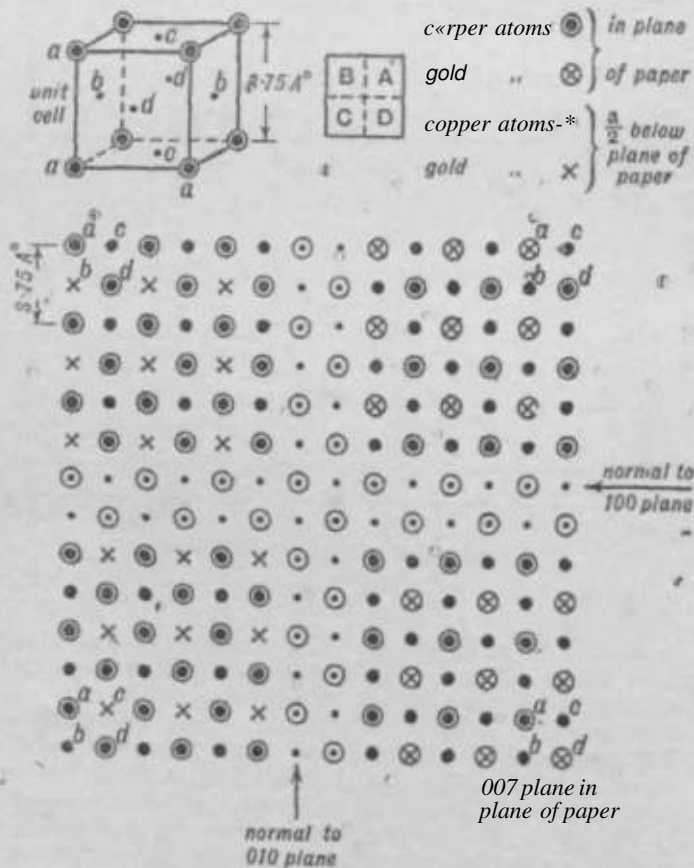
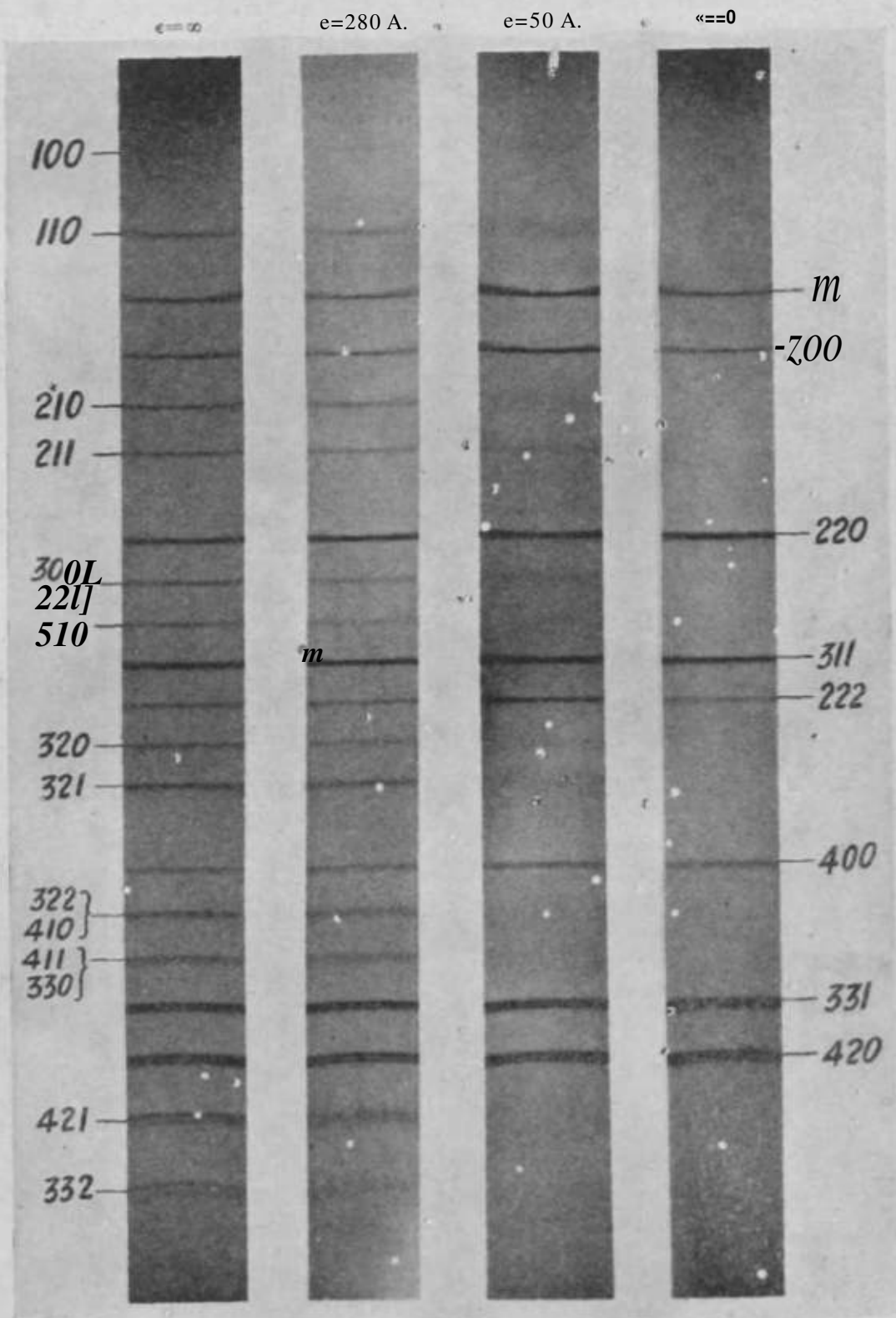

FIG. 9.

the absorption of more energy, and produces the additional specific heat.

Now consider what happens on cooling an alloy through the critical temperature. Immediately this temperature is passed the short borste of order instantaneously produced at the higher temperatures each act as nuclei for a

completely ordered system. In such a aeries as Cu Au Co>Au {Au Cu} Cu Au Cu Au Cu Au the out-of-step atoms shown in parentheses get changed round to the normal state of their neighbours, and the ordered region extends. When the nuclei attain a certain size they become stable, but they do not all face the same



FLO. 10.—POWDER PHOTOBAPHS of  $\text{Cu}_a\text{Au}$ .  
 «=Siz6 of anti-phase nviolei.  
 (From Jones and Sykes, Proc. Roy. Soc.<sup>1</sup>, 1938, A, 166, Plate 1ft.)

way round and, at the point of contact between the different schemes of order, a struggle takes place to decide which scheme shall triumph (Fig. 5). For this reason there is amorphous material in the grain boundaries between the portions with different schemes of order.

The origin of the differences is that the face-centred cube is built up from four independent simple cubic lattices, any one of which may be regarded as forming the corners of the unit cell. The other three will, in that case, correspond to the centres of cube faces. It is, therefore, arbitrary which of the four lattices is to be occupied by gold, but once this has been decided the remaining three must be copper. The original nuclei from which the ordered structure was to be built up constitute anti-phase nuclei,

because there is no necessity for them to conform to the decisions of the other nuclei. Once these anti-phase nuclei are formed they are extraordinarily stable.

The process of ordering below the critical temperature therefore consists of the formation and growth of the anti-phase nuclei.<sup>16</sup> If the nuclei are small they produce broadened lines on the X-ray photographs due to the superlattice, though the main lines are sharp, because the lattice as a whole retains its original alignment irrespective of whether the atoms are ordered or disordered (Fig. 10). In order to produce an increase in the size of the nuclei it is necessary to heat-treat the alloy just below the critical temperature. If the alloy is cooled before nuclei have grown, the degree of order

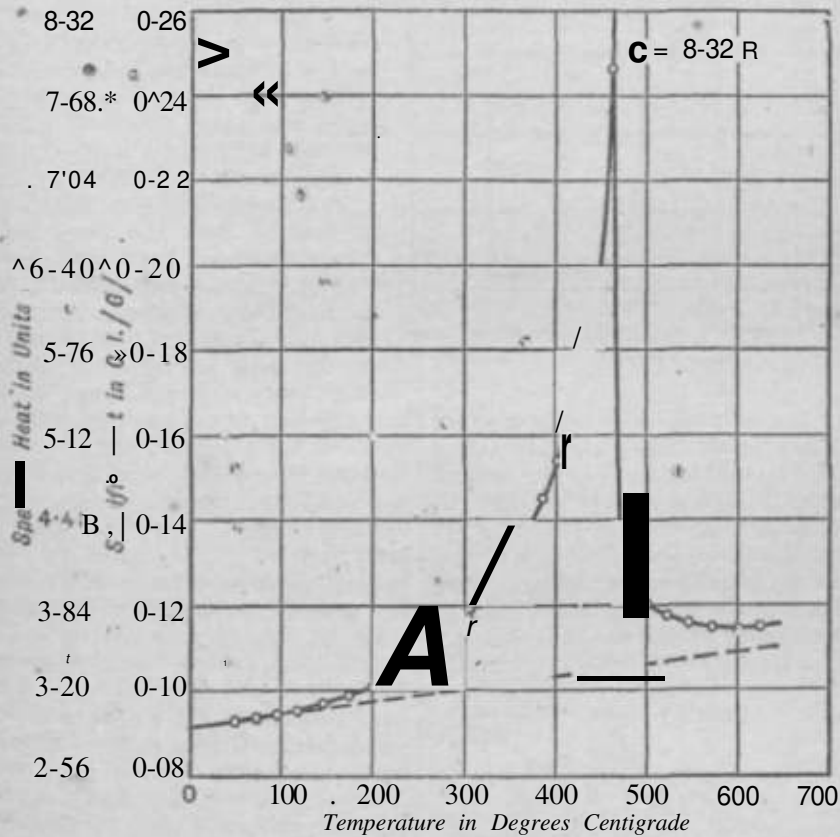

FIG. 11.

gradually rises, even at lower temperatures. The critical temperature is about  $6 \times 10^7$  cm., below which the material is disordered. The critical resistivity does not fall until the nuclei have grown inside the amorphous material. In the size of the nucleus or by an increase in the degree of order each nucleus. On the other hand, the ordering process can be observed on photograph. This evidence is very important as show-

ing that the lattice spacing is not a constant depending on the type of structure and its composition, but it depends on the exact way in which the atoms are fitted together in respect to one another. In this connection it is of interest to compare the behaviour of Ni<sub>3</sub>Al, the lattice spacing of which varies as much as 1% according to the temperature from which the alloy is quenched, in spite of the fact that it is always ordered. Enough has been said to show the complicated nature of the order-disorder process for the face-centred cubic alloys.

A simpler case for comparison of theory with experiment is that of CuZn alloy, the approximate formula for which is CuZn (Fig. 1(a)). The specific heat-temperature curve for an alloy containing 48.9% of zinc is shown in Fig. 11 (due to Moser<sup>15</sup>). It shows the same general

features as the case of Cu-Au, but here there is no complication due to the formation of anti-phase nuclei. A more detailed curve due to Sykes<sup>11</sup> is shown alongside (Fig. 12). It must be stated at once that it is impossible to explain the details of these curves by any existing theory, though their general features are satisfactorily explained by all.

As the best known example reference will be made to the Bragg-Williams<sup>12</sup> theory in more

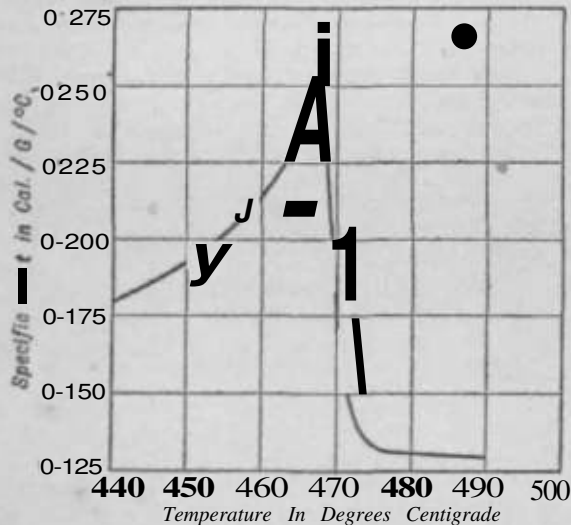

FIG. 12.

detail. The essential point is that there are  $n_A$  and  $n_B$  sites in the crystal. In a state of complete order all  $n_A$  sites are occupied by A atoms, and all  $n_B$  sites by B atoms. It is enough to consider the A atoms, as the positions of the B atoms are thereby fixed. There is a certain probability that a given A atom will be in a right or wrong position. This depends not only on the number of available positions but also on the Boltzmann factor,  $e^{-E/kT}$  corresponding to the extra energy

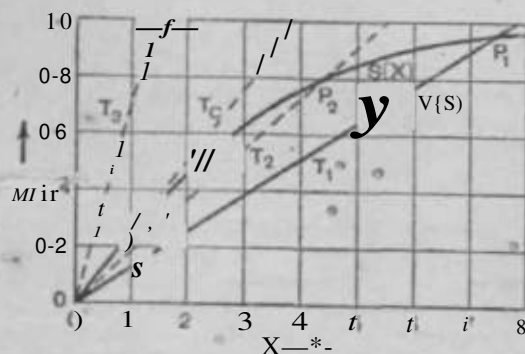

FIG. 13.

$V$  which is required to put an A atom in a wrong position. The tendency for an atom to get out of a right position into a wrong position, therefore, depends on a chance factor which is not affected by temperature, and an energy factor which is. As soon as the energy factor becomes small enough the chance or entropy factor overtakes it and the alloy becomes disordered. This gives a qualitative explanation of the occurrence of a critical temperature.

The gradual change from order to disorder may be interpreted in this way: the more the alloy becomes disordered, the more difficult it is for an atom to find the right position, since in a state of complete disorder it is impossible to say which is a right and which is a wrong position.

Fig. 13 shows two curves connecting the energy relations with the degree of order at a given temperature  $T$ .  $V(S)$  gives the dependence of ordering energy on order, while  $S(X)$  allows for the Boltzmann factor. At equilibrium the degree of order is indicated by the point of intersection of the two curves. For different temperatures there is a family of  $V(S)$  curves, so that the point of intersection shifts with rising temperature. For the critical temperature  $T_6$  the  $V(S)$  curve is tangential to the  $S(X)$  curve at  $X=4$ . The alloy is then completely disordered. As the temperature falls the point of intersection with the  $S(X)$  curves moves to the right, and since ultimately the  $S(X)$  curve becomes asymptotic to  $X=1$ , the alloy becomes completely ordered.

The Bragg-Williams equations may also be derived from the free-energy principle, which method has also been used by Fowler.<sup>18</sup> These methods consider the lattice as a whole, whereas Bosthe<sup>10</sup> and also Peierls<sup>19</sup> think of the atoms individually, but confine their attention exclusively to nearest neighbours, whereas Chang<sup>15</sup> has extended the investigation to the next nearest atoms. Kirkwood<sup>20</sup> has also used the free-energy method. Borelius<sup>21</sup> and Dehlinger and Graf<sup>22</sup> were the first to advance theories on the subjects of order-disorder change, the gold-copper system having been very fully investigated by Johansson and Linde.<sup>5</sup> The importance of the size factor was first pointed out by Pume-Rothery.<sup>23</sup>

Recognition of superlattices has led to much experimental work. Originally predicted by Tamman<sup>24</sup> and observed by Bain<sup>25</sup> for  $\text{Cu}_3\text{Au}$ , by Phragmen<sup>26</sup> for  $\text{Fe}_3\text{Si}$ , and by Johansson and Linde for  $\text{CuAu}$ , superlattices have in more recent years been detected by other means than X-rays. Fallot<sup>27</sup> has found a superlattice of the composition  $\text{Ni}_3\text{Mn}$  by means of magnetic measurements. The superlattice of  $\text{CuZn}$ , first investigated by specific heat measurements, has been confirmed by Jones and Sykes<sup>28</sup> using X-rays.

The method employed was that previously used by Bradley and Rogers<sup>29</sup> for the investigation of  $\text{Cu}_3\text{MnAl}$ . The copper atoms are at cube corners, the manganese and aluminium at alternate cube-centres, so that the structure is essentially like that of  $\text{Fe}_3\text{Al}$ . It was elucidated with the help of X-rays of various wave-lengths to alter the relative values of the scattering powers of the atoms. Ordinarily the scattering powers of copper and manganese (atomic numbers 26 and 25) are too nearly equal to show any contrast. This is especially so with zinc radiation, which depresses the scattering power of copper. On the other hand, the scattering power of manganese is depressed by using iron radiation, so that this emphasises the contrast between copper and manganese.



Sykes and Jones investigated CuAu (atomic numbers 29 and 30) by using zinc radiation to depress the scattering\* power of copper. Sykes and Leech also found a superlattice in Ni<sub>3</sub>Fe<sup>30</sup> (atomic numbers 28 and 26) for the first time by using cobalt radiation to depress the scattering power of iron. The general rule is that if N is the smaller atomic number, X-rays are obtained from d target with atomic number (#+1), and this method may be applied over a considerable range of elements.

References.

A. J. Brauer and A. H. Jay, Proc. Roy. Soc. 1932, 118B, 212.  
 H. L. Taylor and A. Taylor, Proc. Roy. Soc. 1939, A, 173, 232.  
 C. F. Bohannan and J. C. Lindner, J. Chem. Phys. 1937, 5, 449.  
 A. J. Bradley and S. S. ITI, Z. Krist. 1937, 96, 20.  
 W. A. W. Williams, Proc. Roy. Soc. 1935, A, 152, 231.  
 Y. Ulam, J. Phys. 1935, A, 150, 552.  
 G. B. B. B., J. Chem. Phys. 1936, A, 154, 207.  
 H. A. Kit, 1935, A, 148, 422.  
 S. A. and H. Evans, J. Inst. Metals, 1936, 58, 255.  
 S. A. and F. W. Jones, ibid. 1936, 59, 257.  
 A. S. C., 1936, 213.  
 H. A., Physikal. Z. 1936, 37, 737.  
 H. A., J. Inst. Metals, 1937, 61, 223.  
 H. A., "Statistical Mechanics," 2nd ed., Cambridge University Press, 1936.  
 J. P. J., Proc. Roy. Soc. 1937, A, 161, 546.  
 J. C., J. Chem. Phys. 1938, 6, 70.  
 H. A., Ann. Physik, 1934, 10, 57.  
 H. A., Mite, 1934, 291.  
 X. J. P. J. and a., Z. Physik, 1930, 64, 359.  
 G. T. K., Kothery and H. M. Powell, Z. Krist. 1935, 91, 23.  
 B. C., Z. Physik, 1919, 107, 1.  
 G. K. P., Met. Mag. 1923, 28, 65.  
 S. M. I., Ann. Physique, 1936, [iv], 6, 305.  
 F. W. T., Proc. Roy. Soc. 1937, A, 144, 34b.  
 J. Bradley and J. J. T. Rodgera, iWd. 1934, A, 74, 2.  
 P. I. Aech and C. Sykes, Phil. Mag. 1939, [vii], 27,

probably does not occur as such in proteins, but it is obtained by alkaline hydrolysis of various proteins (Kossel and Weiss, Z. physiol. Chem. 1909, 59, 492; 60, 311; 68, 160) probably owing to the degradation of Z-arginine under these conditions; it is also formed by alkaline hydrolysis of citrulline. For the occurrence in other sources, see Winterstein (*ibid.* 1919, 105, 28); Manske (Canad. J. Res. 1937, 15B, 84); Gordon, Martin, and Syge (Biochem. J. 1943, 87, 313).

The preparation from Z-arginine by hydrolysis with alkali is accompanied by racemisation. Optically, pure Z(+)-ornithine may conveniently be prepared by the action of the arginase of mammalian liver on Z-arginine as described by Hunter (*ibid.* 1939, 83, 27). Z-Ornithine is also obtained by the action of arginase on ZZ-arginine, when only the Z-isomer is degraded (Biesser, Z. physiol. Chem. 1906, 49, 210), or by resolution of synthetic dZ-ornithuric acid (Sdrensen, Chem. Zentr. 1905, II, 461).

Z-Ornithine, usually isolated as a syrup, can be obtained crystalline from alcohol-ether, m.p. 140° (softens at 120°), [α]<sup>D</sup> +11.5° (c=6 in water). It is very soluble in water, readily so in alcohol, sparingly so in ether (Vickery and Cook, J. Biol. Chem. 1931, 94, 393). The aqueous solution is strongly alkaline; for the acidic and basic dissociation constants, see Schmidt, Kirk, and Schmidt (*ibid.* 1929, 81, 249).

Jaffé (*l.c.*) showed that ornithine is a diamino-valeric acid. The location of the amino-groups is shown by its degradation to carbon dioxide and putrescine (α8-diamino-w-butane) by putrefactive bacteria (Eunpr, Ber. 1898, 81, 3183). Confirmation of the accepted structure is found in the syntheses of ZZ-ornithine mentioned below. The configurational relationship of the l(+)-acid to Z-arginine and Z-proline has been established by degradative and synthetic methods (Karrer and Ehrenstein, Hely. Chim. Acta, 1923, 9, 323), that to other naturally occurring amino-acids by optical methods (Karrer, *ibid.* 1926, 9, 301; Lutz and Jirgensons, Ber. 1931, 64 [B], 1221).

Nitrous acid in the presence of mineral acid converts ornithine to αS-dihydroxy-n-valeric acid (Schulze and Winterstein, Z. physiol. Chem. 1898, 26, 11); for the rate of deamination under Van Slyke conditions, see Plimmer (chem. J. 1924, 18, 107). By the action of benzoyl chloride and alkali it is converted into ornithuric acid (Fischer, Ber. 1901, 34, 462); interaction with cyanamide gives arginine (Schulze and Winterstein, *ibid.* 1899, 82, 3191; Z. physiol. Chem. 1901, 84, 123). On dry distillation of the hydrochloride pyrrolidine is formed. Ornithine reacts with salicylaldehyde to give an o-hydroxybenzylidene derivative, from which on hydrolysis the amino-acid is regenerated, a reaction useful in isolation procedures (Bergmann and Zervas, *ibid.* 1926, 152, 282).

Some aspects of the intermediary metabolism of Z-ornithine are of importance. In birds it replaces glycine as a means of detoxicating various acids, which are excreted as the N<sup>15</sup>N-β-acetyl derivatives. Thus hens receiving benzoic or β-phenylpropionic acids in their diet excrete

**ORDER OF BONDS & VALENCY.**  
**ORIENTATION AT SURFACES.**  
**ORIGANENE & TRUENEN.**  
**ORIGANUM OILS & ESSENTIAL.**  
**ORMOSINE, ORMOSININE? Isomeric alkaloids extracted from the Venezuelan plant Ofitooaia (Fam. Leguminosa). O? Cosine m.p. 85.175° needles with 3-4H<sub>2</sub>O, m.p. 2033205° (ormosinine) C<sub>20</sub>H<sub>31</sub>MN<sub>3</sub>, prisms. [Bl. 107A] (Hess and Merck, Ber., 1919, 52) For O. species in medicine, see Freise, Tropenplanzer, 1936, 41, 41.**

J. N. G.

Λ firsii of ijff J<sup>OOH</sup> The (- isomer) hydrochloride by the action of benzoic acid on ornithuric acid (Ber. 1926, 1878, 11). Ornithine

Z-ornithuric acid; phenylacetic and  $\alpha$ -furoic acids are excreted as the *m*-phenylacetyl and 6 $\omega$ - $\alpha$ -furoyl derivatives (Jaffé, *I.e.*; Shiple and Sherwin, *J. Biol. Chem.* 1922, 53, 463; Growdle and Sherwin, *ibid.* 1923, 55, 15, 363). Z-Ornithine is intimately concerned with the synthesis of urea, which, it has been suggested, takes place in the mammalian liver by a cyclic process of the following type (Krebs and Henseleit, *Z. physiol. Chem.* 1932, **210**, 33; Krebs, *Biochem. J.* 1942, 86, 758, and intervening papers; *see also Ann. Rev. Biochem.* 1943, 12, 190):

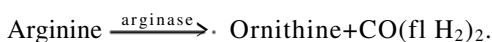
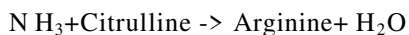
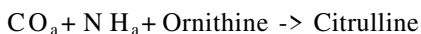

By the use of isotopically labelled materials the metabolic relationship of Z-ornithine to glycine on the one hand and to proline, arginine, and glutamic acid on the other has been demonstrated (Shemin and Rittenberg, *J. Biol. Chem.* 1945, **158**, 71; Clutton, Schoenheimer, and Rittenberg, *ibid.* 1940, 132, 227; Roloff, Ratner, and Schoenheimer, *ibid.* 1940, 136, 561; Stetten and Schoenheimer, *ibid.* 1944, 153, 113). It is possible that ornithine may be concerned in the biosynthesis of nicotinic acid (M. Guggenheim, "Die Biogenen Amine," Basle, 1940, p. 174). For the estimation of Z-ornithine manometrically by the use of a specific decarboxylase preparation, *see Gale, Biochem. J.* 1945, 39, 46.

Z-Ornithine forms salts with acids and reacts with a variety of precipitants for bases. The *monohydrochloride*,  $\text{C}_6\text{H}_{12}\text{O}_2\text{N}_2\cdot\text{HCl}$ , has  $[\alpha]_D^{25} + 11^\circ$  ( $c=5.5$  in water); the *dihydrochloride*,  $\text{C}_6\text{H}_{12}\text{O}_2\text{N}_2\cdot 2\text{HCl}$ , has  $[\alpha]_D^{25} + 16.7^\circ$  ( $c=5.3$  in water) (Jaffé, *I.e.*; Hunter, *I.e.*). Both the *monopicrate*,  $\text{C}_6\text{H}_{12}\text{O}_2\text{N}_2\cdot\text{C}_6\text{H}_3\text{O}_7\text{N}_3$  (slender needles from concentrated aqueous solution), and the *dipicrate*,  $\text{C}_5\text{H}_{12}\text{O}_2\text{N}_2\cdot 2\text{C}_6\text{H}_3\text{O}_7\text{N}_3$ , (rhombic prisms from 50% alcohol), darken at  $200^\circ$ ; m.p.  $208^\circ$  (decomp.) (Vickery and Cook, *I.e.*). For the separation from other bases as the picrate, *see Kossel and Weiss. (Z. physiol. Chem.* 1909, 59, 499); by the use of permittit, *see Felix and Lang (ibid.* 1929, **182**, 133).  $\Lambda$ -Ornithine *r*-*onvdphate*,  $(\text{C}_6\text{H}_{12}\text{O}_2\text{N}_2)_a\cdot\text{H}_a\text{SO}_4$ , darkens at  $225^\circ$ ; m.p.  $234^\circ$  (decomp.);  $[\alpha]_D^{25} + 8.4^\circ$  (water); is a useful salt for purposes of identification (Vickery and Cook, *I.e.*). For other salts and double compounds, *see Schulze and Winterstein (ibid.* 1901, 34, 128); Kiesel (*ibid.* 1922, **118**, 262).

Among derivatives suitable for identification of Z-ornithine are: the *U*<sup>a</sup>*N*<sup>d</sup>-*bis*- $\gamma$ -*naphthalene-sulphonyl* derivative,  $\text{C}_6\text{H}_{10}\text{O}_2\text{N}_2(\text{SO}_2\text{C}_{10}\text{H}_7)_2$ , m.p.  $191\text{--}192^\circ$  (Riesser, *Z.c.*); the *phenylhydantoin*,  $\text{C}^a\text{HaoOaN}^b$  m.p.  $208\text{--}209^\circ$ ,  $[\alpha]_D^{25} - 48^\circ$  ( $c=2'$  in pyridine) (Dakin, *J. Biol. Chem.* 1942, **146**, 237). The *N*<sup>d</sup>*N*<sup>\*</sup>-dibenzoyl derivative, 1-*ornithuric acid*,



forms needles from alcohol, m.p.  $188\text{--}189^\circ$  (Sørensen, *Chem. Zentr.* 1905, II, 461; Jaffé,

*Z.c.*), insoluble in cold water, sparingly soluble in ether and has  $[\alpha]_D^{25} - 1.6^\circ$  ( $c=2.48$  in methanol) (Karrer and Ehrenstein, *Z.c.*); methyl ester, m.p.  $145\text{--}146\text{V}7$  [ $\alpha]_D^{25} - 13\text{--}24^\circ$  ( $c=1.436$  in methanol). *N*<sup>d</sup>-*monobenzoyl-l-ornithine*,

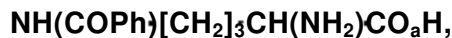

obtained by the action of 20% hydrochloric acid on Z-ornithuric acid, forms needles from hot water, m.p. ca.  $240^\circ$  (Sørensen, *L.c.*; Jaffé, *Z.c.*). *N*<sup>a</sup>-*monobenzoyl-l-ornithine*,



obtained by the action of baryta on Z-ornithuric acid, forms crystals from water, m.p.  $224\text{--}226^\circ$ ,  $[\alpha]_D^{25} + 8.03^\circ$  ( $c=2.79$  in water) (Karrer and Ehrenstein, *I.e.*). *u*

For *d*(-)-ornithine, *a*<sup>\*</sup>*d* derivatives, *see Sørensen (Z.c.)*.

*l*-Ornithine may be obtained by hydrolysis of Z-arginine or a suitable derivative with barium hydroxide solution; for a convenient procedure, *see Kurtz (J. Biol. Chem.* 1938, 122, 477). Alternatively, the racemisation and hydrolysis of arginine may be effected by the method of Bergmann and Köster (*Z. physiol. Chem.* 1926, **159**, 179). *d*Z-Ornithine was first obtained synthetically by Fischer (*Ber.* 1901, 34, 454), who brominated ethyl  $\gamma$ -phthalimidopropylmalonate and hydrolysed the product to  $\alpha$ -bromo-5-phthalimido- $\gamma$ -valeric acid, which was animated, and the product hydrolysed with hydrochloric acid to give (ZZ)-ornithine hydrochloride:

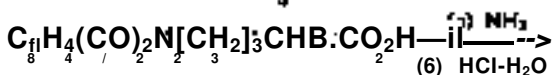
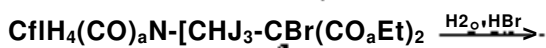

*d*Z-ornithine hydrochloride.

Subsequently, syntheses have been effected from ethyl  $\gamma$ -phthalimidopropylphthalimidomalonnate by Sørensen (*Z.c.*; *Compt. rend. Trav. Lab. Carlsberg*, 1903-6, 6, 1); from  $\gamma$ -vinylacrylic acid by Fischer and Baske (*Ber.* 1905, 38, 3607); from piperidine by Fischer and Zemplén (*Ler.* 1909, 42, 1022); from acrolein by Keimatsu and Sugawara (*J. Pharm. Soc. Japan*, 1928, 48, 24); from  $\alpha$ -amino adipic acid by Adamson (*J.C.S.* 1939, 1564), and by Fox, Dunn, and Sioddard (*J. Org. Chem.* 1941, 6, 410). In the last-named synthesis, which is convenient in that it allows the ready preparation of ca. 100 g. of material,  $\alpha$ -Z-pentanone is converted by hydroxylamine to the oxime, which is rearranged by 30N. sulphuric acid, and the  $\alpha$ -piperidone so obtained hydrolysed to 8-amino-*n*-valeric acid. The *l*M-benzoyl derivative is then brominated and amidated to give *N*<sup>d</sup>-monobenzoyl-*l*-ZZ-ornithine, giving (ZZ)-ornithine hydrochloride on hydrolysis with hydrochloric acid.

*l*Z-Ornithine has been obtained as crystals from water, sparingly soluble in alcohol. The *monohydrochloride* has m.p.  $233^\circ$  (decomp.) (Fox,



Duilm, and Stoddard, *I.e.*); the *monosulphate*, mp. 234° (decomp.) and the *dipicrate*, m.p. 208° (decomp.), (Vickery and Cookie). *N<sup>o</sup>N<sup>o</sup>-W<sup>o</sup>-naphthalenesulphonyl-di-ornithine* has m.p. 195-196°; see *phenylhydantoin* m.p. 191-192° (Dakin, *I.e.*). The *H<sup>o</sup>H<sup>o</sup>-dibenzoyl* derivative, *dl-ornithuric acid*, obtained by benzylation of *dl-ornithine* by the Schotten-Baumann method (Fischer, Ber. 1901, 34, 462) forms needles from alcohol, m.p. 187-188°. The monobenzoyl derivatives of *dZ-ornithine* are obtained by methods analogous to those used for the isomers; *N<sup>o</sup>-monobenzoyl*, m.p. 285-288° (Sorensen, *ibid.* 1910, 43, 643); *N<sup>a</sup>-monobenzoyl*, m.p. 264-267° (Sorensen, *I.e.*; Sorensen, Høyrup, and Andersen, Z. physiol/Chem. 1911, 76, 52).

For *dipoptides* of ornithine, see Bergmann and Köster (*ibid.* 1027,167, 91).

B. L.

\*O R P I M E N T. Arsenic triphide, As<sub>2</sub>S<sub>3</sub>. Crystallises in the monoclinic system, crystals being rare and short prismatic, tabular, and pseudo-orthorhombic in form. The mineral usually occurs in foliated or scaly masses which can be split easily parallel to the perfect clinopinacoidal cleavage. Orpiment is very soft (hardness, 1J-2) and sectile, its cleavage lamellae being flexible but not elastic; p 3<sup>49</sup>. Colour lemon-yellow, the lustre being resinous, and pearly on the cleavage surfaces. The mineral forms as a low-temperature product in hydrothermal veins and occasionally as a hot-spring deposit. It also occurs as an alteration product of other arsenic minerals, especially realgar (?). When orpiment is produced artificially by heating arsenic acid with hydrogen sulphide under pressure; it is colloquially called King's yellow." Formerly, the natural mineral was used as a yellow pigment, for dyeing, and by tanners for removing hair from skins, but for these industrial purposes it has now been largely superseded by artificial arsenic sulphide.

D. W.

ORRIS ROOT is the dried peeled rhizome of *Iris florentina*, *I. germanica*, or *I. pallida* (fam. Iridaceae) formerly esteemed as a cathartic but now used as an ingredient of toilet powders, dentifrices, and snuff. The chief odoriferous constituent, *o-irone* (v. Vol. VII, 62c), is found in the essential oil of orris (*concrete oil of orris, butter of orris*) which when diluted has an agreeable odour of violets. This yellowish oil, m.p. 40-41°, contains about 85% of odourless myristic anisoflavone glucoside, *iridin* (v. Vol. V, 211; VI, 90c), is present in the root, which also contains *irimin* (v. Vol. II, 3036) and other terpenoids in the fatty oil and sucrose (Colin *et al.*, A. T. H. 16, 1928, 803). For essential oil, see J. Niebault, Amer. Chem. Abstr. 1934, 28, 6530; J. Penner, *ibid.* 1935, 29, 3772; Sabbatini, Riv. V. f. z. e. profumi, piante offic. 1936, 18, 86, 127. *Iridin* (v. *supra*) is also the name of a resinoid contained in the drug iris (*Iris versicolor*).

ORSELNIC ACID (Vol. VII, 2936) is a complex rare earth silicate of variable composition belonging to the orthopyroxene group of minerals, and sometimes cerium-epidote. It contains cer-

tain of the cerium metals—cerium, neodymium, praseodymium, and lanthanum—and in smaller amounts the metals of the yttrium group. The general formula is  $M^I M^{II} (SiO_4)_3(OH)$ , where  $M^I = Ca, Fe, Mn$ , and  $M^{II}$  includes Al, Fe, Ce, La. A recent analysis of orthite from Colorado gave: SiO<sub>2</sub> 30-40, Al<sub>2</sub>O<sub>3</sub> 10-25, FeO 10-29, Fe<sub>2</sub>O<sub>3</sub> 10-33, Ce<sub>2</sub>O<sub>3</sub> 14-61, (La,Tb)<sub>2</sub>O<sub>8</sub> + Y<sub>2</sub>O<sub>3</sub>, etc. 10-23, MnO 0-66, CaO 7-47, MgO 1-44, K<sub>2</sub>O 0-16, TiO<sub>2</sub> 1-46, H<sub>2</sub>O 1-95%, and small amounts of other constituents. It must be emphasised, however, that the composition of orthite is subject to wide variations. The mineral crystallises in the monoclinic system, often with a prismatic appearance, and is commonly found massive or in irregular grains. It is brown to pitch-black in colour, and may be coated with yellowish-brown decomposition products. On freshly fractured surfaces it displays a submetallic, pitchy to resinous lustre, p 3-5-4-2; hardness 5J-6. Orthite occurs as a minor constituent in many igneous rocks, notably in granites, syenites, and pegmatites, sometimes developing as large masses in the last-named rock. It is a minor source of cerium, used in the separation of metals from refractory oxides and as a gas purifier in the manufacture of neon lamps; also in making ferrocerium pyrophoric alloys and various cerium compounds.

D. W.

ORTHOBARIC DENSITY. The density of a liquid (*d<sub>l</sub>*) and of its saturated vapour co-existing in equilibrium with it (*d<sub>v</sub>*) at the same temperature are called *orthobaric densities*. They are generally determined by the method of S. Young (J.C.S. 1891, 59, 37) in which different weights of material are sealed in evacuated glass tubes of sufficient strength to withstand the pressures developed, and the volumes occupied by the gas (*V<sub>v</sub>*) and the liquid (*V<sub>l</sub>*) are determined. This requires only the measurement of the length occupied by either gas or liquid in a tube which has been previously calibrated by volume. The total weight (*W*) of material in the tube is then given by:

$$W = V_l d_l + V_v d_v$$

Since there are two unknowns (*d<sub>l</sub>* and *d<sub>v</sub>*), two determinations with different weights and simultaneous equations from which both quantities can be found. In accurate work it is necessary to allow for the volume of liquid in the meniscus, but corrections for the change of volume of the tube due to increases of temperature and pressure are generally negligible.

Since, in general, liquids expand on heating, but vapour pressures and densities increase, the orthobaric densities approach one another with rise of temperature, and become coincident at the critical temperature. Graphs of orthobaric densities of a substance as a function of temperature therefore form a continuous curve, similar in shape to the example shown in Fig. 1, which is that for carbon dioxide, taken from the paper of Lowry and Erikson (J. Amer. Chem. Soc. 1927, 49, 2729).

The figure also illustrates the most interesting property of orthobaric densities, namely, that their arithmetic mean is a linear function of

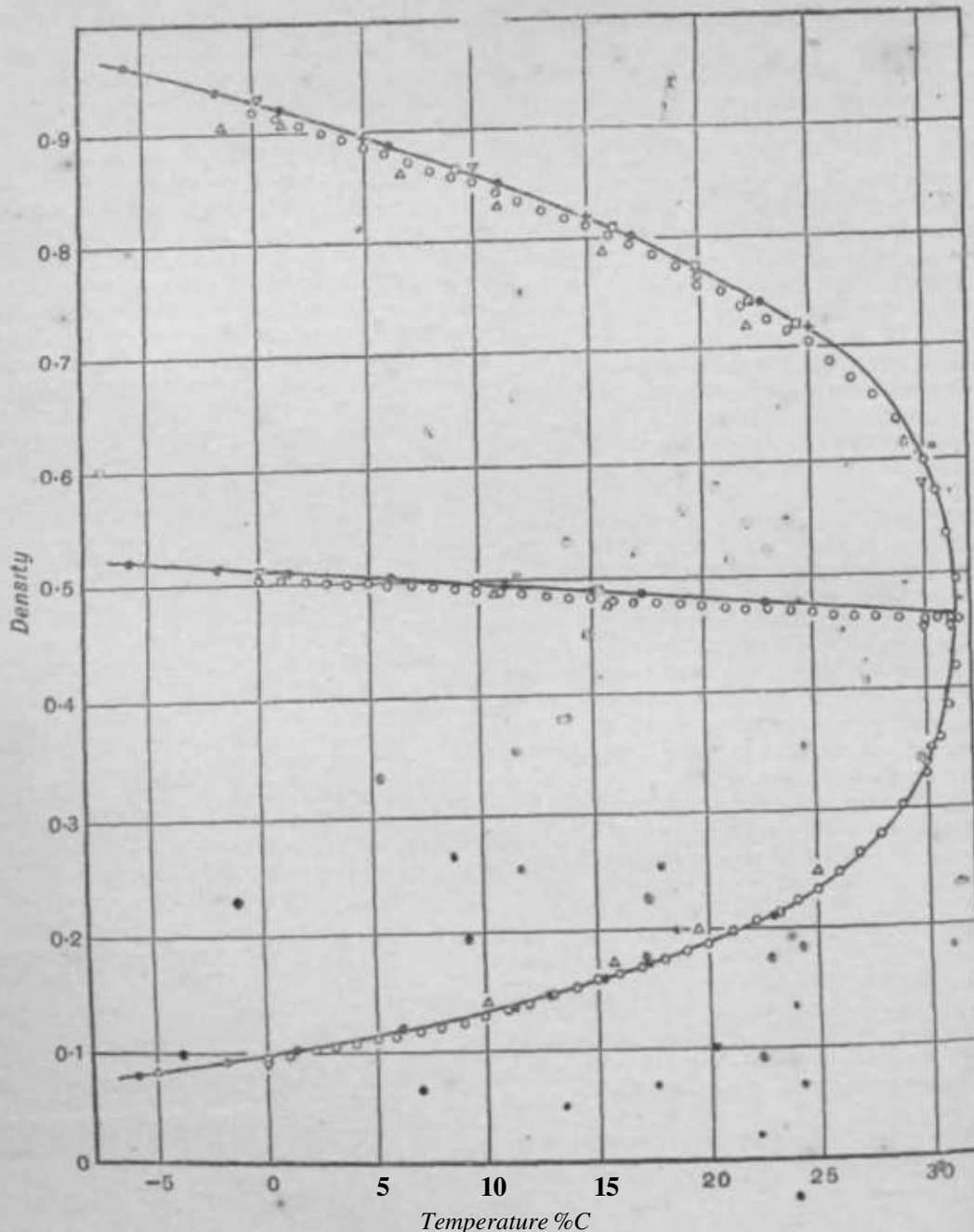

FIG. 1.

temperature. Thus, in the case of carbon dioxide, Lowry and Erikson found:

$$\frac{1}{\rho} \{ (d_t)_t + (d_0)_t \} = 0.4683 + 0.001442(t_c - t)$$

(where  $t_c$  is the critical temperature, 31.0°C).

This relationship, due to Cailletet and Mathias (1886) is known as the Law of Rectilinear Diameters; it is particularly useful in helping to locate the exact position of the critical point, as will be clear from the figure.

J. A. K.

**ORTHOCAINE.** Methyl m-amino-p-hydroxybenzoate. Local analgesic and antiseptic. B.P., B.P.C. (». STSHTETIC DEUGS).

S. E.

**ORTHOCLASE,** Potash Felspar {«. FELSPAR, Vol. V, lo).

### ORTHODENE.

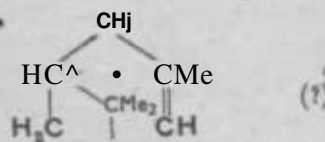

b.p. 16S-170°/757 mm.,  $\rho_f$  0.8430,  $\rho_c$  1.4670,  $[\alpha]_D +32.6^\circ$ . Occurs in the oil from the roots of *Ortkodon Janctolatum* (Fujita, J. Chem. Soc. Japan, 1033,54,1181).

J. L. B.

**ORTHOFORM, NEW** v. ORTHOCADTB-  
**ORTHOHYDROGEN** {«. HVDBOGIN, Vol. VI, 308d).

ORYZANIN. Former name for vitamin-B<sub>2</sub> (v. Vol. II, 60c, 4926).

OSAGE ORANGE TREE?. The wood of this tree, *Madura pomifera* Raf., found throughout south-eastern Oklahoma and eastern Texas, possesses dyeing properties similar to those of old fustic (v. this Vol. p. 81c), but the shades produced are slightly purer, less red, and faster to light. A qualitative examination of the aqueous extract showed that the dyeing principles present consisted, as in old fustic, of morin and maclurin (Kressmann, Textile Colorist, 1914, 36, 97; J. Amer. Leather Chem. Assoc. 1915, 10, 347; Desmurs, J. Soc. Leather Trades' Chem. 1928, 12, 424).

Two colouring matters, *osajin*, C<sub>26</sub>H<sub>24</sub>O<sub>5</sub>, m.p. 189°, and *pomiferin*, C<sub>28</sub>H<sub>24</sub>O<sub>6</sub>, m.p. 200-5°, are present, probably in the free state, in the fruit of *Madura pomifera*. The two pigments are closely related, pomiferin being a dihydro-derivative of osajin.

Catalytic hydrogenation converts both pigments into di- and tetra-hydro-compounds showing the presence of two ethylenic linkages. Osajin and pomiferin are isomerised to colourless products, iso-osajin, m.p. 285° (decomp.), and pomiferin, m.p. 265° (decomp.), respectively. The action of sulphuric acid in acetic acid on the hydro-derivatives are similarly isomerised, in the case of iso-osajin and tetrahydropomiferin, to form mono- and dimethyl ethers.

Osajin dimethyl ether is converted by mild alkaline treatment into formic acid (1 mol.) and trimethyl ether (I; R = H), which with concentrated sulphuric acid gives rise to pomiferin trimethyl ether and osajin dimethyl ether.

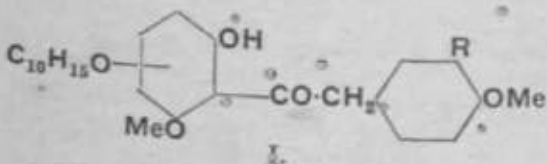

These, and other, facts indicate that osajin and pomiferin are isoflavone derivatives, and the following formulae are assigned:

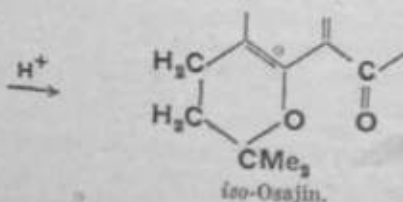
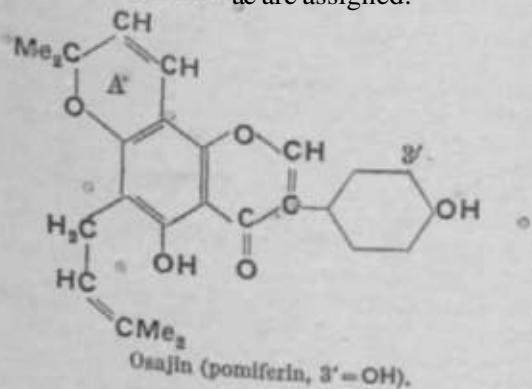

Both osajin and pomiferin yield 0.7 mol. of acetone on ozonisation, and this establishes the presence of the isopropylidene group. In the acid isomerisation of osajin and pomiferin a double bond and a phenolic group disappear, presumably by addition of the phenolic group to the double bond to form a cyclic ether.

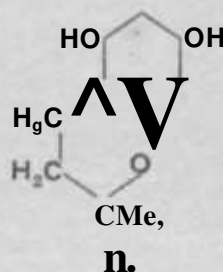

Alkaline fusion of iso-osajin and pomiferin gives acetone and 2:2-dimethyl-5:7-chromandiol (II). The formulation of ring A rests upon the known fact (cf. Robertson *et al.*, J.C.S. 1937, 279, 1530) that such a structure yields acetone on alkaline fusion (Wolfram *et al.*, J. Amer. Chem. Soc. 1938, 60, 574; 1939, 61, 2832; 1940, 62, 051, U84; 1941, 63, 422, 1248, 1253, 3356; 1942, 64, 308, 311; 1943, 65, 1434).

E. J. C.

OSAJIN, isoOSAJIN (w. OSAOK ORANGE TREE, *supra*).

OSAZONES (v. Vol. III, 293e; VI, 302c).

OSCILLATOR, ENERGY OF (». MOLBCDLAK SPECTRA, Vol. VIII, I86«).

OSMIRIDIUM (v. JHIUSMINB, Vol. VII, 296).

OSMIUM. Sym. <sup>167</sup>Os. At. no. 76. At. wt. 190.2.

Occurrence.—Practically the only natural source of osmium is osmiridium (». IKTDOSMINE, Vol. VII, 296), but small quantities of the metal are found in the very rare ruthenium sulphide mineral *laurile*, (v. Vol. VII, 196c). Although osmiridium is almost always found associated with native platinum, it is very doubtful whether the platinum mineral itself ever contains more than traces of osmium. At one time the chief source of osmiridium was alluvial gravels in Tasmania, but this source is now almost worked out and, apart from that which is produced in Russia as a minor constituent of the platinum concentrated from the Ural Mountains, Siberia, no details of which have been published for many years, the chief source of the mineral is the black-sand concentrates derived from the banket in the Witwatersrand gold reef. The platinum concentrates found in the Good News Bay area of Alaska contain 10-20% of an iridium-rich variety of osmiridium which contains 13-14% of osmium. Analyses of some typical osmiridiums have been given in the article on Iridium (». Vol. VII, 27a).

Extraction of Osmium from Osmiridium.—The South African mineral is decomposed by fusion with twice its weight of sodium peroxide in an iron crucible; this treatment converts the osmium and ruthenium into soluble sodium perosmate and perruthenate, and the iridium and base metal into alkali compounds which are decomposed by water with the precipitation of hydroxides. The melt is, therefore,

extracted with warm water, the insoluble material allowed to settle, and the deep-brown solution decanted. The precipitate is washed several times with dilute alkaline sodium hypochlorite solution until no further brown solution is obtained. Addition of alcohol to the clear solution and washings precipitates the ruthenium as hydrated dioxide and reduces the perosmate to violet osmate. The violet solution is decanted and treated with an excess of potassium hydroxide, which precipitates violet crystals of potassium osmate, generally contaminated with a little iridium and platinum. Distillation of the crystals with nitric acid volatilises the osmium as the tetroxide, which is caught in hot 1:1 hydrochloric acid containing alcohol to reduce it to osmium tetrachloride. Addition of ammonium chloride to the solution produces a precipitate of ammonium chlorosmate, which, like the corresponding platinum compound, is only very slightly soluble in ammonium chloride solution. The ammonium chlorosmate is heated in a closed graphite pot, from which air is completely excluded, in order to obtain metallic osmium.

Small quantities of osmium which are not precipitated in any of the stages of this process may be recovered by boiling the neutralised solution with sodium sulphide, which precipitates osmium sulphide; distillation with nitric acid converts this into the volatile tetroxide.

An alternative procedure for recovering osmium from alkaline osmate solution consists in treating it with concentrated ammonium chloride solution, which produces a precipitate of orange-yellow crystal of tetramminosmyl chloride,  $[\text{OsO}_2(\text{NH}_3)_4]\text{Cl}_2$ ; this, on heating to dull redness in a non-oxidising atmosphere, yields osmium sponge. This may contain some platinum and iridium if the original osmate solution was obtained by fusion of osmiridium with sodium peroxide; it may be purified by heating in oxygen and converting the resisting osmium tetroxide distillate into tetrachloride, as described above, or the tetroxide may be collected in alcoholic sodium hydroxide and the resulting sodium osmate solution exactly neutralised with dilute sulphuric acid to precipitate hydrated osmium dioxide, which is converted into metal by heating with ammonium chloride in a reducing atmosphere.

Properties.—The metal produced by any of the above refining processes consists of a heavy blue-grey powder, which oxidises in air slowly at room temperature unless it has previously been heated for some time at a temperature exceeding  $1,200^\circ$ . Compact metal may be produced by pressing the powder into rods and sintering these at  $2,000$ - $2,500^\circ$  in an atmosphere of hydrogen. The metal melts at about  $2,700^\circ$ . Both the melted and the sintered metal are extremely hard and quite unworkable. Osmium has a hexagonal structure with  $a$  2.7304 Å. and  $c$  1.5785, which indicates a theoretical density of 22.61, although the highest values found directly range between 22.4 and 22.5 (E. A. Owen, L. Pickup, and I. O. Roberts, Z. Krist. 1935, 91, 70). The specific heat at  $0^\circ$  is  $0.030986$  and the temperature coefficient  $4.721 \times 10^{-6}$ ; the atomic heat is  $6.9152 + (9019 \times 10^{-4})t$  (F. M.

Jaeger and E. Bosenbohm, Proc. K. Akad. Wetensch. Amsterdam, 1931, 34, 85). Osmium can be boiled in a graphite arc furnace, but does not volatilise appreciably at temperatures below  $2,000^\circ\text{C}$ . in the absence of oxygen; in the presence of even small quantities of oxygen the volatile tetroxide is formed at relatively low temperatures.

Osmium does not alloy with gold, silver, copper, or lead, but forms brittle intermetallic compounds with tin and zinc. It alloys readily with the other platinum metals and with iron, cobalt, and nickel, forming hard alloys which evolve the vapour of osmium tetroxide on heating to redness in the air. Practically the only use for metallic osmium is in the manufacture of hard alloys, for use in tipping fountain-pen nibs and as pivots in scientific instrument\*. These alloys generally contain tungsten and cobalt as the major alloying constituents, and many other metals have been used as minor constituents. Osmium tetroxide is used for staining tissues in biological work.

#### COMPOUNDS OF OSMIUM.

Osmium Oxides.—Only the dioxide,  $\text{OsO}_2$ , and the tetroxide,  $\text{OsO}_4$ , appear to be definite compounds. The hydrated dioxide,  $\text{OsO}_2 \cdot 2\text{H}_2\text{O}$ , is forced as a black precipitate by carefully neutralising with dilute sulphuric acid a solution of sodium osmate containing alcohol. When the washed precipitate is heated in a current of carbon dioxide at  $300$ - $400^\circ$  all the water is expelled, a heavy greyish-black powder of  $\text{OsO}_2$  being left. Osmium tetroxide is formed by heating osmium sponge or any osmium compound in a current of air or oxygen. It forms a yellowish-white crystalline mass, which melts to a pale-yellow liquid at  $41^\circ\text{C}$ .; the liquid boils at about  $130^\circ\text{C}$ ., although it begins to distil well below its boiling-point. The vapour pressure of the liquid at  $T^\circ\text{K}$ . is given by  $\log p = 10.10014 - 5/T + 5.49$ . The heat of formation is  $93.37$  kg.-cal. per g.-mol., the critical temperature  $405^\circ$  and the critical pressure  $170$  ttm. Osmium tetroxide has a powerful penetrating odour perceptible at a dilution of  $0.02$  mg. per litre of air. The vapour attacks the mucous membrane of the nose, throat, and eyes, inducing copious formation of tears and blurring the vision for some hours after exposure. The vapour and solution stain the skin black, owing to reduction of the tetroxide to the hydrated dioxide.  $100$  g. of water dissolve  $0.47$  g., and  $100$  g. of carbon tetrachloride about  $250$  g. of osmium tetroxide.

Potassium Osmate,  $\text{K}_2\text{OsO}_4 \cdot 2\text{H}_2\text{O}$ , is prepared by fusing osmium with sodium peroxide, extracting the melt with water, reducing the dark brown solution of perosmate to osmate with alcohol, and adding potassium hydroxide. It forms violet crystals, soluble in water but almost insoluble in potassium hydroxide solution\*.

Osmium Disulphide,  $\text{OsS}_2$ , has been prepared as black crystals with a cubic lattice of the pyrite type ( $a$  5.6 Å.). A brown sulphide of rather indefinite composition is obtained by passing hydrogen sulphide into an alkali osmate solution.

Osmium Fluorides.—Three fluorides are known. The octafluoride,  $\text{OsF}_8$ , prepared by

treating Osmium powder with an excess of fluorine, forms lemon-yellow crystals which melt at 34.5° to a yellowish-red liquid. Its existence is definitely established by the octavalency of osmium. The hexafluoride,  $\text{OsF}_6$ , is formed by the action of fluorine on osmium at 250° as a yellowish-green crystalline sublimate, which melts below 120° to a liquid boiling at about 205°. The tetrafluoride,  $\text{OsF}_4$ , is produced by the action of fluorine at 280° on sponge which has been produced at a red heat. It has not been isolated in the pure state, but double salts with the alkali fluorides corresponding to the chlorosmates have been obtained.

**Osmium Chlorides.**—The tetrachloride,  $\text{OsCl}_4$ , is formed as black crystalline crusts, which sublime to a yellow vapour, by treating osmium sponge with chlorine at 650-700°. The trichloride,  $\text{OsCl}_3$ , is produced by heating osmium in chlorine at 1,050° and cooling the vapours rapidly, or by heating ammonium chlorosmate in chlorine at 350°, when it forms a brownish-black microcrystalline sublimate. The trichloride dissociates to the dark brown dichloride when heated to 500° under low pressure.

**Chlorosmic Acid,  $\text{H}_2\text{OsCl}_6$** , is formed in solution when osmium tetroxide is reduced by boiling with hydrochloric acid and alcohol under reflux. The resulting reddish-yellow solution yields sparingly soluble brown crystalline precipitates with ammonium, potassium, rubidium, caesium, and thallium chlorides. Corresponding osmosmates have been prepared similarly.

Potassium Nitroschlorosmate,

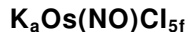

separates in orthorhombic crystals when potassium nitrite is boiled with concentrated hydrochloric acid, and is isomorphous with the corresponding ruthenium compound and is likewise remarkably stable, even boiling with nitric acid causing only slow evolution of the osmium tetroxide.

**Osmic Acid,  $\text{HNOsO}_3$ .**—Salts of this acid, which is not known in free state, are obtained by treating solutions of osmium tetroxide with caustic alkalis with ammonia. The potassium salt,  $\text{KNOsO}_3$ , and the potassium salt,  $\text{KNOsO}_3$ , are soluble in water and in alcohol, and the mercurous salt is soluble in both. All the salts violently detonate on heating or by percussion. *M. L. G. and J. E. Zandstra, P. A. C. K. Akad. Wet. h. Amsterdam, 610, 779, 787.*

**Osmium Nitrite,  $\text{Os}(\text{NO})_2$** , is prepared as a brown powder by decomposing ammonium nitrite,  $\text{Ba}(\text{NO}_2)_2 \cdot \text{H}_2\text{O}$ , with dilute sulphuric acid and evaporating the solution. It forms a stable series of basic nitrates with the alkali and alkaline earth metals, magnesium, zinc, cadmium, and silver. The nitrates are best prepared by boiling a solution of osmium tetroxide with the corresponding metal nitrite, or by double decomposition of a barium salt with the metal nitrite. The various amounts of water of crystallisation, and are generally readily soluble in water.

**Osmium Carbonyls.**—Carbon monoxide under high pressure reduces osmium tetroxide to the carbonyls  $\text{Os}_2(\text{CO})_9$  and  $\text{Os}(\text{CO})_6$ , according to the conditions. The higher carbonyl is a colourless liquid at ordinary temperatures and readily decomposes into  $\text{Os}_2(\text{CO})_9$ , which crystallises in the hexagonal system and melts at 224°, but begins to sublime above 130°. The carbonyls can also be prepared by reaction of an osmium halide with carbon monoxide under high pressure in the presence of copper, which combines with the liberated halogen. Carbonyl derivatives containing halogen are produced by treating osmium halides with carbon monoxide;  $\text{Os}(\text{CO})_4\text{Cl}_2$  and  $\text{Os}(\text{CO})_4\text{Br}_2$  have been prepared (W. Hieber and H. Stallmann, Z. Elektrochem. 1943, 49, 288).

**Osmocyanides.**—The potassium salt,



is obtained by heating ammonium chlorosmate with potassium cyanide at a dull red heat and extracting the product with hot water; on cooling, the salt separates in fine yellow crystals. Addition of concentrated hydrochloric acid to the cold saturated solution of potassium osmocyanide results in the slow precipitation of white crystalline scales of osmocyanic acid,  $\text{H}_4\text{Os}(\text{CN})_6$ .

**Detection of Osmium.**—The characteristic odour of osmium tetroxide is produced when osmium or any of its compounds is heated in air. Hydrogen sulphide produces brown to black precipitates both from acid solutions of osmium salts and from alkaline osmate and perosmate solutions. Osmium tetroxide or the tetrachloride gives a characteristic rose to deep-red colour when warmed with hydrochloric acid and thiourea. When an osmium compound is fused with sodium peroxide and the aqueous extract of the melt is distilled with nitric acid into sodium hydroxide solution, a brown solution of perosmate is produced which becomes violet on addition of alcohol (ruthenium gives a black precipitate) and the violet solution is decolourised by adding a large excess of solid potassium hydroxide, the osmium being precipitated as violet crystals of potassium osmate. The violet solution also gives a yellow crystalline precipitate with ammonium chloride, insoluble in hydrochloric acid, and decomposing on boiling with water into a brown solution with the evolution of osmium tetroxide.

A. E. P.

**OSMOPHORES.** *Odoriphorea.* Groups in, an organic compound which determine or influence the property of odour, e.g., hydroxyl and other groups possessing residual valency.

J. N. G.

**OSMOTIC PRESSURE.** The experimental and theoretical study of osmotic pressure has attracted the attention of a very large number of workers, and it is quite impossible to summarise their work in a short article. Much of it is now of historical interest only; a full account will be found in A. Findlay's monograph ("Osmotic Pressure," Longmans, 1919). The aim of this article is to present a concise account of the theoretical basis of osmotic pressure, and to describe the more recent experimental work, which is almost exclusively confined to the

determination of the molecular weight of high polymers, for which the method has proved invaluable.

The following theoretical treatment differs from that to be found in most text-books, but has the advantage of allowing a sharp distinction to be drawn between thermodynamic relationships (which, in their general form, are exact) and equations based on statistical calculations, which are of necessity approximate.

**Definitio n.**—If a solution is carefully covered with a layer of pure solvent, the two layers gradually mix by diffusion, until the solute concentration is the same throughout the system. If the solution and solvent are contained in vessels separated by a semi-permeable membrane, through which the solvent can pass, while the solute cannot, diffusion of the solvent proceeds just as in the absence of a membrane, and results in a net transfer of solvent into the solution. This transference can be prevented, or even reversed, by applying a hydrostatic pressure to the solution. For any given concentration of solution, there is a definite pressure (depending on the temperature) which just causes the net diffusion through the membrane to cease. By definition, this pressure is the osmotic pressure of the solution. It is not necessary that the solution should be fluid, and indeed an important application is to gels, *e.g.*, of rubbers-benzene. In this case it is customary to speak of the swelling pressure of the gel, but there is no distinction in principle (or in origin) between osmotic and swelling pressures.

**Origin.**—The origin of osmotic pressure has been the subject of much discussion (*c.f.* Findlay, *op. cit.*) and still does not appear to be at all generally understood. It is clear from the above definition that it arises from the tendency of the solvent to diffuse preferentially from solvent to solution. This diffusion tendency may be described in the language of kinetics or of thermodynamics. According to the former, osmosis occurs in the absence of any applied pressure because the solvent molecules, in their constant thermal motion, make more frequent collisions with the membrane on the solvent side than on the solution side. The effect of applying a hydrostatic pressure to the solution is, on this view, to increase the number of collisions with the membrane of solvent molecules from the solution, and/or the probability of a given collision resulting in the molecule penetrating the membrane. In the absence of any satisfactory kinetic theory of liquids it is impossible to develop this argument quantitatively, and all that can be said is that, at equilibrium, the pressure across the membrane will be equal to the osmotic pressure of the solution. It is not necessarily true, as is frequently stated, that this pressure is equal to the pressure exerted on the membrane by the solute molecules. It is still less true to say that the osmotic pressure is equal to the pressure exerted on the membrane by the solute molecules when the system is not in equilibrium. (A simple but convincing proof of the incorrectness of these statements is given by E. A. Guggenheim in "Modern Thermodynamics," Methuen, 1933, p. 85.)

Thermodynamics is not concerned with

mechanisms, and cannot, therefore, strictly describe the *origin* of osmotic pressure. It does, however, enable it to be related to a quantity susceptible of calculation by statistical methods, namely, the decrease in the free energy of the system which occurs when solvent is transferred from the solvent to the solution. If  $-AQ_0$  is the decrease of Gibbs free-energy on transferring one mole of solvent to a large bulk of solution, it may be shown (Guggenheim, *op. cit.*) by purely thermodynamic reasoning, that the osmotic pressure  $\pi$  of the solution is given by:

$$-dG_0 = \int_{P_0}^{P_0 + \pi} \bar{V}_0 dP \quad (1)$$

where  $\bar{V}_0$  is the partial molar volume of the solvent in the solution, and  $P_0$  is the hydrostatic pressure on the solvent. Since  $P_0$  is always small (usually 1 atm.) its effect on  $\bar{V}_0$  is negligible, and we may put  $P_0 = 0$ . For small osmotic pressures  $\bar{V}_0$  is practically independent of  $P$  and equal to the molar volume  $V_0$  of the pure solvent, so that (1) may be integrated to give:

$$\pi = -J_0 / F_0 \quad (2)$$

The "free energy of dilution"  $AQ_0$  may now be divided into heat ( $AH_0$ ) and entropy ( $AS_0$ ) terms

$$dG_0 = dH_0 - T dS_0 \quad (3)$$

For an ideal solution (more generally, for an athermal solution)  $AH_0 = 0$  so that (2) becomes:

$$\pi = -RT \ln V_0 \quad (4)$$

Equations (1) and (3), or the approximate forms (2) and (4) where applicable, relate the osmotic pressure to thermodynamic quantities which can be either calculated statistically, or related to other measurable quantities:

**Relation of Osmotic Pressure to Molecular Weight: Statistical Theory.**—The calculation of the entropy of dilution  $AS_0$  required the methods of statistical mechanics, with the assumption of a molecular model. For a solution in which the solvent and solute molecules are of approximately equal sizes, Guggenheim has shown that the problem may be solved by treating the solution as pseudo-crystalline, the two kinds of molecules being arranged at random on a crystal lattice (*c.f.* E. A. Guggenheim and R. H. Fowler, "Statistical Thermodynamics," Cambridge, 1939).

This procedure finds some justification in the demonstration that liquids do, in fact, possess local order, and are much more closely akin to crystals than to gases. Independently of the co-ordination number of the lattice (*i.e.*, the number of nearest neighbours of a molecule in the lattice), it is readily shown that:

$$\Delta S_0 \approx R \ln \left( \frac{1 + N_s}{N_0} \right) \quad (5)$$

where  $N_s$  and  $N_0$  are the numbers of solute and solvent molecules in the solution. For dilute solutions, the log term in (6) may be expanded, so that on substituting into (4) we obtain, for ideal, dilute solutions:

$$\pi = -RT \ln \left( \frac{1 + N_s/V_0}{1} \right) \approx -RT \left( \frac{N_s}{V_0} \right) = nRT/V \quad (6)$$



where  $n$  is the number of gram-molecules of solute contained in a volume  $V$  of solvent. Apart from the difference between the volumes of solvent and solution, this equation is formally identical with the ideal-gas law, a circumstance which has done much to foster the erroneous kinetic theories of osmotic pressure referred to above.

Equation (6) may also be written in terms of  $c$ , the concentration of the solution, and  $M_s$ , the molecular weight of the solute:

$$n = cRT/M_s \dots (7)$$

The equation in this form was first derived by van't Hoff, and forms the basis of the use of osmotic pressures to calculate molecular weights. It must be emphasised that it is only an approximate expression, requiring modification for application to real solutions. Two kinds of correction are needed, to take account of (1) finite heats of dilution, and (2) the different entropy of dilution of the solvent and solute molecules which differ markedly in size, or are not randomly mixed. The widespread application of osmotic-pressure measurements to solutions of high polymers has made this second factor extremely important.

It is not in general possible to calculate the heat of dilution absolutely by statistical methods, but it has been shown that  $\Delta H_{dil}$  may be expressed as a power series in  $v_2$ , the volume fraction of the solute, in which the first term involves  $v_2^2$  and the higher terms are frequently unimportant (c. J. H. Hildebrand, "Solubility," Reinhold, 1936). For dilute solutions,  $\Delta H_{dil}$  is nearly proportional to  $c$ , and we may write

$$\Delta H_{dil} = k_1 v_2^2 + k_2 v_2^3 + \dots (8)$$

\*a being a constant whence:

$$\Delta H_{dil} = RT/M_s k_1 c \dots (9)$$

It is evident from (9) that van't Hoff's law is not valid for real solutions, but that the limiting law at infinite dilution will give a

The work presented by solute and solvent molecules of different sizes is more difficult than the most important practical case being the solution of long-chain molecules. Approximate calculations of the entropy of dilution have been made on the basis of an unturned lattice structure which a solvent molecule occupies one site, while the solute molecule occupies  $z$  sites, which are divisible into segments, between which the solute molecule can rotate freely. See S. J. Miller, Proc. Camb. Phil. Soc. 1949, 45, 1243, 39, 54, 131. The entropy of dilution is independent on the co-ordination number  $z$  of the lattice. Miller's expression

$$\Delta S_{dil} = -R[\log_e(1-v_2) - (z/2) \log_e \{1 - (z/2)v_2\}] \dots (10)$$

where  $v_2$  is the molar fraction of the solute. For dilute solutions

of dilute solutions incorporating a heat of dilution given by (8), the final expression for

the osmotic pressure of a dilute solution of a long-chain polymer may be written:

$$\Pi/c = RT/M_s + d(RT/M_s)^2 V_2^{1/2} (1/z) \dots (11)$$

where  $p_s$  is the density of the solute. This equation leads to the conclusion that not only does van't Hoff's law not hold for polymer solutions, but that except at very low concentrations, the first term is negligible for high polymers, and the osmotic pressure becomes nearly independent of the molecular weight of the polymer. Just as in the case of non-ideal solutions of low-molecular materials, we conclude from (11) that the limiting value of  $n/c$  at infinite dilution is  $RT/M_s$ , i.e., that van't Hoff's law is the correct limiting law at infinite dilution. Gee has shown (Trans. Faraday Soc. 1944, 40, 261), by a very general statistical argument, that the same is true for solute molecules of any shape or size. Hence, the statistical basis of the use of osmotic-pressure measurements for the calculation of molecular weights may be written:

$$M_s = RT \lim_{c \rightarrow 0} (\Pi/c) \dots (12)$$

This equation is of general validity and is independent of the nature of the solvent, or whether it is associated. Gee has also shown it to be true for solutions in mixed solvents (Trans. Faraday Soc. 1944, 40, 463). If the solute is solvated, the molecular weight found does not include the solvent thus attached. If the solute itself is associated, the "molecular weight" is that of the complex, but it must be pointed out that most molecular complexes would be broken down in solution at concentrations likely to be employed for osmotic-pressure measurements.

Relation of Osmotic Pressure to other Properties of Solutions.—Although thermodynamics does not enable us to calculate the osmotic pressure of a solution, it does give a series of relations between osmotic pressure, vapour pressure, freezing point, and boiling-point. We may regard all these "colligative properties" of the solution as determining the free energy of dilution; their relation to the concentration of the solution and the molecular weight of the solute rests on the statistical theory given above. The following thermodynamic results are given in their exact form; the relationships to molecular properties which follow are only approximate, but—like van't Hoff's equation—will be valid at infinite dilution.

Vapour Pressure.

$$\Delta G_0 = -RT \log_e (p/p_0) = -RT \log_e (p/p_0) \dots (13a);$$
$$p/p_0 = X_0 p_0^s \dots (13b);$$

where  $p/p_0$ ,  $p_0^s$  are the solvent fugacities in the solvent and solution;  $p/p_0$ ,  $p_0^s$  are the vapour pressures of solvent in the solvent and solution;  $X_0$  is the mol fraction of solvent in the solution.

Freezing-point of Solution.

$$\Delta G_0 = \int_{T_0}^{T'} L_f \cdot d(\log_e T) \dots (14a);$$

$$\log_e X_0 \approx -(L_f/RT^2)(T' - T) \dots (14b);$$



where  $T^\circ$ ,  $Z^\wedge$  are the freezing-points of solvent and solution ;

$L\$.$  is the latent heat of fusion of the solvent.

*Boiling-point of Solution.*

$$dO_{\infty} = - \int_{T^\circ}^{T^*} L_T \cdot d(\log_e T) \cdot (15a) ;$$

$$\log_e X_o c_2 = -(LyRT^{\circ 2})(T^* - T) \quad (16b) j$$

where  $T^\circ$ ,  $T^B$  are the boiling-points of solvent and solution ;

$L\%$  is the latent heat of evaporation of the solvent.

*Experimental Tests of Theory.* Although we do not wish to describe here the extremely careful and precise determinations made by Berkeley, Morse, Washburn and their co-workers, of the osmotic pressures of aqueous solutions (cf. Findlay, *op. cit.*), it is of importance to see how closely their results accord with the above theoretical equations. Comparison of experiment and theory falls under two heads:

1. The remarkably close agreement found between osmotic pressures measured directly and those calculated from vapour-pressure data shows the membrane used to be truly semi-permeable, and also gives evidence of the skill of the experimenters, since equation (13a) is exact. (The most striking example is the work of Berkeley *et al.* on the osmotic pressures of aqueous solutions of calcium ferrocyanide, in which osmotic pressures of up to 130 atm. were measured, and found to agree with values calculated from the vapour pressures to better than 1%.)

2. The extent to which equation (6) represents the osmotic pressure data is a measure of the validity of the assumptions involved in its derivation. The table below indicates the order of agreement found.<sup>0</sup>

OSMOTIC PRESSURE OF CANS SUGAR SOLUTIONS AT 0°C.

(Berkeley and Hartley, Proc. Roy. Soc. 1916, A, 92, 477.)

Weight concentration g/100 g. water.	77 (atm.)		$Aa^*iv\rho$ (atm.)!	$tt$ (corrected). *
	Observed.	Calculated from (6).		
3-3927	2-23	221 <sub>6</sub>	002	2-23
10184	6-85	6-63	0-25	6-88
20-526	14-2L	13-34	1-2	14-5 <sub>6</sub>
30-608	21-87	20-00	3-0	23-0
33-945	24-55	22-0	3-7 <sub>5</sub>	25-7 <sub>6</sub>
81-262	67-74	52-0		
111-731*	100-13	70-9		
141-107	134-84	88-9		

It is evident from this table that, while equation (6) represents the data at infinite dilution, the deviation increases with concentration, and becomes more than 50% in the most concentrated solution. A considerable part of this discrepancy arises from neglecting the heat of

dilution. The contribution made to the osmotic pressure is given in the fourth column, calculated from the calorimetric measurements of Pratt (J. Franklin Inst. 1918, 185, 663). The last column, containing the corrected, osmotic pressures, is in better agreement with experiment, but still shows the deviations at the higher concentrations, though now in the opposite sense. These almost certainly arise from a tendency of the sugar and water molecules to be associated in solution, thus reducing the state of disorder of the solution and consequently decreasing  $AS_o$ . This explanation may be regarded as a modern version of the older attempts to reconcile theory and experiment by assuming a definite degree of hydration of the sugar molecules (cf. Findlay, *op. cit.*). It may be noted that corrections for the compressibility of the solutions, and for the departure of the partial molar volume of water from the total molar volume are small, amounting at a concentration of 34 g. per 100 g. of water to approximately 0.1% of the measured osmotic pressure.\*

The Osmotic Pressures of Solutions of High Polymers, —(a) *Experimental Technique.*—The design of an osmometer for use with solutions of high polymers presents very different problems from those encountered in the classical work on sugar solutions. The pressures to be measured are extremely small, since, as we shall see, deviations from van't Hoff's law are usually serious at any concentration at which the osmotic pressure is measurable. Present practice aims at measuring pressures of the order of 5-50 mm. Of solution, and it is not usually possible to attain an accuracy much better than 1 mm. A number of different designs of instrument have been described (Adair, Proc. Roy. Soc. 1925, A, 108, 627; Dobry, J. Chim. phys. 1935, 32, 46; Schulz, Z. physikal. Chem. 1936, A, 176, 317; Boissonnas and Meyer, Helv. Chim. Acta, 1940, 23, 430; Carter and Record, J.C.S. 1939, 660; Montonna and Jilk, Z. Physical Chem. 1941, 45, 1374; Gee, Trans. Faraday Soc. 1940, 36, 1162; Geo and Treloar, *ibid.* 1942, 38, 147; Fuoss and Mead, J. Physical Chem. 1943, 47, 59; Flory, J. Amer. Chem. Soc. 1943, 65, 372). The two models shown in Figs. 1, 2, and 3, illustrate the main features, in Meyer's design (Figs. 1 and 2), the solvent and solution are contained in shallow cells turned out of two metal blocks, separated by the membrane, and clamped together by a ring of bolts. The membrane is supported on both sides by perforated plates. Each cell communicates with a glass tube and with a filling tube which can be closed by a metal needle-valve. After assembling and filling, the system is thermostatted and allowed to come to equilibrium, the final difference of level in the two glass tubes (corrected, if necessary, for capillarity) giving directly the osmotic pressure of the solution. Provided the faces of the metal plates are truly flat, no trouble should be experienced with leakage past the edges of the membrane, since a high pressure is readily applied. The metal-to-glass joints may be made with fusible metal (as in Meyer's design) or by fixing the glass on a thin-walled copper tube soldered into the metal

plate. Most of the recent osmometer designs are essentially of this pattern.

Carter and Record employed an all glass instrument (Fig. 3) in which a mercury seal was used to prevent leakage between the membrane and the rather narrow clamping surfaces. The

to keep the meniscus stationary; this is the osmotic pressure of the solution. By this dynamic method it is possible to obtain the final result more rapidly than is usually possible by the static method, although the latter is considerably accelerated if the liquid levels are set initially at approximately the equilibrium position.

Whatever type of osmometer is used, the most important factor in the success of the measurements lies in the use of suitable membranes. Extremely satisfactory ones have been produced commercially by the Membranfilter G.m.b.H., of Gottingen; these are the "Urafcinfilter" for aqueous solutions, and the "Uracellafilter" for non-aqueous solutions. When these are not available, membranes may be prepared either by the controlled swelling of cellulose film (e.g., "Cellophane") or by the denitration of nitrocellulose films. Carter and Record (J.c) used the former method, preparing membranes of

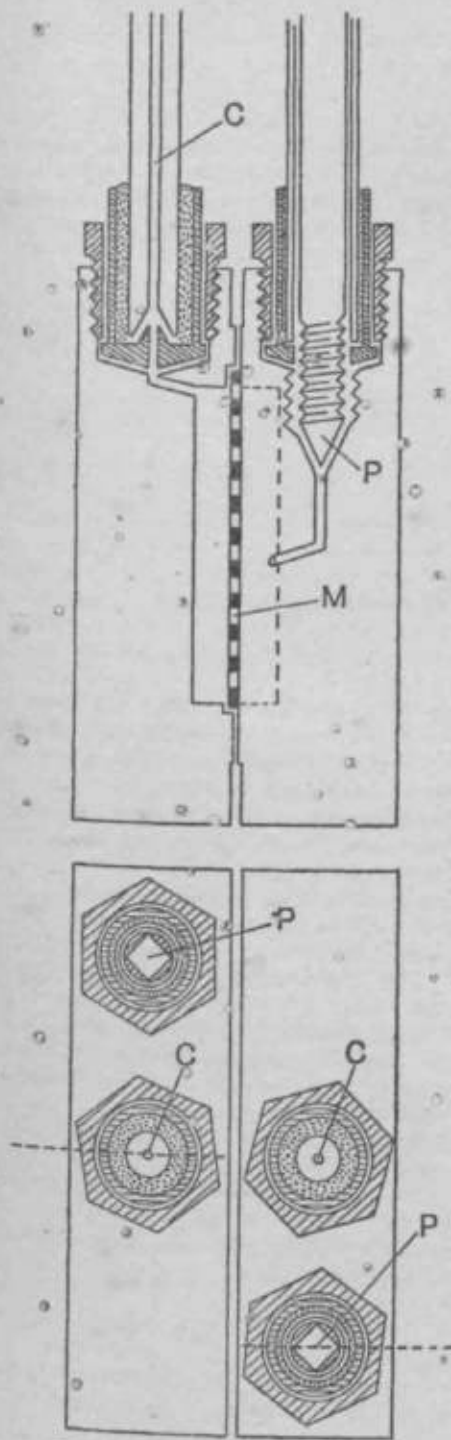

Figs. 1 (above) AKD 2 (below).

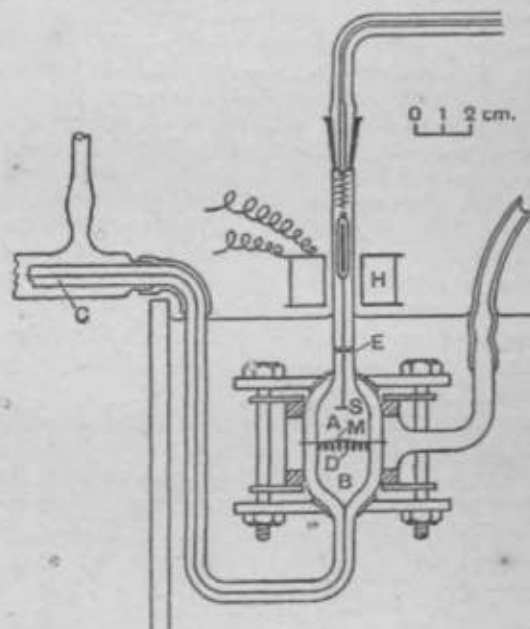

Fig. 3.

various degrees of permeability by swelling them in aqueous alcohol. By analysing the contents of the solvent chamber after each run they showed that the intra-molecular of the polysaccharides with which they were working tended to diffuse slightly through all but the least permeable membranes; when this occurred the osmotic pressure measured was lower than its true value. In measurements by the static method, this trouble is revealed by a slow drift of the pressure to progressively lower values, and can be confirmed by replacing the solution by fresh solvent, when a negative osmotic pressure is observed.

As the permeability of the membrane is reduced in order to prevent diffusion of the polymer, the time required for osmotic equilibrium is increased. A new approach to the dilemma thus created was made by Fuoss and Mead, who used partly denitrated collodion membranes of quite high permeability. They express the view that a satisfactory membrane

solv t level Waa in the A r ^ n t a l capillary o,  
and? - SIOtl was mad B for stirring the solution  
elePtS, S m ^ n e t i c a l l y - T h o method of operation  
coo - e a i n \* P P l y i n g a series of measured air  
pressu T \* X the s o l u t i o n . observing the ratio of  
anH \* \* \* s o l y e n t meniscus at each pressure,  
a < \* i n t e r p o l a t i n g to find the pressure required

should be not only permeable to the solvent, but actually swollen by it. Under these conditions the polymer diffuses through the membrane, but at a rate which is sufficiently slower than that of the solvent for measurements to be completed before any significant amount of polymer has diffused. In this way they were able to measure the osmotic pressure within 20 minutes of filling the osmometer—a great saving of time as compared with other methods, although this advantage may be partly offset by the difficulty of washing polymer out of the membrane subsequently. The method has been compared with the standard static method by Bartovics and Mark (*ibid.* 1943, 65, 1901) and showed good agreement; it appears likely, therefore, to be widely used in the future.

(b) *Interpretation of the Results.*—It was shown in the first section of this article that van't Hoff's law cannot be expected to hold generally for

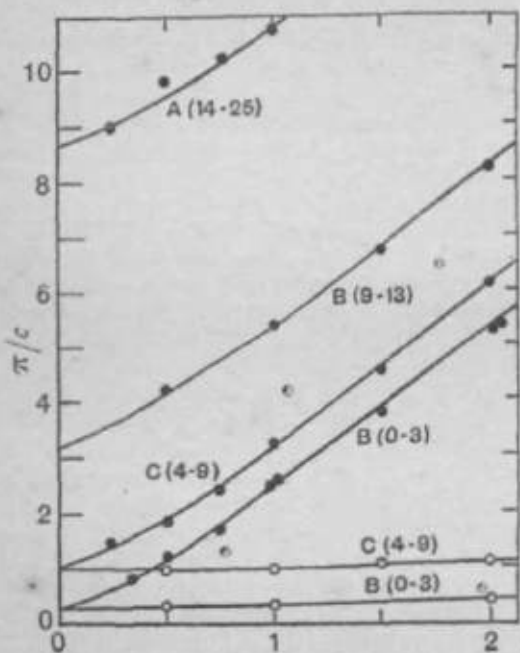

*c* in g. per 100 cc.

Fig. 4.

polymer solutions, but that it is necessary to extrapolate the data to infinite dilution, when the molecular weight can be calculated by means of equation (12). Adair (*l.e.*) carried out his extrapolation for protein solutions by plotting  $\pi/c$  against  $c$ , but the statistical theory presented above suggests that the best plot would be  $\pi/c$  against  $c$ , and that this should be nearly linear. This method has been now generally adopted, although the most accurate data seem to indicate a slight curvature away from the  $c$  axis, as shown in Fig. 4. Where data are available for several solvents it is found that the extrapolated values of  $\pi/c$  agree within experimental error, although the slopes may be widely different. For a given solvent, the curves obtained with polymers differing only in molecular weight are nearly, if not exactly, parallel (*cf.* Fig. 4). The extrapolation is greatly facilitated if the dependence of  $\pi/c$  on  $c$  is small; it is usually possible to achieve this by a suitable choice of solvent or

by the use of a mixture of solvent and non-solvent (*cf.* Gee, *Trans. Faraday Soc.* 1940, 86, 1171). A useful guide to this choice is furnished by employing a solvent in which the polymer has a low intrinsic viscosity, and from which it is readily precipitated by addition of a non-solvent. In such a solvent  $\Delta H_0$  is large and the two terms in  $e_a$  (equation (II)) approximately cancel.

**G. a**

OSONES (v. Vol. n, 293c).

OSTWALD DILUTION LAW. The Ostwald Dilution Law (Ostwald, *Z. physikal. Chem.* 1888, 2, 36) expresses the application of the Law of Mass Action to the reversible ionisation of a weak electrolyte, and is usually expressed in the form:

$$a^2C/(1-a) = K \quad (1)$$

where  $K$  is the "classical" ionisation, or dissociation, constant and  $a$  is the degree of dissociation. If this is obtained by means of the Arrhenius expression  $v = AfA_0$  (Arrhenius, *ibid.* 1887, i, 6&1), where  $A$  and  $A_0$  are the equivalent conductivities at concentration  $C$  and zero, respectively, the equation becomes:

$$A^2C/A_0(A_0 - A) \sim K \quad (2)$$

which can be rearranged in the form:

$$AC = (1/A)A_0^2K - A_0K \quad (3)$$

from which it can be seen that a plot of  $AC$  against  $1/A$  should be a straight line. Tests of the equation with conductivity data on weak acids and bases yield a satisfactory degree of agreement with experiment, although systematic deviations are found, the more marked the stronger the electrolyte.

These deviations are explained by the modern theory of electrolyte and are due to two factors which are, in part, mutually cancelling in their effect. The first of these factors is the variation of ionic mobility with ionic strength (*see* ONSAOEB EQUATION, this Vol., p. 94c), so that the true degree of dissociation is given, not by the Arrhenius expression, but by  $a = A_jA_x$ , where  $A_x$  is the sum of the ionic mobilities at the concentration to which the value of  $A$  relates.  $A_x$  may be calculated by means of the Onsager equation (*l.e.*) or by reference to conductivity data for relevant strong electrolytes, use being made of the Kohlrausch law of independent migration of ions. Thus, for a weak acid, HA,

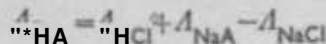

where the various  $A$  values all relate to the same ionic concentrations as  $A_H$ .

The second factor is the failure of the Law of Mass Action when the equilibrium quotient is expressed in terms of concentrations. The law holds rigidly only when the concentrations are converted to activities by multiplying them by the proper activity coefficients. Since it is impossible separately to evaluate individual ionic activity coefficients, and since in dilute solutions the activity coefficient of an un-ionised solute may be taken as unity within a dose limit,

accuracy/ the Ostwald Dilution Law expressed in the form:

f\_{\pm}(C\_i/C\_u) = K \dots (4)

where f\_{\pm} is the mean ionic activity coefficient, C\_i = C(Af/x) is the true ionic concentration and C\_u = C - C\_i is the concentration of unionised solute, is the most accurate representation of mass-action law available for weak electrolytes in dilute solution. Values of the mean ionic activity coefficient may be obtained by means of the Debye-Hückel activity equation (Debye and Hückel, Physikal. Z. 1923,24,185) which, in its simplest form, is -log f\_{\pm} = A \sqrt{C\_i}/C\_i, where A is a constant, which, for a uni-univalent electrolyte in water at 25°c, has the value 0.5056.

This modification of the Dilution Law provides the means for the determination of true thermodynamic dissociation constants, the equation:

log K = log K' - A \sqrt{C\_i} \dots (5)

where K' = C\_i \* C\_u, being applied, usually graphically. Information is required as to the value of A\_0 (or of values of A) and this is obtainable, in the case of the study of the strengths of weak acids, from conductivity measurements on solutions of the sodium salts. In certain cases, however, these independent data may not be available, and it is then necessary to solve the conductivity data on the weak electrolyte directly for K. Various methods have been proposed for this purpose, based on the assumption that in very dilute solution the conductivity is completely defined by the Ostwald Dilution Law, the Onsager ionic mobility equation, and the Debye-Hückel activity equation (Fuoss and Strauss, J. Amer. Chem. Soc. 1933, 55, 476; Fuoss, J. Amer. Chem. Soc. 1935, 57, 488; Ives, J.C.S. 1933, 731; 1943, 511; Shedlovsky and Vblig, J. Gen. Physiol. 1934, 17, 649; Shedlovsky, J. Franklin Inst. 1938, 225, 739).

The extension of the modified Dilution Law to solutions stronger than about 0.01 molar is not facilitated by the use of extended forms of the Onsager or Debye-Hückel equations because of the intervention of "medium effects," due to the accumulation of unionised solute in the solution. This appreciably modifies its electrical and other physical properties.

D. J. G. I. Carinate of cadmium, and (Cd 61.5%) isomorphous with calcite, one of the two minerals containing cadmium as an essential constituent (v. GBEEN, VOL VI, 136d). I\* forms white to reddish white crusts of minute curved rhombohedra with a brilliant lustre. It is found in small amount, together with greenockite, cerussite, etc., lining cavities of the oxidation zone of the deposits of copper and silver in the west Africa (Ramdohr, Strunz, Zentr. Min. 1941, A, 97).

L. J. S. QUABAGENIN, QUABAIN, QUABAIO TREE (v. Vol. II, 386a). OVERPOTENTIAL. When an ionic species is discharged at an electrode at an appreciable rate, the electrode potential may be displaced from the reversible value observed

with no current flowing. In such a case the electrode is said to be polarised and to exhibit an overpotential or overvoltage. The total overpotential is defined as the potential difference between such a working electrode and a similar reversible electrode in the same solution. It may be made up of contributions from two distinct effects:

(a) A potential difference due to changes in concentration of the ionic species near the electrode as a result of electrolysis; this is usually referred to as concentration polarisation.

(b) A potential difference due to thermodynamic irreversibility in the electrode process; this is the factor generally implied when the term overpotential is used without qualification, and it is sometimes distinguished as activation overpotential.

CONCENTRATION POLARISATION.

Owing to the discharge of ions at a working electrode, their concentration in the solution immediately adjacent to the electrode tends to diminish. This tendency is opposed by the bringing up of ions to the electrode by diffusion, convection, and migration, and a steady state is eventually reached when a concentration gradient has been established and the ionic concentration at the electrode surface has an equilibrium value (C\_e) less than the value (C) in the bulk of the solution. As a result, according to the Nernst equation, the reversible potential of the working electrode is changed by an amount:

i = nRT/F \log(C/C\_e) \dots (1)

where n is the valency of the ion concerned, and R, T, and F have their usual significance. As the reference electrode is usually situated at such a distance as not to be affected by these local concentration changes, r\_{ij} will be included in the measured total potential difference and constitutes the concentration polarisation or concentration overpotential.

Concentration polarisation is liable to occur with all electrode processes. Its magnitude and dependence on experimental variables are best considered by reference to the concept of the diffusion layer. It may be supposed, as a first approximation, that the working electrode is covered by a layer of solution of definite thickness across which there exists a linear concentration gradient, and within which convection is negligible. Application of Fick's Law to the diffusion of the relevant ionic species of diffusion coefficient D gives:

Rate of diffusion in g.-ions per day

= AD(C - C\_e) / l \dots (2)

where a is the thickness of the layer, A its area (equal to the area of the electrode), and C and C\_e are the boundary concentrations in g.-ions per c.c. If i is the current density in amp. per sq. cm., it follows that on equating the rate of discharge of the ions to the quantity of electricity passed per second, the relation:

AD(C - C\_e) / l = iA \dots (3)

is obtained, and this on simplification gives:

$$D(C-C_e)nlS=0.895I \quad . \quad . \quad (4)$$

whence:

$$C_e=C-0.895I/Dn \quad . \quad . \quad (5)$$

Substitution of this value in equation (1) gives the relation

$$V_o=\pm T \ln F) \log_e \{1-(0.895/DnC)\} \quad (6)$$

From equation (6) it is immediately apparent that concentration polarisation will be minimised by a high diffusion coefficient, valency, and bulk concentration of ion concerned, whereas its magnitude will be increased by a high current density (CD.) and conditions which favour a thick diffusion layer. In an unstirred solution at room temperature for a given set of conditions  $\delta$  appears to have a fairly constant value of some 0.02-0.05 cm.; it is decreased appreciably by rise of temperature and very considerably by agitation, and both these factors therefore tend to reduce concentration overpotential. It is seen from equation (6) that for a given set of conditions, there exists a limiting value of  $I$  at which the concentration overpotential may become infinitely large when the second term in the bracket approaches unity. This is termed the *limiting CD.* for the process considered, and corresponds to a state of affairs in which  $C_e$  at the electrode surface approaches zero; further increase of CD. will then cause the potential to change to such a value that another electrode process can occur. From equation (6) it is apparent that the limiting CD. is given by the relation:

$$I_{lim.} = DC_e / 0.895 \quad . \quad . \quad (7)$$

and if  $\delta$  is given the common value of 0.05 cm., this reduces to  $I_{lim.} = 22.3ZC_e$  for an unstirred solution at room temperature. In the above discussion, the migration of the ionic species to the electrode has been ignored, and the argument therefore only applies strictly to a solution in which the bulk of the current is carried by other indifferent ions. Where this is not so, the conclusions reached will still apply in a general way, but the migration of the ions which are discharged will tend to reduce concentration polarisation and the onset of limiting current conditions will be less sharply defined.

With concentrated well-stirred solutions of simple salts, concentration overpotential is usually very small except at extremely high CD's., and in general it may be said that up to CD's., of the order of one-tenth of the limiting value for any given set of conditions, concentration overpotential will be less than 1 centivolt. If, however, the substance to be liberated at the electrode is present in the solution as a complex ion in equilibrium with a very low concentration of simple ion, the latter being discharged, the position is rather different. In this case the limiting CD., which is controlled by diffusion of the complex ion, may be quite high, but the electrode potential is governed by the minute concentration of simple ion, and this may be markedly affected by electrolysis even at very

low CD's., particularly if the dissociation of the complex ion is slow; hence considerable concentration polarisation may develop at relatively low CD's. Abnormal concentration polarisation of this kind is frequently observed in the electro-deposition of metals from cyanide solutions (c/. Foerster, Z. Elektrochem. 1907, 13, 561; Glasstone, J. CS. 1929, 690, 702).

#### ACTIVATION OVERPOTENTIAL.

The discharge of most ions in electrolysis occurs reversibly, and any overpotential exhibited is limited to the concentration polarisation discussed above. In a relatively few cases, however, there appears to be some irreversibility inherent in the electrode process, and the discharge potential may be widely different from the reversible value. The main reactions in which this is conspicuously shown are: the cathodic liberation of Hydrogen, the anodic evolution of oxygen, and the electrodeposition of nickel, iron, and cobalt. Of these, the cathodic liberation of hydrogen has been most closely investigated and will be considered at some length.

#### HYDROGEN OVERPOTENTIAL.

History.—Early observations on the potentials at which hydrogen is liberated at cathodes were made by Pirani (Ann. Phys. Chem. 1884, [iii], 21, 68) and Le Blanc (Z. physikal. Chem. 1891, 8, 299), but the subject was first systematically studied by Caspari (*ibid.* 1899, 30, 89). He noted the potentials at which visible hydrogen evolution first occurred for a number of cathodes in dilute sulphuric acid, and found that in all cases these were more negative than the reversible hydrogen potential; the difference between the potential at which gas evolution was first observed and the reversible value he termed the "Oberspannung *oder* overpotential of the electrode, and he found it to be very markedly dependent on the nature of the cathode material, varying from about 0.003 v. for platinised platinum to 0.78 v. for mercury. Tafel (*ibid.* 1905, 50, 641) developed the concept of overpotential by measuring the difference of potential between a reversible hydrogen electrode and a cathode at which hydrogen was being liberated at a definite CD., and this convention has been adopted in nearly all later work. It is improbable that the potential at which visible gas evolution commences has any fundamental significance, since it will depend upon incidental experimental factors; for a time it was characterised as the "minimum" overpotential, but the utility of the concept is doubtful and it has gradually been abandoned. Since the work of Tafel, some scores of investigations of hydrogen overpotential have been made, and the subject, both on the experimental and theoretical sides, is one of considerable complexity and controversy.

Measurement.—Hydrogen overpotential is usually determined by measuring the potential difference between a cathode, which is being polarised at a constant CD. in a well-buffered solution, and a reversible hydrogen or other reference electrode immersed in or connected electrolytically to the same solution. At low

C.D.'s elaborate precautions must be taken to remove oxygen or other cathodic depolarisers which may be present in the solution (for general technique, see Baars, Sitzungsber. Ges. Befdrd. Naturwiss, Marburg, 1928, 63, 213); at CD's, of  $10^{-3}$  amp. per sq. cm. and upwards the effect of dissolved oxygen is generally negligible (Hickling and Salt, Trans. Faraday Soc. 1941, 37, 319). The overpotential is usually found to change with time, and some convention must be adopted in this respect; in some recent work, the steady values ultimately attained on prolonged electrolysis have been taken. Two different general methods of measuring the potential difference have been employed, the direct method and the commutator method. In the direct method the e.m.f. of the combination of working and reference electrodes is measured while the polarising current is flowing, whilst in the commutator method the current is momentarily interrupted by mechanical or other means. The commutator method was introduced to eliminate any error which may be included in the measured potential difference due to ohmic drop of potential in the electrolyte between the working and reference electrodes. With suitable electrode arrangements, any such resistance error is probably negligible up to  $10^{-2}$  amp. per sq. cm., and provided allowance is made by extrapolation for the rapid decay of hydrogen overpotential on interruption of the current, both methods give closely similar results at low C.D.'s. At high C.D.'s, the commutator methods usually give appreciably lower values of overpotential than are obtained by the direct method. (Considerable controversy exists as to the relative applicability of direct and commutator methods at high C.D.'s; for recent review papers and references to the extensive literature, see Hickling, *ibid.* 1937, 33, 1540; Ferguson, Trans. Electrochem. Soc. 1939, 76, 113.)

Considerable difficulty is encountered in obtaining reproducible values of overpotential at most cathodes, owing to uncontrollable variations in the surfaces of the electrodes. Published values have, therefore, a relative rather than an absolute significance, and it has not been possible to establish the influence of various factors.

The most striking feature of hydrogen overpotential is its marked dependence upon the nature of the electrode material; in general metals of low melting point have high overpotentials and vice versa. Below are given comparable values for a number of metals in 1N. hydrochloric acid at a C.D. of 1 milliamperes per sq. cm. at 18°C. (Hickling and Salt, Trans. Faraday Soc. 1940, 36, 1226).

Hg	104 v.	Ag	0.46 v.
Cd	0.99 v.	Fe	0.40 v.
Pb	0.91 v.	Ni	0.33 v.
Sn	0.85 v.	W	0.27 v.
Bi	0.69 v.	Pt	0.25 v.
Al	0.58 v.	Au	0.17 v.
Cu	0.50 v.	Platinised Pt.	0.01 v.

The physical state of the cathode surface is also important, a roughened electrode having a lower

overpotential than a smooth one of the same material and size.

Hydrogen overpotential increases slowly with rise of current density, and over a considerable range (ca.  $10^{-6}$  to  $10^{+3}$  amp. per sq. cm.) the connection is a logarithmic one and is usually expressed by Tafel's equation  $\eta = a + b \log i$ , where  $\eta$  is the overpotential,  $i$  the C.D., and  $a$  and  $b$  are constants depending on the nature of the cathode material and the temperature. For a number of metals  $b$  has a value of about 0.1 at room temperature, so that the overpotential increases, by approximately 0.1 v. for each tenfold increase in C.D.; but in general  $b$  shows wide variations, for instance from 0.02 for platinised platinum to about 0.3 for lead. (The value of  $b$  is of considerable theoretical importance; for lists of values and discussion of them, see Bowden and Agar, Chem. Soc. Annual Rep. 1938, 35, 90; Glasstone, *ibid.* 1937, 34, 107; N. K. Adam, "The Physics and Chemistry of Surfaces," Oxford, 1941, p. 325; Hickling and Salt, Trans. Faraday Soc. 1940, 36, 1234.) The investigation of overpotential at C.D.'s below  $10^{-8}$  amp. per sq. cm. is difficult, since the influence of minute amounts of depolarisers is very great, but it has been claimed that Tafel's equation holds for a mercury cathode down to  $10^{-10}$  amp. per sq. cm. (see Bowden and Agar, *l.c.*), while for catalytically active metals such as platinum- it has been suggested that there is a linear relation between  $\eta$  and  $i$  at very low C.D.'s (Butler and Armstrong, *ibid.* 1932, 28, 380; Volmer and Wick, Z. physikal. Chem. 1935, 172, 429). The study of overpotential at high C.D.'s, above  $10^{-3}$  amp. per sq. cm., involves many experimental difficulties. It has been claimed that Tafel's equation holds up to C.D.'s, of well over 1 amp. per sq. cm. (Kabanov, Acta Physicochim. U.B.S.S. 1936, 5, 193; see also Frumkin, *ibid.* 1943, 18, 23), but investigation by a modified commutator method suggests that at C.D.'s, of this order the overpotential tends in many cases to approach a specific constant value for each metal (Hickling and Salt, Trans. Faraday Soc. 1940, 36, 1226).

Tafel (*l.c.*) noted that the overpotential of most cathodes tends to rise with time of polarisation, and this has been confirmed by many subsequent workers. Mercury, tungsten, and platinised platinum give overpotentials which reach constant values within a very short time of the start of electrolysis; most common metals attain overpotential equilibrium within about 1 hour, but with platinum, palladium, and iron the potentials may increase for several hours; with electrodeposited metals these times are usually reduced. On very prolonged electrolysis, roughening of the cathodes may cause a decrease of hydrogen overpotential.

A large number of investigations of the effect of hydrogen-ion concentration on overpotential have been made (see, e.g., Tafel, *l.c.*; Glasstone, J. CS. 1924, 125, 2646; Sand, Grant, and Lloyd, *ibid.* 1927, 378; Bowden, Trans. Faraday Soc. 1928, 24, 473; Proc. Roy. Soc. 1929, A, 126, 107; Lloyd, Trans. Faraday Soc. 1929, 25, 525; Lewina and Zarinski, J. Phys. Chem. U.S.S.R. 1937, 9, 621; Iofa, Acta Physicochim. U.R.S.S. 1939, 10, 903; Hickling and Salt, Trans. Faraday



Soc. 1941, **37**, 333), and while the results are not completely satisfactory, the bulk of the evidence seems to indicate that in well-buffered solutions the overpotential is practically independent of the pH, provided this is not too high. The influence of the *nature of the solvent* on hydrogen overpotential has been investigated by measurements in methyl and ethyl alcohols, acetic acid, ethylene glycol, cyclohexanol, and liquid ammonia (Carrara, Z. physikal. Chem. 1909, **69**, 75; Swann and Edelmann, Trans. Electrochem. Soc. 1930, **58**, 75; Lewina and Silberfarb, Acta Physicochim. U.R.S.S., 1936, **4**, 275; Novoselski, J. Phys. Chem. U.S.S.R. 1938, **11**, 369; Pleskov, Acta Physicochim. U.R.S.S. 1939, **11**, 305; Hickling and Salt, Trans. Faraday Soc. 1941, **37**, 224); again the results are not in complete agreement, but in general it appears that the overpotential varies with CD in a manner similar to that observed in aqueous solution, and the absolute values of overpotential are not substantially different.

The influence of *temperature* on overpotential has not been investigated very fully, and the published results are often unreliable on account of changes in the electrode surface during the course of measurement. So far as the position can be summarised, it would appear that for high-overpotential metals such as mercury and lead the temperature coefficient is some  $-0.002$  to  $-0.003$  v. per degree, while for low-overpotential metals it is very much smaller (cf. Rideal, J. Amer. Chem. Soc. 1920, **42**, 94; Knobel and Joy, Trans. Electrochem. Soc. 1923, **44**, 443; Bircher and Harkins, J. Amer. Chem. Soc. 1923, **45**, 2897; Weftrip, J.C.S. 1924, **125**, 1112; Glasstone, *ibid.*, p. 2651; Harkins and Adams, J. Physical Chem. 1925, **29**, 205; Bowden, Proc. Roy. Soc. 1929, **A**, **126**, 107; Kobosew and Nekrassov, Z. Elektrochem. 1930, **36**, 529; Hickling and Salt, Trans. Faraday Soc. 1941, **37**, 333). Early experiments on the effect of *pressure* on hydrogen overpotential led to uncertain results, but recent work seems to indicate that overpotential decreases slightly with increase of pressure (see, e.g., Cassel and Krumbin, Z. physikal. Chem. 1935, **171**, 7; Schischkin *et al.*, Z. Elektrochem. 1934, **40**, 713, 724; 1936, **42**, 631, 693; Schmid and Stoll, *ibid.* 1941, **47**, 360).

*Catalytic poisons*, such as arsenious oxide, in general increase hydrogen overpotential (Volmer and Wick, Z. physikal. Chem. 1935, **172**, 429; von Naray-Szabó, Naturwiss. 1937, **25**, 12; Hickling and Salt, Trans. Faraday Soc. 1941, **37**, 333), and also does the presence of some *colloidal substances*, such as gelatin or gum arabic, which are often used as addition agents in electroplating baths (Marie, Compt. rend. 1908, **147**, 1400; Pring and Tainton, J.C.S. 1914, **105**, 710; Isgarischev and Berkman, Z. Elektrochem. 1922, **28**, 47; Westrip, J.C.S. 1924, **125**, 1112). Substances which affect the *surface tension* of water usually have some influence on overpotential, but no general relation has so far been deduced (see, e.g., Thiel and Breuning, Z. anorg. Chem. 1913, **83**, 329; Glasstone, Trans. Faraday Soc. 1925, **21**, 36; Onoda, Z. anorg. Chem. 1927, **165**, 93).

The *rate of attainment* of hydrogen over-

potential in the first fraction of a second after switching on the polarising current has been very fully investigated at a mercury cathode (Bowden and Rideal, Proc. Roy. Soc. 1928, **A**, **120**, 59; Baars, *I.e.*; Brandes, Z. physikal. Chem. 1929, **142**, 97; Erdey-Grúz and Volmer, *ibid.* 1930, **150**, 203; Erdey-Grúz and Kromrey, *ibid.* 1931, **157**, 213; Hickling, Trans. Faraday Soc. 1940, **36**, 364; Barclay and Butler, *ibid.* 1940, **36**, 128). It has been established that in this initial growth, the potential varies linearly with quantity of electricity passed. This seems to imply that the rate-determining process in the build-up is the charging of a double layer; recent measurements give an average value of about 20 microfarads per sq. cm. for the double layer capacity at a mercury cathode in pure acid solutions (see Bowden and Agar, *I.e.*). The *decay of hydrogen overpotential* on interruption of the polarising current has been studied by a number of investigators (see, *fig.*, Baars, *Jx.*; Armstrong and Butler, Trans. Faraday Soc. 1933, **29**, 1261; Ferguson, Trans. Electrochem. Soc. 1939, **76**, 113; Hickling and Salt, Trans. Faraday Soc. 1941, **37**, 450). Two distinct processes appear to be invoked in the decay. One, which becomes operative only at CD's, greater than  $10^{-3}$  amp. per sq. cm., leads to a rapid drop of potential in the first thousandth of a second, and depends primarily upon the polarising CD used. The second, which occurs at all CD's., leads to a slower decay of overpotential, and follows a course such that the overpotential ultimately becomes proportional to the logarithm of the time; when this state is reached the rate of decay depends solely upon the nature of the electrode material.

It has been reported that *superimposed alternating and high frequency currents decrease hydrogen overpotential* (see, e.g., Rothmund and Lessing, Ann. Physik, 1904, [v], **15**, 193; Bancroft, Trans. Electrochem. Soc. 1916, **29**, 309; Glasstone, J. Amer. Chem. Soc. 1925, **47**, 940; Harkins and Adams, *I.e.*; Halla, Z. Elektrochem. 1929, **35**, 838; this last paper gives very full references to the extensive literature). In the latter case, however, it has been shown that the effort is not primarily in the overpotential, but leads to an increase in the rate of diffusion of depolarisers to the cathode, with consequent diminution in the effective polarising CD (Glasstone and Reynolds, Trans. Faraday Soc. 1932, **28**, 582; 1933, **29**, 399).

*Measurements of the overpotential of deuterium* show that it is definitely higher than that of hydrogen under comparable conditions (Bowden and Kenyon, Nature, 1935, **135**, 105; Hryvovsky and Müller, Coll. Czech Chem. Comm. 1935, **7**, 281), and it is considered that this factor is operative in the separation of the isotopes by electrolysis. Any theory of hydrogen overpotential should therefore account for the separation coefficients at different cathodes, though it may be noted that there is no very obvious parallelism between these and the observed hydrogen overpotentials (Eucken and Bratzler, Z. physikal. Chem. 1935, **174**, 279).

*Theories of Hydrogen Overpotential.*—In spite of much investigation, there is no general agreement as to the origin and mechanism



of hydrogen overpotential. In passing from hydrogen ions in solution to ordinary gaseous hydrogen molecules a number of consecutive steps must occur. If any one of these steps is slow, it will cause the cathode to become polarised, and an overpotential is to be expected. Current theories suggest two alternative locations for this "bottleneck":

(a) The initial discharge of the hydrogen ion— process which also involves its dehydration or desolvation, probably

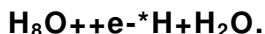

(b) The combination of atoms to give molecules

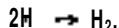

The idea that the discharge of an ion might be a slow process, initially suggested by A. Smits ('Theory of Allotropy,' *Los Gans*, 1922, p. 115; *Z. Elektrochem.* 1928, 80, 214), first attracted favourable attention when developed mathematically from different standpoints by Erdey-Gruz and Volmer (*Z. physikal. Chem.* 1930, 150, 203) and by Gurney (*Proc. Roy. Soc.* 1931, A, 134, 135) and it has been adopted in some form in the last few years by many workers. In general terms the view postulates that an energy barrier exists between the electrons in the cathode and the hydrogen ions to be discharged, and that for electrolysis to occur at an appreciable rate an excess potential or overpotential is therefore required. This fundamental idea has been developed in a variety of ways (see, e.g., Fowler, *Proc. Faraday Soc.* 1932, 28, 368; Butfir, *Proc. Roy. Soc.* 1936, A, 167, 101; Horiuti and Polanyi, *Acta Physico-Chim.* 1937, 7, 478; *J. Phys. Chem. U.S.S.R.* 1937, 10, 668; Hammett, *Trans. Faraday Soc.* 1933, 29, 770; Eyring, Glasstone, and Laidler, *Trans. Electrochem. Soc.* 1939, 76, 145; *J. Chem. Phys.* 1939, 7, 103) and the position clarified briefly it may be said that the theories based on it explain directly the fact that the initial growth of hydrogen overpotential is directly proportional to the quantity of a reaction passed, and the prediction of a relation between overpotential and current density the same form as Tafel's equation, *b* being given the value 23(2RT/F), i.e., 0.12 at room temperature, which is in approximate agreement with the values observed for a number of metals. The theories have not in general provided any detailed adequate explanation of the effect of other factors, such as the influence of electrode material, time, temperature, solvent, catalytic poisons, etc., and the initial postulates on which the theories are based have been adversely criticised. The alternative view, that the rate-determining step is the combination of hydrogen atoms to give molecules, appears to have originated with Tafel, and it is the amplest form of the theory since the rate of combination of hydrogen atoms to give molecules is relatively slow, there will be a minute pressure of atomic hydrogen at the working cathode, and from energy considerations it can be shown that this will give rise to a potential substantially more negative than the reversible hydrogen value, i.e., an overpotential will occur. Those metals which are good catalysts for the combination of hydrogen atoms might then be expected to show low overpotentials and vice versa, and indeed Bonhoeffer (*Z. physikal. Chem.* 1924, 113, 199) has shown experimentally that the order of increasing catalytic effectiveness for a number of metals is parallel to that of decreasing overpotential. Atomic hydrogen theories therefore start from a firm experimental basis, and they give plausible qualitative explanations of a wide range of cathode phenomena, e.g., influence of catalytic poisons, diffusion of cathodic hydrogen through metals, electrolytic reduction, etc., but early attempts to develop them quantitatively led to disappointing results; thus they gave an equation of the same form as Tafel's equation but with the low value of 2-3(HT/2F), i.e., 0.029 at room temperature, for *b*. New versions of the atomic hydrogen view have, however, been put forward in recent years in which attempts are made to allow for the undoubtedly complex gas-metal adsorption equilibrium at the electrode surface, and close quantitative agreement with experimental results has been claimed (see, e.g., Baars, *l.c.*; Kobosew and Nekrassov, *Z. Elektrochem.* 1930, 36, 529; Hickling and Salt, *Trans. Faraday Soc.* 1942, 33, 474).

will give rise to a potential substantially more negative than the reversible hydrogen value, i.e., an overpotential will occur. Those metals which are good catalysts for the combination of hydrogen atoms might then be expected to show low overpotentials and vice versa, and indeed Bonhoeffer (*Z. physikal. Chem.* 1924, 113, 199) has shown experimentally that the order of increasing catalytic effectiveness for a number of metals is parallel to that of decreasing overpotential. Atomic hydrogen theories therefore start from a firm experimental basis, and they give plausible qualitative explanations of a wide range of cathode phenomena, e.g., influence of catalytic poisons, diffusion of cathodic hydrogen through metals, electrolytic reduction, etc., but early attempts to develop them quantitatively led to disappointing results; thus they gave an equation of the same form as Tafel's equation but with the low value of 2-3(HT/2F), i.e., 0.029 at room temperature, for *b*. New versions of the atomic hydrogen view have, however, been put forward in recent years in which attempts are made to allow for the undoubtedly complex gas-metal adsorption equilibrium at the electrode surface, and close quantitative agreement with experimental results has been claimed (see, e.g., Baars, *l.c.*; Kobosew and Nekrassov, *Z. Elektrochem.* 1930, 36, 529; Hickling and Salt, *Trans. Faraday Soc.* 1942, 33, 474).

OXYGEN OVERPOTENTIAL.

Although a satisfactory, reversible oxygen electrode cannot be set up experimentally, its theoretical potential relative to hydrogen can be calculated thermodynamically. When this theoretical potential is compared with the actual one at which oxygen is being evolved at an anode, an overpotential, depending on the nature of the anode material, is invariably revealed. Thus Coehn and Osaka (*Z. anorg. Chem.* 1903, 34, 86) measured the potentials at which oxygen evolution commenced on a number of metallic anodes in N. potassium hydroxide solution against a reversible hydrogen electrode, and, taking the e.m.f. of the reversible hydrogen-oxygen cell as 1.22 v., their results give the oxygen overpotentials shown below.

Au . . . . .	0.53 v.	Cu . . . . .	0.26 v.
Pt . . . . .	0.45 v.	Fe . . . . .	0.25 v.
Pd . . . . .	0.43* v.	Platinised Pt .	0.25 v.
3: . . . . .	0.43 v.	Co . . . . .	0.14 v.
: . . . . .	0.41 v.	Ni . . . . .	0.13 v.
Pb . . . . .	0.31 v.	Spongy Ni .	0.06 v.

Data on the influence of experimental factors on oxygen overpotential are relatively few and of doubtful reliability owing to experimental difficulties, in particular the marked upward drift of overpotential with time of polarisation. From the limited observations which have been made (see, e.g., Foerster and Piguot, *Z. Elektrochem.* 1904, 10, 714; Westhaver, *t. physikal. Chem.* 1905, 51, 65; Foerster, *ibid.* 1909, 69, 236; Newbery, *J.C.S.* 1916, 109, 1066; Knobel, Caplan, and Eiseman, *Trans. Electrochem. Soc.* 1923, 43, 55; Bowden, *Proc. Roy. Soc.* 1929, A, 126, 107; Garrison and Lilly, *Trans. Electrochem. Soc.* 1934, 65, 275), it appears that oxygen

overpotential increases with rise of  $C.f.$ , and the relation may be similar to Tafel's equation for hydrogen overpotential, although this cannot yet be regarded as established. Increase of temperature decreases oxygen overpotential, the temperature coefficient at platinum being some  $-0.002$  to  $-0.004$  v. per degree. It has been reported that the overpotential is independent of hydrogen-ion concentration in acid solution, and decreases with increasing pH in alkaline solutions (Bowden and Agar, *I.e.*), but further investigation would seem to be desirable. The presence of fluorides definitely increase oxygen overpotential at unattackable anodes in both acid and alkaline solutions (Müller, *Z. Elektrochem.* 1904, **10**, 780; Isgarischev and Stepanov, *ibid.* 1924, **30**, 138). It has been stated that oxygen overpotential is reduced by superimposed alternating current (see, *e.g.*, Grube and Dulk, *ibid.* 1918, **24**, 237; Glasstone, *J. Amer. Chem. Soc.* 1925, **47**, 940), and by light and X-rays (Grube and Baumeister, *Z. Elektrochem.* 1924, **30**, 322; Bowden, *Trans. Faraday Soc.* 1931, **27**, 505; Duclaux, *Compt. rend.* 1935, **200**, 1838), but fuller investigation seems to be required before the exact significance of these results can be assessed.

As for hydrogen, current theories of oxygen overpotential fall into two categories, based on the alternative suggestions that the discharge of hydroxyl ions is a slow process requiring an energy of activation, or that oxygen arises through the intermediate formation of anodic products (*e.g.*, atomic oxygen, unstable oxides, etc.) which are considered to be electromotively more active than ordinary gaseous oxygen. Pending more thorough experimental investigations, such speculations would appear somewhat premature.

#### ELECTRODEPOSITION OVERPOTENTIALS.

If concentration polarisation is avoided, most metals are found to deposit from simple salt solutions at potentials very close to the reversible values. With the transition elements iron, cobalt, and nickel, however, substantial overpotentials are observed even at very low  $CD$ 's (Schweitzer, *Z. Elektrochem.* 1909, **15**, 602; Schildbach, *ibid.* 1910, **16**, 967; Foerster, *Abh. Bunsen-Ges.* 1909, No. 2; Glasstone, *J.C.S.* 1926, 2887; Foerster and Georgi, *Z. physikal. Chem., Bodenst. Festband*, 1931, 453). This is shown by the following figures comparing the reversible and deposition potentials of the three metals in N. solutions of their sulphates (Glasstone, *l.c.*).

	Reversible potential, v.	Deposition potential, v.		
		15°C.	55°C.	95°C.
Iron	-0.46	-0.68	-0.49	-0.46
Cobalt	-0.28	-0.56	-0.46	-0.36
Nickel	-0.23	-0.57	-0.43	<b>-0.29</b>

It is seen that the overpotentials are very considerably reduced by rise of temperature, and

this seems definitely to indicate that the polarisation is due to some slow, rate-determining stage in the electrode reaction. It has been suggested that this may be the initial discharge of the ions (see, *e.g.*, Foerster, *Z. Elektrochem.* 1916, **22**, 85; Thon, *Compt. rend.* 1933, **197**, 1312), the conversion of an unstable form of the metal initially deposited into the stable form (see, *e.g.*, Kohlschlüter, *Trans. Electrochem. Soc.* 1924, **45**, 229; Glasstone, *I.e.*), or the incorporation of the metal ions when discharged into the crystal lattice (Erdey-Grúz and Volmer, *Z. physikal. Chem.* 1931, **157**, 165; see also Hunt, *Trans. Electrochem. Soc.* 1934, **65**, 413); many of the theories attribute an important retarding effect to the hydrogen gas which usually accompanies the electrodeposition of these metals. In the present state of the subject it does not seem possible to reach a definite conclusion.

#### BIBLIOGRAPHY.

The literature concerning electrode polarisation phenomena is very extensive. For an account of early work with full references, see P. Foerster, "Elektrochemie wässriger Lösungen," Leipzig, 1922, Chap. IX. For recent reviews from different standpoints, see ff. K. Adam, "Physics and Chemistry of Surfaces," Oxford, 1941, Chap. VIII; Bowden and Agar, *Chem. Soc. Annual Rep.* 1938, **35**, 90; J. A. V. Butto, "Electrocapillarity," Methuen, 1940, Chaps. VI and VII; S. Glasstone, "Electrochemistry of Solutions," Methuen, 1937, Chaps. XVI-XIX.

A. E.

#### OXALIC ACID.

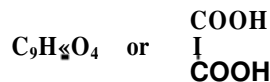

The mono-potassium salt of this acid occurs in many plants, *e.g.*, wood-sorrel, garden-rhubarb. The calcium salt is found in plants and urinary calculi, while the free acid is present in beet leaves and romney (*Polyporus ignarius*). Oxalic acid is also produced in the oxidation of carbohydrates by a large number of bacilli and by the action of many fungi and yeasts.

#### PREPARATION.

1. Boussan synthesised potassium oxalate by heating carbon dioxide with potassium hydroxide at  $80-200^\circ$ . (*Compt. rend.* 1905, **140**, 1209).
2. Sodium oxalate has been prepared by Dugan (U.S.P. 1232249) by spraying sodium into a pebble mill containing carbon dioxide at an elevated temperature.
3. Oxalates are obtained when formates of alkali metal salts are gently heated. The reaction is improved by heating in a partial vacuum to a temperature below  $360^\circ$  preferably about  $280^\circ$  (F.P. 381245; G.P. 204895; 269833). Sodium oxalate is also prepared by heating sodium formate with sodium carbonate at  $400-410^\circ$  or with preformed sodium oxalate at  $300-410^\circ$  (U.S.P. 714347). Yields up to 91% can be obtained in the production of oxalates from formates by heating the formate with less than 5% of an alkali hydroxide; hydrogen is evolved at  $290^\circ$  and the reaction is complete at double (P.P. 331498; U.S.P. 748791). By heating sodium formate with sodamide an 80% yield of

oxalate is obtained (Amer. Chem. Abstr. 1939, 33, 1661).

4. The formate method has been simplified by Peldkamp (U.S.P. 802980), who heated sodium hydroxide in a current of carbon monoxide and carbon dioxide (water gas or producer gas). The resulting mixture of sodium formate and sodium carbonate, on heating to a higher temperature, evolved hydrogen and gave a mixture of sodium oxalate and sodium carbonate.

5. Calcium oxalate is produced when a mixture of equal parts of sodium oxalate and lime is heated above 100° in the presence of carbon monoxide and water (Canad. P. 213376).

6. When sodium acetate, sodium hydroxide, and a copper salt are either fused or heated in water at 180-280° in the presence of oxygen sodium oxalate is formed (O.P. 561180).

An early process for the manufacture of oxalic acid consisted in the oxidation of organic matter with nitric acid. This is carried out in the laboratory by gradually adding 1 part of sugar or starch, heating the mixture to boiling, and evaporating to one-sixth the original volume. The crystals obtained on cooling are recrystallised from water. Ethylene glycol can be used in the place of sugar or starch (Seymour, J. Chem. Educ. 1939, 16, 285). A variety of different conditions and catalysts (e.g., vanadium pentoxide) have been described for the commercial production of oxalic acid by this process (G.P. 183022; U.S.P. 570733; B.P. 184627; U.S.P. 1446013; U.S.P. 173173).

Oxalates can be prepared by heating saw-wood with caustic soda. The best results are obtained with soft-wood sawdusts but many other materials have been used. Reduction of the wood with alkali gives a finer product. The process is proved by the introduction of an oxidising agent, such as hot steam, sodium peroxide or manganese dioxide, under reduced pressure, peroxide of manganese, potassium permanganate, nitrate of manganese, etc. Presence of magnesium salts, nitrates, nitrites, and air is not necessary (G.P. 277733; U.S.P. 170190; B.P. 373157).

The electrolysis of sodium cyanogen which, on absorbing chlorine acid, gives oxamic acid, can be hydrolysed to oxalic acid by the action of concentrated hydrochloric acid (Bucher, J. Ind. Eng. Chem. 1919, 11, 1000).

The action of oxalic acid on acetylene is described by Kearn, Heiser, and Newland, Amer. Chem. Soc. 1923, 45, 3368; Chem. Abstr. 1930, M, 3486 J; U.S.P. 1938, 2, 1000.

The species of oxalic acid produced in a medium from crude cane sugar is described by U.S.P. 1936, 2, 3081.

Oxalic acid is usually obtained from oxalates resulting from these processes by precipitation as the highly soluble calcium oxalate which is then decomposed with sulphuric acid.

The acid cannot be freed from oxalates by direct recrystallisation from water or organic solvents, but recrystallisation from 10 to 15% hydrochloric acid retains the cations as chlorides. Recrystallisation from alcohol containing a little sulphuric acid, then from water, gives the pure acid. This can also be obtained by sublimation of the crude material below 157° or by decomposition of methyl or ethyl oxalate with water. The anhydrous acid can be prepared from the crystalline hydrate by heating with carbon tetrachloride (Organic Syntheses, Coll. Vol. I, 1941, p. 421) or by drying in an oven at 98-99° for 2 hours (Organic Syntheses, 1930, 10, 78).

PROPERTIES.—Oxalic acid crystallises as monoclinic prisms containing 2 mol. of water. The hydrate, which melts at 101° on rapid heating, effloresces at 20° in dry air. The anhydrous acid melts at 189°. It dissolves in about 9 parts of water or 2½ parts of alcohol at room temperature and is slightly soluble in ether.

On heating at 150° the acid sublimes without decomposition, but at higher temperatures it decomposes, giving formic acid and carbon dioxide, or carbon monoxide, carbon dioxide, and water. On heating with concentrated sulphuric acid it gives carbon monoxide and carbon dioxide, whilst heating with alkalis causes decomposition to carbonate and hydrogen, the latter products also being formed when the anhydrous acid is heated with potassium or sodium.

An aqueous solution of oxalic acid under the influence of light and air decomposes into carbon dioxide, water and, in the presence of excess oxygen, hydrogen peroxide.

Oxalic acid is oxidised slowly with concentrated nitric acid and rapidly with permanganates, halogens, etc., to carbon dioxide and water. This property is utilised in the quantitative determination of oxalates or, alternatively, of oxidising agents, e.g., persulphates.

Oxalates are readily reduced with nascent hydrogen giving first glyoxylic acid and then glycollic acid.

Oxalyl Chloride, b.p. 64°, is produced when oxalic acid is treated with phosphorus pentachloride.

When ammonium oxalate is heated or when oxalic esters are heated with aqueous ammonia, oxamide (decomposes above 320°) is formed. Other important derivatives are the monoamide, oxamic acid, m.p. 210°; oxanilide m.p. 254°; and the mono-anilide, oxanilic acid, m.p. 149°.

DETECTION AND DETERMINATION.—When concentrated sulphuric acid is added carefully to a solution of oxalic acid containing a little resorcinol, a blue ring develops at the interface. Addition of a few drops of glycerol improves the test when the concentration of oxalic acid is very low (Brauer, Chem.-Ztg. 1920, 44, 494; Cheraoff, J. Amer. Chem. Soc. 1920, 42, 1784; Carletti, Amer. Chem. Abstr. 1937, 31, 2552).

An oxalate solution which produces a brown colour with methyl orange paper, on treating with fresh manganic hydroxide gives a red colour (Sacher, Chem.-Ztg. 1915, 39, 319; Lochmann, *ibid.* 1933, 57, 214).

Silver nitrate solution (20%) containing nitric acid gives a precipitate with oxalic acid but not with citric, malic, or tartaric acids.

Copper oxalate is insoluble in 30% sodium hydroxide solution.

Reduction of oxalic acid with zinc and sulphuric acid gives glycollic acid, which can be detected by the blue-green colour it generates on heating with concentrated sulphuric acid containing a little tannic acid, or by the pink colour given with 2:7-dihydroxynaphthalene. The latter can be used for the detection of 1  $\mu$ g. of oxalic acid (Egrieve, *Z. anal. Chem.* 1932, 89, 121; 1935, 100, 31).

A red colour is produced on treating oxalic acid with sodium vanadate solution and hydrogen peroxide (Ainsworth Mitchell, *Aniyst*, 1933, 58, 279).

A blue dye, soluble in alcohol, is formed when oxalic acid is fused with diphenylamine hydrochloride. Carbazole fusion gives a deep violet (Feigl and Frehden, *Mikrochem.* 1935, 18, 273; Augusti, *Chim. et Ind.* 1937, 37, 447).

Pesetz (*Bull. Soc. chim.* 1936, [v], 8, 2072), describes a test for oxalate in the presence of OCr, BrOS\ ClO<sup>i</sup>, NOS<sup>i</sup>, NO<sup>r</sup>, and CrOr<sup>r</sup>; 1 g. of pure zinc and 2 drops of 10% copper sulphate solution are added to a mixture of 5 c.c. of test solution and 1 c.c. of cooled 50% sulphuric acid. Four drops of the resulting glyoxal<sup>c</sup> acid solution are added to 2 c.c. of concentrated sulphuric acid containing two drops of 2% resorcinol in concentrated sulphuric acid. A pale blue colour develops in the cold, changing to intense blue on warming. Alternatively, a few drops of 1% phenylhydrazine hydrochloride are added to the glyoxylic acid solution, which is then heated almost to boiling, cooled, and an equal volume of concentrated hydrochloric acid and 5 drops of 5% K<sub>3</sub>Fe(CN)<sub>6</sub> added. A bright red colour develops. Iron if present interferes, and dilute H<sub>2</sub>O<sub>2</sub> is then used instead of K<sub>3</sub>Fe(CN)<sub>6</sub>.

Oxalic acid can be determined quantitatively by the following methods. The first two are generally used.

1. Titration with potassium permanganate. This is carried out in the presence of excess sulphuric acid at 70°, and can be used on the micro-scale (Kminek, *Amer. Chem. Abstr.* 1936, 30, 54; Renaudin, *J. Pharm. Chim.* 1936, 23, 447).

2. Gravimetric determination. The neutral oxalate solution is acidified with a few drops of acetic acid and calcium oxalate precipitated at the boil by the addition of calcium chloride. After standing 12 hours the precipitate is ignited at a dull red heat, a little ammonium carbonate solution added, and the residue reignited. The calcium carbonate formed can be weighed directly or converted to sulphate by adding dilute sulphuric acid and igniting. For the analysis of oxalate by calcium precipitation in the presence of citrate, tartrate, and malate, see Lindemann and Schnetka, *Z. anal. Chem.* 1934, 97, 1.

3. Iodometric. A dilute solution of oxalic acid and sulphuric acid is warmed with N/60 potassium iodate until iodine is liberated. Potassium iodide is added to the cooled solution,

which is titrated with 0.1 N thiosulphate. The titration can be followed potentiometrically (Singh and Singh, *J. Indian Chem. Soc.* 1939, 16, 343).

4. A neutral oxalate solution can be titrated with standardised lead acetate using fluorescein, eosin, Formyl Violet, Bromophenol Blue, or Bromocresol Blue as adsorption indicator (Wellings, *Trans. Faraday Soc.* 1932, 28, 565; Kocsis and Pollak, *Amer. Chem. Abstr.* 1935, 29, 1735). Lead nitrate can also be used with Chrorophenol Bed as indicator (Zombory and Pollak, *Z. anorg. Chem.* 1934, 217, 237).

5. Potentiometric with ferric chloride. A little ferrous sulphate is added at the start and the titration is carried out in an atmosphere of carbon dioxide using a platinum electrode, 1 Fe<sup>++</sup> = 1 (COO)<sub>2</sub><sup>-</sup> (Treadwell and Wettstein, *Helv. Chim. Acta*, 1935, 18, 981).

6. Titration with ceric sulphate. This can be carried out at 50° without an indicator, or an excess of ceric sulphate can be added then back-titrated with ferrous ammonium sulphate using N-phenylanthranilic acid ("ferroin") as indicator (see F. Pregl, "Quantitative Inorganic Analysis?" p. 382 (Longmans)). Titration at 35° with manganic sulphate is also satisfactory, *op. cit.*, p. 387.

7. Small amounts of oxalates in urine, etc., can be determined by acidification with hydrochloric acid followed by continuous ether extraction for 72 hours. After evaporation of ether the oxalic acid extracted can be determined by permanganate oxidation or calcium precipitation (Leulier and Dorche, *Bull. Soc. Chim. Biol.* 1938, 20, 939).

### Oxalates.

An extensive series of salts of oxalic acid exists, including normal oxalates, acid oxalates, double oxalates (mixed oxalates), and tetroxalates, which consist of 1 mol. of oxalic acid combined with 1 mol. of an acid oxalate. With the exception of those of the alkali metals, oxalates are almost insoluble in water.

*Potassium Oxalate*, C<sub>2</sub>O<sub>4</sub>K<sub>2</sub>·2H<sub>2</sub>O, crystallises in monoclinic prisms or pyramids and is readily soluble in water. *Potassium hydrogen oxalate*, C<sub>2</sub>O<sub>4</sub>HK, occurs either anhydrous as monoclinic prisms or as a monohydrate which is triclinic. It is found in the juices of plants, e.g., *Oxalis* and *Bumex*. The acid salt is much less soluble than the normal salt. *Potassium tetroxalate*, C<sub>2</sub>O<sub>4</sub>HK<sub>2</sub>·C<sub>2</sub>O<sub>4</sub>H<sub>2</sub>·2H<sub>2</sub>O, triclinic crystals, is formed from the acid salt and oxalic acid. Solutions of the acid salt tend to break up into the normal salt and the tetroxalate.

*Sodium Oxalate*, C<sub>2</sub>O<sub>4</sub>Na<sub>2</sub>, separates from hot solutions as a crystalline powder or fine, glistening needles. Both this and the acid salt are much less soluble than the potassium salts.

*Ammonium Oxalate*, C<sub>2</sub>O<sub>4</sub>(NH<sub>4</sub>)<sub>2</sub>·2H<sub>2</sub>O, occurs in Peruvian guano. It crystallises in long, rhombic prisms which occur as levo- and dextro-hemihedral crystals and are readily soluble in water. The acid salt is less soluble, crystallises in rhombic prisms, and gives a tetroxalate isomorphous with the potassium salt.

*Calcium Oxalate*,  $C_2O_4Ca, H_2O$ , occurs naturally. It is highly insoluble in water and is also insoluble in acetic acid. *Barium* and *strontium oxalate* are somewhat more soluble than the calcium salt.

*Ferrous Oxalate* occurs in lignite combined with  $UH_2O$  as *humboldtine*. It is obtained as a yellow powder containing  $2H_2O$  by mixing ferrous sulphate with oxalic acid or an oxalate.

*Ferric Oxalate*.—The normal salt is deposited slowly as a yellow precipitate on mixing normal oxalate with ferric chloride, or on treating freshly precipitated ferric hydroxide with a quantity of oxalic acid insufficient to dissolve the whole. *Sodium ferric oxalate*,

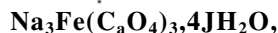

is obtained by dissolving ferric hydroxide in acid sodium oxalate solution.

"*Antimony Oxalate*.—The normal salt,



is prepared by-boiling antimonious chloride or oxychloride with oxalic acid or by mixing a saturated solution of oxalic acid with a hydrochloric acid solution of the trichloride. *Antimony potassium oxalate*,  $SbK_3(C_2O_4)_3, 6H_2O$ , forms Monoclinic crystals when a solution of antimonious acid is mixed with potassium oxalate. The sodium salt,  $SbNa_4(C_2O_4)_4, 10H_2O$ , is prepared similarly.

*Methyl Oxalate*,  $C_2O_4Me_2$ , is obtained by dissolving anhydrous oxalic acid in methanol (Organic Syntheses, Coll. Vol. II, p. 414). It crystallises in rhombic tables, m.p.  $54^\circ$ , b.p.  $163^\circ$ . It is converted into oxalic acid in methanol on boiling in water.

*Ethyl Oxalate*,  $C_2O_4Et_2$ , can be prepared by heating anhydrous oxalic acid with ethanol. The water formed during the reaction can be removed azeotropically (Wahl, Bull. Soc. chim. 1925, 27, 713). It boils at  $W^\circ$  and decomposes on boiling in water in the same way as methyl oxalate.

J. R.

**OXAZINE DYESTUFFS.** The oxazine dyestuff class comprises a relatively small class, closely related, as their name implies, to those of the azine series (Vol. 5, 565a, 668a, 5786) and thiazine (Vol. 6, 8). The first oxazine dye discovered by Meldola in 1879 (c/. Meldola's Blue) by condensing p-naphthol with nitrosodimethylamine hydrochloride; this reaction was extended by Koeberlin in 1881 and most of the important simple oxazine dyes were discovered between the date and 1908, the majority being discovered before 1900. No outstanding advances were made in more recent years. The triphenyl oxazine dyes made their appearance as direct cotton dyestuffs producing brilliant shades of extremely good light-fastness.

The direct oxazine dyes are mostly basic mordant dyes used mainly with tannin, iron, or chromium salt mordants to blue-violet shades. They are fast to light and have fastness properties except towards alkali. They are applied from neutral media and they have

found fairly wide application for calico printing as substitutes for the more expensive but faster vat blues; this applies particularly to the naphthophenoxazines (v. infra). They are reduced easily to oxidisable leuco-compounds which reform the dyestuffs more or less quantitatively on oxidation; they are not usually discharged by hydrosulphite and on this account they are used for producing coloured effects in calico printing; they can, however, be discharged, i.e., permanently bleached, by oxidising agents such as sodium chlorate and potassium ferricyanide. They can also be employed for dyeing leather, paper, and silk and as pigments and microscopical stains, but these uses are not important. By far the most important members of the series are the Gallocyanine dyes, which are employed not only on cotton, but also as chrome dyes for wool, particularly in the form of their sulphonic acids.

For the purpose of this article the oxazine dyestuffs are conveniently discussed under the following headings:

- (a) Simple diphenoxazine dyestuffs.
- (b) Naphthophenoxazine dyestuffs.
- (c) Gallocyanine dyestuffs.
- (d) Triphenyl oxazine dyestuffs.

(S) DIPHENOXAZINE DYESTUFFS.

These dyestuffs take their name from their reduced or leuco-forms, which are derivatives of phenoxazine, a very stable, colourless compound, m.p.  $148^\circ$ , obtained by heating o-aminophenol and catechol to  $260^\circ$  (Berntsen, Ber. 1887, 20, 943); the dyestuffs have the ortho- or para-quinonoid or phenoxazonium or phenoxazonium salt form represented by the generalised formulae below:

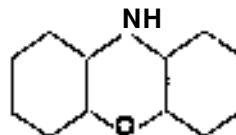

Phenoxazine.

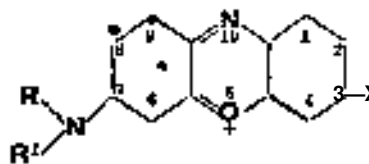

Phenoxazonium or o-quinonoid.

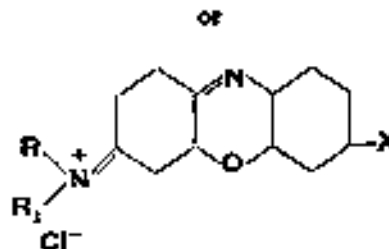

Phenoxazonium or p-quinonoid

In common with the azine dyes and the thiazine dyes, the oxazine dyes are now represented as being o-quinonoid phenazoxonium salts (*cf.* Kehrmann, *Annalen*, 1918, 414, 157) as distinct from the earlier views that they possessed a  $\xi$ -quinonoid structure (Kehrmann, *Ber.* 1899, 32, 2601) although it should perhaps be mentioned that a case can be made out for representing them as complex salts, which are best formulated on the Werner-Hantsch system (Fierz and Köchlin, *Helv. Chim. Acta*, 1918, 1, 216). On the modern idea that all such dyestuffs are resonant hybrids of several possible electronic forms, no particular canonical formula can be expected to be entirely satisfactory; however, the o-quinonoid formula above is most generally acceptable and explains satisfactorily all but the finer points in the behaviour of these compounds.

In all the important dyestuffs of this class the group in position 7\* is either an amino- or a dialkylamino-group and the group in position 3 is usually a similar group, hydrogen or hydroxyl.

Diphenoxazine dyestuffs are made by the following general methods (*cf.* A. Winther, "Patente der organischen Chemie," 1908, Giessen, Vol. II, p. 396).

1. By the interaction of a p-nitroso-derivative of an aromatic (dialkyl) amine or a phenol with an appropriate aminophenol, or by the interaction of a nitroso-compound of a ra-(dialkylamino)phenol with the appropriate amine; in this reaction 2 mol. of the nitroso-compound are employed, a second J mol. being necessary to oxidise the leuco-compound first formed to the dyestuff.

2. By the interaction of quinone dichlorodimide with m-(dialkylamino)phenols.

3. By the oxidation of mixtures of p-diamines and m-amino- or m-(dialkylamino)phenols, or of m-hydroxy-p-diamines and amines or by the direct oxidation of o-aminophenols, by such reagents as acid ferric chloride, dichromate, etc.

4. By the interaction of aminoazo-compounds from appropriate amines and m-aminophenols or polyphenols or the corresponding aminoazo-compound from m-aminophenol and the appropriate amine; in this reaction the arylazo-group functions like the nitroso-group in reaction 1.

The first method is by far the most important and the one invariably used where possible, the second method also gives good results in the laboratory but is liable to be rather violent.

The following are the more important diphenoxazine dyes, the numbers in parentheses being the reference number to the particular dyestuff in "The Colour Index," edited by F. M. Rowe, Bradford 1924.

Nitroso Blue MR (So. 907; Meister Lucius u. Bruning, B.P. 6056, 1898) was a mixture of nitrosodimethylaniline hydrochloride, resorcinol, and tannic acid which was used for padding

\* *Nomenclature.*—Several methods of numbering the oxazines have been proposed from time to time, but for complicated structures like dyestuffs, the most satisfactory is the one based on the Patterson System as given in Patterson and Capell, "The Ring Index," Beinholt Publishing Corp., New York, 1940.

cotton, or the separate components were used in calico printing, and during the process of ageing (steaming), the simple diphenoxazine dye in which R and R' = Me, and X = OH, was produced and gave an indigo-blue tannin lflke which was fixed in a tartar emetic bath.

Resorcine or Iris Blue (No. 908; Weselski and Benedikt, *Monatsh.* 1880, 1, 886), obtained by condensing resorcinol with nitrosoresorcinol and brominating the product, is of interest not as a basic dyestuff, but in connection with its relation to Lackmoid, the unbrominated compound, which has been used as an indicator for acids and alkalis.

Cresyl Blue 2RN and 2BS (No. 877; Leonhardt, B.P. 1390; 211§4, 1892) in which R and R' = Me or Et, X = NH<sub>2</sub> and a Me group is adjacent to the dialkylamino-group in the 8-position, is obtained by condensing the appropriate nitroso-m-dialkylamino-cresol with p-phenylenediamine!

Cap. i Blue GON (No., 876; Leonhardt, B.P. 13565; 18623', 1890) is the most important of the simple basic diphenoxazine dyes and is obtained by condensing p-nitrosodimethylaniline hydrochloride with m-diethylamino-p-cresol as follows;

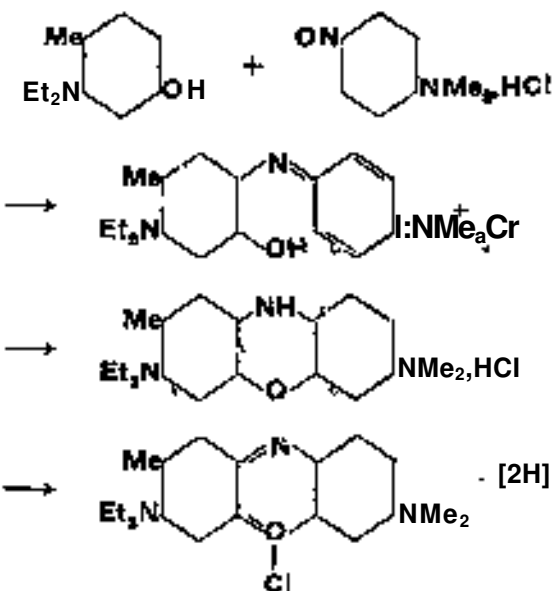

half of a second molecule of nitrosodimethylaniline being utilised to oxidise the leuco-compound to dyestuff, being itself reduced to dimethyl-p-phenylenediamine in the process.

The Capri Blues are still used to a very small extent for dyeing tannin and tartar emetic mordanted cotton in bright greenish-blue shades fast to light and washing, but these basic diphenoxazine dyes are more of historical and academic than of technical interest at the present time.

#### (b) NAPHTHOPHENOXAZINE DYESTUFFS.

The naphthophenoxazines are of greater technical interest than the Capri Blues.

Meldola's Blue (No. 909; Meldola, *Ber.* 1879, 12, 2066; *J.C.S.* 1881, 39, 37) is obtained

by heating an excess (2 mol.) of nitroBodimethyl-aniline hydrochloride with )8-naphthol in alcoholic solution, and lias the crastitution

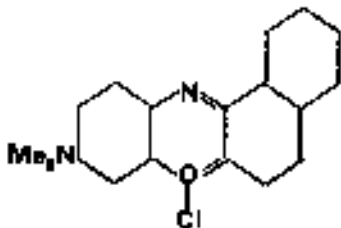

Its manufacture is an unpleasant operation as the dry dyestuff attacks the mucous membrane, but nevertheless it has been manufactured in large quantities and extensively used as a cheap substitute for indigo, although its importance is now declining. The hydrogen atom in the ex-position *para* to the ^azi&e nitrogen in Meldola's Blue is reactive, and the, dyestuff\* will interact with nitroso-compounds and with amines under oxidising" conditions to give the corresponding substituted amino-derivative in this ^position, and several dyestuffs are made from the parent dyestuff in this way. Thus, excess of nitrosodi-njethyl-aniline or dimethyl-^phenylenediamine S ^s New Blue B (S.C.I.) (No. 910; Hoffman and Weanberg, 1889), an impurity always present m Moldola's Blue, which dyes mordanted cotton m ~~the or and purer shades, but possesses the same~~ unpleasant properties, whilst dimethylamine gives New Methylene Blue GG (No. 911; B.P. 5840, 1890).

Nile Blue A (No. 913; Badische Anilin- u. Soda-Fabrik, B.P. 4476, 1889) and Nile Blue 2B (No. 914; Julius, B.P. 10619, 1891) prepared by condensing nitroso-m-diethylaminophanol hydrochloride with o-naphthylamine and Denzyl-a-naphthylamine, wsspectively, so that they carry NH<sub>2</sub> ana\* NHCH<sub>2</sub>Ph groups in the reactive o-positlon, dye cotton mordanted with tannin and tartar emetic in beautiful bright blue and greenish-blue shades and have for this reason enjoyed some technical importance.

In passing, it may be noted that Nile Blue A and New Methylene Blue GG are also of interest for colouring microscopical sections, nitrogenous matter being coloured blue, while neutral fat is stained bright red, the red colour being due to Partial hydrolysis of the dyestuff to the non-basic, red dimethylaminonaphthophanoxazone:

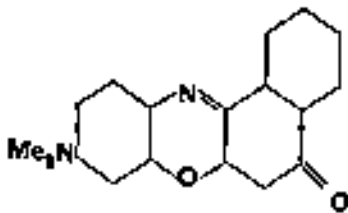

(cf. T. A. J. S. 1907, 91, 324) Ah ^ \* J. S. 1907, 91, 324) 917; B. M. D. I. 61\*? 1895 are also dina PTM; OXIZIN ^ lil ? - 1895 are also dina PTM; nanhli can 3 rir < adjacent OH groups in the i mporta en UCL EUS, butt W are not technically

(c) GALLOOYABTNES.

The gallocyanines are by far the most important members of the oxazine series and their discovery arose from attempts by H. Koechlin (B.P. 4899, 1881; Monit. Sci. 1883, [iii], 13, 292) to fix nitrosophenol on to cotton by steaming in presence of a tannic acid-tartar emetic mordant.

Gallocyanine (No. 883) is obtained by boiling nitrosodimethylaniline hydrochloride and gajlic acid in alcoholic solution and has the structure:

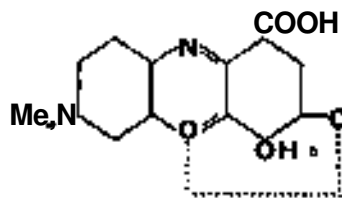

and Gallocyanine BS is the corresponding bisulphite compound. The importance of these dyes rests in their cheapness and in the fact that not only do they dye mordanted cotton, but also chrome-mordanted wool in bright navy shades of good depth and moderate fastness properties.

The most important dyestuff is Gallocyanine itself, but a very large number of derivatives are on the market, mainly as a result of the activities of the Swiss firm, Durand and Huguenin (Basle), which has made the development of this field its special care, and only the more important can be mentioned here.

Gallamine Blue (No. 894; Geigy, B.P. 2941, 1890) and the Gal lan i I Violets (No. 896; Soc. Ohim. Ind. Bâle, B.P. 11848, 1889) are made from gallamide, and gallanilide instead of gallic acid whilst methyl gallate affords Prune Pure (No. 893; Kern, B.P. 5953\* 1887).

Modern Violet (No. 892; Durand, Huguenin & Co., B.P. 21415, 1898) probably the next most important dyestuff to Gallocyanine is a reduction (leuco-) product of Gallamine Blue, Modern Violet N (No. 891) is the decarboxylated leuco-gallocyanine, and Coreine 2R (No. 800) is the dyestuff from gallamide and diethylaminoazobenzene hydrochloride.

Gallocyanine itself, the amide, and esters all contain a reactive position, probably adjacent to the carboxyl group, which readily undergoes substitution, and a very large number of new dyestuffs have been obtained by condensing the parent gallocyanines with amines, hydroxyl-compounds, etc.

Phenocyanine VS (No. 902; B.P. 24802, 1893) and Ultracyanine B (No. 901; Steiner, B.P. 6270, 1909) are derived from Gallocyanine and resercinol, Anthracyanine BGB (No. 884; Lorótan, B.P. 21949, 1906) and its congeners from the parent dye and dialkylamino-diamines, such as diethylamino-phenylenediamine, and Am i nogal lam i ne Blue (No. 895; De La Harpe and Burckhardt, B.P. 12067, 1908) from Gallamine Blue and ammonia, while Gallanil Blue (No. 897; Mohler and Meyer, B.P. 683, 1891) and Modern Azurine DH (No. 899; Zehntner and Oswald, B.P.



19001, 1907) are obtained by treating Gallanil Violet and Prune Pure with aniline.

A number of sulphonated galloxyanines are also important as chrome dyes for wool, including Galloxyanine MS (No. 885; Bierer, B.P. 10333, 1894) which is sulphonated galloxyanine, and Chromaz urine E (No. 879; De La Harpe and Bodmer, 1908; cf. G.P. 206465) obtained by treating Galloxyanine with aniline, removing the CO<sub>2</sub>H group, and sulphonating the product; this dyes chromed wool a shade approaching that of Methylene Blue. A similar product, Delphine Blue (No. 878; Hengenbach B.P. 569, 1890) is made by a slightly different process, and Brilliant Galloxyanine, Chromocyanine V, Blue PRC, and Rhine Blue (No. 888; De La Harpe and Vaucher, B.P. 6055, 1898) are produced by treating various Galloxyanines with aqueous sodium bisulphite in an autoclave.

### (3) TRIPHENDIOXAZINE DYES.

The development of the triphenioxazine dyes is the outstanding feature, as far as oxazine dyes are concerned, of modern times and has taken place almost entirely since about 1922. The technical method of making these dyestuffs was first disclosed in 1912 by Meister, Lucius, and Bruning (MLB) (cf. B.P. 8886, 1912) by submitting diarylaminoquinone, which are easily obtained by condensing p-benzoquinone with arylamines, to an oxidative ring-closure process either by heating the condensation products alone in high-boiling solvents like nitrobenzene, or by treating them with concentrated sulphuric acid or with dehydrogenation catalysts like aluminium chloride, ferric chloride, etc. In the technical application of this reaction di-chlorinated diarylaminoquinones, obtained by condensing the appropriate arylamine with chloranil, are usually employed, since they are cheaper to make than the non-halogenated compounds. In this first patent the product from chloranil and β-naphthylamine is boiled in nitrobenzene or treated

with aluminium chloride, or that from chloranil and o-anisidine is boiled in nitrobenzene with ferric chloride to give bluish-violet solids which afford soluble, bluish-violet dyestuffs on sulphonation.

This method of preparation of 6:13-dichlorotriphenioxazine from chloranil and aniline (also mentioned in the patent) may be taken as the simplest case and represented as follows:

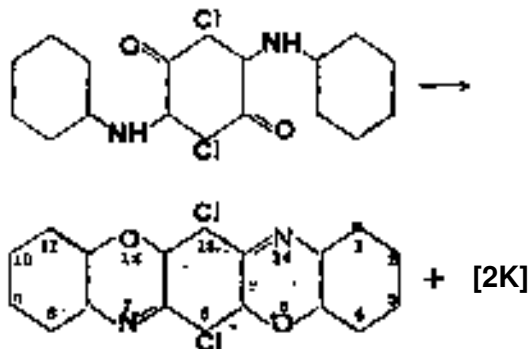

No further developments occurred until 1922-24 when Durand and Huguenin (DH) made the quinone dianilide from chloranil and β-amino salicylic acid and ring-closed it with sulphuric acid (B.P. 197940; 223481). In 1928, the I.G. took up the exploitation of this type of dyestuff and from then onwards a very extensive series of patents, starting with B.P. 313094, has appeared, in which more and more complex diarylaminoquinones have been made, ring-closed to the corresponding triphenioxazines and sulphonated to give direct dyestuffs for dyeing cotton in bright blue and blue-violet shades; those have reasonable fastness properties to washing and wet processing and outstanding fastness to light. It is probable that several of the newer blue direct-dyes for cotton of high light-fastness are sulphonated, complex, triphenioxazine derivatives and Sirius Brilliant Blue FFR (Kranzlein, Greune, and Thiele, B.P. 313094, 1928) is:

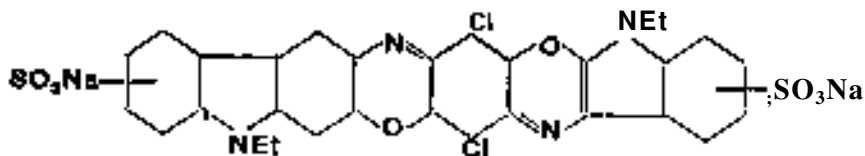

made by condensing chloranil with 3-amino-N-ethylcarbazole, ring-closing the product with boiling nitrobenzene and phosphorus pentachloride, and sulphonating the product (cf. Fierz-David, "Kunstliche organische Farbstoffe," Supplementary, Vol., 1935, Springer, Berlin, p. 17). A similar method of preparation which closely resembles the foregoing one and usually proceeds more smoothly because it does not involve an oxidation, was described in 1933 by Brunner and Thiess (B.P. 416887; see also Fierz-David, Brassel, and Probst, Helv. Chim. Acta, 1939, 22, 1348) and depends on the ring closure of diarylaminoquinones containing alkoxy-groups in the

o-position to the NH group in the arylamine radical:

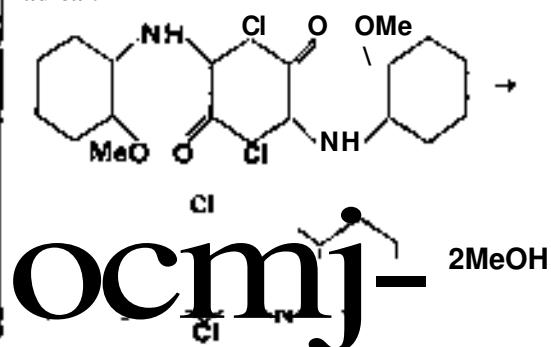

The agents used for promoting this type of ring-closure are aluminium chloride in pyridine, benzoyl chloride in boiling nitrobenzene <math>\text{C}\_6\text{H}\_5\text{NO}\_2</math> and concentrated sulphuric acid.

Various other methods of making triphendioxazines are to be found in the literature; none is of any technical importance, but the following are given for reference.

1. *o*-Aminophenols are readily oxidised to aminophenoxazones, e.g., by quinone, and under more drastic conditions, e.g., by heating to 150-160° in presence of hydrochloric acid, a second molecule of *o*-aminophenol reacts to give a triphendioxazine

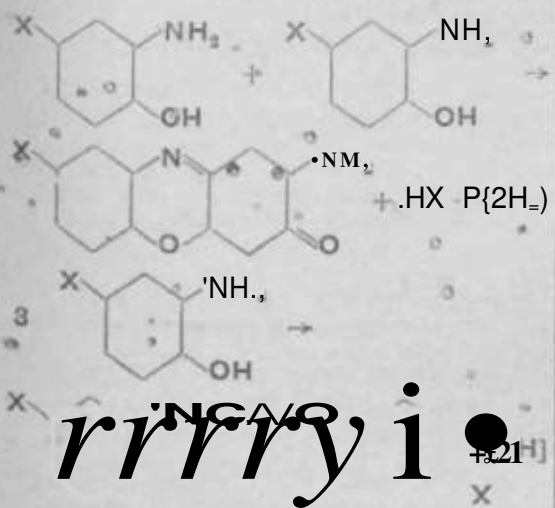

where, X=H, Cl, CO<sub>2</sub>H, etc.

In the case of nitro-2-aminophenol, no oxidation occurs, but condensation with halogenated benzoquinone gives nitrophenoxazones, which may be condensed with a further molecule of *o*-aminophenol to give a nitrotriphendioxazine (B.P. 411132).

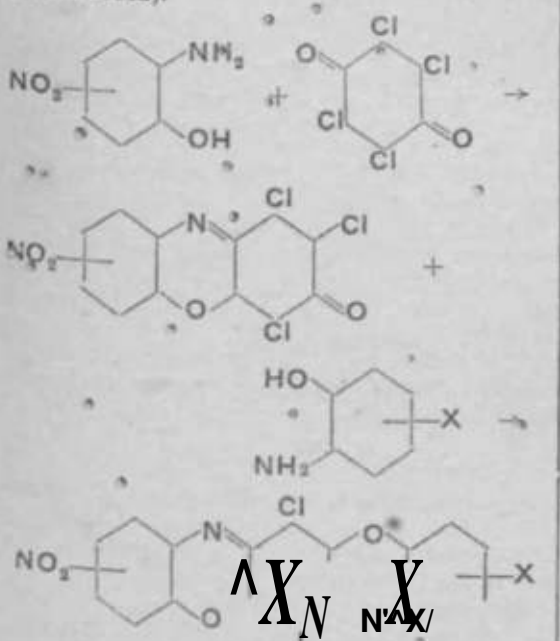

With groups, *o*-aminophenols containing two negative groups, *o*-aminophenol, Picramic acid, 5-nitro-3-aminosalicylic acid, the reaction takes a different course, giving

2:6 - dichloro - 3:6 - diarylaminoquinones which cyclise readily to dichlorotriphendioxazines in the usual way.

2. Triphendioxazine has also been obtained by the fusion of 4:6-dichlororesorcinol sulphate with 2 mol. of *o*-aminophenol (Seidel, Ber. 1800, 23, 182).

3. Kchrman and his co-workers (*cf. ibid.* 1893, 26, 2735; 1896, 29, 207(1); Helv. Chim. Acta, 1826, 9, 866; 1928, 11, 1028) have prepared a number of triphendioxazines by the condensation of dihydroxybenzoquinones with *o*-aminophenol. In the first stage of this reaction, the formation of hydroxyphenoxazone can be carried out in aqueous solution, but condensation of the latter with a further molecule of *o*-aminophenol frequently requires drastic conditions such as boiling in benzoic acid or anthracene.

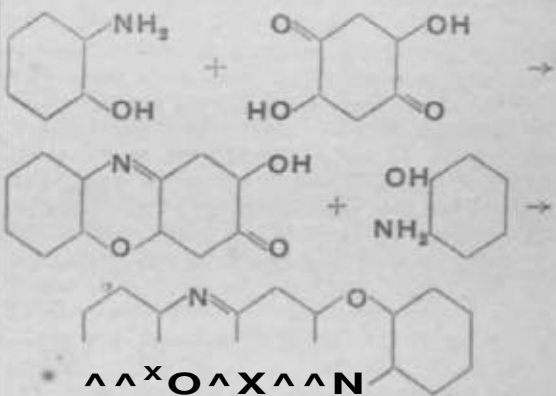

The halogenonitrophenoxazones from halogenated quinones and nitro-*o*-aminophenol, mentioned above, are more reactive than the hydroxyphenoxazones and condense with *o*-aminophenols in boiling ethanol or acetic acid.

The triphendioxazines are stable, inert, sparingly soluble substances. Triphendioxazine forms dark red crystals with a bluish cast subliming above 300° as a greenish-blue vapour; it possesses very weakly basic properties and forms a blue dihydrochloride in concentrated acid which is hydrolysed by water. It is unchanged by boiling alkali or chromic acid in boiling acetic acid, but can be reduced to a dihydro-compound ("leuco"), e.g., by heating with phenylhydrazine in ethylene or with zinc dust in aniline, and this regenerates triphendioxazine on re-oxidation. Triphendioxazine can be nitrated to give a crystalline nitro-compound (Seidel, *l.c.*). *Sil*-Dichlorotriphendioxazine is very reactive and when heated with aniline and aniline hydrochloride readily gives a trianilino-compound having the structure

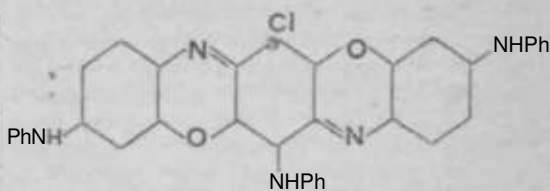

(*cf.* Fierz-David, Braseel, and Probst, *l.c.*)

The sulphonated dyestuffs are likewise very stable compounds, which are converted into

leuco-compounds by reducing agents, but are otherwise unchanged by aqueous, acid, or alkaline reagents.

*Literature.*—An adequate account of the phenoxazines, as distinct from dyestuffs derived from them, is given in V. Meyer and P. Jacobson, "Lehrbuch der organischen Chemie," Leipzig, Vol. II (3), pp. 1470-84. For further details on oxazine dyestuffs, reference may be made to the following:

- H. E. Fierz-David, "Kunstliche organische Farbstoffe," Springer, Berlin, 1926, pp. 351-367; Ergänzungsband, 1935, pp. 16-17.  
A. Winther, "Patente der organischen Chemie," Giessen, 1908, II, pp. 396-441.

The various summaries and reprints of German Patent Specifications in Friedlander's "Fortschritte der Teerfarbenfabrikation," Vols. 1-23, Springer, Berlin, 1940; Schultz, "Farbstofftabellen," Leipzig, 1931-39; and F. M. Howe *et al.*, "The Colour Index," Bradford, 1924.

**OXIDATION-REDUCTION POTENTIALS.** W. D. Bancroft (*Z. physikal. Chem.* 1892, 10, 387) was the first to observe that characteristic potentials were set up when platinum electrodes were immersed in solutions of a number of oxidising and reducing agents, whilst W. Ostwald in a paper on "The Chemometer" (*ibid.* 1894, 15, 399) showed from purely theoretical considerations that potentials established by oxidising and reducing agents at unattackable electrodes really constituted a measure of the oxidising or reducing power of the particular solution. The first step in the quantitative study of these potentials, however, was made by B. Peters (*ibid.* 1898, 26, 193) on the basis of the Van't Hoff Isotherm.

The difference in potential which exists between an inert electrode, such as one of platinum or gold, and a solution containing a compound in both its oxidised and reduced states, one or both being in the ionised form, is known as the oxidation-reduction potential, or more briefly "redox" potential. It happens, however, that no satisfactory method is known whereby the potential difference between a metal and a solution in which it is immersed can be measured, and in consequence, the potential has to be referred to, or compared with, the potential of a standard electrode or half-element, *e.g.*, saturated calomel, normal calomel, or decinormal calomel. These standard half-elements have been standardised against the normal hydrogen electrode, the potential of which is arbitrarily assumed to be zero. This is certainly not true, but such an assumption makes it possible to compare the "redox" potentials which oxidation-reduction systems set up in solution at an inert electrode, and at the same time these potentials provide a relative measure of the chemical intensity of any particular oxidation-reduction process.

The arbitrary zero electrode is that of a hydrogen electrode, supplied with hydrogen at exactly one atmosphere pressure, immersed in a solution containing one gram-molecule of hydrogen ions per litre. The hydrogen ions may originate from hydrochloric acid in solution, and the required concentration is computed from the relationship,  $ac=1$ , where  $a$  is the degree of ionisation, or conductance ratio  $A_c/A_0$  and  $c$  the number of g.-mol. of acid per litre, which on ionisation will provide 1 g.-mol. of hydrogen ions at the desired

temperature. In terms of the Lewis activity theory, the constitution of the arbitrary zero electrode (at 1 atm.) is modified thus: the hydrogen electrode (at 1 atm.) is immersed in a solution of hydrochloric acid the mean ionic activity of which is unity, *i.e.*  $(a_+a_-)^*=1$ . Although radically different, these two arbitrary zero electrodes differ in potential by approximately 0.003 v. at 25°C., and consequently "redox" potentials computed on the basis of the classical ionisation theory will normally be 0.003 v. more positive than they would have been if the activity theory had been employed.

Examples of oxidation-reduction systems fall into four categories:

1. *Oxidised and Reduced Metal Ions :*

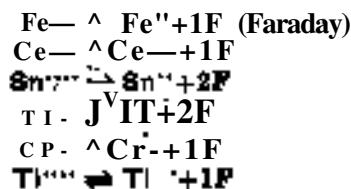

2. *Complex Anions :*



3. *Oxygenated Anions and Hydrogen Ions:*

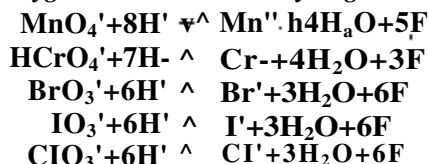

4. *"Organic" Systems: e.g.,*

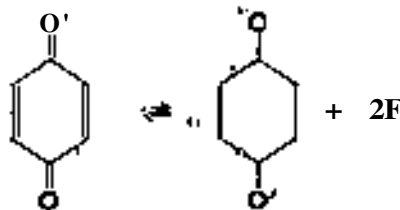

It has been tacitly assumed in giving these examples that the chemical symbols refer to gram-atoms (or g.-mol.) and that in proceeding from left to right the quantity of electricity liberated would therefore be equal to the number of faradays ( $zF$ ) indicated. This would actually occur at the cathode if the reductions were carried out electrolytically.

The reduction process is sometimes represented as being caused by the receipt of valency electrons by the oxidised form or forms, thus:

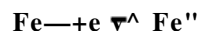

and  $\text{MnO}_4^- + 8\text{H}^+ + 5e \rightleftharpoons \text{Mn}^{++} + 4\text{H}_2\text{O}$ , where  $e$  represents the actual electronic charge and, in consequence, the symbols must refer to the actual ionised atoms or molecules.

The foregoing equations represent, at most, tendencies, as the reduction processes indicated by the upper arrows can only take place when the ion in its oxidised state is brought into contact with some other ion in its reduced state which is capable of being oxidised by the former. The following examples will show how

oxidising tendencies are converted into actualities in the course of well-known reactions:

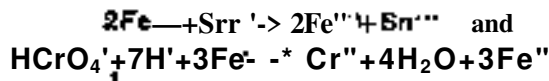

In the first case, to oxidise 1 g.-mol. of stannous ions it is necessary that they should receive 2F of electricity, i.e.,  $Sn^{2+} + 2F \rightarrow Sn^{4+}$ , which is obtained from the oxidising system, viz.,  $2Fe^{2+} \rightarrow 2Fe^{3+} + 2F$ , whereas in the second case the oxidising system

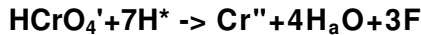

provides the necessary electricity, 3F, to oxidise 3Fe<sup>2+</sup>, thus

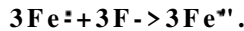

It now remains to ascertain why an oxidising agent, e.g.,  $K_2Cr_2O_7$  (in solution,  $KHCrO_4$ ) can oxidise certain ions, e.g.,  $Fe^{2+}$  and  $Sn^{2+}$ , and yet be able to oxidise  $Se^{2-}$  to  $Se^{4-}$ , and it is in this respect that the importance of "redox" potentials arise. With an oxidation-reduction system, e.g.,  $Fe^{3+} \rightarrow Fe^{2+} + F$ , there is to be associated an amount of free energy, (-AQ) which becomes available when the reduction is rendered possible. In electrical terms, this free energy must be equal to (quantity of electricity) X (potential difference), i.e.,  $-AG = (zF)xE$ , where # is the potential set up at an inert electrode when immersed in a solution containing the oxidised and reduced ions, and z is the decrease in positive valency or increase in negative valency between the oxidised and reduced states. If the free energy, -AQ, of the oxidising agent or system is greater than the free energy corresponding to that of the ions or molecules to be oxidised (considered as a reduction system), when oxidising and reducing agent are brought into the presence of one another, then oxidation will ensue until equilibrium is reached, which, if the difference between the two opposing free energies is considerable, will correspond with almost complete oxidation, whereas a small difference will lead to an incomplete oxidation. The free energy for the system:

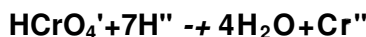

is equal to  $3F \times E_{HCrO_4^- / Cr^{3+}}$  and that of the system:

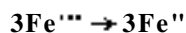

is equal to  $3F \times E_{Fe^{3+} / Fe^{2+}}$  so that if  $-AG_{HCrO_4^- \rightarrow Cr^{3+}}$  is greater than  $-AG_{3Fe^{2+} \rightarrow 3Fe^{3+}}$  i.e., if  $3F \times E_{HCrO_4^- \rightarrow Cr^{3+}}$  is greater than  $3F \times E_{Fe^{3+} \rightarrow Fe^{2+}}$  therefore, if

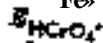

reduction will occur to a large extent depending on the magnitude of



The oxidation of  $Ce^{3+}$  ions is not possible with  $HCrO_4^-$  ions and  $H^+$  ions as  $E_{HCrO_4^-}$  is less than  $E_{Ce^{4+} / Ce^{3+}}$ .

The potential set up at a platinum or gold electrode when immersed in a solution containing the oxidised and reduced ions of any

particular system depends on (a) the concentrations of the oxidised and reduced states and any other ions that may play an integral part in the oxidation process, (b) the equilibrium constant at the particular temperature, and (c) the absolute temperature. For the system: Oxidised  $\rightleftharpoons$  Reduced + zF it follows from the Van't Hoff Isotherm, relating to the affinity of a reaction, that

$$-\Delta G = zF \cdot E_{Ox \rightarrow Red} = -RT \log_e \frac{[Reduced]}{[Oxidised]} = -RT \log_e \frac{[Reduced]}{[Oxidised]}$$

in which the square brackets represent the concentrations (g.-mol. per litre) of the forms enclosed, therein and [ ]<sub>f</sub> give the concentrations under true equilibrium conditions. Hence

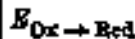

$$= (RT/zF) \log_e \frac{[Red]}{[Ox]} - (RT/zF) \log_e \frac{[Red]}{[Ox]}$$

$$= (RT/zF) \log_e K - (RT/zF) \log_e \frac{[Red]}{[Ox]}$$

$$= (RT/zF) \log_e K - \frac{0.001984T}{z} \log_{10} \frac{[Red]}{[Ox]}$$

$$= (RT/zF) \log_e K - \left( \frac{0.0591}{z} \right) \log_{10} \frac{[Red]}{[Ox]}$$

at 25°.

In view of the fact that the potential of the inert electrode,  $Ox \rightarrow Red$  is in practice referred to the potential of the normal hydrogen electrode, arbitrarily assumed to be zero, it is clear that the equilibrium constant, K, cannot be evaluated from measurements of  $E_{Ox \rightarrow Red}$  in a solution of which the concentrations [Red] and [Ox] are both known. The expression,  $(RT/zF) \log_e K$ , may, however, be easily evaluated, for it is the potential established when  $[Red] = [Ox]$  in the second term,

$$(RT/zF) \log_e \frac{[Red]}{[Ox]}$$

then is equal to  $(RT/zF) \log_e 1 = 0$ . The term

$$(RT/zF) \log_e \frac{[Red]}{[Ox]}$$

and is known as the normal or standard oxidation-reduction potential, or briefly standard redox potential. It thus corresponds with the potential established when a particular system is 50% in its oxidised state and 50% in its reduced state.

Applying the Isotherm to the various categories to which reference has been made, it follows at 25°c. that for:

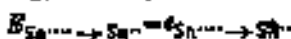

$$= \left( \frac{0.0591}{2} \right) \log_{10} \frac{[Sn^{4+}]}{[Sn^{2+}]}$$



$$= 0.0591 \log_{10} \frac{[Fe(CN)_6^{3-}]}{[Fe(CN)_6^{4-}]}$$

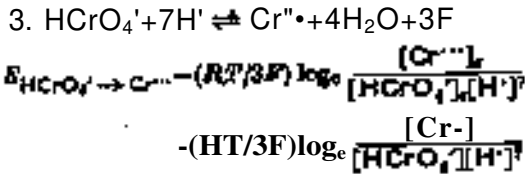

In this example, unlike the foregoing, hydrogen ions play an integral part in the reduction of the  $\text{HCrO}_4'$  ions, and they, therefore, must be included in the equation. Hence the term  $(RT/3F) \log_e K = e$ , the standard oxidation-reduction potential, is the potential  $\text{eA}$  up at a platinum electrode when  $[\text{Cr}^-] = [\text{HCrO}_4']$  and the concentration of hydrogen ions,  $[\text{H}']$ , is equal to 1 g.-mol. per litre, or in terms of activities, when  $\text{Cr}^- = \text{HCrO}_4'$  and  $\text{H} = 1$ . Hence

$$E_{\text{HCrO}_4' \rightarrow \text{Cr}''} = (RT/3F) \log_e \frac{[\text{Cr}'']}{[\text{HCrO}_4'] [\text{H}']^7} - (0.0591/3) \log_{10} \frac{[\text{Cr}^-]}{[\text{HCrO}_4'] [\text{H}']^7} + |x0-0591 \log_{10} [\text{H}']|,$$

from the last term of which it can be seen how great an influence the concentration (or activity) of hydrogen ions may have on the effective oxidation-reduction potential,  $\text{HCrO}_4' \rightarrow \text{Cr}''$ , and consequently on the efficiency of the  $\text{HCrO}_4'$  ion in promoting an oxidation chemically.

4. This system represents the reduction of quinone, Q, to the doubly charged anion,  $\text{Q}''$ , of hydroquinone, and, as the oxidised and reduced forms are isomeric,

$$E = (RT/2F) \log_e \frac{[\text{Q}'']}{[\text{Q}]} - (RT/2F) \log_e \frac{[\text{Q}'']}{[\text{Q}]} - (0.0591/2) \log_{10} \frac{[\text{Q}'']}{[\text{Q}]}$$

A difficulty arises in regard to  $[\text{Q}'']$ , which concentration is determined by the extents to which the very weak acid ionisations:

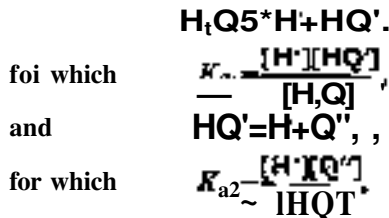

can occur, and this is largely dependent on the hydrogen ion concentration,  $[\text{H}^*]$ , of the solution itself. If the two constants,  $K_{a1}$  and  $K_{a2}$ , and the  $[\text{H}^*]$  and the total initial concentrations of hydroquinone and quinone are known,  $[\text{Q}'']$  can be computed by means of the equality  $[\text{Total hydroquinone}] = [\text{H}_2\text{Q}] + [\text{HQ}'] + [\text{Q}'']$ , and by incorporating the expression so obtained in the above potential equation, it follows that

$$E_{\text{Q} \rightarrow \text{Q}''} = (RT/2F) \log_e \frac{[\text{Q}'']}{[\text{Q}]} - (RT/2F) \log_e \frac{[\text{hydroquinone}]}{[\text{quinone}]} + (RT/2F) \log_e \{ [\text{H}']^2 + K_{a1} [\text{H}'] + K_{a1} K_{a2} \}$$

Owing to the fact that hydroquinone in alkaline solutions is oxidised by means of the air, this equation is applicable only to acid solutions, from about pH 0 to pH 8, when incidentally the last two terms in the last expression become negligible in comparison with the first,  $[\text{H}']^2$ . This, however, is not the case with other organic systems belonging to this category, e.g.,  $\alpha$ -naphthoquinone  $\beta$ -S-sulphonate.

The determination of oxidation-reduction potentials involves the setting-up of a cell which may be represented schematically thus:

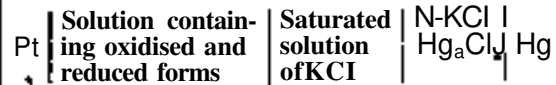

The platinum electrode, immersed in the "redox" system, constitutes one electrode, and the other is a standard half-element, such as the normal calomel electrode shown above. Between the two electrodes, or half-elements, a saturated solution of potassium chloride is inserted, in order to reduce the potential difference, which would be set up at the point where the two half-element solutions meet, to a minimum—in all probability to eliminate it entirely. The platinum electrode consists of a wire, or preferably a piece of foil of about 1 sq. cm., fused on to a platinum wire, the other end of which is sealed into the closed end of a piece of glass tubing, the latter being filled with clean dry mercury into which a copper wire, with an amalgamated end, dips. If it is desired to work at some specified temperature, then the whole cell should be placed in a thermostat. Ordinarily, this is unnecessary, for the potential of the standard half element with regard to the arbitrary hydrogen standard is known at different temperatures, and the effect due to temperature can be introduced in the calculation of the redox potential.

Bright platinum electrodes are usually satisfactory, although circumstances may sometimes arise when a covering with a thin deposit of platinum black may be an advantage.

The E.M.F. of the cell is measured by means of the ordinary Poggendorf potentiometer, which may be either the metre-bridge wire type or the commercially produced box type, in conjunction with a sensitive high-resistance D'Arsonval galvanometer or a capillary electrometer. If accurate E.M.F.'s are required the potentiometer will have to be standardised by means of a standard Weston cell. The principle of the method is to balance the E.M.F. of the test-cell against an opposed potential difference between two points on a uniform wire, the length of wire giving the balance being indicated by no deflection of the galvanometer which is placed in series with the test-cell. The potentiometer wire is supplied with a steady current from a 2-v. accumulator.

A point to remember in setting up the test-cell is to prevent contamination with potassium chloride of the solution undergoing test, by plugging the ends of the inverted U-tube with asbestos, glass wool, or sintered glass. Filter paper or cotton wool may sometimes be serviceable, but if these are used great care must be taken to ensure that they are not being attacked

by the redox system. This applies more particularly to strong oxidising agents, e.g., potassium permanganate.

If  $E_{redox}$  represents the potential difference set up at the platinum electrode and  $E_{standard}$  is the potential of the standard half-element used, then the observed E.M.F. is given by :

$$E.M.F. = E_{redox} - E_{standard}$$

$$= E_{redox} - (0.0001984T) \quad [Red]$$

$$- E_{standard}$$

In general, the platinum electrode is positive with respect to the standard electrode, and the above expression will apply, but in cases when  $E_{redox}$  is less than  $E_{standard}$ , then the E.M.F.  $E_{standard} - E_{redox}$ . The change in polarity will be readily observed from the fact that the test-cell connections will have to be reversed with respect to those of the (accumulator serving the potentiometer).

When  $E_{redox}$  becomes very low, there is a very real danger that the reduced form in the "redox system" being investigated will be oxidised by the air, and in such cases the electrode vessel employed must be closed and air prevented from gaining access to the solution by passing through the solution an inert gas such as nitrogen or carbon dioxide. This applies to solutions containing powerful reducing agents such as chromous, titanous, and stannous ions.

For most purposes, potential of the v. calomel electrode can be taken as +0.283 v. and that of the N. calomel electrode as +0.337 v. with respect to the normal hydrogen standard (see, however, H. T. S. Britton, "Hydrogen Ions," 3rd ed., London, 1934 Vol. I, pp. 66 et seq.).

Table I gives the E.M.F.'s obtained by P. H. T. at 17°C. of the cells:

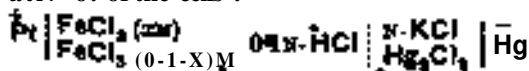

TABLE I.

[Fe <sup>2+</sup> ]	[Fe <sup>3+</sup> ]	ox 100	E.M.F.	$E_h$	$e_0$	$da/dE_h$
0.0995	0.0005	0.5	0.296	0.579	0.711	0.31
0.099	0.001	1	0.312	0.595	0.710	
0.098	0.002	2	0.331	0.614	0.711	0.59
0.090	0.010	10	0.375	0.658	0.713	
0.050	0.050	50	0.427	0.710	0.710	1.82
0.010	0.090	90	0.483	0.766	0.711	
0.001	0.099	99	0.534	0.817	0.702	7.69
						7.14

In these early determinations of Peters, a solution of potassium chloride was not interposed between the two solutions of the SPP electrodes. If, however, it be assumed that the liquid junction potentials were of negligible dimensions, (ii) the inclusion of 0.1N HCl completely repressed the hydrolysis of the ferric chlorides, (iii) the ratios of the concentrations of ferrous and ferric ions were proportional to the concentrations of the respective ions, it is possible to compute the

normal or standard reduction potential,  $e_0$  (column 6, Table I) by means of the equation:

$$E.M.F. = E_{redox} - E_{standard} - 0.283 = E_h$$

$$= e_0 - 0.0575 \log_{10} \frac{[Fe^{3+}]}{[Fe^{2+}]}$$

in which, as the potential of the N. calomel electrode is given with respect to the arbitrary hydrogen standard electrode ( $N-H=0$ ),  $E_h$  represents the actual redox potential set up by any particular "redox system" of ferric and ferrous ions. Column 3 gives the percentage of oxidised ions,  $Fe^{3+}$ , in each mixture,  $a$  being the fraction of the total iron ions in the ferric state. Table I shows that  $E_h$  increases with the degree of oxidation,  $a$ , and that  $E_h = e_0$  at 50% oxidation.

If  $E_h$  is plotted against  $a$ , it will be seen that between  $a=0.10$  and  $0.90$  the increase is almost rectilinear, but between  $a=0$  and  $0.1$  and also between  $a=0.9$  and  $1.0$  the increases are extremely rapid, in fact the equation indicates that when  $a=0$  and  $1.0$  the values of  $E_h$  are  $-\infty$  and  $+\infty$ , respectively. These values, of course, are never realised experimentally. For purposes of potentiometric titration with oxidising or reducing agents, it is sufficient to consider the  $E_h$  values corresponding to any redox system - [Red] 99, [Red] 1, i.e., between the initial  $E_h = e_0 - (RT/zF) 2.303 \log_{10} \frac{99}{1}$

$$= e_0 - 2x \frac{0.0001984T}{1}$$

and the final  $E_h = e_0 - (RT/zF)x 2.303 \log_{10} \frac{0.9}{1}$

$$= e_0 + 2x \frac{0.0001984T}{1}$$

In the case of the ferrous-ferric system at 17°C, this means that the effective oxidation-reduction range lies between  $E_h$

$$= e_0 - 2x 0.0575 \text{ v. and } E_h$$

$$= e_0 + 2x 0.0575 \text{ v.}$$

For the system:  $Sn^{4+} \rightleftharpoons Sn^{2+} + 2F$ ,  $E_h$  at 1% oxidation would be equal to  $e_0 - 0.0575$  v. and at 99% oxidation,  $E_h = e_0 + 0.0575$  v. at 17°C.

The dependence of  $E_h$  on the degree of oxidation,  $a$ , is known as the *poising action* of the "redox system." W. M. Clark has suggested that  $da/dE_h$  may be regarded as the *poising index*.

For the examples given in the first three categories:

$$E_h = e_0 - (RT/zF) \log_{10} \frac{1-a}{a}$$

where  $z$  is the difference in valency between the oxidised and reduced ions. Hence  $(da/dE_h) = (zF/RT) \frac{a(1-a)}{1-a}$ , thus giving the change,  $da$ , in  $a$ , which produces an increase,  $dE_h$ , in  $E_h$ , equal to 1 v. The expression shows the important influence which the valency change has on the poising index. The last column of Table I shows how the poising index varies with  $a$ , the poising being greatest between  $a=0.1$  and  $0.9$ .

Table II gives the values of  $e_0$  for a number of redox systems:

TABLE II.—NORMAL OXIDATION-REDUCTION POTENTIALS, IN VOLTS.

Co—*Co"	1.82
Pb—>Pb"	1.75
Mn <sup>+++</sup> ->Mn"	1.64
Mn <sub>4</sub> +4H <sup>+</sup> ->MnO <sub>2</sub> +2H <sub>2</sub> O	1.64
Cc <sup>+++</sup> ->C	1.60
Mn <sup>+++</sup> ->Mn"	1.58
MnO <sub>2</sub> +8H <sup>+</sup> ->Mn <sup>+++</sup> +4H <sub>2</sub> O	1.50
ClCV+6H <sup>+</sup> ->Cl'+3H <sub>2</sub> O	1.44
BFCV+6H <sup>+</sup> ->Br'+3H <sub>2</sub> O	1.42
HCrO <sub>4</sub> +7H <sup>+</sup> ->Cr+4H <sub>2</sub> O	1.30
Tl <sup>+++</sup> ->Tl	1.28
IO <sub>3</sub> <sup>-</sup> +6H <sup>+</sup> ->I <sub>2</sub> +3H <sub>2</sub> O	1.20
VO <sub>2</sub> <sup>+</sup> +2H <sup>+</sup> ->VO+H <sub>2</sub> O	1.00
NO <sub>3</sub> <sup>-</sup> +4H <sup>+</sup> ->NO+2H <sub>2</sub> O	0.95
2Hg <sup>++</sup> ->Hg <sub>2</sub> "	0.95
Fe <sup>+++</sup> ->Fe <sup>++</sup>	0.75
MnO <sub>4</sub> <sup>-</sup> ->MnO <sub>4</sub> "	0.66
H <sub>3</sub> AsO <sub>4</sub> +2H <sup>+</sup> ->HAsO <sub>2</sub> +H <sub>2</sub> O	0.61
Fe(CN) <sub>6</sub> <sup>+++</sup> ->Fe(CN) <sub>6</sub> <sup>++</sup>	0.44
Cu <sup>+++</sup> ->Cu <sup>+</sup>	0.16
Ti <sup>+++</sup> ->Ti	0.06
Sn <sup>+++</sup> ->Sn <sup>++</sup>	-0.15
Cr <sup>+++</sup> ->Cr <sup>++</sup>	-0.41

It will be noted that the oxidising agents appear at the head of the table and that the reduced forms of the systems shown at the foot of the table are the most efficient reducing agents. In general, the oxidised form of a system higher in the table will oxidise the reduced form of a system lower in the table, and *vice versa*, but whether the oxidation or reduction will proceed to completion will depend on the difference between the  $e_0$  of the two systems involved and the consequent possible overlapping of the  $E_h$  values corresponding to the oxidising system and the system undergoing oxidation. Another factor to consider, refers to systems involving hydrogen ions and the effect that their concentrations may have on the  $E_h$  values, which actually determine whether a system will be able to oxidise another or otherwise. Thus in the reaction:



the  $e_0$  of the oxidising system:



is +0.61 and that of the reducing system:  $I_2 + 2e \rightleftharpoons 2I^-$  is +0.62; in the presence of concentrated hydrochloric acid the reaction proceeds quantitatively in the direction of the top arrow whereas in solutions of pH 7-8 the reverse is the case.

In the foregoing example, reference was made to the system:  $I_2 \rightleftharpoons I^- + I^+$ . As this reaction involves iodine in the elemental state, the potentials set up at an iodine electrode are usually considered under the heading of electrode potentials; so are the potentials which exist between a metal, *e.g.*, copper, and a solution containing ions of that particular metal, *e.g.*,  $Cu^{++}$ . The electrode equilibrium is  $Cu^{++} \rightleftharpoons Cu + 2F$ , and the potentials set up are given by the ex-

pression  $E_h = e_0 + \frac{0.0001984T}{n} \log_{10}[M^{z+}]$  whereas in the case of non-metal, R, which enters into equilibrium with anions, *e.g.*, iodine, the potential  $E_h = e_0 - \frac{0.0001984T}{z} \log_{10}[R^-]$ , z being the valency of the ions,  $M^{z+}$  and  $R^{z-}$ . Strictly speaking, these electrode potentials are oxidation-reduction potentials and are compared with the N. hydrogen electrode standard in the same way as are the foregoing potentials. Table III gives some standard electrode potentials,  $e_0$ , i.e., potentials established at metal electrodes when immersed in solutions containing 1 g.-mol. of the respective ions per litre (or in which their activity  $a_{\pm}=1$ ).

TABLE III.

Air—*Au	+1.60T.
Au <sup>+++</sup> ->Au"	1.36
H <sub>2</sub> FeCl <sub>4</sub>	0.86
Hg <sub>2</sub> <sup>++</sup> ->2Hg	0.80
Ag <sup>+</sup> ->Ag	0.80
Tl <sup>+++</sup> ->Tl	0.72
Cu <sup>++</sup> ->Cu	0.51
Cu <sup>+</sup> ->Cu	0.34
Bi <sup>+++</sup> ->Bi	0.23
Sb—>Sb	0.1
Fe <sup>+++</sup> ->Fe	-0.4
Sn <sup>+++</sup> ->Sn	-0.10
Pb <sup>+++</sup> ->Pb	-0.12
Ni <sup>++</sup> ->Ni	-0.22
Zn <sup>++</sup> ->Zn	-0.76
Mg <sup>++</sup> ->Mg	-1.55
Na <sup>+</sup> ->Na	-2.71
Cl <sub>2</sub> ->Cl <sup>-</sup>	+1.36
Br <sub>2</sub> (aq.)->Br <sup>-</sup>	+1.09
I <sub>2</sub> ->I <sup>-</sup>	+0.62

Taking the potentials given in Tables II and III together, it is seen why a reducing agent such as titanous or chromous chloride deposits gold from an auric salt solution, silver from silver nitrate solutions, copper from copper sulphate solutions, and bismuth from bismuth salt solutions. The negative electrode potentials of the base metals, *e.g.*, tin, magnesium, and sodium, explain why they behave as powerful reducing agents.

Luther, in the so-called Luther's Rule, gives the relationship which exists between the standard redox potential of a system involving a particular metal in two ionised forms and the standard electrode potentials of that metal in equilibrium with one type of ion and also in equilibrium with the other type of ion. *E.g.*, consider the case of thallium. In the ionised form, we have the redox system (i)  $Tl^{+++} \rightleftharpoons Tl^{++} + 2F$  and we have also the two electrode systems:

- (ii)  $Tl \rightleftharpoons Tl^{++} + 2F$ ;
- (iii)  $Tl \rightleftharpoons Tl^{+++} + 3F$ ?

System (ii), involving the reduction of trivalent thallium ions,  $Tl^{+++}$ , to metallic thallium, might have been carried out in steps, first to  $Tl^{++}$  ions (i), and thence to metallic thallium, (iii). Clearly the free energy involved in the direct process,



(ii), must be equal to the sum of the free energies of the two steps (i) and (iii). Hence

$$-\Delta G_{(i)} = -\Delta G_{(ii)} - \Delta G_{(iii)}$$

$$3e_{T_1 \dots T_2} = 2e_{T_1 \dots T_2} + 1e_{T_1 \dots T_2}$$

whence  $3e_{T_1 \dots T_2} = 2e_{T_1 \dots T_2} + 1e_{T_1 \dots T_2}$

Substituting  $e_{T_1 \dots T_2} = 0.72$  v. and  $e_{T_1 \dots T_2} = 1.22$  v., it follows that  $e^{\wedge} y, -0.28$  v.

The Term rH.—This term was first introduced by Clark (U.S. Hyg. Lab., Bull. No. 151, 1928, p. 27) in order to express redox potentials in terms of the pH of the solution undergoing test and some function which would provide a measure of the actual oxidising intensity. This function was the term rH, but later Clark realised that this term did not always supply this measure and therefore advised that it should be withdrawn. Unfortunately, in some quarters, particularly industrial, the term was adopted and there appears to be every likelihood that it will be retained in use.

As the process operating at a hydrogen electrode, supplied with hydrogen at a pressure of 1 atm, is reversible, the potential of the



for which  $E_h = (2.303RT/F) \log_{10} ([H^+]/A/a)$  (see H. T. S. Britton, *op. cit.*, Vol. I, p. 19) Clark considered that the  $E_h$  of any redox system could be considered in terms of the hydrogen electrode at some appropriate pressure,  $T_1$ , and for this purpose he put  $-\log_{10} a = rH$ . Hence

$$E_A = (2.303RT/F) \log_{10} [H^+] - (2.303/2F) \log_{10} w \\ = (2.303RT/2F)(rH - 2pH) \\ = 0.00009922^T(rH - 2pH),$$

where  $w$  is the activity of the redox system in solution. This expression for the value rH could be directly derived from the observed  $E_A$ . By

$$rH = (E_A - E_h) / (2.303RT/2F)$$

and therefore rH would be the negative exponent to the base 10 of the pressure,  $w$ , at which the redox system would give the same potential as the hydrogen electrode at the same pressure. Clark had hoped that rH would therefore give a measure of the true redox intensity which was independent of pH, but in complicated organic systems this was not always the case. Thus in the reduction of quinone, Q, to the doubly charged anion of hydroquinone, Q<sup>2-</sup> (vide supra), we saw that

$$E_A = e' - (2.303RT/2F) \log_{10} \frac{[Hydroquinone]}{[Quinone]} + \phi[H^+]$$

where  $e' = e_{Q \rightarrow Q^{2-}} - (RT/2F) \log_{10} (K_{a1}K_{a2})$

$$\phi[H^+] = (RT/2F) \log_{10} \{ [H^+]^2 + K_{a1}[H^+] + K_{a1}K_{a2} \}$$

generally, for a comparable system

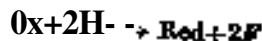

$$E_A = e' - (2.303RT/2F) \log_{10} \frac{[Red]}{[Ox]} + \phi[H^+]$$

By comparing this expression with the  $n$  hydrogen electrode expression, it follows that if  $[Red] = [Ox]$ , then  $e'$  would be equal to  $(-2.303/2F)rH$  and thus  $rH$  would supply a measure of the redox intensity as was originally believed by Clark. The complex form of  $\phi[H^+]$  shows it is not a simple linear relationship of pH as would be required if  $rH$  were to be of any material use. Where linear relationships hold  $rH$  is of importance and care should be taken to restrict its use only to such systems. To avoid confusion, it is better to give both the  $E_h$  and  $pH$  of the redox system, however.

Redox Indicators.—Many dyestuffs are known which have different colours in the oxidised and reduced forms and which constitute redox systems that are dependent on pH. Usually, their deductions obey the expressions

$$E_A = e' + \phi[H^+] - 0.00009922^T \log_{10} \frac{[Red]}{[Ox]}$$

so that when  $[H^+]$  is fixed,

$$E_A = e'' - 0.00009922^T \log_{10} \frac{[Red]}{[Ox]}$$

$e''$  being equal to  $e' + \phi[H^+]$ .

If  $a$ —fraction in the oxidised form, then  $b = 1 - a$ —fraction in the reduced form, and if the intensity of the colours of the oxidised and reduced forms are directly proportional to their respective concentrations, then as

$$e'' = e' - 0.029 \log_{10} \left( \frac{1-a}{a} \right) \text{ at } 18^\circ\text{C},$$

it is possible to calculate  $E_h$  corresponding to any particular colour. For values of  $e''$  at various pH values for an extensive series of redox indicators, see H. T. S. Britton, *op. cit.*, Vol. II, pp. 14-16; Clark *et al.* (U.S. Hyg. Lab., Bull. No. 151, 1928) and L. S. Hewitt ("Oxidation-Reduction Potentials in Bacteriology and Biochemistry," London County Council, 1937).

A practical use of a redox indicator is that of Methylene Blue in the so-called Schardinger test in testing milk (v. Vol. VIII, 1066).

A number of "redox indicators" have also been applied to the detection of end-points in oxidation-reduction volumetric titrations, but owing to their changing colour at high  $E_A$  values nearly all, except diphenylamine and its derivatives, can only be used with titrants having high redox-potentials, e.g., with ceric sulphate. The  $E_h$  at which diphenylamine changes colour is +0.76. In order to use it as an internal indicator in the titration of a ferrous solution with potassium dichromate in acid solution, it is essential to insert in the solution some reagent, e.g., phosphoric acid or ammonium fluoride, which, in forming complexes with the ferric ions, removes them from the sphere of action and so keeps the redox potential of the  $Fe^{3+} \rightleftharpoons Fe^{2+}$  system below +0.76.

H. T. S. B.

OXIDISING ENZYMES. Oxidising enzymes consist of the catalytic agents of the living cell that are responsible for the activation of substances which, in presence of the cell, undergo oxidation or reduction. They are

usually classified in two large groups, one group embracing the enzymes that control reactions in which molecular oxygen (or hydrogen peroxide) is (so far as is known) the sole oxidising agent, and a second group that comprises all enzymes which bring about reactions in which the oxidising agent is a substance other than oxygen or hydrogen peroxide. Enzymes of the first group are known as aerobic oxidases; those of the second group are referred to as anaerobic oxidases or dehydrogenases. All reactions, controlled by oxidising enzymes, proceed, in the absence of such enzymes, either slowly or at rates which are not measurable under the conditions of temperature or hydrogen ion concentration which prevail during the growth of the cell. The oxidising enzyme activates its substrates so that these undergo, under biological conditions, oxidations or reductions at rates very much greater than those which obtain in absence of the enzyme.

The great majority of reactions which are involved in cell respiration, or in the anaerobic changes which make up cell glycolysis and fermentation (see FERMENTATION, Vol. V, *Sd*; GLYCOLYSIS, Vol. VI, 73d), are brought about by oxidising enzymes. These are also sometimes referred to as respiratory enzymes.

The following is a brief description of the general properties of dehydrogenases and aerobic oxidases. The subject of biological oxidations is now a very large one, and a detailed account of the properties of oxidising enzymes and the systems in which they are involved is not possible in an article such as this. The reader is referred, for more complete details, to the various volumes of Annual Reviews of Biochemistry, Ergebnisse der Enzymforschung, and Advances in Enzymology, and to such books as C. Oppenheimer, "Die Ferments and ihre Wirkungen," 5th ed., Leipzig, 1925 *el seq.*; J. B. S. Haldane, "Enzymes," London, 1930; J. B. Sumner and G. F. Somers, "Chemistry and Methods of Enzymes," New York, 1943.

### DEHYDROGENASES.

Dehydrogenases have been often defined as enzymes which activate the hydrogen of metabolites. This definition is derived from the Wieland hypothesis (1912) that before a substance can be oxidised through the agency of an enzyme, hydrogen atoms of the substance must be made labile, or become activated. The labile hydrogen is transferred, in presence of the enzyme, to another substance such as a dyestuff. The substance whose hydrogen atoms become activated by an enzyme was known as a hydrogen donor, and the substance which undergoes reduction became known as a hydrogen acceptor. The enzyme responsible for the activation of the hydrogen atoms was defined as a hydrogen transportase, or more familiarly as a dehydrogenase. Thunberg<sup>61</sup> studied dehydrogenases of muscle using Methylene Blue as a hydrogen acceptor. Ehrlich had already found that a variety of living tissues including muscle, bacteria, and yeasts will reduce dyestuffs such as Methylene Blue. Thunberg showed that muscle tissue which reduces Methylene Blue under

anaerobic conditions will not do so at an appreciable rate when the tissue is washed. Reduction, however, takes place when substances such as sodium succinate, sodium lactate, sodium malate, sodium nitrate, etc., are added to the washed tissue (Thunberg<sup>61</sup>).

These substances are affected by specific dehydrogenases so that they become capable of reducing Methylene Blue and other hydrogen acceptors under anaerobic conditions.

This work by Thunberg was followed by that of Quastel and his colleagues<sup>60, 53, 54, 55</sup> on the dehydrogenases of bacteria. Work with washed suspensions of bacteria (known also as resting or non-proliferating bacteria) greatly extended the knowledge of dehydrogenases and of the manner in which they take part in the oxidising system of the living cell.

Equilibrium in Presence of Dehydrogenases.—Quastel and Whetham<sup>63</sup> were the first to show that a reversible equilibrium between sodium succinate, sodium fumarate, Methylene Blue and leuco-Methylene Blue exists in presence of succinic dehydrogenase of bacteria. Thunberg<sup>62</sup> then found that the same equilibrium point is obtained in presence of succinic dehydrogenase of muscle. Later studies made it clear that the equilibrium point was always the same whatever the source of enzyme and whatever method was used to arrive at the equilibrium point. Moreover the equilibrium point was identical with that deduced from thermodynamic data. These results are shown in Table I.

TABLE I.

[Succinate] - Dyestuff  
\*\* [Fumarate] & Leuco-dyestuff.

Thermal data:

[Succinate] - [Fumarate] -  $\Delta H + 2(e)$   
-  $J(7^* = -20,450 \text{ calories } (25^\circ\text{C}.)$

Experimental data:

Source or enzyme.	Method used.	$-\Delta G(25^\circ)$ calculated* from observed equilibrium point.	Investigators.
Heating B. coli.	Colorimetric.	-20,180	Quastel and Whetham. <sup>53</sup>
Horse skeletal muscle.	"	-19,140	Thunberg. <sup>61</sup>
"	Potentiometric.	-20,100	Thunberg. <sup>61</sup>
"	"	-20,180°	Lehmann. <sup>41</sup>
Beef heart	"	-20,140	Borsook and Schott. <sup>5</sup>
Beef diaphragm.	"	-20,140	"

\*  $\Delta G = \text{Free energy change.}$

This discovery led to the finding by Wurmser and his colleagues of an equilibrium between sodium lactate and sodium pyruvate in presence of lactic dehydrogenase. It was then discovered that reversible equilibria exist in presence of the majority of dehydrogenases. Examples of these are shown in Table II. It is thus apparent that a characteristic feature of a dehydrogenase is the existence in the presence of the enzyme of an equilibrium between the reduced and oxidised

TABLE II.

	'^Investigators.*
Ethyl alcohol ^Acetaldehyde + 2H i-p-Hydroxybutyric acid ^Acetoacetic acid + 2H i-a-Hydroxyglutaric acid ^a-Ketoglutaric acid + 2H woPropyl alcohol ^Acetone + 2H J-Malic acid v* Oxalacetic acid + 2H Lactic acid ** Pyruvic acid + 2H Succinic acid ^ Fumaric acid + 2H Hypoxanthine ^ Xanthine + 2H ^ Uric acid + 2H	Lehmann. <sup>4^</sup> Green, Dewan, and Leloir. <sup>20</sup> WeU-Malherbe. <sup>68</sup> Wurmser and Wurm-Ber. <sup>TM</sup> Lak. <sup>**</sup> Wurmser and Mayer-Reich. <sup>69</sup> Quastel and Whet-ham. <sup>53</sup> Green. <sup>1</sup> Green. <sup>1</sup>

forms of its substrate {e.g., succinate and fumarate, or lactate and pyruvate, etc.} The equilibria, brought about by dehydrogenases are essential for the accomplishment of the cyclic processes which determine the course of respiratory metabolism of the living cell.

**Specificity of Dehydrogenases.**—The demonstration that succinate and fumarate form a reversible equilibrium in presence of a dehydrogenase showed for the first time that both succinate and fumarate are activated by the same enzyme. Wieland's concept of hydrogen activation could not be correct, for this would not explain why a dehydrogenase should activate fumarate as a hydrogen acceptor. Thus it became clear that the enzyme activates not the hydrogen but the entire molecule of the substrate so that this becomes a hydrogen donor or acceptor according to the structure of the molecule {see Quastel<sup>60</sup>}.

The dehydrogenases are either completely specific, i.e., they activate only the reduced and oxidised forms of their substrate, or they have a narrow range of specificity. Thus succinic dehydrogenase has little or no activating power on the homologues of succinic and fumaric acid—malonic, glutaric, and glutaconic acids; there seems to be a feeble activating action on pyruvic, mesaconic, and citraconic acids. Lactic dehydrogenase definitely activates o-hydroxybutyric acid but less powerfully than lactic acid, it has, however, no activating action on p-hydroxybutyric acid. The dehydrogenase which acts on pyruvic acid and acetoacetic acid has no action on lactic and pyruvic acids. The enzyme responsible for the oxidation of formate to carbon dioxide in anaerobic bacteria exerts its effect solely upon this acid. Choline dehydrogenase brings about the oxidation of choline

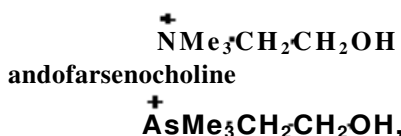

the corresponding aldehydes being formed, but it has no effect on nicotinic acid or on ethyl alcohol. Alcohol dehydrogenase activates methyl, ethyl, propyl, and butyl

alcohols, but it does not affect glycerol or a-glycerophosphoric acid. Glucose dehydrogenase seems to activate only glucose. a-Glycerophosphate dehydrogenase has no action on the unnatural optical isomer of a-glycerophosphate or upon o-glycerophosphate. Malic dehydrogenase affects d(+)-malic acid to a lesser extent than l(-)-malic acid; it appears to attack no other substrates, apart from oxalacetic acid.

**Inhibitors of Dehydrogenases.**—In general, molecules similar in structure to a substrate may compete reversibly with the substrate for an enzyme, although they may not be activated or undergo chemical change. This competition brings about an inhibition of the enzyme's activity with the substrate (Quastel and Woolridge<sup>54</sup>). Thus with lactic dehydrogenase the following molecules when mixed with lactate strongly inhibit its velocity of oxidation:

- CH<sub>2</sub>(OH)COOH;
- COOHCOOH;
- CHOCOOH;
- COOHCH(OH)COOH;
- CH<sub>2</sub>OH·CH(OH)COOH;
- EtCH(OH)COOH;
- Ph·CH(OH)COOH;
- MeCOCOOH.

The structure —CO·COOH or —CH(OH)COOH

seems to be common to all molecules competing with lactic acid for the enzyme, and would appear, therefore, to be necessary for the attachment of a molecule to the dehydrogenase.

With succinic dehydrogenase, the following molecules compete with succinic acid for the enzyme:

- COOH·CH<sub>2</sub>·COOH;
- CC(OH)·CH<sub>2</sub>·CH<sub>2</sub>·CH<sub>a</sub>·COOH;
- PhCH<sub>2</sub>CH<sub>a</sub>COOH;
- CH<sub>2</sub>(COOH)CH(COOH)CH<sub>2</sub>COOH;
- COOHCHMeCH<sub>2</sub>COOH;
- COOHCOCH<sub>a</sub>COOH.

The structure in the substrates necessary for attachment to the enzyme appears to be

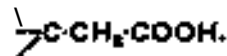

Apparently, however, the presence of a second acid group increases greatly the affinity of the molecule for the enzyme. The competition between (say) malonate and succinate for the succinic dehydrogenase obeys the mass action law. The high affinity of malonate for succinic dehydrogenase has made malonate a very useful tool in the exploration of cell metabolism; for by means of malonate it is possible to suppress succinate oxidation in the living cell and to discover by the changes in cell metabolism the part played by succinate oxidation in cell respiration and fermentation. At the same time malonate inhibition of succinic dehydrogenase indicates how a reversible enzyme inhibition may suppress or

poison cell respiration (and in consequence cell development).

Molecules which combine with succinic dehydrogenase have little or no affinity for lactic dehydrogenase and *vice versa*. Xanthine dehydrogenase, which activates xanthine, hypoxanthine, 6:8-dihydroxypurine and 2-thioxanthine, is inhibited by guanine, uric acid, 3-methylxanthine, 1-methylguanine, 7-methylguanine, and 1:7-dimethylguanine. But 1:3-dimethylxanthine, theobromine, and caffeine have little or no inhibitory effect (Coombs\*). The purine nucleus appears to be necessary for union with the enzyme, the combination being furthered by amino groups and retarded by methyl groups. Amine oxidase (*vide infra*) is reversibly inhibited by phenylwopropylamine ("benzedrine") and its derivatives. The combination of the amines (and of the wopropylamine which are not activated with amine oxidase) obeys the laws of mass action (Mann and Quastel<sup>46</sup>). The structure necessary for attachment to amine oxidase seems to be -CH(R)NR<sub>2</sub> where R=H or alkyl. With diamine oxidase two basic groups in the substrate would appear to be necessary for attachment to the enzyme.

Lactic dehydrogenase is inhibited by small quantities of pyruvate, whilst malic dehydrogenase is inhibited by both pyruvate and oxalacetate. Succinic dehydrogenase is inhibited by oxalacetate.

The inhibitive effects of cyanide, pyrophosphate, and iodoacetate on some dehydrogenases are shown in Table III.

TABLE III.

Dehydrogenase.	% Inhibitions by		
	HCN (0.002M).	Pyro- phosphate (0.0211).	Iodo- acetate (0.0031).
Succinic . . . .	0	75	0
Lactic . . . . .	0	0	0
Alcohol . . . . .	0	0	92
Xanthine . . . .	100	0	0
a-Glycerophos- phoric . . . . .	0	0	0

Arsenites and sodium fluoride show general toxicity to dehydrogenases at relatively high concentrations.

Certain dehydrogenases require -SH groups for their activities and reagents which immobilise such thiol groups inhibit the dehydrogenases. Oxidised glutathione inactivates succinic dehydrogenase,<sup>37</sup> and the activity may be restored by treatment with reduced glutathione. A variety of reagents such as alloxan, maleic acid, and copper-sulphate inhibit succinic dehydrogenase under conditions where they will not inhibit lactic, malic, and o-glycerophosphoric dehydrogenases. These inhibitions are alleviated by treatment with reagents which restore the thiol group of the enzyme.

Hydrogen Acceptors used with Dehydrogenase Systems.—Whilst Methylene Blue and other dyestuffs have generally been

used for the study of dehydrogenase under anaerobic conditions, because of the technical advantage of following a colour change, other hydrogen acceptors can also be used. Dinitro-compounds have been employed. Recently, ferricyanide has been used in manometric studies of dehydrogenases under anaerobic conditions (Quastel and Wheatley<sup>62</sup>). Ferricyanide as reduced to ferrocyanide with liberation of acid. The acid reacts with bicarbonate which is added to the system, and the rate of evolution of carbon dioxide is measured manometrically.

Coenzymes of Dehydrogenases.—Harden and Young<sup>24</sup> discovered that the process of glucose fermentation by yeast required the presence of a thermo stable substance which they called cozymase (v. Vol. III, 250c; Vol. V, 15b; Vol. VI, 78c). It is now known that Cozymase is the coenzyme of a number of dehydrogenases, i.e., these enzymes will not accomplish the reduction of hydrogen acceptors such as Methylene Blue or of ferricyanide except in the presence of cozymase.

Warburg and Christian<sup>64</sup> showed that mammalian red blood cells contained an enzyme which catalysed the oxidation of glucose-6-phosphate. The activity of this enzyme was found to depend upon the presence of a coenzyme which was isolated. The substance was found eventually to be composed of nicotinamide, adenine, ribose, and phosphoric acid, thus:

Nicotinamide-d-ribose-(phosphoric acid residue)-d-ribose-adenine.

A little later, Euler, Albers, and Schlenk<sup>15</sup> obtained nicotinamide from cozymase, the structure of which was found to be as follows:

Nicotinamide-d-ribose-(phosphoric acid residue)-d-ribose-adenine.

The work of Warburg and his colleagues<sup>65</sup> made it clear that the co-enzyme of hexose monophosphate oxidation undergoes reduction during the enzyme reaction, the hexose monophosphate becoming oxidised. The reduced form of the coenzyme is not autoxidisable but may be oxidised in a variety of ways. The reversible oxidation and reduction of the coenzyme accounts for its catalytic powers. Spectroscopic evidence made it clear that the nicotinamide part of the molecule is the seat of the oxidoreductive changes. Thus:

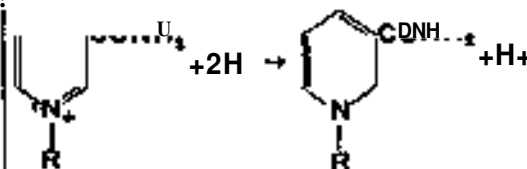

Cozymase, the diphospho-nicotinamide-adenine-dinucleotide is widely distributed and is a coenzyme for a large variety of oxidative enzyme systems. The triphospho-dinucleotide acts as a coenzyme for a smaller number of such systems.

The various specific proteins with each of which cozymase combines reversibly are dehydrogenases capable of activating many substrates and accomplishing their oxidation. Reduced cozymase is equally capable of com-

binning in a reversible manner with dehydrogenases, and activated substrates may oxidise the reduced coenzymes, themselves undergoing reduction. Equilibria are set up in the following ways:

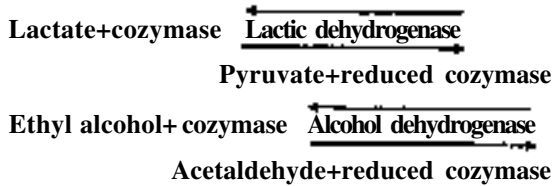

Owing to the fundamental fact that combinations with the coenzyme is not restricted to one dehydrogenase, the coenzyme can act as a link between a variety of oxido-reductive systems. This is shown in the following example:

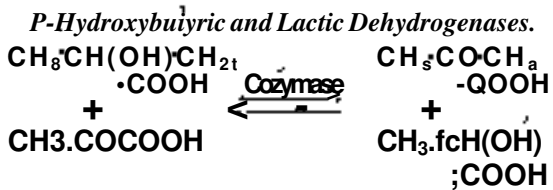

The extent to which these interactions will proceed depends upon the equilibrium constants between coenzyme and the specific dehydrogenases combining, with it and also on whether the action is removed from the equilibrium system by a secondary change.

It is, therefore, possible for cozymase to institute in the cell a whole chain of reactions involving transfer of hydrogen from one molecule to another as long as the appropriate dehydrogenases are present. Its function is that of a middleman capable of receiving hydrogen from various substrates activated by different enzymes and passing it on to other substrates by their enzymes. It regulates the passage of hydrogen in the cell and this way helps to control the rates and courses of the cellular oxidations and reductions of which are shown in Table IV.

TABLE IV.—MOLECULES THE OXIDATIONS AND REDUCTIONS OF WHICH ARE CONTROLLED BY COZYMASE.

Substrate activated as a hydrogen donor by a dehydrogenase.	Substrate activated as a hydrogen acceptor by a dehydrogenase.	Reference.
<ul style="list-style-type: none"> <li>α-Glycerophosphate.</li> <li>Triosephosphate.</li> <li>Lactate.</li> <li>Alcohol.</li> </ul>	<ul style="list-style-type: none"> <li>Triosephosphate.</li> <li>Phosphoglycerate.</li> <li>Pyruvate.</li> <li>Aldehyde</li> </ul>	Euler, Adler and Gttnther. <sup>7</sup> Warburg and Christian. <sup>58</sup> Straub. <sup>58</sup> Negelein and Wulff. <sup>48</sup>
<ul style="list-style-type: none"> <li>Automate.</li> </ul>	<ul style="list-style-type: none"> <li>α-Ketoglutarate + NH<sub>2</sub>.</li> <li>Oxalacetate.</li> <li>Acetoacetate.</li> <li>(?) Gluconate.</li> </ul>	Euler, Adler, Günther and Bis. P. <sup>7</sup> Green. <sup>2</sup> Green, Leloir, and Dewan. <sup>21</sup> Hawthorne and Harrison. <sup>2</sup>

There is no reason to suppose that cozymase and reduced cozymase are any more than substrates for the dehydrogenases. Their affinities for a dehydrogenase are of the same order as those of the more familiar substrates, as in the case of alcohol dehydrogenase and acetaldehyde (Negelein and Wulff<sup>48</sup>). They differ from such substrates, however, in their ability to combine with a large variety of dehydrogenases and are obviously so combined with the enzymes that they do not interfere with the approach of the more familiar substrates. As will be shown later, reduced cozymase must be capable of combination with, and activation by, still another class of enzyme, a flavoprotein. But here it passes its hydrogen to another nucleotide, 'molybdoxazine-adenine-dinucleotide,' which is a constituent of the flavoprotein.

Although neither nicotinic acid or nicotinamide can itself act as a coenzyme in dehydrogenase systems, the latter molecule may indirectly influence the kinetics of isolated oxidising systems. This is due to the fact that cozymase is broken down by a nucleotidase in the tissues and this hydrolytic enzyme has been shown by Mann and Quastel<sup>40</sup> to be inhibited specifically by nicotinamide. Nicotinamide in fact stimulates the respiration of isolated tissue systems because it inhibits the breakdown of cozymase, the integrity of which is necessary for optimal inspiration.

*Riboflavin*

The isolation from yeast by Warburg and Christian,<sup>63, 64</sup> of a conjugated protein which they called a "yellow enzyme" was followed by the isolation from egg white and milk by Kuhn, György, and Wagner-Jauregg<sup>38</sup> and from whey by Ellinger and Koscharra<sup>3</sup> of a lactoflavin which seemed to be identical with the yellow compound associated with the yellow enzyme. György, Kuhn, and Wagner-Jauregg showed that lactoflavin or riboflavin is identical with vitamin-j<sub>2</sub>. The demonstration that this flavin can undergo reductions and oxidations in biological systems served to focus attention on the possible part played by vitamin-j<sub>2</sub> in respiratory systems.

A number of flavoproteins are now known to exist, each having specific catalytic powers in oxidative systems, the coenzyme or prosthetic group associated with the specific protein involved, is usually molybdoxazine-adenine-dinucleotide the structure of which (Kuhn, Reinemund, Kaltschmitt, Strobele, and Trischmann<sup>7</sup>; Karrer, Schöpp, and Benz<sup>88</sup>);

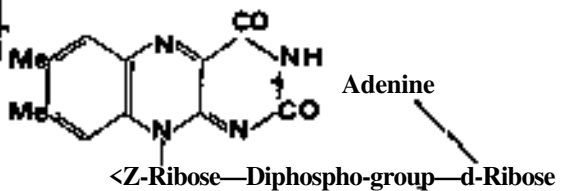

has a remarkable similarity to that of the nicotinamide-adenine-dinucleotide.

The molybdoxazine nucleus, like that of nicotinamide in cozymase, is the seat of oxido-reductive

changes. A list of flavoproteins having specific activating powers is shown in Table IV. These enzymes appear to be responsible for the oxidation of the reduced forms of the diphospho- and triphospho-nicotinamide-adenine - dinucleotides. Such enzymes are known as diaphorases. The long familiar xanthine- and aldehyde-oxidases also are flavoproteins, whilst the oxidation of amino-acids, whether *l*- or *d*-, demands the presence of similar enzymes (*see*, however, Braunstein and Asarkh<sup>6</sup>).

The flavin dinucleotides are for the most part firmly bound to their respective proteins and are not easily dissociated, but *d*-amino-acid oxidase seems to be exceptional in being easily split into its components. At pH 8.5 it dissociates to the extent of 90% and, although it behaves as a dissociated flavoprotein in solution, it precipitates out of solution as a conjugated protein. The reduced form of the oxidase does not appear to dissociate.

The activity of the flavoproteins can be very

high. One molecule of heart-diaphorase flavo protein, for example, will catalyse the oxidation of 8,000 molecules of dihydro-cozymase per minute by an oxidising agent such as Methylene Blue (Straub<sup>67</sup>).

The coenzymes of diaphorase, aldehyde oxidase and *d*-amino-acid oxidase are identical, i.e., flavin-adenine-dinucleotide. Green, Moore, Nocito, and Ratner,<sup>22</sup> however, note that the coenzyme concerned with the flavoprotein responsible for the oxidation of the *Z*-amino acids is not flavin-adenine-dinucleotide.

The flavoproteins may be regarded as a special class of dehydrogenases. They activate their substrates, e.g., reduced nicotinamide-adenine-dinucleotides, amino-acids, aldehydes and purines (*see* Table V), and bring about a transference of hydrogen to the coenzyme of the flavoproteins, i.e., usually flavin-adenine-dinucleotide. They work anaerobically in exactly the same way as the more familiar dehydrogenase?

TABLE V.—FLAVOPROTEINS WITH SPECIFIC ACTIVATING POWERS.

Source of flavoprotein.	Substrates affected.	Enzyme system.	Reference.
Yeast	Reduced cozymase. Reduced triphosphonicotinamide-adenine-dinucleotide. <sup>c</sup>	Diaphorase.	Euler and Hellstrom. <sup>18</sup> Dewar and Green. <sup>11</sup>
Heart	Reduced triphospho-nicotinamide-adenine-dinucleotide.	Diaphorase.	Straub. <sup>57</sup>
Yeast	Triphospho-nicotinamide-adenine-dinucleotide. Cytochrome.	'Cytochrome' reductase.	Haas <i>et al.</i> <sup>TM</sup>
Kidney	<i>d</i> -Amino-acids.	( <i>Z</i> -Amino-acid oxidase.	Wprburg and Christian. <sup>6*</sup>
Milk	Aldehydes. Purines (hypoxanthine). Reduced cozymase.	Aldehyde oxidase. Xanthine oxidase.	Ball. Corran, Green <i>et al.</i> <sup>B</sup>
Kidney	<i>Z</i> -Amino-acids. Reduced cozymase.	<i>Z</i> -Amino-acid oxidase.	Green, Moore, Nocito, and Ratner. <sup>22</sup>
Bacteria	Acetoacetic acid.	Acetoacetic decarboxylase.	Davies. <sup>10</sup>
Bacteria	Pyruvic acid.	Pyruvic oxidation system.	Lipmann.**
Yeast	Fumate acid.	Reductase.	Fischer and Eysenbach. <sup>1</sup>

The reduced flavoprotein is autoxidisable, and its oxidation is not inhibited by cyanide. Thus an oxidation catalysed by flavoprotein need not be sensitive to cyanide. The following is an example of a flavoprotein catalysed oxidation, involving three successive stages:

- (i) Hexose monophosphate + triphospho-nicotinamide - adenine - dinucleotide  
 $\xrightarrow{\text{Dehydrogenase}}$  Phosphohexonic acid + reduced triphosphonicotinamide - adenine-dinucleotide.
- (ii) Reduced triphosphonicotinamide - adenine - dinucleotide + flavoprotein  
 $\xrightarrow{\text{Flavoprotein}}$  Triphosphonicotinamide - adenine - dinucleotide + reduced flavoprotein.
- (iii) Reduced flavoprotein +  $O_2$   
 $\xrightarrow{\text{Flavoprotein}}$  Flavoprotein +  $H_2O$

Theorell,<sup>80</sup> however, pointed out that the rate of oxidation of a flavoprotein at the oxygen tensions obtaining in living tissues is too sluggish to account for normal respiratory rates, and suggested that cytochrome may be involved in the re-oxidation of reduced flavoprotein *in vivo*. This would make a system catalysed by flavoprotein in the living cell sensitive to cyanide. Haas, Horecker, and Hogness<sup>23</sup> have now proved that the flavoprotein concerned with hexose monophosphate oxidation is indeed oxidised by the cytochrome system. Reduced flavoprotein is oxidised also by a dyestuff such as Methylene Blue, or by natural cell pigments such as pyocyanine. The reduction of these substances by dehydrogenase systems is made possible by the flavoproteins present.

With the cyanide-sensitive respiratory systems

in which 'cytochrome is involved, it > seems most likely that flavoproteins play a fundamental part. Indeed, recent work^on the node and site of action of narcotics in respiratory systems suggests that\* the flavoprotein is the most susceptible link in the chain of oxidative events (Michaelis and Quastel^7).

*Amino-acid Oxidases.*

Kisch<sup>8B</sup> found that many amino acids increase the respiration of isolated animal tissues and Bernheim and Bernheim<sup>3</sup> demonstrated the presence of an enzyme in liver suspensions which brought about the oxidation of proline and oxyproline. Krebs<sup>39</sup> showed that different enzymes present in liver and kidney are involved in the oxidative: deamination of Z-amino acids and d-amino acids.> He found that Z-amino acid oxidase is a labile enzyme, inhibited by cyanide and octyl alcohol, whilsM-amino acid oxidase is relatively stable. Warburg and, Christian<sup>66</sup> have found that d-ainino acid oxidase is, a flavoprotein. The products of oxidatibn of the a-aznino acid iij presence of its enzyme consist

of the corresponding aldehyde, ammonia, and hydrogen peroxide.

*Nicotinamide and iao Alloxazine.*

As has been indicated, both these substances form, when combined as adenine-dinucleotides, intracellular carriers in chains of oxido-reduction systems, in the living cell. This appears to be their biological function independently of whether or not they form integral parts of enzyme structures. They allow a great variety of oxidations to take place under anaerobic conditions. These facts fully confirm the conclusion, made for the first time by Quastel and Wooldridge<sup>65</sup> from their work on bacterial growth, that intracellular carriers play an essential part in the metabolism of cells proliferating under anaerobic condition^

*Aneurin.*

Another coenzyme of considerable importance is cocarboxylase, also termed the pyrophosphate ester of thiamine, aneurin or vitamin-2f, Its structure is as follows:

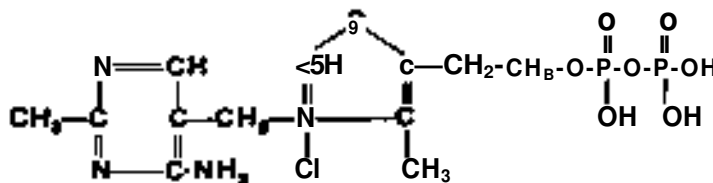

Auhagen<sup>1</sup> discovered that carboxylase, the enzyme which breaks down a-ketóacid into the corresponding aldehydes and carbon dioxide, can be separated into fractions, one consisting of a protein and the other of a thermostable factor termed cocarboxylase. The fractions individually have no catalytic activity; together they have the catalytic activity of the original enzyme, Lohman<sup>2</sup> and Schast<sup>3</sup> showed that cocarboxylase is the pyrophosphoric ester of vitamin B1. This coenzyme is now known, from the work of Peters and his colleagues<sup>74</sup> to be essential for the oxidation of pyruvic acid in animal tissues. It is also known to be essential for the oxidation of acetic acid in certain bacteria (Quastel and Webley<sup>75</sup>). The mechanism of action of this coenzyme is not yet clear.

**AEROBIC OXIDASES,**

The aerobic oxidases as a group appear to require prosthetic groups which usually contain the metals iron or copper.

**IRON-CONTAINING ENZYMES.**

The most important of these enzymes are catalase, peroxidase, and cytochrome oxidase; strictly speaking catalase and peroxidase are not aerobic oxidases as they are not involved in catalyzing oxidations by molecular oxygen. They are, however, intimately involved in oxidation systems.

**Catalase.**—Zeile and Hellström<sup>71</sup> observed that the absorption spectrum of purified pre-

parations of catalase resembles that of iron porphyrin compounds? and that the activity of the enzyme seems to be proportional to the concentration of iron porphyrin in the preparation. The hsematin present was found to be protohsematin. The hsematin could be separated from the protein of the enzyme and when it was coupled with the native globin of horse blood it was found to yield a compound which was identical spectroscopically with horse methsemoglobin. Thus the hsematin of catalase appears to be identical with that of haemoglobin. Catalase has been crystallised (Sumner and Dounce<sup>69</sup>) and its molecular weight estimated to be about 250,000. The number of iron atoms per molecule of catalase is four. Enzymic activity of catalase is directly related to the content of hsematin; the combination of which with hydrogen cyanide, hydrogen sulphide, etc., entirely eliminates enzymic activity. The enzyme combines reversibly with nitric oxide, sodium fluoride, hydrazine, hydroxylamine, ammonia, and sodium azide to give spectroscopically well-defined compounds (Keilin and Hartree<sup>29</sup>; Stern<sup>68</sup>). From the similar behaviour of methsemoglobin with these substances it has been concluded that the iron of catalase exists in the trivalent state. If hydrogen peroxide is added to catalase in the presence of hydroxylamine or sodium azide the three-banded spectrum of catalase becomes two-banded and the compound now combines reversibly with carbon monoxide showing that the iron of the catalase has been reduced to the divalent state. According to Keilin and Hartree<sup>80</sup> the following are the reactions involved



in the decomposition of hydrogen peroxide by catalase.

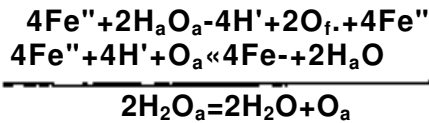

The haematin of catalase when attached to a globin as in methsemoglobin has an activity which is only one millionth that of catalase. Hence the latter contains the specific protein per enzyme the coenzyme or prosthetic group of which is haematin.

**Peroxidase.**—This enzyme, which catalyses oxidations by hydrogen peroxide, is another iron porphyrin complex united with a special protein. It has been shown that in peroxidase the iron always remains in the trivalent state.<sup>31</sup> On addition of hydrogen peroxide, combination with the haematin takes place (1 mol. H<sub>2</sub>O<sub>2</sub> to 1 mol. haematin) just as occurs with methaemoglobin. The complex of hydrogen peroxide and peroxidase is unstable and oxidises molecules such as hydroquinone or pyrogallol, regenerating the peroxidase. Apparently the enzyme may be considered to be a compound of protohaematin with a native globin. The protein differs from that in catalase or methsemoglobin.

**Cytochrome Oxidase.**—This enzyme catalyses the oxidation of the ferrocyanides by molecular oxygen. The system cytochrome oxidase-cytochrome-C7 catalyses the oxidation of cysteine, catechol, adrenaline, and ascorbic acid. It seems also to be responsible for the oxidation of succinate activated by succinic dehydrogenase and of choline by choline dehydrogenase. It also oxidises reduced flavoproteins, and in this way takes part in the main respiratory chain of an aerobic living cell. Cytochrome oxidase is highly sensitive to hydrogen cyanide\*, hydrogen sulphide, and sodium azide at concentrations of 0.001 M. These substances apparently combine with the haematin moiety of the moiety immobilising the iron contained in it. Carbon monoxide inhibits the activity of cytochrome oxidase, the extent of inhibition being determined by the ratio of the pressures of carbon monoxide to oxygen. The affinity of the enzyme to oxygen is five times as great as that for carbon monoxide. The ratio [Fe<sup>++</sup>]/[XCO] (where XCO represents the haematin-carbon monoxide complex) depends on the ratio of partial pressures P<sub>CO</sub>/P<sub>O<sub>2</sub></sub> 5  
s.e., [Fe-]P<sub>CO</sub>/[XCO]P<sub>O<sub>2</sub></sub>

is constant.

The reversal of carbon monoxide inhibition of respiration by light was studied by Warburg, who concluded from the fact that iron carbonyl compounds are dissociated by light and from other relevant data that the "respiratory enzyme" was an iron porphyrin complex. The "respiratory enzyme" of Warburg is identical with cytochrome oxidase.

COPPER-CONTAINING ENZYMES.

Oxidases which contain copper as an essential part of their enzyme systems include polyphenol oxidase (also tyrosinase), laccase, and ascorbic oxidase.

**Polyphenol Oxidase**, also *tyrosinase* (found in plants, moulds, Crustacea, mollusca, insects) brings about the oxidation of adrenaline, tyrosine, phenol, catechol, *m*- and *p*-cresols, pyrogallol, 3:4-dihydroxyphenylalanine. It does not accomplish the oxidation of *o*-cresol, *p*-phenylenediamine, resorcinol, hydroquinone or ascorbic acid. Kubowitz<sup>37</sup> found a preparation of polyphenol oxidase to contain 0.2% copper, which could be removed by adding hydrogen cyanide and dialysing. The inactive enzyme thus prepared was reactivated by addition of copper. Keilin and Mann<sup>82</sup> obtained a preparation containing 0.3% copper, and Dalton and Nelson<sup>9</sup> a preparation containing 0.23% copper. The copper of the enzyme cannot be replaced by iron, cobalt, nickel, manganese, or zinc. Under anaerobic conditions catechol plus catechol oxidase absorbs carbon monoxide thus:

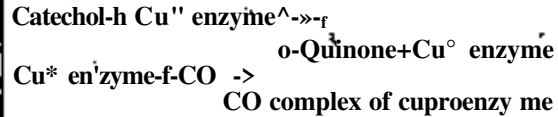

In the absence of catechol the enzyme does not combine with carbon monoxide, indicating that the enzyme when isolated is in the cupric state.

**Laccase**, found in the latex of lac trees, as well as in a variety of plants and fungi, oxidises phenols to *o*- and *p*-quinones. It attacks guaiacol, hydroquinone, pyrogallol, *p*-phenylenediamine, but not tyrosine, resorcinol or *p*-cresol. Keilin and Mann<sup>33, 34</sup> purified laccase from the lac tree and found it to contain 0.24% copper. The preparation is blue in colour. It is inhibited, like other copper-containing enzymes, by sodium azide, hydrogen sulphide, hydrogen cyanide, and sodium dithiocarbamate. Laccase, however, is not inhibited by carbon monoxide (in contrast to polyphenol oxidase).

**Ascorbic Acid Oxidase**, found in many plants, e.g., cucumbers, bananas, lettuce, beans, and spinach, oxidises ascorbic acid to dehydroascorbic acid. It is inhibited by hydrogen cyanide but not by hydrogen sulphide or carbon monoxide. The purified enzyme contains 0.15% copper. It also catalyses oxidation of arboascorbic acid, glucoascorbic acid, and galactoascorbic acid.

The effect of potassium cyanide, hydrogen sulphide, sodium azide, and carbon monoxide on aerobic oxidases is shown in Table VI.

TABLE VI.

Enzyme.	KCN	H <sub>2</sub> S	NaN <sub>3</sub>	CO
Ascorbic acid oxidase	+	-	?	?
Cytochrome oxidase	+	+	+	-
Polyphenol oxidase	+	+	+	+
Laccase	+	+	+	-
Tyrosinase	+	+	+	+
Gatalase	+	+	+	+
Peroxidase	+	+	+	-
[Methemoglobin]	+	+	+	-
[Haemin]	-	-	-	+

+ - Inhibition of enzyme.  
- - no inhibition of enzyme.

*Amine Oxidase.*

This enzyme is identical with aliphatic amine oxidase {Pugh and Quastel<sup>49</sup>}, tyramine oxidase (Hare<sup>25</sup>), adrenaline oxidase (Blaschko, Richter, and Schössmann<sup>4</sup>). It catalyses the oxidation of aliphatic or aromatic amines and amines of the type R-CH<sub>a</sub>-NR', where R'=H or Alkyl. It will not attack amino acids. Its specificity of action is shown in Table VII. Amine oxidase

TABLE VII.

Substrate.	Relative rates of attack by amine oxidase.
Methylamine.	0
Ethylamine.	0
Propylamine.	7
Butylamine.	54
Amphetamine.	19
Heptylamine.	5
isopropylamine.	0
isobutylamine.	9
isopropylamine.	105
Allylamine.	0
Putrescine.	0
Cadaverine.	0
Aniline.	0
Benzylamine.	9
p-Phenylethylamine.	11
o-Phenyl-a-hydroxyethylamine.	46
Tyramine.	100
1:2-Dihydroxyphenylethylamine.	140
β-Indolethylamine.	87

is inhibited by molecules in which a methyl group is attached to the α-carbon atom, such as ephedrine or "benzedrine." The inhibition is reversible and the combination between enzyme and substrate (or inhibitor) follows the mass action law (Mann and Quastel<sup>45</sup>). The enzyme is not inhibited by hydrogen cyanide. It reacts in the following way:

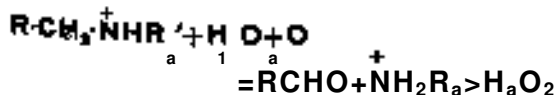

*Diamine Oxidase.*

This enzyme brings about the oxidation of histamine, putrescine, cadaverine, but not ethylenediamine. It does not attack aliphatic or aromatic amines or amino acids. Hydrogen peroxide is the product of oxidation (see Edlbacher and Zeller<sup>72</sup>).

REFERENCES.

1. Uchida, Z. physiol. Chem. 1931, 20, 149; *ibid.* 1932, 20, 20.  
 2. B. J. Biol. Chem. 1939, 128, 51.  
 3. Blaschko, Bernheim, *ibid.* 1032, 96, 325.  
 4. Blaschko, Richter, and Schössmann, Biochem. J. 1931, 25, 216.  
 5. Brooks and Schössmann, J. Biol. Chem. 1931, 92, 535.  
 6. Brauns, J. Biol. Chem. 1945, 157, 42.  
 7. Combs, J. Biol. Chem. 1927, 12, 10.  
 8. Dalziel and Nelson, Straub, *ibid.* 1939, 33, 793.  
 9. Dalziel and Nelson, Amer. Chem. Soc. 1938, 60, 3085.  
 10. Dalziel, Biochem. J. 1943, 37, 230.  
 11. Dalziel, J. Biol. Chem. 1938, 32, 626.  
 12. Edlbacher and Zeller, Helv. chim. Acta, 1937, 20,

» Euler, Adler, and Gunther, Z. physiol. Chem. 1937, 249, 1.  
 13. Euler, Adler, Gunther, and Das, *ibid.* 1938, 254, 83.  
 14. Euler, Albers, and Schlenk, *ibid.* 1935, 237, 1.  
 15. Euler and Helmreich, *ibid.* 1938, 252, 31.  
 16. Fischer and Eysenbacher, Annalen, 1937, 530, 99.  
 17. Green, Biochem. J. 1934, 28, 1550.  
 18. Green, *ibid.* 1936, 30, 2095.  
 19. Green, Dewan, and Leloir, *ibid.* 1937, 31, 934.  
 20. Green, Leloir, and Dewan, *ibid.*  
 21. Green, Moore, Noctlo, and Eatner, J. Biol. Chem. 1944, 156, 383.  
 22. Haas, Horecker, and Hogness, *ibid.* 1940, 136, 747.  
 23. Harden and Young, Proc. Roy. Soc. 1906, B, 125, 171.  
 24. Hare, Biochem. J. 1928, 22, 968.  
 25. Hawthorne and Harrison, *ibid.* 1939, 33, 1573.  
 26. Hopkins, Morgan, and Lutwak-Mann, *ibid.* 1938, 32, 1829.  
 27. Karrer, Schupp, and Benz, Helv. Chim. Acta, 1933, 18, 426.  
 28. Keilin and Hartree, Proc. Roy. Soc. 1936, B, 121, 713.  
 29. Keilin, *ibid.* 1938, 124, 397.  
 30. Keilin and Vtann, *ibid.* 1937, 122, 119.  
 31. Keilin, *ibid.* 1938, 125, 187.  
 32. Idem, Nature, 1939, 143, 23.  
 33. Idem, *ibid.* 1940, 145, 304.  
 34. Kisch, Biochem. Z. 1931, 238, 351; 242, 26, 436.  
 35. Krebs, Biochem. J. 1935, 29, 1620.  
 36. Eubowitz, Biochem. Z. 1937, 292, 221.  
 37. Euhn, György and Wagner-Jauregg, Ber. 1935, 66, 317, 576, 1034.  
 38. Kuhn, Reinemund, Kaltschmitt, Strobele, and Trischmann, Naturwiss. 1935, 23, 260.  
 39. Laki, Z. physiol. Chem. 1937, 249, 63.  
 40. Lehmann, Skand. Arch. Physiol. 1929, 58, 173.  
 41. Idem, Biochem. Z. 1934, 274, 321.  
 42. Lohmann and Schuster, *ibid.* 1937, 294, 188.  
 43. Lippmann, Nature, 1939, 143, 436.  
 44. Mann and Quastel, Biochem. J. 1940, 34, 414.  
 45. Idem, *ibid.* 1941, 35, 502.  
 46. Michaelis and Quastel, *ibid.* 1941, 35, 518.  
 47. Negelein and Wulff, Biochem. Z. 1937, 293, 351.  
 48. Pugh and Quastel, Biochem. J. 1937, 31, 286, 2306.  
 49. Quastel, *ibid.* 1926, 10, 166.  
 50. Quastel and Webley, *ibid.* 1941, 35, 192.  
 51. Quastel and Wheatley, *ibid.* 1938, 32, 936.  
 52. Quastel and Whetham, *ibid.* 1924, 18, 519.  
 53. Quastel and Wooldridge, *ibid.*  
 54. Idem, *ibid.* 1929, 23, 128.  
 55. Stern, J. Gen. Physiol. 1937, 20, 631.  
 56. Straub, Biochem. J. 1939, 33, 787.  
 57. Idem, *ibid.* 1940, 34, 483.  
 58. Sumner and Dounce, J. Biol. Chem. 1937, 121, 417.  
 59. Theorell, Biochem. Z. 1936, 288, 317; Nature, 1936, 138, 687.  
 60. Thunberg, Skand. Arch. Physiol. 1920, 40, 1.  
 61. Idem, *ibid.* 1925, 46, 339.  
 62. Warburg and Christian, Biochem. Z. 1932, 254, 438.  
 63. Idem, *ibid.* 1933, 266, 377.  
 64. Idem, *ibid.* 1936, 287, 20.  
 65. Idem, *ibid.* 1938, 295, 261; 296, 294; 297, 417; 298, 150.  
 66. Idem, *ibid.* 1939, 303, 40.  
 67. Weil-Malherbe, Biochem. J. 1937, 31, 2080.  
 68. Wurmser and Mayer-Reich, J. Chim. phys. 1933, 30, 249.  
 69. Wurmser and Wurmser, *ibid.* 1936, 33, 577.  
 70. Zeile and Hellström, Z. physiol. Chem. 1930, 192, 171.  
 71. Zeller, Helv. Chim. Acta, 1937, 21, 880.  
 72. EUinger and Koxhara, Ber. 1933, 66 [B], 315, 808.  
 73. Gavrillescu, Meiklejohn, Passmore, and Peters, Proc. Roy. Soc. 1032, B, 110, 431.

J. H. Vj.

OXYACANTHINE occurs in the bark of *Berberis vulgaris* (Fam. Berberidaceae) or Barbary Bark, together with berbamine and berberine (Vol. I, 682d, 683c). It is a colourless crystalline alkaloid of the biscoclaurine group (Vol. III, 230c; VI, 496d). Authorities differ as to the empirical formula, C<sub>8</sub>H<sub>38</sub>O<sub>6</sub>N<sub>2</sub> (Vol. VI, 683c) or C<sub>37</sub>H<sub>40</sub>O<sub>6</sub>N<sub>4</sub> (T. A. Henry, "Plant Alkaloids," 3rd ed. 1939, p. 351).

J. N. G.



the atmosphere could be detected during a careful investigation (Carpenter, J. Amer. Chem. Soc. 1937, 59, 358), in which samples were taken from widely differing areas of the United States of America.

Oxygen is an essential constituent of animal and vegetable tissues and fluids. It is absorbed from the atmosphere by animals and plants during respiration, and given off by plants when they assimilate carbon dioxide from the air in sunlight, a fact established by Priestley in 1776. The abstraction of oxygen from the air by plants and animals is counterbalanced by the oxygen evolved by green foliage.

By use of a spectroscopic method oxygen has been shown to be present in the sun. It is also found in meteorites.

PREPARATION.

There are a great many methods available for the preparation of oxygen, the particular process employed depending on the availability of materials and apparatus and the purity and cost of the required oxygen. The available methods may be conveniently classed as follows:

1. *Decomposition of Oxides by Heat.*—The Oxides of the precious metals decompose on heating to give oxygen and the metal. Aurora and auric oxides decompose at about 205°C, silver oxide at 250°C, and the oxides of palladium, indium, mercury, and platinum at higher temperatures. The most familiar reaction of this class is the decomposition of mercuric oxide,  $2\text{HgO} = 2\text{Hg} + \text{O}_2$ , around which so much of the history of oxygen has centred.

A large number of peroxides and higher oxides are converted on heating to lower oxides, with evolution of oxygen; e.g., manganese dioxide, when heated to moderate redness, evolves oxygen ( $4\text{MnO}_2 = 2\text{Mn}_2\text{O}_3 + \text{O}_2$ ). The reaction is reversible, but if the temperature is raised to 400°C a further quantity of oxygen is evolved according to the equation



Lead dioxide heated above 310°C decomposes into lead oxide and oxygen, and red lead,  $\text{Pb}_3\text{O}_4$ , when strongly heated, yields oxygen and a residue of lead oxide by a reversible reaction. The peroxide is readily decomposed by heat, the reaction being reversible, and forming the basis of Brin's process,  $2\text{BaO}_2 = 2\text{BaO} + \text{O}_2$ .

2. *Decomposition of Oxy-compounds by Heat.*—Compounds rich in oxygen such as chlorates, perchlorates, permanganates, bichromates, and persulphates decompose on heating, evolving high purity of the oxygen evolved is the oxygen, the impurities depending on the nature of the compound.

Potassium chlorate, which is the most widely used, decomposes at 370°C and at 500°C according to the equation



As the reaction proceeds the mass becomes porous owing to the formation of Potassium perchlorate (p. 610c.), and the evolution of gas ceases,

$4\text{KClO}_3 = 3\text{KClO}_4 + \text{KCl}$ . On raising the temperature the perchlorate melts and oxygen of high purity is evolved. The decomposition may be catalysed by the addition of certain oxides, e.g.,  $\text{MnO}_2$ ,  $\text{Cr}_2\text{O}_3$ ,  $\text{Fe}_2\text{O}_3$ ,  $\text{Co}_2\text{O}_3$ ,  $\text{NiO}$ ,  $\text{V}_2\text{O}_5$ ,  $\text{WO}_3$ , and  $\text{CuO}$ . These catalysts are presumed to take part in a series of chemical reactions in which the metal of the catalyst assumes a higher valency-state.

The potassium chlorate decomposition involving manganese dioxide as a catalyst takes place steadily at 240°C and has been studied in detail. Traces of potassium permanganate and chlorine have been detected in the products, and the manganese dioxide undergoes a change of physical state during the reaction. It is supposed, therefore, that the following consecutive reactions occur:

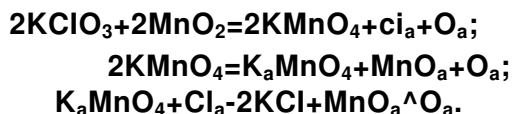

Oxides of zinc and magnesium, which do not form higher oxides, have only slight catalytic action. Spongy platinum is an active catalyst for the reaction, an effect which is attributed to the surface activity of platinum with respect to oxygen.

Fatal accidents have occurred during the preparation of oxygen from manganese dioxide and potassium chlorate, due to coal dust present as an impurity in the manganese dioxide, and care should therefore be taken to ensure that such impurities are absent.

The vapour of sulphuric acid passed through bricks at bright red heat is decomposed into sulphur dioxide, water, and oxygen, and the product after scrubbing the gases is substantially pure oxygen.

Potassium and sodium nitrates decompose at high temperatures to give the metal nitrite and oxygen, which, however, contains nitrogen and oxides of nitrogen as impurities.

3. *Decomposition, other than Thermal, of Oxides and Oxy-compounds.* (Chemical Reactions resulting in the Formation of Oxygen.)—Many peroxides yield oxygen when treated with water, e.g.,  $2\text{Na}_2\text{O}_2 + 2\text{H}_2\text{O} = 4\text{NaOH} + \text{O}_2$ . This reaction can be conveniently adapted for use in a Kipp's apparatus. Several commercial products are described, all of which include sodium peroxide, a catalyst to control the reaction, and a substance to act as binder. Hydrogen peroxide itself is decomposed by heat or by means of a catalyst giving oxygen of a high degree of purity, although the cost is high. 10% hydrogen peroxide can be readily decomposed by  $\text{MnO}_2$ ,  $\text{Pb}_3\text{O}_4$ ,  $\text{PbO}_2$ ,  $\text{K}_2\text{Cr}_2\text{O}_7$ ,  $\text{KMnO}_4$ , or by  $\text{K}_3\text{Fe}(\text{CN})_6$  in alkaline solution.

Chromic acid, manganese dioxide, and potassium dichromate evolve oxygen when heated with concentrated sulphuric acid:

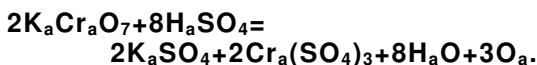

By heating a mixture of calcium sulphate and silica, sulphur dioxide, oxygen, and a residue of calcium silicate are obtained.

A mixture of sodium nitrate and zinc oxide gives a mixture of nitrogen and oxygen on heating, according to the following equation:



Aqueous solutions of alkali hypochlorites readily yield oxygen at the boiling-point in the presence of a catalyst. The required conditions are easily secured by passing a current of chlorine through a boiling concentrated solution of sodium hydroxide to which a small quantity of a cobalt salt has been added. The reaction cycle may be represented by the following equations:

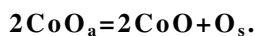
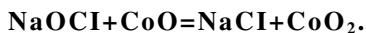

By the action of chlorine on certain oxides at high temperatures, oxygen is evolved, e.g.,  $2\text{ZnO} + 2\text{Cl}_2 = 2\text{ZnCl}_2 + \text{O}_2$ . Oxides of the alkaline earth metals, namely calcium, strontium, and barium oxides, and also lead and cadmium oxides, have been used in this reaction.

Certain organic compounds which take up oxygen readily to form loosely bound molecules, can be decomposed on heating to give oxygen; e.g., rubene,

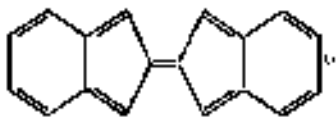

and its derivatives absorb oxygen in solution at room temperature and evolve it again when the solution is heated (Dufraisse, Bull. Soc. chim. 1933, [iv], 53, 789).

Oxygen of very high purity has been obtained by the electrolysis of barium hydroxide solution using platinum electrodes, and also by the thermal decomposition of pure potassium permanganate.

Fluorine is the only element which is sufficiently electronegative to bring about the instantaneous discharge of oxygen ions. The action of fluorine on water is expressed by the equation:  $\text{F}_2 + \text{H}_2\text{O} = 2\text{HF} + \text{O}$  (oxygenated oxygen).

#### PHYSICAL PROPERTIES.

The electronic structure of the oxygen molecule,  $\text{O}_2$ , has been studied by the method of molecular orbitals, by Mulliken (Rev. Mod. Physics. 1932, 4, 1). The molecule is assigned to the  $^3\Sigma_g^-$  ground state, the paramagnetism of the molecule thus being accounted for, since this state has a resultant spin momentum. On the older electron-pair theory of valency the oxygen molecule is considered as having two common  $2p$  orbitals. The O—O distance in the molecule in the ground state is 1.207 Å. The interatomic distances in the various electronic and vibrational states of the molecule have been found by Babcock (Proc. Nat. Acad. Sci. 1937, 23, 301) to vary between 1.2046 and 1.2528 Å.

The Gaseous State.—Oxygen is a colourless diatomic gas, which is commonly regarded as tasteless and odourless. J. B. S. Haldane states, however, that at 6 atm. pressure it possesses a definite taste. When examined through very

thick or highly compressed layers oxygen possesses a faint blue colour.

A litre of oxygen at N.T.P. weighs 1.42901 g.; the molecular volume at N.T.P. is 22.4137 ± 0.0001, a value which has been used as a basis for atomic-weight determinations (Moles, Compt. rend. 1942, 214, 424). The specific gravity (air=1) is 1.10527, a cubic foot of oxygen weighing 0.08921 lb.

The viscosity,  $\eta$ , according to Johnston and McGloskey (J. Physical Chem. 1940, 44, 1038) is  $1.502 \cdot 3 \times 10^{-7}$  C.G.S. units at 270°K.,  $1.958 \cdot 3 \times 10^{-7}$  at 280°K., and  $2.015 \cdot 3 \times 10^{-7}$  at 290°K.

The thermal conductivity,  $k_t$ , is  $5.83 \times 10^{-5}$  cal. sec<sup>-1</sup>, deg<sup>-1</sup>. cm<sup>-1</sup>. (Kannulnick and Martin, Proc. Roy. Soc. 1934, A, 144, 496). The ratio of the specific heats,  $\gamma$ , is 1.396, a value which is characteristic of a diatomic gas; the molecular heats in g.-cal. per g.-mol. have been determined; at constant pressure,  $C_p = 6.950 + 0.000188T + 0.60000(K)672^2$ , and at constant volume,  $C_v = 4.982 + 0.000212T + 0.00000055T^2$ . The temperature dependence of the specific heat at constant pressure in terms of absolute degrees Fahrenheit and British Thermal Units is given by the following equation:

$$C_p = 11.515 - (172/v^3) + (1.53 \times 10^{-4}/T) \text{ B.Th.U. per lb.-mol.}$$

The entropies and specific heats of gaseous oxygen from 400° to 5,400° F. abs. have been tabulated by Geyer (Engineering, 1945, 159, 381, 423).

The refractive index measured for the sodium D line is 1.000310 (Stoll, Ann. Physik, 1922, [iv], 4, 69), oxygen being the least refractive of all gases. A characteristic, though not very strong, absorption spectrum is obtained by viewing the light source through a considerable thickness of the gas. The spectrum first appears in the form of a number of fine lines, but as the pressure is increased it shows a number of broader shaded bands, together with almost complete absorption in the visible and ultra-violet. Six absorption bands have been observed, including two strong bands in the red corresponding with the A and B Fraunhofer lines, with wavelengths from 6,340 Å. to 6,225 Å., a strong band in the yellow from 5,820 Å. to 5,730 Å., and feebler bands in the green at 5,350 Å. and the blue at 4,810 Å. Liquid and gaseous oxygen have practically identical absorption spectra, and in consequence the liquid has been studied in preference to the compressed gas. Very highly compressed oxygen is reported by Finkelburg and Steiner (Z. Physik. 1932, 73, 66), to possess continuous bands in the region 2,300-2,900 Å., not observed at ordinary pressures, and it is suggested that this is due to  $\text{O}_4$  molecules.

The emission spectrum obtained in the discharge tube consists of the following main lines: red, A 6,158-2 Å., green A 5,436-8,6,330-7 Å., violet A 4,368-3 Å.

The dielectric constant is 1.00050 at 293°x. and 760 mm. pressure (Van Itterbeck and Spaepen, Physica, 1943, 10, 173). Oxygen is paramagnetic. Hector (Physical Rev. 1924, [v], 23, 209), gives a value of  $\chi = 108 \cdot 2 \times 10^{-6}$  for the magnetic susceptibility at 0° o.f. whilst Burns

and Hause (J. Chem. Physics, 1943, 11, 442) obtain the value  $x=(106.3 \pm 0.2) \times 10^{-6}$ .

The solubility of oxygen in water follows Henry's Law fairly closely. The table below gives values of the coefficient of solubility (i.e., the volume of oxygen absorbed by one volume of water when brought to equilibrium with pure oxygen under 760 mm. pressure) at different temperatures as determined by various observers.

Temp. °C.	Bun- sen, 1855.	Winkler, 1891.	Bohr and Bock, 1891.	Fox, 1905.	Aderay and Becker, 1919.
0	00411	004890	004961	004924	0-046W
10	00325	003802	003903	003837	0-03620
20	00284	003102	003171	003144	002965
30	—	002608	002676	002665	002479
40	—	002306	002326	002330	—
50	—	0*02090	00?070	0-02095	—

\*Winkler gives the following formula for calculating the coefficient of solubility ( $S$ ) for oxygen in water at any temperature,  $t$ , from 0° to 30°o.:

$$0.0-0.04890-0.0013413M-0.0000283t^2-0.0000002953t^3.$$

Fox gives an analogous expression for the temperature interval 0-50°o.:

$$0=0049239-000134401+0000028752t^2-00000003024t^3.$$

A graphical representation of the solubility of oxygen in water from 32° to 212°F., and at pressures from 0-30 in. of mercury, is given by West (J. Ind. Eng. Chem. 1922,14, 603).

Rain-water is very nearly saturated with oxygen when its temperature as collected is below 15°o. During the summer months the dissolved oxygen is always less than the saturation quantity, sometimes by as much as 25%. Nearly all natural waters contain oxygen in solution and can only be freed therefrom by prolonged boiling in vacuum. The dissolved oxygen, though small in amount, is the source of life for many aquatic organisms. It is necessary to

The solubility of oxygen in sea water at 16°o. is about 78% of its solubility in pure water. All will dissolve less oxygen than pure water. For example, only very sparingly in saturated solutions of very soluble salts, such as ammonium chloride, oxygen is much more soluble in alcohol than in water, the coefficient of solubility being 0.2337 at 20°o. The coefficient of solubility of oxygen in organic solvents is generally greater than in water; e.g., at 20°o. in chloroform,  $S=0.205$ ; acetone,  $S=0.207$ ; ether,  $S=0.163$ .

Oxygen is appreciably soluble in molten metals and to a lesser extent in solid metals. The solution appears to be one of interstitial solution rather than pure solution.

Th. Br. Tu. r. Z. Elektrochem. 1936, 42, 841).

The solubility of oxygen in molten silver is very great—one volume of the metal dissolving about seven volumes of oxygen, most of which is evolved on cooling. The solubility curve for

oxygen in silver has been calculated by Simons (J. Physical Chem. 1932, 36, 652), and determined experimentally over a wide range of temperature and pressure by Steacie and Johnson (Proc. Roy. Soc. 1926, A, 112, 542). The solubility is proportional to the square root of the pressure. The solubility-temperature curve has a minimum at 400°o. The following values were obtained:

$t^{\circ}O.$	200	300	400	500
(Vol. of O <sub>2</sub> )/(Vol. of Ag) at 760mm.	0.138	0.095	0.085	0.093
«0.	600	700	800	
(Vol. of O <sub>2</sub> )/(Vol. of Ag) at 760 mm.	0.129	0.188	0.346	

Gold, platinum, and palladium in the solid state absorb oxygen at elevated temperatures: Iron at room temperature contains 0.006-0.003% of dissolved oxygen; copper of high purity has been shown to contain 0.0018% of oxygen at 550°o. and 0.0070% at 1,040°o.

Wood charcoal can absorb oxygen at room temperature; 1 g. absorbs 8.2 c.c. under normal pressure, according to McBain, whilst at lower temperatures the volume of gas absorbed increases rapidly, a fact which is made use of in removing traces of air from evacuated vessels. On heating, all the oxygen is removed.

Liquid State.—Faraday, in his classical investigations on the liquefaction of gases, did not obtain liquid oxygen, since the refrigerating agents which he used did not permit of the attainment of the critical temperature of the gas. Oxygen was first liquefied by Cailletet in 1877 and also almost simultaneously by Pictet. The former investigator effected the cooling merely by sudden expansion of the gas from a pressure of 300 atm., and obtained only a mist of small globules of liquid oxygen. Pictet, however, cooled the gas, already compressed to 320 atm., to -140°c, a temperature which was obtained by the rapid evaporation of carbon dioxide. Liquid oxygen was first produced in sufficient bulk for a satisfactory examination of its properties by Wroblewski and Olszewski, who made use of liquid ethylene boiling under reduced pressure for the initial cooling of the gas. These workers determined the following critical constants (1885):  $J_{PO}=-118^{\circ}o.$ ,  $P_c=50$  atm., and  $T_c=0.00426$ .

The critical pressure of oxygen is now accepted as 49.7 atm.; the corresponding critical temperature is -118.8°o., and the critical density 0.430 g. per c.c. (Pickering, J. Physical Chem. 1924, 28, 97).

Liquid oxygen is a pale steel-blue, transparent, and very mobile liquid. The boiling-point has been variously determined, the most probable value being -182.02 at 0.03°o. at 760 mm. (Aoyama and Kanda, Bull. Chem. Soc. Japan, 1935, 10, 472). Between 0.05 and 49.7 atm. the vapour pressure is represented by the following equation (Dodge and Davis, J. Amer. Chem. Soc. 1927, 49, 610):

$$\log_{10} p/\text{atm.} = 372.808/T + 4.18939 - 0.0006195Z^1$$

or by a simpler form:

$$\log_{10} P/\text{atm.} = 366523/T + 406205.$$

The liquid density has been determined by many observers, the results showing considerable divergence. The variation of density with temperature was determined by Inglis and Coates (J.C.S. 1906, 89, 886);  $D = 1.5154 - 0.00442T$  (where  $T$  is the absolute temperature). The density at the boiling-point as determined by Onnes and Perrier (1910) is 1.14.

Grunmach (Ann. Physik, 1907, [iv], 22, 107) obtains a value of 13074 dynes per cm. for the surface tension at the boiling-point. The viscosity,  $\eta$ , of liquid oxygen, according to Rudenko (J. Exp. Theor. Physics (U.S.S.R.), 1939, 9, 1078), is  $19 \times 10^{-4}$  C.G.S. units at  $90.1^\circ\text{K}$ .

The refractive index at the boiling-point for  $\lambda = 5461 \text{ \AA}$ . is 1.2242.

The coefficient of expansion with rise of temperature at  $-250^\circ\text{C}$ . has been determined by Onnes as  $0.00157$ . The specific heat of liquid oxygen is 0.400 g.-cal. per g. at  $-215.7^\circ\text{C}$ ., and 0.394 g.-cal. per g. at  $-200.1^\circ\text{C}$ .. The heat of vaporisation at the boiling-point under 760 mm. pressure is 50.92 g.-cal. per g. (Alt, Ann. Physik, 1906, [iv], 19, 739).

Liquid oxygen is a non-conductor of electricity, but it is strongly magnetic, its magnetic moment being equal to 1 when iron is considered as 1,000. The magnetic susceptibility in mass units is  $241 \times 10^{-6}$  at  $-183^\circ\text{C}$ .. The dielectric constant at the boiling-point is 1.463.

Nitrogen from the air is absorbed readily by liquid oxygen, a fact which probably accounts for the discrepancies in the values of some of the physical constants.

Solid State.—Solid oxygen, obtained by the rapid evaporation of liquid oxygen or by use of liquid hydrogen, is a hard, pale-blue doubly refracting, crystalline mass, melting at  $-218.81 \pm 0.05^\circ\text{C}$ .. (Giauque and Johnston, J. Amer. Chem. Soc. 1929, 51, 2,300).

The density at  $-252.5^\circ\text{C}$ .. is 1.4256, and the variation with temperature ( $t^\circ\text{C}$ .) is represented by the equation:

$$D = 1.5154 - 0.004420(t + 273).$$

The effect of pressure on the melting-point has been shown to be represented by the equation:

$$t_{\text{m}}(p) = 0.81 - 8p = 4 - 1381 \log_{10} T - 4.145465.$$

The triple point, by extrapolation, lies at  $54.32^\circ\text{X}^\circ$  (Lisman and Keesom, Physica, 1935, 2, 901).

The heat of fusion is 3.3 g.-cal. per g., at  $-219^\circ\text{C}$ ..

The magnetic susceptibility has the following values:  $\chi = 375 \times 10^{-6}$  at  $-253^\circ\text{C}$ .,  $436 \times 10^{-6}$  at  $-259^\circ\text{C}$ ., and  $500 \times 10^{-6}$  at  $-260^\circ\text{C}$ ..

Solid oxygen occurs in three modifications,  $\alpha$ ,  $\beta$  and  $\gamma$ , from  $23.5^\circ\text{K}$ . to  $43.5^\circ\text{K}$ ., and  $\gamma$  from  $43.5^\circ\text{K}$ . to the melting-point. The crystal structures of the  $\alpha$ - and  $\beta$ -forms are still in some doubt, although it has been suggested that the  $\alpha$ -structure possesses a trigonal (rhombohedral) cell containing six molecules ( $a = 6.19 \text{ \AA}$ .,  $\beta = 99.1^\circ$ ), corresponding to a density of 1.395. However the  $\gamma$ -form gives X-ray powder diagrams which correspond with a cubic cell ( $a = 6.83 \text{ \AA}$ .), containing eight molecules, corresponding to a density of 1.30. The lattice of the  $\gamma$ -form belongs to the space-group  $T^h$ .

Colloidal State.—Oxygen has been obtained in the colloidal form by Krause and Kapitancyk (KoUoid-Z. 1935, -VI, 55). The method employed was to dilute distilled water saturated with oxygen by means of a large volume of 18.55-19.60N. sodium hydroxide solution. The colloidal particles produced were 5 m $\mu$ . to 3 m $\mu$ . in diameter.

#### OXYGEN AS A BASIS FOR ATOMIC WEIGHTS.

Dalton (1803) originally selected hydrogen, having the lowest atomic weight, as an arbitrary standard for atomic weights, but the inconvenience of this choice was soon recognised, since few stable hydrides existed and hence indirect comparisons were necessary. Berzelius (1830) employed the standard  $O = 100$ . Dumas, using the hydrogen scale, found  $O = 16.06$ , and regarded the value 16 as probably correct. Stas (1860) suggested that the standard be taken as  $O = 16$ , but this met with little support at that time since it would have involved very little change in the accepted values of the atomic weights. However, during the period 1888-95 the use of  $O = 16$  as a basis for atomic weights became accepted and is now adopted by international agreement.

The announcement of the discovery of an isotope of oxygen of mass 18 in 1929 by Giauque and Johnston (Nature, 1929/123, 318), necessitated a reconsideration of oxygen as an atomic weight standard.  $^{16}\text{O} = 16.00000$  was chosen as the basis of the "physical atomic weights," determined by means of the mass spectrometer. A knowledge of the relative abundance of the oxygen isotopes is necessary to determine the conversion factor of "physical" to "chemical" atomic weights. Several values have been quoted, the most recent and probably the most reliable being  $^{16}\text{O}/^{18}\text{O} = 500 \pm 16$ ,  $^{16}\text{O}/^{17}\text{O} = 4.9 \text{ dbO-2}$ ; thus the physical-to-chemical mass-scale conversion factor is  $1.000275 \pm 0.000009$  (Murphy Physical Rev. 1041, [ii], 59, 320).

An examination of the constancy of the abundance of oxygen isotopes,  $^{17}\text{O}$  and  $^{18}\text{O}$ , has revealed a variation occurring in samples of water taken from the sea, inland waters, the atmosphere, and snow (Bleakney and Hippie *ibid.* 1935, [ii], 47, 800). This variation is assumed to be due to natural exchange reactions leading to the enrichment of one isotope. Dole (J. Chem. Physics, 1936, 4, 268) found a difference of 0.00011 units of atomic weight between oxygen from Lake Michigan (U.S.A.) water (taken exactly as 16.00000) and the oxygen of air (16.000108). If the atomic weight of oxygen in the water from Nevada Hot Springs is taken as 16.000000, the atomic weight of the oxygen in Lake Michigan water is 16.000034 and that of atmospheric oxygen is 16.000142. The variation in the atomic weight of oxygen does not apparently affect the experimentally determined values of the chemical atomic weights, but for refined atomic-weight determinations a simultaneous isotopic analysis of the oxygen may be necessary.

#### ISOTOPES OF OXYGEN.

The evidence for the  $^{18}\text{O}$  isotope announced by Giauque and Johnston in 1929 (Nature, 1929,



128, 318) was presented later in the same year (J. Amer. Chem. Soc. 1929, 51, 1436). It consisted of an examination of the atmospheric spectrum from data already obtained by Dieke and Bahcock (Proc. Nat. Acad. Sci. 1927, 13, 670), in which the lines of a very faint A' band, appearing as duplicates of the lines of normal oxygen A band, agreed very closely with the calculated absorption for an oxygen molecule containing  $^{18}\text{O}$ . Further examination revealed the presence of  $^{17}\text{O}$  present in smaller quantities (J. Amer. Chem. Soc. 1929, 57, 3528).

Many attempts have been made by different workers to concentrate  $^{18}\text{O}$ . Urey, Urey, and Bocker (Naturwissenschaften, 1943, 31, 210) have obtained 99.0% pure  $^{18}\text{O}_2$ , the impurity consisting of  $^{17}\text{O}^{18}\text{O}$ . The method used was that of the differential diffusion, six units of total length 82 m., with a heating wire of a platinum alloy and water cooling, were used, the total power being 7 kw. A total of 50 c.c. of  $^{18}\text{O}_2$  was prepared in the course of 1 1/2 years; as an intermediary 90%  $^{18}\text{O}_2$  was isolated. The platinum wire is stated to establish the equilibrium  $2^{16}\text{O}^{18}\text{O} \rightleftharpoons ^{16}\text{O}_2 + ^{18}\text{O}_2$ .

The fractional diffusion method of Kertész (Z. Physik, 1934, 91, 810) and Barwich (ibid. 1936, 100, 167) gives a sufficiently increased concentration for experimental work, but the quantity obtained is small.

The vapour pressure of  $\text{H}_2^{18}\text{O}$  differs only slightly from that of  $\text{H}_2^{16}\text{O}$ . Wahl and Urey (J. Chem. Physics, 1935, 3, 411), found that the ratio of the vapour pressures of  $\text{H}_2^{18}\text{O}$  and  $\text{H}_2^{16}\text{O}$  is 1.012 at 11-25°C. and 1.0077 at 46-35°C.; by extrapolation the figure at 0°C. is 1.003. Many attempts have been made to utilise these data in distillation processes to obtain water enriched with  $^{18}\text{O}$ . The most recent attempt was that of Thode, Smith, and Walkling (Canad. J. Res. 1944, 22B, 127), who by use of three 25-ft. columns packed with "Hydrite" aggregate operated in cascade for 120 days, obtained 50 ml. of water enriched 6.5-fold in  $^{18}\text{O}$  and 6.7-fold in  $^{17}\text{O}$ . Several experimenters previously used copper fractionating columns, e.g. Brodskii and Skarre (Acta Physicochim. USSR, 1939, 10, 729) and Huffman and Urey (Ind. Eng. Chem., 1937, 29, 531). The latter workers used a fractionating column built in 5 y-sections; each section was 5 ft. long and 1/2 in. in diameter and was fitted with 87 stationary and rotating cones which served to provide a large exchange surface. A few hundred c.c. of 0.85%  $\text{H}_2^{18}\text{O}$  were obtained in this way.

The possibility of the electrolytic separation of oxygen isotopes has been examined, and the separation factor shown to be 1008 (Hall and Johnston, J. Amer. Chem. Soc. 1935, 57, 1515).

A somewhat higher value of the separation factor was obtained by Thomson and Urey (Trans. Faraday Soc. 1938, 34, 766), and it thus appears possible that the value of the separation factor depends on the nature of the electrode material or the conditions of the electrolysis. By using the figure 1008 for the separation factor it has been estimated that the relative concentration of an entire ocean would be less than 100 times the concentration of the heavy isotopes

of oxygen (Johnston, J. Amer. Chem. Soc. 1935, 57, 484).

Separation of the heavier isotope has been achieved using exchange reactions. Below are listed three typical reactions with the equilibrium constants measured at 298°K.:

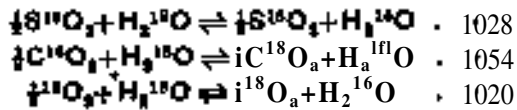

The relative proportions of heavy to light oxygen in air and water depends on the equilibrium shown in the last equation being set up.

Normally a relatively high temperature and a catalyst are required for the equilibrium to be established, but it is possible that in nature it may be attained relatively rapidly in the stratosphere under the influence of ultra-violet radiation from the sun (Dole, J. Chem. Physics, 1936, 4, 272). The second reaction may also be involved, whereby carbon dioxide rich in  $^{18}\text{O}$  is produced and absorbed by plants with subsequent liberation of  $^{18}\text{O}_2$ .

The determination of the proportion of heavy oxygen in water may be made by density measurement. An accuracy of the order of one part per million may be obtained after careful purification of the water, including a "normalising" process, such as exchange with ammonium chloride, to remove enriched deuterium.  $^{18}\text{O}$  in organic compounds is determined by combustion with excess hydrogen, using a cracking surface of granulated quartz coated with platinum followed by a nickel catalyst containing 2% of thorium Russell and Fulton, Ind. Eng. Chem. [Anal.], 1933, 5, 384).

Cohn and Urey (J. Amer. Chem. Soc. 1938, 60, 679), described a method using the mass spectrometer. A known weight of water to be analysed is shaken at room temperature with a known volume of carbon dioxide until equilibrium is reached (2-3 hours). The proportion of  $^{18}\text{O}$  in the carbon dioxide is then readily determined by using the mass spectrometer.

The refractive index of water containing heavy oxygen can be calculated from the expression obtained by Lewis and Luton (J. Amer. Chem. Soc. 1933, 55, 5061),  $\frac{y}{x} = \frac{100008y}{A \cdot f}$ , where  $A$  is the difference in  $n_x$  at 25°C. over ordinary water and  $y$  is the increase in mol. fraction of heavy water. The refractive index can thus be used to follow heavy oxygen enrichment in water.

The masses of  $^{16}\text{O}$  and  $^{18}\text{O}$  on the physical scale have been computed from optical data as 170026 and 180065 (Birge, Physical Rev. 1921, [ii], 37, 841). Stetter (Z. Physik, 1936, 100, 652), from consideration of the radioactive excitation reaction  $^{17}\text{O} + ^4\text{He} \rightarrow ^{21}\text{F} + ^1\text{H}$ , derives the value of the mass of  $^{17}\text{O}$  as 170046.

$^{18}\text{O}$  interchange has been used to study a variety of reactions. Most notable is the investigation of oxygen interchange between oxy-anions and solvent water. Winter, Carlton, and Briscoe showed that no exchange occurs between  $\text{H}_2^{18}\text{O}$  and sulphates at 100°C. in acid, neutral, or alkaline solution (J.C.S. 1940, 131). However, according to Hall and Alexander (J. Amer. Chem. Soc. 1940, 62, 3455), the change is catalysed by hydrochloric acid. The exchange

has been shown to occur slowly in the case of  $\text{SiO}_2$ ,  $\text{BO}_3$ ,  $\text{BO}_2$ ,  $\text{B}_2\text{O}_3$ ,  $\text{Cr}_2\text{O}_7$ ,  $\text{CrO}_4$ ,  $\text{MoO}_4$ ,  $\text{WO}_4$ ,  $\text{CO}_2$ ,  $\text{MnO}_4$ ,  $\text{IO}_3$ ,  $\text{SeO}_3$ ,  $\text{SO}_2$ ,  $\text{S}_2\text{O}_3$ ,  $\text{AsO}_4$ ,  $\text{AsO}_3$  but not with  $\text{NO}_2$ ,  $\text{ClO}_2$ ,  $\text{ClO}$ , and  $\text{SeO}_4$ . The chief mechanisms proposed to account for these exchange reactions are summarised below:

(i) Dehydration, followed by hydration. This appears to be the mechanism whereby silicates, borates, and possibly chromates, exchange.

(ii) Hydration, followed by dehydration. This probably plays a part in the case also of borates and in the case of carbon dioxide.

(iii) Temporary covalency increase.

Difficulty has been experienced, however, since not all of the interchange reactions can be explained in terms of these three comparatively simple mechanisms.

Monita (full. Chem. Soc. Japan, 1940, 15, 47, 226, 298), has examined the isotope exchange between gaseous oxygen and water vapour on catalytic oxide surfaces. The rate of exchange on aluminium oxide surfaces was found to be almost independent of the composition of the gas mixture, indicating that the determining factor is the activated absorption of water on the oxide surface.

Using  $\text{H}_2^{18}\text{O}$  the Beckmann rearrangement has been shown to proceed by means of an intermediate dehydration. Acylation of  $\text{Et}^{\text{OH}}$  with acetic anhydride showed that the resulting ester contains one oxygen atom from the alcohol and one from the anhydride, whilst the alkaline fusion of sulphonates using  $\text{Na}^{18}\text{OH}$  showed that the reaction proceeds by elimination of  $\text{SO}_3\text{Na}$  and addition of  $\text{ONa}$  (Brodkii, Dedusenko, Makolkin, and Miklukhin, J. Chem. Physics, 1943, 11, 342).

The exchange between the oxygen in water and organic compounds has been studied by a large number of workers, a wide variation in the velocity of the exchange being found. For example, with methyl alcohol there was no exchange at  $100^\circ\text{C}$ . for 7 hours, nor at  $25^\circ\text{C}$ . for 24 hours in the presence of acid. Acetaldehyde, on the other hand, was completely exchanged at  $25^\circ\text{C}$ . in 24 hours, by, it is proposed, a mechanism involving the formation of

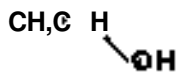

Day and Ingold (J.C.S. 1939, 838), used  $^{18}\text{O}$  to study the mechanism of hydrolysis of carboxylic acids. The heavy oxygen isotopes have also found a use in biological research, e.g., animal respiration was studied using an  $^{18}\text{O}$ -enriched atmosphere, and it was shown that the oxygen enters directly into the carbon oxidation and is exhaled as carbon dioxide (Day and Sheel, Nature, 1938, 142, 917).

#### ATOMIC AND MOLECULAR OXYGEN.

Oxygen exists in four forms, atomic oxygen, consisting of single atoms, normal oxygen, consisting of diatomic molecules, ozone, consisting of triatomic molecules, and a further form containing four oxygen atoms.

Atomic oxygen may be produced by streaming

molecular oxygen at a pressure of about 1 mm. through an electrical discharge. The apparatus is similar to that used for producing and studying atomic hydrogen, the gas passing away from the discharge consisting of a mixture of molecular and atomic oxygen. The recombination of two atoms to form an oxygen molecule and the combination of an atom and a molecule to form ozone can occur only as a three-body collision or on a solid surface, and hence the concentration of ozone in the mixture increases as the temperature is lowered. The energy of activation of the process  $\text{O} + \text{O}_2 = \text{O}_3$ , is only 4 kg.-cal., the reaction between oxygen atoms in a discharge and molecular oxygen at low temperatures being a convenient method of preparing a high concentration of ozone.

An alternative method of producing atomic oxygen is by irradiation with light of some wavelength within the continuous absorption range of oxygen, i.e., of wave-lengths less than 1,900 Å. A condensed spark passed between aluminium electrodes in air will produce light containing this wave-length. The resonance lines of xenon at 1,495 Å. and 1,295 Å., corresponding to 193 and 219 kg.-cal., respectively, also effect the photodissociation of oxygen.

Oxygen can be dissociated thermally, the percentage dissociation at 760 mm. being shown in the following Table (von Wajtenberg, Z. anorg. Chem. 1940, 244, 335; 1938, 238, 299).

T°K.	2,000	2,500	3,000	3,500	4,000
% Atomic oxygen	3.6X10 <sup>-2</sup>	0.85	6.95	24.9	61.0

Dissociation can also occur on a surface of metals, e.g., the dissociation of oxygen on a glowing platinum surface has been shown to have a velocity proportional to the square root of pressure. The heat of dissociation in this reaction is 20,000-30,000 g.-cal. (Mochan, Khim. Beparat. Zhur. 1940, No., 4, 3).

Gauzit (Coiqpt. rend. 194, 213, 695), using spectrographic methods, estimates that a height of 100 km. above the earth's surface the atmosphere consists entirely of atomic nitrogen and oxygen.

The recombination of oxygen atoms is a strongly exothermic reaction, viz.  $\text{O} + \text{O} = \text{O}_2 + 116.4$  kg.-cal. If the recombination is made to occur, for instance, on the surface of platinum metal, the heat of reaction is sufficient to melt the platinum.

The half-life of the oxygen atoms depends on several factors, but is influenced mainly by the presence of foreign gases and the pressure.

The reactions of atomic oxygen have been extensively studied (c/. Geib, Ergebn. exakt. Naturwiss. 1935, 15, 44). With hydrogen the ultimate product is water. This oxidation, carried out in a quartz vessel, has been shown (Pavlyuchenko, J. Phys. Chem. U.S.S.R. 1940, 14, 877) to be a volume reaction, the energy of activation being zero from  $-183^\circ$  to  $0^\circ\text{C}$ , a fact taken to indicate that the effectiveness of collision between oxygen atoms and hydrogen molecules for oxidation, and the collision between oxygen atoms and oxygen molecules for deactivation, is the same. There is, however, still great uncertainty as to the exact mechanism

of the reaction (c/. Kistiakowsky and Smith, J. Amer. Chem. Soc. 1935, 57, 835). Hydrogen sulphide and carbon bisulphide\* both react with atomic oxygen at low pressure with a blue luminescence and the production of S, SO<sub>2</sub>, SO<sub>3</sub>, H<sub>2</sub>SO<sub>4</sub>, H<sub>2</sub>O, CO, and CO<sub>2</sub>. Schenk and Jablonowski (Z. anorg. Chem. 1940, 244, 397), fusing an improved apparatus for the preparation of atomic oxygen, examined the products for ^H<sub>2</sub>SO; none was, however, detected. The reaction of atomic oxygen with carbon monoxide is very slow at room temperature. Nitrogen dioxide at -190°o. reacts vigorously with the production of a green luminescence, to give nitrogen pentoxide. With chlorine the products are primarily chlorine monoxide and chlorine dioxide, whilst with bromine &\*> liquid air temperature atomic oxyge forms in quantitative yield a compound having the composition BrO<sub>2</sub>. With the hydrogen halides, HCl and ^Br^the free halogens are liberated. Carbon tetrachloride .reacts\* with atomic oxygen producing phosgene and chlorine; chloroform produces hydrogen chloride as well, whilst methylene chloride produces hydrogen, water, hydrogen chloride, chlorine, carbon monoxide, carbon dioxide, and phosgene. Methyl chloride reacts only slowly. All hydrocarbons are attacked more or less slowly, the reaction being accompanied by luminescence, the spectnim of which shows OH, CH, and sometimes CC bands. At low temperatures atomic oxygen takes part in addition reactions with unsaturated compounds; thus by reaction with acetylene a substance of composition C<sub>2</sub>H<sub>2</sub>O<sub>2</sub>' is formed, which decomposes at temperatures above -90°c, producing water, formic acid, and glyoxal, together 'n/ a little carbon dioxide, benzene reacts at -80°o. with atomic oxygen, täre Oxygen atoms per molecule being added, whereas above -30°c. the product decomposes into products similar to, those obtained from the analogous reaction with acetylene. An ex-plosive substance is obtained by reaction of atomic oxygen with ammonia. Hydrogen hydride and ^y nitrogen react with emission of "gat, the spectrum of which shows CN bands. WSK pr Sh etc are mainly carbon monoxide, carbon dioxide, water, and nitrogen.

3 5 S f and Nic&ola (Physical Rev. 1930, [ii], in»»t? .-? Ve shown that molybdenum trioxide the pr ^d«j Ued by the action of atomic oxy«en; GavHon, W nofurfcher educed by hydrogen. fiW«k. ^ y ^ g ^ e continuous spectra of laße rôle in processes of combustion (Proc. Roy. Soc. 1844, A, 153, lli).

The tetra-atomic oxygen m<>^ule we\* first postulated by Harris (Chem t g. 1907, 31, 609), who . ^ rro it 'oxoz one, which he claimed was ^ T. S POUnd of \*».\* activity, present in appreciaS quantities in MI and Riesenfeld and Schwab F\*\*\*, 1922 » [B]. 1908), who succeeded in preparin p or s\*\*TMTM', liquid, and solid o. One have stated that no evidence T. It8 uxi8teilee. Spectroscopic stantiate the L. n broug't forward to sub-Heller considers - molecule as a quasi- or van

der Waals molecule (J. Chem. Physics, 1941, 9, 154). That (O<sub>2</sub>)<sub>2</sub> molecules exist in gaseous oxygen as well as in the liquid and solid phases follows conclusively from the observed continuous absorption bands of the (O<sub>2</sub>)<sub>2</sub> molecule. Some of these bands are responsible for the pale blue colour of compressed, liquid, and solid oxygen. The spectroscopic evidence is corroborated by the results of a good many other investigations, namely the departure of oxygen from the reduced equation of state, the anomalous Faraday effect, the deviation from Curie's Law of paranjagnetism, the Cotton-Mouton effect, the structure of y-oxygen, and the magnetic susceptibility. The O—O distances are 1.21 A. and 3.48 A., the atoms separated by the shorter distance being tightly bound by normal valency forces, and the pairs of atoms separated by the larger distance by intermolecular foress, probably of the nature of the Heitler-London dispersion force. From data obtained from the deviations of liquid oxygen from Curie's Law of paramagnetism the fraction by weight of the dimer in the undiluted substance has been calculated by Lewis (J. Amer. Chem. Soc. 1924, 46, 2027) to be 40% at 77°x., and, by extrapolation, 0.03% at 293°K. and 1 atm. Guillien (Compt. rend. 1936, 202, 1373), by making use of the concentration dependence of the extinction coefficient, has confirmed the value of 40% of (O<sub>2</sub>)<sub>2</sub> at 717°K.

RADIOOHEMISTRY.

Two radioactive isotopes of oxygen can be produced, <sup>16</sup>O, which is 0+ active with a half-life of 126 sec. and <sup>19</sup>O, which is β- active with a half-life of 31 sec. <sup>15</sup>O has been produced by the following reactions: <sup>14</sup>N(a,n)<sup>16</sup>O; <sup>16</sup>O(y,n)<sup>16</sup>O; <sup>14</sup>O(n,2n)<sup>15</sup>O; <sup>14</sup>N(p,γ)<sup>14</sup>O; <sup>13</sup>C(a,β)<sup>16</sup>O; <sup>19</sup>O has been produced only by the reaction <sup>19</sup>F(n,p)<sup>19</sup>O (c/. Seaborg, Chem. Rev. 1940, 27, 199).

Oxygen undergoes various particle-capture reactions, «O(i,α)<sup>16</sup>N; <sup>18</sup>O(a,n)<sup>18</sup>F (Welles, Physical Rev. 1941, [ii], 59, 679). The reaction <sup>16</sup>O(o,y)<sup>18</sup>F has been suggested but not confirmed. Zagor and Valente (ibid. 1945, [ii], 67, 133) report the reaction <sup>20</sup>Ne(α,a)<sup>17</sup>O.

CHEMICAL PROPERTIES.

Oxygen is normally a divalent element, the inter-bond angles varying from 100±3° in F<sub>2</sub>O to 118±3° in ^-di-iodophenyl ether. In ethylene oxide the oxygen is under strain and submits to a bond angle of 60 ±2°. Friedel in 1875 showed that ethers, e.g., (CH<sub>3</sub>)<sub>2</sub>O, could form unstable salts of the form [(CH<sub>3</sub>)<sub>2</sub>OX]+Y- with acids, e.g., HCl, and with methyl iodide. More stable salts such as those from compounds of the dimethyl pyrone type:

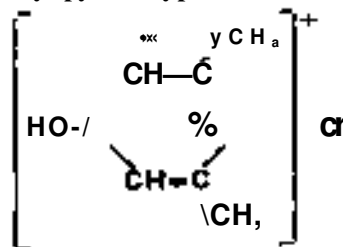

have been prepared.

It is now generally recognised that the proton is far too unstable to exist free in contact with water, and that it exists in the form of the hydroxonium ion,  $H_3O^+$ .

The compounds in which oxygen is tetra-valent are known as oxonium salts. X-Ray analysis of basic beryllium acetate has shown that the four valencies of the central oxygen atom are tetrahedrally distributed in space.

Oxygen ions,  $O''$ , exist only in the crystal lattice. The oxygen molecule-ion,  $O_2'$ , present in superoxides, e.g.,  $KO_2$ , presents an interesting example of an ion possessing an unpaired electron. It is deeply coloured and paramagnetic. The  $O_a''$  ion is present in the peroxides possessing the simple structure  $O'-O'$ .

The congeners of oxygen in the sixth group of the Mendeleef classification of the elements are chromium, molybdenum, tungsten, and uranium in the A sub-group, and sulphur, selenium, tellurium, and polonium in the B sub-group. The A sub-group bears no relationship to oxygen, but some of the compounds of sulphur, selenium, and tellurium are analogous to those of oxygen, e.g., sulphides.

The great chemical activity of oxygen is a commonly encountered phenomenon, especially in the processes of combustion. Oxygen combines directly with most elements under suitable physical conditions. In many of these reactions sufficient energy is evolved to heat the products to the point of incandescence, as in the familiar burning of carbon in air. The slowness of many reactions involving oxygen is doubtless connected with the large energy required to dissociate the oxygen molecule into atoms. All elements, with the exception of the inert gases, combine indirectly with oxygen.

The metals and oxygen react with varying affinity; no metals in the massive state react appreciably at ordinary temperatures, but surface oxidation does occur very slowly in the case of a few. Finely divided metals, e.g., those in the pyrophoric state, are usually spontaneously inflammable in oxygen. Moist oxygen, on the other hand, reacts with a large number of metals at room temperature. Metals such as sodium, potassium, calcium, and magnesium combine readily with oxygen on heating, the reaction being accompanied by an evolution of heat and light. Iron can be made to burn in oxygen if it is in the form of steel wool or of fine wire, and is previously raised to a suitably high temperature. The burning of metals in oxygen gives rise to various oxides, according to the amount of oxygen present; thus for instance, sodium gives sodium oxide,  $Na_2O$ , in a deficiency of oxygen, and sodium peroxide,  $Na_2O_2$ , in excess of oxygen. Potassium in excess of oxygen results in the formation of the oxide  $KO_2$ . If the oxide is unstable at the temperature necessary for reaction it will not be formed directly, even though much heat be evolved in the formation of the oxide. This is true in the case of the oxides of silver, gold, platinum, and palladium. However, the platinum metals in the form of foil, or in the spongy state, combine with oxygen to give a thin layer of black oxide.

The non-metals, with the exception of the halogens, combine readily with oxygen at various

temperatures. Phosphorus, sulphur, and carbon burn readily in pure oxygen on warming to give acidic oxides. Nitrogen absorbs energy when it unites with oxygen, and consequently the oxide is formed only at a very high temperature. The oxides of chlorine, bromine, and iodine are not formed by direct reaction with oxygen; however, by passing a mixture of fluorine and oxygen through an electric discharge, oxides of fluorine have been obtained. The halogens react with ozone to give oxides under varying physical conditions. A jet of hydrogen will burn quite readily in oxygen and even if placed below the surface of liquid oxygen will continue to burn. Liquid oxygen is without effect on the majority of non-metals, though graphite and diamond when once ignited will continue to burn on the surface of the liquid, with the result of formation of liquid ozone and solid carbon dioxide.

The compounds of oxygen with the metals and non-metals may be divided into several types considered below.

1. *Basic Oxides*.—It is characteristic of the metallic elements that each forms at least one oxide which will react with acids to produce salts, the valency of the metal remaining unaltered, e.g.,  $CuO$ ,  $Na_2O$ .

2. *Acidic Oxides*, often termed anhydrides, are derived from non-metals, e.g.,  $SO_2$ ,  $N_2O_5$ , but may include certain of the higher oxides of some metals, e.g.,  $CrO_3$ ,  $Mn_2O_7$ . It is characteristic of these oxides that they combine with water to form acids. Unlike the basic oxides, an acidic oxide rarely adds sufficient water to convert all its oxygen atoms into hydroxyl groups, e.g.,

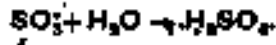

It is, however, sometimes possible to prepare organic derivatives of the completely hydroxylated ("ortho") acid.

3. *Mixed Oxides*.—In some cases acidic oxides are encountered which give, on reaction with water, a mixture of two acids; these are termed mixed oxides, e.g.,

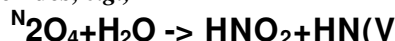

Some basic oxides behave in a similar manner giving a mixture of salts of the metal in two valency states, e.g.,



4. *Neutral Oxides*.—This class of oxides is small, and includes all the oxides which do not belong to one of the other classes named. They do not combine with water to form acids, nor do they neutralise acids. Water, carbon monoxide, and nitrous oxide are examples of such compounds. Carbon monoxide and nitrous oxide are formed from formic acid and hyponitrous acids, respectively, by loss of water, but, although they do not unite with water to form these acids, their relationship to them is such that they cannot be considered neutral oxides in the narrower sense.

5. *Amphoteric Oxides*.—These are capable of functioning either as basic or as acidic oxides, e.g., aluminium oxide is soluble in alkalis, with the production of sodium or potassium alumi-

ate, Na<sub>2</sub>Al<sub>2</sub>O<sub>4</sub>, and it may also be dissolved in acids with formation of ter^alent aluminium salts. Zinc and tinoare two other comm&nly encountered metals possessing oxides with amphotetic properties.

6. Peroxides.—These contain the corresponding peroxide ions, consisting of oxygen molecules bearing a double negative charge, thus: O'-O'. The action of acids on these peroxides is to produce hydrogen peroxide and the corresponding salt. The peroxides are characterised by the oxygen-oxygen bridge.

The methods for preparing individual oxides may be generalised into the following commonly employed methods:

- (1) Direct reaction of the element with oxygen.
- (2) Decomposition of nitrates, chlorates, etc.,



- (3) Decomposition of Carbonates, e.g.,  
 $CaCO_3 \rightarrow CaO + CO_2$
- (4) Precipitation of the hydroxide and subsequent ignition to the oxide.
- (5) Dehydration of an oxyacid.

As has been referred to in an earlier section of this article, molten silver, platinum, and palladium absorb oxygen to give a solution of the gas in the metal; the majority of the gas is evolved on cooling. This may be regarded as a chemical reaction leading to the formation of oxide which is appreciably soluble at elevated temperatures.

Non-stoichiometric oxides are formed in the case of several of the metals with variable valency. Thus the lower oxides of iron, cobalt, and nickel show which is normally described as a limited range of solid solutions of the higher oxides. The instability of the non-stoichiometric oxide has been demonstrated by Hagg (Nature, 1923, 181, 167). The stoichiometry of this oxide has been investigated magnetically by Klemm and Hass (Z. anorg. Chem., 1934, 219, 82), who showed that the susceptibility of nickel oxide prepared by irradiation of the carbonate showed great variation, being dependent on the field strength and characteristic of ferromagnetic materials. The Curie point was the same as that of metallic nickel. When a compound having the stoichiometric composition

constant value, independent of position, is thus plain that the limiting composition of stable NiO is Ni<sub>1-005</sub>O. This is unstable, undergoing transition into NiO.

non-stoichiometric oxides are semi-conductors. In the case of peroxide, the oxygen interstitially is present. Presence of oxygen atoms in the lattice and, the conductivity is apparently due to the

Other compounds containing varying amounts of oxygen are known. Most notable amongst these are the tungsten oxides, which occur during the reduction of tungsten oxide by hydrogen in the absence of basic oxides. The resulting product, which contains a small amount of hydrogen, has been shown to have a variable composition depending on the experimental conditions employed.

Graphite can be oxidised by the action of strong oxidising agents, such as nitric acid and potassium chlorate. The graphite swells in one crystallographic direction only, whilst both oxygen and hydrogen are taken up into the lattice. The eventual product varies in colour from green to brown according to the conditions. This variation in composition, and the accompanying variation in colour, led to the belief that a number of compounds are formed, called graphitic oxides. Measurements of the distance between successive graphite sheets in these compounds show that it increases from the value 3.45 A. in graphite itself to values between 6 and 11 A., and that this expansion in spacing follows the increasing oxygen content. It appears that the oxygen atoms are attached to both sides of the carbon sheets, the carbon: oxygen ratio varying between 2.9 and 3.5 to 1.

The thermal stability of the metallic oxides varies greatly between the most electropositive and the most electronegative. The alkali metal oxides are volatile at high temperatures; except in the case of lithium hydroxide, the action of heat on the hydroxides will not result in the formation of the oxides of the metals. The oxides of the alkaline-earth metals are utilised as refractories, the boiling-point of magnesium oxide being about 2,800°. When strongly heated, the oxides of the alkaline earths, and also those of certain other metals, notably thorium and zinc, become strongly incandescent. The basic oxides of the heavy metals are decomposed into their elements only at very high temperatures. Cuprous oxide is the most easily decomposed (1,935°K., under the partial pressure of oxygen in the air). The dissociation pressures of the oxides of iron, cobalt, nickel, copper, manganese, tin, and tungsten have been determined by Wohler and Balz (Z. Elektrochem. 1921, 27, 406), by utilisation of the reaction; metal-water oxide+hydrogen. The oxides of the noble metals are readily decomposed on heating into the metal and oxygen, intermediate oxides in which the metal assumes a lower valency state occurring as intermediates. It is thus usual to prepare the oxides of the noble metals by indirect routes. Silver and aurio oxides may be decomposed photochemically.

Many substances are oxidised at ordinary temperatures, e.g., nitric oxide, ferrous and manganous hydroxides, etc. In some cases the oxidation is so vigorous that the heat developed inflames the mass. This is the case, for instance, with hydrogen phosphide, P<sub>3</sub>H<sub>4</sub>, silicon and boron hydrides, zinc ethyl, etc.

The oxidation processes which take place with the emission of light are usually referred to generally as combustion or "burning." Two main theories of combustion have been put forward. Many of the investigations in this field

have been based on hydrocarbon oxidation. Bone, to whom much of the early work on the chemistry of hydrocarbon combustion is due, proposed a hydroxylation mechanism, which, in the case of ethylene, may be represented as follows:

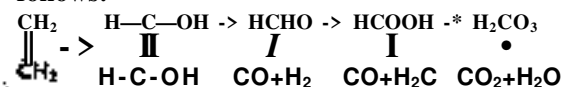

If these changes are assumed to occur, the varied relationships between the possible products can be adequately explained. It is now generally accepted that the oxidation of hydrocarbons takes place through the formation of peroxides and hydroperoxides. In ordinary cases of oxidation the peroxides are only formed at temperatures where their survival is unlikely. These intermediate peroxidic compounds have been detected in combustion at an early point in the cycle of an internal-combustion engine. The oxidation of hydrocarbons is undoubtedly a chain reaction involving free radicals as carriers. (For further information on modern developments in the subject of oxidation, see Symposium on Oxidation, Trans. Faraday Soc. 1946, 42, 99.)

Oxidising agents, and particularly peroxidic compounds, are the commonly employed catalysts for the polymerisation of ethylenic monomers, including such compounds as styrene, acrylic acid, etc. Silicone resins may further polymerise by aerial oxidation of methyl groups attached directly to silicon atoms, the oxidation resulting in the formation of a further cross linkage.

The term "corrosion" is given generally to processes involving the formation of metal oxide films (see Evans, J.C.S. 1946, 207).

The process of respiration in animals involves the absorption of oxygen through the lungs, the transfer of this oxygen by the blood to the cells, and the uptake of carbon dioxide by the blood, with its ultimate elimination through the lungs. The uptake of oxygen by the blood does not follow Henry's Law for gas solubility, the absorption being, in fact, a chemical reaction between the haemoglobin of the cells and oxygen, resulting in the formation of oxyhaemoglobin. The nature of the respiratory process as one of "slow combustion" was recognised by Lavoisier; it is the heat evolved from this oxidation of organic matter that maintains the body temperature. Oxygen is necessary for all forms of life, excepting certain of the lower forms, which are hence termed "anaerobic." Normally, pure oxygen is detrimental to the continued health of animals, although in certain cases the administration of pure oxygen is necessary for medical reasons.

Bean (Physiol. Rev. 1945, 25, 1) and Bean and Siegfried (Amer. J. Physiol. 1945, 143, 656) report that oxygen at high pressures is toxic to animals.

#### DETECTION AND DETERMINATION.

Qualitatively, the simplest test for gaseous oxygen is the rekindling of a glowing splint of wood, a property possessed by no other gas only, viz. nitrous oxide. A mixture of air and oxygen containing less than 30% of oxygen does

not ignite a glowing splint. When mixed with colourless nitric oxide, oxygen produces deep reddish-brown nitrogen dioxide, whereas nitrous oxide does not. Nitrous oxide is also considerably more soluble in cold water than is oxygen. Oxygen reacts with a solution of pyrogallol in potassium hydroxide, which should be nearly colourless, to give a dark brown coloration. Ferrous sulphate and catechol mixed in an alkaline solution rapidly absorb oxygen with the production of a deep red colour. White indigo absorbs oxygen rapidly, the product being blue.

For the quantitative determination of gaseous oxygen methods of absorption and combustion and several physical methods are available. The absorption of oxygen can be readily carried out in an ordinary gas analysis apparatus, such as the Orsat or Hempel apparatus. The following absorbents are in general use:

1. *Potassium or Sodium Pyrogallate Solution*.—These solutions absorb oxygen rapidly when fresh. The reagent consists of two stock solutions, (i), containing 600 g. of potassium hydroxide in 1 litre of water, and (ii) containing 300 g. of pyrogallol (1:2:3-trihydroxybenzene), in 1 litre of water. (Pyrogallol is often referred to as pyrogallic acid.) For use 50 ml. of the pyrogallol solution is mixed with 175 ml. of the potassium hydroxide solution. In the case of sodium pyrogallate, 60 ml. of the pyrogallol solution described above is mixed with 150 ml. of 50% sodium hydroxide solution. The mixed solution should be kept in a stoppered vessel to avoid contact with air. Care must be taken with the use of this reagent, especially the sodium pyrogallate, since high concentrations of oxygen combined with low concentrations of alkali result in the evolution of carbon monoxide from the reagent. When the concentrations described above are used, 1 ml. should absorb 8-10 ml. of oxygen readily before renewal.

2. *Ammoniacal Copper*.—Clean moist copper absorbs oxygen freely, but a film of oxide is rapidly formed over the copper, which prevents further oxidation. An ammoniacal solution of ammonium carbonate readily dissolves the oxide, leaving a clean copper surface. The reagent is best prepared by treating pieces of copper or copper gauze, cleaned with nitric acid, with 500 ml. of a saturated solution of ammonium carbonate and an equal quantity of concentrated ammonium hydroxide. To utilise this reaction for analysis a suitable absorption vessel is packed with pieces of copper or copper gauze, which is then covered with the ammoniacal solution. When the gas enters the vessel the solution is displaced, leaving a clean copper surface, which absorbs the oxygen. The gas may then be removed by allowing the solution to return to the absorption vessel and remove the oxide layer. This process may be repeated many times if necessary. The reaction can be used for the continuous absorption of oxygen, the gas passing up a tower packed with clean copper gauze, down which a stream of the ammoniacal solution is allowed to flow. After continual use a yellowish-brown precipitate forms which necessitates cleaning of the apparatus. Gases such as carbon monoxide and ethylene must be absent for this determination.

3'. *Yellow Phosphorus*.—The absorption of oxygen by means of phosphorus takes place by allowing the gas containing the oxygen to remain over moist phosphorus. The formation of white clouds indicates the presence of oxygen, and their disappearance shows that the absorption is complete. If the gas contains more than 60% of oxygen, moist phosphorus will not absorb it at normal pressures, and in this case the gas must be diluted with either nitrogen or hydrogen, until the mixture contains less than 60% of oxygen; alternatively it may be allowed to react with phosphorus under reduced pressure, but in this case the reaction may be rather vigorous. The presence of traces of heavy hydrocarbons, ethereal oils, alcohols, or ammonia results in the prevention of absorption. The phosphorus is usually used in the form of small sticks, 4-6 mm. in diameter, in the usual Orsat apparatus. The oxidation of phosphorus is slow unless carried out in a warm atmosphere. The use of phosphorus in the Orsat apparatus is not to be recommended owing to the danger of explosion and fire.

4. *Chromous Chloride*.—Although this reagent is one of the most rapid absorbents for oxygen and has been in use for nearly fifty years, it has not become popular because it is difficult to prepare and keep in the reduced state. Stable solutions in quantities sufficient to charge a pipette may be prepared best by reducing chromic chloride in a Jones reductor containing amalgamated zinc. It does not absorb hydrogen sulphide or carbon dioxide. A standard solution of chromous chloride, called "oxsorbent" has been used with success.

*Alkaline Sodium Hyposulphite*.—The reaction occurring on the absorption of oxygen with this reagent is:

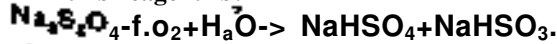

The absorption is slower than with alkaline Pyrogallol, but takes place at much lower temperatures; further, no interference due to the presence of carbon monoxide or absorption of unsaturated hydrocarbons is encountered. A suitable reagent is prepared by dissolving 50 g. of sodium hyposulphite in 250 ml. of water and adding 20 ml. of sodium hydroxide in 40 ml. of water to make 600 ml. solutions. The rate of absorption is greatly increased by the addition of sodium anthraquinone-8-sulphonate.

Several methods exist, of which only one will be mentioned, in which the oxygen is absorbed and the resulting products (or the remaining unreacted reagent) determined by normal analytical methods. Oxygen can be absorbed in small quantities in a solution of manganous hydroxide, which is freshly precipitated from a manganous chloride solution. On contact with oxygen the following reaction occurs:

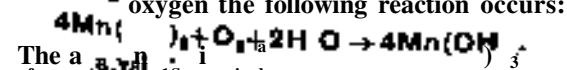

The reaction is carried out in a Bunte burette; after the absorption is complete, excess of a solution of potassium iodide is added to the burette, and the iodine liberated by the reaction with sodium thiosulphate solution:

$$2Mn(OH)_3 + 2I^- + 2H^+ \rightarrow 2Mn(OH)_2 + I_2 + 6H_2O$$

1 ml. of 0.1N. sodium thiosulphate solution is equivalent to 0.560 ml. of oxygen at N.T.P. Winkler (Ber. 1888, 21, 2843) used this method for the determination of oxygen absorbed in water. The sample of water is shaken with manganous hydroxide, prepared *in situ* from manganous chloride and alkali, and the amount of dissolved oxygen determined by the addition of hydrochloric acid and potassium iodide and the subsequent titration of the liberated iodine.

In the absence of combustible gases in the gas mixture oxygen may be determined by explosion with a known volume of hydrogen and subsequent measurement of the contraction in volume. A small explosion pipette, suitably screened and containing sealed-in platinum wires connected to an induction coil, is used.

Oxygen can be determined colorimetrically by absorption in ammoniacal cuprous chloride solution. The resulting oxidation to the cupric complex results in the formation of a blue coloration, the intensity of which is directly proportional to the amount of oxygen absorbed. This method can be used directly for the determination of dissolved oxygen, although a correction for the colour of the original solution must be made. Gaseous oxygen may be determined colorimetrically by its interaction with manganous hydroxide in the presence of potassium iodide. After acidification, in the presence of starch, the blue colour of the starch-iodine complex is used for comparison with standards. Using this method it is possible to detect 0.15 p.p.m. by volume of oxygen. Colorimetric methods, based on the colour produced with "Adurol" (a chloro-derivative of hydroquinone) (Winkler, Z. angew. Chem. 1913, 26, 134), pyrogallol, and the leuco-base of indigo carmine, have also been used.

A method for the detection of traces of oxygen has been proposed in which the faint blue fluorescence obtained in the photolysis of acetone in the presence of a trace of oxygen is utilised (Damon, Ind. Eng. Chem. [Anal.], 1935, 7, 133). By means of the destruction of the phosphorescence of tryptaflavine absorbates, oxygen can be detected at pressures as low as 0.0005 mm. As absorbent, gels of highly polymerised inorganic acids are suitable, whilst the most suitable dyes are tryptaflavine, euchryin 3R, and uranin (Kautsky and Hirsch, Z. anorg. Chem. 1935, 222, 126).

Several automatic devices are described in the literature for the estimation of oxygen in industrial gases. The majority of these instruments depend on the application of thermal conductivity measurements of gas mixtures, the instruments being calibrated against mixtures of known composition. A recording mass spectrograph is described for the determination of mixtures of oxygen, carbon monoxide, and carbon dioxide (Amer. Chem. Abstr. 1945, 39, 3471).

An interesting instrument, the use of which, as an oxygen meter, depends on the fact that the magnetic susceptibility of oxygen is very much greater than that of other common gases, has been described by Ruling, Wood, and Sturdivant (J. Amer. Chem. Soc. 1946, 68, 795).

The determination of combined oxygen »



difficult and seldom attempted. If the presence of oxygen has been definitely established it may often be estimated by difference after determination of the other constituents present. In certain cases of inorganic compounds, where the oxygen atoms are reactive, special analytical methods exist. The oxygen in oxides can in some cases be determined as follows: nitrogen free from oxygen is passed over sulphur at 200°C. and then over the oxide, heated to 1,000°C. The resulting sulphur dioxide is absorbed in potassium iodate-iodide mixture in acid solution, when it is oxidised to the sulphate ion by the iodine. The remaining iodine is then titrated with sodium thiosulphate solution. The method has been shown to give results within 0.1% in the case of zinc oxide, and from theoretical considerations it should work with a number of oxides. It does not apply, however, to silicon, boron, aluminium, beryllium, or magnesium oxides (von Wartenburg, Z. anorg. Chem. 1943, 251,161).

Although oxygen is one of the most commonly occurring constituents of organic compounds, and although methods for its direct determination have been the subject of extensive research, this element is still most frequently determined by difference. It is apparent that the methods so far made available for its direct determination are not wholly satisfactory, for if this were not the case, it is certain that they would have been more widely applied in preference to a determination by difference. The determination by difference places the sum of all the errors upon the oxygen value, and eliminates the possibility of checking the analysis; the results become even more unsatisfactory with increasingly complex molecules containing several elements. A very large number of papers have been published, but no satisfactory method has yet been evolved. The subject has been fully reviewed by Elving and Ligett (Chem. Rev. 1944,34,129). The methods so far proposed may be classified as follows:

1. Methods depending on complete oxidation, (a) Dry oxidation using an inorganic oxidising agent such as potassium chlorate, cupric oxide, silver iodate, or potassium dichromate. (b) Wet oxidation making use of silver iodate-sulphuric acid or potassium dichromate mixtures, (c) Combination with a known volume of oxygen. This method has been extensively studied, and a microtechnique developed. Details of the apparatus are given by Kirner (Ind. Eng. Chem. [Anal.], 1934, 6, 358). By this method carbon, hydrogen, and oxygen are determined simultaneously with one piece of apparatus.

2. Destructive chlorination resulting in the formation of carbon dioxide, carbon monoxide, and hydrogen chloride, which can be determined by absorption.

3. Methods depending on reduction. (a) The Meulen method of hydrogenation involves three stages: (i) vaporisation of the sample in a stream of hydrogen; (ii) pyrolysis of the compound in the presence of hydrogen at high temperatures; and (iii) hydrogenation of these products in the presence of a nickel catalyst between 300°C. and 400°C. to convert all the oxygen into water, which may be absorbed and

weighed. Several cracking surfaces have been suggested; platinised quartz or asbestos appear to be most commonly employed. The hydrogenation step in which the reactions:

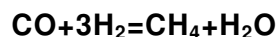
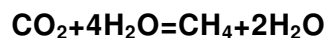

take place can be carried out most satisfactorily on a thoria-nickel catalyst between 300°C. and 400°C. Sulphur tends to poison the catalyst, and hence it is necessary to remove any hydrogen sulphide by passing the gases leaving the cracking surface over nickel. The presence of halogens involves the use of special absorbents. (6) The thermal decomposition of oxygen-containing compounds over carbon at 1,000°C, with production of carbon monoxide and subsequent oxidation of this at room temperature with iodine pentoxide:

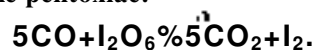

The apparatus is simple and the method has several points to recommend it.

D. S. P.

OXYGEN, APPLICATIONS 9F. The oxy-acetylene flame is being increasingly employed for the descaling of steel billets. High-velocity flames from multi-jet burners are passed over the surface, causing a sudden thermal expansion of the scale not tightly bonded, so that it cracks away from the base metal. The process is cleaner and more economical than the acid bath pickling process.

Such burners are used for cleaning iron and steel surfaces prior to painting. Unbonded scale and other contaminants are removed, leaving a dry, warm surface to which paint adheres more tenaciously to form a coat which is more resistant to corrosion.

Surface hardening of steel components (with carbon content above 0.3%), e.g., wormwheels, sprockets, etc., is accomplished by heating locally with the oxy-acetylene flame and immediately quenching. This gives a hard martensitic structure for the wearing surface of from 1/8 in. to 1/4 in. deep. The normal toughness and ductility of the metal at the core of the component is unaffected.

The low temperature of liquid oxygen is used for the cold treatment of certain tool steels, after the normal heat treatment. It has been found that controlled cooling of the steel confers upon it desirable properties.

The contraction of metal parts effected by immersion in liquid oxygen is utilised in "shrink fitting," e.g., cylinder linings of an internal combustion engine, after cooling, can be readily inserted in their housings, to become a tight fit at atmospheric temperature.

In recent years the use of oxygen for the cutting of steel has been extended by the "desaming" or "desurfacing" process. In semi-finished steel, i.e., in bars, billets, blooms, slabs, or plate, defects usually occur on the surface due to blowholes near the surface of the ingot, or to the rolling-in of scale, etc. In light billets (4 in. x 4 in. or smaller) these defects are seldom more than 1/8 in. deep. Before 1929 such flaws were removed generally by either grinding or

chipping with pneumatic hammers, to avoid a defective finished product. At, about that time & more economical method was perfected, where-in sufficient of the steel in the actual vicinity of the defect was burnt out by oxygen, the groove thus formed being of such shape that the steel could be satisfactorily rolled subsequently. At first, hand-operated torches were used, mainly on cold metal, because of the difficulty of locating defects on hot metal. Then machines were constructed (in America) for skinning cold metal and, ultimately, in the interests of economy, for completely skinning hot metal between actual rolling operations at the mill. Up to  $\frac{1}{8}$  in. depth of metal is cut away from each surface (two or four simultaneously) by these machines, which incorporate stationary groups of torches past which the hot steel is made to move at speeds varying from 75 to 175 ft. per min. From 2\*7? to 4.5 cu. ft. of oxygen, are required for each square foot of steel desurfaced, depend-

ing on the depth of cut, the carbon content of the steel, composition of steel if an alloy, etc. When the machine is in operation, therefore, the rate of consumption of oxygen is very high; suitable large supplies of the gas are readily provided by the "cold evaporator."

The cold evaporator (Fig. 1) is essentially a storage tank constructed for working pressures up to 300 lb. per sq. in., provided with means for controlled discharge of its contents against pressures varying up to the maximum, and having safety devices and measuring arrangements. It consists of a two-piece bronze sphere A forming the pressure vessel, usually with a centre-bolted joint. A thin copper lining, B, concentric with the sphere and open at the top, is supported out of contact with the sphere by asbestos strips; it is the liquid oxygen container proper, and permits filling with the minimum loss by evaporation, even when the massive pressure vessel is in the warm condition.

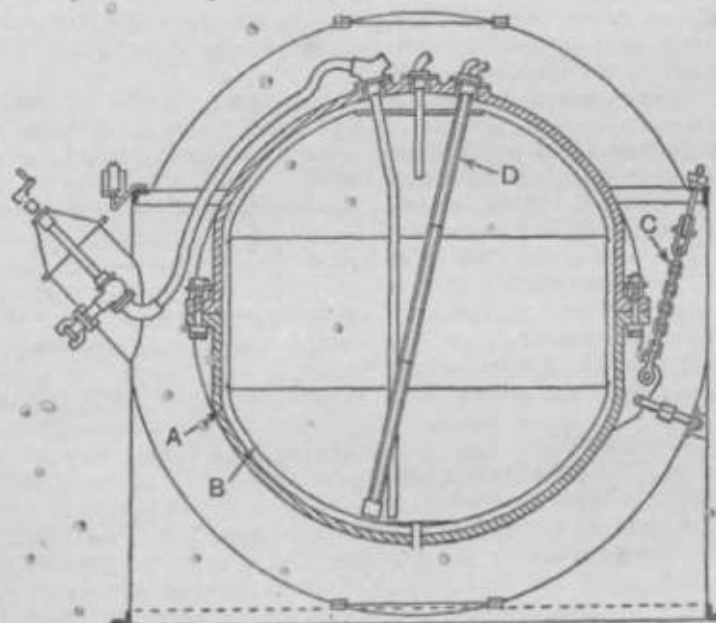

Fig. 1.

It holds the equivalent of 30,000-47,000 cu. ft. of oxygen. It is heat-insulated by a layer of powdered magnesium carbonate, and suspended from the outer casing.

Liquid is forced from the evaporator, by gas pressure, through a coil immersed in water (not shown). By a system of control valves the evaporator can be operated to suit various work-requirements: the evaporation rate and pressure can be varied as required, to suit the demands on the supply line. The gas pressure over the liquid in the evaporator can be kept low by returning the evaporated gas to the evaporator.

Gas jets, immersed in the liquid oxygen, are included to receive the heat during periods, e.g., during which a supply of gas is required for continuous operation.

The amount of oxygen supplied to industry is steadily increased during

the last ten years, especially in areas where steelworks are located, and where large quantities of gas are used at the individual works. About eight times as much oxygen can be carried as liquid as could be sent in cylinders on a lorry of the same capacity, and such economy in transport becomes of vital importance.

Considerable progress has been made in Germany in the development of processes to permit the continuous gasification of solid fuels, to avoid the intermittent nature of the well-known water-gas plants. This has been possible because the low cost of oxygen produced by large plants incorporating the Frankl cold regenerator (v. this Vol., p. 188d).

For the continuous gasification of solid fuel, oxygen is admixed with the steam-blast to maintain the fuel-bed temperature sufficiently high to allow the water-gas reaction to proceed without interruption. In the Winkler producer pulverised fuel is used, and the blast is so adjusted that the fuel bed is constantly agitated

to ensure extreme intimacy of contact between the gases and the fuel. The Lurgi producer operates under pressure, up to 20 atm., and yields a gas having a good calorific value (about 500 B.Th.U. per cu. ft.), making it suitable as town gas, and also a carbon monoxide hydrogen ratio of 1:2, making it suitable as synthesis gas (e.g., for methanol and liquid fuel).

In Russia the gasification of coal is being carried out underground in the seam. In the first instance two inclined shafts were driven down to the coal seams, the shafts being connected by a horizontal working. An air blast (sometimes enriched in oxygen and sometimes containing steam) is forced underground from the surface along one of the inclined shafts, and the gas generated by its action on the white-hot coal is forced to the surface through the second shaft. More recently a number of bore-holes were merely drilled down to the coal seam, and connected underground, all the work being conducted from the surface.

In Belgium, where coal seams are too thin to be worked economically, it is planned to apply the same process, to gasify the fuel in situ by injecting a mixture of oxygen, steam, and carbon dioxide.

Finally, the V2 long-range rocket is of interest because of its enormous rate of consumption of oxygen. The thrust driving the rocket is provided by a jet of very high-velocity gas issuing from the nozzle of a combustion chamber. The gas is the product of the combustion of alcohol in oxygen. Five tons of liquid oxygen are carried on the rocket, and the whole of it is consumed in the first minute of the rocket's flight—130,000 cu. ft. of gas in one minute!

**OXYGEN, PRODUCTION OF.**

The oxygen industry was undoubtedly founded in 1886, when the British Oxygen Company was established as the British Oxygen Company to take over a process for the production of oxygen, patented by two French brothers whose name was adopted as the title of the Company. The Brin process was based on Boussingault's discovery in 1851, that at a temperature of about 540°C. the monoxide of barium would absorb oxygen readily from the air with the formation of the dioxide, and that at a higher temperature (about 870°C.) the oxygen thus absorbed would be given off again, and the barium restored to the monoxide condition ready for the cycle to be repeated. The great loss of time and difficulties involved in the alternate heating and cooling of the barium oxide, however, rendered the process far from economic. It became an established success when the operations of oxidation and deoxidation were carried out at one temperature (650°C), being governed by variation in the gas pressure about the barium oxide, in plant rendered automatic by K. S. Murray.

The process was exclusively employed by the British-Oxygen Company for nearly 20 years in their London, Birmingham, Manchester, and Glasgow factories, and a considerable number of plants, varying in capacity from 5,000 to 30,000 cu. ft. of oxygen per day, were also erected by them to provide oxygen for industrial applications.

**Liquefaction of Air.**—Meanwhile Carl Uncle was working out a totally different method of extracting oxygen from the air, a method destined ultimately to supersede the barium-oxide process. In May, 1895, a machine was set going in the laboratory of the Gesellschaft für Linde's Eismaschinen near Munich, by which it was possible to liquefy several litres of air per hour. Half a century earlier, Thomson and Joule had demonstrated experimentally that some gases become cooled when expanded without generation of mechanical energy, merely as a consequence of internal work done by the molecules. At pressures of from 1-6 atm., and temperature of 0°C. to about 100°C, air was found to suffer a cooling of about 0-25°C. for each atmosphere drop in pressure. If the initial pressure of the air were raised to 200 atm., the drop in temperature on expansion amounted to about 40°C. It occurred to Linde that if the cold expanded air could be made to cool the compressed air before expansion, the temperature after expansion should fall lower and lower until liquefaction should ensue. By combining nozzle expansion with a counter-current heat exchanger, therefore, success was achieved and air could readily be reduced to the liquid state on a commercial scale (y. also LIQUEFACTION OF GASES, Vol. VII, 333a).

\* The cooling effect by nozzle expansion can be considerably increased if the compressed air is pre-cooled before entering the main interchanges and before expansion, by means of an ordinary refrigerating machine (ammonia machine), which operates relatively very cheaply. For example, if the air is pre-cooled to -30°C., the increase amounts to about 27%. In fact, a considerable economy in power expenditure can be achieved by effecting a partial expansion only of the air, from a higher to a lower pressure. Thus, if we consider expansion from 100 atm. to 10 atm., the cooling effect, being nearly proportional to the drop in pressure, is nearly ten times what it would be by expansion from 10 atm. to 1 atm. On the other hand, the energy required for compression from 1 atm. to 10 atm., and from 10 atm. to 100 atm. is the same, since the energy required varies as the logarithm of the ratio of the pressures. These features were incorporated in Linde's earliest air-liquefaction plants.

The first cylinder of a two-stage compressor compresses air to a pressure of 20-50 atm. The second cylinder reduces the pressure from this to about 300 atm. The high-pressure air flows through the inner pipe of a threefold coil to the expansion valve A, which is being pre-cooled by the air leaving the apparatus in counter-current. Being expanded, part of the air liquefies, while the unliquefied part at 50 atm. goes back to the compressor through the middle pipe of the coil, entering at the connecting pipe between the first and second stages. The liquid produced flows through B, into the vessel c, from which it can be drawn off. The air resulting from the expansion leaves the apparatus through the outer pipe of the counter-current coil. The first-stage cylinder, therefore, has only to compress that amount of air which is taken from the apparatus to the liquid state, plus a certain quantity necessary

cover losses through evaporation, leakage, etc. The air coming from the compressor is pre-cooled in the coil a immersed in a freezing mixture (see Fig. 1)."

In March, 1800, a useful laboratory apparatus, the "Hampeon hquefler" (v. Vol. VII, 330a) is produced by the Brins Oxygen Company.

Separation of Oxygen from Liquid Air.—Parkinson had made the suggestion in 1892 that the oxygen and nitrogen in their liquid mixtures might be separated by utilising their different boiling points. By fractional evaporation Linde effected a partial separation, and put on the market the so-called "Linde air," containing about 50% of oxygen. He obtained this by evaporating liquid air in a vessel A (Fig. 2). The vapours flowed out through the counter-current interchanger B, passing firstly to atmosphere through cock o. When the liquid had

evaporated BO far that the vapours contained the desired percentage of oxygen, cock o was closed and D opened to conduct the gas mixture to the gasholder. The evaporation of the liquid was affected by the condensation of compressed air in a system of tubes B immersed in the liquid, the condensate collecting in F. The necessary heat was supplied by the condensing air itself. When A was empty, F was full. The liquid air in V was then passed into A via valve o, and the process repeated. By fractional evaporation, however, high purity oxygen could not be obtained economically, since too much oxygen was carried away with the more volatile nitrogen.

Lhule Process.—It soon became clear that the demands of industry could only be met by oxygen of higher purity. Linde therefore directed his energies to this goal. In February, 1902, he put forward his solution of the problem

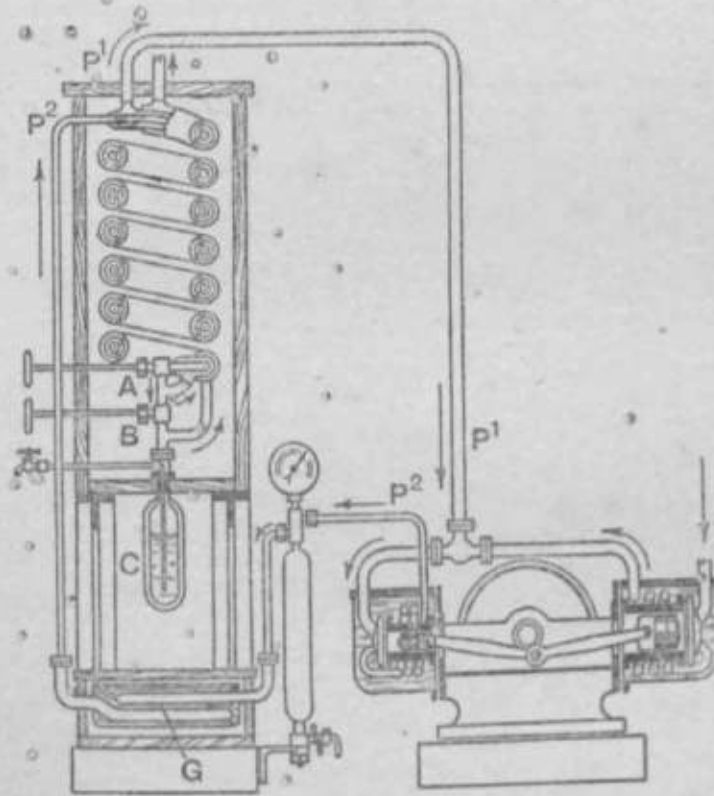

FIG. 1.

by means of rectification. The combination of essential factors consists in (i) effecting the cooling of the compressed air to be liquefied by causing it to flow in counter-current to the cold products of evaporation, (ii) causing the compressed air to transmit its heat of liquefaction to evaporating liquid (liquid oxygen when the liquid is in equilibrium), and then (iii) allowing the vapours produced in the distilling column to flow upwards through liquid oxygen in a rectification column. Other examples of this process are alcohol and water, but air has only been separated by rectification. The application of the process to mixtures of liquid oxygen and liquid nitrogen was far more difficult because of the volatility of the liquids, and the low temperatures at which the process had to be carried out.

Since liquid air was introduced to the top of the rectification column, and since liquid air is in equilibrium with a gas containing 7% of oxygen, the gas mixture issuing from the top of the column contained at least 7% of oxygen, and about two-thirds only of the oxygen could be extracted from the treated air.

The type of apparatus represented by Fig. 3 made its appearance in 1903. The interchanger consisted of coiled copper pipes, five pipes of smaller bore passing through one of larger bore. Compressed air entering at t, after being cooled in the interchange A, was liquefied, while still under pressure, in the coil D immersed in liquid oxygen in the bath O at the base of the rectification column B. It was then expanded through valve v into the top of the column. Liquid air BO introduced at a, temperature of about -110°C,

in passing downwards through transversely disposed perforated metal plates, was brought into contact with vapours rising upwards in the column. These vapours were of nearly pure oxygen at the base of the column, arising from the liquid oxygen boiling in C, at a temperature of about  $-183^{\circ}\text{C}$ . Now a liquid mixture of a certain composition is in equilibrium with a gas mixture having a different composition, and always containing more nitrogen. The rising vapours, therefore, encountered liquids having a lower temperature and differing in composition from the liquids with which they could be in equilibrium. The vapours were warmer and richer in oxygen than equilibrium conditions required. Oxygen vapour therefore progressively

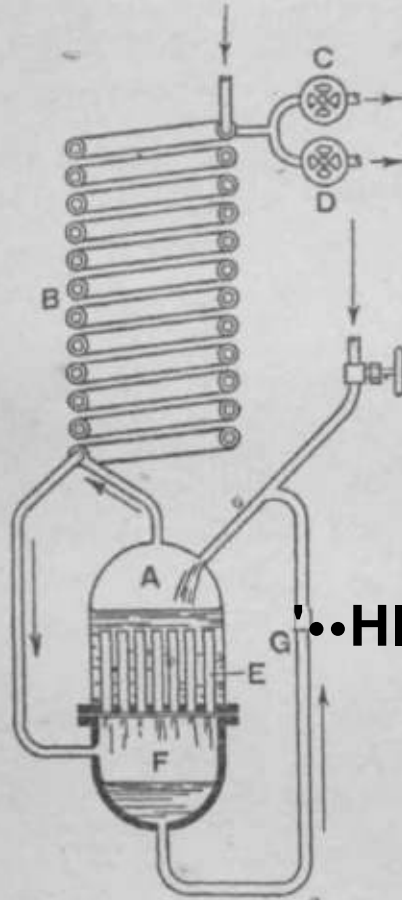

Fig. 2. c

liquefied, and nitrogen liquid evaporated in the effort to attain equilibrium, with the net result that nearly pure oxygen collected at the bottom, whilst a vapour very rich in nitrogen passed off at the top. A certain quantity of oxygen gas could be drawn off through the interchanger to the gasholder.

*Claude Process.*—Meanwhile, Claude had been striving to produce liquid air by expanding compressed air in an engine, with production of external work. Several workers had failed previously to overcome the difficulty of lubrication of the piston at low temperature. In May, 1902, Claude achieved success by using light petroleum in admixture with cylinder oil as lubricant until the temperature had dropped sufficiently for liquid air formation in the cylinder, whereafter

such liquid air was sufficient in itself for lubrication. Since the work obtainable from a compressed gas diminishes with fall in temperature, it was necessary to maintain the temperature of the air entering the engine as high as possible. To this end a second heat interchanger was incorporated in the system, wherein the heat of liquefaction of a part of the compressed air was transmitted to the expanded air, which was thus

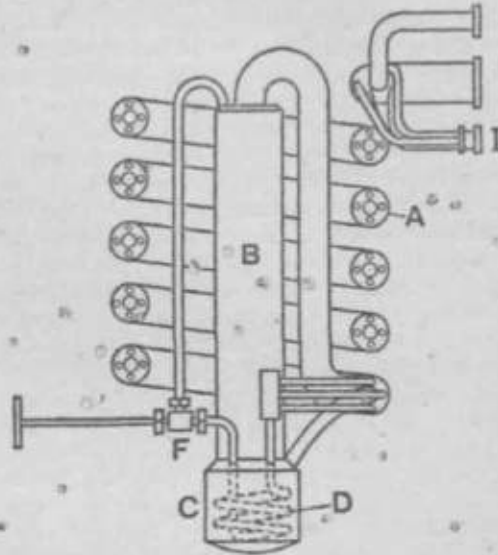

Fig. 3.

unable to cool the feed to the engine to so low a temperature.

As indicated in Fig. 4 the whole of the air feed passed through interchanger  $v$ ; part of it was expanded in the engine  $D$ , and then returned through interchanger  $L$ , in counter-current with the remainder of the compressed air, finally to pass out through the interchanger  $M$ .

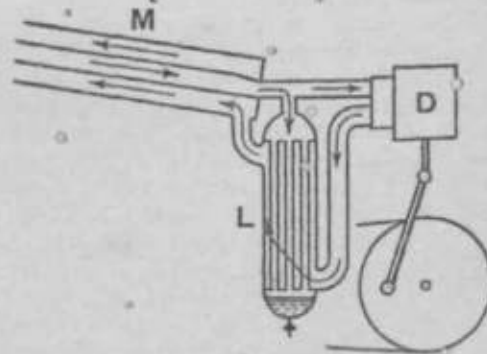

FIG. 4.

Claude coupled the expansion engine to a rectification column, and obtained oxygen by a process similar to that of Linde's, introducing at the same time, however, an improvement which he named the "retour en arriere." Instead of liquefying the compressed air as such, it was divided into two liquids on liquefaction, one containing practically the whole of the oxygen (rich liquid, with about 40% oxygen) and the other containing very little oxygen (poor liquid). The poor liquid, introduced at the top of the



rectification column, could more effectively wash out the oxygen from ascending vapours than could the liquid air of Linde's process, and consequently more than two-thirds of the oxygen in the treated air could be recovered.

The cooled compressed air enters at A (Fig. 5), at a pressure of about 4 atm., and rises up the inner tubes B of the condenser. About half of the air is liquefied, and the liquid falls downwards in the tubes in counter-current to the rising vapours. In so doing it strives to attain equilibrium with the latter, and its oxygen content progressively increases, with the result that a liquid containing about 40% of oxygen collects in A, and is delivered to a suitable point in the rectification column. The uncondensed vapours, very rich in nitrogen, leave the upper ends of the tubes B, and are completely liquefied in the outer tubes c, forming the poor liquid which is admitted to the top of the column.

*Linde Double Column Process.*—About 1910, Linde went a step further, and substituted a pressure

About half of the liquid nitrogen BO produced flows backwards down the pressure column, for the purpose of washing oxygen from the rising vapours, whilst the other half is expanded into the top of the upper column through valve B. The liquid collecting at the bottom of the pressure column has about 40% of oxygen, and is sent to a suitable point in the upper column. The final rectification takes place in the upper column. Pure liquid oxygen collects at the bottom thereof, and about one-fifth of the vapours arising from this boiling liquid are conducted away by F, through a heat interchange to constitute the output from the plant.

*Heylandt Process.*—A modification of the Claude air liquefaction system was introduced by Heylandt about 1913. Part of the compressed air feed at 200 atm., without any pre-

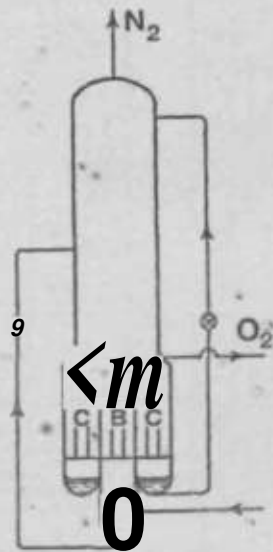

FIG. 6.

rectification column/or the " retour on arriere " contrivance, and constructed the first " double-column " plant. The rich and poor liquids were formed from the treated air in the lower pressure column, and the final rectification was carried out in the upper column. By this method the poor liquid was made still poorer in oxygen, and the separated oxygen and nitrogen obtained in greater purity and yield. The cooled compressed air from the heat interchanger is liquefied in a coil A (Fig. 6) immersed in the liquid bath at the base of the pressure column B, and after expansion valve C is admitted to about the middle of the pressure column. It flows down the column from plate to plate, to the bath at the bottom; vapours rising from the liquid boiling there pass upwards through the plates, and by the time they reach the condenser tubes D at the top, consist of practically pure nitrogen. The pressure in the lower column is sufficiently high (about 5 atm. absolute) to allow these nitrogen vapours to condense in the tubes, which are cooled on the outside by liquid oxygen at slightly above atmospheric pressure-

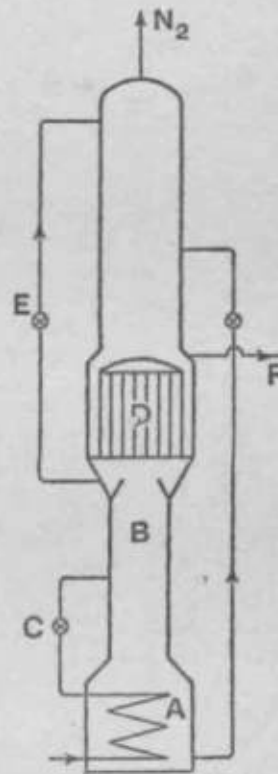

FIG. 6.

cooling, was admitted directly to an expansion machine B (Fig. 7) and expanded in one stage to approximately atmospheric pressure, returning through interchanger A. The remainder of the compressed air was cooled in interchanger A and expanded before nozzle expansion at C. He found that the engine could be fitted with piston rings and lubricated with oil without trouble, since the continuous introduction of warm air sufficed to prevent the cylinder walls from becoming too cold. The modification was useful for liquid air production, though not for gaseous oxygen. For liquid oxygen production, however, it has been successfully developed, as mentioned later.

The double column and " retour on arriere " types of plant were both used for many years for gaseous oxygen production, yielding oxygen of about 98.5% quality. Similar plants could yield nitrogen having a purity of 99.6-99.8%.

Oxygen Purity.—In 1923 efforts were being made to raise the purity of the oxygen by improving the efficiency of the rectification column. Better contact between liquid and vapour was sought by different construction of the rectification plates. These efforts were encouraged by the recognition of the fact that very pure oxygen was advantageous in the cutting of iron, the major application of industrial oxygen. A clean cut was obtainable with a smaller consumption of oxygen. Low quality gas revealed itself in the roughness of the lower section of the kerf, and also by a fringe of partly burned metal on the lower edge, where the final severance of the plate took place. Argon, the main impurity in the gas, took no part in the chemical action with the iron, and consequently increased in concentration as the jet descended the kerf. To-day,

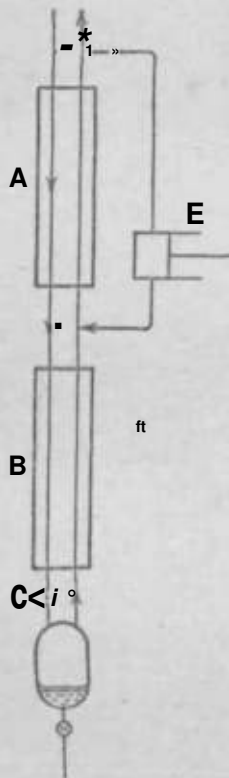

FIG. 7.

plants of the double column type can yield about 95% of the oxygen in the treated air at a purity of 99.5%, or nitrogen containing considerably less than 0.1% of oxygen. From such plants it is possible, by careful adjustment, to obtain 99% oxygen and 99% nitrogen simultaneously. It is difficult, however, to maintain the exact adjustment. The regulation can be facilitated, and both nitrogen and oxygen of high quality can be obtained simultaneously, if a quantity of vapour (about 10% of the air feed), rich in argon, is withdrawn from the upper rectification column at a suitable level. An outlet is thus provided for the greater part of the argon introduced with the air (99.3%), the presence of which renders difficult the main rectification process.

Since a pressure rectification column produces pure liquid nitrogen more readily than the

"retour an arriere" system, the latter has been abandoned and the expansion engines of Claude plants have been coupled to double columns in recent years.

Industrial Oxygen.—In recent years the trend has been to distribute oxygen in the liquid form. Large quantities of the liquid are to-day sent from the production centre to the user's works, there to be converted into gas under pressure.

For plants to produce gaseous oxygen it is only necessary to produce sufficient cold to counteract unavoidable influx of heat to the system through the lagging and via the imperfect heat interchanges. In the case of plants relying upon nozzle expansion, it is possible to lower considerably the starting pressure once running conditions have been obtained. When the oxygen is to be withdrawn as a liquid, however, the much greater cold represented by the lower temperature of the liquid ( $-183^{\circ}\text{C}$ .) has also to

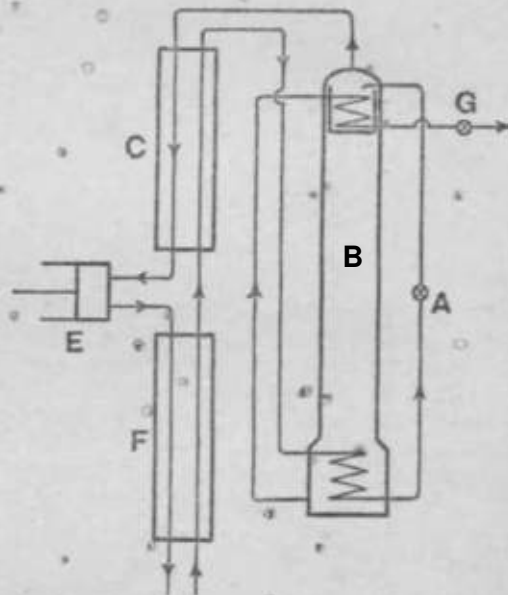

FIG. 8.

be produced. Linde plants can be made, without modification, to yield a part of the oxygen in the liquid form, by maintaining the air pressure suitably high.

Liquid Oxygen Plants.—Better yields of liquid oxygen can be obtained, however, by expansion with external work in an engine. An early type of plant developed by L'Air Liquido usefully combined the two methods of expansion. All the air was compressed to 200 atm., and nozzle-expanded at A (Fig. 8) to about 3 atm., into a simple rectification column B working at this pressure. The gases issuing from the column, still under this pressure, and after being heated by passage through interchanger C, are expanded in an engine E down to atmospheric pressure with production of external work, being capable then of pre-cooling the compressed air to about  $-50^{\circ}\text{C}$ . in interchanger C. Since the refrigerating effect, in the case of simple nozzle expansion, is nearly proportional to the difference of the pressures, expansion from 200 atm., to only



3 atm., will not result in any appreciable diminution in the cooling obtained; but, on the other hand, expansion in an engine\* of the low-pressure air at a relatively high temperature is very effective, providing a useful substitute for the Linde ammonia machine. Liquid oxygen collecting at the base of the column B is cooled by passage through a coil immersed in liquid air at the top of the column before withdrawal at O in order to diminish the loss by evaporation when the pressure is reduced.

In the effort to obtain greater yields of liquid oxygen, other types of plant were produced by L'Air Liquide, employing compound expansion engines. The air, at 40 or 60 atm., after partial expansion, was reheated by passage through an interchange in counter-current to unexpanded air, before a second expansion. About one half of the oxygen in the treated air could be obtained in the liquid form. Such plants were built with outputs up to 80 litres of liquid oxygen per hour.

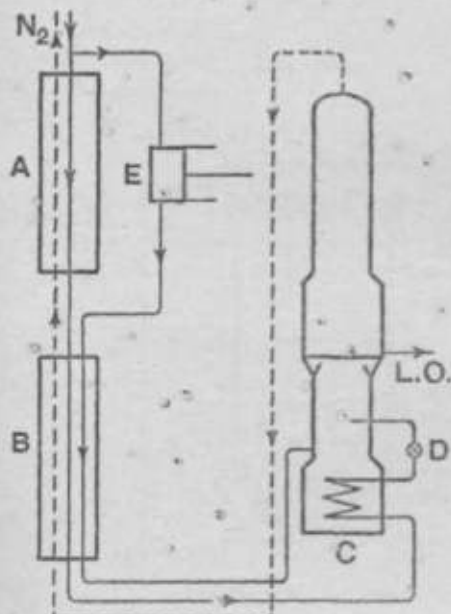

FIG. 9.

The extraction of substantially the whole of the oxygen in the treated air as liquid demanded the application of still higher pressures. Heylandt compresses the whole of the air to 200 atm. or more, and expands about 60% of it, in an engine (B, Fig. 9), without any pre-cooling, in one stage to about 5 atm., thereby lowering its temperature from about +15°C. to -140°C. The expansion engine is coupled up to the compressor shaft, and contributes some 9% of the energy required to operate the compressor. The expanded air, at about 5 atm., is further cooled in interchanger B by nitrogen leaving the upper column, and is then admitted to the base of the pressure column.

The remaining 40% of the compressed air at 200 atm. is cooled in interchangers A and B by heat exchange in counter-current with the outgoing nitrogen, containing only 2-3% of oxygen, is completely liquefied in a coil immersed in the liquid bath at the base of the

pressure column, and is then nozzle-expanded into the same column at D. Liquid oxygen is drawn off with a purity of about 99.7%, and in quantity may amount to 470 litres per hour. Plants of the largest capacity yield 1 litre of liquid oxygen for about 1 kw.-hr.

L'Air Liquide has contrived to extract in the liquid form substantially the whole of the oxygen in the treated air by a somewhat similar process. In this case the compressed air is supplied at 150 atm., and the greater portion of it (four-fifths) expanded in an engine E (Fig. 10) after being cooled to about -30°C. Suffering a pressure drop of 135 atm., it leaves the engine at about -135°C. at 4 atm. pressure, and passes directly to the pressure column A of the double-column rectification system. The remainder of the compressed air is further cooled and liquefied by the issuing nitrogen, to be then introduced at a suitable level B in the pressure column. The expansion engine is coupled to a compressor

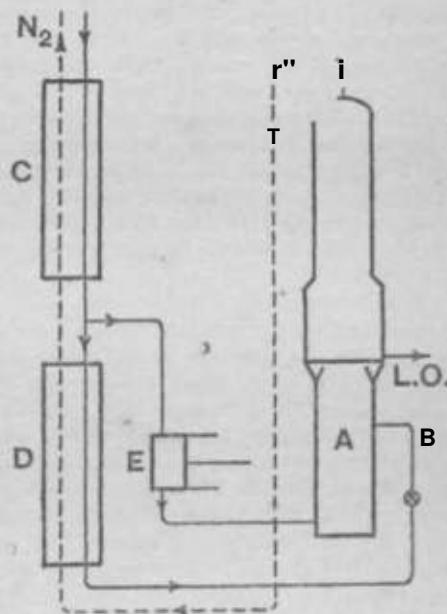

FIG. 10.

brake, a single stage machine operating in parallel with the third stage of the main compressor, and is thus made to contribute some 8% of the total energy required for air compression. Liquid oxygen is withdrawn at a minimum purity of 99.5%, and plants to yield 300 litres per hour have been constructed. Such plants likewise yield 1 litre of liquid oxygen for about 1 kw.-hr.

Oxygen Storage and Transportation.—Liquid oxygen plants were developed and perfected in the first instance to meet the demand created by the application of liquid oxygen to explosives. Much larger quantities of the liquid later became necessary as a consequence of the advent of a new method of transporting and storing oxygen. Hitherto this had been done mainly in the gaseous form in the well-known steel cylinder, only a very small amount being conveyed in the liquid form in metal vacuum vessels. The latter are spherical in shape, generally made of spun copper, with long,

narrow necks. The space between the walls is highly evacuated, preventing to a large extent access of heat to the liquid in the inner sphere by conduction and convection, whilst the walls of the space are highly polished to diminish ingress of heat by radiation. Gases slowly leaking through the metal walls are absorbed by charcoal placed in a receptacle in the vacuous space in contact with the inner sphere. Charcoal has the remarkable property, discovered by Dewar in 1904, of very effectively removing gases at low pressures when cooled to the temperature of liquid oxygen. Charging of the container with liquid, therefore, automatically brings this property into play, and ensures an excellent vacuum. A container with a capacity of 25 litres loses per day about 0% of its full charge.

Construction difficulties arise in the manufacture of containers on this principle to hold more than about 100 litres. However, the need for vacuum insulation disappears with large vessels. Generally speaking, the rate at which heat enters the vessel, and hence the mass of liquid evaporated per unit time, is proportional to the surface of the vessel, while the mass of liquid that the vessel will hold is proportional to the volume. Whereas the surface area is proportional to the square of the diameter, the volume is proportional to the cube of the diameter. Hence it follows that as the sphere increases in size, the fraction of the full charge of liquid oxygen evaporated in unit time becomes smaller.

Heat-insulating materials like slag wool or magnesium carbonate can, in the case of large vessels, replace the vacuum jacket and yield a container with a quite small evaporation loss. This can be further diminished by conducting the cold evaporated gas through a pipe coiled in the insulating material. Containers having a capacity up to 12,000 litres have been constructed, with hourly losses of liquid less than 0.1% of the full charge. Whereas the usual trade cylinder is some 10 times as heavy as the contained gaseous oxygen, the weight of a spherical container holding 3,000 litres of liquid oxygen is less than one-third of the weight of the contained oxygen.

Transport costs are considerably reduced therefore in the latter case; about 8 times as much oxygen can be sent as liquid as could be sent in cylinders on a lorry of the same capacity. This method of distribution was developed mainly by Heylandt.

Liquid oxygen from the production plant is passed directly into a storage tank, of capacity up to 12,000 litres\* (about 350,000 cu. ft. of gas at 15°C. and 760 mm.), and is transferred as required to a transport tank, of capacity up to 3,000 litres. For rapid evaporation at the place of consumption a warm evaporator or a liquid oxygen pump is employed.

The warm evaporator consists of a seamless steel high-pressure vessel, immersed in a water jacket, and provided with a separate thin-walled inner vessel of similar shape, but somewhat smaller, so that an annular space exists between the two vessels, with little or no metal contact between the two. A definite quantity of liquid oxygen is introduced into this inner vessel from

the transport tank, the amount of liquid lost by evaporation during this operation being small by reason of the small heat content of the light inner vessel. A plug is then inserted in the filling opening, and as heat passes from the water jacket across the metal walls and the gas space, so liquid oxygen is evaporated. The resulting gas gradually builds up pressure in the evaporator and connected storage vessels. As the pressure rises the influx of heat increases, due to increased convection effects in the gas space, and the evaporation is complete in one-half to two hours. In this period from 24 to 400 cu. m. of highly compressed gas are obtained, according to the size of the evaporator (Fig. 11).

In the method operated by L'Air Liquide, the liquid is delivered from the transport tank by means of a pump, working in the cold liquid in a small auxiliary tank, wherein a constant level is maintained, sufficiently high to immerse the pump. The liquid oxygen, delivered by the pump, is evaporated in a number of copper coils

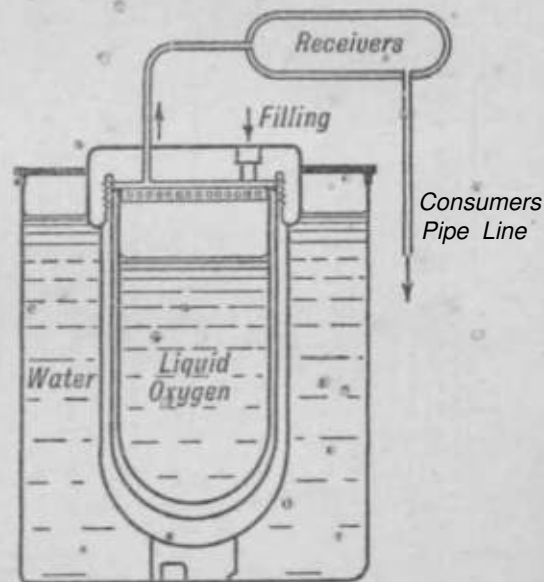

Fig. 11,

immersed in water, and thereafter delivered to the storage vessels. The pumps are built with outputs of 150 and 300 cu. m. of gas per hour.

For gradual evaporation, the liquid is stored in a cold evaporator (see this Vol., p. 181c), and evaporated according to requirements.

The Frankl Regenerator.—In recent years, developments of considerable importance have occurred in gaseous oxygen production, based on the introduction by Frankl of a more efficient heat interchange device. If the counter-current gases are at low pressure, it is possible to make a very efficient interchange of the usual tubular type only by increasing the copper transfer surface, or by increasing the gas velocity; the first expedient increases the difficulty of construction, whilst the latter increases the power expenditure, since greater velocity means greater power expenditure to overcome gas resistance. The Frankl interchanger, or "regenerator," as it is called, consists of a cylindrical vessel, 4-5 m. high, of suitable diameter, packed with layers of spirally

wound corrugated thin metal bands, about 2-ft cm. wide. A very large contact surface is thus provided in a relatively small space, with a considerably reduced resistance to the passage of gas. Such regenerators are easy to construct. They are installed in pairs. While one of the cold separated gases is being warmed by passage out through one of the regenerators, incoming warm air is being cooled by passage through the other; after a period of 1-4 minutes, the operation is reversed; the warm air is now sent through the regenerator which has just been cooled by separated gas, etc., the process thus being intermittent. In the case of air with two separated products, two pairs of regenerators would need to be installed. Water vapour and carbon dioxide are deposited from the air feed as solids on the regenerator packing, and are removed again as vapours by the outgoing gas, such removal being facilitated by the greater volume of the latter as compared with that of the incoming compressed air. Trace of water

vapour and carbon dioxide can be tolerated in practically all the applications of oxygen, and thus it becomes unnecessary to provide special air drying and purification equipment. Regenerators are especially applicable to the production of air enriched in oxygen; they are not applicable to plants for the production of very pure oxygen, since each change-over necessarily leads to a contamination of the oxygen by air. They are suitable only for large plants, and for oxygen qualities of 40-98.5%.

The increased efficiency of regenerators enables a plant to be run with an expansion engine fed with very low pressure air. With their aid it is possible to send part of the feed directly into the top column at the very low pressure obtaining there, and without any previous separation of its constituents. Hitherto, it was not possible to construct suitably efficient tubular interchangers for such low pressures. All the air is compressed to about 4 atm., and 30% of it is expanded in a turbine to the upper column

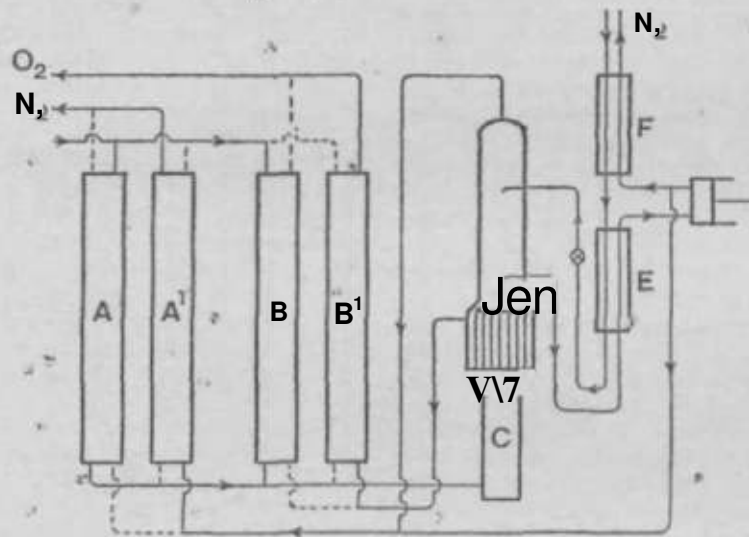

FIG. 12.

pressure, developing thereby sufficient cold for the process.

Several large plants have recently been built based on a variation of the last process. About 30% of the air feed is compressed to about 3 atm., cooled in regenerators A, B, or A', B' (Fig. 12), and admitted to the pressure column. To produce the necessary cold, nitrogen at 4-3 atm. is taken from the summit of the condenser, in quantity approximating to 20% of the total air feed, heated somewhat in interchanger E, and expanded in a high-speed turbine almost to atmospheric pressure. The greater part of the expanded nitrogen returns directly through the regenerators, a small amount passing through interchanger T. In interchanges E and F, the remaining 4% of the air feed, supplied at about 120 atm. The quality of the oxygen obtained is about 98.5%.

Again, if air enriched in oxygen (45%) is required, it becomes necessary to compress part of the air feed (about one-third) to only 1.5 atm. and expand it to 4 atm., since the lower pressure suffices to effect liquefaction after passage

through regenerators A, A' (Fig. 13), in a bath of impure oxygen having a lower temperature than pure liquid oxygen. The remainder of the air is merely boosted through regenerators B, B', and introduced directly into the single column D. In this case cold losses are made up by a separate supply of liquid air at E. Less power expenditure is needed to produce enriched air by this method, than by separating out substantially pure oxygen, and then mixing it with air.

Oxygen by Electrolysis.—Some of the oxygen used industrially arises as a by-product in the manufacture of hydrogen by electrolysis. The twentieth century has witnessed a great development in the use of hydrogen industrially for such purposes as ammonia synthesis, oil and fat hardening, liquefaction of solid fuels, etc. Where cheap water power has been available hydrogen produced electrolytically has been able to enter this field, stimulating efforts to build more perfect electrolyzers. The purity of electrolytic gases is exceptionally high. Modern plants yield hydrogen over 99.9% pure, and oxygen 99.8% pure, direct from the

electrolyser. Earlier plants were sometimes supplied with purifiers, wherein the gases were passed over platinised asbestos or palladium pumice at an elevated temperature. Moreover, the hydrogen is free from catalyst poisoning impurities like carbon monoxide, a feature of considerable importance in some applications. For this reason numerous small electrolytic plants have been installed where water power has not been available,

Generally, the oxygen from the larger plants is discharged to the atmosphere. In some cases it is used, e.g., for oxidising synthesised ammonia.

The lowest voltage at which a permanent current may be passed through water is in the neighbourhood of 1.7 v., and this determines the minimum possible energy expenditure. This efficiency cannot be attained in practice, however, as the resistance of the electrolyte and the resistance due to the presence of a diaphragm necessitate an increase in the voltage. The principle aims in the design of electrolytic cells have been to obtain the lowest possible resist-

ance, to prevent inter-mixing of the gases, to prevent corrosion of the component parts and to diminish the floor space occupied by the plant.

The resistance of the electrolyte has been reduced as much as possible by employing solutions having maximum conductivity. Sodium hydroxide (about 20%), potassium hydroxide (20-30%), and sulphuric acid have been used—the last no longer since corrosion difficulties have been too serious. Since the resistance of the electrolyte diminishes with rise in temperature, its temperature is maintained at from 40° to 50°C. The heat developed by the resistance of the electrolyte is sufficient for this purpose, if the current density is suitably high; indeed, with very high current-densities, the temperature of the electrolyte is prevented from rising above 80° by water cooling. The path of the current through the electrolyte from electrode to electrode is maintained as short as possible by arranging the electrode surfaces as close together as possible.

Inter-mixing of the gases is usually prevented by arranging a diaphragm of asbestos cloth,

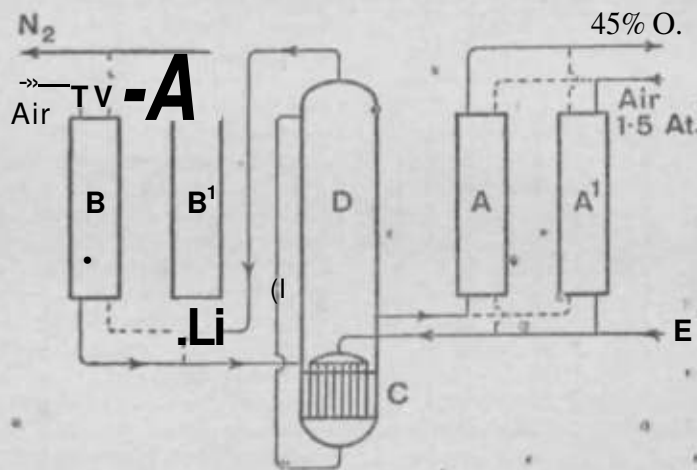

FIG. 13.

sheet iron, or nickel between the electrodes. Corrosion of the iron anode has been prevented by covering the surface with nickel, preferably in the matt condition. Floor space has been conserved by increasing current density per unit of electrode area, and by adopting the filter press construction.

The first practical applications of the electrolytic decomposition of water date back about 60 years. D'Arsonval produced oxygen for physiological purposes on a laboratory scale in 1885. The first large-scale apparatus was constructed, it seems, about 1886 by Latkinoff, who used iron electrodes in caustic soda solution with asbestos cloth diaphragms.

In 1892 Garuti produced a type of cell in which a number of flat sheet-iron electrodes were disposed vertically in a tank, alternately positive and negative, and close together. In place of asbestos, sheet-iron diaphragms were used, arranged as gas collecting bells over the cathodes; it was discovered that if the voltage between the electrodes was less than double the decomposition value for water, i.e., less than

about 3 v., the metal diaphragm would not act as an electrode. The diaphragm was later perforated below the electrolyte level, with the object of diminishing the resistance. Any number of diminishing cells could be placed in a tank, alternate anodes and cathodes being connected up in parallel.

In 1899 Schmidt introduced an essentially different construction. Iron plate electrodes, recessed on each side, were clamped together in this manner of a filter press, being separated from each other by an asbestos diaphragm and insulating joints. The electrodes were bipolar in this arrangement, current entering at one end of the press and passing from electrode to electrode throughout the length of the battery. Hydrogen was evolved on one face of each electrode, and oxygen on the other. The gases were led away through channels similar to those used in filter-press practice for the discharge of the filtrate. The number of cells per unit range from 30, requiring 70 v., to 130, requiring 300 V.

Schoop (1900) devised an electrolyser having electrodes surrounded by non-porous, non-

conducting diaphragms. A cylindrical cell contained two anodes and two cathodes, the electrodes consisting of metal tubes, each surrounded by a clay or glass tube. The gases were conducted may through the tubular electrodes. With aqueous sulphuric acid as electrolyte a lead tank and electrode were used; with alkaline electrolytes iron was the metal used.

Siemens-Schuckert developed a modification of the Garuti cell. Instead of one built up collecting bell, they made separate bells covering each electrode, "U" shape in plan, eliminating the danger of gas mixing through defects in the built up bell; and by shortening the electrodes, did away with the intervening diaphragms. The bells were kept apart by strips of insulating material. The leads were brought in to the electrodes through insulators in the top of the bells. Loss of heat by radiation was diminished by placing each tank in a box of sand.

<sup>1</sup> Modern Electrolyses.—Knowles improved on the Schuckert cell and the essential points of his design remain unchanged in his plants to-day. His first plant was installed at Bromborough, England, in 1912. It comprised 200 cells, each taking 3,000 amperes, and was for many years the world's largest installation. The largest of his many plants installed to date will, when completed, produce 5,000 cu.m. of hydrogen per hour, and, of course, half this amount of oxygen, with a power consumption of 24,000 kw.-hr. The upper part of each sheet-iron electrode is covered by a sheet-iron collecting bell, and the lower part of each alternate electrode is surrounded by an asbestos petticoat or diaphragm, open at its lower end. All the bells in one tank are connected rigidly together, and may be lifted from the tank complete with their connections. A skirting surround tag the entire block of bells forms a stand on which it may rest when removed from the tank.

In America a cell has been developed, with the object of retaining some of the great economy of floor space afforded by the filter press type. A battery of flat cells of the International Oxygen Company has the appearance of a filter press installation; but each cell is independent, and each has its own feed and discharge devices. Each cell consists of a thin rectangular frame of cast iron, to which two cast-iron plate electrodes are bolted, being separated into anode and cathode compartments by an asbestos diaphragm (36 in. by 43 in.). The inner surface of the electrodes have numerous projections to facilitate the circulation of electrolyte and the liberation of the gases.

The Levin cell is somewhat similar, but is divided into three compartments by two asbestos diaphragms, the central compartment containing the cathode and each outside compartment an anode.

In addition to the above, several other designs of the tank and bell type of electrolyser, with unipolar electrodes, have been constructed.

Up to 1925, all larger installations were fitted with the tank-and-bell type of electrolyser. After 1925, however, the filter press type came again into favour in the form of the Pechkranz electrolyser and was widely installed in large plants. The largest plant in the world, using

65,000 kw., in Norway (Norsk Hydro), was equipped with these electrolyses.

A unit consisted of 80-120 bipolar circular (originally rectangular) plate electrodes, nickel plated on the anode side, 1.8 metres in diameter, pressed together by strong bolts between two cast-iron end plates. The electrodes were separated by, and insulated from, a diaphragm consisting of a thin finely perforated nickel plate, having 1,200 holes per sq. cm.—the whole forming a self-contained battery. The electrolyte was a solution of potassium hydroxide working at a temperature of 65-80°C. The energy consumption of such a set was about 500 kw., the output about 90 cu.m. per hr. (at 20°C. and 760 mm.), i.e., about 5.5 kw.-hr. per cu.m.

Since 1929 a further improved filter-press electrolyser, the Bamag, has become increasingly adopted, in some instances replacing those of the Pechkranz type. Auxiliary electrodes are arranged, one on each side of each main electrode, the internal resistance of the cell being thereby reduced, so that the electrodes can carry a large specific current load without making the cell voltage uneconomical. One sq. m. of electrode surface can be loaded up to 2,500 amperes with the cell voltage not exceeding 2.2. Cells of other types cannot take more than 1,000 amperes per sq. m. for the same voltage. A woven asbestos cloth is used for the diaphragms. Some of the asbestos threads have a thin core of nickel steel, a feature which endows the cloth with great mechanical strength and long life. Bamag electrolyses are built for outputs ranging up to 500 cu.m. per hour from a single battery. A battery of 160 cells takes 7,500 amperes at a voltage of 350.

High-Pressure Electrolysis.—In 1928, Dr. Noeggerath made available information relating to the development of a cell in which high pressures were developed and maintained during normal operation—up to 200 atm. Advantages claimed were a diminution in gas storage space, elimination of compressors and cost of compression where the gases were to be used at high pressure, and a very efficient electrolysis from the point of view of power expenditure. It appears that a Noeggerath high-pressure cell has been working satisfactorily in Germany. In 1937 a pressure electrolyser was in operation near Gelsenkirchen, Germany, delivering hydrogen at 150 atm. It was on a semi-commercial scale, producing 400 cu. ft. of hydrogen per hour. An ingenious automatic control system was incorporated to guard against accidental mixture of the compressed hydrogen and oxygen. No appreciable economy in power consumption was indicated, and the ever-present risk of explosion is likely to militate against the adoption of the process.

C. R. H.

QXYHAEMOGLÖBIN (v. Vol. II, 216; VI, 164d, 165c, 166a, c).

"OXYLIQUIT" (v. Vol. IV, 546a).

OXYNARCOTINE (v. OPIUM, this Vol., p. 113).

OXYPHLOROGLUCINOL (v. PHENOL AND HOMOLOGUES, this Vol., p. 466d).

OZOKERITE. A natural mineral wax (v. Vol. II, 506d), colourless to white when pure, but



usually dark yellow or brown, often with a leek-green opalescence. It is probably derived from the polymerisation of paraffin-base petroleum, and is mined in Polish Galicia and formerly in Utah. In Galicia, ozokerite occurs squeezed up into fractures, so as to form vein-like bodies which are worked by shafts and galleries. It is used chiefly for the manufacture of wax candles and petrolatum, for electrical insulation, and for waterproofing. From a production of nearly 1,000 tons in 1930 the production of ozokerite in Poland declined to less than 400 tons, in 1935, when most of the output was sent to Germany for refining.

D. W.

OZONE,  $O_3$ . Molecular weight, 48.00

Historical.—In 1785, 11 years after the discovery of oxygen by Priestley, Van Marum drew attention to the fact that the air in the neighbourhood of an electrical machine possessed a characteristic odour. Cruickshank, in 1801, noticed the same characteristic odour in the gas appearing at the anode during the electrolysis of water. Schönbein, in 1840, was the first, however, to recognise the formation under these conditions of a new gas to which he gave the name "ozone" (from  $\sigma\zeta\alpha$ , I smell); he reported that ozone was formed during the electrolysis of water and also by the slow oxidation of phosphorus in the presence of moist air. At first this new gas was considered to be an oxide of hydrogen, but the researches of Marignac and De la Rive (1845), Becquerel (1852), Tait (1860), Soret (1866) and others led to the acceptance of ozone as an allotropic form of oxygen, formed by condensation of three molecules of oxygen to form two of ozone, thereby establishing the triatomic nature of the molecule.

Occurrence.—Ozone occurs in the atmosphere in varying proportions, being constantly produced in the upper regions of the atmosphere by the action of ultra-violet radiation on ordinary molecular oxygen. The reaction of ozone with water vapour to form hydrogen peroxide leads to a considerable diminution of the content of ozone in the atmosphere. Dobson, Harrison, and Lawrence found a marked connection between the amount of atmospheric ozone and the meteorological upper air conditions (Proc. Roy. Soc. 1927, A, 114, 521). It has been observed by Chalonge (Compt. rend. 1928, 186, 446) that the thickness of the atmospheric ozone layer is appreciably greater at night than in the day. The ozone content of city air is usually only a few parts per million. If present in amounts larger than about one part in twenty thousand ozone is an irritant. Edgar and Paneth have reported on the concentration of ozone in London air during a period of 6 months during 1938; considerable variation occurred (J.C.S. 1941, 511).

Preparation.—Ozone is most easily prepared by physical processes involving molecular oxygen. The formation takes place through the intermediate formation of atomic oxygen, which then reacts with a further molecule of oxygen by means of a three-body collision;  $O + O_2 + X = O_3 + X + 24.1$  kg.-cal. The third body (X) can be either another gas molecule or a catalytically active surface. From

this it would be expected that the yield of ozone should be dependent upon the gas pressure, and this is in fact the case. At atmospheric pressure oxygen atoms would make approximated a million three-body collisions per second, leading to the formation of ozone, whereas at 1 mm. pressure the frequency falls to 10 per second, and at even lower pressures the reaction  $O + O_2 + X = O_3 + X + 116.4$  kg.-cal. becomes predominant. Destruction of the atomic oxygen centres may also occur by the reaction  $O + O_3 = 2O_2$ , a process for which the activation energy has been calculated as 6.2 kg.-cal., compared with 4 kg.-cal. for the reaction  $O + O_2 = O_3$ . The overall reaction is a markedly endothermic process,  $3O_2 = 2O_3 - 69$  kg.-cal.

The endothermic character of the reaction suggests that the formation of ozone from molecular oxygen at high temperatures should be possible. Nernst has calculated that at 2,184°K. the equilibrium mixture with oxygen contains 0.1% at 3,230°K., 1%, and at 6,640°K., 10% of ozone. Experimental verification of these results has been obtained by Fischer and his co-workers (Ber. 1911, 44, 2956). In attempts to produce quantities of ozone by a purely thermal process a great deal of experimental work has been carried out. Small quantities of ozone are produced when air or oxygen is rapidly removed from contact with a Nernst filament or when a Nernst filament at 2,200°K. is plunged into liquid oxygen. Ozone has also been detected in the oxy-hydrogen and oxy-acetylene flames. The failure to produce ozone by thermal processes lies in the rate of decomposition of ozone at the elevated temperatures involved; thus, for example, at 1,000°K. in oxygen containing 1% of ozone the amount of ozone would be reduced to 0.001% in 0.0007 sec. (Clement, Ann. Physik, 1904, [iv], 14, 334).

The formation of ozone in an electrical discharge has been known since Van Marum's original discovery, and it is his method which most readily lends itself to the production of ozone, both in the laboratory and on the industrial scale. The simplest form of ozoniser makes use of the electrostatic field produced when a charge of high potential is allowed to pass through oxygen or air confined between the electrodes. This procedure was first used by Siemens in 1857, who subjected oxygen to both a silent and a glow discharge and showed that in both cases ozone was formed, although no ozone resulted from the action of electric sparks on oxygen.

The original Siemens "induction tube" consisted of two concentric glass tubes, the outer tube being covered and the inner tube lined with tinfoil. A current of air or oxygen was passed through the narrow annular space between the tubes, the metallic surfaces of the inner and outer tubes being connected with the terminals of an induction coil or electrical machine. Using such an arrangement, 3-8% of dry oxygen can be transformed into ozone. With improved ozonisers of this type working at atmospheric pressure and normal temperatures, yields up to 20% may be obtained.

A great number of modifications of the apparatus have been employed, all of which are

very similar in principle but vary in the nature and design of the electrodes. In the design due originally to Brodie (1872), and usually referred to as Berthelot's ozoniser, the metallic plates are replaced by electrolytic solutions (usually copper sulphate solution). Such an arrangement also provides some cooling for the ozoniser. Shot, powdered graphite, and similar materials have also been used as electrode materials.

The yield of ozone has been shown to be increased if pure dry oxygen is used in preference to air, which usually results in the formation of traces of nitrogen oxides. Further increase in the conversion may be achieved by cooling the ozoniser and incoming oxygen and also by increasing the pressure.

Briner and Durand (Compt. rend. 1907, 145, 1272) succeeded in converting 99% of the oxygen to ozone by cooling the ozoniser in liquid nitrogen. The conversion at  $-80^{\circ}\text{C}$ , using otherwise identical conditions, was only 11%.

The action of ultra-violet radiation on oxygen leads to the production of ozone. This photochemical formation can be shown to be a reaction involving atomic oxygen, but between 1,750 and 2,500 Å another reaction is also possible involving a chain process initiated by a collision between a photochemically activated oxygen molecule and a normal oxygen molecule,  $\text{O}_2^* + \text{O}_2 \rightarrow \text{O}_3 + \text{O}$ . The presence of excited mercury atoms has been shown to stimulate the formation of ozone (Dickinson and Sherrill, Proc. Nat. Acad. Sci. 1926, 12, 175). Jung and Kunau (Z. physikal. Chem. 1931, B, 15, 45) have shown that the photochemical formation of ozone in the presence of zinc oxide occurs only when the zinc oxide contains a little undecomposed zinc nitrate. No relationship was discovered between the sensitisation and the visible luminescence of zinc oxide.

Oxygen liberated at the anode during the electrolysis of aqueous solutions always contains a small quantity of ozone unless special precautions are taken to prevent its formation. High current densities and low electrolysis temperatures have been shown by Briner and Yalda (Chim. Acta, 1941, 24, 1328) to favour the formation of ozone. The concentration and nature of the electrolyte are less important contributory factors. Duhme and Gerdien (Wiss. Veröff. Siemens-Konzern, 1928, 7, 504) by use of a current density of 450 amp. per sq. cm., which they achieved by pumping cooled sulphuric acid at a high velocity through hollow electrodes, were able to obtain oxygen containing as much as 9% of ozone. Using an alternating current superimposed on a direct current, Archibald and Wartenberg (Z. Elektrochem. 1911, 17, 812) obtained yields of up to 37% of ozone. They attributed this remarkable increase in yield to the reduction of electrode polarisation.

The formation of ozone from oxygen under the influence of electrons and  $\alpha$ -particles has been reported. P. and M. Curie reported the formation of ozone by the action of radiation from radium (Compt. rend. 1899, 129, 823). It has been reported that the evaporation of salt water in the form of spray leads to the formation of traces of ozone; this may be associated with the

production of static electricity during the splashing of water.

Only a very few chemical processes lead to the formation of ozone in quantities other than traces. The majority of the reactions which liberate oxygen lead to the formation of traces of ozone.

The slow oxidation of phosphorus, which has been studied by many workers, also leads to the formation of some ozone, possibly by reaction between a peroxide and oxygen,

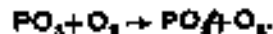

The reaction of fluorine with water leads directly to the liberation of ozonised oxygen containing up to 15% of ozone. The reaction, first studied by Moissan, is very vigorous, and may be represented by the following equations;



and



Small yields of ozone are obtained by the action of concentrated sulphuric acid on a powerful oxidising agent such as barium peroxide, potassium dichromate, or potassium permanganate. Ozone is not produced in the thermal decomposition of potassium chlorate, probably because of the high temperature required to effect the reaction, but in the presence of catalysts such that the reaction proceeds at a much lower temperature, traces of ozone appear. Various early reports of the formation of ozone in chemical reactions are in doubt owing to the difficulty of detecting traces of ozone in the presence of similar quantities of halogens and nitrogen oxides.

Pure ozone has been prepared by fractional distillation of ozone-oxygen mixtures (e.g., Karrer and Wulf, J. Amer. Chem. Soc. 1922, 44, 2391). Riesenfeld and Schwab (Ber. 1922, 55 [B], 2088) were able to obtain pure ozone by the following procedure: the liquefied gases were found after evaporation to separate into an upper, deep-blue layer, which was a solution of ozone in liquid oxygen, and a lower, violet layer, which was a solution of oxygen in liquid ozone and contained only 30% of oxygen at  $-183^{\circ}\text{C}$ . By separation of the lower layer and subsequent fractional distillation pure liquid ozone, which was dark blue, was obtained (b.p.  $-112.4^{\circ}\text{C}$ ).

The Industrial Preparation of Ozone.— Designs of industrial ozonisers are exceedingly numerous, although the principle underlying their design is in all cases that of the silent electric discharge.

The influence of the form of the ozoniser electrodes has been the subject of a paper by Otto and Bennett (J. Chem. Physics, 1940, 8, 899). Manley (Trans. Electrochem. Soc. 1943, 84, 147) has studied the electrical characteristics of the discharge occurring in ozonisers, whilst Lunt (Phil. Mag. 1927, [vii], 8, 1025) has reported on the power-voltage characteristics of the various types of Siemens ozonisers. The advantage of using a high frequency current in the production of ozone is discussed by Wilke (Siemens Z. 1927, 7, 11). A frequency of 10,000 cycles per sec. enables concentrations of 6-10 g.



of ozone per cu.m. to be reached, with a yield of 60 g. of ozone per kw.-hr.

A few examples of the various designs employed are cited below. The air in these ozonisers is drawn or forced through as is most convenient. When dry air is used and the temperature kept down, about 40-60 g. of ozone per kw.-hr. are obtained at a concentration of about 2 g. per cu.m. If oxygen is substituted, 120-180 g. of ozone are obtained. From thermochemical considerations the theoretical yield of ozone should be about 1.2 kg. of ozone per kw.-hr., so that the actual yield with air is only about 5%, and with oxygen 15% of theory.

**The Siemens-Halske Ozoniser.**—This ozoniser consists of a battery of glass or porcelain tubes with internal aluminium tubes, enclosed in an iron tank, containing water which is circulated to cool the equipment. The aluminium tubes are charged to a potential of 8,000-10,000 v. and the air passes through the annular space between the tubes. Each battery of six to eight tubes requires 0.5 kw.

**The Tindal Ozoniser.**—The use of a dielectric is avoided in this ozoniser by arranging for the air to pass at high velocity (this is necessary to prevent sparking) through an electric field maintained between an outer electrode, which is water cooled, and an inner electrode consisting of a metal plate.

**The Abraham-Marmier Ozoniser.**—This apparatus is based on the discharge of from 12,000 to 15,000 v. between two large glass plates adjacent to two water-cooled tanks which form the electrodes. The air passes solely between the glass plates.

**The Marius-Otto Ozoniser.**—A voltage of 11,000-15,000 v. is maintained between a fixed iron cylinder and a series of aluminium discs attached to a rotating axle; the air is passed directly through the tube, no dielectric being used.

**The Ozonair Ozoniser.**—Two plates (made of an aluminium alloy gauze) are separated by a plate of insulator. The open character of the plates ensures that the air circulation prevents undue heating and obviates the need for cooling. Several of these pairs of plates are enclosed in a case to form a unit. The voltage used is 5,000-8,000 v.

The following reviews deal with the design of ozonisers: Lewis, Chem. Eng. Mining Rev. 1923, 16, 105; Hartman, J.S.C.I. 1923, 42, 117T; Vivian, Compressed Air Mag. 19\*1, 46, 6568.

Technical ozone production is also dealt with in various textbooks of electrochemistry, e.g., K. Arndt in "Technische Electro-Chemie," Stuttgart, 1929.

**Physical Properties.**—Determinations of the molecular weight of ozone show that it is a triatomic molecule consisting solely of oxygen atoms. The structure of the ozone molecule was originally assumed to be cyclic in order to satisfy the known trivalency of oxygen. This formulation, however, failed to represent the reactions of ozone which suggested that it was "oxidised oxygen" and contained bonds of different strength; the formulation involving quadrivalent oxygen,  $O=O=O$ , was therefore often

preferred. Pauling (J. Amer. Chem. Soc. 1932, 54, 3581) has circulated the heat of formation from molecular oxygen of the cyclic structure. The value is much greater than is in fact, and this structure is therefore excluded. The quadrivalent oxygen atom is well known in molecules such as basic beryllium acetate, and possesses a tetrahedral valency distribution. By analogy with the carbon-dioxide molecule the molecule  $O=O=O$  would be expected to be linear. Evidence obtained from dipole-moment data suggested that the molecule was non-linear. Determination of the  $O-O-O$  valency angle and the O-O distance gave values of  $127 \pm 3^\circ$  and  $1.26 \pm 0.02$  A. The O-O distance is considerably shorter than the O-O distance in hydrogen peroxide (1.46 A.), where the value is assumed to be that of a single O-O bond. Since neither the cyclic nor the linear structure is satisfactory in the light of new evidence, Shand and Spurr (ibid. 1943, 65, 179) have described the molecule in terms of resonance between the following structures:

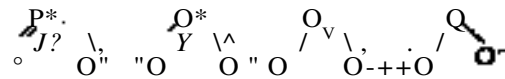

Ozone has been variously described as possessing an odour like sulphur dioxide, garlic, and chlorine. The odour of ozone is perceptible at concentrations of less than one part per million of air. In concentrations greater than two parts per million ozone irritates the respiratory tract and at high concentrations it results in damage to the tissues.

Many of the early determinations of the physical properties of ozone were carried out using impure samples; however, Riesenfeld and his school, and Karrer and Wulf, were able to obtain pure ozone, and re-determined many of the physical properties.

Pure gaseous ozone possesses a faint blue colour and has a vapour density exactly corresponding to the formula  $O_3$ . By extrapolation of values obtained with mixtures of oxygen and ozone the ratio of the specific heats has been obtained,  $\gamma = 1.29$ . Ozone is more soluble in water than is oxygen. Ladenburg (Annalen, 1898, 31, 3508) and Moufang (Wochschr. Brauerei, 1911, 28, 434) have obtained the following values for the solubility in water:

0°	7°	25°
20	10	1.5 mg. per l.

The solution possesses the characteristic odour of ozone and has strong oxidising properties. Several determinations of the partition of ozone between water and ozonised oxygen have been made; values from 0° to 60°c. were determined by Mailfert (Compt. rend. 1894, 119, 951), who showed that the solubility decreased with increasing temperature, becoming zero at 60°c.

The solubility of ozone decreases slightly with increasing acid concentration. Thus the absorption coefficient at 0°c. for 0.1 N. sulphuric acid is 0.487 (Luther, Z. Elektrochem. 1911, 11, 682), compared with a value for water at 0°c. of 0.494. Solutions of ozone in water decompose at an increasing rate with decrease in the acidity.

concentration or on addition of alkalis. The solution of ozone in 0.1 N. sulphuric acid has been shown to obey Henry's Law. Chlorine dioxide dissolves nearly five times as much ozone as does water (Briner and Perrottet, *Helv. Chim. Acta.* 1939, 22, 585).

The values of the electrode potential of ozone, which have recently been reviewed by Briner (*ibid.* 1942, 25, 98), vary widely, but all are below the value of 0.84 v. at 20°C. calculated from the free energy of the equation  $O_3 = fO_2$ . The discrepancies are due chiefly to decomposition of ozone at the electrodes. Kassel (J. *Ghem. Physics*, 1933, 1, 414) obtained the value 2.07 v. for the oxidation potential of the system  $O_3(g) + 2H^+ + 2e \rightarrow O_2(g) + H_2O(l)$ .

The data available on the magnetic properties of ozone are exceedingly discordant. Becquerel (Compt. rend. 1881, 92, 348) and Schumeister (Sitzungsber. Akad. Wiss. Wien, 1881, 89, 45) state that the gas is more paramagnetic than oxygen—whereas Wulf (Proc. Nat. Acad. Sci. 1927, 13, 744) has found that ozone is less paramagnetic than oxygen, with a susceptibility which is approximately zero or possibly negative. These observations of Wulf are in agreement with G. N. Lewis's theory, since ozone contains no unpaired electrons. Vaidyanathan (Indian J. Physics 1928, 3, 151) has calculated from the additive values of the magnetic properties of ozonides, which are all very strongly diamagnetic, that ozone is diamagnetic ( $-2.5 \times 10^{-6}$ ). Laine (Compt. rend. 1933, 196, 910) has, however, shown that ozone is paramagnetic with a susceptibility independent of temperature. The whole question of the magnetic properties of ozone is in a very unsatisfactory state, the results obtained so far indicating that the susceptibility has a small value either positive or negative.

The refractive index of ozone has been calculated by extrapolation from values obtained with oxygen-ozone mixtures by Cuthbertson (Phil. Trans. 1914, A, 213, 16):

$$\mu - 1 = 4800 \mu_1 - 5085 \mu_2 + 5209 \mu_3 - 5461 \mu_4 + 5770 \mu_5 - 5790 \mu_6$$

( $\mu$  is the wave-length in Angstrom units and  $\mu_n$  is the refractive index).

Gaseous ozone has absorption bands in the infra-red between 4.8 and 15  $\mu$ , in the visible spectrum between 4,350 and 6,400 A. (Colange, *Radium*, 1927, [vi], 8, 254) in the near ultra-violet between 3,050 and 3,500 A., known as the Huggins bands (Barbier and Chalonge, *Ann. Physik*, 1942, [v], 17\* 272) and in the far ultra-violet continuous absorption occurs with a maximum reported at 2,500 A. (Läuchli, *Helv. Phys. Acta*, 1928, 1, 232; *Z. Physik*, 1929, 53, 92).

The Raman spectrum of ozone was examined by Sutherland and Gerhard (*Nature*, 1932, 130, 241) using a 30% solution of ozone in liquid oxygen; an extremely weak doublet corresponding to a mean frequency shift of 1,280 cm.<sup>-1</sup> was observed.

Ozone is absorbed on silica gel and the isotherms have been calculated (Magnus and Urechling, *Z. physikal. Chem.* 1929, A, 145, 27).

The dipole moment of ozone, according to

Lewis and Smyth (*J. Amer. Chem. Soc.* 1939, 61, 3063), is  $1.049 \times 10^{-18}$  e.s.u.

Liquid ozone has a deep blue colour and boils at  $-112.4^\circ\text{C}$ . At  $-183^\circ\text{C}$ . the liquid density is  $1.71 \pm 0.05$ . The critical temperature is  $-5^\circ\text{C}$ . and the corresponding critical pressure is 65 atm. and density 0.54. The liquid solidifies at  $-251.4^\circ\text{C}$ . to deep indigo crystals. The vapour pressure of liquid ozone follows the equation:

$$\log p = (3.100/4.571) + \frac{10}{L-75} \log T - (0.05099/4-571)T + 5-850,$$

where  $p$  is the pressure in mm. of mercury and  $T$  is in degrees absolute (Spangenberg, *Z. Physik. Ghem.* 1926, 119, 419). Liquid ozone is miscible in all proportions with liquid nitrogen. It is a non-conductor of electricity. Chemical Properties.—The chemical properties are all associated with the instability of the ozone molecule, and apart from the formation of certain additive compounds are characteristic of a powerful oxidising agent. Several substances which do not react with oxygen do so readily with its allotrope, ozone.

Pure dry gaseous ozone decomposes slowly at room temperature but at  $300^\circ\text{C}$ . the decomposition is almost instantaneous. The decomposition of oxygen-ozone mixtures occurs with luminescence at elevated temperatures. The decomposition  $2O_3 = 3O_2 + 69 \text{ kg.-cal.}$  is an exothermic reaction also involving an increase in volume and can become explosive if the rate is sufficiently high. Pure liquid ozone is said to be quite stable, but admixed with liquid oxygen it is dangerous, being sensitive to mechanical shock.

Exposure to light accelerates the decomposition of ozone and accordingly it is more reactive as an oxidising agent in the presence of sunlight. Platinum black, copper oxide, lead dioxide, manganese dioxide, and various other oxides exert a catalytic effect on the decomposition. Traces of chlorine and nitrogen dioxide accelerate the decomposition, which can also occur catalytically on metallic surfaces, as has been shown by Kashtanov, Ivanova, and Ryzhov (*J. Applied Chem. U.S.S.R.* 1936, 9, 2176). Silver is the best catalyst and aluminium the least effective; copper, lead, and tin have little effect. Phosphorus pentoxide was reported to catalyse the decomposition, but Smith (*J. Amer. Chem. Soc.* 1925, 47, 1850) has shown that this action was due to impurities, and that resublimed phosphorus pentoxide does not effect the decomposition.

Barbier and Chalonge have shown that when ozone and nitrogen are passed together through a hot tube, nitrogen dioxide is formed (Compt. rend. 1941, 213, 1010). The decomposition of ozone in aqueous solutions is dependent on the pH of the solution. If neutral salts have no effect; acid salts decrease the rate, and alkaline salts increase the rate. The decomposition is apparently of the second order,

Ozone reacts with most metals under appropriate conditions, though gold and members of the platinum group are not attacked, and the reaction leads to the formation of oxides. In the case of silver a higher oxide appears to be formed (Jirsa and Jelinek, *Z. anorg. Chem.* 1926,

158, 61). If the metals are in the massive state a surface film only is formed. Dry ozone is reported to be less reactive towards metals than is moist. A ferrochrome alloy containing 25% chromium is resistant to ozone. Mercury is attacked by ozone with the formation of mercurous oxide, which is soluble in the surface of the mercury, causing the metal to lose its meniscus and to adhere to glass. The mercury is restored on treatment with water (Hodgson, J.C.S. 1924, 125, 462).

Carbon in the form of charcoal absorbs 65% of ozone (by weight) at temperatures from  $-30^{\circ}$  to  $+20^{\circ}$  C, with the formation of an acidic substance. Above  $20^{\circ}$  C. carbon dioxide and monoxide are the only products (Bruns, K<sup>z</sup>lova, and Maksimova, J. Phys. Chem. U.S.S.R. 1935, C, <sup>^</sup>^ Sulphur, phosphorus, and arsenic are converted by moist ozone into sulphuric, phosphoric, and arsenic acids, respectively. Antimony is not readily attacked at room temperature.

Fluorine does not react with ozone, whereas the other halogens react readily, chlorine giving chlorine trioxide,  $\text{ClO}_3$ , and chlorine heptoxide,  $\text{Cl}_2\text{O}_7$  (Byrns and Rollefson, J. Amer. Chem. Soc. 1934, 56, 2245); bromine at lower temperatures gives the oxide  $\text{Br}_2\text{O}_8$ , and iodine gives a mixture of  $\text{I}_8\text{O}_3$  and  $\text{I}_4\text{O}_9$ . Combined hydrogen is frequently oxidised to water, as for example in palladium hydride and in hydrogen sulphide. Except in the case of hydrogen fluoride, ozone reacts readily with the hydrogen halides with the formation of water and the free element. Ammonia and phosphine react with ozone to give water and an acidic substance. The reaction between ammonia and ozone at  $-74^{\circ}$  is accompanied by the formation of an orange-red coloration which rapidly fades as the temperature increases and disappears at  $-60^{\circ}$  C, the final reaction products being ammonium nitrate and nitrite.

Carbon monoxide is slowly oxidised by ozone at ordinary temperatures, the reaction being catalysed by light and moisture. Moist sulphur and nitrogen dioxides are rapidly oxidised to the corresponding acids. The reaction with sulphur dioxide below  $40^{\circ}$  C. is of interest since all the oxygen available in the ozone is utilised ( $3\text{SO}_2 + \text{O}_3 \rightarrow 3\text{SO}_3$ ). However, in the case of nitrogen dioxide at  $25^{\circ}$  C. the reaction gives  $\text{N}_2\text{O}_6$  and  $\text{O}_2$ .

Briner and Lachmann (Helv. Chim. Acta, 1943, 26, 346) have studied the oxidation of sulphur dioxide by ozonised oxygen on silica gel catalysts at  $200^{\circ}$  C., and have shown that the ozone acts as a catalyst, greatly increasing the yields of sulphur trioxide. Lowry and Lemon (Nature, 1935, 135, 433) report that when a mixture of nitrogen pentoxide and ozone is passed along a hot tube, a reaction appears to occur and a blue zone is formed. They attribute this to the formation of a higher oxide,  $\text{NO}_3$ .

The reaction between ozone and potassium iodide was one of the first used for its identification and estimation. The first stage in the oxidation results in the formation of free iodine and oxygen, but further oxidation leads to the formation of iodate and periodate. Quantitatively the action of ozone on acidified potassium

iodide solution gives very variable results, the oxidation being a combination of two mechanisms\*,  $2\text{HI} + \text{O}_3 \rightarrow \text{I}_2 + \text{H}_2\text{O} + \text{O}_2$ , and

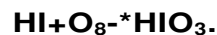

The reaction is best carried out in a buffered solution. Potassium bromide with ozone yields free bromine, the oxidation to bromate being considerably slower than that of iodide to iodate! Cremer and Duncan (J.C.S. 1933, 181) have shown that ozone reacts with solid  $\text{KIBr}_2$  with the formation of potassium iodate and free bromine.

Nitrites are oxidised to nitrates with the liberation of oxygen, whilst metallic sulphides with ozone give the corresponding sulphates. Alkali thiosulphates yield chiefly sulphate and dithionate, although some sulphur is deposited. Solutions of lead and manganese salts give the corresponding dioxide, ferrocyanides are converted to ferricyanide, and solutions of salts in the lower valency state (e.g.,  $\text{Fe}^{II}$ ,  $\text{Sn}^{II}$ ) give precipitates of the corresponding hydroxide in the higher valency state.

The oxides and hydroxides of metals are generally converted to the highest valency state by the action of ozone; thus hydrated ferric oxide in the presence of alkali gives rise to ferrates. Ozone will oxidise platinum held in a coordination complex from the divalent to the quadrivalent state if the solution is acid. With an alkaline solution the products are very complex (Chugaev and Klopchin, Z. anorg. Chem. 1926, 151, 253).

The action of ozone on sodium azide was investigated by Gleu and Roell (*ibid.* 1929, 179, 233). It is supposed that pernitrous acid,  $\text{HOO-NO}$ , is formed, ftoyes, Hoard, and Pitzer (J. Amer. Chem. Soc. 1935, 57, 1221) have claimed that ozone at  $0^{\circ}$  and  $24^{\circ}$  C. slowly oxidises silver nitrate (argentous) in dilute nitric acid solution to a black soluble argentic nitrate.

Crushed potassium hydroxide absorbs ozone with the formation of a brown substance of uncertain composition, frit related to the oxide  $\text{K}_2\text{O}_4$ , which was regarded on the older views as a salt of the hypothetical ozonio acid,  $\text{H}_2\text{O}_4$ . The reaction of ozone with hydrogen peroxide results in the mutual reduction of the reactants to give water and oxygen.

Ozone can add on to organic compounds containing unsaturated linkages (e.g., benzene) to form ozonides (*q.v.*). Other reactions with organic molecules are those of oxidation. Thus formaldehyde may be formed by passage of a mixture of methane and ozone through heated tubes (Wheeler and Blair, J.S.C.I. 1922, 41, 331). Briner and Carceller (Helv. Chim. Acta, 1935, 18, 973) have shown that ozone acts as a catalyst in the reaction between hydrocarbons, such as butane and propane, with oxygen at temperatures above  $180^{\circ}$  C.

The oxidation of organic compounds has found application in organic synthesis. Thus, for example, reactions such as the oxidation of borneol to camphor (Briner, Egger, and Paillard, *ibid.* 1924, 7, 1018) and of thioethers to sulphones (Böhme and Fischer, Ber. 1942, 75 [J3], 1310) occur readily and in very good yield by use of ozonised oxygen\*

Chemiluminescence has been observed during the reaction between ozone and certain dyestuffs such as alizarin, eosin, Methylene Blue, Rose Bengal, etc. (Biswas and Dhar, Z. anorg. Chem. 1930) 183, 154). Ozone attacks rubber and many greases rapidly.

Use.—Ozone, on account of its strong oxidising properties, has found extensive use as a bactericidal agent, oxygen being among the resultant products. Its use in the sterilisation of water is free from the disadvantages which are associated with agents such as chlorine. The utilisation of ozone for the sterilisation of air in confined spaces has been made use of in the London underground railway system. For the sterilisation to be successful and non-irritant the air must be moist. Care has to be taken in its use in view of the toxic nature of higher concentrations. Elford and Ende (J. Hygiene, 1942, 42, 240), investigating the use of ozone as an aerial disinfectant, have shown that its effectiveness is dependent on the relative humidity. In concentrations which can be breathed safely for long periods ozone is not an effective germicide.

As a neutral, harmless bleaching agent it has found use in the food and fine fabric industries for the bleaching of oils, fats, and waxes, and of ivory, flour, and starch.

Mixtures of liquid oxygen and ozone and hydrocarbons on absorbent materials have been suggested as explosives. The drying of paints is hastened by treatment with ozonised oxygen.

Detection and Determination.—One part of ozone in five hundred thousand parts of air is detectable by odour. Ozone may be detected easily by its action on manganese chloride paper, which turns brown owing to the formation of higher oxides of manganese. Potassium iodide and starch papers turn blue, but the test is also positive for chlorine. However, by the incorporation of phenolphthalein in the paper instead of starch the chlorine may be readily differentiated, since ozone reacts with the formation of potassium hydroxide. Ozone does not affect solutions of potassium permanganate, and may thus be differentiated from nitrogen dioxide and hydrogen peroxide. Test papers soaked in solutions of the following reagents give specific reactions (Arnold and Mentzel, Ber. 1902, 35, 1327, 2902; Keiser and McMaster, J. Amer. Chem. Soc. 1908, 39, 96):

	O <sub>3</sub>	NO <sub>2</sub>	H <sub>2</sub> O <sub>2</sub>
Tetramethyl-pp'-diamino-diphenylmethane	Violet	Straw	None
Benzidine	Brown	Blue	None

The determination of ozone is most easily carried out by shaking with a neutral solution of potassium iodide and subsequent titration of the liberated iodine with sodium thiosulphate:  $O_3 + 2KI + H_2O = O_2 + 2KOH + I_2$ , 1 ml. of 0.1 N. potassium iodide is equivalent to 24 ing. of ozone. Juliard and Silberschatz (Bull. Soc. chim. Belg. 1928, 37, 205) recommend keeping the solution at pH 7 by use of a borax or phosphate buffer.

Usher and Rao (J.C.S. 1917, 111, 799) recommend the use of the reaction between ozone and nitrites in neutral or acid solution for the deter-

mination of ozone in the air, the change in nitrite concentration being determined by a colorimetric method.

Tetramethyl-pp'-diaminodiphenylmethane may be used for the direct colorimetric estimation of ozone, and the use of test papers soaked in this reagent provides a convenient method of detection.

Briner and Perrottet (Helv. Chim. Acta, 1937, 20, 293) have determined ozone in concentrations of  $10^{-8}$  to  $10^{-6}$  by passing the gas into a solution of benzaldehyde in carbon tetrachloride and estimating the benzoic acid formed.

Schlezing (Acta Physiochim. U.R.S.S. 1935, 3, 435) passed the gas through an alcoholic solution of dihydroacridine. The fluorescence of the acridine formed by oxidation is measured photometrically. A similar method for the leuco-base of fluorescein has been developed by Egorov (Analyst, 1929, 54, 189).

Edgar and Paneth (J.C.S. 1941, 511) have examined critically the methods available for the determination of ozone in the atmosphere and have used both a spectrographic method and a method based on the tetramethyl-pp'-diaminodiphenylmethane reaction for the determination of ozone in the atmosphere. Nitrogen dioxide was removed before this estimation.

Ozone may also be determined by means of sodium arsenite:

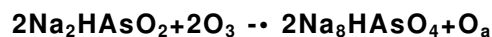

and also by means of alkali bisulphite solution. By passage of the gases through potassium permanganate or chromic acid solution, hydrogen peroxide is removed and the ozone passes on unreacted. This is generally a necessary precursor of any determination.

D. S. P.

OZONIDES. (i) Inorganic Ozonides.—The so-called inorganic "ozonides" or "ozonates" are obtained as unstable yellow, orange, or red substances by the action of ozone on the hydroxides of the alkali metals. These substances, to which, e.g., the structure  $(KOH)_2O_3$  is ascribed, decompose on keeping with the formation of caustic alkali, oxygen, and alkali tetroxides; acidification gives hydrogen peroxide and oxygen (Traube, Ber. 1912, 46, 2201; 1916, 49, 1670; see also Streeke and Thienemann, *ibid.* 1920, 53 [B], 2096).

(ii) Organic Ozonides.—The rate of addition of ozone to an olefin is decreased when the double bond is conjugated with carbonyl groups or when three or more phenyl groups, or two chlorine atoms, are attached to the doubly-bound carbon atoms; conjugated bonds add 1 mol. of ozone rapidly and further ozone only slowly; butadiene gives a very unstable ozonide without evidence of 1:4 addition. *Trans*-isomers in general add ozone more rapidly than the *cis*-forms. Ozonolysis in the vapour state may give a higher ozonide than is found in solution, e.g., dipentene diozonide (Noller *et al.*, J. Amer. Chem. Soc. 1936, 58, 24; and Spencer *et al.*, J. Org. Chem. 1940, 5, 610). Excessive ozonolysis must always be avoided and when complete absorption of ozone does not occur the control of reaction is difficult; the use of bromine as an indication of the presence of un-

ozonised double bonds is not wholly satisfactory since substitutive reaction readily occurs. In the ozonolysis of rubber, substitution by bromine increases as ozonolysis proceeds, giving a substantially constant total bromine uptake. On completion of the ozonolysis a per-compound is formed which inhibits bromine substitution so that the bromine uptake suddenly falls to zero (Pummerer, Rubber Chem. Tech. 1937, 10, 114). Control of ozone concentration (*e.g.*, by passage through aqueous sodium hydroxide) is highly desirable, a high concentration being required for aromatic and conjugated compounds, but a low concentration (1-5%) is essential for certain readily oxidisable aldehydes. Protection of a sensitive aldehyde has also been obtained by ozonising in formic acid. Borland and Hibbert, *Canad. J. Res.* 1940, 18 [B], 30.

Low temperature and dilute solutions are generally preferable for efficient ozonolysis; various solvents are suitable, *e.g.*, methanol, chloroform, acetic acid, hexane or even water (Briner, *Helv. Chim. Acta*, 1937, 20, 1211; 1930, 21, 1297); dry ethyl acetate is particularly suitable if the ozonide is to be submitted to catalytic hydrogenation.

**Decomposition of Ozonides.**—For gentle decomposition Strauss (*Annalen*, 1912, 393, 235) recommends in the first place drawing a stream of moist air through the solution of the ozonide, water being added later. Hydrolytic methods of decomposition have to some extent been replaced by reductive methods, especially where aldehydes and ketones rather than acids are required as final products; such methods must be applied immediately after ozonolysis. Among effective reducing agents are zinc dust with acetic acid or with silver nitrate and hydroquinone, aluminium amalgam, potassium ferrocyanide, sulphur dioxide, and sodium bisulphite (Whitmore, *J. Amer. Chem. Soc.* 1932, 54, 3710; 1934, 56, 176). Catalytic hydrogenation (Fischer, *Annalen*, 1928, 464, 82; *Ber.* 1932, 65 [B], 1468) has also found widespread use and with suitable precautions high yields of aldehydes and ketones have been obtained; acid rearrangement

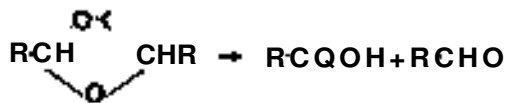

which is the major cause of low yields may be avoided by preventing temperature rise during hydrogenation. Raney nickel (excess) has also been used without additional hydrogen being required (Cook and Whitmore, *J. Amer. Chem. Soc.* 1941, 63, 3540).

Oxidative decomposition (alkaline permanganate or alkaline hydrogen peroxide) favours formation of acids.

**Structure of Ozonides.**—Glycol formation on reduction of ozonides, which would be expected from Harries' formula

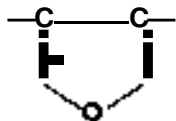

has not been observed; instead, ketonic products are obtained. According to Staudinger (*Be\** 1925, 58 [B], 1088), the first stage in the formation of an ozonide is a simple attachment of ozone to the double bond to give a molozone,

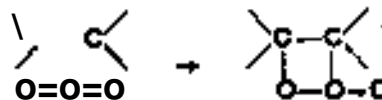

which may subsequently behave in a variety of ways:

1. It may undergo intermolecular rearrangement to a stable tetro-ozonide, resembling an acetal, which structure is now assigned to all of the normal ozonides, *e.g.*,

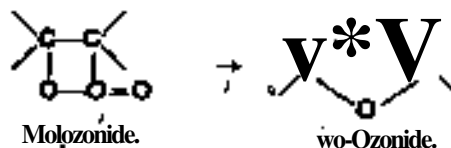

2. The molozone may polymerise, and this tendency is favoured by solvents which induce association and by the occurrence of the bond in a ring structure so that isomerisation is hampered.

3. Thermal decomposition of a molozone may give a ketone and a ketone peroxide or an acid,

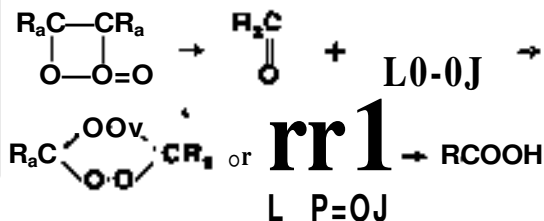

It is doubtful whether molozones, which would be reducible to glycols, ever have a separate existence (Pummerer, *Rubber Chem. Tech.* 1938, 11, 7; *see also* Rieche, Meister, Sauthoff, and Pfeiffer, *Annalen*, 1942, 553, 187), and it is now considered more probable that the first product of attack of ozone is the diradical (C) which immediately transforms via the tetro-ozonide or to a polymeric ozonide,

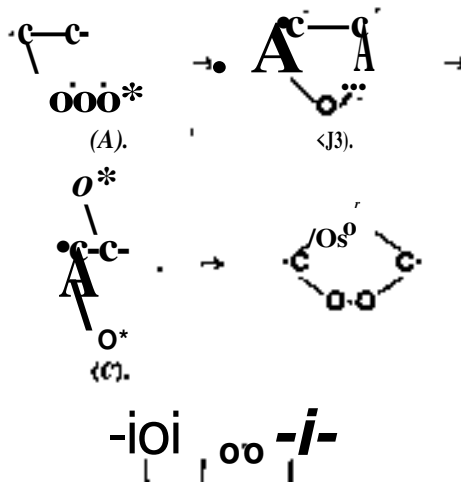

the formation of new —O—C— and —O—O—C— linkages being accompanied by weakening and ultimately by breaking of the —C—C— bond (F&Gnsr, Trans. Instt Rubber Ind. 1945, 21, 122ff)

The ozonides are analogous to dialkyl- and dihydroxy-dialkyl peroxides,

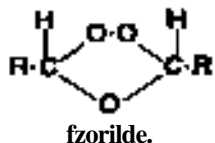
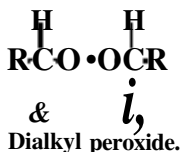
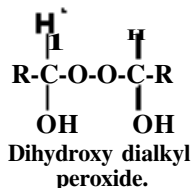

and the molecular refraction, parafactors, and ultra-violet absorption of ozonides and peroxides indicate the presence of a simile\* group in both types of compound. Raman spectra, dielectric constants, and absorption spectra of ozonides have also been studied by Briner (Helv. Chim. Acta, 1936 *et seq.*), and by Beresowskaja and Kifrnossowa (J. Phys. Ghemf RUBS. 1935, 6, 125) whose work suggests the possibility of a co-ordinately bound oxygen atom which determines the peroxidic properties. Treatment of allylbenzene ozonide with sodium

malonic ester has established the presence of the ethereal oxygen linkage.

By dehydration of dihydroxy-dimethyl peroxide Rieche and Meister (Ber. 1932, 65 [B]. 1274) have obtained an oil identical with w-butylene ozonide,

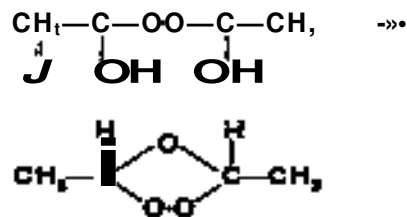

Rieche, Meister, Sauthoff, and Pfeiffer (i.e.) have also shown that the bimolecular peroxide formed in the fission of oleic acid ozonide with iron or acetic acid is identical with the peroxide

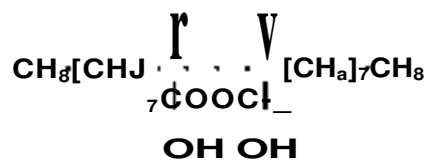

whence the first stage in the fission is formulated as a hydrolysis of the ether linkage of the ozonide. *Hydrolytic Decomposition of Ozonides.*—The following mode of hydrolytic decomposition is suggested by Rieche:

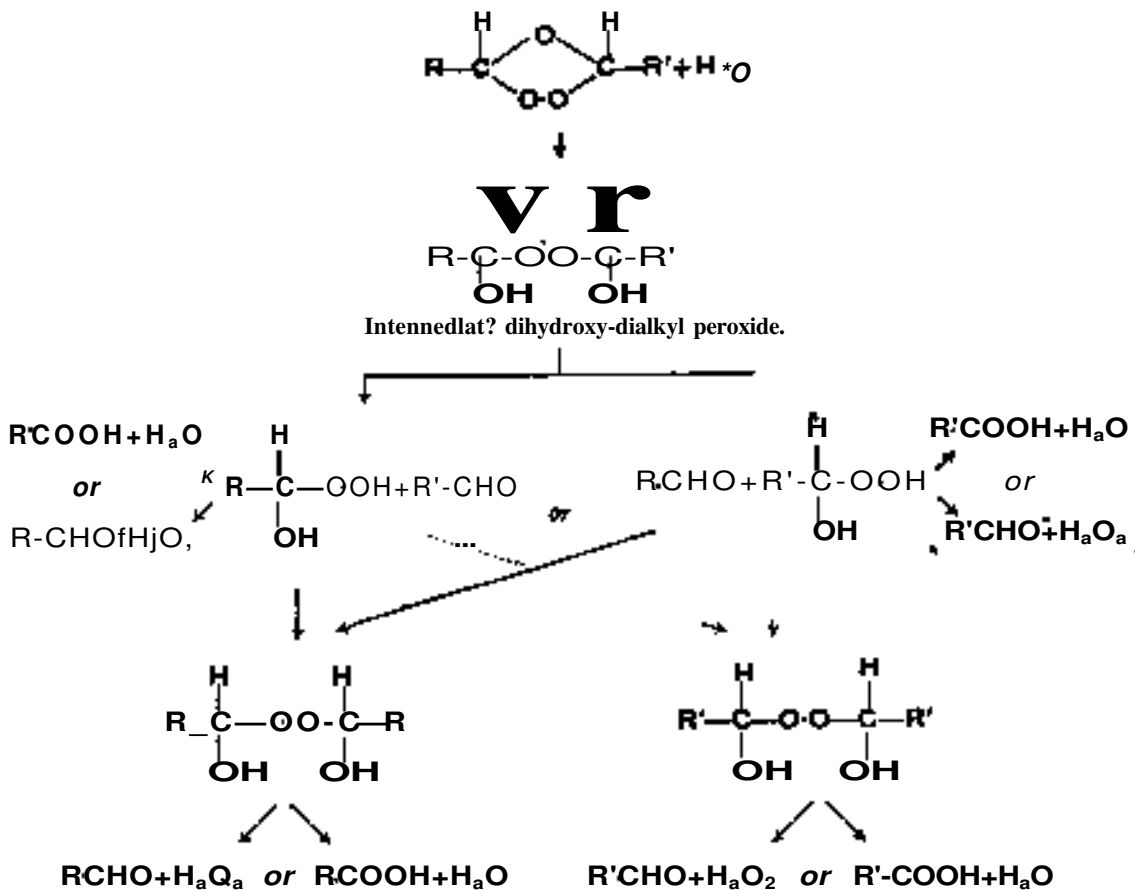

but since dimeric diaryl ketone peroxides have been obtained by the ozonolysis of arylated olefins without the introduction of water at any stage of the reaction Marvel and Nichols (J. Org. Chem. 1941,6,296) have suggested that ozonides may cleave spontaneously to give the usually-found products of ozonolysis.

**Ozonolysis of Triple Bonds.**—Ozonolysis of acetylenes yields ozonides in which the carbon to carbon linkages still remain:

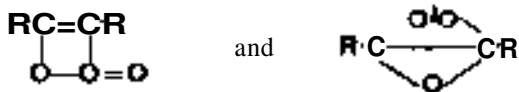

are probable structures (Hurd and Christ, *ibid.* 1936, 1, 141). Hydrolytic decomposition yields l:Z-aiKc^:ies (Jacobs, J. Amer. Chem. Soc. 1936, 58, 2272); acids are formed subsequently:

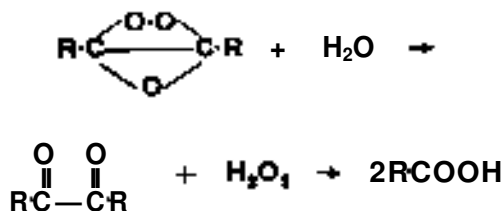

#### Monomeric Ozonides.

The large number of normal ozonides now known cover every class of organic compound; they are well catalogued in a publication by C. D. Harries, "Untersuchungen über das Ozon," Berlin, 1916. Among some interesting ozonides described more recently are the following:

Unstable ozonides of *maleic* and *fumaric acids* are formed at low temperature although the corresponding esters form ozonides normally; an explosive ozonide of *maleic anhydride* has been isolated (Briner, *Helv. Chim. Acta*, 1937, 20, 1211; 1938, 21, 1297). In the ozonolysis of *triolein* ozone adds primarily at the double bonds but further ozonolysis converts the ester group to a perester (Nasini and Mattei, *Gazzetta*, 1941, 71, 302, 422). Ozonides of hydroaromatic and higher aliphatic olefins are characterised by a high degree of stability, but aromatic ozonides are generally highly explosive; the decomposition products of aromatic ozonides indicate contributions to the aromatic structure by both Kekulé forms.

**cyclofentene Ozonide, C<sub>4</sub>H<sub>8</sub>O<sub>3</sub>**, is obtained by ozonisation in hexane cooled in a freezing mixture, when the insoluble ozonide is precipitated. Distillation gives a viscous yellow liquid, b.p. 60-62°/10 mm. Water yields glutaric acid and aldehyde and the half-ajplehyde of glutaric acid.

**Ozonides of terpenes, e.g., limonene ozonide**, obtained as a white solid by ozonising limonene in carbon tetrachloride, is freed from accompanying oxozonide by solution in acetic acid. Treatment with water first decomposes the aliphatic ozonide grouping, and the ketonic ozonide so produced may be separated by ether extraction. Prolonged treatment with water decomposes the second ozonide grouping:

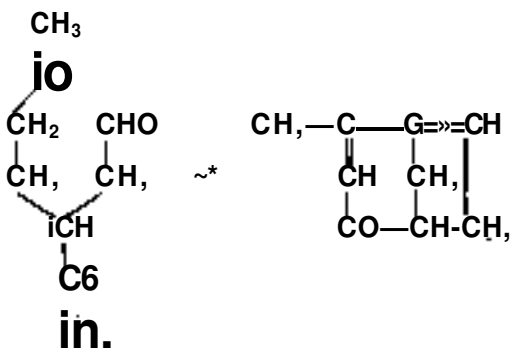
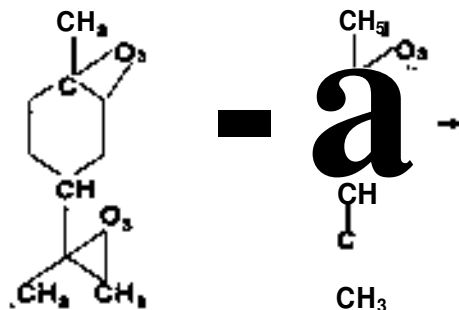

*a*-Fenchene Ozonide gives on Hydrolysis an acid

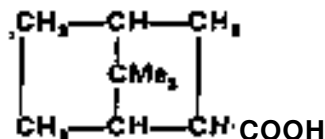

which represents the only known case of non-fission of a double bond by Ozonolysis.

#### Dimeric Ozonides.

These cannot be distinguished by analysis nor by mode of decomposition from normal ozonides but molecular weight determination shows them to be bimolecular.

**Di - sym. - butylene Ozonide.** — Bimolecular material (C<sub>4</sub>H<sub>8</sub>O<sub>3</sub>)<sub>2</sub> constitutes the larger part of crude *ayra*-butylene ozonide, obtained by ozonising *sym.*-butylene in methyl chloride (Harries and Evers, *Annafon*, 1912, 390, 238). The dimer is extremely viscous, is readily soluble in alcohol, moderately soluble in benzene, and sparingly soluble in light petroleum. It is surprisingly stable, and can be heated in solution without decomposition; strong heating causes explosion at 125°. Warm 4% alkali hydrolyses it to acetic acid.

«The structure

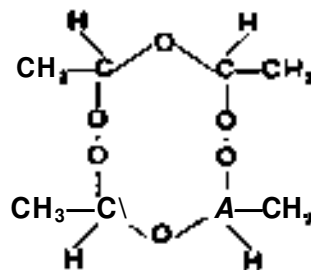

is assigned to it (Rieche).



*Polymeric Ozonides.*

Normal ozonides are frequently accompanied by viscous oils, the amount of which is increased by prolonging ozonolysis. The polymeric ozonides are high-boiling, very viscous oils with a weak but penetrating odour, and are more stable than normal ozonides. Rieche has suggested an open-chain structure for the polymers

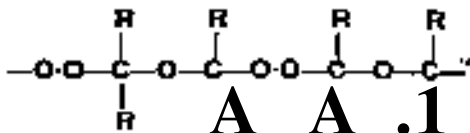

Polymeric *cyclohexene* ozonide is obtained as a white solid when 9% ozone is led into a 5% solution of *cyclohexene* in hexane. It melts at 60-65°, exploding at 140-150°. Two polymeric

*cyclopentene* ozonides are known, one explosive and one not explosive; styrene ozonide is also polymeric.

*Oxozonides.*

A pure ozonide RO<sub>3</sub> is not converted to an oxozonide RO<sub>4</sub> on treatment with unwashed ozone, so that pure oxozonides can only be obtained when their rate of formation is much greater than that of the ozonide. Di-*sym.-butylene oxozonide* is obtained from di-*sym.-butylene* with unwashed ozone. Treatment for a short time with water yields di-*sym.-butylene ozonide*.

*Literature.*—C. D. Harries, "Untersuchungen über das Ozon, 1903-1916," Berlin, 1916; A. Rieche and F. Hitz, "Alkylperoxide und Ozonide," Steinkopff, Dresden, 1931; A. Rieche, "Alkylperoxide und Ozonide" (a review), *Angew. Chem.* 1932, 45, 441; L. Long, *Chem. Reviews*, 1940, 27, 437.

G. F. B.

## P

P-VITAMIN. The vitamin nature of dietary factors affecting capillary resistance or capillary permeability in man remains doubtful; however, numerous observations, mainly in animals, and some clinical reports warrant, even at this stage, a brief survey of the field.

*History.*

In 1936 Szent-Györgyi *et al.* (*Deut. ingd. Woch.* 1936, 62, 1325; *Nature*, 1936; 138, 27, 798, 1057) reported that extracts from paprika and lemon juice contained a substance or substances other than ascorbic acid (Vitamin-C) which exerted a beneficial effect on hemorrhagic disorders, due to increased capillary permeability, and decreased the number of hemorrhages in scorbutic guinea-pigs, prolonging the survival time of the animals. They called the active principle "Vitamin-P" (P for permeability) and the extracted substances from lemons "citriji." They established that "citriji" consisted chiefly of an isomeric mixture of two flavanone glycosides, hesperidin and eriodictin, related to the group of yellow plant pigments.

Other observers (Zilva, *Biochem. J.* 1937, 31, 9-5, 1488; Moll, *Klin. Woch.* 1937, 16, 1653; and others) and later Szent-Györgyi himself (*Z. physiol. Chem.* 1938, 255, 126) were unable to confirm the earlier findings in animal experiments. However, these negative results were again reversed, first by Zacho (*Acta path. microbiol. Scand.* 1939, 16, 144) and then by Rusznyak and Benkő (*Science*, 1941, 94, 25; *Klin. Woch.* 1941, 20, 1265), who included also rats in their tests, Bacharach *et al.* (*Analyst*, 1942, 67, 313; *Biochem. J.* 1942, 36, 407) and by Bourne (*Nature*, 1943, 152, 659).

*Animal Experiments.*

All these authors agree that guinea-pigs, on a scorbutogenic diet augmented with ascorbic acid, develop an increased capillary fragility, this becomes apparent only when negative pressure (expressed in millimetres of mercury) or

suction is applied by means of a glass cup to the skin of the animals, and petechiae or haematoma are produced by less suction or lower negative pressure than that required to cause hemorrhages in the normally fed animal. Whereas some investigators such as Bourne (*I.e.*), and Rusznyak and Benkő (*I.e.*), administered test substances to animals with a maximum deficiency (or a minimum of capillary resistance) and observed activity by a return to normal, others such as Bacharach *et al.* (*Ix.*) treated the guinea-pigs during the period of deficient diet with various doses of the material being tested and compared the capillary resistance of these animals with a control group. Thus "citriji," hesperidin, and even the corresponding aglycones, such as hesperetin or eriodictiol, were found active. Majorvki *et al.* (*J. Pharm. Exp. Ther.* 1944, 80, 1) reported that mice exposed to sudden low-pressure suffered from hemorrhage in the lungs; if given extracts from citrus fruits they were to a certain extent protected against these injuries; these results were not confirmed by others (Kibrick and Goldfarb, *ibid.* 1944, 82, 211). But such discrepancies of observation in this field are not rare, as even with the guinea-pig the same experimenter may suddenly encounter failure of methods which before gave regular results. Though Bacharach and Coates tentatively proposed a provisional unit (P.U.) (*J.S.C.I.* 1943, 62, 85) and expressed the contents of fruits and vegetables in such "Vitamin-P" units, there exist serious doubts whether any of the methods at present available, even if qualitatively valid, are reliable from a quantitative point of view.

*Chemistry.*

The "citriji" of the Hungarian workers consists mainly of two flavanone glycosides, hesperidin (=hesperitin rutinoside; I, R=rutinose=J-rhamnosido-d-glucoside, R'=CH<sub>3</sub>) and eriodictin (=eriodictiol i-rhamnoside; I, R=rhamnose, R'=H), cf. Mager (*Z. physiol. Chem.* 1942, 274, 109).

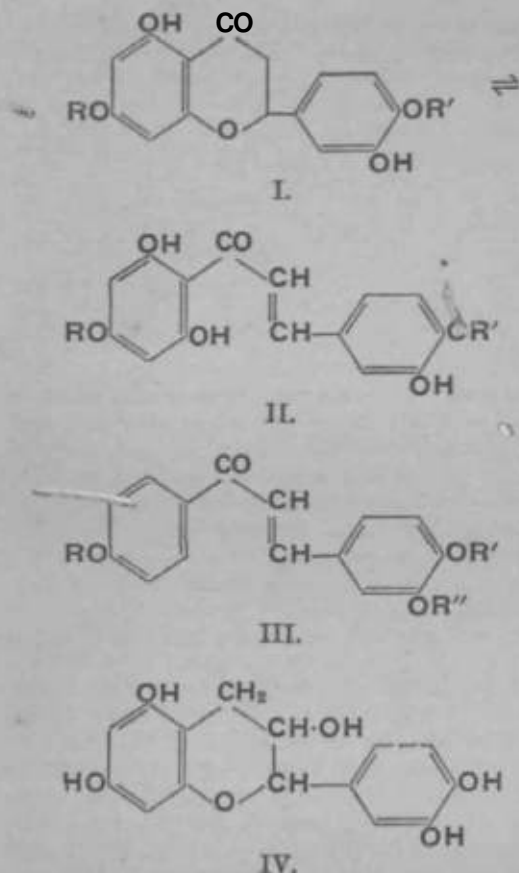

Wawra and Webb (Science, 1942, 96, 302) isolated a "hesperidin" from lemon peel and showed it to be a protein complex of the isomeric hesperidin chalkone (II, R=sugar, R'=CH<sub>3</sub>). Later Higby (J. Amer. Pharm. Assoc. 1943, 32, 74) demonstrated that pure hesperidin and related compounds had little effect on capillary resistance in contrast to hesperidin chalkone, either isolated from oranges or of a synthetic origin. When methylated, this chalkone "was stabilised and retained its activity. These chalkones possess a deeper coloration and a greater solubility in water. An ethereal extract of Bpray-dried blackcurrant juice, prepared by Pollard (Nature, 1942, 150, 490; Ann. Rep. Agric. and Hort. Res. Sta. Long Ashton, 1943, 141), had according to Bachar&ch *et cd.* (I.e.) greater activity thnn liespcridio derivatives; its chemical nature has not been established. Bourne (private communication) found that chalkones of type HI, lacking hydroxyl groups in the 2' and b" positions still possessed activity in the guinea-pig. Lavollay *et al.* (Compt. rend. 1942, 215, 49tf; Compt. rend. Soc. Biol. 1944, 138, 179) added catAhin and d-epicatcchin (IV) to the series of capillary active substances, claiming the latter to be the most active compound for increasing capillary resistance in guinea-pigs.

#### Experimental Work m Man.

Reports on treatment of increased capillary agility in man, in many cases detected by application of negative or positive pressure on the skin, with davanoue derivatives and other "P" active substances are numerous but not conclusive. Among others, Scarborough (Edinb.

Med. J. 1944,51,381, etc.) claimed that "citric" and hesperidin incased low capillary resistance whereas other authors failed to achieve the same success. A survey on the latest clinical observations can be found in F. Bicknell and J. Prescott, "The Vitamins in Medicine," Hermann, London, 1946, p. 863 ff.

Other surveys on the general subject of "Vitamin-P" are: Lindheimer, Hinman, and Haliiday (J. Amer. Diet. Assoc. 1942, 18, 503); H. R. Rosenberg, "Chemistry and Physiology of Vitamins," Interscience Publ. Inc., New York, 1942, p. 513 ff; Javillier and Lavollay, Helv. Chim. Acta, 1946, 29, 1283; Borell, Jubilee Volume, Basle, 1946, p. 216; Parrot and Cotereau, Arch. int. Physiol. 1946, 54, 197; Cotereau *et al.*, Nature, 1946, 158, 343; Griffiths *et al.*, Proc. Soc. Exp. Biol. Med. 1944, 5 & > 228; Madison and Pohle, J. Lab. clin. Med. 1947, 32, 340.

#### PAINT QILS (u. Vol. IV, 81c).

PAINTS. Although the time is long past when paint could be regarded simply as a mixture of dry powders ground in linseed oil, yet "paint," the term being regarded in the broadest sense, may still be defined as "a suspension of finely ground solids in a medium consisting of non-volatile and volatile ingredients." The dry powders are generally known as *pigments* and *extender's*. The former retain their colour when dispersed in the paint film, whereas extenders usually contribute only to the general properties of the product and are transparent or translucent in the medium. The *medium* consists either of drying oils, with or without the addition of natural or synthetic resins in solution in suitable solvents, or may be composed wholly of a solution of synthetic resin. If drying oils are present and the paint is required to dry at room temperature there will usually be an addition of driers, i.e., metallic naphthenate, linoleates, or resinates which catalyse the oxidation.

Having defined the fundamental constituent, each group will be considered in greater detail before a general description is given of the very large variety of materials which may now come within the scope of the paint manufacturer.

**Pigments.**—It is the pigment which confers on a paint its colour and opacity. A full description of the manufacture and properties of pigments is given in the article under the appropriate heading. It may not be out of place, however, to mention that in selecting a pigment for any particular product it is not enough merely to consider the colour, even though that is regarded as of primary importance. The retention of initial colour is of equal significance, and particular care needs to be taken when choosing pigments for paints that have to resist specially adverse conditions, e.g. of excessive humidity or chemically polluted atmospheres. The range of available pigments is extremely wide and it must be the paint formulator's aim to keep abreast of developments in the allied industries. All pigments impart colour to the medium in which they are suspended. There are, however, very wide differences in the capacity or "covering power"

which is conferred even by different members of the same class; for example, it is well known that titanium dioxide has greater hiding power than zinc oxide or antimony oxide. Some dyestuffs yellows and reds, and particularly maroons, are notoriously transparent. In all cases the manufacturer has to compromise on opacity, for both economic and practical considerations limit the amount of pigments that may be added to any medium. The economics merely concern the price a customer is willing to pay to secure the properties he requires, but the practical aspect depends usually on the "oil absorption" of the pigment in question. This is a property of the pigment capable of experimental determination. It defines the minimum amount of raw linseed oil necessary to produce a homogeneous paste and hence is related to the amount of non-volatile medium needed to produce a finish of the required gloss. It is obvious that there must be an upper limit to the amount of pigment which can be incorporated if a high-gloss product is to result.

Extenders do not usually confer colour on the medium in which they are dispersed and rarely have any effect *per se* on the opacity, although they may improve this latter property by promoting increase of the film thickness on application. Among the more commonly used are barium sulphate (barytes and blanc fixe), calcium carbonate (Paris white)\* powdered asbestos, ground silica of various grades, china clay, and various diatomaceous earths. Calcium sulphate (terra alba), barium carbonate (withelite), and powdered slate also find special applications\*.

Extenders are included in paint compositions for a variety of reasons. In the cheap type of oil paint they may be added merely to increase the "body" of the paint and to permit the use of a lower amount of pure pigment. They are used infrequently in high-grade gloss finishes and then only when a small quantity of high-opacity pigments is the principal ingredient. In such paints as printers, fillers, and undercoats, however, they fulfil an important function in controlling the degree of gloss obtained and imparting the desired properties such as ease of brushing or of rubbing down (flatting). The uses to which extenders are put are generally related to the oil absorption. Those having the higher oil-requirement are often used to prevent excessive settling of the pigment portion of the paint. It is not absolutely true to say that extenders are always transparent or translucent in a medium. They may be so in one binder but be opaque in another. This is particularly the case with the waterpaints (*q.v.*) where Paris white is quite commonly used as a white pigment. The opacity of any pigment or extender is related to its own refractive index and to that of the medium in which it is dispersed. The greater the difference, the more opaque will the pigment appear.

Medium.—It is in the medium (otherwise known as the vehicle), which was once so simple, that the greatest progress has been made in modern technology. The extent and diversity of types are now very great. Two broad subdivisions at once appear, *i.e.* (a) paints which

"dry" without application of heat (air drying materials), and (b) those products which require the use of elevated temperatures either for ordinary drying or for the completion of a chemical change of the resin to secure full development of resistant properties. The drying of some paints of the former class may be accelerated by the application of heat but in general it is preferable to have specially formulated materials in each class.

A further pair of broad groups may be discovered, the first no means synonymous with the first two. It is the division into paints which dry by *evaporation of solvent only* (frequently termed "lacquers," although this name is also given to many products falling in the second class), and paints which dry by oxidation or other chemical change of the medium, *e.g.*, the formation of linolein by oxidation of linseed oil or the polymerisation of "urea-formaldehyde" resins on stoving. It is perhaps easiest to discuss the various types of media in terms of this second grouping.

The components which are used as straight solutions, and dry by evaporation only, include shellac, Manila copal, and similar alcohol-soluble natural resins, salts and esters of rosin, nitrocellulose in most of its applications, and very many of the modern resins such as those derived from chlorination of natural rubber and polymerisation of vinyl acetate and vinyl chloride, styrene, etc. In the other group, *i.e.*, those drying by chemical change (whether at room temperature or on stoving), are linseed oil and all the modifications produced from it by heat treatment (stand oil, lithographic varnishes, and blown oils, etc.); varnishes prepared from linseed oil and other drying oils such as china-wood oil, perilla oil, or dehydrated castor oil by heating with natural or synthetic resins; all alkyd resins, *i.e.*, resins prepared from polyhydric alcohol and phthalic anhydride in the presence of drying oils; phenol-formaldehyde, urea-formaldehyde, and melamine-formaldehyde resins, and so on. The oil-length of the varnish is expressed as the ratio of the oil to resin, *e.g.*, 2:1, or as a percentage of the whole resin complex. Varnishes with less than 60% of oil are often termed "short oil" and those over 60% or 1:1 are termed "long oil." The air-drying types within this group will usually contain metallic driers in the form of liaphthenates, linoleates, or rosinates of lead, manganese, or cobalt. Recent work has also added knowledge on the use of iron, cerium, and zinc salts, but in spite of a considerable amount of work the complicated processes which occur during the oxidation of drying-oil films are still incompletely understood (*cf.* Morrell and Davis, *Trans. Faraday Soc.* 1936, 32, 209; Morrell and Phillips, *Paint Technology*, 1942, 7, 130, 169, 181; *see also* DRYING OILS, Vol. IV, 81c). The other members of the group complete the chemical changes associated with polymerisation either on application of heat or of specific catalysts. The details of many types are given in the articles on PLASTICS.

As in the case of pigments, the selection of the medium most appropriate for any particular paint is not a matter to be undertaken lightly.

Due regard must be paid to the known performance data of the various types and also to this suitability for use with the particular pigment composition which the formulator has in mind. Linseed-oil paints, for example, are very easy to apply, but give rather soft films with not very high gloss and somewhat limited durability. Most pigments in common use can be dispersed in linseed oil without risk. As the art progressed, it was found that the gloss of linseed oil paints could be increased by heat treatment of the oil or by cooking in resin. This also tended to harden the film, but at the same time increased the viscosity of the non-volatile medium so that additional thinner was required to enable the paint to be brushed. Moreover, if the added resin, or the product of heat treatment, were acidic pigments each as zinc oxide had to be avoided. The alkyd resins have been found to possess excellent general durability and to be reasonably tolerant of most pigments. Air-drying, oil-modified phenol-formaldehyde resins have also found considerable application in the decorative and protective fields, although a tendency to yellow on ageing is a marked disadvantage. In the industrial field, nitrocellulose lacquers still command a very wide range of uses, but the statutory regulations attending the use of these low-flash materials are aiding the introduction of stoving materials of the plastic urea-formaldehyde type. Castor-oil alkyds are among the most widely used plasticisers and give very satisfactory results at stoving schedules of 1 hour at 250V. upwards. There is not space in this article to expand the formulating practice with the various types of media, and reference must be made to standard works or to the manufacturer's publications.

- Thinners.—Many of the resins mentioned above are solids or very viscous liquids and before these can be pigmented or used as paints they must be reduced in viscosity or brought into solution. For this purpose it is usual to employ organic liquid, either alcohols, esters, or hydrocarbon. Ketones are also used to a less extent. Thus, shellac is usually dissolved in methylated spirits; linseed oil paints are thinned either with turpentine or "white spirit" (a petroleum fraction boiling from about 160 to 190°) while some of the more highly polymerised resin varnishes, particularly alkyds, require a large proportion of aromatic hydrocarbon in the thinner. Nitrocellulose and related cellulose esters require mixtures of esters or ketone with alcohols and aromatic and aliphatic hydrocarbons, and the balancing of the various constituents of the solvent mixture has considerable influence on the final properties of the lacquer produced.

#### METHODS OF DISPERSION.

For all paint purposes it is necessary that pigments should be in a finely divided state and this is usually arranged by the colour manufacturer. However, it is still necessary when making the paint to disperse the pigment in the medium and to ensure that the particles of pigment are thoroughly wetted. To achieve this end, there is a number of types of mill in common use in the paint trade, in most of these the

principle applied is that of shearing a viscous solution, although the actual viscosity of the mill base varies from type to type. The simplest means of dispersing is the rubbing of the pigment into the medium on a ground glass or marble slab by means of a palette knife or muller. The first graduation from this process is the hand or power driven "cone" mill in which the mixed ingredients of the paint are fed by gravity between one fixed and one rotating closely fitting surface, the lower one equipped with suitable means for removing the paint. "Roller" mills have been, and still are, very largely used for making all qualities of paint, although the exposure of materials on the open rolls makes them unsuited for use with volatile solvents. The triple-roll machine (Fig. 1) will serve to illustrate the principle. The three rolls, made of either steel or granite and of the same diameter, are revolved in the direction indicated in the diagram, D is a flexible steel scraper to remove the finished product. The three rolls are geared to revolve at different speeds, c being the fastest; in some models the middle roller (B) has a lateral motion also. The rollers are capable of being adjusted for proximity. The materials are mixed into a coarse paste either by a "pug" machine or by

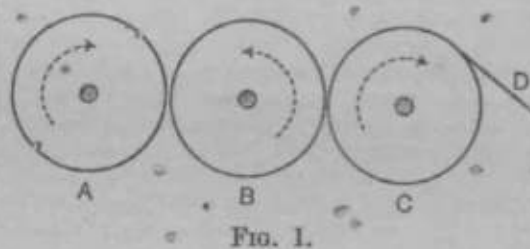

band, and this is fed to the machine between the rollers A and B. The setting of these rollers will determine how much passes on to the underside of B and is transferred to c, while the pressure between a and c will determine the extent of the final grinding. One pass is normally sufficient for the usual ready-mixed paints while two or three passes are needed for the finer qualities of product. Two-roll and single-roll-and-brill mills are adaptations of the same principle and are used more particularly for refining of semi-dispersed products.

The next important type is the "ball mill," which consists of a steel cylinder mounted horizontally on its axis equipped with a suitable door for loading and for drawing off the finished product. The mill may be fitted with a jacket through which cold water can be circulated for cooling purposes, and may also be lined with stoneware blocks, particularly if it is desired that the product shall not be contaminated with steel flakes. The mill is charged to half its volume (or more according to the ideas of the user) with steel or porcelain balls the diameter of which may range from 1/2 to 1 1/2 in. The mill is charged with the vehicle, pigment, and extra thinners, and run for the time necessary to secure proper dispersion; the paint is then decanted. The advantages of this mill are that the whole operation is conducted under mixed conditions and there is no loss of volatile solvents.

In preparing pastes, either in oil or of the diaphanous type, the so-called "edge-runner" or "pan" mill (Fig. 2) is of great value. The diagram shows the general method of operation. This dispersion is carried out by a heavy steel wheel revolving in a steel pan. The scrapers A, B, & C direct the paste from the wheel and the

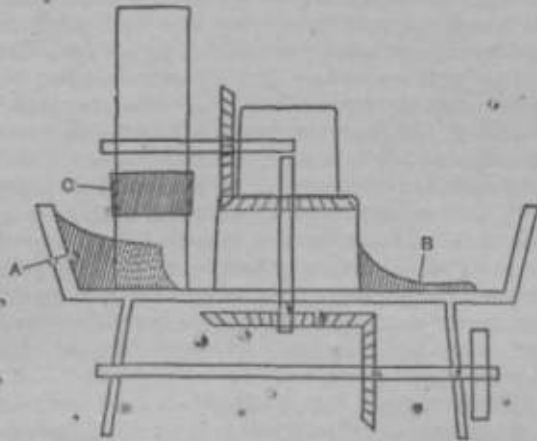
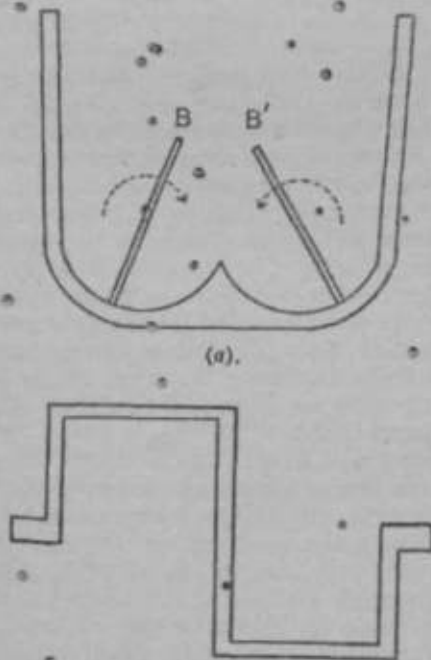

FIG. 2.

sides of the pan so that it collects in the path of the wheel. Grinding is by shear between the wheel and the floor of the pan. A screw-operated door is provided for emptying the mill.

Another useful mill, of the heavy-duty type, particularly for dealing with thick pastes, is the "Werner-Pfleider" or similar type. In section the mill is as shown in Fig. 3. The two blades,



Section of Blades

Fig. 3.

which are shaped as at (b), normally revolve in the direction indicated, but at slightly different speeds. The resulting shearing of the stiff mass leads to excellent dispersions.

Other mills, less commonly used, include the rod mills and mixers of the "Banbury" type.

#### TYPES OF PAINT AND THEIR USES.

Having dealt with the ingredients and the machinery used in the manufacture it may be opportune to consider the various classes of paints in use at the present time and the particular circumstances of their application. In the first place it will be convenient to consider separately two major classes of paint products: (i) those used for the decoration and protection of buildings, and (ii) those used in manufacturing processes either mass-produced or otherwise. Before proceeding with the first of these two groups, reference may be made to the admirable report on "The Painting of Buildings" (Post-war Building Studies, No. 5, H.M.S.O., 1945) and to the Codes of Practice at present under preparation by the British Standards Institution (Codes of Practice 2/4/1946, Decoration—Painting and Subsidiary Codes) in which a great deal of valuable information regarding the application of paint products has been collected.

The normal materials used in the painting of buildings include primers, undercoats, and finishes. Where wood is to be painted the primer is adapted to seal the porosity and make a firm key for subsequent coats. A white-lead primer has traditional support and is usually composed of white lead with up to an equal weight of extender ground in linseed oil. Some mixing varnish, thinners, and driers are added as required. For interior use, or where lead paints are objectionable, alternatives pigmented with Hthopone or titanium oxide are generally used, though Hthopone is not usually regarded as satisfactory for exterior exposure. The proportion of medium (or vehicle) will be adjusted so that a paint having a fair sheen but not a glassy finish is produced. For interior work, it may be desired also to adjust the drying time by altering the proportion of oil and varnish.

For Oregon and Columbian pine and similar woods of marked grain and consequent varying porosity it is usual to formulate a primer containing aluminium powder. This may be either of the normal type of aluminium powder dispersed in medium, or may consist of a mixture of such a material with a pigmented product. In the priming of metal, the first objective is the prevention of corrosion. By common usage, red-lead primers have been employed for steelwork and it is certain that the majority of craftsmen still favour their use. However, recent improvements in the properties of lead and zinc chromates makes these compounds quite attractive as alternatives. The red-lead primer of tradition is a simple dispersion of that pigment, with or without extender, in raw or boiled linseed oil (e.g., B.S. 1011). It has the disadvantage of being slow-drying and many variants are now produced in which varnishes have been added to reduce the interval necessary before the application of the subsequent coats of the system. Thus, extended red-lead paints are required by B.S. 1033 to dry within 5 hours. The number of possible chromate primers is very large and the whole range of vehicles is available for experiments. Attempts have been made to standardize some of these materials for special purposes in the specifications recently devised by the Ministry of Supply and Admiralty. The



priming of cement and plaster surfaces presents a wide field of investigation for the formulator. In general the chief problems concern the moisture content of immature surfaces, the alkaline reaction of cement and lime, the consequent risk of saponification of oil in the medium, and the varying porosity of plaster surfaces of different types and methods of finishing. The main object of priming must be to form a satisfactory basis for the subsequent coats and the vehicle content of the primer must be adjusted accordingly. It is not good practice to paint on alkaline surfaces until they are thoroughly dry, and even then the pigments and medium must be carefully selected.

Undercoatings, where they are applied, are designed to bring forward the surface to an even colour and suitable surface to receive the finishing coat. They are normally of good opacity and require the use of a high proportion of pigment to extend, the latter being used chiefly to adjust the gloss. It is necessary to bear in mind the suitability of an undercoat for the subsequent finish. It is useless to apply a hard, quick-drying finish over a soft undercoat. The proportion of oil to varnish component is therefore very important.

Finishing Coats applied in normal decorative practice are of extreme diversity of type. The principal classes may be summarised as follows:

1. Glass finishes:
  - (a) Oil type.
  - (b) Hard-gloss type:
    - (i) Natural gum type.
    - (ii) Synthetic'
  - (c) Enamels.
2. Eggshell and flat finishes (including the emulsion-type wall finishes).

The oil-type gloss finishes (commonly known as "ready-mixed" paints) are composed usually of pigment and an appreciable proportion of extender dispersed in raw linseed oil with perhaps the addition of boiled oil or lightly bodied stand oil and the necessary driers (cf. the composition formulas set out in B.S. 262, etc., and B.S. 920). They are generally of high weight per gallon, yield a rather soft and not very glossy film, and are useful for general maintenance work where protection's more important than appearance.

Hard-gloss paints, particularly those intended for interior use, may be made from a very wide variety of vehicles. For such interior finishes, the vehicle will usually have a gum-to-oil ratio approximating to 1:1. The actual gum or resin selected depends very much on the experience and personal preference of the operator but Congo copal and reduced phenol-formaldehyde resins have found extensive application, while newer resins as the maleic anhydride adduct of rosin or the cyclohexanone resins produced by I.G. Farbenindustrie had particular advantages in colour retention. The alkyds have given good performance, and particularly those modified with soyabean oil have excellent colour retention. Linseed-oil alkyds are rather prone to yellow in service but interior finishes having excellent levelling and flow properties and good gloss can be prepared from vehicles at about

60-55% oil-length. Some workers have favoured the addition of natural resin to increase the gloss but this practice is frequently attended by compensating disadvantages of increased yellowing and reduced durability.

For exterior gloss finishes most of the finishes already noted can be used satisfactorily although the oil-length of the vehicles will need to be increased, probably up to 70-75% for natural gums and reduced phenolics and not less than 60% for the alkyds. For exterior finishes, the pigmentation needs to be controlled more closely. The use, for example, of free-chalking forms of titanium oxide is not permissible unless suitable steps are taken to retard the rate of breakdown. Fugitive colours must be avoided, and due care must be taken to ensure that the pigmentation is compatible with any local condition of atmospheric pollution (e.g., to refrain from using titanium oxide in industrial districts where the atmosphere has a high content of sulphur dioxide).

Enamels are, by tradition, paints of rather low opacity but producing films with brilliant gloss and excellent flow. The original enamel\* were prepared from zinc oxide and extra pale Unseed stand oil. The precise significance of the term has now been lost except with the older craftsmen and "enamels" now include products based on synthetic resins. In general, however, the qualities of gloss and flow are still maintained.

Flat and Eggshell Finishes are usually employed for interior decoration and there has recently been a marked bias in favour of the eggshell gloss on account of the improvement over a flat finish in ease of cleaning and of its pleasant general appearance. "Flat" finish may be defined as that which produces only the slightest sheen when viewed at glancing incidence, while "eggshell" has a definite sheen for the ordinary viewpoint and approaching full gloss at glancing incidence. Both types are made by adjusting the proportion of pigment and medium. The cost factor will decide whether pure pigment or extender is to predominate, but it is essential that the finishes should have adequate opacity. Some manufacturers have used matting agents such as metallic stearates, and others have incorporated a small amount of wax in the finish. However, in view of its effect on the drying of subsequent paint coats this practice is not recommended.

Two important classes of decorative material very closely related to paint may be considered under this category. They are the *oil-emulsion* and *distemper* finishes. In the former, the ordinary vehicle of oil and gum dissolved in solvent is replaced by an emulsion of oil or oil varnish in water. Glue or casein is usually added as a "protective" colloid and there are present, in addition, small quantities of preservatives and stabilisers, although recent shortages of glue and casein have led to widespread investigation of other emulsions. The ingredients are usually mixed in a predetermined order and passed through some form of homogeniser to ensure the production of a satisfactory emulsion. The distemper class uses glue or casein, or a similar colloidal solution as the medium. The paint is specially suited to the manufacture of both

groups of water paints. The main difference between the types is that while the oil-emulsion products develop quite reasonable resistance to water after a short period, the oil-free materials are at once washed off if sponged down. The latter are usually employed for ceilings and other locations where washing down between paintings is not likely to occur. Both groups are cheaper to make and easier to apply than flat oil-paints and therefore find favour where first-class work is not required.

Certain auxiliary materials in general use by decorators may be noted before consideration of speciality finishing products which are being introduced to meet many important demands.

*Knottling*, commonly used as its name suggests for sealing the resinous exudation of knots in soft timber, is a solution of shellac in methylated spirits. Common *putty*, used for glazing and general stopping of imperfections, is a stiff paste of whiting (Paris white) in linseed oil. Decorators sometimes use a hard stopping mode on the job from white lead and gold-size (a quick-drying oleo-resinous varnish of short oil-length).

In the decoration and protection of industrial installations there arise conditions of humidity and involving the presence of chemicals which make very severe demands on the paint. Formerly, heavy coats of bitumen had been used wherever a greater resistance to corrosion was demanded. Recently, however, there has been a great drive to brighten up the appearance of factories and every effort has been made to develop satisfactory light-coloured paints. Paints that have given improved performance have been developed using chlorinated rubber, 100% phenolic resins, and more recently the vinyl polymers. Alcohol solutions of Manila copal form satisfactory paints for protecting battery terminals and boxes against sulphuric acid. The pigmentation and addition of plasticisers to these materials have a very great effect on the performance of the paint, and the exact formulations of these products are among the most jealously guarded secrets of the paint manufacturers.

A further class of decorative and protective paints that must not be overlooked is that used in the marine field. The interior decoration of passenger quarters of ships follows the broad principles already outlined, but the protection of a large area of steel plate requires special care in selection of primers. At the same time this extensive use of metal increases the troubles due to condensation, and the paints are therefore required to have increased water resistance. In other areas the maintenance painting of ships presents special problems. In particular, the hull below the water-line requires special attention. If the voyage is likely to be interrupted by calls in port of any but the briefest duration or if it extends into tropical waters, the paint film must not only be adequate for protective purposes, but must also have toxic properties towards animal and vegetable organisms which tend to attach themselves to the surface. These, if their growth is not controlled, offer considerable extra fractional resistance to the passage of the ship through the water, resulting in loss of fuel efficiency.\* (Details of fouling organisms

are given concisely in a pamphlet entitled "The Fouling of Ships' Bottoms: Identification of Marine Growth," London, The Iron and Steel Institute, 1944; see also Vol. III, 3836.) Paints formulated to combat fouling usually contain compounds of copper or mercury (or both). Some have recently experimented with organic poisons. The traditional medium for these paints is a solution of rosin with minor additions of plasticisers, etc. The efficiency of an "anti-fouling" paint depends on the rate of solution of the poison by sea-water, and the formulation must be adjusted so that this is neither too fast nor too slow to give optimum results. Between the permanently immersed part and that part which is always above the water line ("topsides") there is the area between the light and deep load lines generally known as the "boot-topping" area. Paints for this part have to withstand not only the immersion and splashing with sea water but also the full effect of normal weathering. In addition it is sometimes desired to include anti-fouling ingredients. Consequently, a compromise has to be made and most boot-topping paints have relatively poor durability. The topsides can be coated satisfactorily with good quality oil or synthetic paints but proper attention to priming is a paramount necessity. The same remarks apply to preparations of the superstructure for painting and also to the preliminary work on holds, ballast tanks, etc. In the latter situations it is convenient to use relatively quick-drying paints, provided these are not so brittle as to flake off readily in contact with cargo.

The preparation and composition of finishes for industrial use are very much more complex than those designed for the ordinary decorative market and it will be impossible in the scope of this article to give more than one or two general examples. A definite distinction is at once apparent in the method of application of the paint to the article to be coated. Most decorative paint (still probably around 95%) is applied by brush. For paints used in industry the figure is probably reversed and not more than 5% would be brush-applied. Great advances have been made in the development of spray technique and very many articles also are now coated by dipping. The other point of difference is that many articles painted in industry, from the smallest even a motor car, are capable of having the paint dried by application of heat. The means by which this is done vary with the article involved but there may be noted the alternative use of box and conveyor ovens and electric or gas "radiant heat" installations. It is not possible in this article to enter into a discussion of the relative merits of these alternatives and care should be taken by the user to consult both the paint manufacturer and the supplier of stoving equipment before settling on his process.

Material giving satisfaction for industrial use may be formulated from the whole range of vehicles. In recent years, however, the urea-formaldehyde and similar resins have attracted favourable comment by their property of being non-thermoplastic in the converted state, so that an article finished in these materials will be able to be stacked without risk of damage without a



long cooling period. The alkyds also have given good general service. Phenolic resins have found important specialised application in the electrical and food-canning industries, and in other uses where their particular properties make them of value.

The wider development of the paint industry, alongside the plastics industry, is one of the most active fields of research at the present time. For that reason this article has been kept intentionally in general terms and attempts only to indicate the fundamental principle of paint "science." For details of any specialised aspect, reference should be made to the appropriate section of this Dictionary or to the standard works on the subject, listed in the Bibliography below.

#### BIBLIOGRAPHY.

Books given in the following list may be consulted for further information on specific subjects.

- K. Gettens and O. L. Stout, "Tinting Materials, a Short Encyclopedia," New York, Int. Van Nostrand Co., Inc., 1942.
- N. Heaton, "Outlines of Paint Technology," 2nd ed., London, Griffin, 1940.
- J. J. Mott, ed., "Protective and Decorative Coatings," New York, John Wiley & Co., 1911, in progress. (5 volumes issued to date.)
- H. W. U. in til eld, "Varnish Constituents," London, Looney Ltd, 1944.
- E. F. Bennett, "A Review of Driers and Driftors," London, Paint Technology, 1940.
- A. E. Bailey, "Paints, Varnishes, and Related Products" (Chapter XIII of "Oil and Fat Products," by A. E. Bailey, New York, Interscience, 1945.)
- K. S. Storrell, and E. R. Wood, "The Chemistry of Drying Oils," London, Benn, 1925.
- T. H. Durrans, "Solvents," 5th ed., London, Chapman and Hall, 1944.
- O. Jordan (translated by A. D. Whitehead), "The Technology of Solvents," 2nd ed., London, Leonard Hill, 1940.
- I. Mollan, "Industrial Solvents," New York, Reinhold Publishing Corp., 1939.
- T. H. Barry, "Natural Varnish Resins," London, Benn, 1932.
- C. L. Mantell and other\*, "The Technology of Natural Resins," New York, John Wiley, 1932.
- C. L. Mantell, "The Production, Manufacture, Chemistry, Analysis, Commerce, and Uses," London, Pitman, 1935.
- C. E. B. B., "The Chemistry of Synthetic Resins," New York, Reinhold Publishing Corp., 1935.
- R. S. Morrell, ed., "Synthetic Resins and Allied Plastics," 2nd ed., London, Humphrey Milford, 1943.
- H. R. Stotids and M. H. J. J. J., "The New Plastics," New York, D. Van Nostrand, 1945.
- A. Jones, "Cellulose Lactone? Finishes, and Cements," London, Griffin, 1933.
- J. T. Marsh and V. C. Wood, "An Introduction to the Chemistry of Cellulose," 2nd ed., London, Chapman and Hall, 1942.
- C. Coffignier, "Varnishes, their Chemistry and Manufacture," London, Scott, Greenwood & Co., 1923.
- Oil and Colour Chemists' Association, "Varnish Materials" (papers read at Symposium held at Uxbridge in May, 1939), London, O.C.C.A., 1939.
- J. J. Fox and T. H. Bowles, "The Analysis of Pigments, Paints, and Varnishes," London, J. & S., 1927.
- H. A. Gardner, and U. O. Sward, "Practical and Chemical Examination of Paints, Varnishes, Lacquers, and Colours," 10th ed., Bethesda, Maryland, B. A. Gardner Lab. Inc., 1946.
- J. S. Remington, "The Paint Laboratory Notebook: a Handy Guide to Works Practice," 2nd ed., London, Leonard Hill, 1915.
- A. S. Jennings, "The Modern Painter and Decorator," London, Nixon Publishing Co., 1944.
- J. Lawrence, "Painting from A to Z," Mindwritter, Sutherland Publishing Co., 1935.
- B. H. Wainwright, "Modern Organic Finishes: their Application," London, Chemical Publishing Co., 1946.
- F. H. Crewdson, "Spray Painting, Industrial and Commercial," Wilcatro, F. J. Drake & Co., IMS.
- J. H. Nelson and H. Silinun, "The Application of Heat to Metal Finishing," 2nd ed., London, Chapman and Hall, 1915.
- Ministry of Works, "The Fainting of Enamels," London, H.M.S.O., 1944 (Post-war Publishing Series, No. 5).

Greater detail may be found in the following articles in the technical press:

O. Feamley, "Driers: a review," Official Digest, 1945, 245, 132; *ibid.* 1945, 249, 365.

J. C. Koenen, "The Newer Varnish Oils," Official Digest, 1945, 346, 240.

H. J. Wolfe, "Synthetic Drying Oils," Paint Manufacture, 1943, 15, 50.

H. BarTou, "Plasticizers and their Applications," Plastics, 1943, 7, 449.

H. B. Pollak, "Solvents in the Paint Industry," Paint, Oil, and Chemical Review, 1945, 108, No. 18, 0; No. 17, 1; No. 18, 22, 30; No. 19, 10; No. 20, 14, 22; No. 24, 20, 22; No. 25, 12; *ibid.* 1946, 109, No. 1, 12, 14; No. 2, 9, 12; No. 3, 10, 12, 14; No. 4, 10, 12, 14; No. 5, 5; No. 6, 16, 20, 21; No. 7, 12, 14, 15; No. 8, 18, 20, 52, 58; No. 9, 12, H, 16, 18, 20; No. 11, 8; No. 13, 10, 12; No. 15, 9, 12, 5\*; No. 16, 22, 24, 20; No. 17, 4; K, 1, 14, 16, 18.

S. J. Johnstone, "Minerals for the Paint Industry," J. Oil Col. Chem. Assoc. 1941, 24, 203.

A. E. Kramer, "Pigment Colours: a review," Official Digest, 1946, 262, 2.

H. Samuels, "Recent Advances in Pigments," J. Oil Col. Chem. Assoc. 1948, 31, 171.

A. H. Woodhead, "Recent Developments in Mineral Pigment Technology," Paint Manufacture, 1945, 15, 291, 3, 857.

R. Q. Barnes, "Ball and Pebble Mills as used in the Paint Industry," J. Oil Col. Chem. Assoc. 1946, 29, 182.

C. R. Draper, "Roll Mill Grinding," Paint Manufacture, 1943, 13, 20, 42, 67.

W. G. B. Mills, "Pigment Dispersion by Ball Mill," Oil and Colour Trades J. 1945, 108, 878, 920.

F. G. Duukiey and D. P. Earp, "The Limitations of Natural and Accelerated Weathering Panel Tests," J. Oil Col. Chem. Assoc. 1944, 27, 167.

V. G. JoUy, "The Effect of Exterior Exposure Tests on Paints and Varnishes," *ibid.* 1940, 23, 350.

E. G. N.

**PALLADIUM.** Sym. Pd, at. no. 46, at. wt. 106.7.

Occurrence.—Palladium is found in all native platinum, generally to the extent of 1-3% of the mineral. It also occurs in nickel sulphide ores, particularly those of the Sudbury district of Canada, from which the greater part of the world's supply of new palladium is now obtained. An alloy of gold with 8% of Pt occurs in small amounts in Brazil, in South Africa the mineral *stibiopalladinite*, Pd<sub>2</sub>Sb, occurs in some parts of the Merensky Reef, chiefly in the Potgietersrust area, while most parts of the reef contain the mineral *braggite*, (Pt,Pd,Ni)<sub>3</sub>Te. Braggite is an important source of palladium, forming an appreciable proportion of the platinum mineral concentrate obtained from the Kuiberg mines; about 10,000 oz. of palladium are obtained per annum from this source, compared with probably over 100,000 oz. per annum from the matte derived from smelting the Sudbury copper-nickel ores, and only a few thousand ounces from the whole of the world's output of native platinum.

Extraction.—Both the Sudbury and the Kuiberg ores are smelted to obtain a copper-nickel matte which is smelted with sodium sulphate and coke to separate the nickel and copper sulphides, the platinum group metals following the nickel. In the Mond process the nickel sulphide is roasted to oxide, which is reduced to nickel sponge with water gas; the **nickel** is then

Removed as carbonyl by treatment with carbon monoxide, and the residue is filtered with lead and silver to separate the platinum metals from base metal impurities. The lead alloy is cupelled, and the resulting silver bullion is boiled with sulphuric acid, which dissolves the silver and palladium; on cooling the acid most of the silver separates as sulphate; the remainder is precipitated as chloride and the palladium recovered from the filtrate by precipitation with pure zinc.

In the electrolytic process the nickel oxide is smelted to crude metal, which is refined by electrolysis in a nickel sulphate solution; the platinum metals accumulate in the anode slime, which is treated in a similar way to the carbonyl residues in the Mond process.

Pure palladium can be obtained by dissolving the crude metal, obtained as described above, in *aqua regia*, boiling the solution with hydrochloric acid to destroy nitro-compounds, adding ammonium chloride and cooling to precipitate any platinum, and then oxidising the solution with sodium chlorate or permanganate to precipitate ammonium chloropalladate,

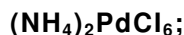

this precipitate is redissolved by boiling<sup>1</sup> with water until evolution of nitrogen ceases, and the solution is made ammoniacal, boiled until the pink precipitate first formed redissolves, filtered, and reacidified with hydrochloric acid to precipitate dichlorodiamminopalladium,

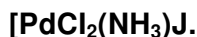

After cooling the yellow crystals are collected on a filter, washed with cold water, dried, and heated in air to expel ammonia and chlorine and leave a residue of slightly oxidised palladium sponge; this is converted into the pure metal by heating in hydrogen and cooling in carbon dioxide or pure nitrogen to avoid occlusion of hydrogen by the sponge.

In the refining of platinum mineral (v. PLATINUM, Vol. X) palladium remains in the mother-liquors from the ammonium chloroplatinate precipitation; the solution also contains rhodium and iron, copper, and other base metals. When the solution is warmed with sodium chlorate or permanganate and more ammonium chloride, the palladium is precipitated as crude ammonium chloropalladate. If this precipitate is boiled with water and the solution cooled, traces of platinum and iridium separate, as ammonium chloroplatinate and chloroiridate; concentration of the filtrate and addition of more ammonium chloride afford on cooling brown crystals of ammonium chloropalladate. These crystals are separated from the mother-liquor and dissolved by boiling with ammonia to give tetrammine-palladous chloride solution, from which the palladium is recovered as dichlorodiamminopalladium on addition of hydrochloric acid.

Properties.—Palladium is a silvery-white metal of density 11.96 at 18°C. It has a cubic face-centred lattice with  $a=3.8825\text{Å}$ . (E. A. Owen and J. I. Jones, Proc. Physical. Soc. 1937, 49, 587). It melts at  $1554.4^\circ\text{C}$ . and is therefore

the most readily fusible of the platinum group metals; it can readily be vaporised in the arc. At temperatures around the melting-point palladium is appreciably volatile even in a neutral atmosphere. The thermal conductivity is 0.161 c.g.s. units at 0°C. and 0.177 at 100°C. The thermal expansion for the range 20-1,000°C. is given by Holtzmann (Siebert Festschrift, 1931, 147), as  $l_t=l_{20} [1+(1.0637 \times 10^{-5})(t-20) + (4.594 \times 10^{-9})(t-20)^2 - (1.521 \times 10^{-12})(t-20)^3]$ . Up true specific heat at temperatures up to the melting-point is given by the expression  $c_p=0.058378+(1.20548 \times 10^{-6})t - (2.58 \times 10^{-10})t^2$  (F. M. Jaeger and W. A. Veenska, Proc. K. Akad. Wetensch. Amsterdam, 1931, 34, 15). The electrical resistivity of palladium is 10.63 microhm-cm, at 0°C, 14.3 at 100°C., and 400 at 1,000°C. The best value for the temperature coefficient of resistance is probably 0.00377 for wire annealed at 1,000°C. Palladium is thermoelectrically negative to platinum, the e.m.f. at 1,500°C. of a palladium-platinum couple being -22.74 millivolts.

The hardness of pure annealed palladium is about the same as that of platinum (Vickers pyramid hardness 37), but the commercial metal has an average hardness of 45 after annealing at 800-1,000°C. Cold-rolling rapidly increases the hardness to a maximum of about 110 V.P.H. after 60% reduction in thickness. The effect of alloying with other metals on the hardness of the annealed metal is shown below.

Alloying metal, %	Vickers pyramid hardness number			
	5	10	15	20
Ruthenium . . . . .	110	180	—	—
Nickel . . . . .	88	132	168	185
Iridium . . . . .	65	90	120	157
Osmium . . . . .	65	82	98	130
Copper . . . . .	68	85	102	110
Silver . . . . .	63	78	87	95
Rhodium . . . . .	55	64	78	85
Platinum . . . . .	47	50	55	60

Annealed palladium has a tensile strength of 12-13 tons per sq. in. with an elongation of 40%, but its proportional limit is only about 2 tons per sq. in. The metal is very ductile and malleable and can readily be beaten out into leaf as thin as  $4 \times 10^{-6}$  in. The hard-worked metal commences to soften at about 700°C, but maximum ductility is obtained only by annealing at 600-900°C; this annealing is preferably carried out in an inert atmosphere since the metal oxidises readily in air in the range 400-800°C. Alternatively the metal may be given a very short anneal at 900°C and quenched in water containing a little alcohol.

Palladium readily absorbs hydrogen; when the absorption takes place cathodically the maximum amount of gas taken up approaches the composition Pd<sub>2</sub>H, but by exposing the metal to hydrogen under pressure the composition PdH is closely approached. Absorption of hydrogen increases the hardness, tensile strength, and electrical resistance of the metal and decreases its ductility and density. Palladium thimbles are used for "filtering" hydrogen into special furnaces and other apparatus where very pure hydrogen is required

(E. 8. Giffillan, Trans. Electrochem. Soc. 1940, 77, 43). Palladium-hydrogen is a powerful reducing agent and can be used for the catalytic hydrogenation of oils and fats, although nickel is generally preferred for this purpose.

Palladium is not attacked by hydrofluoric, acetic, or phosphoric acids, or by dilute halogen acids or sulphuric acid. It dissolves in hot concentrated sulphuric acid slowly, but more rapidly in presence of an alkali sulphate or ammonium sulphate. Nitric acid, *aqua regia*, and the halogens dissolved in hydrochloric acid readily dissolve the metal, as also do bromine, chlorine, ferric chloride, and hypochlorite solutions. Iodine stains palladium black owing to the formation of the insoluble di-iodide, but sulphur has little tarnishing action at room temperature.

Alloys.—Palladium alloys with most metals; the binary systems with the following metals have been more or less systematically studied: antimony (A. T. Grigoriev, Z. anorg. Chem. 1932, 209, 308); beryllium (O. Winkler, Z. Metallk. 1938, 30, 162); boron (A. Sieverts and K. Bruning, Z. physikal. Chem. 1934, 168, 412); carbon (G. Siebert, D.R.P. 652,034); chromium (G. Grube and B. Knabe, Z. Elektrochem. 1936, 42, 793); cobalt (G. Grube and H. Kastner, *ibid.* 1936, 42, 156); copper (B. Buer, Z. anorg. Chem. 1911, 61, 223; B. Taylor, J. Inst. Metals, 1934, 54, 255; F. W. Jones and C. Sykes, *ibid.* 1939, 65, 419); gold (W. Fraenkel and A. Stern, Z. anorg. Chem. 1927, 166, 166); iron (A. T. Grigoriev, *ibid.* 1932, 209, 295; B. Hultgren and C. Zapffe, Trans. Amer. Inst. Min. Met. Eng. 1939, 188, 68); lead (B. Buer, Z. anorg. Chem. 1907, 52, 345); manganese (G. Grube and O. Winkler, Z. Elektrochem. 1939, 45, 784); nickel (F. Heinrich, Z. anorg. Chem. 1913, 82, 322; W. Fraenkel and A. Stern, *ibid.* 1927, 166, 164); rhodium (G. Tammann and H. J. Bocha, Siebert Festschrift, 1931, 309); silicon (P. Lebeau and P. Jolibois, Compt. rend. 1908, 146, 1028); silver (B. Buer, Z. anorg. Chem. 1906, 51, 315). Alloys of palladium with 40% of copper, and with 80-90% of silver are used for electrical contacts. Gold-palladium alloys are used in dentistry; the 80:20 alloy has been employed as a substitute for platinum in making laboratory crucibles and dishes. Silver-copper-palladium alloys are used for cast dental plates and for making fountain pen nibs.

Uses.—Pure palladium contacts are used in telephone relays, palladium leaf is used for producing white non-tarnishing decorative effects, and palladium plating is used for producing white finishes on cheap jewellery. Hardened palladium is used as a substitute for platinum in jewellery, and palladium salts are employed in making special photographic printing papers\*. Solutions of palladous chloride or the double potassium sulphite are used for detecting carbon monoxide in the air of mines, etc. Various forms of palladium are used as hydrogenation or oxidation catalysts, the most useful form being 5% palladised asbestos. Colloidal solutions of palladium are also employed as catalysts.

#### PALLADIUM COMPOUNDS.

Oxides.—*Palladium Monoxide*, PdO, is obtained in hydrated form as a brown precipi-

tate when palladous chloride or nitrate solution is boiled with a slight excess of alkali hydroxide or carbonate. The precipitate becomes darker on drying, but does not lose all its water until heated above 500°; at above 800° it, loses oxygen and is converted into the metal. The anhydrous oxide can be obtained by decomposing the nitrate by heating, or by careful oxidation of the finely-divided metal in oxygen; the oxide prepared by these methods is difficultly soluble in acids, whereas the precipitated hydrated oxide readily dissolves in mineral acids and in excess of caustic alkalis.

*Palladium Sesquioxide*, Pd<sub>2</sub>O<sub>3</sub>, is obtained as a hydrated brown precipitate at the anode on electrolysing a cold concentrated solution of palladous nitrate; it is unstable and readily decomposed by acids giving palladous salts.

*Palladium Dioxide*, PdO<sub>2</sub>, is obtained as a brown hydrated precipitate resembling precipitated manganese dioxide\* by boiling a neutral solution of sodium chloropalladite with sodium bromate or, like manganese dioxide, by boiling a solution of the nitrate with sodium chlorate or, better, bromate. On drying, the precipitate darkens and retains one molecule of water very tenaciously. It dissolves in cold hydrochloric acid forming a solution of palladic chloride; boiling nitric acid slowly decomposes it, forming palladous nitrate. Hydrogen reduces it to metal with incandescence; on heating at 200° it decomposes into the monoxide.

Fluorides.—Hygroscopic black rhombic crystals of *palladium trifluoride*, PdF<sub>3</sub>, are obtained by heating palladium sponge at 500-600°C. first in chlorine and then in fluorine. Treatment of the solution with reducing reagents affords the *dichloride*, PdCl<sub>2</sub>, which can also be obtained by treating the dichloride with hydrogen fluoride (Buff and Ascher, *ibid.* 1929, 183, 193).

Chlorides.—*Palladium Chloride*, PdCl<sub>2</sub>, sublimes as dark-red needles when palladium sponge\* or the monosulphide is heated in dry chlorine. The dihydrate, PdCl<sub>2</sub>·2H<sub>2</sub>O, crystallises as a brown hygroscopic mass\* on evaporating a solution of the metal in hydrochloric acid and chlorine, or in *aqua regia*. It is soluble in water, giving a brown solution from which silver nitrate precipitates PdCl<sub>2</sub>·2AgOH. Similar compounds are given by addition of lead and thallium nitrates, indicating that palladous chloride in solution may act as a dibasic acid, H<sub>2</sub>[PdCl<sub>2</sub>(OH)<sub>2</sub>]. Palladous chloride forms stable double salts with chlorides of the alkalis, alkaline earths, magnesium, zinc, cadmium, nickel, manganese, and ammonium; these compounds are usually formulated as derivatives of *chloropalladous acid*, H<sub>2</sub>PdCl<sub>4</sub>, although the acid itself has not been isolated. The chloropalladites are all soluble in water, usually crystallising in brown needles. The caesium and rubidium salts are the least soluble. Ignition of the ammonium salt affords palladium sponge with high catalytic activity.

*Palladic Chloride*, PdCl<sub>4</sub>, is not known in the free state, but only as double salts of the type M<sub>2</sub>PdCl<sub>6</sub>, corresponding to the chloroplatinates, with which they are isomorphous. They are relatively unstable, and on boiling with water revert to chloropalladites with evolution of

Chlorine. \* Potassium, rubidium, and caesium chloropalladates are red to brownish-red insoluble salts formed by treating the corresponding chloropalladate in dilute hydrochloric acid solution with chlorine or, better, the alkali metal permanganate.

*Ammonium Chloropalladate*,  $(\text{NH}_4)_2\text{PdCl}_6$ , is precipitated as red octahedra by addition of sodium chlorate or potassium permanganate to a warm solution of ammonium and palladous chlorides in dilute hydrochloric acid. The salt is quite stable at room temperature, but rapidly decomposes in hot water with evolution of nitrogen and formation of palladous chloride.

Palladous Bromide,  $\text{PdBr}_2$ , is obtained by dissolving precipitated palladium in bromine-hydrobromic acid and boiling off the excess of bromine. It resembles the corresponding chloride in its properties and reactions. Bromopalladates and -palladates are also known.

Palladous Iodide,  $\text{PdI}_2$ , is precipitated as a flocculent black compound by adding a soluble iodide to a slight excess of palladous chloride solution. \* It readily dissolves in excess of potassium iodide solution and yields iodine and palladous oxide on roasting in air at 300-400°.

Palladous Sulphide,  $\text{PdS}$ , is a brown precipitate formed by passing hydrogen sulphide through palladous chloride solution; it is probably hydrated. On heating ammonium chloropalladate with sulphur a dark greyish-black metallic mass of  $\text{PdS}$  is obtained which melts at 950°, losing sulphur and forming globules of a eutectic of palladium and a sub-sulphide which resemble mercury in appearance while molten. Complete expulsion of sulphur by roasting in air is very difficult owing to the fusibility of this eutectic. *Alkathio-palladates* and -palladates have been prepared by fusing alkali hydroxides with sulphur and palladous sulphide in various proportions,

palladous Sulphate,  $\text{PdSO}_4 \cdot 2\text{H}_2\text{O}$ , separates in brown deliquescent crystals when a solution of palladium in concentrated sulphuric acid is diluted slightly and allowed to crystallise. It hydrolyses on boiling with much water, yielding a brown flocculent precipitate of basic sulphate.

Palladous Nitrate,  $\text{Pd}(\text{NO}_3)_2$ , crystallises as deliquescent brownish-yellow, orthorhombic prisms when a solution of palladium sponge in nitric acid is evaporated and cooled; its solution in water hydrolyses on boiling with the formation of basic salts of indefinite composition.

Palladonitrites,  $\text{MJPd}(\text{NO}_2)_4$ , are formed by boiling palladous chloride or nitrate solution with excess of alkali nitrite. The potassium salt,  $\text{K}_2\text{Pd}(\text{NO}_2)_4 \cdot 2\text{H}_2\text{O}$ , readily crystallises in efflorescent, yellow, triclinic prisms. A solution of this salt in water acidified with a few drops of sulphuric acid and containing sodium sulphate as conducting salt can be used for palladium plating.

Palladous Cyanide,  $\text{Pd}(\text{CN})_2$ , is formed as a yellow flocculent precipitate when mercurous cyanide is added to palladous chloride solution; this reaction serves to separate palladium from the other platinum metals. On ignition palladous cyanide affords palladium sponge, with evolution of cyanogen.

### Potassium Palladocyanide,



crystallises in colourless rhombic needles when a solution of palladous cyanide in potassium cyanide is evaporated. It is isomorphous with the corresponding platinum compound, loses  $2\text{H}_2\text{O}$  at 100°, and becomes anhydrous at 200°.

**Palladium Amines.**—When ammonia is added to a solution of ammonium chloropalladate a pink precipitate is first formed, but this dissolves on boiling and the solution yields colourless needles of *tetrammine palladous chloride*,  $[\text{Pd}(\text{NH}_3)_4]\text{Cl}_2$ , on cooling; this compound readily dissolves in water, giving a colourless solution from which hydrochloric acid precipitates bright yellow crystals of *diclorodiamminopalladium*,  $[\text{PdCl}_2(\text{NH}_3)_2]$ . The pink crystals mentioned above have the same empirical formula as these yellow crystals but are generally considered to be *tetramminepalladium chloropalladate*,  $[\text{Pd}(\text{NH}_3)_4\text{Cl}_2]$ . Addition of excess of ammonia to palladium nitrate solution followed by boiling affords colourless needles of *tetrammine palladous nitrate*,

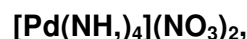

which does not give a diamminonitrate-compound when treated with nitric acid; with hydrochloric acid, however, yellow  $[\text{PdCl}_2(\text{NH}_3)_2]$  is precipitated. Palladonitrites with ammonia yield *diamminodinitropalladium*,



which exists in *tie-* and *frana-* modifications; a solution of these compounds in ammonia furnishes a useful palladium plating solution.

### DETECTION OF PALLADIUM.

The characteristic reactions serve to distinguish palladium from all other metals; viz. (1) precipitation of black palladous iodide when potassium iodide is added to the chloride solution; (2) precipitation of yellow flocculent palladous cyanide when mercuric cyanide is added to a neutral chloride solution, and (3) formation of a bright yellow voluminous crystalline precipitate when an acid chloride solution is treated with dimethylglyoxime solution. Hydrazine precipitates metallic palladium from boiling solutions of the chloride, sulphate or aminino compounds; ferrous sulphate or alcohol precipitates the metal from boiling strongly acid sulphate solutions.

A. R. P

, PALM OIL (t; this Vol., p. 166).

**PALM SUGAR.** *Our Jaggery.* A brown crude sugar obtained by collecting the sap from certain tropical and sub-tropical palm trees; only a small proportion of the production is refined until it is white and granular. The names and habitat of the trees chiefly utilised for this purpose are: *Arenga saccharifera*, sago palm, wild in Assam and Burma, cultivated in India; *Borassus flabellifer*, Palmyra or toddy palm, tropical Asia and America; *Caryota urens*, Indian sago or kitul palm, India and Burma;

*Cocos nucifera*, coco-nut palm, East and West Indies; *Nipa fruticans*, nipa palm, Philippine Islands; *Phymix silvestris*, toddy palm, wild date palm, East Indies.

Browning and Symons (J.S.C.I. 1916, 35, 1138) describe the tapping of the coco-nut palm in Geylon. The native tapper climbs the tree and cuts off a small piece from an undeveloped flower-spathe, and attaches a pot to the stump to collect the sap. The maximum daily yield was 4,738 c.c.; the total yield per spathe varied from 3 to 17J gallons. A small amount of slaked lime is placed in each collecting pot, which has the effect of checking the otherwise rapid spontaneous fermentation of the sap. The freshly-collected sweet toddy contains 12-3-17\*4% of sucrose and is consumed as a beverage. The fermented effervescing juice is known as toddy or palm wine. There is a large demand for the potable spirit, arrack (v. Vol. I, 467), which is distilled, by wasteful native methods, from the fermented toddy. Vinegar, containing up to 6% of acid, as acetic acid, is an alternative manufacture, carried out by prolonged exposure of toddy to the air.

The juice not consumed as a beverage is evaporated in iron pans until a sample sets on cooling.

One gallon of sweet toddy yields about 1\$ lb. of jaggery or crude sugar.

Gibbs (*ibid.* 1911, 30, 1133) describes similar processes in the Philippines with the juice of the nipa palm which he considers to be an economic source of power-alcohol. The jaggery from the nipa-palm juice contained: sucrose, 88-2; glucose, 3-3; water, 60; ash, 2-92%. Milsum and Dennett (B. 1930,435) who studied products from *Arenga saccharifera* estimate that about 70% of the sugar in the sap could be obtained as white sugar of 99% polarisation. Roxas (*ibid.* 1930, 436) adds sodium bisulphite to the sap to destroy a peroxidase which is present. The sap of *Borassus flabellifer* contains 10 mg. of ascorbic acid in 100 c.c. (Mitra, Amer. Ghem. Abstr. 1942, 36, 2033). For analyses of coco-nut toddy, see Gowap *et al.*, *Analyst*, 1932, 57, 627. Rae *et al.* (Amer. Ghem. Abstr. 1941, 35, 5740) estimate the annual production of palm sugar and jaggery in India to be 130,000 tons. Detailed information of the sugar palms is given by G. Watt, "Commercial Products of India," London, 1908; I. H. Burkill, "Economic Products of the Malay Peninsula," 2 vols., Crown Agents for the Colonies, London, 1935.

J. N. G.

**PALUDRINE.** N-j-<sup>1</sup>-Chlorophenyl-N<sub>6</sub>-isopropyl diguanide (biguanide). Antimalarial drug (v. SYNTHETIC DRUGS).

S. E.

**PAMAQUIN.** 2,3-Dihydroxy-1,1'-dinaphthylmethane-3:3'-dicarboxylic acid salt of 6-methoxy-8-[8-diethylamino-a-methylbutylamino] quinoline. "Plamaquin." Antimalarial drug. B.P. Add. IV and VI; B.P.C. Supp. III and VI (v. SYNTHETIC DRUGS).

S. E.

**PANTOCAINE.** Dimethylaminoethyl-p-butylaminobenzoatehydrochloride. "Decicain." Local anaesthetic (v. SYNTHETIC DRUGS).

S. E.

## PANTOTHENIC ACID,



was the first vitamin to be discovered, isolated, and synthesised using as a basis an entirely new approach. Other vitamins had been discovered and concentrated because of their physiological effects on animals; pantothenic acid was discovered and concentrated because of its effectiveness as a growth substance for micro-organisms (Williams *et al.*, J. Amer. Ghem. Soc. 1933, 55, 2912; 1938, 60, 2719; Snell, Strong, and Peterson, *ibid.* 1938, 60, 2825).

The use of micro-organisms in vitamin research has been extremely productive (Williams, *Science*, 1941, 93, 412). Biotin had been isolated by Kögl as a substance promoting the growth of yeast in 1935; its vitamin properties were recognised in 1940; its structure and synthesis reported in 1942 and 1943 (see review, Hofmann, *Adv. Enzymology*, 1943, in, 289). The vitamin properties of inositol, nicotinic acid, p-amino benzoic acid, pyridoxal, pyridoxamine, and folic acid have likewise been recognised as a result of microbiological studies.

The name pantothenic acid (Greek, from everywhere) was given this substance because of its ubiquitous occurrence in diverse forms of living material. Evidence for its existence in the following biological phyla: Chordata, Arthropoda, Echinoderms, Molluscs, Annulata, Plathyminthes, Myxomycetes, Bacteria, Fungi, Algae, Spermatophytes, was presented in 1933 (Williams *et al.*, J. Amer. Ghem. Soc. 1933, 55, 2912). It is the first vitamin which has not been given an alphabetical name. Since its widespread occurrence was noted it has been found that other vitamins generally are likewise widely distributed in all organisms tested (Wood *et al.*, Univ. of Texas Publ. 1942,4237, 84).

**Distribution.**—The richest common source of pantothenic acid is liver, but "royal jelly" used by bees may be as much as 6 times as rich (Pearson and Burgin, *Proc. Soc. Exp. Biol. Med.* 1941, 48, 415). Yeast is a rich source; fresh vegetables and fruits are relatively good food sources (Gheldelin and Williams, Univ. of Texas Publ. 1942,4237,105). Pantothenic acid originates during the growth of green plants (McBurney, Bollen, and Williams, *Proc. Nat. Acad. Sci. [U.S.A.]*, 1935, 21, 301) and certain bacteria (Thompson, Univ. of Texas Publ. 1942, 4237, 87) including those in the rumen of cattle (Wegner *et al.*, *Proc. Soc. Exp. Biol. Med.* 1940, 45, 769) but not, so far as is known, in the tissues of higher animals. It was early found that pantothenic acid exists in tissues in a bound condition (Rohrman, Burget, and Williams, *ibid.* 1934, 82, 473) and is released only by autolysis or other enzymatic action. Subsequently this was found also to be true for other B-vitamins (Williams, Univ. of Texas Publ. 1941, 4137, 8; Gheldelin *et al.*, *ibid.* 1942, 4237,15)

**Isolation.**—The isolation of pantothenic acid from natural sources is extremely difficult. Three relatively large-scale attempts have been made to do this. Williams and co-workers (J. Amer. Chem. Soc. 1938, 60, 2719) obtained about 3 g. of 40% pure calcium salt and small quantities of salt of over 90% purity from 250 kg.

of sheep liver. The liver was autolysed to obtain a clear filtrate, undesirable parts were removed using fiber's earth, and the active principle was adsorbed on activated charcoal. The charcoal was then eluted and the eluate evaporated to dryness on Kieselguhr in the presence of brucine and biucine oxalate. The residue was extracted with dry chloroform and the mixture of brucine salts was fractionated by a laborious process, involving distribution between immiscible solvents. This step alone occupied about 6 months. The brucine salts thus obtained were converted to the stable calcium salt and fractionated further with solvents and solvent mixtures.

Subbarow and Hitchings (*ibid.* 1939, 61,1616) followed a modified procedure based upon that of Williams and obtained 510 mg. of about 75% pure calcium salt from 160 kg. of liver.

Kuhn and Wieland (Ber. 1940, 73 [B], 962) started their work with 4 kg. of fresh tunny liver. They used various precipitation procedures to remove inert material, and charcoal to adsorb the active substance. By precipitating the active principle with barium hydroxide in methanol and making use of chromatographic adsorption on alumina they obtained material of about 6% purity. They obtained pure pantoic lactone from this product and concluded that pantothenic acid from this source was identical with that obtained by Williams from mammalian liver. Stiller, Keresztesy, and Finkelstein (J. Amer. Chem. Soc. 1940, 62, 1779) had previously isolated pantoic lactone from liver concentrates of pantothenic acid.

**Quantitative Determination.**—The most widely used methods for the quantitative determination of pantothenic acid are based upon the original findings of Snell, Strong, and Peterson (*ibid.* 1938, 60, 2825) and involve the use of *Lactobacillus casei* as the test organism. Various interfering substances have been discovered and means of overcoming most of them have been devised (Thompson, Cunningham, and Snell, J. Nutrition, 1944, 28, 123). A number of other bacteria have also been used for pantothenic acid assay: *Proteus morgani* (Pelczar and Porter, J. Biol. Chem. 1941, 139, 111), *Streptococcus lactis* (Mitchell *et al.*, J. Amer. Chem. Soc. 1940, 62, 1776), *Streptobacterium plantarum* (Kuhn and Wieland, Ber. 1940, 73 [B], 962), and *Lactobacillus arabinosus* 17-5 (Skeggs and Wright, J. Biol. Chem. 1944, 156, 21; Hoag, Sarett, and Cheldelin, Ind. Eng. Chem. [Anal.], 1945, 17, 60). Some of these, especially the last, have advantages over the widely used *L. casei*.

In case micro-organisms are used for assay organisms the pantothenic acid must be brought into solution before the tests can be applied. Bound forms must be rendered available, and the completeness of the extraction determines in part the character of the result (Cheldelin *et al.*, Univ. of Texas Publ. 1942, 4237, 15).

Chicks have been used most extensively for pantothenic acid assay by Jukes (J. Biol. Chem. 1937, 117, 11; J. Nutrition, 1941, 21, 193). Such a determination requires a two-week growth-period and has obvious disadvantages, but bound forms of pantothenic acid are presumably rendered completely available in the

digestive tract. Values obtained by the chick method agree in general with the bacteriological methods, but there are discrepancies in the case of some materials, notably yeast, which have not been completely elucidated.

**Synthesis.**—Pantothenic acid may be synthesized by the interaction of a  $\beta$ -alanine ester and pantoic lactone. Williams and co-workers first used this method on a small scale using the crude lactone from natural sources (Science 1939, 89, 486; J. Amer. Chem. Soc. 1940, 62, 1784). Stiller *et al.*, (*ibid.* 1940, 62, 1779) identified the lactone from pantothenic acid as  $\alpha$ -hydroxy- $\beta$ -dimethyl- $\gamma$ -butyrolactone, which had previously been synthesized by Glaser (Monatsh. 1901, 22, 66), and developed the synthesis on a practical scale (Stiller *et al.*, J. Amer. Chem. Soc. 1940, 62, 1785). This synthesis was also developed independently by Reichstein and Grüssner (Helv. Chim. Acta, 1940, 23, 650) and Kuhn and Wieland (Ber. 1940, 73 [B], 971), who in the latter case used the benzyl ester and subsequently removed the benzyl group by hydrogenolysis.

The use of  $\beta$ -alanine esters is undesirable, due to their instability and to the fact that after condensation the ester group must subsequently be removed by a mild treatment which will not cleave the pantothenic acid itself. Hydrolytic cleavage of aliphatic esters without substantial cleavage of the acid can, however, be accomplished. Another method which obviates these difficulties involves the interaction between pantoic lactone and a salt of  $\beta$ -alanine. This was first done with crude lactone and later in excellent yield by melting together the dry lactone and sodium salt (Williams *et al.*, J. Amer. Chem. Soc. 1940, 62, 1784). Babcock and Jukes (*ibid.* 1940, 62, 1628) carried out the same reaction using an aqueous solution. Moore (U.S.P. 2234680, 1941) has obtained pantothenic acid by condensation of pantoic lactone with free  $\beta$ -alanine.

**Stereochemistry.**—Pantothenic acid exists in two optically active forms, since the pantoic group bears an asymmetric carbon atom. Natural pantothenic acid in the form of a pale yellow viscous oil is dextrorotatory  $[\alpha]_D^{25} +37.5^\circ$ . The calcium and sodium salts are likewise dextrorotatory, with rotatory powers  $[\alpha]_D^{25} +24.3^\circ$  and  $[\alpha]_D^{25} +27.04^\circ$  respectively. The lactone is laevorotatory  $[\alpha]_D^{25} -49.8^\circ$ , and yields a strongly dextrorotatory amide  $[\alpha]_D^{25} +52^\circ$  and was concluded to have the  $\Lambda$ -configuration.

Synthetic pantoic lactone has been resolved using quinine methohydroxide (Major and Finkelstein, J. Amer. Chem. Soc. 1941, 68, 1368); pantothenic acid has been resolved by the use of quinine and cinchonine salts (Stiller *et al.*, *ibid.* 1940, 62, 1785; Kuhn and Wieland, Ber. 1940, 73 [B], 971; *ibid.* 1941, 74 [B], 218) and by use of its quinine methohydroxide salts (Stiller and Wiley, J. Amer. Chem. Soc. 1941, 63, 1237). Only the natural form of pantothenic acid is physiologically active in organisms so far examined.

**Physiological Activity.**—Since pantothenic acid is an indispensable constituent of all kinds of



organisms, it must, in the case of each organism, either be synthesised by the organism or furnished as a nutrient. In the latter case the organism will, under appropriate conditions, give a growth response to pantothenic acid. Such growth responses have been observed in the case of yeasts, various bacteria, moulds, liverworts, seedling plants, protozoa, insects, fowls, mice, rats, dogs, hogs, and monkeys (Williams, *Adv. Enzymology*, 1943, m, 253).

The first observations which may be attributed to the effects of pantothenic acid were those of Wildiers (*La cellule*, 1901, 18, 313), who postulated the existence of a hypothetical substance, "bios," indispensable for the growth of yeast. Though the effect observed at that time was somewhat mixed, it is clear that pantothenic acid was involved, since in some experiments "bios" was destroyed by mild alkaline treatment and biotin is thereby ruled out as the active substance.

The first animal experiments in which a pantothenic acid effect was involved were probably those of R. L. Williams and Waterman (*J. Biol. Chem.* 1928, 78, 311), who discovered "vitamin-B<sub>3</sub>" an unidentified factor essential for pigeons. According to present evidence, pantothenic acid was the outstanding agent involved (Lee and Hogan, *Missouri Agric. Exp. Sta. Res. Bull.* 1942, 342; Carter and O'Brien, *Biochem. J.* 1939, 83, 1810). "Chick dermatitis" was discovered later (Norris and Ringrose, *Science*, 1930, 71, 643; Kline *et al.*, *J. Biol. Chem.* 1932, 99, 295). This also involves pantothenic acid deficiency primarily though in the earlier experiments, at least, other deficiencies were superimposed.

In chicks a deficiency of pantothenic acid causes a cessation of growth in which all of the tissues become deficient and affected (Snell, Pennington, and Williams, *ibid.* 1940, 133, 559). Spinal-cord lesions, as well as thymus involution, keratitis, dermatitis, and fatty livers, were found to accompany pantothenic acid deficiency (Phillips and Engel, *J. Nutrition*, 1939, 18, 227). Feather depigmentation in black chickens has also been observed to accompany pantothenic acid deficiency (T. C. Groody and M. E. Groody, *Science*, 1942, 95, 655). Hens on a pantothenic acid-free diet continued to lay eggs but the eggs were poor in pantothenic acid and their hatchability was nearly zero (Gillis, Heuser, and Norris, *J. Nutrition*, 1942, 23, 153). Increasing the content of eggs by feeding pantothenic acid can be accomplished (Snell and Quarles, *ibid.* 1941, 22, 483), and such a result increases the hatchability of the eggs (Taylor, Thacker, and Pennington, *Science*, 1941, 94, 642). The pantothenic acid requirement of chicks according to Jukes is about 1.4 mg. per 100 g. of diet.

In young rats a deficiency of pantothenic acid causes adrenal cortex atrophy (Daft and Sebrell, *U.S. Pub. Health Rep.* 1939, 54, 2247; Daft *et al.*, *ibid.* 1940, 55, 1333) as a prominent effect. A number of the symptoms such as increased appetite for salt, "blood caked whiskers," may be attributed to this damage. Another prominent effect is greying of the hair which has been experimented with in many laboratories (Williams, *Adv. Enzymology*, 1943, ni, 253). While other factors may cause greying of hair,

pantothenic acid deficiency regularly has this effect in rats—a condition which can be reversed by pantothenic acid administration, in addition to those conditions, already mentioned, haemorrhages under the skin (Unna, *J. Nutrition*, 1940, 20, 565), kidney and heart damage and sudden death (Supplee, Bender, Kahlenberg and Babcock, *Endocrinology*, 1942, 30, 355), thinness of epiphyseal cartilage of the tibia (Ashburn, *U.S. Pub. Health Rep.* 1940, 55, 1337) have been attributed to pantothenic acid deficiency. An abundant supply of pantothenic acid causes an increased litter size in rats (Taylor, Pennington, and Thacker, *J. Nutrition*, 1943, 25, 389).

The daily requirements of pantothenic acid for laboratory rats is 80 pg. to 100 pg. The requirement decreases with age (Unna and Richards, *ibid.* 1942, 23, 545).

The status of pantothenic acid as a vitamin for mice is complicated by interrelations with inositol. Greying of hair in mice has been observed as a result of deficiency, and under proper conditions extensive loss of hair (alopecia) can be produced by deficiency of pantothenic acid and cured by its administration (Martin, *Science*, 1941, 93, 422; Woolley, *J. Exp. Med.* 1942, 75, 277). Among the other general symptoms and pathological changes resulting from pantothenic acid deficiency in mice are spinal curvature, serous exudate around the eyes, a kicking twitch of the hind legs (Sandza and Cerecedo, *J. Nutrition*, 1941, 21, 609), myelin degeneration in sciatic nerves and spinal cord accompanying paralysis, hyperkeratotic, atrophic, and desquamative dermatosis and loss of weight in adults (Morris and Lippincott, *J. Nat. Cancer Inst.* 1941, 2, 189). The lack of adrenal injury is notable. Increase of litter size in mice results from an abundant supply of pantothenic acid (Taylor, Pennington, and Thacker, *J. Nutrition*, 1943, 25, 389). The pantothenic acid requirement of mice is approximately 30 pg. per day.

Pantothenic acid deficiency in dogs produces a different picture (Schaefer, McKibbin, and Elvehjem, *J. Biol. Chem.* 1942, 134, 321). Suddenness of failure is outstanding. Often they eat normally up to the day of their death from the deficiency. Mottled and fatty livers, mottled kidneys, haemorrhagic kidneys, gastritis, severe enteritis, and intussusception in the pyloric and lower ileum regions were observed on autopsy. The adrenal glands were mostly normal. The carbohydrate digestion and absorption in dogs was found to be increased by the addition of pantothenic acid to the diet of dogs already receiving a good diet (Russell and Nasset, *J. Nutrition*, 1941, 22, 287). The pantothenic acid requirement of young puppies is estimated to be about 100 µg. per kilo of body weight per day.

For hogs, pantothenic acid deficiency causes slow growth of young, rough dry coat, emaciation, loss of hair, congested, haemorrhagic, and ulcerated areas in the stomach and large intestine particularly, and a peculiar lack of co-ordination which results in "goose stepping" with the hind legs (Hughes and Ittner, *J. Animal Sci.* 1942, 1, 116). Gastrointestinal symptoms are prominent in dogs. Growing pigs are thought to



require about 10 mg. daily for each 100 lb. weight.

Normal human beings excrete something  $> 3$  mg; (T pantothenic acid per day and their requirements are estimated to be about 10 mg. per day. Clear examples of uncomplicated pantothenic acid deficiency in human beings have never been observed or produced. Human experiments have indicated that pantothenic acid administration may be effective in some cases of peripheral neuritis, Korsakoff's syndrome, and delirium tremens (Williams, 44v. *Enzymology*, 1943, m, 253). Its effects on greying of hair in humans has not been extensively studied and some contradictory results have been obtained.

Pantothenic acid deficiency affects all tissues and organs; in different animals the results of deficiency are manifest in different ways. The number of tissues visibly affected including all animals is very large and it is obvious that widespread disorders may result from its deficiency.

The fundamental role of pantothenic acid is thought, "from analogy with other vitamins, to involve some enzyme system, the exact nature of which has not been clearly elucidated. There are strong indications, however, that it may be involved in the aerobic metabolism of pyruvic acid (Dorfman, Berkman, and Koser, *J. Biol. Chem.* 1942, 144/393; Teague and Williams? *J. Gen. Physiol.* 1942, 25, 777; Hills, *Biochem. J.* 1943, 37, 418).

*Pharmacology.*—Administration of pantothenic acid to normal animals or human beings is practically without effect. The lethal dose for mice and rats is in terms of grams per kilo of body weight. A 1% solution can be instilled into the conjunctival sac or injected into rabbits without irritation or inflammation. Monkeys fed 1 g. per day were unharmed after six months, and dogs and cats survived unharmed a similar period. Dosages up to about 2,000 times their daily requirement (Unna and Gustin, *J. Pharmacol.* 1941, 73, 85). Human beings failed to respond so far as blood pressure, pulse, temperature or respiration was concerned when 100 mg. was injected (Spies *et al.*, *J. Amer. Med. Assoc.* 1940, 115, 523).

*Derivatives and their Specificity.*—Among the substances structurally related to pantothenic acid, the following have the physiological activity of pantothenic acid when administered to the organisms indicated: hydroxypantothenic acid—limited activity for micro-organisms and rats (Zschiesche and Mitchell, *Proc. Soc. Exp. Biol. Med.* 1940, 45, 565); alkyl pantothenates—ineffective for yeast and bacteria but fully effective for rats (Grüssner, Gatzl-Fichter, and Reictetein, *Helv. Chim. Acta*, 1940, 28, 1276); ethyl monoacetylpantothenate—ineffective for micro-organisms but fully effective for rats and chicks (Unna and Mushett, *Amer. J. Physiol.* 1942, 135, 267); pantothenyl alcohol—ineffective for micro-organisms but fully effective for rats (Pfaltz, *Z. Vitaminforsch.* 1943, 13, 236; *Amer. Chem. Abstr.* 1944, 38, 6339). Pantoyltaurine is antagonistic to pantothenic acid for micro-organisms, but its effect may be overcome by an excess of the vitamin (Snell, *J. Biol. Chem.* 1941, 141, 121).

### Pantoyltaurine

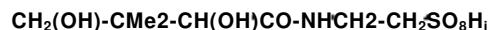

is a sulphur analogue of pantothenic acid. When introduced into the culture media of organisms requiring exogenous pantothenic acid, it acts antagonistically to pantothenic acid and may cause cessation of growth. It is thought to act by blocking out the vitamin, and its effects can in general be overcome by a high concentration of pantothenic acid (Snell, *ibid.* 1941, 139, 975; *ibid.* 1941, 141, 121). *Pantoyltauramide* has a similar but less marked inhibitory effect (McIlwain, *Biochem. J.* 1942, 36, 417).

R. J. W.

**PAPAIN.** This is the name given to the proteolytic enzyme which occurs in the latex of *Carica papaya*. Preparations from this source may contain two separate, but very similar, enzymes, which are sometimes termed papain and chymopapain (Bergmann, Zervas, and Fruton, *J. Biol. Chem.* 1936, 115, 593; Bergmann, Fruton, and Fraenkel-Conrat, *ibid.* 1937, 119, 35). Both the enzymes have been obtained crystalline by Balls and his colleagues (*Science*, 1937, 86, 379; *J. Biol. Chem.* 1939, 180, 669; 1941, 137, 459).

The isoelectric point of papain is pH 9 and its molecular weight (from osmotic pressure measurements) about 27,000. The type of proteolytic activity it displays is similar to that of trypsin, and it attacks most proteins, proteoses, and peptones. Its activity can be measured by milk clotting, hemoglobin hydrolysis, or by the hydrolysis of hippurylamide (Balls and Lineweaver, *ibid.* 1939, 180, 669).

H. G. B.

**PAPERMAKING.** The term "Paper" is correctly applied only to sheet materials made by felting together the vegetable cellulose fibres which are contained in almost all plant materials. The first stage of papermaking therefore consists in isolating the cellulose fibres from the other constituents of the living plant and in purifying and bleaching them. In cotton, fine long fibres of nearly pure cellulose grow on the outside of the cotton seed husks and form the simplest source of the material from which paper may be made. The longer of these fibres which can be pulled off free from husk are so easily spun and woven into cotton cloth that they are too valuable to be used for paper. When however the cotton cloth has been used for clothes or curtains until worn out the rags are collected and make excellent material for fine paper. Actually, paper was first made from cotton rags when the Chinese endeavoured to find something cheaper than silk on which to paint their letters. They discovered that rags could be pounded down to a suspension of short cotton fibres by beating the rags in water, and that when the water was drained away from a thin layer of such a suspension the remaining mat of felted fibres when dried held together as quite a strong sheet.

It was soon found that this cohesion of the felted fibres to one another when the mat was dried was the property of cellulose fibres alone and not shared by wool or silk or hairs.

It is now known that it is not shared by any

artificial fibres even when these are composed of cellulose. It is a property of every naturally occurring cellulose fibre when separated from the materials in which it is embedded in the plant, though, naturally, due to differences in size, shape, and chemical quality of the cellulose, the fibres of some plants make much better paper than others.

The cellulose fibres in any plant are distinct entities of a length and width approximately equal throughout any one plant, though some plants show at least two types of fibre. The dimensions of these fibres vary enormously from one species to another. The fibres are embedded in the plant in a very undefined material called lignin. Associated with this lignin are Carbohydrates, pectins, and small quantities of metallic salts, all of which must be substantially removed to free the cellulose fibres for paper-making. As long as any considerable proportion of ligneous material is adhering to the fibre surfaces these will not bind together strongly when the mat of felted fibres is dried, and no strong paper can be made. In order to make paper of anything other than cotton rags a method must first be devised to free the cellulose fibres from the encrusting materials. The first method of this kind was invented not for papermaking but to obtain flax fibres for spinning and weaving into linen and consists simply in leaving the flax stalks in water until the encrusting materials are so softened by rotting that they can be scraped away from the flax fibres. When papermaking spread from the East to Europe, linen was more common than the cotton the Chinese used. These were received as 'dirty rags' and were boiled to remove the dirt; potashes, later washing soda and then caustic soda were used in the boil to help the cleansing. With the coming of steam engines and pressure steam this boiling of dirty or coloured rags began to be carried out in rotating steam heated boilers under pressure. Thus when the demand for paper began to exceed the supply of rags there was both the apparatus and the skill available to enable the effect of a caustic boil to be tried on materials other than rags.

Among the materials first used in this way were straw and wood. With straw, considerable success was achieved, since by boiling long enough with a sufficiently strong, caustic liquor all but the cellulose fibres dissolved and could be washed away, after which the remaining fibres could be bleached. Some quite good samples of straw paper nearly 100 years old are still in existence. With the steam pressures then available no success was obtained with wood, but since wood is plentiful and easier to transport than straw, efforts went on vigorously to find a method of getting a pulp of cellulose fibres from wood.

When higher steam pressures became available it was found that at 100 lb. per sq. in. wood could be boiled to a pulp by caustic soda. This soon led to the discovery that spruce wood gave better fibres for paper than any other. Caustic soda is not very cheap and it was discovered that it could be replaced by the much cheaper sodium sulphate. When the liquor from such a boil is concentrated and the residue roasted, sodium

sulphide is formed. This is dissolved and re-used along with some fresh sulphate so that the boil is actually carried out in a mixture of sulphide and sulphate. Many efforts were made to find an acid method of pulping wood, and eventually it was found that sulphurous acid mixed with more or less sodium or calcium sulphite would dissolve the lignin at high temperatures without attacking the cellulose. This was very fortunate, since sulphurous acid is cheaply made by burning sulphur or iron pyrites and dissolving the sulphur dioxide formed in water. In this way the sulphite process, by which most of the paper pulp in the world is now made, was developed.

Alongside this development of methods of pulping wood the search went on for other plants which would yield good paper pulps. The outstanding discovery was the esparto plant, a plant growing in clumps of tough grass-like shoots some 2 ft. long on the sand dunes of the Mediterranean coast, particularly in North Africa. This boils in caustic more easily than straw to give a pulp easy to bleach and yielding a paper of peculiar excellency for high-grade printing. This material was developed rapidly for paper-making in the British Isles, particularly in Scotland. It could be imported cheaply as a return cargo for boats carrying British coal to Italy. The excellence of this plant led to the complete neglect of straw, which is the only papermaking raw material which grows in sufficient quantity in Great Britain to make any appreciable contribution to British paper needs. Conditions were thus made very difficult for this country during the early days of the 1939-45 war, when all supplies of esparto and all usual sources of wood pulp were cut off. However, before the end of the war the papermakers devised methods for pulping straw which would make it possible to build large straw-pulp mills sufficient to ensure vital paper supplies in any future emergency, and also to satisfy as much of the nation's needs as possible from home-grown material.

A brief description follows of the four main processes of producing pulp for papermaking referred to above:

1. The preparation of rag pulp from rags.
2. The preparation of esparto and straw pulp by boiling in caustic."
3. The sulphate wood-pulp process.
4. The sulphite wood-pulp process.

#### The Preparation of Rag Pulp.

Although rag merchants sort into grades the rags they sell this is not done carefully enough for fine-paper manufacturers, and the first step in the process is to sort the rags, removing buttons and any metal pieces, elastic or anything containing rubber, and all pieces of silt or wool or of any artificial fibre, if the best papers are to be made. For lower grades, pieces containing cotton or linen with a percentage of artificial fibre are sometimes used but the artificial fibres contribute nothing to the paper strength and are in fact merely loading material. After sorting, the rags are cut in a rotary cutter into pieces 2 or 3 ins. square. In some mills this is still done by hand either wholly or in part during the sorting process. After cutting, the rags are dusted

by passing down a rotating cylinder covered with, a wire gauze through which the Must falls. After dusting; the rags are boiled in slowly rotating spherical or cylindrical elcol boilers capable of holding from 1 to 3 tons of rags. The boiling liquor is always alkaline, being either caustic soda, sodium carbonate, lime, or lime and sodium carbonate mixed. Occasionally, a little sodium silicate or clay is also added to help to remove grease, and, recently, emulsifying agents have

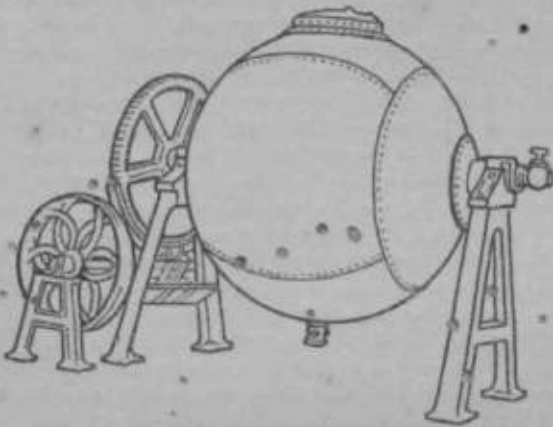

Flo. 1"—SPHERICAL RAG-BOILER.

been mod. The ratio of water to rags varies from 3:1 to 4:1 and the ratio of alkali to rags varies enormously from 1% to about 15% according to the amount of dirt, colour, or sizing materials which have to be removed. The steam pressure used varies from 5 lb. up to about 50 lb. per sq. in., and the time of boiling from 2 to 14 hours.

This boiling produces no important chemical or physical change in the cotton or linen fibres of which the rags are made but is designed merely

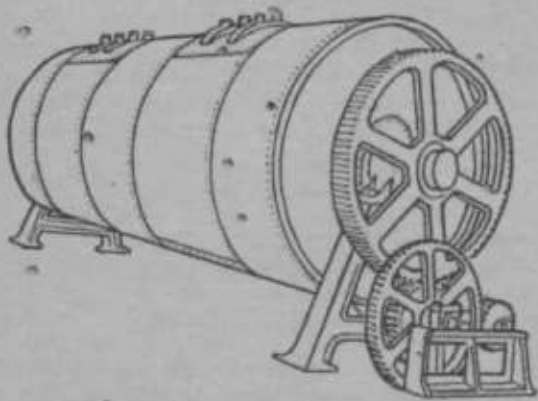

Km. 11.—CYLINDRICAL RAG-BOILER.

to remove or dissolve any noncellulosic materials present.

After boiling, the liquor is drained off and in some cases the alkali is recovered. The rags are rinsed in the boiler, sometimes with hot water, and from the bottom upwards to float and wash away melted grease. The rags, which are still in the piece, are strained and let out of the boiler into boxes for removal to the next stage, which is breaking-in and washing. These processes are carried out simultaneously in a rectangular trough-shaped vessel in which the rags are placed

with about 20 times the weight of water and propelled by a roll bearing bar and dipping half into the trough and rotating a short distance above a bedplate with similar bars.

The squeezing and bruising of the rag pieces between the bars on the roll and bedplate as they are moved round the trough by the rotating roll slowly disintegrates the pieces into threads and finally into the fibres from which the threads were spun at the same time loosening any dirt which was enmeshed in the rag structure. While this breaking-in process is going on, a stream of clean water is run continuously into the trough and removed by a cylindrical rotating drum covered with a wire gauze covering and fitted inside with scoops which remove the water through the axle on which the drum rotates. In this way a pulp of clean freely dispersed cotton or linen fibres is produced. This has then to be bleached white if it is to be used for fine papers.

### The Preparation of Esparto and Straw Pulp.

For pulping these materials caustic soda is the only alkali used, except when making cheap straw-board, when lime is often used. The process is not mainly a cleaning process, as with rags, but is a chemical disintegration of the whole structure of the esparto or straw stalks by dissolving out the material, mainly lignin, in which the cellulose fibres of the plant are embedded, so netting the cellulose fibres free. The ratio of liquor to esparto or straw is usually 3:1 to 4:1, as with rags, but the ratio of caustic to fibre is more, being 12-15% for esparto and 18-25% for straw. The time of boiling is about 5 hours at 45 lb. per sq. in. for esparto and 7-8 hours at 75-80 lb. per sq. in. for straw. The yield of cellulose fibres left undissolved at the end of the boiling is 42-44% for esparto and about 33% for straw.

The facts that straw needs more caustic and gives a considerably lower yield than esparto, while the steam pressure and time taken are both higher explain why straw is not used as long as esparto is available.

The caustic soda used is too expensive to be allowed to run to waste. It is drained away as completely as possible and the pulp in the boiler washed once with water. The caustic liquor, usually known as "black liquor," due to its very dark colour, and the first wash water are concentrated to a thick treacle-like consistency, when it can be dried continuously in a rotating cylindrical roaster by the heat of combustion of previously dried black liquor. This roaster is slightly inclined; the concentrated black liquor enters at the upper end where the hot gases are drawn off to a chimney and almost completely incinerated soda ash falls out at the lower end. This is allowed to fall into a tank of water, where it yields a solution of sodium carbonate and a precipitate of carbon black, which can be filtered out. The sodium carbonate is recastirised with lime, and the caustic liquor re-used. The precipitated calcium carbonate is filtered off, washed free from alkali and used for liming agricultural land. With esparto, some 80-85%

of the caustic used may be recovered by these means, but straw pulp is so much harder to drain and wash that in most cases 46-50% is all that can be recovered. This is another reason why esparto is preferred to straw, and if straw is ever to be pulped on a large scale in this country a means of greatly improving the low soda recovery will have to be found.

The boilers in which esparto or straw are boiled are cylindrical steel vessels 10-14 ft. high and 9-10 ft. in diameter. They are fitted with a perforated steel drainer plate placed just where the cylinder begins to bend inwards to form the bottom. There are either several vomit pipes fitted just inside the boiler wall to allow the steam which is let in at the centre of the bottom

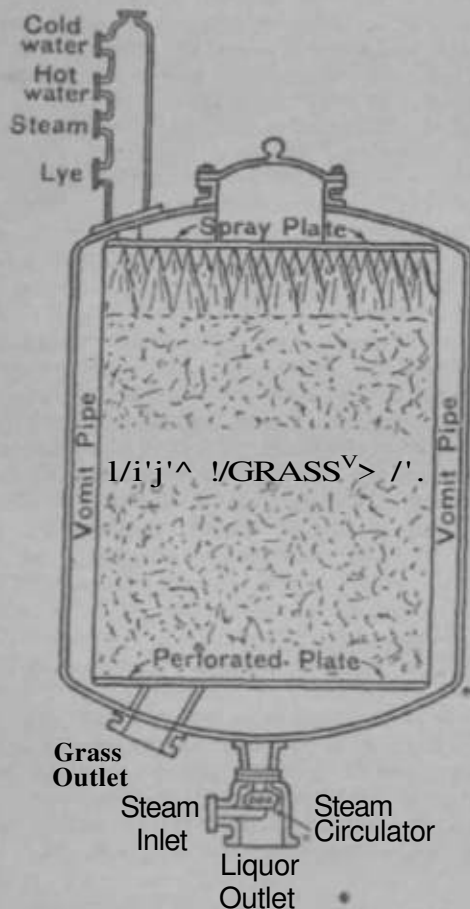

Fig. 3.—ESPARTO BOILER.

of the cylinder to circulate the liquor during the boil, or the circulation may be effected by the use of an outside pipe leading from the bottom of the boiler through a centrifugal pump into a distributing pipe inside the upper end of the cylinder. The boiler is fitted with a large circular lid in the top which is removed for tilling the boiler and then screwed on before the boiler is tilled. The lid has a steam cock through which air is expelled when the boiler starts. In boilers with vomit pipes, and no external circulation to ensure a sufficient difference of pressure between the top and the bottom to insure the desired circulation, the lid is usually allowed to let out a little steam during the boil.

When the boil is over, and the black liquor and a first wash have been drained away to soda

recovery, a hole in the middle of the bottom drainer plate is uncovered and the whole contents of the boiler blown through by a stream of high-pressure water, delivered through an iron pipe and nozzle suspended through the lid of the boiler. The boiler is connected with a pipe passing through a centrifugal pump, and on to potchers, in which final washing and bleaching take place.

A few mills have a slightly more modern type of boiler which has a tapering conical bottom end; it is lined inside with a perforated plate a few inches from this tapering wall. The tapering perforated plate and the outer wall both end in a fairly large vent hole tightly closed while the boiler is in progress. Circulation takes place through the perforated plate, liquor being withdrawn from the space between it and the outer wall and pumped up to the top of the boiler. In a boiler of this type the cover over the vent hole is removed when the boiler is over before the pressure is altogether allowed, and pulp and liquor are blown out of the boiler very quickly. This system allows of a much quicker cycle of operations, and ensures more boils per boiler per week.

The pulp from the boiler needs straining to remove incompletely disintegrated portions, and to be passed over sandtables to remove odd pieces of stone or other contraries which may have contaminated the original raw material. This is sometimes done before, sometimes after teaching, and occasionally both before and after this operation. In any case the pulp must be washed free from alkali and the dark stain produced in the boiler; the bleaching is always done by simply adding ordinary bleaching powder solution. After warming, the pulp being washed again to remove the products of bleach action. The washed, bleached, strained pulp is then concentrated to about 20% solids content and is then ready for the beaters.

### The Sulphate Process for Wood Pulps.

This process is used only on wood, which is almost always of the coniferous type. Since the cooking liquid is alkaline, it dissolves out the resins and fatty acids, so that very resinous woods can be successfully pulped. The acid sulphite process does not remove the wood resins and if the wood pulped contains much resin this remains in the pulp and causes great inconvenience in subsequent papermaking. Thus it is that, though some spruce is used in the sulphate process, this is mostly left for the sulphite process, and highly resinous woods like Jack Pine and Yellow Pine are treated by the former process.

The sulphate process is cheaper than the soda process, which is not now used for pulping the long-fibered coniferous wood; this needs so much alkali for pulping that, using caustic alone, the cellulose is attacked while the lignin is being dissolved and a rather weak pulp results.

In the sulphate process the only make-up material is sodium sulphate. Some canst is must be mixed with it to get the process started just thereafter when the liquor is dried down to black ash and the black ash smelted the carbon set free from the organic materials reduces some

of the sulphate to sulphide, and also leaves all the sodium, which in the black liquor was combined with organic material, dissolved out of the wood as sodium carbonate. When the smelted black ash is dissolved in water the content of carbonate is determined and lime added to recausticise it. When the precipitated calcium carbonate has been filtered off a white liquor containing a mixture of caustic soda, sodium sulphide, and some sodium sulphate is left with which to continue the boils. By continually adding the necessary quantity of sodium sulphate to make up the unavoidable losses in the process the composition of the white liquor is kept substantially constant, some sodium carbonate being produced and recausticised each round.

This mixed solution is milder in its action on wood than caustic soda. The dissolving out of the lignin is never taken to completion and the pulps so produced are very difficult to bleach, it being impossible to make them white by bleach solution alone, however much is used. They give, however, very strong papers and have therefore earned the name of "Kraft" pulps (from the Swedish word for "strong"). Most wrapping papers are made from such pulps, and since these are acceptable in a brown colour their preparation from unbleachable material is no disadvantage. By using a two or three stage bleaching process, one stage being a chlorination, white pulps can be obtained without loss of strength.

The sulphate process is carried out in upright iron boilers similar to those used for esparto but usually larger, taking up to 10 tons, and generally with eternal forced circulation. The pressure used is higher than that needed for esparto, being, usually 100-130 lb. per sq. in. The logs used are first barked and then chopped up into chips about three-quarters of an inch long. The time of boil is usually about 4 hours of which 1½ hours is occupied by steaming the wood and rising gradually to the maximum temperature and pressure, but the time varies considerably from mill to mill.

### The Sulphite Process.

Many attempts have been made from time to time to pulp wood by means of acids, but the only really successful commercial acid process is the one using sulphurous acid; this was discovered and patented by B. C. and R. Tilghman of America and made a commercial success by the Swedish chemist C. D. Ekman.

At a moderately high temperature and pressure sulphurous acid will combine with the lignin in wood to produce a water soluble sulphonic acid derivative without appreciably in any way affecting the cellulose fibres. While sulphurous acid alone will pulp wood the volume of solution needed is inconveniently large. For this reason solutions of metallic bisulphites containing excess of sulphur dioxide are always used. Although sodium bisulphite can be, and occasionally is, used, calcium or magnesium bisulphites on the score of cheapness are the salts almost universally employed.

The sulphur dioxide is made by burning either

sulphur or iron pyrites in specially designed furnaces, care being taken to conduct the burning carefully at as low a temperature as possible to minimise the production of sulphur trioxide. The gas formed is cooled as rapidly as possible to below the temperature at which it will combine with oxygen to produce sulphur trioxide. The cooled gas is then led up towers containing limestone over which water is allowed to trickle. The sulphurous acid formed in the water dissolves the limestone to give, when enough sulphur dioxide has passed, a solution of calcium and magnesium bisulphite containing excess of sulphur dioxide. Since, during the boil, a good deal of sulphur dioxide is given off, the acid liquor is not taken to full strength in the towers but is treated with sulphur dioxide obtained from the boilers to bring it finally to the desired strength, and also to recover the sulphur dioxide given off. The acid liquor shows considerable variation. In particular the ratio of calcium to magnesium will vary according to the limestone used. In general the liquor has a total sulphur dioxide content of 2-8-3-0% of which 0-9-1-2% will be combined as acid sulphite, the rest being free in solution.

Sulphite boils are carried out on wood chips from barked logs, as in the sulphate process. The digestors are larger, holding 12-18 tons; they are tall steel cylindrical shells tapered at both ends and lined inside with acid resisting bricks set in acid resistant cement.

There are two main methods of cooking: (i) The Ritter-Kellner, in which rapid heating is obtained by blowing live steam directly into the boiler. The boil is for 8-10 hours at about 140-145°C. though sometimes 155-160°C. is used, (ii) The Mitscherlich indirect heating method. Here the steam passes through copper or lead coils in the boiler; the heating is slower and less intense, usually only reaching 125-135°C. This means a much longer boiling-time of from 2-30 hours or even more. This difference in boiling procedure makes a very appreciable difference in the papermaking quality of the pulp produced. The fast high temperature boils yield pulps which are weaker and harder to wet up in the beater. The long low temperature boils yield strong easily wetted pulps.

### THE CONVERSION OF PULP TO PAPER.

For the preparation of fine papers the cellulose fibre-pulp, prepared by one or other of the above methods, is bleached to a good white colour. For wrapping papers, or papers for many industrial purposes, such as resin impregnation, this step can be dispensed with, but for all printing, drawing, writing, cheque, ledger, or map and chart papers, a good white colour is essential.

For rag, straw, and esparto pulps, direct single-stage bleaching with ordinary bleaching powder solution is almost always employed. In the wood-pulp mills, however, especially when a strong white pulp is aimed at, the bleaching is done in several stages, one of which is a chlorination with gaseous chlorine or acidified bleach followed by an alkaline wash to remove the



alkali soluble chlorinated-lignin compounds produced.

The difficulty is to remove the coloring matters without attacking the cellulose. Neutral bleach oxidises cellulose very quickly, so that either acid or alkaline bleach or chlorine water must be used. Alkaline bleach has oxidising properties and if used in sufficient quantity and at a sufficient concentration will bleach most coloring matters white, but if any of the harder-to-bleach coloring matters are present considerable attack on the cellulose will take place during the process. Acid bleach or chlorine water chlorinate the lignin or coloring matter, and the product is often insoluble in water, or itself coloured. Such compounds usually dissolve in caustic or in sodium sulphite solution. Acid bleach or chlorine does not attack cellulose so by using them and then extracting the chlorinated compounds with caustic or sodium sulphite much of the lignin and coloring matter can be removed without attacking the cellulose. With some materials like esparto and straw this process of chlorination and alkaline wash can be employed after a very mild caustic boil which leaves most of the lignin still present. This is the basis of the well-known Pomilio straw-pulping method. The straw is chopped, dusted, and then given a very mild caustic boil. It is then washed, pressed fairly dry, and broken up and subsequently treated with chlorine gas; this chlorinates the lignin, liberating heat and hydrochloric acid. Since the pulp is only damp with water, the acid solution becomes concentrated and it is difficult to control the chlorination so that no damage is done to the cellulose fibres.

After an alkaline wash and a mild alkaline bleach treatment a white pulp results. With wood the preliminary boil cannot be cut down nearly as far as with straw but, nevertheless, if the boil is cut down so far as to leave a pulp unbleachable by a single-stage direct bleaching process, the strong pulp so produced can be bleached white, without loss of strength, by a process consisting of chlorination, alkaline wash, and then direct bleaching.

After bleaching and washing it is best to pass the pulp directly over to the preparatory plant to make it ready for the papermaking machine. With rags, esparto, and straw *in situ* is always done; the paper mills using these raw materials have their own pulp-producing plant, but, since wood is not usually obtainable in large quantity in places where it is convenient to make paper, wood-pulp mills normally dry off most of their pulp in board form for export to paper mills, often hundreds of miles away. The effect of this drying out on the papermaking quality of the pulp is such that for some purposes it is preferable to pay the carriage on a large percentage of moisture rather than allow the thing to take place. The fibres lose strength and flexibility when dried and it needs prolonged and careful after-treatment in water to bring them back approximately to their original condition. It is one of the great handicaps to papermaking in this country that we produce no wood suitable for pulping and that all our wood pulp has to be imported, mostly in the dry condition.

The pulp now ready to be prepared for papermaking is treated in apparatus known as breakers and beaters, or, in some modern mills, refiners. The breaker-beater combination was developed in rag-paper mills a long time ago. The boiled and washed rag pieces must be broken up before they can be finally washed and bleached. This process has been described in the rag-boiling section above. After breaking up into the fibres from which the rags were initially spun, and bleaching and thorough washing, the pulp is let down into the beater. This also, like the breaker, is an oval shaped trough

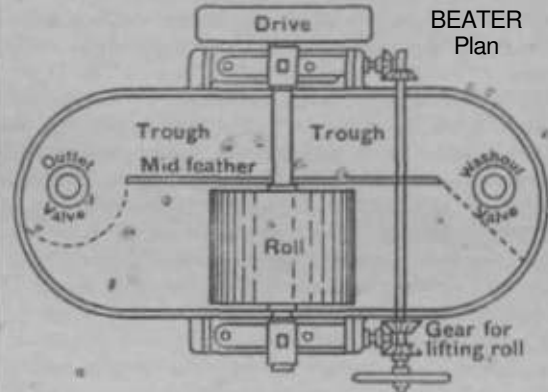

FIG. 4.

with a roll and bed plate both carrying iron or bronze bars. As the roll is revolved the pulp is drawn between the bars on the roll and on the bed plate and is squeezed, crushed, and partly cut or broken up. As the pulp goes around the oval trough, each time it goes under the roll the fibres are cut and crushed until they are as the papermaker requires them for his purpose. As the fibres become shorter, they will fit together into a closer denser sheet but, apart altogether from the shortening, the eluding, and squeezing alters the fibre surface. This consists partly in

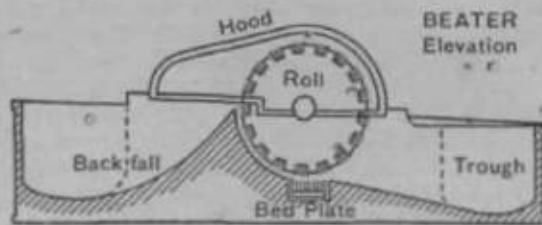

FIG. 5.

the freeing of very fine fibrils which stand out from the fibre surface but, in addition, the colloidal nature of the fibre surface is altered and becomes swollen and gelatinous. When the sheet of paper is formed from such fibres where such gelatinous surfaces are dried in contact with one another, a strong bond is formed between them, probably by some form of cross linkage between them in which the hydroxyl groups of adjacent fibres take part and possibly also a molecule of water. These bonds are quite strong as long as the sheet is dry but, on wetting, water enters and frees the fibres from each other. The more mechanical treatment applied to the pulp the more of these bonds are formed and the stronger they are, provided that

in producing the required colloidal change the fibres are not too much cut up. The change which is produced in this way by beating also slows up the rate at which the pulp loses water when drained on a wire mesh, as on a paper machine, so that a much beaten pulp must be run slower along the wire on the machine, or else it comes off the wire wetter than a less beaten pulp. Thus the papermaker speaks of wet-beaten pulp, and describes the change produced by beating as Wetness.

As may easily be imagined, different fibres react to this beating treatment very differently. Some are brittle and break up quickly with little colloidal change and make close, weak papers. Some produce the colloidal change rapidly with very little shortening of the fibres and, like linen, make strong translucent papers. The reaction of the fibre to beating can be greatly modified by the extent to which it has been boiled and bleached, and the art of papermaking consists in a proper application of that knowledge to produce the end result desired. The most important part of papermaking is what is done to the pulp in the beater.

It will perhaps be realised how that with all the variation in fibre length, degree of fibrillation, and colloidal change of fibre surface which a papermaker can produce by altering the treatment he gives the pulp in the beating operation, and with these effects varying greatly with both the nature of the boiling and bleaching treatment of the pulp being used, how impossible it is to give any precise description of the papermaking process. It is still mainly a craft learned by long experience and which cannot yet be reduced to precise terms.

While the beating process is taking place the pulp is coloured as desired by the addition of dyes or pigments. Also in the beater are added loading materials which it is desired the paper should contain, like clay which alters the feel and the smoothness of the sheet, or titanium dioxide which whitens the sheet and greatly increases its opacity. Some part of such additions are lost with the water which drains away when the sheet is made on the wire of the paper machine, and the percentage retention of such loadings is a figure to which papermakers pay considerable attention.

If the paper it is desired to make is required to take ink writing, it has to be made non-absorbent. This is done by a process known as sizing. A very wet beaten pulp makes a paper like greaseproof which, without any added sizing material, is naturally nonabsorbent and can be written on, though the ink sinks in too much for it to be a really pleasing writing surface.

The old time way of making the hand-made absorbent sheets fit to take ink writing was to dip them into a bath of gelatin solution and then hang them up in the air to dry. The film of gelatin formed in the surfaces of the sheet in this way resists ink and makes a good writing surface. The gelatin film has the added advantage of very strengthening the paper and making it much harder to rub up the surface. This old process has therefore persisted, and is likely to persist for a very long time, since it is the ideal way of making strong durable paper for ledgers

and other similar purposes. It is, however, expensive, due to the high price of gelatin, and also because it involves an additional process for the paper after it leaves the papermaking machines.

It was necessary, therefore, to find some process for making the paper so that it would be able to carry ink by the addition of some water-repellant material to the pulp in the beaters. Probably the use by shipbuilders of rosin led to this material being tried. It was found that when partly saponified by alkali, rosin can be emulsified to a very finely divided, nearly white, emulsion in which form it can be readily mixed uniformly with the pulp in a beater. To prevent loss of rosin by the water draining away from the pulp on the wire of the paper machine, the idea was to precipitate it with some acid material. The easiest and cheapest acid material to use was alum, and this was found to work wonderfully well and was adopted universally by papermakers everywhere long before anyone had any adequate idea as to how it worked. Many efforts have been made to find substitutes for the rosin and alum combination without increasing the cost, but so far without any success. The rosin may be completely saponified and thus be added to the pulp as a solution, as in the Delthirna method; it may be emulsified with only a trace of caustic in the presence of a protective colloid, as in the Bewoid process and added to the pulp as a fine emulsion; or it may be any mixture of these two extremes and the end result of the addition will be the same, provided alum is added until a sufficiently acid pH is obtained in the pulp mixture. No other acid substance will produce the same ink resistance in the paper as alum, with the possible exception of thorium sulphate, which is moderately effective. The alum, together with such alkalinity as is present in the rosin size or in the water, produces a precipitate which contains the rosin, alumina, and basic aluminium sulphate. This comes down as a very fine precipitate and at a pH between 4 and 6 adheres to the surfaces of the cellulose fibres. When dry, this fine precipitate is highly water repellent and prevents water being drawn between the fibres of the paper sheet by capillary attraction.

Rosin precipitated by acid does not come down in nearly so finely divided a form, and is not attracted to the fibre surfaces as is the alum complex, and hence does not size effectively. With the pulp then beaten as desired, coloured, loafed, if that is wanted, and sized if a suitable writing paper is required, it is then necessary to get it felted into a uniform sheet or web of the desired thickness and size, and then dried. This was done originally with a hand mould. A wooden rectangular frame, the area of the sheet desired, was covered with a layer of thin reed stalks laid parallel and close together, reaching from end to end of the frame. These reeds were supported every inch or so along their length by being tied to each other by cotton threads reaching from one side of the frame to the other. The frame so covered was then fitted with a removable rim from 6-25-0-5 in. high.

This frame with the rim in place was then dipped into a tub of the prepared pulp and carefully lifted out horizontally. The water from the



pulp kept on the web by the rim drains through the reeds leaving a mat of fibres on the frame. While this draining is taking place the frame is shaken slightly to help to felt the fibres. When the draining stops the rim is lifted off and the frame and mat of fibres laid down, or "couched" as the papermaker says, on to a wet felt slightly bigger than the frame. It is placed upside down 90° that the mat of fibres comes against the wet felt. It is then possible to lift off the frame and leave the mat of fibres on the felt. This mat is then covered with another wet felt and the process repeated until a pile of sheets is accumulated. This pile is then transferred to a press and as much water as possible pressed out. It is then found that the moist sheets left are strong enough to be lifted off the felts and placed on racks or hung up to dry. For centuries, paper was made by this laborious process sheet by sheet, and hand-made paper made by this ancient craft is still made and sold profitably by one or two small English firms. Wires were substituted for reeds at an early date, and wire gauze for papers where the lines produced in the sheets by the parallel wires were not desired.

The modern papermaking machine has merely mechanised and made continuous this ancient method without altering its essential nature. The highly dilute fibre suspension runs out onto an endless belt of wire gauze which moves steadily forward. An endless belt of rubber, about 2 in. square in cross-section, runs along each edge of the moving wire and performs the same function as the rim of the hand mould.

This endless wire belt runs on metal rollers which help to draw water through the wire to drain the web. Near the far end of the wire it runs over boxes from which a pump withdraws water. At the place where the wire runs round a roller to begin its return journey, a felt covered heavy roll, known as a couch roll, presses the web heavily between itself and the roller carrying the wire, and this pressure further debaters and consolidates the sheet, so that it is possible to make it bridge a gap of an inch or two off from the wire to a felt moving forward to pass two press rolls the top one of which is usually granite which further dewater and consolidate the sheet.

Modern paper machines have several (up to four) presses of this kind. In the first press the top side of the paper is directly against the roller, the wire side having the felt between it and the other roller. This tends to produce a certain difference in the formation of the two surfaces. Thus when very even-sided paper is desired, and several presses are available, it is found best to run through some of them in such a way that the other side of the paper is on the felt.

After sufficient pressing, the web passes to drying cylinders. These are large steel cylinders heated by low-pressure steam. These are a little wider than the widest web the machine is designed to make and vary in diameter according to the size of the machine. They are usually arranged in two rows, the upper row being placed over the spaces between, the cylinders in the lower row. The paper passes round the cylinder and is pressed against the hot metal surface by a dry felt. It then passes to the next cylinder in the other row and thus going over

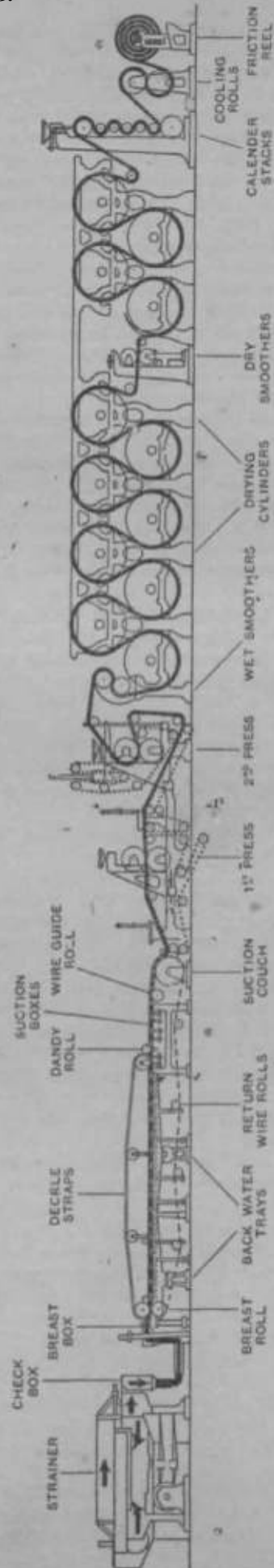

FIG. 6.—PAPER MACHINE.

the top of the cylinders in the top row and under the bottom of the cylinders in the bottom row alternately, it comes at last to the end of the row, when it should be dry. In all modern machines it is smoothed by passing between stacks of calendar rolls before it is finally reeled up.

The earliest machines built about 100 years ago ran very slowly and had only three or four cylinders. A few machines are still running in this country with only six cylinders, but because of the demand for faster running and because slow drying at a low temperature makes the best paper, the number of cylinders tends to be increased every time a new machine is built.

A few paper machines are built with only one very large drying cylinder. This is run without a felt, and the wet web from the presses is pressed by rollers closely onto the hot cylinder surface to which it sticks until it is dry, when it comes away easily with a highly glazed surface on the side which was against the cylinder. In this drying method the paper is unable to shrink at all during drying and this gives to such a paper a greater stability against changes in dimensions in atmospheres of varying humidity than are possessed by papers dried in the usual manner.

There is another process for making paper continuously which although it is never used for fine papers is essential for cardboard and box liners and boards of various kinds. This is the vat machine in which the dilute pulp suspension flows into a large vat containing a partly submerged rotating gauze-covered hollow cylinder roll. Water flows into this cylinder and is removed by suction, leaving a web of fibres on the wire which is lifted out of the vat as the cylinder revolves. After passing a suction box inside the upper portion of the cylinder to further dewater the web, and a couch roll to consolidate it, the web is removed from the cylinder wire. In a vat machine a battery of such vats are operated together and the thin webs from each pass together through presses and over drying cylinders so that a thick board results. It is easy with such a machine to make the centre of the board of rough cheap material and the surface layers of good quality white or coloured paper. On these machines boards can be made so thick that they cannot be rolled up when dry but must be cut into sheets at the end of the machine.

A development from the success of the multiple boards made on these vat machines was to provide two or even three wire sheet-forming sections like those on any ordinary papermaking machine and feeding the sheets made from those wires together through the same presses and drying cylinders together on the same drying cylinders to make duplex or triplex papers, since the endless wire of a paper machine is a large and complicated affair, the fitting of two such wires where the reels are to be fed to the same presses is a very difficult matter. It necessitates one wire being on a floor above the other one, and for three wires, three floors are needed. The particular advantages which justify the expense of such a complicated set-up are firstly the fact that a good printer always detects the difference in surface of the two sides

of a single sheet. However fine the mesh of the wire is, and however carefully the subsequent wet pressing and calendaring is carried out, the wire side always has a slightly different surface from the topside. If the two wires of a duplex machine are properly arranged so that the wire on the lower floor runs the opposite way to that on the top floor, the web from the bottom wire can be turned over as it is led up to meet the web from the top wire, so that the two wire sides come together in the middle of the duplex sheet and the finished sheet is identical on the two sides. The same result can be achieved on a triplex machine and in addition the centre portion need not be of the same quality as the outsides.

The second advantage of duplex and triplex machines is due to the fact that if pulp is beaten wet so as to get the maximum strength in the finished paper it is hard to get the water away on the wire in order to make a heavy sheet. Consequently when thick single sheets are required, less beating can be given and the strength is much less than it might be. Obviously, if three sheets are to be united the pulp for each sheet can be beaten much more than would be possible in making a single sheet of the same substance. Thus the strongest heavy papers are made on multi-wire machines.

When the paper leaves the paper machine it is often far from being ready for use as it is often not possible with the calendar rolls at the end of the paper machine to make the surface as smooth as is desired. In that case the next process is super calendaring. In this process the paper passes through a stack of heavy rollers one above the other. The paper passes over the top roll, between the top and second roll, half round the second roll, between the second and third rolls and so on, right down the stack of perhaps as many as ten rolls. Obviously, the pressure exerted on the paper increases at each nip till the last one is reached. These rolls may be all steel or some may be steel and some coated with a deep layer of compressed cotton, or all the rolls may be cotton covered. Extra weights may be hung on the rolls to increase the pressure beyond that caused by their own weight. In this way the paper is compressed and surface irregularities smoothed out until a surface of the desired smoothness is reached.

Another defect in paper directly off the paper machine is that it is always too dry. At the relative humidity of about 65-70%, which is about the average for Great Britain, cellulose or paper normally absorbs about 7% of moisture. Because drying is never even over the whole width of a reel in even the best of paper machines, attempts to bring the paper off with an average of 7% of moisture result in the moisture content being uneven. To lessen this unevenness the paper is overdried to 3 or 4% moisture. Then in a normal atmosphere it rapidly picks up moisture to about 7% at all the surfaces to which the moist air has access and the paper expands appreciably. Thus if paper at 3% moisture content is cut into sheets and rapidly stacked in piles the edges will absorb moisture and expand but the middle of the sheets will remain dry. This causes the edges to cockle

badly. Thus the overdrying of the paper necessitates a subsequent careful humidification to about 7% moisture content before it is cut into sheets and stacked or bound into ream packets. This is done by passing the paper slowly over a long series of spar drums rotating in a damp atmosphere until it has absorbed the required amount of moisture. This procedure ensures an even distribution of moisture throughout the web, since no part will pick up from a damp atmosphere more moisture than the equilibrium content at that relative humidity. The process of slow humidification has another great advantage. The drying on the Lqt cylinders of the paper machine puts considerably strains into the paper which are not relieved under the tension of the paper machine or when tightly reeled up. During the slow passage down the humidifier, however, these strains can be relieved and when the paper is cut it will be flat instead of curling up at the edges, or even rolling up into a tube as unhumidified paper does sometimes.

After humidification the paper is cut into sheets by unrolling the web off the reel onto a flat surface on which vortical circular knives run, spaced apart, so that the web is cut into strips having as their width one of the dimensions of the desired sheets. These strips then pass under straight knife edges set on a rotating cylinder so that they come down and chop off pieces of the strips having a length equal to the other dimension of the required sheets. The sheets are then collected into piles.

It is not possible by this rapid continuous cutting from the reel into sheets to get very exact dimensions in the sheets. If sheets of very exact size are required they are cut into somewhat bigger sheets by the method described above, and then the pile so produced is trimmed down to the exact size wanted by a very carefully made instrument called a guillotine. This machine has a fiat table, on which the pile of sheets is placed, and three accurately squared straight edges which can be adjusted to any desired distance apart. The fourth edge of the rectangle is occupied by a rigid knife edge which can be adjusted accurately to any desired distance from the back straight edge. By pushing the pile of sheets against the back straight edge, setting the knife to the right distance and then letting it be forced down to trim the edge under the knife, and repeating the operation till all four sides are trimmed, a pile of sheets of exactly the size required can be obtained.

Naturally, only fine paper requires such an accurate size as to justify the cost of the guillotine treatment, but even after this treatment the paper is not ready to send out. It is impossible in papermaking to prevent occasional creases and tears occurring in the web and even the greatest care cannot prevent an occasional spot of dirt or unwanted material getting in. Therefore before the paper goes out every sheet must be inspected and any showing the slightest imperfection removed. This is skilled hand work and is always done by women. They inspect each sheet, and afterwards count every sheet passed and mark with a slip of paper, projecting from the pile of counted sheets, each time

the number required for a ream, usually 500 these days, is reached. The paper is then packed, each 500 sheets in a separate ream packet, duly labelled and packed in crates, boxes, or railway containers for transport to the customer.

Nothing has been said in detail so far about the ancient process of tubsizing for making hand-made sheets of cotton or linen fibres so that they could be written on with ink without the ink sinking through the paper or feathering along the edges of the pen strokes. The process was to 'Up the sheets into a bath of gelatin solution, remove excess of the solution by passing the wet sheet between the rollers of a wringer and then hanging them up to dry in the air. The surface gelatin film so produced rendered the paper resistant to ink. It also greatly increased the strength and, particularly, the folding endurance of the paper.

Although the discovery that sizing by adding rosin and alum to the pulp before sheet-making is cheaper and eliminates the need for an extra process, it has never been able to oust from use the ancient process of gelatin tubsizing for all the high grade rag-papers. The process is an extra one carried out on the reels or paper which come from the end of the papermaking machine. It is usual to reel up the paper at the end of the paper machine and to remove it to a separate tubsizer where it is unreeled through a bath of warm gelatin solution. In a few old rag-paper mills the paper is led directly from the end of the paper machine through the gelatin solution. In proper tubsizing a long bath is used to give plenty of time for the gelatin to penetrate into the paper. The paper passes two or three times under a roll below the surface of the gelatin and then over a roll above the surface of the gelatin before reaching the nip rolls at the end of the bath which remove excess gelatin from the surface. The nip rollers are followed by spar drums arranged in two long layers. The paper travels alternately over one of the top layer of drums and below the next drum in the lower layer until the end of the drums is reached. There may be 40 or more spar drums in one of these air-drier sections. Warm dry air passes up through these spar drums to dry the paper. This careful low-tempo air-drying is necessary to preserve the gelatin film in its strongest and most complete form. For some purposes, however, this gelatin film is too impervious and it is an advantage to break it up somewhat by drying on hot cylinders. This prevents the maximum strength being produced which gelatin can give, but nevertheless quite a good increase in strength is obtained in these, hot-dried gelatin-sized papers and the paper still preserves much of the surface properties and feel of a properly tubsized paper.

Since the discovery of rosin sizing and due to the necessity of passing reels of paper through long size-vats instead of the old simple dipping of small single sheets, it is found that entirely unsized cotton paper weakens so quickly in a bath of warm gelatin that it cannot be pulled through a gelatin-size bath. This difficulty is obviated by adding rosin size in the preliminary papermaking operation. The softening of the sheet then takes place much more slowly,

and the {Taper can be carried through the vat and onto the air-drier before it is softened enough to break.

The' fact that for some purposes hot drying after tubsizing is no disadvantage opens up the possibility of doing tubsizing on the paper machine without the need of a very long and cumbersome air-drier. Quite a few modern paper machines are fitted with a short tubsize vat near the end of the machine. This vat is followed by nip rolls and three or four spar drums to enable the gelatin to sink into the paper surface before coming onto the remaining few drying cylinders of the paper machine. On such a machine tubsized paper with a near approach to the proper tubsized quality can be made in one operation at ordinary paper-machine speeds.\* The gelatin film, however, is broken and driven into the paper, so that for the best papers the full tubsizing and air flrjing as a separate process is still alwatfc employed.

PARABANIC ACID, *HiN'. Oxalyluric acid*,  
2Ais-Triketoimidazolidine,

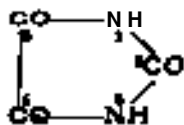

Parabanic acid was first characterised by oxidation of uric acid with nitric acid (Liebig and Wohler, *Annalen*, 1838, 26, 285), being obtained in 33% yield (Behrend and Asche, *ibid.* 1918, 416 226). It has been obtained by oxidation of uric acid <^fjh bromine water, potassium chlorate, and hydrochloric acid (similarly from guanine), manganese dioxide and Sot dilute sulphuric acid, by\* electrolytic oxidation, and in 80% yield using hydrogen peroxide (Biltz and Schiemann, *Ber.* 1926, 69 [B], 721).

3t has been obtained synthetically from oxamide by heating with dipheny? carbonate at 240-250° (Cazeneuve, *Compt. rend.* 1899, 129, 834) or phosgene at 170-180° (Basarow, *Ber.* 1872, 5? 477); by the action of phosphorus oxychloride on a mixture of oxalic acid and urea, or on oxaluric acid (Grimaux, *Compt. rend.*\*1873, 77, 1548); from idea and ethyl oxalate in presence of alcoholic sodium ethoxide (Michael, *J.-pr Ohem.* 1887, [ii], 85, 457), or urea and oxalyl chloride (Bornwater, *Rec. trav. chim.* 1912, 31, 105; Biltz and Topp, *Ber.* 1913, 46, 1387).

It crystallises from water in monoclinic prisms, m.p. 242^244° (decomp.),,l part dissolving in 21-2 parts of water at 8°. Easily soluble 2Q warm alcohol; insoluble in ether. Dissociation constant i\* water at 25°, 7.5 x10^11^7 (Wood, *J.O.S.* 1906, 89, 1835). Absorbs continuously in ultra-violet light.

Parabanic acid behaves as a dibasic acid, the crystalline alkaline metal salts decomposing to those of oxaluric acid in hot aqueous solution (Menschutkin, *Annalen*, 1874, 172, 75); *urea* \*<to, C<sub>2</sub>H<sub>2</sub>O<sub>3</sub>N<sub>2</sub>, CH<sub>4</sub>ON<sub>2</sub>, forms rhombs or plates (Hlasiwetz, *J. pr. Chem.* 1856, [i], 69, 106); *phenylhydrazine salt*,



yields oxaluric phenylhydrazide in hot water (Skinner and Ruhemann, *J.G.S.* 1888, 53, 556).

Heating with alcoholic ammonia at 100° yields oxaluric amide (Menschutkin *I.e.*), hydrazine the corresponding hydrazide (Fosse, de Graeve, and Thomas, *Compt. rend.* 1935, 200, 1260) and aniline the anilide (Laurent and Gerhardt, *Annalen*, 1848, 68, 25). The product obtained by reaction with urea (Grimaux, *Bull. Soc. chim.*, 1879, [ii], 32, 120) was probably a mixture of oxalyl diureide and hydroxy-allantoin (Pinguet, *Compt. rind.* 1933, 196, 112). Reaction with hydantoin, v. HYDANTOIN.

.-/ R. B.

PARACHOR. Introduction.—The parachor is an empirical constant for a liquid which may be regarded as a corrected molecular volume. It is based upon a relation between surface tension and density given by the equation

$$y = C (D \cdot d)^* \dots \dots (1)$$

Here y is the surface tension of a liquid, D its density, and d the density of the vapour, all at the same temperature; the constant O is then found to have a fixed vuluo for a particular liquid over a wide range. of temperatures. This formula was discovered by Kleeman (*Phil. Mag.* 1911, [vii], 21, 92) in developing a theory of molecular forces. Kleeman applied the formula to a few liquids only, and discarded the theory on which it was based, since the data for latent heats did not give satisfactory agreement with his theory. Later Macleod (*Trans. Faraday Soc.* 1923,19, 38) independently discovered this relationship and showed that it held with remarkable accuracy for a large number of liquids.

Since Macleod's rule gives an accurate relationship between surface tension and density it can be used to compare the molecular volumes of liquids at temperatures at wjjich they have the same surface tension (Sugden, *J.C.S.* 1924, 125, 1185)> Let y<sub>x</sub> be some arbitrary surface tension at which the comparison is to be made, and D<sub>x</sub> and d<sub>x</sub> the density of the liquid and vapour respectively at the temperature at which the liquid has this surface tension. At some other temperature let y, D<sub>0</sub> and d be the values of these quantities. Then, from Macleod's equation (1):

$$y_x^{1/4} / (D_x - d_x) = O^4 = y^{1/4} / (D - d)$$

Therefore  $D_x - d_x = (D - d) (y_x^{1/4} / y^{1/4})$ .

If yjW suitably chosen then d<sub>x</sub> is negligibly small compared with D<sub>x</sub>. Let M be the molecular weight; then the molecular volume in the liquid state at a surface tension j^ is given by

$$M \{ D^4 (Mly) \{ y^4 (D - d) \}^4 lly \} C^4 M \dots (2)$$

It is thus proportional to the fourth root of the Maclqod constant (determined from experiments at any convenient temperature), multiplied by the molecular weight.

It is evident from (2) that the value chosen for the arbitrary surface tension y<sub>x</sub> merely affects the magnitude of the factor 1/yf; it is therefore convenient to choose y<sub>x</sub>=1 so that

$$[P] = M y^{1/4} / (D - d) = M C^4 \dots (3)$$

The quantity [P] defined by equation (3) is termed the "parachor" (from *irapa*, \*\* set by the side of," and  $x^{\wedge}P^{\wedge}$  "  $^8 P^{acc}$  ") (Sugden, *ibid.* 1924, 125, 1185).

The chief significance to be attached to this method of comparing molecular volumes is that some allowance is made for the effect of the large internal pressure of a liquid upon the volume occupied by its molecules. This internal pressure cannot, unfortunately, be measured directly, but it is known to have very different values in different liquids and to decrease rapidly with increasing temperature. Since surface tension and internal pressure are both due to the attraction between the molecules, a comparison of molecular volumes at constant surface tension should eliminate the effect of gross differences of internal pressure and give a better measure of the volume of the molecule. Some evidence in favour of this view is furnished by a comparison of parachors with critical volumes and mean collision areas (Sugden, *ibid.* 1929, 1055).

#### Additive Properties of the Parachor.—

When the parachors of members of homologous series are tabulated it is found that there is a nearly constant increment of 39.0 units for each additional  $C_2H_4$  group. Also, isomeric substances which differ only in the position of groups in the molecule have almost identical parachors. Further examination shows that molecular parachors can be predicted with considerable accuracy by adding together suitable constants for the atoms and linkages present in the molecule. (A list of these constants is given in Table I.)

The constants for atoms are found to be nearly the same in all their compounds, and the structural constants appear to be independent of the nature of the atoms to which the linkage is attached. An example of this behaviour is furnished by the data for double bonds in Table II. It will be seen that the constant for this structure is always approximately 23 units in  $C=C$ ,  $C=O$ ,  $C=S$ ,  $C=Se$ ,  $N=C$ ,  $rj=O$ , and  $N=N$ , ( $2[P]$  is the sum of the appropriate atomic and structural constants excluding that under investigation; the latter is obtained by subtracting  $27[P]$  from  $[P]$  (obs.).

The use of these constants in calculating molecular parachors is shown by the following examples.

Benzene. CH	P&aldehyde. O
HC ^ NH	CH <sub>3</sub> (5H    HCCH <sub>3</sub> )
1    »	i    d
HC    CH	U
<b>Sr.</b>	
C <sub>6</sub> 6x4-8 . . . 28-8	C <sub>6</sub> 6x4-8 . . . 28-8
H <sub>6</sub> 6x17-1 . . . 102-6	H <sub>12</sub> 12x17-1 . . . 205-2
8 double bonds, . . . 69-6	O <sub>3</sub> 3x200 . . . 600
3 v 23-2 . . . 6-1	6 ring . . . 61
6 ring . . . 6-1	
[P] (calc.) . . . 2071	[P] (calc.) . . . 3001
[P] (tbl.) . . . 2061	[P] (tbl.) . . . 298-7

Of the corrections listed in Table I the first is applicable to esters, which are found to exhibit a nearly constant anomaly of -3.2 units. The

TABLE I.—ATOMIC AND STRUCTURAL  
-PABACHOBS.

Aluminium . . . . .	38*6
Antimony . . . . .	66-0
Argon . . . . .	540
Arsenic . . . . .	50-3
Barium . . . . .	(106)
<b>Beryllium</b> . . . . .	<b>37-8</b>
<b>Bismuth</b> . . . . .	(80)
<b>Boron</b> . . . . .	16-4
<b>Bromine</b> . . . . .	680
<b>Cadmium</b> . . . . .	(70)
Cesium . . . . .	(150)
Calcium . . . . .	(68)
Carbon . . . . .	4-8
Chlorine . . . . .	54-3
Chromium . . . . .	53-7
Copper . . . . .	(46)
Fluorine . . . . .	25-7
Gallium . . . . .	50
Germanium . . . . .	(36)
Gold . . . . .	61
Helium . . . . .	20-5
Hydrogen . . . . .	17-1
Iodine . . . . .	91-0
Lead . . . . .	76-2
Lithium . . . . .	(50)
Mercury . . . . .	68-7
Molybdenum . . . . .	(80)
Neon . . . . .	<b>25-0</b>
Nickel . . . . .	(50)
Nitrogen . . . . .	12-5
Osmium . . . . .	80-4
Oxygen . . . . .	200
Phosphorus . . . . .	37-7
Potassium . . . . .	1110
Rubidium . . . . .	(130)
Selenium . . . . .	62-5
Silicon . . . . .	27-8
Silver . . . . .	63
Sodium . . . . .	(80)
Sulphur . . . . .	48-2
Tellurium . . . . .	<b>79-4</b>
Thallium . . . . .	64
Tin . . . . .	56-7
Titanium . . . . .	45-3
Tungsten . . . . .	(90)
Zinc . . . . .	50-7
<b>Triple bond</b> . . . . .	46-6
<b>Double bond</b> . . . . .	23-2
<b>Single bond</b> . . . . .	0
<b>Semipolar double bond</b> . . . . .	- 1-6
<b>Singlet link</b> . . . . .	- 11-6
<i>Rings.</i>	
3-membered . . . . .	16-7
4-membered . . . . .	11-6
5-membered . . . . .	8-5
6-membered . . . . .	6-1
<i>Corrections.</i>	
Ester group . . . . .	-3-2
OH-group . . . . .	-5-0
NH <sub>2</sub> , NHR, or NR <sub>2</sub> . . . . .	-6-0

(Parentheses indicate parachors which are only roughly determined.)

TABLE II.—NON-POLAR DOUBLE BONDS.

Substance.	Formula.	[P] (obs.).	Z[P].	Double bond.
Ethylene . . . . .	$H_2C=CH_2$	99.5	780	21.5
Propylene . . . . .	$H_2C=CHMe$	139.9	117.0	22.9
Acetone . . . . .	$Me_2C=O$	161.5	1370	24.5
Methyl ethyl ketone . . . . .	$MeEtC=O$	198.5	1760	22.5
Carbon disulphide . . . . .	$S=C=S$	144.7	101.2	21.7x2
Carbon selenosulphide . . . . .	$S=C=Se$	156.4	115.5	20.4x2
Ethylthiocarbimide . . . . .	$EtN=C=S$	211.7	160.6	25.5x2
Nitrosyl chloride . . . . .	$ClN=O$	108.1	86.8	21.3
Azobenzene . . . . .	$PhN=NPh$	479.5	4050	24.5

others can be regarded as a rough allowance for the effect of association in alcohols and amines. This method of correcting for association can only be expected to hold roughly at not too elevated temperatures? since the parachors of associated liquids vary with temperature.

Accuracy of the Additive Properties of the Parachor.—Of 167 parachors collected by Sugden in 1924 (*i.e.*) 104 are within 1% of the calculated value and 145 within 2%. Later work on a much larger number of compounds has shown that this order of accuracy is usually found. One important exception was discovered by IVRm and Purdie (*ibid.* 1935, 1549) in certain series of organometallic compounds. Thus in the homologous series of compounds represented by the formula  $(SR_2)_2PdCl_2$  the parachor deduced for palladium fell from 36 for R=Me to -7 for R=w-amyl. Large anomalies are also found for some fused metals and salts (*see later*). Many of the deviations found for purely organic substances are probably due to incorrect measurements or to insufficient purification, whilst others may be caused by modifications in structure which have not been allowed for in calculating the parachor (*a.g.*, substituted phorones, Sugden, *ibid.* 1928, 410). Much better agreement could not be hoped for since (a) small differences are found between the values for  $CH_2$  differences in different homologous series, and (9) parachors of position isomers indicate that there are small but definite deviations from a strictly additive law. In view of these facts it is evident that conclusions as to structure can only safely be made from parachor values when

the alternative structures would lead to considerable differences in parachor.

Mumford and Phillips (*ibid.*, 1929, 2112) have suggested the use of strain constants to account for some of these variations. These constants are small and usually of the magnitude of the experimental error; it is only when several of these corrections have to be applied for one molecule that they become important. A number of other schemes of parachor constants have been suggested by other writers, but except possibly in considering data for closely related compounds they do not seem to offer any particular advantages. (In the article on the parachor in the 1934 Supplement to this Dictionary a modified series of constants was used based on a slightly higher value for the  $CH_2$  difference. Later work showed that this did not lead to any substantial advantages and the original constants were reverted to. It is these original constants which are quoted in Table I.)

Semipolar Double Bonds.—The electronic theory of valency leads to a modification of the formulae for compounds of polyvalent elements in which double bonds are written. Thus phosphorus oxychloride is now formulated as (I) or (II) instead of the older formula (III). One pair

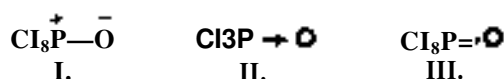

of electrons only is shared between the phosphorus and oxygen atoms, and these are both supplied by the phosphorus atom. Hence

TABLE III.—SEMPOLAR DOUBLE BONDS.

Substance.	Formula.	[P] (obs.).	Z[P].	Semipolar double bond.
Phosphorus oxychloride . . . . .	$Cl_3P \rightarrow O$	217.6	220.6 *	-3.0
Ethyl phosphate . . . . .	$(EtO)_3P \rightarrow O$	399.1	4030	-3.9
Thionylchloride . . . . .	$Cl_2S \rightarrow \overset{\ominus}{S}$	174.5	176.8	-2.3
Sulphuryl chloride . . . . .	$C \leftarrow \overset{\ominus}{S}$	193.3	196.8	-1.75x2
Methyl sulphate . . . . .	$(MeO)_2S \leftarrow \overset{\ominus}{O}$	238.9	240.4	0.75x2
Ethyl sulphate . . . . .	$(EtO)_2S \leftarrow \overset{\ominus}{O}$	313.8	318.4	-4.6x2

Sidgwick (*ibid.* 1923, 123, 725) terms this the "donor" atom and has described the bond as a "co-ordinate link." Lowry (*Trans. Faraday Soc.* 1923, 18, 285) pointed out that if the electrons are equally shared a polar bond is also present as indicated in (I); for this reason Sugden (*ibid.* 1925, 127, 1528) uses the term "semipolar double bond" to describe this linkage.

It is found that the parachor contribution of a semipolar double bond is about  $-1.2$ , whilst that of a non-polar double bond in ethylene, ketones, etc., is  $+23.2$ . Some examples of semipolar double bonds are given in Table III, which should be compared with Table II.

The parachor can therefore be used to investigate the nature of the bond in particular substances. This method has been applied to compounds of a number of different elements and the conclusions reached are summarised in Table IV. (This Table contains a few cases, e.g., wonitriles, in which a polar bond is superimposed on more than one covalent bond.) It is noteworthy that in every case so far examined the structure assigned is in harmony with the "octet rule" although, in many cases, a shell of more than eight electrons around the central atom could readily be attained by converting semipolar double bonds into non-polar double bonds.

Single Linkages.—The structure of the higher halides of the elements of Groups V, VI, VII, and VIII of the Periodic Table is capable of two interpretations in terms of the electronic theory of valency. One may assume that the octet breaks down and that all the halogen atoms in  $PCl_6$ , for example, are held by duplet linkages giving a shell of ten electrons around the phosphorus atom (Formula IV). Alternatively it may be assumed that the octet rule still holds and that in this substance two of the chlorine atoms are held by singlet linkages (Formula V). On the latter view it would be

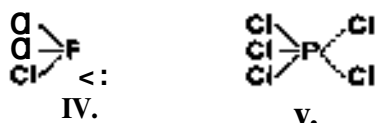

expected that the link consisting of one shared electron (indicated . . .) would have a parachor of about  $-11.6$ , since the constant for a four-electron link is 23.2 units higher than the value (zero) arbitrarily adopted for a two electron link. The parachors of a number of compounds of this type show negative anomalies of approximately this magnitude (Table V).

The theory of odd electron linkages has been applied by Sugden to account for the parachors of "a number of co-ordination compounds. For further details, see S. Sugden, "The Parachor and Valency," Routledge, 1930, Chapter VII; Sugden and Waloff, *J.C.S.* 1932, 1492; and for criticisms of the hypothesis of singlet linkages, see N. V. Sidgwick, "The Electronic Theory of Valency," Oxford, 1927, p. 128; Sidgwick and Barkworth, *J.C.S.* 1931, 807; Sidgwick and Baylies, *ibid.* 1930, 2027; Sippel, *Ber.* 1930, 63 [B], 2185; Simons, *J. Physical Chem.* 1931, 86, 118.

TABLE IV.—OCCURRENCE OF NON-POLAR AND SEMIPOLAR DOUBLE BONDS.

Group.	Formula.	Reference.
Ethylene . . .	$\text{V} \begin{array}{l} \diagup \\ \diagdown \end{array} \text{C} = \text{C} \begin{array}{l} \diagdown \\ \diagup \end{array} \text{V}$	(1)
Carbonyl . . .	$\text{V} \begin{array}{l} \diagup \\ \diagdown \end{array} \text{C} = \text{O} \begin{array}{l} \diagdown \\ \diagup \end{array} \text{V}$	(2)
Thiocarbonyl . . .	$\text{V} \begin{array}{l} \diagup \\ \diagdown \end{array} \text{C} = \text{S} \begin{array}{l} \diagdown \\ \diagup \end{array} \text{V}$	(3)
Selenocarbonyl . . .	$\text{V} \begin{array}{l} \diagup \\ \diagdown \end{array} \text{C} = \text{Se} \begin{array}{l} \diagdown \\ \diagup \end{array} \text{V}$	(4)
Thiocarbixide . . .	$\text{V} \begin{array}{l} \diagup \\ \diagdown \end{array} \text{N} = \text{C} = \text{S} \begin{array}{l} \diagdown \\ \diagup \end{array} \text{V}$	(5)
Nitroso . . .	$\text{V} \begin{array}{l} \diagup \\ \diagdown \end{array} \text{N} = \text{O} \begin{array}{l} \diagdown \\ \diagup \end{array} \text{V}$	(6)
Nitrite . . .	$\text{V} \begin{array}{l} \diagup \\ \diagdown \end{array} \text{N} = \text{O} \begin{array}{l} \diagdown \\ \diagup \end{array} \text{O} \begin{array}{l} \diagdown \\ \diagup \end{array} \text{V}$	(7)
Azo . . .	$\text{V} \begin{array}{l} \diagup \\ \diagdown \end{array} \text{N} = \text{N} \begin{array}{l} \diagdown \\ \diagup \end{array} \text{V}$	(8)
Nitro . . .	$\text{V} \begin{array}{l} \diagup \\ \diagdown \end{array} \text{N} = \text{O} \begin{array}{l} \diagdown \\ \diagup \end{array} \text{O} \begin{array}{l} \diagdown \\ \diagup \end{array} \text{V}$	(9)
Azoxy . . .	$\text{V} \begin{array}{l} \diagup \\ \diagdown \end{array} \text{N} = \text{O} \begin{array}{l} \diagdown \\ \diagup \end{array} \text{N} \begin{array}{l} \diagdown \\ \diagup \end{array} \text{V}$	(10)
Oximino . . .	$\text{V} \begin{array}{l} \diagup \\ \diagdown \end{array} \text{O} = \text{N} \begin{array}{l} \diagdown \\ \diagup \end{array} \text{O} \begin{array}{l} \diagdown \\ \diagup \end{array} \text{V}$	(11)
Diazo . . .	$\text{V} \begin{array}{l} \diagup \\ \diagdown \end{array} \text{C} = \text{N} = \text{N} \begin{array}{l} \diagdown \\ \diagup \end{array} \text{V}$	(12)
Diazoyl . . .	$\text{V} \begin{array}{l} \diagup \\ \diagdown \end{array} \text{C} = \text{N} = \text{N} \begin{array}{l} \diagdown \\ \diagup \end{array} \text{N} \begin{array}{l} \diagdown \\ \diagup \end{array} \text{V}$	(13)
Wynitrile . . .	$\text{V} \begin{array}{l} \diagup \\ \diagdown \end{array} \text{N} = \text{N} \begin{array}{l} \diagdown \\ \diagup \end{array} \text{C} \begin{array}{l} \diagdown \\ \diagup \end{array} \text{V}$	(14)
Phosphate . . .	$\text{V} \begin{array}{l} \diagup \\ \diagdown \end{array} \text{P} = \text{O} \begin{array}{l} \diagdown \\ \diagup \end{array} \text{P} \begin{array}{l} \diagdown \\ \diagup \end{array} \text{O} \begin{array}{l} \diagdown \\ \diagup \end{array} \text{V}$	(15)
Sulphoxide . . .	$\text{V} \begin{array}{l} \diagup \\ \diagdown \end{array} \text{S} = \text{O} \begin{array}{l} \diagdown \\ \diagup \end{array} \text{S} \begin{array}{l} \diagdown \\ \diagup \end{array} \text{O} \begin{array}{l} \diagdown \\ \diagup \end{array} \text{V}$	(16)
Sulphite . . .	$\text{V} \begin{array}{l} \diagup \\ \diagdown \end{array} \text{S} = \text{O} \begin{array}{l} \diagdown \\ \diagup \end{array} \text{O} \begin{array}{l} \diagdown \\ \diagup \end{array} \text{O} \begin{array}{l} \diagdown \\ \diagup \end{array} \text{V}$	(17)
Sulphinate . . .	$\text{V} \begin{array}{l} \diagup \\ \diagdown \end{array} \text{S} = \text{O} \begin{array}{l} \diagdown \\ \diagup \end{array} \text{O} \begin{array}{l} \diagdown \\ \diagup \end{array} \text{O} \begin{array}{l} \diagdown \\ \diagup \end{array} \text{O} \begin{array}{l} \diagdown \\ \diagup \end{array} \text{V}$	(18)
Sulphate . . .	$\text{V} \begin{array}{l} \diagup \\ \diagdown \end{array} \text{S} = \text{O} \begin{array}{l} \diagdown \\ \diagup \end{array} \text{O} \begin{array}{l} \diagdown \\ \diagup \end{array} \text{O} \begin{array}{l} \diagdown \\ \diagup \end{array} \text{O} \begin{array}{l} \diagdown \\ \diagup \end{array} \text{O} \begin{array}{l} \diagdown \\ \diagup \end{array} \text{V}$	(19)
Sulphonate . . .	$\text{V} \begin{array}{l} \diagup \\ \diagdown \end{array} \text{S} = \text{O} \begin{array}{l} \diagdown \\ \diagup \end{array} \text{O} \begin{array}{l} \diagdown \\ \diagup \end{array} \text{O} \begin{array}{l} \diagdown \\ \diagup \end{array} \text{O} \begin{array}{l} \diagdown \\ \diagup \end{array} \text{O} \begin{array}{l} \diagdown \\ \diagup \end{array} \text{V}$	(20)
Sulphone . . .	$\text{V} \begin{array}{l} \diagup \\ \diagdown \end{array} \text{S} = \text{O} \begin{array}{l} \diagdown \\ \diagup \end{array} \text{O} \begin{array}{l} \diagdown \\ \diagup \end{array} \text{S} \begin{array}{l} \diagdown \\ \diagup \end{array} \text{O} \begin{array}{l} \diagdown \\ \diagup \end{array} \text{V}$	(21)
Selenoxide . . .	$\text{V} \begin{array}{l} \diagup \\ \diagdown \end{array} \text{Se} = \text{O} \begin{array}{l} \diagdown \\ \diagup \end{array} \text{Se} \begin{array}{l} \diagdown \\ \diagup \end{array} \text{O} \begin{array}{l} \diagdown \\ \diagup \end{array} \text{V}$	(22)
Chromate . . .	$\text{V} \begin{array}{l} \diagup \\ \diagdown \end{array} \text{Cr} = \text{O} \begin{array}{l} \diagdown \\ \diagup \end{array} \text{Cr} \begin{array}{l} \diagdown \\ \diagup \end{array} \text{O} \begin{array}{l} \diagdown \\ \diagup \end{array} \text{O} \begin{array}{l} \diagdown \\ \diagup \end{array} \text{V}$	(23)
Osmium tetroxide . . .	$\text{Os}(\text{O})_4$	(24)
Additive compounds of $\text{BF}_3$ and ethers . . .	$\text{V} \begin{array}{l} \diagup \\ \diagdown \end{array} \text{O} \begin{array}{l} \diagdown \\ \diagup \end{array} \text{B} \begin{array}{l} \diagdown \\ \diagup \end{array} \text{F}_3 \begin{array}{l} \diagdown \\ \diagup \end{array} \text{O} \begin{array}{l} \diagdown \\ \diagup \end{array} \text{V}$	(25)

#### References.

- » Sugden, *J.C.S.* 1924, 125, 117.  
 J Sugden, Iteed, and Wilkins, *ibid.* 1925, 187, 1525.  
 \* Henley and Sugden, *ibid.* 1929, 1054.  
 4 Lindemann and Groger, *Ber.* 1930, 63 [B], 715.  
 5 Lindemann, Walter, and Groger, *ibid.* 1930, 63 [B], 702.  
 6 Lindemann and Thiele, *ibid.* 1928, 51 [B], 1629.  
 7 Freeman and Sugden, *J.C.S.* 1932, 1493.  
 J Briscoe, Peel, and Bobinson, *ibid.* 1930, 56.  
 » Lindemann and Wiegrabe, *Ber.* 1930, 63 [B], 1650.  
 10 Hammlck, New, Sidgwick, and Button, *J.C.S.* 1930, 1876.  
 11 Sugden and Waloff, *ibid.* 1932, 1492.

#### Other Applications of the Parachor.—

Since the parachor is nearly an additive property and is little affected by the position of an atom or linkage in the molecule its application to

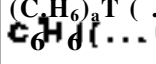

TABLE V.—SINGLET LINKAGES.

Substance.	Formula.	[PKobs.).	*n	(Singlet).	References.
Phosphorus pentachloride	Cl <sub>3</sub> P( . . . Cl) <sub>a</sub>	282.5	309.2	-13.3	
Antimony pentachloride	Cl <sub>3</sub> Sb( . . . Cl) <sub>a</sub>	311.8	337.5	-12.8	
Selenium dihydroxydichloride	(HO) <sub>2</sub> Se( . . . Cl) <sub>a</sub>	222.8	245.3	-11.2	
Tellurium tetrachloride	Cl <sub>2</sub> Te( . . . Cl) <sub>3</sub>	268.1	296.6	-14.2	
Diphenyl telluridichloride	Ph <sub>2</sub> Te( . . . Cl) <sub>2</sub>	547.3	568.0	-10.3	
Dianisyl telluridichloride	(C <sub>7</sub> H <sub>7</sub> O) <sub>2</sub> Te( . . . Cl) <sub>a</sub>	663.2	686.0	-11.4	
Dimethyl telluridichloride	(CH <sub>3</sub> ) <sub>2</sub> Tf( . . . Cl) <sub>2</sub>	282.6	300.2	-8.8	
Diethyl telluridi-iodide	(C <sub>2</sub> H <sub>5</sub> ) <sub>2</sub> T( . . . Cl) <sub>a</sub>	742.50	451.6	-13.3	(4.5)
Iodosobenzene propionate		583.5	600.8	-8.6	(*)

## References.

- 1 Sugden, J.C.S. 1927, 1173.
- 2 Henley and Sugden, *ibid.* 1929, 1058.
- 3 Simons, J. Amer. Chem. Soc. 1930, 52, 3488.

- \* BurstaU and Sugden, J.C.S. 1930, 220.  
*i* Lowry and Gilbert, *ibid.* 1929, 2087.  
 < Sidgwick and Barkworth, *ibid.* 1931, 807.

problems of organic structure is limited. 'Apart from the cases already considered which involve the presence or absence of specific linkages causing a large change in parachor, the most important group of compounds for which this constant can give information about structure is that in which the possible structures involve either a ring or a non-polar double bond. Thus the replacement of a double bond by a six-membered ring causes a fall in parachor of 17 units and this is well within the limits imposed by experiment and by lack of strict additivity unless the molecule is very large and complex. This alternative is found in the formulae for quinones; the diketone formula (VII), and the peroxide structure (VI) is correct (Garner and Sugden, J.C.S. 1927, 2877). Similarly succinyl chloride and the lower-melting form of phthalyl chloride have probably the symmetrical structure (VIII), whereas the higher-melting, unstable form of phthalyl chloride has probably the unsymmetrical structure (IX). Benzil and *p*-dimethoxybenzil are

also found to have the diketone structure (X) and not the peroxide structure (XI) (Garner and Sugden, *l.c.*).

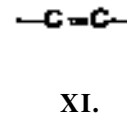
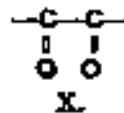

A somewhat similar problem is found in the derivatives of phorone which have been studied by Ingold and Shoppee (*ibid.* 1928, 365). According to the nature of the substituent X these substances show a greater or smaller tendency to pass from the open chain form (XII) to the bicyclic form (XIII). The parachors show a negative anomaly which corresponds roughly to the degree to which the bicyclic form is present.

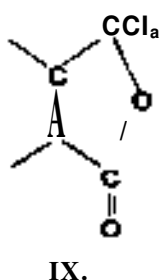
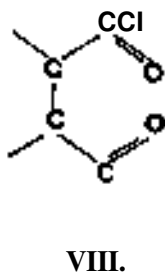
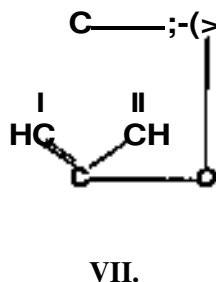
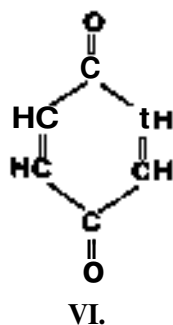
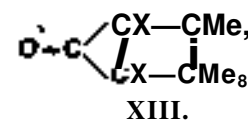
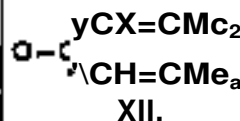

An application of the parachor to a problem of a rather different type has been made by Mumford and Phillips (*ibid.* 1928, 155). When *o*-dichlorodiethyl sulphide is chlorinated, two substances occur among the products, to which the formulae C<sub>4</sub>H<sub>7</sub>Cl<sub>5</sub>S and C<sub>4</sub>H<sub>6</sub>Cl<sub>4</sub>S were originally assigned. Later analyses showed that the formulae were more probably C<sub>4</sub>H<sub>6</sub>Cl<sub>3</sub>S and C<sub>4</sub>H<sub>4</sub>Cl<sub>4</sub>S and that a molecule of hydrogen chloride had been eliminated during the chlorination to give derivatives of vinyl ethyl sulphide. Hydrogen analyses are rather difficult to carry out with accuracy in these highly chlorinated compounds, but a determination of their parachors confirmed the unsaturated structures. Neglecting the small difference due to the change in molecular weight of two units, the difference in parachor between the values expected for the saturated and unsaturated formula is equal to the difference between the constants for two hydrogen atoms and that for a non-polar double bond, viz. 34.2-23.2=11.0; each substance was found to have a parachor agreeing with the unsaturated formula.

One important group of substances in which large and unexplained parachor anomalies exist is formed by fused metals and salts. All these substances are not anomalous; thus mercury and copper have parachors which are not far from the constants obtained from their fusible compounds with organic addenda, and certain salts of amines give normal parachors. Many other salts and metals, however, exhibit large parachor anomalies which may be either positive or negative. For a fuller discussion of these, see S. Sugden, *op cit.*, Chap. VIII; Mumbrd and Phillips, J.C.S. 1929, 2112.

S. S.

**PARADOL.** A yellow pungent oil contained in the seeds—Grains of Paradise, Guinea Grains—of a West African plant, *Aframomum melegueta* (Fam. Zingiberaceae). The seeds were formerly important as a spice and are still prescribed as a carminative in veterinary medicine. Nelson (J. Amer. Chem. Soc. 1917, 39, 1466) separated paradol from the essential oil also contained in the seeds but did not obtain it in a pure state. Crude paradol had  $n_D^{20}$  1.0690,  $[\alpha]_D^{20}$  +9.2°,  $n_D^{25}$  1.5232, OMe 10.93%. Treatment with dimethyl sulphate gave the methyl ether, m.p. 65-65.5°, OMe 20%. This substance he considered to be identical with the methyl ether of gingerol (Lapworth *et al.*, J.C.S. 1917, 111, 777; v. Vol. V, 533d, 534c).

The principal fraction of paradol distilled at 230-234°/8 mm., had  $n_D^{20}$  1.0415,  $n_D^{25}$  1.5198, OMe 11.1%, and was optically inactive. The identity with gingerol claimed by Nelson leaves unexplained the different reaction with boiling potassium hydroxide; gingerol loses its pungency, while paradol is recovered unaltered. Gingerol (Lapworth *et al.*, *l.c.*, p. 789) and probably also paradol are complex mixtures. For further information on *A. melegueta*, see J. Hutchinson and J. M. Dalziel, "Useful Plants of West Tropical Africa," Crown Agents for the Colonies, London, 1937, 471; also Vol. I, 161a.

J. N. G.

**PARAFFIN WAX** (v. PETROLEUM WAXES, this Vol., p. 403d).

**PARAGUAY TEA** or *Yerba de Matt*, also known as *Matt*, *Jesuit's Tea*, or *St. Bartholomew's Tea*, is a product of *Ilex paraguensis* (and other species of *Ilex*) which, indigenous to Paraguay and Southern Brazil, is now cultivated also in Argentina, Chile, and Peru. The plant is a tall shrub, bearing ovate-lanceolate leaves about 5 in. long, with serrated edges; the midrib and veins are prominent at the under side, and the veins join again before reaching the edge of the leaf, as in the case of ordinary tea. The dried and comminuted leaves are widely used as a beverage in South America, and to a small extent elsewhere. A variety termed *Youpon* or *Cassine*, from *Ilex cassine*, is grown and used in some of the southern states of U.S.A.

In the preparation of mate, the old and somewhat crude methods have been superseded. Cut branches bearing leaves are dried by means of hot air, the leaves and stems detached by threshing; these, after a final complete drying in a current of hot air, are broken up and packed.

The infusion is made by adding boiling water to mate\* in a cup<sup>p</sup>; after sweetening, it is imbibed, usually very hot, by means of a tube fitted with a filter. Two or three successive infusions may be obtained from one lot of mate\*. The liquor has restorative and invigorating qualities. It is also variously reputed to be aperient, emetic, and diuretic; the last-named quality has been attributed by Oehrli (Pharm. Acta Helv. 1927, 2, 155) to a small content (0.1%) of theobromine. Use of the infusion dates only from the settlement of Jesuit missionaries in South America in the early seventeenth century.

In Argentina the quality of mate<sup>h</sup> is controlled by law. That prepared by primitive processes is not admitted; not more than 25% of stalk or 20% of fine dust is allowed. Other limits of composition are: *maxima*, moisture 10%, ash 8%, acid-insoluble ash 9%; *minima*, aqueous extract 25%, caffeine 0.7% (see also B, 1938, 1500p).

Published percentage analyses range as follows:

Moisture	70-10-5
Aqueous extract	32-0-49-0
Caffeine	0-4-1-6
"Tannin"	80-11-Q
Ash	5-0-7-5
Crude fibre	15-0-20-0

(Friese, Pharm. Zentr. 1936, 77, 53; Krauze, *Mitt. Lebensm. Hyg.* 1932, 23, 218-223; Peyer and Gstirner, *Apoth.-Ztg.* 1932, A'-C72-675; Connecticut Agric. Exp. Station reports, 1930 and 1934).

Mate contains no true tannin, but caffetannin or a closely-allied compound. The aqueous extract affords a fine green colour with 10% ammonia. It also contains an appreciable proportion of a natural yellow colouring matter, which is probably a flavone derivative (Woodard and Cowland, *Analyst*, 1935, 60, 135).

Reference may also be made to Joyce, *Nature*, 1934, 722 and 760.

*Yerbat* is the name given to a carbonated infusion of mate, sweetened and flavoured (*Analyst*, 1932, 57, 169).

T. W. H.

**PARAMAGNETISM** (v. Vol. VIII, 4626)!

**"PARAMOL"** 2-Amino-5-hydroxybenzyl alcohol. A photographic developer described by Eichengrün (*Z. angew. Chem.* 1901, 14, 1070). It is prepared from p-nitrophenol which is converted into a derivative of benzyl chloride by interaction with hydrochloric acid and formaldehyde; this product is then reduced to the amino compound and at the same time the chlorine atom is replaced by hydroxyl. Its properties as a developer are intermediate between those of pyrogallol and p-aminophenol. Concentrated stock solutions can be prepared in sodium carbonate solution. It is a developer suitable for both plates and papers but has not attained importance. "Paramol," constitution above, should be distinguished from "paranol" which is p-aminophenol.

J. N. G.

PARAXANTHINE, or *hl-dimethylxanthine*,  $C_7H_8O_2N_4$ ,

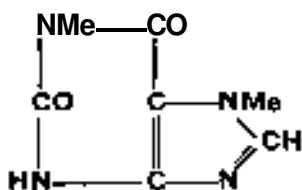

is a colourless crystalline substance, m.p. 398-299°, difficultly soluble in cold water, but soluble in about 24 parts of boiling water. It occurs naturally in human urine (Kruger and Salomon, *Z. physiol. Chem.* 1897, 24, 364; 1898, 26, 350) and in whale's liver (Carter, Mann, Jenkins, and Harley-ittason, *Nature*, 1943, 151, 728). It has a marked diuretic action; furthermore, anti-thyroid activity has also been claimed for paraxanthine (Carter *et al.*, *I.e.*), although the physical basis of this claim requires further investigation. Paraxanthine was first synthesised by Fischer and Ach (*Ber.* 1906, 39 423), who converted 8-chlorocaffeine to 8-chloro-3-chloromethylparaxanthine, which, when boiled with water, furnished 8-chloroparaxanthine, from which paraxanthine was obtained by reduction with hydrogen iodide. This synthesis has recently been modified and improved by Mann and Porter (*J.C.S.* 1946 751). A second synthesis, by the Traube series of reactions, was carried out by Traube and Dudley (*Ber.* 1913, 46, 3839). A third synthesis, in which 4-amino-1-methylimidazol-5-carboxylmethylamide cyclised with ethyl chloroformate, was performed by Mann and Porter (*I.e.*), who also synthesised various homologous 1:7-dialkylxanthines.

These syntheses place the main structure of paraxanthine beyond doubt. The fine structure is not certain and is probably dependent on the chemical environment; Ogston, (*J.C.S.*, 1935, 1376), on the basis of dissociation-constant measurements, has allocated a zwitterion structure to paraxanthine. For absorption spectra of paraxanthine and homologues, see Mann and Porter (*I.e.*).

Paraxanthine forms a well-defined sodium derivative,  $C_7H_7O_2N_4Na \cdot 4H_2O$ , which is only slightly soluble in water, and a picrate,  $C_7H_8O_2N_4 \cdot C_6H_3O_7N_3$ , m.p. 247-249° (decomp.). Methylation with methyl iodide converts paraxanthine to caffeine.

Paraxanthine is isomeric with theophylline (1:3-dimethylxanthine) and theobromine (3:7-dimethylxanthine).

F. G. M.

**PARCHMENT.** *Vellum.* Rolls of animal skin had been used for written records in 1500 B.O. but according to tradition it was Eumenes II of Pergamum (197-158 B.O.) who first established the manufacture of parchment and vellum as improved supports for writing. Moreover, both surfaces of these sheets could be used so that it was an obvious development to bind the sheets together to form codices or books (E. M. Thompson, "Greek and Latin Paleography," Oxford, 1912; F. G. Kenyon, "Books and Readers in Ancient Greece and Rome," Oxford, 1932).

The modern manufacture is believed to resemble the ancient practice and may be summarised as follows: Sheep and she-goat skins are used for parchment, skins of finer quality from calves, kids, and newly-born lambs yielding vellum. The skin after soaking in a lime pit (*v.* Vol. VII, 2636) is shaved, washed, and pegged out tightly on a wooden frame to dry. Both sides of the skin are now scraped with a knife, the flesh side is sprinkled with chalk or slaked lime and rubbed with pumice stone; at this stage the grain side is only rubbed with pumice stone, and the skin is allowed to dry upon the frame. The skin is next transferred to another frame where it remains at a lower tension than before, and its thickness is equalised by scraping the grain side with a sharp knife; finally, any irregularities are removed by rubbing with fine pumice stone ("Ure's Dictionary of Arts, Manufactures, and Mines," by R. Hunt and F. W. Rudler, 7th ed., London, 1875, III, 513; *cf.* Band, B.P. 11693, 1893; 14384, 1894).

Papyrus, the writing material of the ancient world, which remained in use until the fifth century A.D., was prepared by cutting vertical strips from the stem of the paper reed, *Cyperus papyrus*, which flourished in the Nile delta. The strips were arranged at right-angles in two layers which were pasted together, pressed, and dried in the sun. The sheets were then fastened together to form a band which was wound up on two sticks (Pliny, *Nat. Hist.* XIII, co. 11, 12). The papyrus roll was eventually superseded by the parchment or vellum codex or book.

J. N. G.

**PARCHMENT PAPER.** *Vegetable Parchment* is a modified paper, glossy, semi-transparent, and tough, resembling parchment. It is produced from selected papers, preferably rag or bleached sulphite cellulose, by the action of either sulphuric acid, zinc chloride solution, or ammonium solution. The parchmentising treatment applied to cellulose material is usually understood to mean the sulphuric acid process. Cotton fabrics can be parchmentised to give a variety of effects, from semi-transparent to wool-like (*v.* Vol. V, 191).

In the manufacture of parchment paper by a continuous process a band of paper is passed under glass or lead rollers revolving in sulphuric acid (about 77%) and kept at a temperature between 10° and 15°. The speed of the paper band is adjusted to give a predetermined time of contact with the acid of between 5 and 20 seconds. The nature and porosity of the paper are factors affecting the duration of contact. The treated paper passes between rollers which squeeze out the excess of acid and then through washing tanks, one of which contains dilute ammonia. The final washing (Arnold, B.P. 8130, 1855) is by a water-spray. Neutrality is important. The washed paper is then dried by passage over heated felt-covered cylinders and is calendered. A suitable arrangement of tanks and adjustable rollers is described by Sanson (*J.S.C.I.* 1912, 31, 636). The prolonged action of sulphuric acid on cellulose has been frequently studied, notably by Girard (1875) who prepared hydrocellulose, a friable substance, with a dilute acid and by Stern (1895) who

obtained cellulose sulphuric acid esters in solution in the concentrated acid. Mercer (1850) observed the parchmentising effect of a brief contact with sulphuric acid of 77%, and Warrea de la Rue (1861) manufactured parchment paper. Some later researches have been directed to the possible formation of cellulose hydrate under parchmentising conditions. The cellulose is gelatinised and swollen by the action of the acid and the effect of water is to precipitate a cellulose colloid (formerly termed "amyloid") on and between the fibres. The product is more hygroscopic than the original cellulose, but does not appear by *X-T&J* examination to be a hydrate of cellulose (see Vol. II, 459; J. T. Marsh and F. C. Wood, "Chemistry of Cellulose," 3rd ed., London, 1945; Sakurada *et al.*, Applied Chemistry Reports, 1933, 18, 181).

For a given paper there are critical acid concentrations, temperatures, and times of contact to be observed and several processes are intended to facilitate control of the conditions. Barrett, Foulds *et al.* (B.P. 200881), add 0.5-1.0% of formalin to the acid and in addition may employ two acid baths of different strengths, 74 and 56% (B.P. 230530; cf. B.P. 123594). The destructive action of the acid may also be retarded by dissolving in it pyridine (6.P. 433180) or an aminotriazine such as melamine (U.S.P. 2299200; cf. U.S.P. 2174534).

Thicker parchment paper used for making buttons is made by pressing together several layers while still wet with acid. For a collection of patents on parchmentising cellulose, see E. Sedlaczek, "Mercerisierungsverfahren," Berlin, 1928. See also J. T. Marsh, "Mercerising," London, 1941.

Recovery of waste acid by concentration may be preceded by addition of nitric acid and heating to 100°; organic matter in solution which would otherwise char is thus destroyed (U.S.P. 2069472; cf. G.P. \*18831).

*Properties.*—The standards proposed by Krup (Analyst, 1931, 56, 149; Amer. Chem. Abstr. 1931, 28, 2206) are: moisture content not greater than 10%, the wet strength at least 33% of the original strength, the ash should not exceed 0.45%, and the water-soluble extract 1-30%. Vegetable parchment containing a high extract is liable to attack by mould growth. Fortini *et al.* (J.S.C.I. 1913, 32, \*282) found 90-55% for the wet strength of genuine parchment paper; the corresponding figures for imitation parchment paper (see below) were 70-10%. Solechnik (Amer. Chem. Abstr. 1935, 29, 1244) estimates the degree of parchmentisation by measuring the transparency with a selenium photoelectric cell. A higher transparency results from a preliminary mercerisation with 18% sodium hydroxide and subsequent treatment with 80% sulphuric acid. The opacity of genuine parchment paper to the ultra-violet has a preservative function for packed foodstuffs (Sommer *et al.*, B. 1933, 620; Strachan and Davies, Chem. and Ind. 1934, 973). Commercial parchment papers differ in this respect, and greaseproof paper is not opaque (Schlemmer, Amer. Chem. Abstr. 1935, 29, 2611). An autocatalytic oxidation of butter fat may also be promoted by traces of metallic salts; 22 p.p.m. of copper and 50

p.p.m. of iron were found in parchment paper but these quantities did not accelerate the oxidation of butter fat in contact with the parchment (Strachan and Davies, *I.e.*).

The rate of transmission of aqueous vapour in both directions through the wrapping of food packages has been studied. Carson (*ibid.* 1937, 31, 8748) measured the permeability of packaging materials to water vapour and suggests a standard method. Oswin (J.S.C.I. 1945, 64, 67, 224) calculates a safety factor defining spoilage from the rate of transmission of aqueous vapour through the wrapping, but the result is criticised by Grover (Chem. and Ind. 1945, 175). The defect of brittleness in parchment paper is obviated by treating the paper with hygroscopic substances (Strachan, Food, 1933, 2, 187) which impart flexibility; these include calcium chloride, calcium propionate, magnesium chloride, glycerol, sugar. The two additions last-named favour the growth of moulds, while the salts should not be brought into contact with food (Burr, *et al.*, J.S.C.I. 1912, 31, 811; Strachan, *ibid.*).

Parchment paper is used as a wrapping for butter and other foods, for tobacco, as covers for jam jars, for sausage skins, etc.

"Pergamyn," "Glassine"—Imitation parchment paper is obtained by a mechanical process in which the paper pulp is beaten with blunt knives in a hollander until the fibres are swollen, fibrillate, and adhesive. Although of similar appearance the finished paper is not so water- and fat-resistant as the genuine product. Simple tests will detect the imitation: (1) observation of a transverse section in potash solution, the genuine being dark; (2) boiling a specimen in dilute sodium hydroxide solution, the imitation being disintegrated; (3) the wet bursting strength of the genuine is higher!

"Cellophane" (v. Vol. II, 442i) is a transparent film of regenerated cellulose made by the viscose process and widely used for packaging. This film and cellulose acetate film are described by M. Halama, "Transparentfolien," Berlin-Steglitz, 1932. In wet strength, viscose film is inferior to genuine vegetable parchment.

Vulcanised fibre, which has no relation to vulcanised rubber, is a modified paper in which the fibres have been gelatinised by contact with warm concentrated zinc chloride solution and then subjected to the coagulating effect of water. The process and plant resemble those in use for vegetable parchment with important differences. In the sulphuric acid process (see above) only two or three layers can be united before the mass pulp (Williams, J.S.C.I. 1921, 40, 224T). In the zinc chloride process many layers can be coalesced but a prolonged washing is necessary. The acid bath for vulcanised fibre may be 65% zinc chloride solution at 40° or a 70% solution at 35° and adjustments are made in the conditions according to the quality of paper used. The treated material is wound up on a large heated roller until of the desired thickness. It is then washed in tanks containing zinc chloride solutions of successively increasing dilution and finally in water. Sheets 1/2 in. in thickness require 2 months washing, 6-8 months for those of 2 inches. The washed product is dried at 40-

60°, pressed and calendered. The product is a very hard mass, grey unless the paper was coloured by incorporation of pigments, and can be worked with machine tools. Packing rings, travelling trunks, rovers for printing machines, etc., are made from the material, which has the disadvantage that it swells if immersed in water. Although a bad conductor of electricity it is not a reliable insulator.

Cuprammonium solution (v. Vol. III, 355a) parchmentises and rapidly dissolves cellulose (Mercer, B.P. 13296, 1850). Paper, rope or canvas may be immersed in cuprammonium solution until the outer fibres are gelatinised, and the material when dried is a green waterproof product, e.g., "Walesden canvas" (B.P. 3685, 1877; 185, 1878; 5054, 1894).

For further information on cellulose fibres, see P. H. Hermans, "Contributions to the Physics of Cellulose Fibres" (Elsevier Publishing Co., London, 1946), Haller, Amer. Chem. Abstr. 1146, 40, 4219.

-tj. JN S. VII  
"PARKERISING" (v. Vol. III, 392d; 493(2).

PARMOIME. A ketone, C<sub>14</sub>H<sub>20</sub>O. Occurs in oil from pölet flowers, phenylsemicarbazone, m.p. 166-168°, -p-bromophenylhydrazole, m.p. 132-133° (Buzicka, Compt. rend. Cong. Chim. Ind. 1937, 915). \*

J. L. S.  
PARSLEY (*Apium petroselinum* L.). A common garden herb much utilised in flavouring and garnishing. Agcaoili (Philippine J. Sci. 1916, 11, 91) records: Water 85.7, protein 3.82, Fat 1.39, nitr. 1.5, fibre 4.82, ash 2.75%. Petersoffi Elvehjem *et al.*, (quoted by A. L. and K. B. Winton, "Structure and Composition of Foods." New York, 1932-1939) state that parsley leaves contain a considerable proportion of iron (192 mg. per kg. fresh weight) and small amounts of copper (2.1 mg. per kg.). Leaves, stems, and seeds contain apiin (v. Vol. I, 450c), probably the glucoside of apigenin (v. Vol. II, 5206). Hydrolysis yields apiose, glucose, and apigenin. According to von Gerichten (Ber. 1900, 33, 2334) a luteolin monomethyl ether is also present in the leaves.

A. G. Po.  
PARSLEY, ESSENTIAL OIL OF. Parsley Oil. The characteristic components of parsley oils, of both the essential oil and the crude fatty oil (v. *infra*) are phenolic ethers of safrole. German parsley yields mainly *apiole*, 2:5 - dimethoxy - 3:4 - methylenedioxy - 1 - allylbenzene;

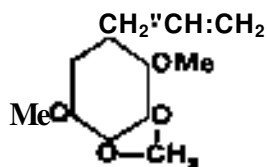

In Butch, English, and French parsley oils this compound is replaced by *myristicin*, 5-methoxy - 3:4 - methylenedioxy - 1 - allylbenzene. The German essential oil is often a semi-solid mass of *apiole* crystals, "parsley camphor." In French oil Thorns (Ber. 1908, 41, 2753) found a new ether, 2:3A:5-tetramethoxy-1-allyl-

*benzene*. Parsley fruit when distilled yields a colourless or yellow oil with an odour different from that of the herb. The constants of an English product were: yield 2.99%; p 1.061; n<sub>D</sub><sup>20</sup> 1.5168; opt. rotation -3.4°; solubility in 80% alcohol 1:3.5 (Matthews, Perf. & Essent. Oil Rec. 1940, 31, 60). A French oil contained a fraction giving the reactions of Z-pinene (Thorns, Ber. 1903, 36, 3453). The oil distilled from parsley leaves had: p<sub>16</sub> 0.911; [α]<sub>D</sub><sup>20</sup> +6.0°; n<sub>D</sub><sup>20</sup> 1.5029; acid. val. 1.4; sap. val. 10.3 (Guenther, B. 1937, 1407). "Apiolin" prepared by distilling the unsaponifiable portion of "Liquid. Apiol" (v. *infra*) had p 1.125; b.p. 280-3(K>>); sap. val. 0 (H. Thorns, "Pharmazie," Berlin, 1927, VI, i, 194). See also B.P.C. 1934, 728.

J. N. G.  
PARSLEY, FATTY OIL OF. *Apiol*. Oleoresin of Parsley Fruit is contained in a series of pharmaceutical preparations obtained by extracting parsley fruit with volatile solvents, a final purified product from German parsley being crystallised *apiole* (v. *supra*). The single extraction with alcohol, ether, or light petroleum yields mixtures of essential and fatty oils. Oleoresin of Parsley Fruit formerly in U.S.P. is a green oil obtained by extraction with ether and corresponds to "Green Apiol" (B.P.C. 1934, 145). Walmsley (Quart. J. Pharm. 1928, i, 388) found for this product: yield, 23.5%; p 0.9355; sap. val. 162.6 equivalent to 85% glycerides. It is purified by treatment with litharge and bone black to give "Yellow Liquid Apiol." "Liquid Apiol" is the alcohol-soluble fraction of a light petroleum extract. "Apiol" from extraction with 90% alcohol is a brownish-green mass, p 1.030; sap. val. 81.75. *Apiol* (v. *supra* "ESSENTIAL OIL OF PARSLEY") is prepared from "Green Apiol" of German origin by repeated crystallisation from alcohol; it forms needles, m.p. 30°; b.p. 294/760 mm. Soluble in organic solvents. Boiling with alcoholic potassium hydroxide gives *isoapiole* by conversion of the allyl into a propenyl group. Myristicin (u. *supra* "ESSENTIAL OIL OF PARSLEY") is a liquid, b.p. 149.5/15 mm.; p 1.1437; n<sub>D</sub><sup>20</sup> 1.5403; a similar conversion yields *isomyristicin*, m.p. 44°; b.p. 166°/18 mm.

The isomeric *apiole* in dill oil and oil of samphire is 5:6-dimethoxy-3:4-methylenedioxy-1-allylbenzene (A. 1909, i, 642; 1926, 3036).

Vongerichten *et al.* (J.C.S. 1909, 96, i, 454) isolated from the fat of parsley fruit a new fatty acid, *petroselic acid*, J<sup>6:7</sup>-octadecenoic acid, CH<sub>3</sub>[CH<sub>2</sub>]<sub>10</sub>CH=CH[CH<sub>2</sub>]<sub>4</sub>COOH, Hill-ditch *et al.* ft.S.C.I. 1927, 16, 174T) confirmed this observation. By extraction of English\* fruit with light petroleum they obtained 20.5% of fatty oil and 4.5% of non-fatty oil. The fatty acids were: *petroselic* 6%; *oleic* 15%; *linoleic* 67%. The non-fatty oil contained ca. 70% of phenolic ethers, at least 60% of myristicin; *apiole* was not identified. About 2% was found of the hydrocarbon wax, *petrosilane*, C<sub>20</sub>H<sub>42</sub>, m.p. 69° (Matthes *et al.* J.C.S. 1909, 96, ii, 754).

*Therapeutic Uses*.—Parsley oil and extracts of parsley fruit have been prescribed in dysmenorrhoea and as a diuretic. Preparations such as green and yellow *apiols*, *apolin*, fractions of

parsley oil exerted similar physiological and toxic actions. Myristicin is less active and less toxic, see Lutz and Oudin, Chem. Zentr. 1909, I, 1254; Lutz, *ibid.* 1910, I, 1275; Chevalier, *ibid.* 1910, I, 1799; Christomanos, Amer. Chem. Abstr. 1928, 22, 276; Patoir *et al.* A. 1935, 1533; Frappi, Amer. Chem. Abstr. 1936, 30, 164; Marri, *ibid.* 1939, 33, 7893. The efficacy of apiole preparations has been questioned in U.S.D. 22nd ed., 1937, 1509; they are not included in the British or American Pharmacopoeias.

**Adulteration and Poisoning Effects.**—There has been widespread adulteration of apiole chiefly with the toxic substance tri-o-cresyl phosphate (Extra Pharm. 1941, i, 2c2; Brit. Med. J. 1933, ii, 579) which causes polyneuritis; see von Itallie, Amer. Chem. Abstr. 1932, 26, 5336; Kalbfleisch, A. 1933, 1078; Tiffeneau, Amer. Chem. Abstr. 1934, 28, 1774; Herrmann, *ibid.* 1934, 28, 6248.

**Detection and Determination.**—Lespagnol *et al.* (*ibid.* 1942, 36, 1388; 1945, 39, 5269) detect apiole in body fluids by a modification of Labat's colour reaction (J.C.S. 1909, 96, ii, 710, 771). According to Walmsley (*l.c.*) the test is unreliable. Apiole may be determined by a titration method with bromide-bromate (Vignoli, Chem. Zentr. 1933, II, 1728). Windisch (*ibid.* 1934, II, 1171) separates the components as tribromoapiole, m.p. 118-120°, and tribromomyristicin, m.p. 126-129°. King (Analyst, 1929, 54, 567) determines apiole by a modified Zeisel method. Tri-o-cresyl phosphate is detected by saponifying, acidifying, extracting the cresol for identification with ether, and testing the aqueous portion for phosphoric acid. An unstable form of apiole, m.p. 18-19°, was obtained by supercooling (A. 1930, 846).

J. N. G.

**PARSNIP** (*Pevcedanum sativum* Benth. and Hook, or *Pastinaca sativa* L.). An umbelliferous fleshy-rooted vegetable in common use in temperate climates for domestic purposes. It is frequently grown in some districts as a winter food for cattle and horses. Typical recorded analyses are:

Whole root	Water.	Protein.	Fat.
Edible portion	800	22	0.4
	83.2	1.6	0.4

	Nitrogen-free			
	Sugar,	extract.	Fibre.	Ash.
Whole root	14.8		3.6	1.0
Edible portion	2.3	8.1	1.3	1.8

The improved flavour of parsnips following exposure to frost is attributed by Boswell (Maryland Agric. Exp. Sta. 1923, Bull. 258) to stimulated hydrolysis of starchy matter to sugar initiated during thawing. The ash of parsnips is notably rich in potassium. Haskins (Massachusetts Agric. Exp. Sta. Spec. Bull. 1919) quotes the following mineral analysis as percentage of the fresh weight of the root: H<sub>2</sub>O 80.3, K<sub>2</sub>O 0.62, Na<sub>2</sub>O 0.01, CaO 0.09, MgO 0.05, P<sub>2</sub>O<sub>5</sub> 0.19%. Peterson, Elvehjem *et al.* (quoted by A. L. and K. G. B. Winton, "Structure and Composition of Foods," New York, 1932-1939), record iron 10.7 and copper 1.2 mg. per kg. of fresh parsnip root.

The vitamin-C content of parsnips averages, in November, 1.5-3.0 and after storage until February 2-18 mg. per 100 g.

A. G. Po.

**PARTIAL MOLAR QUANTITIES.**—Physicochemical properties of systems are of two kinds, intensive and extensive. The magnitude of intensive properties does not depend on the amount of matter in the system; the magnitude of extensive properties does. Temperature (*T*), pressure (*P*), density (*p*), compressibility (*θ*), and viscosity (*TJ*) are instances of intensive properties. Volume (*F*), energy (*E*), heat content (*H*), free energy (*A*), and Gibbs energy (*O*) are examples of extensive properties. When, to any system, however complicated, a gram-molecule of any of its component species is added, the magnitude of all the extensive properties of that system is altered. The increase in the magnitude of any given extensive property of a large system caused by the addition, at constant temperature and pressure, of one gram-molecule of any component is termed the *partial molar quantity*.

Let this property concerned be denoted by *X*, and let it be assumed that *X* for the whole system is a function of its temperature, its pressure, and of the numbers *n*<sub>1</sub>, *n*<sub>2</sub>, *n*<sub>3</sub>, . . . of gram-molecules of the various components. Then

$$X = f(T, P, n_1, n_2, n_3, \dots) \quad (1)$$

Any change in *X* may be formulated as follows:

$$\left. \begin{aligned} dX &= (\partial X / \partial T)_{P, n_1, n_2, n_3, \dots} dT \\ &+ (\partial X / \partial P)_{T, n_1, n_2, n_3, \dots} dP \\ &+ (\partial X / \partial n_1)_{T, P, n_2, n_3, \dots} dn_1 \\ &+ (\partial X / \partial n_2)_{T, P, n_1, n_3, \dots} dn_2 + \dots \end{aligned} \right\} (2)$$

In particular, any change in *X* at constant temperature and pressure (when *dT*=0 and *dP*=0) may be formulated as follows:

$$\left. \begin{aligned} dX &= (\partial X / \partial n_1)_{T, P, n_2, n_3, \dots} dn_1 \\ &+ (\partial X / \partial n_2)_{T, P, n_1, n_3, \dots} dn_2 \\ &+ (\partial X / \partial n_3)_{T, P, n_1, n_2, n_4, \dots} dn_3 + \dots \end{aligned} \right\} (3)$$

To save space the subscripts, denoting constancy of temperature and pressure will be omitted, but should not be forgotten. Then

$$\left. \begin{aligned} dX &= (\partial X / \partial n_1)_{n_2, n_3, \dots} dn_1 \\ &+ (\partial X / \partial n_2)_{n_1, n_3, \dots} dn_2 \\ &+ (\partial X / \partial n_3)_{n_1, n_2, n_4, \dots} dn_3 + \dots \end{aligned} \right\} (4)$$

But, by definition, each partial differential coefficient stands for the partial molar value of *X* with respect to the component the amount of which is varied, and may be denoted thus:

$$\begin{aligned} \bar{X}_1 &= (\partial X / \partial n_1)_{n_2, n_3, \dots} \\ \bar{X}_2 &= (\partial X / \partial n_2)_{n_1, n_3, \dots} \end{aligned} \quad (5)$$

Hence

$$dX = \bar{X}_1 dn_1 + \bar{X}_2 dn_2 + \bar{X}_3 dn_3 + \dots \quad (6)$$

This expression may be integrated from zero values of *n*<sub>1</sub>, *n*<sub>2</sub>, *n*<sub>3</sub>, . . . and consequently from a zero value of *X*, to final values *n*<sub>1f</sub>, *n*<sub>2f</sub>, *n*<sub>3f</sub>, . . .

while the ratios  $n_1:n_2:\dots:k$  are maintained constant during the integration. Because of this stipulation of constancy of composition, the various partial molar magnitudes  $\bar{X}_1, \bar{X}_2, \dots$  also remain constant throughout; and we obtain

$$X = \bar{X}_1 n_1 + \bar{X}_2 n_2 + \bar{X}_3 n_3 + \dots \quad (7)$$

From this equation, we see that  $\bar{X}_1$  is the magnitude of  $X$  which we must ascribe to one gram-molecule of the species 1 in order to be able to express the total magnitude of the property  $X$  for the system on a molar additivity basis. Let us now differentiate equation (7) without imposing the artificiality required for its derivation. Then

$$dX = \bar{X}_1 dn_1 + n_1 d\bar{X}_1 + \bar{X}_2 dn_2 + n_2 d\bar{X}_2 + \dots \quad (8)$$

By subtracting this expression from equation (6), the formula of Gibbs and J<sub>h</sub>em is obtained:

$$n_1 d\bar{X}_1 + n_2 d\bar{X}_2 + n_3 d\bar{X}_3 + \dots = 0 \quad (9)$$

Let the total number of gram-molecules in the system be denoted by  $n$ :

$$n = n_1 + n_2 + n_3 + \dots \quad (10)$$

and the molar fractions,  $x$ , of the various components then become

$$\begin{aligned} x_1 &= n_1/n, \\ x_2 &= n_2/n, \\ &\dots \end{aligned} \quad (11)$$

The molar value of the property  $X$  for the system as a whole is denoted as

$$\bar{X} = X/n \quad \dots \quad (12)$$

It is the molar value of the property in question possessed by a system which contains, in all, one gram-molecule of substance. Equation (7) may now be written in terms of molar fractions:

$$X = x_1 \bar{X}_1 + x_2 \bar{X}_2 + \dots \quad (13)$$

'Methods of Determining Partial Molar Quantities.—Many methods have been used to measure the partial molar quantities of the various components in complicated systems. When the property  $X$  can be expressed analytically as some simple algebraic function of the numbers of gram-molecules of components\* such, for example, as follows:

$$\begin{aligned} X &= a_1 n_1 + b_1 n_1^2 + c_1 n_1^3 \\ &+ a_2 n_2 + b_2 n_2^2 + c_2 n_2^3, \dots \end{aligned} \quad (W)$$

equation (5) gives:

$$\bar{X}_1 = a_1 + 2b_1 n_1 + 3c_1 n_1^2$$

and  $\bar{X}_2 = a_2 + 2b_2 n_2 + 3c_2 n_2^2 \dots \quad (15)$

This<sup>1</sup> is the form in which the partial molar heat contents of solutes in aqueous solution have generally been recorded. A second analytical method, making use of the conception of an apparent molar quantity, is described in a later section, dealing with specific heat\*. In the absence of an analytical expression,  $X$  for the system may be represented graphically\* as separate functions of the numbers of gram-molecules of the various components, when  $X$  is a function of  $n_1$  and  $n_2$  directly as the tangent.

The problem is naturally much simpler in systems of only two components, to which the

general method of intercepts may easily be applied. Let  $x$  stand for the molar fraction of component 1, so that  $(1-x)$  is the molar fraction of component 2. Equation (13) thus becomes

$$\begin{aligned} \bar{X} &= \bar{X}_1 x + \bar{X}_2 (1-x) \\ &= \bar{X}_2 + (\bar{X}_1 - \bar{X}_2)x \end{aligned} \quad (16)$$

The gradient at any point on the curve (Fig. 1) is

$$\left(\frac{\partial \bar{X}}{\partial x}\right) = \bar{X}_1 - \bar{X}_2 \quad \dots \quad (n)$$

The value of  $\bar{X}$  corresponding to the intercept  $x=0$  is found by subtracting from the value given by equation (16) the increment  $(\bar{X}_1 - \bar{X}_2)x$ . Similarly the value of  $\bar{X}$  corresponding to the intercept  $x=1$  is found by adding to the value given by equation (16) the increment  $(\bar{X}_1 - \bar{X}_2)(1-x)$ . These facts are made clear

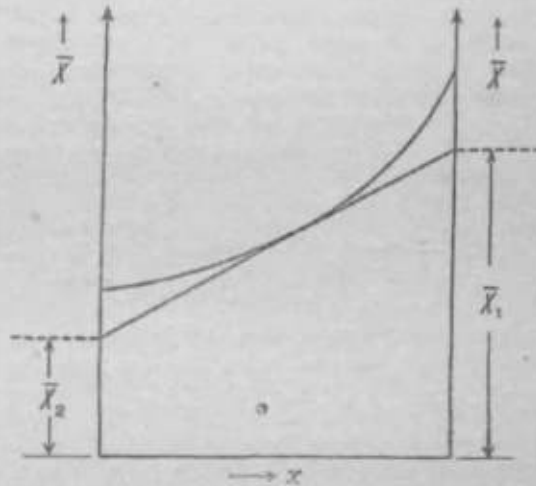

FIG. 1.—THE DETERMINATION OF PARTIAL MOLAR QUANTITIES FOR BINARY SYSTEMS BY THE METHOD OF INTERCEPTS.

from an inspection of the straight line in Fig. 1. We have, then,

$$\bar{X}(x=0) = \bar{X}_2$$

and  $\bar{X}(x=1) = \bar{X}_1 \quad \dots \quad (18)$

This convenient method is the one generally employed in dealing with binary systems.

Partial Molar Volumes.—Suppose that the weight per cent.,  $w$ , and density,  $\rho$ , of a binary liquid system of various compositions are given. In handling the data, it is necessary to fix the mind's eye on a given quantity of the system. What quantity is immaterial; so long as 100 g. is kept in mind in all cases. If  $w$  refers to component 1, and if  $M_1$  is its molecular weight, then the number of gram-molecules in our 100-g. system is

»

The number of gram-molecules of the second component is obviously

$$n_2 = (100-w)/M_2 \quad \dots \quad (20)$$

The volume of the 100-g. system is clearly  $100/\rho$ ; hence the molar volume of the system is

$$\bar{V} = 100/(n_1 + n_2)\rho \quad \dots \quad (21)$$



The molar fraction of the first component is, by definition,

$$x_1 = \frac{n_1}{n_1 + n_2} \quad (22)$$

These conclude the algebraic steps. Values of  $V$  must now be computed for all values of  $x_1$  varying from 0 to 1.  $V$  is now plotted as a function of  $x_1$  and the partial molar volumes of both components are obtained as the two intercepts made by the tangents. An example is afforded in Table I and Fig. 2. That the partial

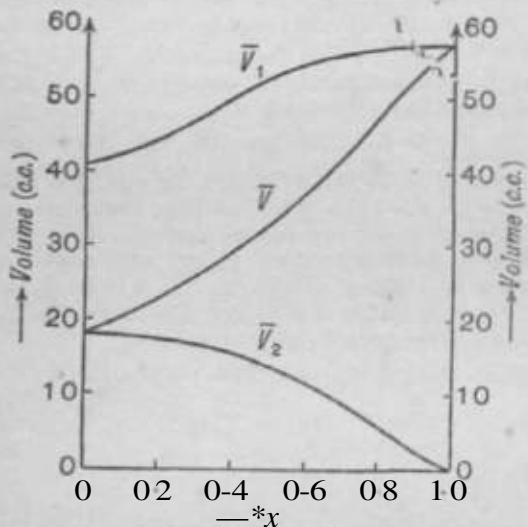

FIG. 2.—THE PARTIAL MOLAR VOLUME OF PERCHLORIC ACID (ADD THE PARTIAL MOLAR VOLUME OF WATER;  $V_2$ ) AT 15°C.

The middle curve shows the molar volume ( $\bar{V}$ ) of the solution,  $x$  is the molar fraction of the acid.

molar volume of water in the pure electrolyte should be zero is a mere accident. Partial molar volumes may well be negative, as some of the figures in Table II indicate.

TABLE I.—PARTIAL MOLAR VOLUME (IN C.C.) OF WATER AND PERCHLORIC ACID AT 15°C.

$x_1$	$\bar{V}$	$\bar{V}_1$	$\bar{V}_2$
0	180	40.9	1802
0.1	20.4	42.5 *	17.7
0.2	22.9	44.3	17.5
0.3	25.9	47.2	16.8
0.4	28.9	49.5	15.2
0.5	33.0	62.5	13.5
0.6	37.2	54.2	11.8
0.7	41.6	55.4	9.5
0.8	47.5	66.1	5.9
0.9	52.9	66.85	2.6
1.0	56.9	56.9	0

Neither a zero nor a negative partial molar volume is difficult to understand. Zero volume may indicate that the component concerned dissolved by fading nooks and crannies in the structure of the other component, into which it enters without influencing it. This is the behaviour one would rather expect when small molecules dissolve among large molecules. The

clue to the negative partial molar volumes is provided by the fact that they are prone to appear with highly charged cations. The Coulomb field exerted by these ions is strong, and they draw to themselves water molecules, which they orient radially and bind firmly. Such a bound and clamped water molecule naturally occupies less volume than a free water molecule. It is merely the algebra of the thermodynamical treatment that makes the contraction of the solvent appear as a negative volume attributed to the solute. Other factors, of course, enter, and to these some reference is made in a later section.

TABLE II.—THE PARTIAL-MOLAR VOLUMES OF CERTAIN ELECTROLYTES IN INFINITELY DILUTE AQUEOUS SOLUTION AT 25°C.

Electrolyte.	$T^\circ$ (Observed).	$V^\circ$ (computed).
HCl . . . . .	18.2	18.2
LiCl . . . . .	17.1	17.1
NaCl . . . . .	16.3	16.3
KCl A . . . . .	26.4	26.4
KF . . . . .	6.7	6.7
LiOH . . . . .	-6.0	-6.1
NaOH . . . . .	-6.7	-6.9
KOH . . . . .	2.9	3.2
BaCl <sub>2</sub> . . . . .	23.1	23.6
CaCl <sub>2</sub> . . . . .	18.3	18.3
HClO <sub>4</sub> . . . . .	41.1	41.1

It is the normal practice of the physical chemist to split up properties found for "one" ion in an electrolyte into separate values for both. This practice was initiated by Kohlrausch. Possible, but by no means final, values of the partial molar volumes of certain ions in water at great dilutions are shown in Table III. The volumes given in the last column of Table II have been obtained by addition of the partial ionic volumes.

TABLE III.—THE PARTIAL MOLAR VOLUMES (IN C.C.) OF IONS AND SIMPLE MOLECULES IN INFINITELY DILUTE AQUEOUS SOLUTION AT 25°C.

Solute.	$\bar{V}^\circ$	Salute.	$\bar{V}^\circ$
H <sup>+</sup> . . . . .	50	F <sup>-</sup> . . . . .	-6.5
Li <sup>+</sup> . . . . .	3.9	Cl <sup>-</sup> . . . . .	13.2
Na <sup>+</sup> . . . . .	31	OH <sup>-</sup> . . . . .	-10.0
K <sup>+</sup> . . . . .	13.2	ClO <sub>4</sub> <sup>-</sup> . . . . .	36.1
Ba <sup>++</sup> . . . . .	-2.8	CO(NH <sub>2</sub> ) <sub>2</sub> . . . . .	44.3
Ca <sup>++</sup> . . . . .	-8.1		210.0

The Inter-relationship of Partial Molar Quantities.—The thermodynamic formula used for systems of one component, such, for example,

$$G = H - TS, \quad (23)$$

$$O_p = (dH/dT)_p, \quad (24)$$

$$V = (dG/dP)_T, \quad (25)$$

$$S = -(dG/dT)_p, \quad (26)$$

and

may be applied, *mutatis mutandis*, to partial molar quantities. Thus

$$Q = \bar{H}_i - T\bar{B}_i \quad (27)$$

$$\bar{G}_1 = -\left(\frac{d\bar{F}_1}{dT}\right)_P \quad (28)$$

$$\bar{V}_1 = \left(\frac{d\bar{G}_1}{dP}\right)_T \quad (29)$$

and

$$\bar{S}_1 = -\left(\frac{d\bar{G}_1}{dT}\right)_P \quad (30)$$

The partial molar quantities which have been investigated with the greatest thoroughness are those relating to aqueous solutions of electrolytes, and to some of them we accordingly apply the following formula.

**Partial Molar Properties of Electrolytic Solutes.**—A solution, of total volume,  $V_0$  at temperature,  $T$ , and at atmospheric pressure, may be considered to contain  $N_1$  ions, with radius  $r_1$  and charge  $e_1$ ,  $N_2$  ions with radius  $r_2$  and charge  $e_2$ , and generally  $N_i$  ions with radius  $r_i$  and charge  $e_i$ . We denote the dielectric constant of the medium by the letter  $\epsilon$ . The partial Gibbs energy (not the partial molar Gibbs energy) of the ions may be represented by the equation:

$$\bar{G}_i = \bar{G}_i^\circ + \epsilon N_i \left[ \frac{e_i^2 T}{2D r_i} + \left( \frac{e_i^2}{2D r_i} \right) - \left( \frac{e_i^2 K}{3D} \right) \right] \quad (31)$$

where the ionic concentration, in ions per c.c. is  $m^* = N_i/V_0$  . . . . . (32)

and  $K = \epsilon^2 / DhT$  . . . . . (33)

The three terms in the brackets are associated with the names of van't Hoff, Born, and Debye, respectively. The first term represents the energy which is possessed by all freely moving particles,  $\bar{G}_i^\circ$  (her in the gas phase of in solution. The second term is the electrostatic energy possessed by a sphere of charge  $e$  and radius  $r$  in a medium of uniform dielectric capacity,  $D$ . The last term is the diminution in electrostatic energy due to the presence around each ion of ions with opposite charges. The remaining term,  $\theta^\circ$ , is clearly the Gibbs energy of the uncharged particles when at unit concentration ( $m^* = 1$ ), and arises in part from internal motions and in part from interaction with the solvent.

On applying equations (30), (29), and (27), we obtain the formulae:

$$\bar{S}_i = \bar{S}_i^\circ - \epsilon N_i \left[ \frac{e_i^2 T}{2D r_i} + \left( \frac{e_i^2}{2D r_i} \right) + \left( \frac{e_i^2 K}{3D} \right) (1 - 3\epsilon T + \epsilon T^2) \right] \quad (34)$$

$$\bar{V}_i = \bar{V}_i^\circ + \epsilon N_i \left[ \frac{e_i^2}{2D} - \left( \frac{e_i^2}{2D r_i} \right) \left( \frac{d \ln D}{dP} \right)_T + \left( \frac{e_i^2 K}{2D} \right) \left[ \left( \frac{d \ln D}{dP} \right)_T - \beta / \epsilon \right] \right] \quad (35)$$

and

$$\bar{H}_i = \bar{H}_i^\circ + \epsilon N_i \left[ \frac{e_i^2 T}{2D} + \left( \frac{e_i^2}{2D r_i} \right) (1 - \epsilon T) - \left( \frac{e_i^2 K}{2D} \right) (1 - \epsilon T + \frac{1}{2} \epsilon T^2) \right] \quad (36)$$

where

$$\alpha = (1/V) \left( \frac{dV}{dT} \right)_P \quad (37)$$

$$L = -(UD) \left( \frac{dD}{dT} \right)_P \quad (38)$$

and

$$\beta = -(1/V) \left( \frac{dV}{dP} \right)_T \quad (39)$$

When we represent the total number of ions from one gram-molecule of the electrolyte, these terms are partial molar quantities. They are extensive quantities.

**Partial Molar Specific Heats and the Concept of Apparent Molar Specific Heats.**—The following considerations refer to systems at

constant pressure, but the subscript, as in previous passages, is omitted. The amount of heat,  $C$ , required to bring about an increase in temperature of one degree in a system containing 1,000 g. of solvent and  $m$  gram-molecules of solute, may be referred to as the heat capacity of the solution of molarity  $m$ . Further, let

$\bar{c}_1$  = the partial molar heat capacity of the solvent,

$\bar{c}_1^\circ$  = the value of  $\bar{c}_1$  when  $m$  is zero,

$c_2$  = the partial heat capacity of the solute =  $(dC/dm)_1$

and  $c_2^\circ$  = the value of  $c_2$  when  $m$  is zero.

A directly measurable quantity,  $\Phi$ , may now be defined by the equation

$$\Phi = \{G - (l_0 miM) c^\circ\} / lm \quad (40)$$

$\Phi$  is seen to be the difference between the heat capacity,  $C_0$  of the system and the heat capacity of the pure solvent (of molecular weight  $M$ ), divided by the number of gram-molecules of solute in 1,000 g. of solvent. It is termed the apparent molar heat capacity. On differentiating with respect to  $m^{1/2}$ , we obtain:

$$\frac{d\Phi}{dm^{1/2}} = 2m^{1/2} \left[ \left( \frac{1}{m} \right) \left( \frac{dC}{dm} \right) - \left( \frac{1}{m_2} \right) \right] - \left[ \frac{2}{m^{1/2}} \right] (\bar{c}_2 - \Phi) \quad (41)$$

Hence

$$\bar{c}_2 = \Phi + (m^{1/2}) \left( \frac{d\Phi}{dm^{1/2}} \right) \quad (42)$$

The value of  $\theta$  corresponding to a zero value of  $m$  is identical with  $\bar{c}_2^\circ$ , which is the partial molar specific heat of the solute at infinite dilution. Some experimental values are shown in Table IV.

TABLE IV.—PARTIAL MOLAR SPECIFIC HEATS,  $\bar{c}_2^\circ$ , OF CERTAIN ELECTROLYTES AT INFINITE DILUTE IN WATER AT 25°C. (G.-CAL. PER Q.-MOL. PER DEGREE).

Solute.	$\bar{c}_2^\circ$ .	Solute.	$\bar{c}_2^\circ$ .
NaCl	-23.3	KCl	-28.5
NaBr	-24.5	KBr	-29.7
NaI	-24.8	KI	-30.4
NaNO <sub>3</sub>	-1.20	KNO <sub>3</sub>	-17.2
Na <sub>2</sub> SO <sub>4</sub>	-50.0	K <sub>2</sub> SO <sub>4</sub>	-60.6

**The Chemical Potential.**—The most important of the many partial molar quantities is the partial molar free energy or the partial molar Gibbs energy. This is defined by either of the relations

$$\mu = \left( \frac{dA}{dN} \right)_T, P, n_2, n_3, \dots \quad (43)$$

or  $f_i^{ss} (dD/dN)_{j, p, n, T, \dots} \quad (44)$

and is known, for the sake of brevity, as the chemical potential. Its importance lies in that this is the property of molecular species which determine their equilibrium relationships. Chemical equilibrium results when

$$f_i (\text{reactants}) = f_j (\text{resultants}) \quad (45)$$

and physical equilibrium when

$$H (\text{one phase}) = H (\text{second phase}) \quad (46)$$

For the purpose of establishing the formal laws of equilibrium, it is sufficient to relate the free energy of a given species under given conditions to the free energy of the same species under other conditions. The most popular formula of this type is

$$A = A^\circ + XkT \ln \dots \quad (47)$$

With the advent of the quantum theory, however, a more thorough-going treatment of equilibria has become possible. Formulae of the type of equation (47) naturally emerge again, but the term  $A^\circ$  is no longer simply "the free energy in the standard state". It can be evaluated absolutely in terms of properties accessible to measurement under conditions not related to equilibrium conditions. A very simple example will serve to illustrate the relation between the partial molar free energy, or the chemical potential, and the partition function (this Vol., p. 244c).

The partition function for a gas molecule of mass  $m$  in a system containing  $N$  molecules in a volume  $V$  and at a temperature  $T$  is

$$f = \left( \frac{2\pi m kT}{h^2} \right)^{3/2} \frac{V}{N} \dots \quad (48)$$

In an ideal mixture of gases, containing  $N_1$  molecules of one kind and  $N_2$  molecules of another kind in a total volume  $V$ , we have, by the multiplicative rule for independent partition function, the following expression for the grand partition function of the system :

$$F_{1,2} = f_1^{N_1} \times f_2^{N_2} = \left[ \left( \frac{2\pi m_1 kT}{h^2} \right)^{3/2} \frac{V}{N_1} \right]^{N_1} \times \left[ \left( \frac{2\pi m_2 kT}{h^2} \right)^{3/2} \frac{V}{N_2} \right]^{N_2} \dots \quad (49)$$

Here

$$v_1 = V/N_1 \dots \quad (50)$$

and

$$v_2 = V/N_2 \dots \quad (51)$$

The free energy of the system is

$$kT \ln F_{1,2} = -N_1 kT \ln \left[ \left( \frac{2\pi m_1 kT}{h^2} \right)^{3/2} \frac{V}{N_1} \right] - N_2 kT \ln \left[ \left( \frac{2\pi m_2 kT}{h^2} \right)^{3/2} \frac{V}{N_2} \right] \dots \quad (62)$$

and the pressure is

$$P = \left( d \ln F_{1,2} / dV \right)_{T, N_1, N_2} = (N_1 kT/V) + (N_2 kT/V) = P_1 + P_2 \dots \quad (53)$$

which is Dalton's law. By definition, the Gibbs energy is

$$G_{1,2} = A_{1,2} + PV = A_{1,2} + (P_1 + P_2)V = A_{1,2} + (N_1 + N_2)kT.$$

Hence

$$G_{1,2} = -N_1 kT \ln \left[ \left( \frac{2\pi m_1 kT}{h^2} \right)^{3/2} \frac{V}{N_1} \right] - N_2 kT \ln \left[ \left( \frac{2\pi m_2 kT}{h^2} \right)^{3/2} \frac{V}{N_2} \right] \dots \quad (54)$$

$V$  in this expression may now be replaced by its equivalent:

$$V = (N_1 + N_2)kT/P \dots \quad (55)$$

We then have

$$G_{1,2} = -N_1 kT \ln \left[ \left( \frac{2\pi m_1 kT}{h^2} \right)^{3/2} \frac{kT}{P} \right] - N_2 kT \ln \left[ \left( \frac{2\pi m_2 kT}{h^2} \right)^{3/2} \frac{kT}{P} \right] \dots \quad (55)$$

The chemical potentials, from equation (44), thus become

$$\mu_1 = -kT \ln \left[ \left( \frac{2\pi m_1 kT}{h^2} \right)^{3/2} \frac{kT}{P} \right] \left\{ \frac{(N_1 + N_2)}{N_1} \right\}$$

and

$$\mu_2 = -kT \ln \left[ \left( \frac{2\pi m_2 kT}{h^2} \right)^{3/2} \frac{kT}{P} \right] \left\{ \frac{(N_1 + N_2)}{N_2} \right\}$$

We note that

$$G_{1,2} = N_1 \mu_1 + N_2 \mu_2 \dots \quad (57)$$

as required, and that the chemical potential of either component may be expressed in the form :

$$\mu_i = \mu_i^\circ + RT \ln x_i \dots \quad (58)$$

where  $x_i$  is its molar fraction. This equation is the starting point for most of the current theories of homogeneous binary systems.

References.

J. V. Butler, "The Fundamentals of Chemical Thermodynamics," Part II, University of Illinois Press, Urbana, 1938.  
 B. C. Tolman, "The Principles of Statistical Mechanics," Oxford, 1938.  
 Randall and Rossini, J. Am. Chem. Soc. 1929, 51, 823.  
 Lunge and Robinson, Chem. Review\*, 1031, 9, 89.  
 Junker, ibid. 1933, 13, 111.

E. A. M.-H.

PARTICLE SIZE IN THE SUB-SIEVE RANGE, MEASUREMENT OF.

The rapid growth of interest in particle-size measurement is well shown in the scientific literature of recent years. Among the most important purposes for which particle size analyses are required the following may be mentioned :

1. The assessment of occupational health hazards due to air-borne dust.
2. The evaluation of the quality of a wide range of industrial products, such as pigments, cement, metal powders, flour, cocoa, and pulverised coal.
3. Its connection with ore degradation.
4. The study of coal cleaning.
6. The examination of soils.

The methods of determining particle size are numerous. In a particular case the choice of method depends in great measure upon the nature of the material and upon the circumstances which attend its application. Only in comparatively rare cases is it possible to measure the true particle size; in many instances, indeed, it is the effective size of a certain characteristic agglomeration of particles which is really needed.

As is well recognised, with diminishing particle size the tendency to agglomeration increases. In such a case, therefore, as that of a pigment, particle size should preferably be measured in conditions which approximate as closely as possible to those under which the material will be used. It should be conceded, however, that "ultimate" particle size is not merely of academic interest, for upon it depends, to a great extent, what is, in practice, one of the most important properties of a powder, the degree to which it will exhibit a tendency towards agglomeration.

Usually, powders and dusts are composed of

particles of different sizes. Some of the available methods of size analysis will yield information as to the distribution of the particles on a number, area or weight basis, while others give only the "specific surface" (area per unit mass or volume) or the derived "surface mean diameter."

The majority of the available methods of determining particle size fall into one of the five following classes:

- (a) Microscopical examination.
- (b) Sedimentation analysis.
- (c) Adsorption measurements.
- (d) Measurement of permeability of a packed bed.
- (e) Turbidimetric measurements.

MEASUREMENT OF PARTICLE-SIZE DISTRIBUTION.

(a) Microscopical Examination.—(i) *Direct-view and Photographic-projection Microscope*.—Size analysis by means of the microscope is one of the most direct methods available and is very widely used, both for the routine testing of industrial powders and for the examination of atmospheric dust. Usually, the particles are counted and each is assigned to one of a number of convenient size grades by reference to a suitable graticule contained in the eyepiece. With irregularly shaped particles, some confusion exists as to which dimension should be measured. While Fairs<sup>11</sup> advocates the use of the mean projected diameter, Schweyer and Work (p. 4)<sup>12</sup> state that the shorter of the two visible dimensions is a suitable one for measurement. If desired, the numerical distribution obtained directly may be converted to a mass basis by multiplying the number in each size range by a factor proportional to the mean of the cubes of the size limits of the range. If this conversion is made, it is more important than ever that the diameter chosen should be, as nearly as possible, representative of the volume of the particles. Unless the geometrical characteristics of the particles is known, which is in general unlikely, the weight distribution is liable to be inaccurate, especially if large "particles are present. It is generally held, however, that errors due to shape diminish as the size is reduced. Another difficulty which arises if the range of sizes present is too great, is that it becomes necessary to count at many different depths of focus. This can be overcome by previous division of the sample into size grades, but this obviously increases the time taken up by the analysis. The lower limit of size which can be resolved by the ordinary microscope, with oil-immersion lenses, and using light of 0.5  $\mu$ . wave-length, is about 0.2  $\mu$ . It is, however, only possible to approach this limit when the optical equipment is of the highest quality.

Most workers agree that the technique of size analysis by the microscope is tedious. Fairs<sup>11</sup> stresses the advantages, in improving accuracy and reducing eye-strain, which attend the use of monochromatic light. Photographic and projection methods are favoured by many workers who use the microscope technique for routine size analysis.

In using microscopical methods it is of the greatest importance that the sample examined should be truly representative. This presents no problem when special instruments, such as the thermal precipitator, are used for sampling atmospheric dusts. In other cases, it is customary to subdivide the bulk sample until a reasonable quantity, say 0.5 g., is obtained. This is then dispersed in melted glycerine jelly (or other suitable medium) and a small quantity taken for the preparation of the slide. Should it prove impracticable to disperse the powder by this method, it may be necessary to use an aqueous or other liquid medium, and examine in a haemocytometer cell.<sup>11</sup>

(ii) *The Ultramicroscope*.—The ultramicroscope has been used by Gehman and Morris<sup>13</sup> to extend the lower limit of the analysis down to 0.1  $\mu$ . An interesting application is that of Green<sup>15</sup> who has used the ultramicroscope to establish the virtually absolute efficiency of the thermal precipitator.

(iii) *The Electron Microscope*.—The resolving power of the electron microscope is at least twenty times as great as that of the ultramicroscope. It is thus possible, according to Hillier (p. 90),<sup>12</sup> to attain a lower size limit of 5 m $\mu$ , and further, to determine the actual size distribution between this and an upper limit of 1  $\mu$ . This technique is in the early stages of development, but there is no doubt that a very valuable new method is now becoming available for the study of ultra-fine powders, such as pigments and carbon blacks.<sup>3,14</sup>

(b) Sedimentation Analysis.—All sedimentation methods of size analysis make use of Stokes' law for the fall of particles through a fluid medium. The law is commonly expressed in the form

$$d = 10^4 \sqrt{\frac{18\eta v}{g(\sigma - \rho)}}$$

where  $d$  is Stokes' diameter in microns,  $v$  the terminal velocity in cm. per sec,  $\eta$  the viscosity of fluid in poises,  $\sigma$  the particle density in g. per c.c.,  $\rho$  the fluid density in g. per c.c., and  $g$  the acceleration due to gravity in dynes per cm.

The terminal velocity of a small particle is quickly attained, and hence its measurement (usually by determining the time required for a fixed height of fall) enables the size to be calculated. In a powder the particles are rarely perfectly spherical, and therefore size is expressed by the imaginary Stokes' diameter, *i.e.*, the diameter of a sphere of equal density, having the same settling rate as the particle.

The most direct application of this principle to size analysis is in the highly refined apparatus of Carey and Stairmand.<sup>7</sup> These workers have measured the actual paths taken by individual "particles from photographs of a settling suspension in a liquid medium. The more usual methods, which require less elaborate apparatus, treat the particles collectively. If an initially uniform suspension of particles of varying sizes in a fluid is considered, then at a definite height from the top of the suspension, the particles will remain in their original concentrations until sufficient time has elapsed for all the largest sizes to have fallen below the reference level. Measurement of the particle concentrations at

this level, after a number of predetermined time intervals, for each of which the limiting Stokes' diameter is calculated, is thus made to yield the size distribution of the original dispersion. This is the basis of all the so-called *incremental* methods of sedimentation analysis. In *cumulative* methods, on the other hand, the total amount of the dispersoid reaching a definite level, or alternatively, the total amount remaining above this level, at different time intervals, is measured. It will be evident that not only particles of the limiting size, which start from the top of the suspension, but also smaller ones falling a smaller distance, are measured together. The plot of the total weight settled against time, treated by Oden's method of tangential intercepts (p. 67),<sup>42</sup> gives the requisite "underrize" data.

Stokes' law is valid for Reynolds numbers not exceeding 0.2, and therefore is applicable to practically all particles, at the lower limit of the sieve range, in liquid media, although a correction is sometimes necessary if air be used.<sup>19</sup> The lower limit to which sedimentation methods apply is set by Brownian motion. In the gravitational field, this is generally held to become important, in liquid media, below 0.5  $\mu$ , but the practical limit is usually somewhat higher on account of the time taken in settling, and the difficulty of completely eliminating convection currents. By substituting a centrifugal field, however, many workers have succeeded in reducing the lower limit very considerably. In practice, wall effects, imposed by the necessity for confining the sedimentation fluid in a vessel of finite size, may be neglected. Much more important are the mutual interfering effects between the particles themselves. The accuracy of many methods is impaired because of the comparatively high concentrations which have to be used in order to follow the course of sedimentation experimentally. In such conditions there is a tendency for the finer particles to be underestimated, through their being carried down by the larger ones. The evidence as to what concentrations may be considered excessive is somewhat conflicting. Martin (p. 77)<sup>42</sup> has concluded from centrifugal sedimentation experiments with titanium dioxide (practically all below 1  $\mu$ .) that unhindered settling may be assumed up to concentrations as high as 3% by volume. In addition to the above considerations, it is obviously important that there should be no interaction (chemical, adsorption, or solution), between the solid and liquid phases. Space does not permit all the sedimentation methods to be described in detail. An attempt has been made, however, to give the most important references.

(i) *Pipette Methods*.—In the original pipette method of Andreasen,<sup>2</sup> a uniform suspension of the powder, about 1% by volume, is allowed to settle, and the weight less than a number of predetermined sizes is estimated by withdrawing small samples of definite volume from a fixed sampling point at the appropriate times. Evaporation of the medium enables the suspended matter to be weighed directly. The smaller particles take a considerable time to settle, which makes it desirable to take adequate steps to

limit convection.\* Schwyer<sup>36</sup> has described a modified pipette with which samples may be withdrawn at several levels, the time taken for a full-size determination thus being reduced.

The pipette method, in its conventional forms, may be criticised on account of the comparatively concentrated suspension needed to give samples large enough to be weighed accurately. Modifications to meet this difficulty by using more dilute suspensions have been proposed by several workers. The pipette method is probably the most popular of all methods of size analysis, and has been used for a very wide range of materials, including soils, clays, metallic oxides, cement, and limestone. The apparatus and technique possess the advantage of simplicity, although in routine work the accumulation of a large number of samples, all of which have to be dried, presents some difficulty.

(ii) *Centrifugal Sedimentation*.—As has been previously mentioned, the lower limit of particle size measurable by sedimentation may be greatly reduced by use of the centrifuge. To Svedberg is due a general equation, analogous to that of Stokes, applicable to particles settling in a centrifugal field (pp. 24, 73).<sup>45</sup>

Martin<sup>80</sup> describes the use of the method, as a cumulative one, for determining the size of titanium oxide down to a size of 0.2  $\mu$ . Norton and Spiel<sup>31</sup> have applied the method (Oicles down to 0.1  $\mu$ . Marshall<sup>31</sup> estimates in particle-size particles, placed upon the surface in the scientific literature sugar or urea solution, which the most a centrifugal field, and so arrives at a size analysis. Richardson<sup>88</sup> has proposed a method in which the course of centrifugal sedimentation is followed photographically. Because, in practice, the centrifuge takes a finite time in accelerating to constant speed and in coming to rest, the upper limit of size measurable by this technique is about 10  $\mu$ .

Several workers have described applications of both the supercentrifuge and the ultracentrifuge<sup>46</sup> in the study of the size distribution of particles in clays and pigments (p. 42).<sup>42</sup>

Centrifugal sedimentation is of great value for the preparation of closely-graded fractions for the testing and calibration of other methods of size determination.

(iii) *The Hydrometer Method*.—In the hydrometer method the sedimentation is studied by measuring the changes in density which occur at a known level from the surface of an originally homogeneous suspension. The method was first described by Bouyoucos<sup>6</sup> and has since been adopted as an A.S.T.M. Standard Method for the Mechanical Analysis of Soils (1941). A detailed description of the method is given by Klein (p. 52),<sup>42</sup> who has used it for the measurement of the size distribution of cements in kerosene or isopropyl alcohol. A concentration of about 11-3% by volume is recommended. Norton and Spiel<sup>31</sup> have, however, described its use down to a particle size of 0.1  $\mu$ . in the centrifugal analysis of clays.

The method is extremely simple and convenient, but is liable to the same criticisms which apply to others using relatively high particle concentrations; in addition, the introduction and withdrawal of the hydrometer must be

expected to cause some disturbance of the suspension. A further objection, which can only be met in part by attention to design, is that the hydrometer does not displace liquid at one level only. Deposition of particles upon the bulb must also cause some inaccuracy. Notwithstanding these theoretical disadvantages, however, it is claimed that the hydrometer gives results agreeing reasonably well with those obtained by other methods.

(iv) *Manometric Method.*—In the manometric method, first put forward by Wiegner,<sup>41</sup> particle-size distribution is arrived at by measurement of the variation of the pressure at a definite distance from the surface of a suspension. The chief practical difficulty is that the pressure variations in a reasonably dilute suspension are very small. Many magnifying devices have been proposed. In the apparatus of Knapp<sup>28</sup> used for cement analysis, the pressure record is obtained photographically. In a recent variation due to Jones and Barlow<sup>32</sup> the height of the manometer meniscus is adjusted, as sedimentation progresses, to a fixed value by means of a micrometer screw.

(v) *The Sedimentation Balance.*—Cumulative sedimentation data may be obtained directly by observing the weight of particles which settle on a balance pan hanging in a suspension. The method has attracted a great deal of attention in the United States. Among noteworthy applications may be mentioned those of Svedberg and Rinde<sup>38</sup> and Bishop,<sup>5</sup> who respectively used the method for mercury hydrosols and hydrated limes. The chief sources of error arise from the difficulty of entirely eliminating convection and from the changes in density which occur in the liquid beneath the balance pan.

(vi) *Pendulum Method.*—The pendulum method is an adaptation of that described by Manning and Taylor,<sup>28</sup> by whom it was used for a study of coal-oil suspensions. The suspension is contained in a tube mounted as a pendulum. Sedimentation is accompanied by changes in the period of the pendulum, from which the size distribution may be calculated.<sup>27</sup> Since the particle concentration used is high (at least 4%), the most valuable application of the method would seem to be for obtaining relative data for sludges, etc.

(vii) *Light-extinction Sedimentation Method.*—A distinction should be drawn between measurements of total turbidity, to give the average particle size of a dispersion, and the measurement of size distribution by the light-extinction method. The former will be dealt with separately later in this article. The application of turbidity measurements to the investigation of particle-size distribution was first described by Wagner<sup>40</sup> and Richardson.<sup>32</sup>

In the light-extinction method the concentration of particles in a settling suspension is determined by measuring, usually photoelectrically, the amount of light cut off by them, at a specified level, at a number of time intervals. A beam of light is passed through the suspension at right-angles to the direction of sedimentation. The thickness of the beam is small compared with the total sedimentation height. In order that the obscuration caused by the particles

should correspond as closely as possible with the projected area, the beam must be substantially parallel and of uniform intensity.

It is generally held that the absorption of light passing through a suspension of particles in a liquid follows the Lambert-Beer law (v. Vol. VII, 1766), which may be expressed as

$$I = I_0 e^{-kmcx}$$

where  $I_a$  and  $I$  are respectively the intensities of the beam at incidence and emergence,  $x$  the length of the light path,  $m$  the mass concentration, and  $A$  the extinction coefficient. Subject to the validity of certain assumptions, chiefly in regard to the extinction coefficient, to which reference will be made later, it follows that the ratio  $\log(I_0/I)$  is directly proportional to the concentration of particles.  $I_a$  represents the light actually transmitted by the pure suspending medium, since this will itself absorb light. If then the light transmitted by the originally homogeneous suspension is known, and Stokes' law is applied to calculate the diameters of the particles just large enough to fall below the light beam for a number of convenient time intervals, an *area-undersize* curve may be drawn directly. If it is assumed that the mass of the particles is proportional to the third power of their equivalent Stokes' diameters, then integration of the area enclosed between the area curve above and the appropriate axis enables a *mass-undersize* relation to be derived.

The more important assumptions made are as follows:

(a) No light scattered in a forward direction is measured, and the particles are large enough for diffraction effects to be neglected. For small particles the extinction is lower than that required by the above theory. For detailed treatment of the theory of light transmissions by suspensions of small particles the reader is referred to papers by Schweyer and Work (pp. 11-14)<sup>42</sup> and by Richardson.<sup>33</sup> Richardson states that scatter effects become serious when the value of  $2\pi d/\lambda$ , where  $d$  is the particle diameter and  $\lambda$  the wave-length of the light used, becomes less than 10. Strictly speaking, therefore, with light of  $\lambda = 0.5\mu$ , particles below about  $2.5\mu$  should be absent. Preliminary gravity or centrifugal separation provides a convenient means for the removal of the smallest particles. Schweyer and Work (p. 14)<sup>42</sup> quote experimental results, for materials of widely different size distributions indicating that when the particle concentration is increased so that the extinction is greater than about 70%, the proportional obscuration progressively diminishes. The explanation given for this fact is that the direct beam is augmented by scattered light passed on by multiple reflection. Since, however, such high concentrations are not normally used, no serious error from this cause need be expected.

(b) The optical constants of the particles, which are involved in the extinction coefficient, are independent of their size. Schweyer and Work (p. 17)<sup>42</sup> consider that only for cement and silica is this assumption supported by available experimental data. Earlier work by Traxler and Baum<sup>88</sup> had also suggested that, from this point of view, cement was more suit-



able for examination by the method than were some other powders. This is undoubtedly a field in which further research is needed.

(c) The shape factor, upon which the extinction coefficient also depends, does not vary with particle size. With diminishing size the particles of many substances may become more nearly spherical, but insufficient is known to enable the importance of this, and the fact that the particles are oriented during settling, to be assessed.

(d) There are no effects connected with the optical constants of the suspending medium. Errors could conceivably occur through the preferential absorption of certain wave-lengths by the medium. Since photo-cells are colour sensitive, it would be preferable, on these grounds, to use monochromatic light. The reason this is not generally done is probably that the difficulty of obtaining a sufficiently intense beam (and so a suitably large galvanometer deflection) is increased if white light is not used.

(e) The conditions, which apply to all sedimentation methods, of absence of convection and interference between particles, are fulfilled. The method compares well with others in that the concentration of particles used is very low, usually being not greater than 0.02% by volume, so that the ideal of free settling conditions is closely approached.

There are several variations in light-extinction apparatus which are worthy of notice. In order to reduce the time taken for an analysis down to 1 or 2 l, both Wagner's apparatus<sup>48</sup> and that of Richardson<sup>38</sup> have optical systems which can be raised and lowered. In Heywood's apparatus,<sup>20</sup> on the other hand, the analysis is speeded up by carrying out eight determinations together. The optical system, pivoted at one end, can be rotated so that the light beam passes through any one of nine similar cells. The ninth cell, which contains the clear dispersing liquid, serves as a blank for the whole batch of samples. This procedure has the advantage that the intensity of the incident light is measured throughout a test using only one photo-cell. No error, therefore, is caused by any change which may occur in the response of the cell.

Another method of shortening the time taken by the analysis is described by Richardson.<sup>38</sup> The suspension, after being allowed to settle for a known period, is photographed and the record examined photometrically. This technique may also be applied to suspensions settling in a centrifugal field.\*

In Wagner's turbidimeter, the thickness of the beam ( $\pm 3$  cm.) seems unnecessarily large. Other workers<sup>20, 33</sup> have found it possible to reduce this dimension considerably.

The largest size of particle which can be measured by the method depends upon the differential density, height of fall, and viscosity of the medium. In practice, if small particles are present, the scope for adjustment of density and viscosity is rather limited, owing to the uncertainty which exists in regard to the agglomerating effect of the medium. If an accurate measure of the size of the largest particles is required, the best course is probably to separate these by preliminary sedimentation, and then make light-extinction measurements in

a viscous medium. It is, however, quite feasible to measure the size distribution of silica, for example, from 50  $\mu$ . downwards in one operation in water.

The uncertainties which attend the light-extinction method have been commented on above. When comparison is made with other sedimentation methods, it is probable that these are more than compensated for by the very low particle concentration which it is possible to use.

The method has attracted great interest during recent years, and has been adopted in America as a standard for the testing of cement.<sup>43</sup> Most of the available comparison figures with other methods refer to cement. Lea<sup>26</sup> reports good agreement with Andreasen and air-elutriation methods down to a size of 7.5  $\mu$ ., and Roller and Roundy (p. 44)<sup>4a</sup> with the air-elutriator between 60/x. and 7.5  $\mu$ .. Klein (p. 63)<sup>42</sup> has found a measure of agreement between turbidimeter and hydrometer. For zircon, however, it is reported (p. 21)<sup>44</sup> that the light-extinction method yields the analysis of a finer powder than does the pipette method. As the faults in the light-extinction method should lead to under-estimation of fineness, there can be, presumably, a still greater error in the same direction in the Andreasen method, due to the higher concentration used.

(viii) *Analysis by Elutriation.*—In elutriation analysis, Stokes' law is applied to calculate the limiting velocities required to float off particles of a definite size. Both air- and water-elutriators have been widely used.

In the particle-size air-analyser of Roller<sup>85</sup> a regulated stream of air is passed through the powder, which is contained in an oscillating glass U-tube. The stream passes upwards through a wide settling chamber, and the undersize particles are trapped in a "paper thimble". A considerable time is required for the complete splitting-up of the aggregates, and a method for computing the "end-point" is described by Roller and Roundy (p. 38).<sup>42</sup>

The "infrasizer" of Faultain<sup>17</sup> comprises six conical separating chambers joined in series, so that a corresponding number of sized fractions are obtained. The diameters of the tops of successive separators are in  $\sqrt{2}$  ratio. The battery of separators is shaken continually, in order to keep the sides free from accumulated dust. The "infrasizer" has been used for analyses down to 5  $\mu$ . It is stated to give highly concordant results, with exceedingly sharp "cuts."

Air-elutriation provides a suitable method for size analysis when knowledge of particle or "agglomerate particle" size in air-dispersion is desired. It possesses the disadvantage that comparatively large quantities of powder are required. Several workers have found a considerable divergence between the calculated and actual limits of the size ranges of fractions obtained. This has been ascribed to the shape factor, to incomplete dispersion, and to lack of uniformity in air velocity over the cross-section of the separators.

The most useful application of water-elutriators would appear to be in the size analysis of heavy mineral ores, since a large differential density is



advantageous. The elutriators are usually of the series type; most commonly<sup>2, 4</sup> three vessels are employed.

*The Measurement of Specific Surface, or Average Particle Size.*—The methods described in the foregoing give information as to the distribution of sizes of the particles in a powder. By assuming a shape constant, the size-distribution data may be used to calculate the specific surface.<sup>18</sup> The values so obtained must be regarded as more or less arbitrary, since a large proportion of the surface of a powder may be associated with the particles smaller than the lowest size actually measured. There exist, however, several methods whereby specific surface may be measured directly.

(c) Adsorption Methods.—During recent years Emmett and his collaborators<sup>10</sup> have developed a low-temperature gas adsorption method for measuring the surface areas of metallic catalysts, and have successfully extended its application to the examination of pigments, carbon blacks, cement and other finely divided solids. The gases most extensively used have been nitrogen and helium, on account of their inertness. In essence the method consists in determining the number of molecules of gas required to give a unimolecular layer. Knowledge of the cross-sectional area of the gas molecule enables the surface of the adsorbent to be calculated. The adsorption isotherms obtained experimentally are of an S-shaped form, with a long linear middle portion, the lower extremity of which was chosen by Emmett, originally on empirical grounds, as the point corresponding with the completion of the monolayer. The adsorption is carried out at about 78°K., using liquid nitrogen in the surrounding bath. Excellent agreement with the electron microscope for the mean diameter of carbon-black particles was found, and with permeability measurement and ultra-microscopical examination for zinc oxide. The method would seem to be an exceedingly valuable one for the evaluation of those materials which are too fine for the application of the customary size-analysis methods. It is, of course, only applicable to non-porous materials.

Adsorption from solution as a method of determining average particle size has been suggested by many workers, amongst whom may be mentioned Ewing (p. 107)<sup>42</sup> and Imre.<sup>21</sup>

(d) Permeability Measurement.—Permeability methods of determining specific surface are based on the Kozeny equation for the flow of a fluid through a rigid bed of particles. The equation may, for this purpose, be written in the form

$$S = \sqrt{\frac{AP}{k(1-\epsilon) \eta VpL}}$$

where  $S$  is the specific surface (sq. cm. per g.),  $\Delta P$  the fall in pressure across the bed in dynes per sq. cm.,  $A$  the cross-sectional area of the bed in sq. cm.,  $\epsilon$  the fractional voidage of the bed,  $k$  the Kozeny constant (50),  $\eta$  the viscosity of the liquid in poises,  $V$  the rate of flow in cc. per sec., and  $L$  the thickness of the bed in cm.

The development of the method is due primarily to Casassa<sup>8</sup>, who has studied the flow of liquids at constant pressure through beds

of a number of different materials of varying size ranges. For zinc powder and for silica the validity of the method was firmly established (to an accuracy of  $\pm 5\%$ ) for particles down to 2  $\mu$ . It is important that the liquid should be capable of completely wetting the particles, otherwise serious under-estimation of specific surface would ensue. Comparing the results with those of air-permeability measurements, Carman (p. 27)<sup>42</sup> concluded that, for particles below 50  $\mu$  the air method, owing to the effects of incomplete dispersion, underestimates fineness. Gooden and Smith<sup>16</sup> report results in the same sense. On the other hand, Lea and Nurse<sup>26</sup> put forward the view that the air-permeability results are more accurate, suggesting that, in the presence of liquid, the porosity of the bed is reduced by adsorbed films. These authors find support for their contention in the fact that, for cements, the surface mean diameter calculated from sedimentation data agrees more closely with air-permeability measurements. As has been pointed out above, however, calculated specific surface values should be accepted with some reserve.

Despite the uncertainties referred to, the permeability method is undoubtedly one of the most convenient for the measurement of average particle size for routine purposes. This applies especially to the recent modification of the air-permeability method put forward by Rigden,<sup>84</sup> which avoids the necessity for maintaining an accurately measured and constant rate of flow.

(c) Turbidimetric Method.—For particles which are small compared with the wave-length of light, the size may be evaluated by application of Rayleigh's law, from which may be deduced the relation that the logarithm of the ratio of the transmitted light to the incident light varies directly as the cube of the diameter and inversely as the fourth power of Mie radiation.

For systems in which the particles are distributed over a wide range of sizes, the principles which govern the transmission of light are the same as those which have been discussed in the description of the light-extinction size analysis method. The use of extinction measurements for the calculation of specific surface is, therefore, only strictly valid when particles smaller than about 2  $\mu$  are absent. When this is realised, however, the measurements can still be, of great value when used in a relative manner.

For spherical particles or particles in a state of random orientation, as in a stirred suspension, the ratio of total surface to projected area is equal to 4, so that, applying the Lambert-Beer law the specific surface is given by the formula

$$S = \frac{4}{lc} \log_e \left\{ \frac{I_a}{I} \right\}$$

where  $I_a$  is the intensity of the incident light,  $I$  that of the transmitted light,  $l$  the length of the light path, and  $c$  the concentration of particles. This type of measurement is simple and may be made rapidly, and possesses the great advantage that it can be used when only small quantities of material are available.

Conclusion.—The existence of such a great variety of methods for particle-size measurement arises from the necessity for treating each size-analysis problem on its merits. The reasons

for this have been briefly indicated in the introduction to this article. It will be evident that most of the methods involve a dispersion problem. For many purposes it is desirable to test the particles in conditions where dispersion is as complete as possible. Most work on dispersion has been on empirical lines, but a paper by Andreasen<sup>1</sup> contains much useful information, including a description of tests of dispersion relating to some powders for which size analysis is commonly required.

REFERENCES.

- 1 A. H. M. Andreasen, Ingeniarvidenskabelige Skriffter, Copenhagen, 1939,3,11.
- 2 A. H. M. Andreasen, Kolloid-Beih. 1928,27, 349.
- 3 H. B. Barnes and C. J. Burton, Bull. Amer. Soc. Test. Mat. 1942, No. 116, 34.
- 4 L. Andrews, Proc. Inst. Eng. Inspection, 1927, 23, 25.
- 5 D. L. Bishop, J. Res. Nat. Bur. Stand. 1934,12,173.
- 6 G. L. Bouyoucos, Soil Sci. 1937,23, 343.
- 7 W. F. Carey and C. J. Stairinand, Trans. Inst. Chem. Eng. 1938,16, 67.
- 8 P. C. Carman, J.S.C.I.1938,57, 226.
- 9 P. C. Carman, *ibid.* 1939, 58, 1.
- 10 P. H. Emmett and P. De Witt, Ind. Eng. Chem. [Anal.], 1941,13, 28.
- 11 G. L. Fairs, Chem. and Ind. 1943,62, 374.
- 12 D. C. Gamble and C. E. Barnett, Ind. Eng. Chem. [Anal.], 1937,9,310.
- 13 S. D. Gehman and T. C. Morris, *ibid.* 1932, 3, 300.
- 14 H. Green and E. F. FuUam, J. Appl. Phys. 1943, 14, 382.
- 15 H. L. Green, Trans. Inst. Min. Met. 1936,44, 89.
- 16 E. L. Gooden and C. M. Smith, Ind. Eng. Chem. [Anal.], 1940,12, 479.
- 17 H. E. T. Haultain, Trans. Canad. Inst. Mining Met. 1937,40, 229.
- 18 H. Heywood, Proc. Inst. Mech. Eng. 1933,125, 359.
- 19 H. Heywood, *ibid.* 1938,140, 267.
- 20 H. Heywood, B.P. 562398,1943.
- 21 I. Imre, Kolloid-Z. 1942, 99, 147.
- 22 F. R. Jones and C. G. Barlow, J.S.C.I. 1943, 62, 125.
- 23 B. T. Knapp, Ind. Eng. Chem. [Anal.], 1934, 6, 86.
- 24 J. Kozeny, Ber. Wien. Akad. 1927,136a, 271.
- 25 F. M. Lea, J.S.C.I. 1939, 58, 146.
- 26 F. M. Lea and H. W. Nurse, *ibid.* 1943,68; 277.
- 27 J. H. McMillen, L. F. Stutzman, and J. fc. Hedrick, Ind. Eng. Chem. [Anal.], 1941,13, 475.
- 28 A. B. Manning and B. A. Taylor, Trans. Inst. Chem. Eng. 1936,14, 46.
- 29 C. E. Marohall, J.S.C.I.1931,50, 444.
- 30 S. W. Martin, Ind. Eng. Chem. [Anal.], 1939,11, 471.
- 31 F. S. Norton and S. Spiel, J. Amer. Ceram. Soc. 1938,21, 89.
- 32 E. G. Richardson, J. Agric. Sri. 1934,24, 459.
- 33 E. G. Richardson, Proc. Physical Soc. 1943,55,48.
- 34 P. J. Rigden, J.S.C.I.1943,62,1.
- 35 S. S. Roller, Proc. Amer. Soc. Test. Mat. 1932, 32, 607.
- 36 H. Schweyer, Ind. Eng. Chem. [Anal.], 1942,14, 621.
- 37 M. N. States, Proc. Amer. Soc. Test. Mat. 1939, 39, 796.
- 38 T. Svedberg and H. Rinde, J. Amer. Chem. Soc. 1923, 45, 493.
- 39 R. N. Traxler and L. A. H. Baum, Proc. Amer. Soc. Test. Mat. 1935,35, 457.
- 40 L. A. Wagner, *ibid.* 1933, 33, 633.
- 41 G. A. Wiegner, Landw. Versuchs-Stat. 1918, 91, 41.
- 42 \*\* Symposium on New Methods for Particle Size Determination in the Sub-sieve Range," Amer. Soc. Test. Mat. 1941.
- 43 \*\* Tentative Method C115," see ref. 42
- 44 " Report on Discussions on Determination of Particle Size in Sub-sieve Range," British Colliery Owners' Research Association and British Coal Utilisation Research Association, 1944.
- 45 J. M. DaUavaUe, " Micromeritics." Pitman, 1943.
- 46 Ann. N.Y. Acad. Sci. 1942,43,175.

D. G. S.

**PARTITION FUNCTION.** The partition function is a phrase coined by the late Sir Ralph Fowler to convey in our language what Max Planck meant by the composite German noun *die Zustandssumme*. As its name implies, the partition function is a dimensionless quantity. It summarises in convenient mathematical form the way in which the energy (and other properties) of a colony of molecules is distributed or *partitioned* among the molecular inhabitants. It is a function of the molecular weight, the temperature, the molecular volume, the inter-nuclear distances, the molecular motions, and the intermolecular forces. When its relation to all these is established, the whole story of the molecule in question is known. To explain how the notion of the partition function has caught on so generally or been so extensively employed would be to write an account of the growth of modern statistical mechanics. In brief, the explanation is that the partition function provides the most convenient bridge yet devised to link the microscopic properties of individual molecules (such as their discrete energy levels, moments of inertia, and dipole moments) with the macroscopic properties (such as molar heat, entropy, and polarisation) of a system containing a large number of molecules.

**Definition.**—In any system of molecules at equilibrium, the number of molecules possessing an energy *e* each is proportional to the Boltzmann factor,  $e^{-e/kT}$ , where *e* is the base of the natural logarithms, *c* is the energy of one molecule, *k* is the Boltzmann constant (1.372x 10<sup>-16</sup> erg per degree), and *T* is the absolute temperature. In such a system, there will be a certain number (say *N*<sub>1</sub>) of molecules possessing energy *e*<sub>1</sub> each; another number (say *N*<sub>2</sub>) possessing energy *e*<sub>2</sub> each; and so on. The total number, *N*, of molecules in the system is

$$N = N_1 + N_2 + N_3 + \dots = \sum N_i \quad (1)$$

and the total energy of the system is

$$E = N_1 e_1 + N_2 e_2 + N_3 e_3 + \dots = \sum N_i e_i \quad (2)$$

The *partition function*, which is usually denoted by *f*, is simply the sum of these Boltzmann factors, i.e.,

$$f = e^{-e_1/kT} + e^{-e_2/kT} + e^{-e_3/kT} + \dots \quad (3)$$

As the molecular energy increases, the Boltzmann factor decreases. Energy among molecules is not unlike money among men: the poor are numerous, the rich few. The series represented by equation (1) thus rapidly converges, and, although in principle we should always sum to infinity, in practice it is sometimes sufficient to count only the first ten terms or so. For generality, equation (3) is therefore summarised as follows:

$$f = \sum_{i=0}^{\infty} e^{-e_i/kT} \quad (4)$$

where *e*<sub>*i*</sub> is the energy possessed by a molecule in the *i*'th state.

The Boltzmann law, to which reference has already been made, may be expressed mathematically as follows:

$$N_i = N e^{-e_i/kT} \quad (5)$$

where  $K$  is a constant for the system considered. Similarly, for the numbers of molecules occupying groups in the higher energy-levels, we have

$$N_2 = K e^{-\epsilon_2/kT}$$

$$N_3 = K e^{-\epsilon_3/kT}$$

and so on. Adding, and using equation (3), we see that

$$N = Kf \tag{6}$$

in which  $N$  is the total number of molecules in the system. Eliminating  $K$  from equations (5) and (6), we see that  $N/N_i = e^{\epsilon_i/kT} / f$ , or, generally, that

$$N/N_i = e^{\epsilon_i/kT} / f \tag{7}$$

From this equation we note that the partition function,  $f$ , bears the same relation to the total number of molecules,  $N$ , as the Boltzmann factor bears to the number,  $N_i$ , of molecules in the specified energy level,  $\epsilon_i$ . The partition function may thus be regarded as a *generalised Boltzmann factor*.

The partition function defined by equation (4) may be more precisely termed the *molecular partition function*. The *grand partition function*,  $F$ , is related to it as follows:

$$F = \sum_i e^{-\epsilon_i/kT} \tag{8}$$

The Relation of the Partition Function to Certain Thermodynamic Functions.— Equation (3) may be differentiated with respect to temperature at constant volume. This gives:

$$\left(\frac{df}{dT}\right)_v = \left(\frac{\epsilon_1}{kT^2}\right) e^{-\epsilon_1/kT} + \left(\frac{\epsilon_2}{kT^2}\right) e^{-\epsilon_2/kT} + \dots$$

$$= \left(\frac{1}{kT^2}\right) \sum_0^{\infty} \epsilon_i e^{-\epsilon_i/kT} \tag{9}$$

On multiplying throughout by  $kT^2$  dividing throughout by  $f$ , and noting that  $dx/x$  equals  $d(\ln x)$ , the following expression is obtained:

$$kT^2 \left(\frac{d(\ln f)}{dT}\right)_v = \left(\frac{\epsilon_1}{kT}\right) \frac{e^{-\epsilon_1/kT}}{f} + \left(\frac{\epsilon_2}{kT}\right) \frac{e^{-\epsilon_2/kT}}{f} + \dots$$

$$= \left(\frac{1}{f}\right) \sum_0^{\infty} \epsilon_i e^{-\epsilon_i/kT} \tag{10}$$

It is possible to substitute for the various ratios in this equation the number ratios to which, according to equation (7), they are equal. It is then found that:

$$kT^2 \left(\frac{d(\ln f)}{dT}\right)_v = N_1 \frac{\epsilon_1}{kT} + N_2 \frac{\epsilon_2}{kT} + N_3 \frac{\epsilon_3}{kT} + \dots$$

$$= \sum_0^{\infty} N_i \frac{\epsilon_i}{kT} \tag{11}$$

Nearly, the sum of the various products (number of molecules in a given energy group)  $\times$  (energy of each molecule in that group) represents the total energy,  $E$ , of the whole system of  $N$  molecules. Hence, combination of equations (2) and (11) gives:

$$E = NkT^2 \left(\frac{d(\ln f)}{dT}\right)_v \tag{12}$$

The general relation between the total energy,  $E$ , of a system of  $N$  similar molecules at constant temperature,  $T$ , and the molecular partition function,  $f$ ,

When a system is at equilibrium, the mathematical probability,  $1/f$ , of its existence has a maximum value; and its entropy,  $S$ , has also a maximum value. That there is a relation between the two is obvious, but it was Boltzmann who first concluded that  $S$  is solely a function of  $W$  and that the relation must be a logarithmic one. By virtue of the Third Law of Thermodynamics, which has been established during this century, Boltzmann's relation may now be expressed in the simple form:

$$S = k \ln W \tag{13}$$

The mathematical probability of a system is defined as the number of distinguishable ways in which that system can be realised.  $N$  molecules may be arranged in  $N!$  ways, but not all these arrangements are distinguishable. If  $N_1$  molecules have all the same energy,  $\epsilon_1$ , arrangements within this group lead to indistinguishable configurations. Similarly, interchange among the  $N_2$  molecules in the group having energy  $\epsilon_2$  per molecule leads to no new distinguishable arrangements. The total number,  $N!$ , of conceivable arrangements must thus be reduced by the product  $N_1! N_2! N_3! \dots$ , since each of these numbers represents the number of ways in which molecules in a given energy group can be arranged. Thus:

$$W = \frac{N!}{N_1! N_2! N_3! \dots} = N! (N_i/N!)^{-1} \tag{14}$$

By combining equations (13) and (14), and making use of Stirling's approximation,

$$\ln x! = x \ln x - x, \tag{15}$$

which is valid when  $x$  is large, equation (13) may be cast into the following form:

$$\frac{S}{k} = \ln W = N \ln N - N$$

$$- \left\{ \begin{matrix} N_1 \ln N_1 - N_1 \\ N_2 \ln N_2 - N_2 \\ N_3 \ln N_3 - N_3 \\ \dots \end{matrix} \right\} \tag{16}$$

According to equation (1), however, the numbers in the last column cancel out, leaving

$$\frac{S}{k} = N \ln N - \sum_i N_i \ln N_i \tag{17}$$

By writing equation (7) in logarithmic form, it is seen that:

$$\ln N_i = \ln f - (\epsilon_i/kT) - \ln N \tag{18}$$

and consequently that:

$$N_i \ln N_i = N_i \ln N - (N_i \epsilon_i/kT) - N_i \ln f$$

The sum of all such terms is

$$\sum_i N_i \ln N_i = N \ln N - \left( \frac{N_1 \epsilon_1}{kT} \right) - N_1 \ln f$$

$$+ N_2 \ln N - \left( \frac{N_2 \epsilon_2}{kT} \right) - N_2 \ln f$$

$$+ N_3 \ln N - \left( \frac{N_3 \epsilon_3}{kT} \right) - N_3 \ln f$$

$$+ \dots + \dots + \dots$$

$$= N \ln N - \sum_i (N_i \epsilon_i/kT) - N \ln f \tag{18}$$

By means of equation (2), therefore,

$$(S/k) = (E/kT) + N \ln f \tag{19}$$

By substituting for  $E$  the expression already derived (equation (12)), the general relation between the entropy,  $S$ , and the partition function,  $f$ , is arrived at:

$$S = Nk \left[ \ln f + T \left(\frac{d(\ln f)}{dT}\right)_v \right] \tag{20}$$

Helmholtz defined the free energy, or maximum work term,  $A$ , as follows:

$$A = E - TS \quad \dots \quad (21)$$

On inserting the general expressions derived above for  $E$  and  $S$ , this becomes:

$$A = -NkT \ln f \quad \dots \quad (22)$$

Equations (12), (20), and (22) may be regarded as key equations, from which the relationships between/ and most of the other thermodynamic functions may readily be derived. The pressure,  $P$ , for example, is defined thermodynamically as follows:

$$P = -(dA/dV)_T \quad \dots \quad (23)$$

In terms of the partition function, therefore, it is clear from equation (22) that the pressure is expressible as follows:

$$P = NkT \{d(\ln f)/dV\}_T \quad \dots \quad (24)$$

Similarly, the thermodynamic definitions of the isothermal compressibility,  $\beta$ , and of the specific heat,  $C_v$ , at constant volume, which are, respectively,

$$\beta = -(1/P)(dP/dP)_T \quad \dots \quad (25)$$

$$\text{and} \quad C_v = (dE/dT)_v \quad \dots \quad (26)$$

readily lead to the following relationships, based on equations (12) and (24):

$$1/\beta = -NkT^2 \{d(\ln f)/dT\}_T \quad \dots \quad (27)$$

$$C_v = Nk \{T^2 d^2(\ln f)/dT^2\}_T + 2T \{d(\ln f)/dT\}_T \quad (28)$$

Every thermodynamic equation may likewise be related to the partition function.

**Examples of Simple Partition Functions.**—From equation (3) it is obvious that the partition function can always be evaluated numerically when the discrete energy levels of the molecules are known. These levels may be found either experimentally, by analysing the absorption or emission of radiation in the various spectral regions, or theoretically, by solving the Schrödinger equation for the appropriate molecule motions. The former method is the only one at present available in the study of complex molecules. The latter method is applicable to simple molecules, or to simple motions executed by complicated molecules, and certain examples afforded by it may now be discussed

(a) *Free Linear Motion.*—For the linear motion of a point particle, of mass  $m$ , moving freely along a length  $l$ , the discrete energy levels allowed by quantum laws are:

$$\epsilon_w = \frac{h^2 w^2}{8ml^2}; \quad w = 1, 2, 3, \dots \quad (29)$$

According to equation (3), the partition function is accordingly

$$f = \sum_{w=0}^{\infty} e^{-\frac{h^2 w^2}{8ml^2 kT}} \quad \dots \quad (30)$$

With sufficient accuracy for most purposes, the summation yields the following result:

$$f = (2\pi m kT / h^2) l \quad \dots \quad (31)$$

When an atom, or a coherent group of atoms, is being torn from the remainder of a complex molecule, its relative motion when it is about to

break away resembles linear translation in a force-free field. Equation (31) is therefore of interest in chemical kinetics.

(6) *Free Superficial Motion.*—The same considerations, applied to the motion of a point particle free to move simultaneously along a length  $l_1$  in one direction and a length  $l_2$  in another direction at right-angles to it, lead to the partition function:

$$f = (2\pi m kT / h^2) l_1 l_2 \quad \dots \quad (32)$$

But  $l_1 l_2$  which may be denoted by  $\theta$ , represents the area accessible to the molecule, so that

$$f = (2\pi m kT / h^2) \theta \quad \dots \quad (33)$$

This equation is the general jumping-off ground by statistical theory for the treatment of surface phenomena, such as interfacial tension and superficial adsorption.

(c) *Free Motion in a Confined Space.*—Suppose the particle were capable of performing free superficial translation on a plane area,  $O_1$ , and simultaneously of executing free linear motion of extension  $l_2$ , in a direction at right-angles to the plan  $J$ . We should then find for the partition function the product

$$\dots \quad (34)$$

Now  $O_1 l_2$  is the volume,  $v$ , accessible to the molecule; hence

$$f = (2\pi m kT / h^2) v \quad \dots \quad (35)$$

which is the partition function for a point particle, of mass  $m$ , free to move in (but confined to) a cell of volume  $v$  at temperature,  $T$ .

(d) *Free Motion in a Shared Space.*—Let us consider a number,  $N$ , of chemically identical molecules, each of which is capable of free translatory motion within a cell of average volume,  $v$ . By equation (8), the grand partition function is  $\{(2\pi m kT / h^2) v\}^N$ . Suppose the molecules, instead of being confined to the  $N$  different cells, were interchangeable, each interchange leading to a new molecular configuration which is indistinguishable from the original one. The grand partition function for the new system would be  $\{(2\pi m kT / h^2) v\}^N / N!$ , since  $N!$  is the number of arrangements of  $N$  particles. The system thus envisaged corresponds to that well-known and very helpful conception of the chemist known as the ideal gas, in which a total volume  $V$  is shared by  $N$  molecules, each occupying on an average a volume  $v$  ( $= V/N$ ). Use of equations (8) and (15), leads to the following partition function for an ideal-gas molecule of mass  $m$ , at temperature  $T$ :

$$f = (2\pi m kT / h^2) v \quad \dots \quad (36)$$

(e) *Harmonic Motion.*—According to the quantum theory, the energy of a linear oscillator executing simple harmonic vibration of frequency  $\nu$  is

$$\epsilon_c = (8+l)hv; \quad c = 0, 1, 2, \dots \quad (37)$$

The partition function is therefore

$$f = \sum_{c=0}^{\infty} e^{-\frac{(8+l)hv}{kT}} = e^{-\frac{8lv}{kT}} \{1 + e^{-\frac{hv}{kT}} + e^{-\frac{2hv}{kT}} + \dots\}$$

But since  $l+x+x^2+x^3 \dots = \frac{1}{1-x}$  it follows that

$$f = \frac{1}{1 - e^{-h\nu/2kT}} \left( 1 - e^{-h\nu/kT} \right)^{-1} \dots (38)$$

When the vibratory motion of a molecule about a mean position of equilibrium may be resolved into three vibratory motions, each of which is a simple harmonic one, the partition function becomes

$$f = \frac{1}{1 - e^{-h(\nu_1 + \nu_2 + \nu_3)/kT}} \left( 1 - e^{-h\nu_1/kT} \right)^{-1} \left( 1 - e^{-h\nu_2/kT} \right)^{-1} \left( 1 - e^{-h\nu_3/kT} \right)^{-1} \dots (39)$$

when the frequencies are different, and

$$f = \frac{1}{1 - e^{-3h\nu/2kT}} \left( 1 - e^{-h\nu/kT} \right)^{-3} \dots (40)$$

when the frequencies are identical. Details being omitted, this is the partition function which corresponds to Einstein's familiar treatment of the specific heat of monatomic solids, such as diamond.

\* (1) Free Rotation.—The energy levels allowed by the quantum theory for the free rotation of a rigid particle of moment of inertia  $I$  are

$$E = \frac{1}{2} J(J+1) \frac{h^2}{8\pi^2 I}; J=1, 2, 3, \dots (41)$$

This rotational energy, however, can be realised in  $(2J+1)$  ways, each corresponding to a separate solution of the Schrödinger equation. The partition function is accordingly:

$$f = \sum_{J=0}^{\infty} (2J+1) e^{-\frac{1}{2} J(J+1) \frac{h^2}{8\pi^2 I kT}} \dots (42)$$

The summation is readily evaluated when  $\frac{1}{2} J(J+1) \frac{h^2}{8\pi^2 I kT}$  is much less than  $kT$  which holds for massive molecules generally, but for light molecules duly at high temperatures. The result is

$$y = \left( \frac{8\pi^2 I kT}{h^2} \right)^{1/2} \dots (43)$$

If the rotator is symmetrical, this partition function must be reduced by an integer,  $\sigma$ , which is equal to the number of indistinguishable permutations obtained by the rotation of the molecule. Hence

$$f = \frac{1}{\sigma} \left( \frac{8\pi^2 I kT}{h^2} \right)^{1/2} \dots (44)$$

Elementary Applications of the Partition Functions.—In conclusion, a few examples may be given to show how these considerations enable us to derive theoretical expressions for macroscopic properties, such as free energy, entropy, internal energy, and specific heat of simple molecular systems in terms of microscopic properties of the molecules comprising them, such as the moment of inertia, the molecular weight, and vibration frequency.

Combining equations (22) and (43), the rotational free energy of a system of  $N$  rotators of moment of inertia  $I$  becomes

$$A = -NkT \ln \left( \frac{8\pi^2 I kT}{h^2} \right) \dots (45)$$

That equation (20) and (45) and

$$v = kT/p \dots (46)$$

the translational entropy of an ideal gas, of molecular weight  $m$ , at a pressure  $p$  is

$$S = Nk \left[ 4.757 + \ln \left\{ \frac{2\pi m kT}{h^2} \right\} \right] \dots (47)$$

If  $P$ , denotes the pressure in atmospheres, and  $M$  the molar weight (oxygen=16), this equation, after inserting numerical values for the constants, yields the following expression for the molar translational entropy:

$$S = fH \ln Jf + |f| \ln |r - \ln P - 2.300 \dots (48)$$

The internal energy of a system of  $N$  three-dimensional harmonic oscillators becomes, according to equations (12) and (40):

$$E = \frac{3}{2} N h \nu \coth \left( \frac{h\nu}{2kT} \right) \dots (49)$$

By means of equation (28), the corresponding expression for the specific heat at constant volume is:

$$C_v = 3Nk \left\{ \frac{h\nu}{2kT} \operatorname{cosech} \left( \frac{h\nu}{2kT} \right) \right\}^2 \dots (50)$$

References.

(i) Elementary.  
W. F. Giauque, J. Amer. Chem. Soc. 1930, 52, 4808.  
A. B. Ubbelohde, "An Introduction to Modern Thermodynamical Principles" Oxford, 1937.

(ii) Intermediate.  
K. F. Herzfeld, "Kinetische Theorie der Wärme," Müller-Poulet's Handbuch der Physik, Braunschweig, 1925.  
E. A. Moelwyn-Hughes, "Physical Chemistry," Cambridge, 1940.

(iii) Advanced.  
R. H. Fowler, "Statistical Mechanics," 2nd ed., Cambridge, 1936.  
B. Schrödinger, "Statistical Thermodynamics," Cambridge, 1940.

E. A. M.-H.  
PASSIVITY.—Origin of the Word.—The term *passivity* arose out of a correspondence which passed between Schönbein<sup>1</sup> and Faraday<sup>2</sup> in 1836. Schönbein described how, when iron which had been oxidised by heating in air was introduced after cooling into nitric acid of  $p$  1-35, it remained unaffected; a specimen of unheated iron was violently attacked if introduced without special precaution into acid of this concentration, but, if it was kept in contact with oxidised iron at the moment of its introduction, no attack took place, even after the two had been separated. If the unheated iron was then taken out and introduced into the acid in contact with a third specimen of iron (also unheated), this latter suffered no attack. Evidently it is possible to bring iron to a peculiar state in which the behaviour of ordinary iron disappears, and this state can be transmitted from one specimen to another. Schönbein referred to iron in this inert condition as *passive*, and iron in the ordinary, readily roasting condition as *active*.

One characteristic of passivity phenomena is the manner in which the behaviour of a metal depends on its previous history. In general, iron is violently attacked by dilute nitric acid (about  $p$  1-2); when it is introduced into the concentrated acid ( $p$  1-4), there is a slow reaction at first, after which the metal becomes passive; after "passivation" in concentrated acid, iron remains unattacked when introduced into acid of intermediate concentration (about  $p$  1-3), such as would quickly consume ordinary untreated iron; it can even withstand acid of  $p$  1-2 for a limited time before attack sets in. The actual

limits of concentration needed to determine activity or passivity vary with different samples of iron, but the same general principles seem to hold in all cases.

**Electrochemical Researches on Iron.**—It was apparent from the first that electrochemical factors are important in deciding between passivity and activity. Schönbein rendered unheated iron passive by anodic treatment in nitric acid, using a "couronne des tasses" as the source of e.m.f. Faraday made iron immersed in nitric acid alternately active and passive by alternate contact with zinc and platinum—which was equivalent to alternate cathodic and anodic treatment. The fact that in Schönbein's experiments active iron placed in nitric acid sometimes became passive through contact with iron previously rendered passive (or with iron oxidised by heating) was due to the current passing between the two, the originally active specimen being the anode.

Later experimenters studied passivity by applying an external e.m.f. to a cell consisting of iron electrodes immersed in a solution of a salt or acid—not necessarily nitric acid. In general, the iron anode of such a cell will, at the outset, suffer attack at high current efficiency, but if the current density is sufficient, anodic attack will practically cease after a certain time, and subsequently almost the whole current flowing will be devoted to the evolution of oxygen (a slow dissolution of the iron will still continue, representing perhaps 1% of the current). This change is accompanied by a shift of the anodic potential in the noble direction, so that after passivation a given e.m.f. will force a smaller current through the cell than before it. In the experiments of Schoch and Randolph,<sup>8</sup> the anodic potential (converted to the normal hydrogen scale) was usually between  $-0.4$  and  $-0.1$  v. (according to the solution and current density) so long as the anode was active, but rose to high positive values ( $+1.4$  to  $+1.9$  v.) when passivity set in.

If, after an iron anode has become passive, the current is turned off, the potential usually remains at a positive (passive) value for an appreciable time and then tumbles somewhat suddenly to a negative value characteristic of active iron. This tumble occurs much more quickly in acid solution than in neutral solution, and more quickly in sulphuric acid than in nitric acid (an oxidising agent). If, before the tumble takes place, the current is turned on again, the iron behaves as a passive anode, the current being devoted mainly to the production of oxygen; if the current is turned on after the tumble it is devoted mainly to the dissolution of iron.

**Analogous Phenomena in Non-ferrous Metals.**—Many metals, other than iron, when subjected to anodic treatment at high current densities, show a somewhat abrupt change to a state characterised by an abnormally high, "noble" potential, and by anodic products different from those normally met with at low current densities. But if the metal is one which forms a higher oxide soluble in the liquid used in the cell, dissolution does not necessarily cease when the potential rises to the "noble" level. For instance, a chromium anode at low

current density will pass into solution at a negative potential as a blue chromous salt. After a time, however, the production of chromous salt ceases, but if the e.m.f. is sufficient, the anode will dissolve as yellow chromic acid. The formation of this energy-rich, highly oxidised substance requires a high potential (at least  $+1.1$  v.); if the solution contains an iodide, such values cannot be reached, since iodine can be liberated at about  $+0.6$  v. and the potential therefore fails to reach the value needed for dissolution in the hexavalent state; this explanation of the action of iodides—previously misunderstood—was provided by Bennett and Burnham.<sup>4</sup> Other examples of metals which yield divalent compounds at low current-densities, but higher compounds at high current-densities, will be found in a series of papers of Grube and his colleagues.<sup>6</sup>

Some Continental investigators have used the word "passive" to cover cases where a metal passes into solution at an elevated potential to give a highly oxidised, energy-rich compound. This extension of the term "passivity" to include a condition in which metal is actually suffering corrosion has led to some confusion, and has made it necessary to seek a new word for those cases where the metal remains practically unattacked; Machu<sup>6</sup> has coined the word *korrosionspassiv* for this purpose. It seems better, however, to avoid the difficulty by using the word "passive" in its original sense to denote a condition in which corrosion is absent or at least very slow.

Whilst iron and nickel, whose oxides are soluble in acids and almost insoluble in dilute alkali, become passive easily in alkaline solution and with difficulty in acid solution, the opposite is true of metals like molybdenum and tungsten, which have oxides readily soluble in alkali but not in acid. A tungsten or molybdenum anode suffers corrosion at high current efficiency in concentrated alkali,<sup>7</sup> but easily, becomes passive in an acid bath. In general, oxidising agents favour passivity and reducing agents activity, whilst anodic treatment tends to render metal passive, and cathodic treatment to restore activity. Chlorides, bromides, and iodides, and to a lesser extent sulphate\*, militate against passivity.

**Films as Cause of Passivity.**—The relation, between passivity and the solubility of oxides in the liquid under study strongly suggests that passivity is connected with the formation of an oxide film on the metal. Although no visible change is noticed on iron when it passes from the active to the passive state, optical studies by Tronstad<sup>8</sup> (based on the principle that the presence of a thin film alters the character of polarised light reflected at a metallic surface) have shown clearly that a film develops on iron during anodic treatment under conditions leading to passivity, and is destroyed—at least in part—during the cathodic restoration of activity. With Borgmann,<sup>9</sup> he has used similar methods to study the film on iron rendered passive with nitric acid, whilst Gulbransen<sup>10</sup> has detected the loss of weight produced when iron thus passivated is heated in hydrogen—evidently owing to reduction of an oxide film. „

The main objection formerly raised against the view that passivity was due to an invisible oxide film was that iron could be rendered passive by anodic treatment in sulphuric acid, which (it was contended) would dissolve any film of oxide. Such an objection is hardly in accord with the facts, since, although some oxides are quickly dissolved by acids, the direct attack by acids upon oxides of the type  $M_2O_3$  is extremely slow. This has long been known of oxides in powder form, and is equally true of oxide films, as was brought out in experiments by U. K. Evans<sup>11</sup> on iron carrying visible films. Pure iron was heated in air to give interference tints of the first order (due to a thin oxide film), and was then placed in dilute sulphuric acid, which quickly destroyed the colours. At first, this seemed to support the view that ferric oxide in film form was rapidly soluble in acid. But when the experiment was repeated with iron carrying thicker films (showing second or higher orders of interference colours), it was found that they peeled off in the acid, and when once the films had passed out of electrical contact with the metallic basis, the solvent action practically ceased, so that the films could be kept for days in the acid without change. This suggested that the rapid destruction of the thinner films, when in contact with the metal, was due to the formation, at each crack in the film, of the short-circuited cell



The ferric oxide, being the cathode, would be rapidly reduced to the ferrous state and would pass into solution. Such an explanation was supported by the fact that tinted iron placed in sulphuric acid containing chromic acid (an oxidising agent which would prevent reduction to the ferrous state) could be kept in the acid for long periods without destruction of the colours.

The rational way to prevent cathodic reduction (due to local cells) is to submit the tinted specimen as a whole to anodic treatment. It was found that a tinted iron anode joined to the electric circuit before its introduction into the liquid (so that current started to flow as soon as the metal touched the acid) was passive from the instant of introduction; the current was devoted to the production of oxygen, and the colour due to the films remained undestroyed so long as the current continued to flow. A short interruption of current was found to be possible without destruction of colour or loss of passivity, but if the interruption exceeded a few seconds, the acid destroyed the colour by removing the film, and when the current was turned on again, the anode was found to be active, and suffered corrosion, no oxygen being produced. If the current was turned on again at the moment when the film had been removed from part of the anode but not from the whole, the anodic attack starting at the active portion undermined the remaining film, so that it peeled off. When once out of contact with the metal, it was found capable of remaining in the acid undestroyed for long periods.

These experiments show clearly that the rapid destruction of visible oxide films on iron is not caused by direct dissolution of the ferric oxide,

I but by cathodic reduction through local cells to the quickly dissolving ferrous condition. This disposes of the objection raised above. When it is remembered that anodic action favours passivity and cathodic action activity, the facts support the view that passivity is really due to an invisible ferric oxide film similar to those responsible for interference tints on heated iron, but thinner, and formed under conditions which will allow of continuous repair at any cracks which may appear in it.

**Isolation of the Films from a Passive Anode.**—The experiments on visible oxide films suggested a way of obtaining ocular evidence for the presence of oxide films on a passive iron anode. U. K. Evans<sup>12</sup> built up an electrolytic cell on a microscope stage, containing iron electrodes separated by dilute sulphuric acid; the anode was inclined to the horizontal, and the microscope was focussed upon its surface. When current was passed through such a cell, the anode at first suffered attack, but after a time it became passive, and oxygen was evolved, with cessation of corrosion. If now the current was stopped, and then very rapidly turned on again, the anode was found to be still passive, but if the cessation was prolonged, the anode was found to have become active, so that the iron suffered dissolution when the current was restarted. If the moment chosen for the restarting of the current was that at which the anode had become active on one part but was

passive over rest corrosion interfering

at the active portion undermined the film still present on the passive portion; thus, by alternate stoppage and restarting of the current, with suitable adjustment of the conditions, the film could be made to peel off. When once it was out of contact with the metallic surface, the film was perfectly visible, and was found to be capable of remaining in the acid without suffering dissolution. This research showed clearly that an oxide film is present on the passive metal, but only becomes visible when stripped from the bright basis. It showed also that the film becomes stable towards the acid, when once it is out of contact with the metallic basis, so that danger of reduction to the rapidly dissolving ferrous condition is removed.

The anodic stripping of films in sulphuric acid has the advantage that the iron salts formed cannot hydrolyse; the deposition of hydrated ferric oxide on the true oxide films, such as has always been known to occur when stripping is carried out in an aqueous solution of iodine,<sup>18</sup> is thus avoided. The objection to the aqueous iodine method has been overcome by Vernon, Wormwell, and Nurse,<sup>19</sup> who used a solution of iodine in anhydrous methyl alcohol, thus developing a valuable method suitable for the analytical study of the films isolated (v. *infra*).

**Mechanism of the Passivation.**—The passage into the passive condition has received detailed study by W. J. Müller,<sup>1\*</sup> using a horizontal anode surface carefully protected from movement in the liquid. An iron anode in sulphuric acid solution first becomes covered up with a layer of ferrous sulphate solution, which in due course becomes supersaturated and deposits crystals of ferrous sulphate identifiable



in the polarising microscope. These crystals screen the greater part of the surface, so that, notwithstanding the fact that the total current flowing is diminished as the crystalline layer extends, the current density on the unscreened part steadily rises. When the current density has become very high, other reactions (which do not occur at low current density, since they require more energy than the passage of iron into the solution as ferrous sulphate) begin to take place to a small extent; these include the formation of oxide films and even the evolution of oxygen. When once a film has formed over any point, it will interfere with passage of iron into the solution as ferrous sulphate, so that oxide film formation, once started, spreads over the whole surface; subsequently the only possible reaction is the evolution of oxygen, which will then sweep away the microscopic crystals of ferrous sulphate, so that the surface, which is often dull during the process of passivation, becomes bright again.

Miiller has studied the dying away of current with time experimentally, and has compared his results with mathematical equations obtained by the combination of well-established laws of electrochemistry. Two equations can thus be developed,<sup>16</sup> the first based on the assumption that a film of constant thickness is spreading sideways over the metal, and the second on the assumption that a film occupying a constant fraction of the electrode area is growing in thickness. The two equations are

$$i_1 - i_0 = A \left\{ \frac{1}{i_0} - y - atfo \right\} \log \left\{ \frac{i_0 - i}{h} \right\} \quad m$$

$$i_1 - i_2 = B \left\{ W - \frac{1}{h^2} \right\} \quad \bullet \bullet \quad (2)$$

where  $i_0$ ,  $i_1$  and  $i_2$  are the currents at times 0,  $t_x$  and  $t_2$ , respectively, and  $G$ ,  $A$ , and  $B$  are constants. Miiller found that during the passivation of anodes consisting of different metals (e.g., iron, copper, and lead), equation (1) was obeyed during the opening stages, and equation (2) during the later stages. This indicates that the film starts at certain points on the surface, and spreads sideways, the thickness being constant, until the greater part of the metal is covered; subsequently it begins to grow in depth.

**Time of Passivation.**—The time needed for the attainment of passivity has been studied by Miiller and others. It is shorter at high current densities than at low ones, is lengthened by stirring of the liquid, and depends greatly on the previous history of the iron and on the nature of the liquid. It is much longer in acid solution than in alkaline solution; in neutral solution it is shortened by any preliminary treatment likely to cause even a discontinuous oxide film on the metal.

Other studies of the time of passivation have been carried out by Shutt and Walton,<sup>17</sup> who used a vertical gold electrode in potassium chloride or hydrochloric acid under conditions of violent stirring. Movement in the liquid prevents the accumulation of a supersaturated layer and thus militates against passivation. It was found that under these conditions there was a limiting current density ( $i_0$ ) below which passivity was never produced, however long the

experiment was continued. At any higher current density ( $i$ ), the time of passivation ( $t_p$ ) was given by the equation

$$t_p(i) = \frac{Q}{i - i_0} \quad \dots \quad (3)$$

where  $Q$  is a constant, which in the stronger solutions was proportional to the chlorine ion concentration, whilst  $i_0$  was also proportional to the chlorine ion concentration over a wide range of conditions. Armstrong and Butler<sup>18</sup> found a similar relation for a gold anode in an unstirred solution, whilst Roberts and Shutt<sup>19</sup> discovered that the same equation determined the time at which a chromium anode begins to dissolve as chromic acid at an elevated potential—a change which (whether or not it should be referred to as "passivation") has, as indicated above, much in common with the setting in of true passivity on iron or gold.

**Other Views of Passivity.**—The phenomena of passivity, appear to be satisfactorily explained by the formation of films, and the existence of such films on metal rendered passive either by anodic treatment or by immersion in oxidising agents is no longer in doubt. Nevertheless numerous other theories of passivity have been, and continue to be, put forward. According to one group of theories, metals are in their nature passive unless they contain hydrogen; the activity engendered by cathodic treatment is attributed to the introduction of hydrogen, and the passivity consequent on anodic treatment is ascribed to the removal of the same substance.<sup>20</sup> Others ascribe passivity to a film of oxygen rather than oxide,<sup>21</sup> whilst several theories<sup>22</sup> have been advanced which associate passivity with electronic rearrangements within the atoms.

**Periodic Passivity and Pulse Transmission.**—Certain phenomena which have always awakened much interest, although even to-day their mechanism is not completely understood, are met with under conditions intermediate between those which favour activity and passivity, so that a small change can tip the balance between one state and the other. These include "periodic passivity," which is discussed in detail by Hedges,<sup>23</sup> and the transmission of activity or passivity along wires, as in the experiments described by Heathcote<sup>24</sup> and Lillie.<sup>25</sup>

**Passivity as a Factor in Choice of Industrial Materials.**—The avoidance of corrosion in chemical industry depends essentially on the choice of materials which will maintain themselves passive in the prescribed environment, or on the adjustment of the environment set as to render passive the materials which, for reasons of strength or economy, are forced on the user. There are certainly some materials, like gold and platinum, which are resistant to corrosion because they have little affinity for oxygen and other non-metals. There are, however, others, like aluminium, which possess great affinity, but which, despite the large free-energy decrease connected with their corrosion reactions, actually suffer little or no attack owing to the facility with which they cover themselves with protective oxide films. In exceptional circumstances (e.g., in presence of mercury), where the oxide film formed on aluminium assumes a

non-protective form, the rate of reaction may attain a rapidity which is almost sensational.

The word "passivity" is, however, seldom used in connection with such materials as aluminium, being reserved—perhaps inconsistently—to cases where the metal passes easily between the active and passive conditions. Clearly such a state of affairs will be unwelcome to the industrial chemist. Sometimes materials which laboratory experiments might seem to indicate as suitable to an environment are found in service to be unreliable. In the laboratory, iron is violently eaten away by dilute nitric acid, but if introduced into concentrated acid, it will, after mild incipient action, become passive. In industry, the exposure of a large surface of iron even to highly concentrated acid may be fraught with danger, since the attack may start at some surface defect or site of inclusion, and, since any incipient action which involves loss of oxides of nitrogen will locally increase the ratio  $H_2O:N_2O_5$ , there is a chance that the attack, once started, may extend over the whole surface. The danger will be less where the "water activity" is artificially depressed, and it is interesting to note that nitric acid containing sulphuric acid can often be used industrially in contact with steel, where nitric acid alone would evolve risks of disastrous corrosion.

Since the breakdown of passivity in nitric acid is connected with reduction from the trivalent to bivalent state, it would seem rational to adopt—for use in contact with that acid—a metal which is invariably trivalent. It is significant that aluminium, where reduction to the bivalent state is excluded, is hardly affected by nitric acid of compositions which would violently attack steel, and is indeed employed in industry for handling the higher concentrations. Even where (as around 30% concentration) the metal is attacked too quickly to be attractive to the manufacturer, the rate of corrosion is far slower than that set up by the same acid on iron, the destruction per year being similar to what would occur in a few hours on mild steel. However, the presence of a small amount of chloride greatly increases the attack on aluminium, probably owing to the great solubility of aluminium chloride. Inclusions in the metal also stimulate attack. The use of high-purity aluminium will in general greatly increase resistance to corrosion, provided care is taken to avoid introducing contamination during rolling or fashioning.

The introduction into iron of an element, like chromium, in which the bivalent state is far less stable than the trivalent, might be expected to improve its behaviour, and the resistance of the stainless steels to nitric acid of concentrations which would rapidly eat into ordinary steel may perhaps be explained<sup>26</sup> by the fact that the chromium in the mixed oxide films,  $(Fe,Cr)_2O_3$ , stabilises the trivalent condition and prevents reduction. The resistance of stainless steel to water containing oxygen is probably due to the fact that the metal passes directly into the form of the mixed sesquioxide,  $(Fe,Cr)_2O_3$  (perhaps hydrated), which builds a protective film over the surface, whereas iron free from chromium first passes into the water in the bivalent con-

dition and is oxidised at a slight distance to non-protective rust. Forrest, Roetheli, and Brown<sup>27</sup> found that water containing oxygen attacks film-free stainless steel at roughly the same rate as it attacks film-free iron, but, whereas the attack on the pure iron continues unchecked, that on the stainless steel falls off as a film develops.

The isolation and analytical examination of the protective film from stainless steel of the austenitic chromium-nickel class has been carried out by Vernon, Wormwell, and Nurse,<sup>28</sup> using their alcoholic iodine technique. The oxide film contains iron and chromium, but practically no nickel, and the ratio of chromium to iron in the film substance is always higher than in the metal, and increases with the polishing of the surface, even though the polishing agent contains no chromium; if chromic oxide has been used in the preparation of the surface, the film becomes still richer in chromium.

The alloys mentioned are not resistant to non-oxidising acids, but attack by such reagents can be greatly reduced if the material contains molybdenum—which is clearly related to the fact, mentioned above, that molybdenum, although active in alkalis, tends to become passive in acids.

Passivity as a Factor in Water-treatment.—Among the most efficient soluble inhibitors used for rendering cooling-waters non-corrosive are sodium and potassium chromates. The sodium salt is of course the cheaper; sometimes the dichromate is actually used, along with sufficient alkali to convert it to  $Na_2CrO_4$ . The protection is due to the fact that any iron salts formed at the numerous discontinuities in the invisible oxide film which exists on any steel surface after exposure to air are precipitated, as a mixed ferric-chromic hydroxide, in physical contact with the metal, repairing the discontinuities; thus corrosion is prevented so long as the water continues to contain sufficient chromate to carry out repairs at points of spontaneous cracking. The film on iron in a chromate-treated water contains both ferric and chromic oxides, the content of chromium diminishing with the period of exposure to air prior to introduction into the water, as shown by the analyses of Hoar.<sup>29</sup>

Unfortunately here, as always, chlorine ions militate against passivity, and the chromate concentration needed to prevent rusting increases with the chloride content, as well as with the temperature of the water. It is impossible to specify a chromate concentration which will ensure that a water becomes non-corrosive, since this depends on the design of the plant; the additions must be increased if there are inaccessible places where the water is stagnant, but can be reduced if the water is kept in rapid flow at all parts in the system. If the chromate concentration is insufficient, corrosion will occur locally and may be more intense than if no chromate had been added, since—for electrochemical reasons<sup>30</sup>—the area suffering corrosion will be diminished more rapidly than the total attack, so that the corrosion per unit area will increase.

The danger of local exhaustion of chromate—

with consequent intense corrosion—is greatest at remote corners and crevices, and in places where debris, including particles of scale or rust, can collect. Other soluble inhibitors, such as silicates and phosphates, are also liable to cause intensification of attack, if added in insufficient amount. The provision of a system of inhibitive water-treatment which is both safe and efficient is one of the great needs of the day; some progress has been made by Thornhill,<sup>81</sup> but a complete solution of the problem cannot yet be claimed.

**Passivity as a Factor in protective Painting.**—The fact that certain paint systems may prevent corrosion of steel when the coats are not water-tight, and sometimes when they contain visible discontinuities, is attributable to the use of pigments which maintain passivity. Here again chromates are among the most efficient. Highly soluble chromates would, of course, be washed out of a paint, whilst highly insoluble ones would fail to maintain passivity; chromates of intermediate solubility are employed, notably zinc chromate, usually in admixture with iron oxide. Lead pigments, including not only red lead but also metallic lead and certain lead alloys, are also much used as anti-corrosive pigments in the priming coat of paints, and probably act by the formation of lead soaps, which are adsorbed on the metal. The fact that they do serve to render iron passive is suggested by the potential studies of Burrows and his colleagues,<sup>82</sup> whilst their power of diminishing the corrosion rate is shown by the measurements of Lewis,<sup>88</sup> who found that iron shaken in a tube containing water and air suffered much less attack if the water contained a suitable lead pigment than if an inert powder (or no powder at all) was present.

**Passivity in Electroplating.**—Another situation where passivity attains industrial importance is in plating; here it is generally required that the anodes shall dissolve smoothly so as to keep the bath replenished with the metal which is being deposited. Consequently passivity is an undesired phenomenon, and efforts are made to avoid it by the introduction of chlorides, by the regulation of pH at a suitably low value, or by the use of special anodes containing inclusions which interfere with the maintenance of a continuous film.

#### REFERENCES.

1. T. Schönbein, Phil. Mag. 1836, [ill], 9, 53.
2. M. Faraday, *ibid.*, p. 57.
3. E. P. Schoch and C. P. Randolph, J. Physical Chem. 1910, 14, 719.
4. L. W. Bennett and W. S. Burnham, Trans. Electrochem. Soc. 1916, 21, 252.
5. G. Grube, H. Gmelln, R. Heidinger, and L. Schlecht, Z. Elektrochem. 1920, 26, 459; 1926, 32, 70; 1927, 33, 389.
6. W. Machu, Österr. Chem.-Ztg. 1933, 36, 44.
7. M. de Kay Thompson, A. L. Kaye, and C. W. Rice, Trans. Electrochem. Soc. 1932, 62, 255; 1935, 67, 71.
8. L. Tronstad, Z. physikal. Chem. 1929, 142, 241; 1932, 158, 369; Trans. Faraday Soc. 1933, 29, 502.
9. L. Tronstad and C. W. Borgmann, *ibid.* 1934, 30, 349.
10. E. A. GulUansen, Trans. Electrochem. Soc. 1930, 35, 40.
11. U. R. Evans, J.C.S. 1930, 480.
12. U. R. Evans, Nature, 1930, 126, 130.
13. U. R. Evans, J.C.S. 1927, 1024.
14. W. H. J. Vernon, F. Wormwell, and T. J. Nurse, *ibid.* 1939, 621.

15. W. J. Müller, Trans. Faraday Soc. 1931, 27, 737;

16. Begründung, Verlag Chemie, 1934.

17. For simplified proofs, m U. B., Evans, "Metallic Corrosion: Passivity and Protection," Arnold, 1947, pp. 61-65.

18. W. J. Shutt and A. Walton, Trans. Faraday Soc. 1932, 28, 740; 1934, 30, 914.

19. G. Armstrong and J. A. V. Butler, *ibid.* 1934, 30, 1173.

20. R. H. Roberts and W. J. Shutt, *ibid.* 1938, 34, 1455.

21. G. C. Schmidt, *ibid.* 1914, 9, 257.

22. W. H. Cone and H. V. Tartar, J. Amer. Chem. Soc. 1937, 59, 937; see, however, R. S. Crog and H. Hunt, Trans. Electrochem. Soc. 1941, 79, 145.

23. A. S. Russell, Nature, 1925, 115, 455; 1926, 117, 47; H. B. Uhlig and J. Wulff, Trans. Amer. Inst. Min. Met. Eng. 1939, 135, 494; 1940, 140, 357; Corr. Mat. Prot., July-Aug. 1947, p. 10.

24. K. S. Hedges, J.C.S. 1926, 1533, 2580, 2878; also book, "Physico-Chemical Periodicity," Arnold, 1926.

25. H. L. Heathcote, J.S.C.I. 1907, 26, 899.

26. R. S. Lillie, J. Gen. Physiol. 1920, 3, 107, 129.

27. U. R. Evans, Trans. Faraday Soc. 1944, 40, 129.

28. H. O. Forrest, B. E. Rotheli, and R. H. Brown, Ind. Eng. Chem. 1930, 22, 1197.

29. W. H. J. Vernon, F. Wormwell, and T. J. Nurse, J. Iron and Steel Inst. 1944, 150, 81P.

30. T. P. Hoar and U. R. Evans, J.C.S. 1932, 2476.

31. U. R. Evans, Trans. Electrochem. Soc. 1936, 69, 213.

32. R. S. Thornhill and U. R. Evans, J. Iron and Steel Inst. 1942, 146, 73P.

33. R. M. Burns, H. E. Harling, and R. B. Gibney, Trans. Electrochem. Soc. 1936, 69, 169; 1939, 76, 287.

34. K. G. Lewis and U. R. Evans, J.S.C.I. 1934, 53, 297.

35. J. E. O. Mayne, *ibid.* 1946, 65, 196.

U. R. E.

**PATCHOULI ALCOHOL**,  $C_{15}H_{26}O$ , m.p. 56°, b.p. 140°/8 mm.,  $n_D^{20}$  1.4924,  $n_D^{25}$  1.4829,  $[a]_D^{20}$  -97.42°. Occurs in oil from *Pogystemon patchouli*.

J. L. S.

**PATINA** (v. Vol. HI, 373a, 392a, c).

**PATRONITE**. An inhomogeneous mineral substance, approximately  $VS_4$ , containing about 25% of vanadium. The name was originally given to a mixture of vanadium-bearing substances associated with a steeply-inclined layer of an asphaltite, called *grisguaita*, from which the patronite may have been derived. Patronite is soft and dark-green in colour, and has a dull, earthy lustre. It was until recently the principal ore in the famous vanadium mine at Minasragra, near Cerjo de Pasco, Peru, the world's foremost producer of vanadium. Patronite has now been superseded as the chief ore at Minasragra by other complex vanadium minerals. Between 1939 and 1941, this mine exported annually about 15,000 tons of vanadium ore, with a vanadium content of approximately 1,100 tons.

D. W.

**PATULIN**. Patulin is the name given by Raistrick (Lancet, 1943, ii, 625) to an anti-bacterial substance produced by the mould *Penicillium patulum* Bainier. It is also produced by several other moulds, and has been shown to be identical with "claviformin," isolated by Chain, Florey, and Jennings (Brit. J. Exp. Path. 1942, 28, 202) from the metabolism solution of *Penicillium claviforme*; with "clavatin" and "clavacin" isolated by Bergel, Morrison, Moss, Klein, Rinderknecht, and Ward (Nature, 1943, 152, 750), and by Waksman, Homing, and Spencer (Science, 1942, 96, 202), and Hooper, Anderson, Skell, and Carter (*ibid.* 1944, 99, 16) from the metabolism solution of

*Aspergillus davatus*; and with "expansin" isolated by Nauta, Oosterhuis, Linden, Van Duyn, and Dienske (Bee. trav. chim. 1945, 64, 254) from the metabolism solution of *Penicillium expansum* Westl.

Patulin crystallises from ether in colourless prisms or plates, m.p. 111°. It forms a *monoacetyl* derivative, m.p. 118°, a *phenylhydrazone*, m.p. 152-153°, and an *oxime*, m.p. 152-155°. As the result of chemical degradation it was identified as anhydro-3-hydroxymethylenetetrahydro- $\gamma$ -pyrone-2-carboxylic acid by Birkinshaw, Bracken, Michael, and Baistrick (Lancet, 1943, ii, 625). Additional evidence for this structure was advanced by Bergel, Morrison, Moss, and Binderknecht (J.C.S. 1944, 415) who also showed that the substance behaved as a mixture of several tautomeric forms (I-IV). Its chemical reactions are unexpectedly complicated.

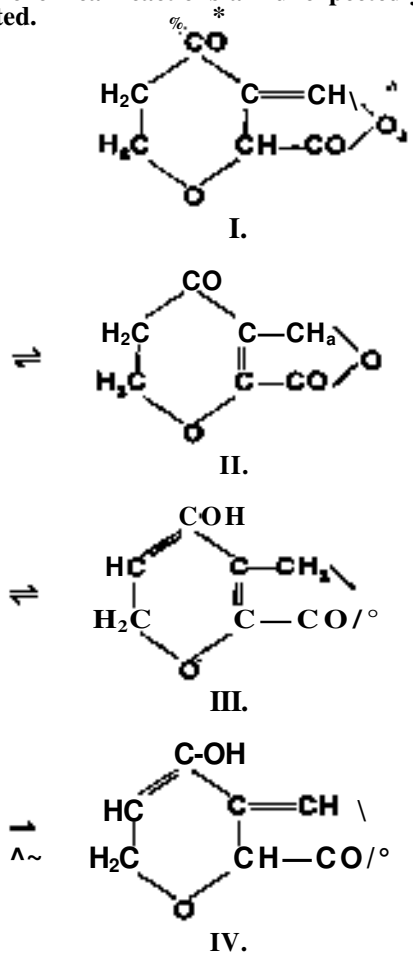

The evidence advanced by Birkinshaw *et al.* for formula (I) was as follows. On boiling with 2% sulphuric acid, it yielded formic acid and tetrahydro- $\gamma$ -pyrone-2-carboxylic acid, which established the presence of the pyrone ring and the position of all the carbon atoms except one. With concentrated hydriodic acid,  $\gamma$ -keto- $\epsilon$ -iodo- $\eta$ -hexanoic acid was formed and, on catalytic hydrogenation, followed by further reduction with concentrated hydriodic acid and red phosphorus, 0-methyl- $\gamma$ -hydroxy- $\eta$ -hexanoic acid and  $\beta$ -methylcaproic acid. These reactions fixed the relative positions of all the carbon atoms, and

led to (I) as the most probable formula. Bergel *et al.* however, pointed out that tetrahydro- $\gamma$ -pyrone-2-carboxylic acid had only been obtained from patulin in a yield of 10%, so that additional evidence was desirable to confirm the presence of the pyrone ring. They were able to provide the following further data in support of Baistrick's suggested formula. When treated in ethanol solution with hydrogen chloride, patulin gave an oil which, on hydrolysis with dilute acid, was converted into a crystalline ketochloro-acid,  $C_7H_9O_2Cl$ . This on hydrogenation gave a chlorine-free keto-acid,  $C_7H_{10}O_4$ , which on treatment with hydriodic acid was converted into a diiodo-acid,  $C_7H_{10}O_3I_2$ . This on reduction yielded  $\gamma$ -keto- $\beta$ -methyl- $\eta$ -hexanoic acid (IX). Hydrogenation of patulin, followed by treatment with hydrobromic acid, yielded a bromo-compound which was converted by reduction into 0-n-propylbutyrolactone. The formation of this compound and of the acid (IX) established the relative positions of all the carbon atoms, whilst the position of the fourth oxygen atom was established by a consideration of the intermediates leading to the formation of (IX). The diiodo-acid was presumed to be ac-diiodo- $\gamma$ -keto- $\beta$ -methyl- $\eta$ -hexanoic acid (VIII) and the mono-keto acid, 3-methyltetrahydro- $\gamma$ -pyrone-2-carboxylic acid (VII). The chloro-acid was formulated as 3-chloromethylenetetrahydro- $\gamma$ -pyrone-2-carboxylic acid (VI), whilst the oil from which it was formed was assigned the structure (V), which must have been derived from the tautomeric form (IV) of patulin.

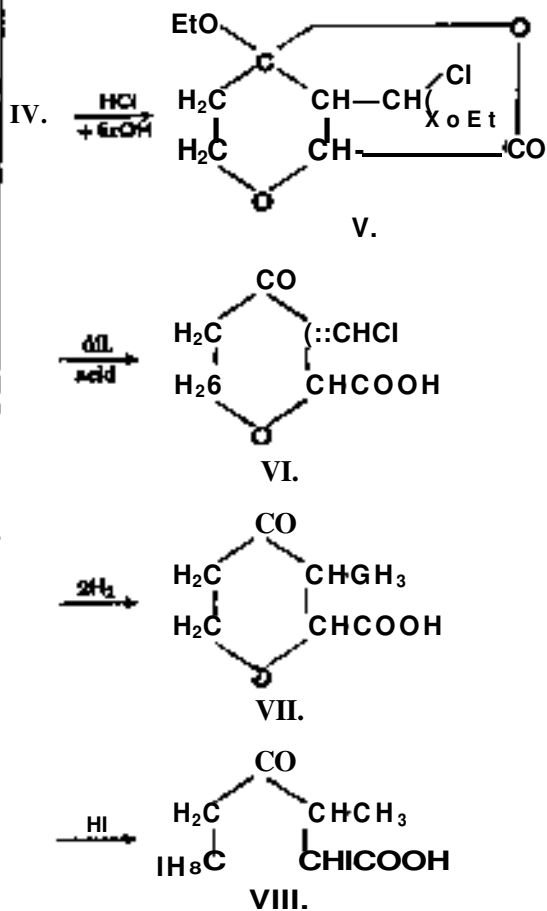

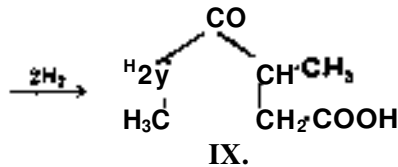

Attempts to synthesise patulin have been unsuccessful (*c.* Attenburrow, Elks, Elliott, Hems, Harris, and Brodrick, J.C.S. 1945, 571; Borrows and Hems, *ibid.*, p. 577).

Patulin completely inhibits the growth of *Staphylococcus aureus* at a dilution of 1 in 64,000 to 128,000 and is equally effective against other Gram-positive and a number of Gram-negative organisms. This strong generalised anti-bacterial activity prompted Gye (*Lancet*, 1943, ii, 625) to test patulin in the treatment of the common cold, and preliminary observations suggested that it produced rapid relief in this condition. These findings were supported by Hopkins' observations (*ibid.*) in a controlled trial on a number of volunteers, the results being apparently statistically significant. In a subsequent investigation, however, by Stansfeld, Francis, and Stuart Harris (*ibid.* 1944, ii, 370) no significant effect was observed on the duration or severity of the common cold, and no satisfactory reason has ever been put forward as to why these two sets of clinical trials should have given results diametrically opposed to one another.

Attempts to use patulin for the treatment of bacterial infections in experimental animals were also unsuccessful, as the substance proved to be very toxic. Its pharmacological properties were investigated by Broom, Billbring, Chapman, Hampton, Thomson, Ungar, Wien, and Woolfe (*Brit. J. Exp. Path.* 1944, 25, 195). The most striking change produced by lethal doses of patulin was severe lung oedema, and even small doses injected subcutaneously caused oedema not confined to the site of injection but occurring throughout the body; this led to hsemocoagulation. Patulin also had a local irritant action on the conjunctiva, arrested the ciliary movement on mucous membranes, stopped the growth of fibroblasts in tissue cultures, and inhibited wound healing. Sub-toxic doses had a marked anti-diuretic action. Patulin, therefore, is valueless as a therapeutic agent, both for internal use and for local application.

Patulin has a marked lethal action on certain fungi and has been tested as a fungicidal agent in the protection of plant seedlings against fungus attack.

F. A. R.

#### PÄULI'S PRINCIPLE (v. VALENCY).

**PAW-PAW.** The name commonly given in England to the Papaya (*Carica papaya* L., or *Papaya vulgaris* B.C.), not to be confused with the American Paw-Paw or Custard-apple *(v. infra)*.

The papaya is a melon-like fruit, approximately 1 lb. in weight, and is eaten raw or cooked, or is converted into pickles and preserves. It is the commercial source of West Indian papain (*v. this Vol.*, p. 215c) which occurs in the latex. The latter, after tapping, readily coagulates on exposure, and is rapidly

sun-dried. The edible flesh of the fruit, constituting approximately two-thirds of the total weight, has the following analysis (Adrano, *Philippine Agric.* 1926, 14, 57): Solids 11-12, protein 0-3-1-2, fat 0-17-0-24, fibre 1-66, ash 0-53%. Thompson (*Hawaii Agric. Exp. Sta. Ann. Rept.* 1914) also records the ripe flesh to contain: reducing sugars (largely glucosa and fructose) 8-99, sucrose 0-54, organic acids (as citric acid) 0-15%. The ripening process is associated with a steady increase in reducing sugar content but with little alteration in those of sucrose or acid. According to Bagoaisan (*Philippine Agric.* 1932, 21, 53) the fruit contains 1-27% (dry weight) of phytin (*v. Vol. VI*, 495c).

The Custard-apple (American Paw-Paw) is the fruit of a native American species, black-skinned and yellow-fleshed, highly valued for desert or as ingredient of beverages and preserves. Winton ("*Structure and Composition of Foods*," Vol. II) quotes the following percentage analysis of the edible portion (approximately three-quarters of the total weight) of the fruit:

Water.	Protein.	Fat.	Nitrogen-free extract.	Reducing sugars.	Sucrose.	Ash.
76-6	5-2	0-9	16-8	5-9	2-7	0-4

A. G. Po.

**PEA. *Pisum sativum* or *P. arvense*.** A leguminous plant common to moderate climates almost throughout the world. The green immature seeds form the common domestic vegetable; the fully ripened and dried seed is threshed and stored for human food or for the winter feeding of cattle. The leafy part of the plant may be hayed and used as a stock feed for which its relatively high nitre, phosphorus, and calcium contents are of value. Canned (green) peas, in recent years, have become an important item of diet. A soft-podded variety (*P. sativum* var. *saccharatum* or *P. sativum gulosum*), the French "pois goulus," of which both seed and pod are edible is favoured in some parts of the European continent and in America. The innumerable varieties and hybrids of peas render botanical classification impracticable but in general the wrinkled surfaced (when dry) garden pea is commonly described as *P. sativum*, and the smooth (field) pea as *P. arvense*.

As typical percentage analyses of peas, the following may be quoted:

	Solids.	Protein.	Fat.	Sucrose.	Starch.
iPetit pois	14-2-18-8	3-4-4-4		0-7-0-9	5-6-8-5
iMarrowfat	22-2-27-5	5-1-6-7		0-4-0-9	1-8-12-9
*Dried	86-4	23-4	10		

	Pentose.	Total N-free extract.	Fibre.	Ash.
iPetit pois	0-7-0-9		1-7-2-3	1-0-1-8
iMarrowfat	1-0-1-0	16-9	1-0-1-6	1-5-2-6
*Dried		52-7	5-6	2-8

U.S. Bur. Chem. : 1944, 1904, Bull. : 8? Exp. st B. 1909; Bnn. 126

The non-protein nitrogen may amount to 25% of the total nitrogen in very young peas and averages 8-12% in the more mature stage at which they are usually marketed. Osborne and Campbell (J. Amer. Chem. Soc. 1896, 18, 583) separated the pea proteins, which consist mainly of two globulins, legumin and vicilin, with approximately 10% of an albumin, legumelin. There are also present a proto- and a deuteroproteose and small amounts of choline and trigonelline. A detailed examination of the proteins is recorded by Osborne and Heyl (J. Biol. Chem. 1908, 5, 187).

The nitrogen-free extract of peas includes an average of starch 68, dextrin 10.5, and pentosans 4%. O. Kellener ("Scientific Feeding of Animals," 1926) records analyses of the whole plant at different stages and of the seed and milling offals as commonly graded for stock feeding (all values, % k \*).

	Water.	Protein.	Fat.	N-free extract.	Fibre.	Ash.
Green plant						
Hay (cut at flowering)	84.6	4.0	0.5	6.1	4.5	1.4
Hay (cut ripe)	16.7	14.3	2.6	34.2	25.2	7.0
Seed (air-dry)	13.6	9.0	1.6	33.7	35.5	6.6
Whole	14.0	22.6	1.6	53.7	5.4	2.8
Husk	1.20	7.8	1.2	31.9	44.7	2.0
Bran	11.7	16.8	1.7	46.2	20.1	3.5

The seed yields 1-2% of a pale yellow oil containing considerable proportions of lecithin and phytosterol. Recorded characteristics of the oil include: saponification value 188.5, neutral fat 58.7 (ether), 74 (petroleum), total fatty acids 87.6, free fatty acids 1.6, lecithin 27.4 (ether), 9 (petroleum), unsaponifiable matter 7.7%.

From numerous published records\* of the vitamin content of peas (per 100 g.) the following are representative: \*

	Vitamin-B <sub>1</sub>	Thiamin, PS.	Bioflavin, %g	Ascorbic acid, mg.
Fresh	600-3,300	350-800	50-250	15-30
Frozen	400-1,400	300-600		8-25
Canned	400-1,100	80-800		5-20

The ash of peas comprises:

K <sub>2</sub> O	Na <sub>2</sub> O	CaO	MgO	P <sub>2</sub> O <sub>5</sub>	SO <sub>3</sub>	SiO <sub>2</sub>	Cl
8	1.0	60	80	36.4	3.5	00	1.5

The minor mineral constituents include: Fe 60, Mn 1.0-1.4, Cu 4-11, Zn 34, As 0.26; B 84 mg. per kg. T. Y. Lo (Food Res. 1945, 17, 308) reports that the carotene content of Peas is increased by supplying small amounts of zinc or nickel to the plants.

A. G. Po. PEACH. The fruit of *Prunus persica*, the original species of which were probably native to Persia and Southern China. Modern varieties are commonly classed as "cling stone" or "free stone" types, according to the manner of attach-

ment or ease of detachment of the stone (or "pit") and the flesh. The fruit is eaten raw or is canned for transport and storage. The larger American-grown varieties average 150-200 g. in weight, and European-grown types 50-70 g. The stones represent approximately 6 and 3-5% of the total weight of the respective types, and the edible pulp includes 75-80% of juice.

The percentage composition of the edible flesh of the fruit is as follows:

	Total solids.	Protein.	Acids (as malic).
American	13-21	0.35	0.7
European	11-17	0.8-1.1	0.5-1.1

	Sucrose.	Reducing sugars.	Tannin.
American	5-7	20	
European	20-100	2-0.7-0	0.06-0.22

A typical analysis of the separated juice (p 1-042) records the following constituents in g. per 100 c.c.

Solids.	Protein.	Adds (as malic).	Reducing sugars.	Sucrose.	Tannin.	Ash.
10-3	0.4	10	3.4	3.5	0.12	0.46

The acids present are mainly malic and citric acids, the proportions of which vary enormously in fruit from different sources (Muttelet, Ann. Falsif. 1922, 15, 453)..

The ripening process in peaches is associated with a steady increase in both sucrose and reducing-sugar contents (percentage and absolute amounts), the disappearance of starch, and the transformation of protopectin into pectin without appreciable change in the total amount of pectinous matter present.

The stones yield a fatty oil, commercially known as "peach-kernel oil" amygdalin, and a protein, anandrin (Osborne and Campbell, J. Amer. Chem. Soc. 1896, 18, 609).

The odoriferous principle of peaches examined by Power and Chestnut (*ibid.* 1921/43, 1725; 1922, 44, 2966), consists largely of esters (formate, acetate, valerate, and caprylate) of linalool. An appreciable amount of acetaldehyde and a trace of cadinene are also present.

The vitamin contents of peaches vary enormously according to source. The following ranges of values (per 100 g.) have been recorded:

	Vitamin-B <sub>1</sub>	Thiamin, PS.	Bioflavin, %g.	Ascorbic acid, mg.
Fresh	300-3,000	30-120	7-60	2-18
Canned		30-90		1.5

Mineral constituents of the ash of peach flesh include: K<sub>2</sub>O 0.20-0.32, CaO 0.01-0.36, MgO 0.17-0.20, P<sub>2</sub>O<sub>5</sub> 0.046-0.053% of the fresh material, the total ash being 0.3-0.6%. Of the minor elements reported data show Fe 3-6, Al 8-8, Cu 2-7, and Zn 0.2 mg. per kg. fresh weight.

PEAR. The fruit of *Pyrus communis* originally occurring in temperate regions of Europe and western Asia. Many varieties are now grown including hybrids with the Japanese sand pear (*P. serotina*). The small sour pear used in France and elsewhere for the making of perry is probably derived from the "snow pear" (*P. nivalis*). Dessert pears are normally picked while still hard and green and allowed to ripen in darkness. A typical analysis of green pears shows: H<sub>2</sub>O 83.9, protein 0.56, fat 0.79, N-free extract 11.5, fibre 2.7, ash 0.6.

Changes in composition consist mainly in a steady increase in sugar content and a smaller increase in acidity as shown in the following data:

	Water	Acids	Re- ducing sugars	Su- crose	Tan- nin	Ash
Green	80.0	0.4	6.8	0	0.01	0.14
Ripe	87.5	1.0	12.4	5.8	0.1	0.37

Pear juice (p 1\*052) is reported to contain (g. per 100 c.c.):

Solids	Pro- tein	Acid (as malic)	Re- ducing sugars	Su- crose	Tan- nin	Ash
13.3	0.28	0.75	7.8	2.0	0.17	0.35

(Windisch and Schmidt, Z. Unters. Nahr- u. Genussm. 1909, 17, 584). Malic and citric acids are the principal acids found. Even in the immature state pears contain appreciable proportions of acetaldehyde, which increase considerably as the fruit ripens. Juice of green fruit may contain 18-52 mg. of acetaldehyde per litre, the value rising to 200 mg. in over-ripe (sleepy) fruit.

Pears are commonly conserved by drying or by canning and the following indicates average analyses of the processed fruit:

	Water	Protein	Fat	Carbo- hydrates	Ash
Dried pears	16.5	2.8	2.4	72.9	2.4
Canned	81.1	0.3	0.3	18.0	0.3

Hüber (Landw. Versuchs.-Stat. 1911, 75, 443) records the following analysis of dried pear seed:

	Protein	Fat	Lecithin	Total sugars (as invert)
Whole seed	39.4	25.2	0.8	1.6
Kernel	51.8	33.1	1.04	5.5
Hull	11.4	7.1	0.06	5.9

	Pentosans	Fibre	Ash
Whole seed	6.7	7.15	4.19
Kernel	3.4	2.14	5.04
Hull	14.3	18.48	2.31

Characteristics of the seed oil are: n<sub>D</sub><sup>25</sup> 1.4727, saponification value 197, iodine value 126, acid value 2.3, unsaponifiable matter 0.5%.

Pear leaves contain approximately 1% of arbutin which, on hydrolysis, yields quinol, small quantities of which have been detected in pear buds.

Serfert (*ibid.* 1894, 45, 29) reported the presence of a wax (m.p. 68°) in the rind of pears. The vitamin contents of pears (per 100 g.) are reported by various authorities as: Vitamin-A less than 50 I.U., thiamin 2-50 fig., riboflavin 7-30 fig., and ascorbic acid 1-11 mg. (canned fruit 0.5-2.0 mg.).

The mineral constituents of the fruit (total ash 2.5-3.5%) include: K<sub>2</sub>O 1.5, Na<sub>2</sub>O 1.3, CaO 0.25, MgO 0.2, P<sub>2</sub>O<sub>5</sub> 0.4, SO<sub>3</sub> 0.2, SiO<sub>2</sub> 0.1%, together with Fe 3, Cu 2.2, Zn 16, and As 0.7 mg. per kg. of fresh material.

A. G. Po.

PEARL (\*, Vol. VIII, 23Si).

PECTIN. Under the heading "pectic materials" or "pectins" are included groups of substances, the complex nature of which has made it difficult to establish their composition and constitution, and to decide whether or not they are to be regarded as chemical entities. They have long been recognised as constituents of the cell walls of plants and were first isolated as long ago as 1790 by Vauquelin (*Ann. Chim. Phys.* 179C, 5, 92), who also showed that the formation of jellies with certain fruit juices and sugar was due to the presence of pectin in the juice. This ability to form jellies with sugar is the basis of the main industrial use of pectin preparations; the changes undergone by pectins in the ripening of fruit, storing of vegetables and the retting of flax, to mention only a few examples, have made essential a detailed study of the chemistry and biochemistry of the pectic materials.

Pectin, as normally isolated from plant material, is a mixture of polysaccharides, three of which have been identified and characterised. These are: *pectic acid*, present to some extent in fruit and methylated and responsible for the acidity and jelling properties of pectin; *araban*, hydrolysis of which gives rise only to D-arabinose; and a *gdactan*, built up solely of D-galactose residues. Other polysaccharides may also be present in pectin, and some authors claim to have isolated D-fucose and D-xylose from the products of hydrolysis of various pectins. The older literature contains many references to substances such as "metapectic acid," "digalacturonic acid," etc, but it now seems certain that these products were not chemical entities and consisted of mixtures of polyuronides or of their degradation products.

The constitution of the acidic component of pectin has been the subject of many investigations, but only recently has proof been obtained that pectic acid is a polymer of high molecular weight built up of D-galacturonic acid residues. One of the most difficult problems here, as also with pectic materials in general, is the isolation of the pure polysaccharide in a form suitable for examination. Owing to the high molecular weight and the colloidal nature of the polymers a complete separation of the



pectic acid, from adsorbed araban and galactan is difficult to achieve. In addition, the pectic acid appears to be present in the plant in an insoluble form, more especially in the early stages of growth. There is some evidence that this insolubility is due to the combination of the carboxyl groups of the pectic acid with other polymers such as galactan, araban, and cellulose (Henglein, J. für makromolekulare Chemie, 1943, 1, 121), or to the presence of insoluble magnesium or calcium pectate. The insoluble calcium salt of pectic acid is used as a method of isolation and estimation of pectic acid.

Ehrlich and Saurez independently showed that pectic acid is built up of d-galacturonic acid (I) residues, and that either "pectinase" (from the mould *Penicillium ehrlicii*) or mineral acid, could be used to bring about hydrolysis to the monosaccharide. The enzymic method of hydrolysis has become of considerable importance industrially for the removal of pectic acid from fruit drinks and wines. Kenglein and Schneider (Ber. 1936, 69 [B], 309), demonstrated that pectic acid was a polymer of high molecular weight, their views being in contrast with earlier opinions which had favoured a cyclic structure containing only six sugar residues. These authors nitrated pectin and showed that the

resultant nitrated ester possessed all the properties of a linear polymer of high molecular weight. This is in agreement with X-ray studies made by K. Meyer and H. Mark, "Der Aufbau der hochmolekularen Naturstoffe," Leipzig, 1930, p. 216. The work of Levene and Kreider (J. Biol. Chem. 1937, 120, 591) indicated that in pectic acid (II) there exists a chain of (2-galacturonic acid residues in which the hydroxyl groups on C<sub>2</sub> and C<sub>3</sub> were free. This was proved by oxidation of pectic acid with periodic acid, followed by the isolation of d-tartaric acid\* (III) after hydrolysis and bromine oxidation of the resultant polymeric dialdehyde (IV). These results were confirmed by Smith (Chem. and Ind. 1939, 58, 364) and by Beavan and Jones (*ibid.* 363), who methylated degraded pectic acid from various sources and isolated 2:3 - dimethyl - d - galacturonic acid (V) after hydrolysis of the methylated materials (VI). These results indicate that part, if not all, of the pectic acid molecule consists of d-galacturonic acid residues (I) linked through the hydroxyl groups on C<sub>2</sub> and C<sub>3</sub> or C<sub>4</sub> and C<sub>5</sub> with the formation of a linear polymer. The extraordinary stability of pectic acid to acidic hydrolysis indicates that a pyranose ring structure is present in the sugar molecule and that

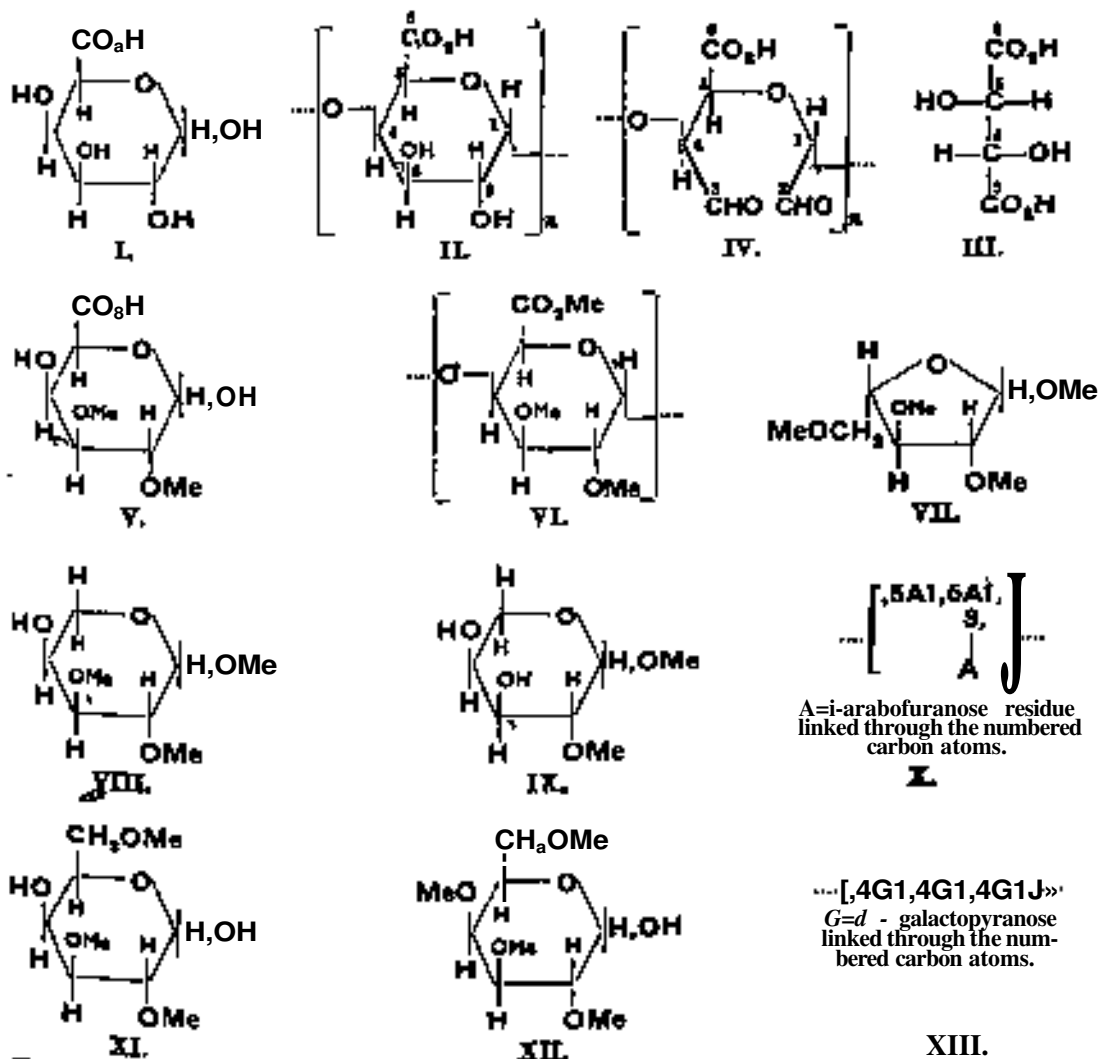

the linkage is through the hydroxyl groups on C<sub>x</sub> and C<sub>4</sub>.

Ehrlich, a pioneer in this field of carbohydrate chemistry, was the first to isolate a pure sample of *araban* from pectin and his method of separation (extraction with 70% alcohol) is still the best available in spite of its tedious nature. More recently this *araban* has been isolated from a variety of pectic materials including those present in the peanut, apple pomace, and in citrus fruit (Hirst and Jones, J.C.S. 1938, 408; 1939, 452, 454, 1865). It is characterized by a high negative rotation and by its ready hydrolysis with dilute acid. The isolation of a pure *araban* has so far only been achieved via the acetate, by which means traces of pectic acid and galactan can be removed by fractional precipitation. Methylation of the *araban* followed by methanolysis gives three main products: 2:3:5-trimethyl methyl-Z-arabinoside (VII), 2:3-dimethyl methyl-Z-arabinoside (VIII), and 2-methyl methyl-Z-arabinoside (IX). The isolation of these products taken in conjunction with the ease of hydrolysis indicates that in *araban* at least one-third, and most probably all, of the arabinose residues are in the furanose form and that *araban* (X) is not a linear polymer like pectic acid but is a branched polymer.

The galactan present in pectic materials has so far been isolated in a pure state from one source only, namely, from the seeds of the white lupin. It has been shown (*see* Hirst, *ibid.* 1942, 70) by the methylation method that it is a linear polymer of high molecular weight, since the methylated galactan gives on hydrolysis 2:3:6-trimethyl d-galactose (XI), together with traces of 2:3:4:6-tetramethyl d-galactose (XII). Since the galactan (XIII) has a very small rotation and is hydrolysed by acid with difficulty it is considered that the sugar residues in the polymer are in the pyranose form, united through β-glycosidic links, whereas pectic acid, which has a high positive rotation, probably contains α-glycosidic links. On this evidence it seems unlikely that pectic acid is a direct intermediate in the conversion of galactan into *araban* by a process of oxidation of the primary alcohol grouping on C<sub>6</sub> of the galactose units followed by decarboxylation of the resultant galacturonic acid residues.

Pectin, which is found in practically all living plant tissue, is prepared on the commercial scale either from citrus fruit residues or from the apple pomace remaining after the expression of apple juice. The pectin is extracted by pressure cooking with water and the aqueous filtrate containing pectin and impurities may then be vacuum-concentrated and the pectin precipitated with alcohol. An alternative method is to precipitate the pectin as its insoluble calcium salt, or as insoluble nickel or copper salt followed by removal of the metals with ion exchange resins. If pectin of low methoxyl content is required then de-esterification by means of acids, alkalis or pectin esterase may be employed. This type of pectin is useful when the formation of gel structures by reaction with calcium or other polyvalent ions is required.

Molecular weight determinations of pectins from apples, pears, plums, and citrus fruits

indicate that they are of the order of 25,000-100,000 and therefore contain from 140 to 570 uronic acid residues. (Sigurd Saver bom, "A Contribution to the Knowledge of the Acid Polyurpnides," Uppsala, 1945.)

The increasing industrial importance of pectin has stimulated research on the physical properties and chemical reactions of these materials. Methods are now available for the preparation of acylated derivatives of pectin and of nitropectin. Pectin is also available as a source of D-galacturonic acid, 5-keto-Z-galactonic acid, D-altronic acid, vitaxnin-C and (+)-tartaric acid. The latter compound is produced by atmospheric oxidation of galacturonic acid under carefully controlled conditions of pH. The mechanism of formation of gels of pectin in sucrose solution has also received considerable attention. For jelly formation, the optimum concentration of pectin is about 0.7%, of sucrose about 60%, and acidity pH 3. Pectic acid, however, will form gels at lower sugar concentrations.

Salts of pectin are now used as aids in spray drying, for paper coatings, as thickening agents in desserts, as latex thickeners, and as a substitute for agar in bacteriological media. In addition, pectic acid (prepared by the enzymatic de-esterification of pectin, followed by removal of pectinic acids) yields a product which gives solutions of high viscosity and of good film-forming properties.

E. L. H. and J. K. N. J.

.PEGANINE (v. Vol. VI, 186a).

PELARGONENIN, a flavylum salt obtained by the partial hydrolysis of natural pelargonin (*q.v.*) by means of cold, concentrated hydrochloric acid (Willstätter and Bolton, *Annalen*, 1917, 412, 133), crystallises from the warm 2% acid in the form of scarlet-red needles of the dihydrate, C<sub>21</sub>H<sub>21</sub>O<sub>10</sub>Cl<sub>2</sub>·2H<sub>2</sub>O. The salt is very sparingly soluble in cold water or dilute hydrochloric acid. At 18°, 100 c.c. of 0.5% acid dissolve only 2 mg. It is also sparingly soluble in cold 7% sulphuric acid, but it dissolves readily on warming. It is easily soluble in methyl alcoholic hydrogen chloride, and it dissolves more freely in ethyl alcohol than does pelargonin. Its solution in hydrochloric acid is yellowish-red, a solution of pelargonin, and yellower than one of pelargonidin in the same solvent. The most characteristic property of pelargonin is the strong greenish-yellow fluorescence of its alcoholic solutions, which is much more intense than that of pelargonin. Pelargonin chloride has been synthesised by Leon, Robertson, hobinson, and Seshadri (J.C.S. 1931, 133, 2672), who have shown that it is the 5-O-glucosido of pelargonidin chloride (I). Of the isomeric glucosides, all of which have been synthesised, none shows a fluorescence in alcoholic solution,

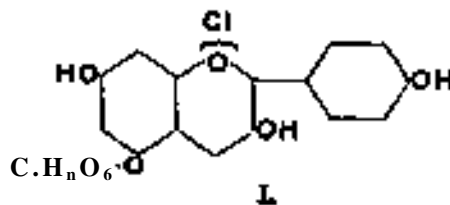

W. B.

PELARGONIDIN was obtained in the first instance by the hydrolysis of pelargonin (*q.v.*). Calliscephin, pelargonidin-3-glucoside, occurs in the flowers of the summer aster (*Callistephus chinensis*). Fragarin, the colouring matter of strawberries (*Fragaria vesca*), is the corresponding galactoside (Robinson, Ber. 1934, 67 [A],\* 98). Pelargonidin saccharides are very widely distributed in nature. Pelargonidin-3:5-dimonosides (pelargonin type) are present in *Gladiolus gandavensis*, *Hyacinthus orierdalis*, *Lathyrus*, *Pentstemon*, *Phlox*, *Clarkia elegans*, *Dianthus caryophyllus*, *Dahlia*, *Solarium tuberosum*, and *Zinnia*, and in a pure state in orange-red polyantha roses. Pelargonidin-3-biosides have not as yet been isolated from natural sources but there have been many indications of their occurrence in *Delphinium nudicaule splendens*, *Sophonitis grandiflora*, *Papaver nudicaule*, *Lathyrus odofibius*, *Anemone coronaria Campanula*, *Gladiolus gandavensis*, *Gloxinia*, *Cineraria steUata*, *Tropseplum majus*. *Tulipa gesneriana*, and in *Begonia semperflrens*; in *Phaseolus multiflorus* the 3-bioside is present in a pure condition. In some instances the biose residue is known to be that of a rhamnoglucoside [*Gloxinia a\*d Streptocarpus*], or a pentose-glycoside (*Solanum tuberosum*, *Lilium Vincifolium rubrum*, *Gfsnera zebrina discolor*. *Ilex sheperdii*, *Antirrhinum majus*, *Gotoneaster simmonde*, *Scabiosa*, and *Cydonia japonica*). The 3-monoside type occurs in *Verbena*, *Dianthus barbata*, *Lychnis chalconica*, and *Papaver orientate bracteatum*. Acylated saccharides of pelargonidin are present in the scarlet salvia and *Monarda didyma* (see *Monarda*ein), *Hyacinthus* and *Impatiens holsfii*. (See G. M. and R. Robinson, Biochem J. 1931, 25, 1693; 1932, 26, 1647; 1934, 28, 1712).

Pelargonidin chloride forms a monohydrate, C<sub>16</sub>H<sub>11</sub>O<sub>6</sub>Cl·H<sub>2</sub>O, which crystallises from hot 2% hydrochloric acid in short, red-brown, rectangular prisms,\* and from the dilute acid on adding an equal volume of concentrated acid in swallow-tail, twinned crystals, which are yellow-browns by transmitted light. The anhydrous

salt can be obtained only by heating the hydrate at 105° in high vacuum. The anhydrous chloride is brown in colour, but it retains the metallic lustre of the hydrate. It is very hygroscopic; exposed to air, the red monohydrate is soon regenerated. The chloride does not melt below 350°. Heating with dilute hydrochloric acid changes pelargonidin chloride into a more soluble derivative. It is sparingly soluble in cold, dilute hydrochloric acid, although much more readily than is cyanidin. The solution differs from that of most anthocyanidins in that an absorption band is present in the indigo blue—violet, in addition to one in the yellow—blue region. The aqueous acid solution is rendered blue on the addition of sodium carbonate. With ferric chloride there is no characteristic coloration; an alcoholic solution is merely rendered reddish-brown. The chloride is very easily soluble in methyl and in ethyl alcohol, forming red solutions which have a violet tinge and are non-fluorescent. A change of colour to violet occurs on the addition of sodium acetate. Lead acetate gives a blue precipitate. The chloride is very largely extracted from an aqueous acid solution by the "cyanidin reagent," and completely by the "delphinidin reagent." The former is a mixture of cyclohexanol (1 vol.) and toluene (5 vols.), the latter a 5% solution of picric acid in a mixture of amyl ethyl ether (1 vol.) and anisole (4 vols.). Heating to 220° with concentrated aqueous potassium hydroxide hydrolyses pelargonidin chloride to phloroglucinol and 4-hydroxybenzoic acid, with a small amount of protocatechuic acid (Willstatter and Bolton, Annalen, 1915, 408, 42). The structure (III) for the chloride, which was proposed by these authors, was confirmed by a synthesis (Willstatter and Zechmeister, Sitzungsber. Preuss. Akad. Wiss. Berlin, 1914, 886; Willstatter, Zechmeister, and Kindler, Ber. 1924, 57 [B], 1938) in which the trimethoxycoumarin (I) was condensed with p-methoxyphenylmagnesium bromide to form a salt (II), which was then demethylated to pelargonidin chloride (III).

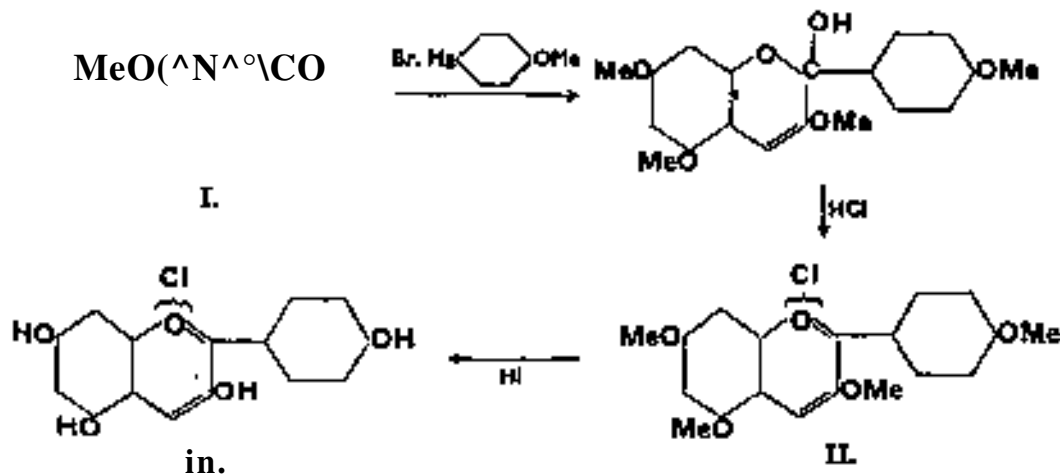

The same salt has also been prepared by condensing 2:4-dimethoxy-6-hydroxybenzaldehyde with co-4-dimethoxyacetophenone, and demethylating the product (Pratt and Robinson,

J.C.S. 1924, 125, 197), and again by the same authors (*ibid.* 1925, 127, 1182) using acetylated phloroglucinaldehyde in place of the dimethyl ether. A further synthesis with additional

practical merit consists in combining 2-O-benzoylphloroglucinaldehyde with  $\alpha$ -4-dihydroxyacetophenone, hydrolysing the intermediate acylated flavylum salt by means of alkali, and reconstituting the salt by further treatment with acid (Robertson, Robinson, and Sugiura, *ibid.* 1928, 1533).

*Pelargonidin*  $\beta$ -base,  $C_{25}H_{12}O_6$ , crystallises from water in the form of colourless, four-sided prisms, which redden on heating and gradually form a dark violet oil. It is formed when the chloride is heated with water, preferably with the addition of a small amount of sodium bicarbonate. It is insoluble in benzene, easily soluble in cold water, and very easily in alcohol and ether. It dissolves in aqueous sodium carbonate with a yellow colour. Addition of hydrochloric acid to an aqueous solution causes the regeneration of the chloride.

W. B.

PELARGONIN is the anthocyanin colouring matter of the scarlet geranium (*Pelargonium zonale*). Willstätter and Bolton (*Annalen*, 1915, 408, 42) extracted the dried petals with glacial acetic acid and precipitated the crude anthocyanin in the form of a red solid by adding alcoholic hydrogen chloride and then ether. A purer product could be obtained by extracting the petals with alcohol and adding the alcoholic acid and then ether to the filtered solution. The salt was purified by dissolving it in hot 2% methyl-alcoholic acid, filtering, and adding a quarter or a fifth of the volume of 10% aqueous hydrochloric acid. Pelargonin chloride crystallises in the form of fine, very slender, scarlet-red needles of the *tetrahydrate*,  $C_{27}H_{31}O_{15}Cl \cdot 4H_2O$  (dried in air), which when rubbed acquire a green metallic lustre. The anhydrous chloride,  $C_{87}H_{31}O_{15}Cl$ , results when the hydrate is exposed in a desiccator; it is darker in colour than the hydrate and is very hygroscopic. It sinters at  $175^\circ$ , and melts with decomposition at  $180^\circ$ . Kaner and Widner (*Helv. Chim. Acta*, 1929, 12, 292) give m.p.  $184^\circ$ , and  $[o]_D -236^\circ \pm 20^\circ$  and  $-241^\circ \pm 20^\circ$ .

Pelargonin chloride is fairly soluble in cold water, forming an orange-coloured solution. Hydrolysis occurs readily, the colour changing to violet and then fading (formation of the *pseudo-base*). It is fairly soluble in cold methyl alcohol, more readily on warming, forming yellowish-red solutions which show a greenish-yellow fluorescence. This property is characteristic of the anthocyanin. Even in 1-2% hydrochloric acid the chloride is sparingly soluble; in 5% acid it dissolves very sparingly. The solutions are, in orange-red in colour. The solubility in 7% sulphuric acid is very slight; from a warm solution the *sulphate* crystallises on cooling. The *nitrate* and *oxalate*, also, are sparingly soluble.

Ferric chloride gives no well-defined reaction with the chloride, the colour of a solution is merely rendered more reddish-brown. There is no reaction with alum. Sodium carbonate changes the colour of an aqueous solution to violet, which changes slowly through greenish-red to yellow. The reaction with sodium hydroxide is similar but the colour changes occur more rapidly. Sodium acetate, lead

acetate or calcium carbonate cause the precipitation of the violet *colour-base*. In alcohol the reactions are somewhat different; a drop of sodium hydroxide or potassium acetate solution gives a blue colour, which immediately changes to violet on the addition of water. Fehling's solution, even when warm, is only slightly reduced by the chloride.

*Basic pelargonin chloride*,

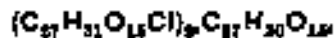

is formed when the normal chloride is boiled for a few minutes in alcoholic solution. A portion of the salt remains undissolved in the form of violet flocks, while from the cooled solution there crystallise small, dark-violet needles of the *dihydrate* of the *basic chloride*.

The *colour-base* is precipitated in the form of violet flocks,  $C_{27}H_{31}O_{15}$ , when sodium acetate is added to a weakly acidic solution of the chloride. It is difficultly soluble in water; in solution it is transformed into the colourless *pseudo-base*.

\* Hydrolysed by heating for a few minutes with 20% hydrochloric acid pelargonin yields pelargonidin<sup>+</sup> chloride (1 mol.) and glucose (2 mol.). R. Robinson deduced that the Anthocyanin is pelargonidin-3:5-diglucoside, and this constitution<sup>+</sup> has been confirmed by a synthesis (Robinson and Todd, *J.C.S.* 1932, 2488)\* 2-O-Monoacetyl-j9-glucosidylphloroglucinaldehyde (I) was condensed with co-0-tetra-acetyl-j8-glucosidoxy-4-acetoxyacetophenone (II), and the intermediate acylated flavylum salt was deacetylated to give *pelargonin* chloride (III).

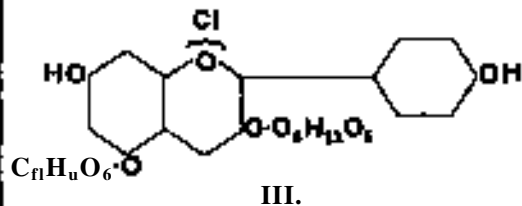
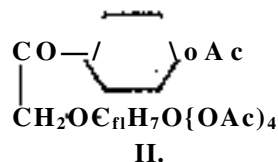
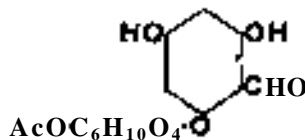

W. B.

PELLETIERINE. Used medicinally, the term "Pelletierine" means a mixture of alkaloids of pomegranate (*q.v.*) but chemically the term should be restricted to the pure alkaloid first mentioned by Tanret. Pelletierine and other alkaloids of pomegranate have been studied also by Ciamician and Silber (*Ber.* 1892, 25, 1601; *ibid.* 1893, 26, 156, 2738; 1894, 27, 2850); Piccini (*Gazzetta*, 1899, i, 29, 408; *ibid.* 29, 311) and by Willstätter and Veraguth (*Ber.* 1905, 88, 1984). According to Hess (*ibid.* 1917, 50, 368; 1919, 52, 964, 1000, 1622; Hess and

Eichel, *ibid.*, pp. 380, 1192, 1386; 1918, 51, 741) no optically active alkaloid occurs in the bark, but Faiyet reaffirms (Compt. rend. 1920, 170, 1118) pelletierine and methyl pelletierine to be active, the former  $[\alpha]_D^{20} -31.1^\circ$ , the latter  $[\alpha]_D^{20} 4.27.7^\circ$ , both being easily racemised. *iso*-Pelletierine and *wemethyl*pelletierine are the corresponding racemic compounds. Pelletierine has been synthesised by Wibaut and Beets (Bev. trav. chim. 1940, 59, 653) by the following process: *picoline*  $\xrightarrow{\text{C}_6\text{H}_5\text{Li}}$  *picolyl-lithium*  $\xrightarrow{\text{Bromoacetal}}$  *3-(2-pyridyl)-propionaldehyde acetal*, which was isolated as the mercuric chloride addition complex. The synthesis is completed by reduction of the pyridine ring by hydrogenation, using platinum in glacial acetic acid (Wibaut and Beets, *ibid.* 1941, 60, 905; see also Sjielman, Swadesh, and Mprtenson, J. Org. Chem. 1941, 6, 780). The pelletierine acetal was identical with the acetal obtained from the natural product. Beets (Chem. Weekblad. 1942, 39, 187; Chem. Zentr. 1942, n, 776) further studied the reactions of lithium picolyl with acid esters and anhydrides; with acetic anhydride *dehydrojopelletierine* is formed. Beets also suggests that pelletierine is better represented as a dicyclic structure related to *coniceine* but the evidence is not conclusive.

*Pelletierine*,  $\text{C}_8\text{H}_{16}\text{NO}$ , is a colourless liquid boiling at  $195^\circ\text{C}$ . with decomposition ( $106^\circ/21\text{ mm.}$ );  $p 0.988$ ; soluble in 23 parts of water at  $15^\circ$ , giving a strongly alkaline solution. It forms an oxime and a hydrazone; reduction of the latter with sodium and alcohol forms coniine,  $[\alpha]_D^{20} -31.1^\circ$ . The *hydrochloride*, m.p.  $143-144^\circ$ , is not hygroscopic; the *hydrobromide* melts at  $147^\circ\text{C}$ .

*iso*Pelletierine, the racemate of pelletierine, has been resolved by Hess and Eichel through the tartrate.

*4-Pelletierine*,  $\text{C}_9\text{H}_{15}\text{ON}, 2\text{H}_2\text{O}$ , is related to the solanaceous alkaloids and has been synthesised by Menzies and Robinson (J.C.S. 1924, 125, 2163) from calcium acetopropionic acid, glutaraldehyde and methylamine. Tanret (J. Pharm. Chim. 1928\* [viii], 8, 112) has defined the optimum conditions for the preparation of pure *iso*-pelletierine salts and the analysis of commercial samples.

*iso*-Pelletierine is the only solid alkaloid of pomegranate and has m.p.  $53-54^\circ\text{C}$ ., b.p.  $140^\circ/20\text{ mm.}$ ,  $246/760\text{ mm.}$

The structures of the pomegranate alkaloids given below show their close relationship to one another and to coniine and coniceine.

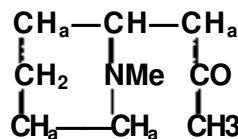
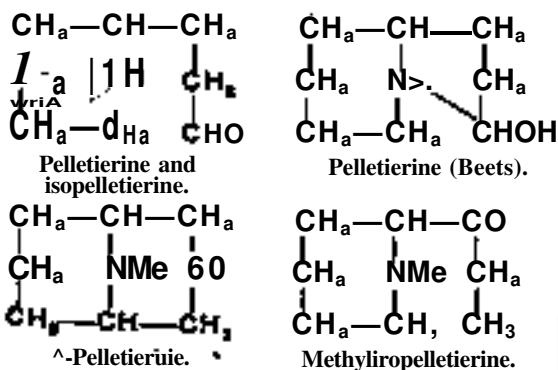

*iso*-Methylpiperidylpropane.

W. H. L.

PELTOGYNIDIN is a distinct anthocyanidin which is obtained by the action of hot aqueous hydrochloric acid on the "leucoanthocyanin," peltogynol (*q.v.*) (G. M. and B. Robinson, Biochem. J. 1933, 27, 210), isolated from the heartwood of *Peltogyne pubescens* and *P. porphyrocardia*. It forms oxonium salts which dissolve in water with a cyanidin-like bluish-red colour, characterised by unusual brightness.

Its aqueous solution gives a pure blue colour with sodium carbonate, and its solution in amyl alcohol a red-violet which is redder than the corresponding coloration with cyanidin. In its stability towards oxidation by means of aqueous ferric chloride it resembles cyanidin. Its solution in concentrated sulphuric acid shows a green fluorescence as does that of fisetinidin (I), but the colour of the solution is pink; in this peltogynidin differs from (I) and resembles cyanidin. Its distribution from an aqueous acid solution to the delphinidin reagent (a 5% solution of picric acid in a mixture of amyl ethyl ether, 1 vol., and anisole, 4 vols.) is very high (100), whilst to the cyanidin reagent (a mixture of cyclohexanol 1 vol., and toluene, 5 vols.) the distribution is low (<5). Ethyl acetate extracts it from a solution containing salt. In these properties peltogynidin closely resembles 5-O-methylcyanidin (II). The only other structural type to which peltogynidin might belong is that of a 7-O-substituted cyanidin (III). Peltogynidin is not completely extracted from 1% hydrochloric acid by means of amyl alcohol (difference from II), and it may be re-extracted from the alcohol by repeated washing with 1% acid. Possibly one or more hydroxyl groups are present in the O-substituent. The most

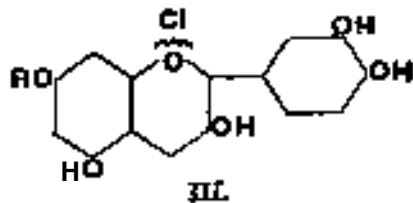
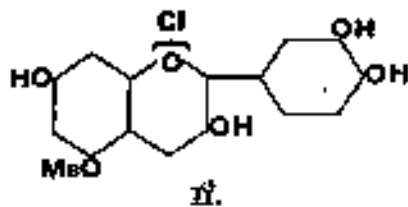
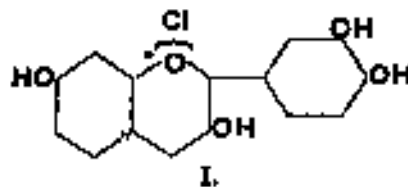

characteristic reaction of peltogynidin is the change of colour of an alcoholic solution through blue to bright red with sodium hydroxide. No other anthocyanidin exhibits this property.

W. B.

**PELTOGYNOL.** The heartwood of *Peltogyne porphyrocardia*, *P. pubescens*, and *Copaifera pubiflora* is light brown in colour when freshly cut, and deep purplish-red after exposure to light and air. The colouring principle, peltogynol, is extracted by water from the fresh sawdust, isolated in the form of a light mauve powder by adding sodium chloride and bicarbonate, extracting by means of ethyl acetate and precipitating from the extract by adding light petroleum. Peltogynol,  $C_{16}H_{14}O_6$ , crystallises from ethyl acetate in colourless, elongated, flat prisms, which on heating become pink at  $200^\circ$  and darker red at about  $240^\circ$  with gradual softening and decomposition. It is sparingly soluble in cold water and fairly readily in hot, very sparingly soluble in ether, benzene, and chloroform, readily in acetone and freely in the simple alcohols. The crystals which separate from ethyl acetate become syrupy in contact with water, but recrystallisation occurs in a new form. Ferric chloride added to an aqueous or alcoholic solution gives a bright green colour. Pure peltogynol,  $[\alpha]_D^{25} +273^\circ$  ( $c=0.6$  in ethyl acetate), is stable in light and air.

Peltogynol readily gives a *tetra-acetyl* derivative, which crystallises from benzene—alcohol in colourless, flat rectangular, prismatic needles, or in hair-fine needles, m.p.  $173^\circ$ ,  $[\alpha]_D^{25} +125^\circ$  ( $c=0.4$  in chloroform). This derivative shows quite different properties from peltogynol, for, whereas the latter readily forms the anthocyanidin, peltogynidin, with hydrochloric acid, the acetyl derivative cannot be converted directly into this salt even when it is treated with bromine in dioxan. Alcoholic acid causes gradual hydrolysis and subsequent formation of the anthocyanidin. The *O-teirabenzoyl* derivative forms colourless plates from acetic acid, m.p.  $244^\circ$ . The *O-tetra-anisoyl* derivative has m.p.  $218^\circ$  (decomp.).

A *tri-* and a *tetra-methyl ether* of peltogynol have been prepared by direct methylation with methyl sulphate and sodium hydroxide. The trimethyl ether is also formed when the tetramethyl ether is hydrolysed by means of a cold solution of hydrogen chloride in dilute acetic acid.

Peltogynol tetramethyl ether forms colourless, glistening, long rectangular plates, m.p.  $175^\circ$ ,  $[\alpha]_D^{25} +264^\circ$  ( $c=0.73$  in chloroform). It is moderately soluble in most organic solvents, hot aqueous or cold alcoholic hydrochloric acid, or bromine in dioxan, convert it into a trimethylpeltogynidin salt possessing a brilliant green fluorescence, and which doubtless contains the ring system of (I).

Peltogynol trimethyl ether forms long, flat, colourless needles or plates from ethyl acetate, m.p.  $198^\circ$ ,  $[\alpha]_D^{25} +254^\circ$  ( $c=0.23$  in chloroform). It is sparingly soluble in cold benzene (difference from the tetramethyl ether). It gives the same trimethylpeltogynidin salt as the tetramethyl

ether. It is insoluble in aqueous alkalis and gives no ferric chloride reaction in alcoholic solution, evidence that the fourth methyl group of the tetramethyl ether must be present in a semi-acetal structure of the methylglucoside type. The tetramethylether does not contain a carbonyl group (absence of a reaction with a Grignard reagent).

Peltogynol itself affords a *2-A-dinitrophenyl-hydrazone*, an orange, microcrystalline powder consisting of dense aggregates of needles, which darkens at  $190^\circ$ , becomes chocolate-brown at  $220^\circ$ , and explodes at  $224^\circ$ . The characteristic crimson peltogynidin chloride is formed when the hydrazone is boiled with concentrated hydrochloric acid.

Oxidation of peltogynol by means of nitric acid affords styphnic acid. The trimethyl ether with potassium permanganate yields *O-tri-methylpeltogynic acid*\*,  $C_{19}H_{18}O_7$ , considered to be a mixture of the two tautomeric forms (II) and (III), and m-hemipinic acid.

The above-mentioned facts and the alkali colour-reactions of peltogynidin salts strongly support the constitution (I) for peltogynol, which, moreover, is compatible with the evidence of X-ray measurements. It is a plausible suggestion that in the leucoanthocyanins the hydroxyl group indicated by an asterisk is etherified by a sugar unit (G. M. and B. Robinson, J.C.S. 1935, 744).

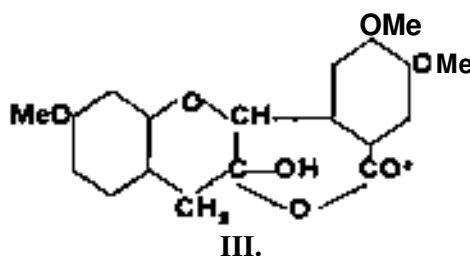
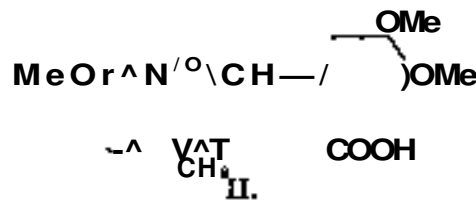
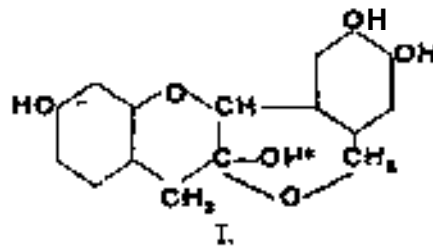

W. B.

## PENICILLIN.

### History.

In 1929 Fleming (Brit. J. exp. Path. 1929, 10, 226) observed that an agar plate culture of staphylococci showed lysis of the bacteria around an air-borne mould accidentally contaminating the culture. The contaminant was subsequently identified as *Penicillium notatum* Westling. The mould was sub-cultured in

peptone broth and the filtered medium, even when diluted 800 times, was found to inhibit the growth of certain bacteria. The name "penicillin" was used by Fleming for the filtered liquid which was found to have a particularly strong antibacterial action on pyogenic cocci, although harmless to leucocytes and not more toxic than the original broth to experimental animals. A few preliminary experiments in which the medium was used as a wound dressing suggested that it might be of clinical value as an antiseptic but the only immediate practical outcome of this work was Fleming's use of "penicillin" in bacteriological work as an aid to the isolation of penicillin-insensitive organisms.

Some three years later Clutterbuck, Lovell, and Raistrick (Biochem. J. 1932, 26, 1907) published the results of attempts to concentrate or isolate the active substance, in Fleming's liquid "penicillin." Valuable advances were made towards the development of satisfactory extraction procedures, particularly as applied to synthetic culture media containing only inorganic salts and dextrose. Medical interest could not be secured, perhaps because the sulphamide group of drugs was then becoming prominent, and eight years elapsed before previous work was brought to full fruition by a team which included workers in clinical medicine as well as those in ancillary fields. This team working under Professor Florey at Oxford, published its first report in the Summer of 1940 (Chain, Florey, Gardner, Heatley, Jennings, Orr-Ewing, and Sanders, Lancet, 1940, 2, 177). A relatively rapid assay process, developed by Heatley (*v. infra*), had enabled them to ascertain the conditions under which the active substance could be extracted and preserved for appreciable periods. The antibacterial activity of their final product against staphylococci was of the same order as that of previously known antiseptics. It was therefore thought that the product they had tested on experimental animals was nearly pure although, in fact, it contained only about 1% of pure penicillin. This first paper of the Oxford workers reported exceedingly successful results in experimental infections due to streptococci, staphylococci, and *Clostridium septique*, a factor of the greatest importance being the complete absence of toxicity. The quantity of penicillin required was minute on the basis of weight. Nevertheless the low titres of the culture medium and the difficulties of extraction necessitated several months of work before sufficient had accumulated for the treatment of the first human case (Abraham, Chain, Fletcher, Florey, Gardner, Heatley, and Jennings, *ibid.* 1941, 2, 177). The product was not entirely free from toxicity, nevertheless the patient's response was dramatic, but unfortunately the amount of penicillin available was too small to complete the cure. It was soon found that the impurities responsible for the reaction produced in the first human case to be given penicillin parenterally could be removed by chromatography. In addition, larger supplies of the drug became available when a firm of manufacturing chemists having experience in the fermentation field provided the Oxford workers with the culture medium from

which they could extract the penicillin. Sufficient to show its value in a variety of septic infections was thus made available and the need for large-scale commercial manufacture became acute. War conditions in Great Britain made it difficult, in the absence of active governmental assistance, for manufacturers to enter a new field on the scale necessary to produce a significant amount of the new drug. Florey and Heatley therefore visited U.S.A. with a view to stimulating American interest, and, with the encouragement of the Committee on Medical Research of the Office of Scientific Research and Development, five American manufacturing chemists began the commercial development of penicillin on the basis of the information given them. Investigations were also begun by the workers in the Fermentation Division of the Northern Regional Research Laboratory of the U.S. Department of Agriculture.

Meanwhile various British manufacturers co-operated in joint investigations, with such limited resources as could be spared from more immediate wartime demands. Reports of clinical trials from America and the use of American material by the British Services led to recognition by the British government that manufacture in the United Kingdom was highly desirable, and thereafter manufacturers received full official support. The first British penicillin factory was opened in February, 1943, to operate the surface culture process [*v. infra*].

#### MANUFACTURE.

The commercial process for the manufacture of penicillin is a relatively simple one. In brief, a strain of a mould of the *Penicillium notatum-chrysogenum* series is grown in pure culture on or in a nutrient medium, and when maximum growth has been obtained the medium is separated from the mould, which is then discarded from the process. A substantial part of the penicillin produced during the growth of the mould is contained in the medium, from which it is then extracted, purified, and concentrated. The concentrate, containing varying proportions of penicillin and impurities derived from the medium, may then be freeze-dried to produce a reasonably stable solid ready for use or, in more advanced processes, crystalline penicillin may be obtained by repeated crystallisations, from the purified concentrate. The process is divided into three readily separable phases:

1. Fermentation, or growth of the mould;
2. Extraction and concentration, - or the recovery of penicillin from the medium;
3. Freeze-drying of, or crystallisation from, the concentrate.

In addition, a fourth major activity comprises the "biological control of the product, which is effected at all stages of its manufacture.

#### Fermentation.

It is now clear that a number of moulds, generally referred to as of the *Penicillium notatum-chrysogenum* series, together with other distinct penicillia, produce penicillin during



their growth processes. The importance of the strain employed in the fermentation cannot be over-emphasised, for it determines the order of yield of penicillin as well as the variety of penicillin produced. Initially, the original Fleming strain was employed but it was soon displaced by a high-yielding derivative designated NBRL 1249.B21. The use of this strain in surface culture techniques became nearly universal but, with a change to the submerged culture procedure, a new strain adapted to this technique came into common use. This is known AS NRRL 832 and, as with the former surface culture strain, was issued from the culture collection of the Northern Regional Research Laboratory, Peoria, Illinois. With the extension of the submerged culture technique, a large number of different strains were isolated and reported as being of commercial value; some of them were chosen for the production of specific penicillins rather than for considerations of increased general yield of penicillin. The next major advance in strain selection occurred with the demonstration that it was possible to derive strains, by exposure to X-ray and ultra-violet irradiation, which were substantially different in point of yield from the strains isolated from naturally occurring moulds. The principal strains in this connection were the Demerec X1612 and the Wisconsin Q176; the latter, which is a selection from ultra-violet-irradiated spores of *P. chrysogenum*, is so far the highest-yielding strain. With the development of these high-yielding strains especial attention must be given to the preservation of their original characteristics by reducing to a minimum the number of "generations" raised from spores. It has been found that continued sub-cultivation through spores results in a substantial drop in the penicillin yield obtained—a phenomenon referred to as "penicillin run-down"—and vegetative transfers are recommended.

Members of the genus *Penicillium* are exceedingly widespread in nature, being remarkably polyphagous and strongly aerobic. The penicillin-producing moulds grow readily as aerobes on common nutrient media, either solid or liquid, but, for the convenience of the subsequent extraction of penicillin, liquid media are preferred. Many different formulae for liquid media have been described, some of them adaptations of conventional bacteriological substrates and simple synthetic media formerly employed in metabolic studies.

A major improvement in medium development occurred with the discovery attributed to Moyer that the addition of corn steep liquor to the medium increased the yield of penicillin five-fold (B.P. Application no. 1367 of 1946 claiming the Convention date, 8th April, 1944, but see Foster and McDaniel's application no. 9297 of 1944 claiming 16th May, 1943). Corn Oteep liquor is primarily an extract of maize solubles under acid conditions and has come to occupy an essential place in the manufacture of penicillin because of its availability and price, but extracts of many other vegetable products have been used, a very effective one being obtained from peas. Apart from the high contribution of protein and amino acids by corn steep liquor or

pea extract, a substantial addition of carbohydrate is necessary. Glucose, sucrose, and lactose have all been employed, but lactose, by virtue of its stabilising effect upon the yield of penicillin, is most frequently used. The addition in various concentrations, of inorganic salts to the medium has been recommended but, with the use of a crude extract such as corn steep liquor, these requirements are now of less importance, with the possible exception of nitrate. The regulation of the pH of the medium is of first importance, and a range from 5.5 at the beginning of fermentation to 7.5 at the end is recommended for maximum production.

The discovery originating from the Northern Regional Research Laboratory that the addition of small quantities of phenylacetic acid to the medium stimulated penicillin yields has been followed by trials of a series of related aromatic compounds. Later but independent British work (Lester Smith, J.S.O.I. 1946, 65, 308) showed that similar results followed the use of a number of compounds carrying the benzyl group, notably phenylacetamide and *β*-phenylethylamine. Generally, amide derivatives have been as satisfactory as the corresponding acids and a number of compounds of this type, are referred to in B.P. Applications nos. 20987, 21830, 22087, 22144 of 1946. The use for the same purpose of phenylacetyl hydrolysates of various proteins is described in Application no. 20799 of 1946. The growth of the mould proceeds satisfactorily at temperatures from 20° to 27°c. but highest yields of penicillin are obtained in surface culture at 24°c. Elaborate air-conditioning systems have been needed in surface culture plants to maintain this temperature throughout the duration of incubation despite the considerable amount of heat evolved during fermentation.

### Surface Culture.

It was natural that the commercial production of penicillin should, in the first instance, follow closely the laboratory technique. This original method—now referred to as "surface culture"—consisted of sowing the mould spores of a suitable penicillin-producing strain upon the surface of a shallow layer of medium held in a closed flask. Since penicillin is readily destroyed by enzymes—referred to as "penicillinase"—produced by many common bacteria, the paramount requirement is that of maintaining a pure culture. To this end the flask with its content of medium is closed with a plug of cotton or glass-wool permitting gas exchange while preventing the ingress of micro-organisms; the whole is then sterilised by autoclaving. A sterile transfer of mould spores is made to the surface of the liquid medium and the culture incubated for a period of 7-14 days. After 2 days the surface of the medium is covered with a thin white growth which thickens rapidly to form in 3-4 days a tough white felt. Thereafter sporulation takes place, the upper surface of the white felt turning bluish-green and the under-side becoming pallid or yellowish. Droplets of a solution of the yellowish pigment chrysogenin frequently appear on the surface of the felt and contain appreciable quantities of penicillin. When the surface of the

felt becomes a dull smoky-grey colour the culture has attained its maximum growth and usually exhibits the greatest penicillin titre. On occasion the felt may remain white for longer than is usual, this effect being due principally to restricted aeration resulting from the cotton-wool plug becoming Vet or to an abnormally high incubation temperature.

In this surface-culture technique a large variety of glass containers have been employed, ranging from the conventional milk bottle to flasks especially designed for ease of stacking. Shallow depths of medium not exceeding 2 cm. have yielded in commercial practice as much as 300 i.u. per ml. of penicillin, but considerations of yield per flask per day frequently influenced the depth of medium commercially employed. The surface-culture technique was not confined to glass bottles. Manufacturers have employed large metal trays held in sterile cabinets or rooms but, on the whole, this method has presented

more difficulties than the simple flask, particularly in obtaining an adequate covering of the surface of the medium with mycelium and also in maintaining sterility. The inclusion of cork and other material has been suggested among a variety of ways of ensuring the flotation of the spores and consequent uniform covering.

Attempts have been made commercially to modify the tray method of growing the mould to a semi-continuous process whereby the medium held in the trays is continuously removed and replaced by fresh nutrients. A further modification adopted for semi-continuous operation consisted of growing the mould on liquid medium held in long horizontal pipes; once the felt has been established, fresh medium is introduced at one end of the pipe and spent nutrient containing penicillin withdrawn from the other. In this semi-continuous method, as in the previous one, it is necessary to maintain a sterile air supply

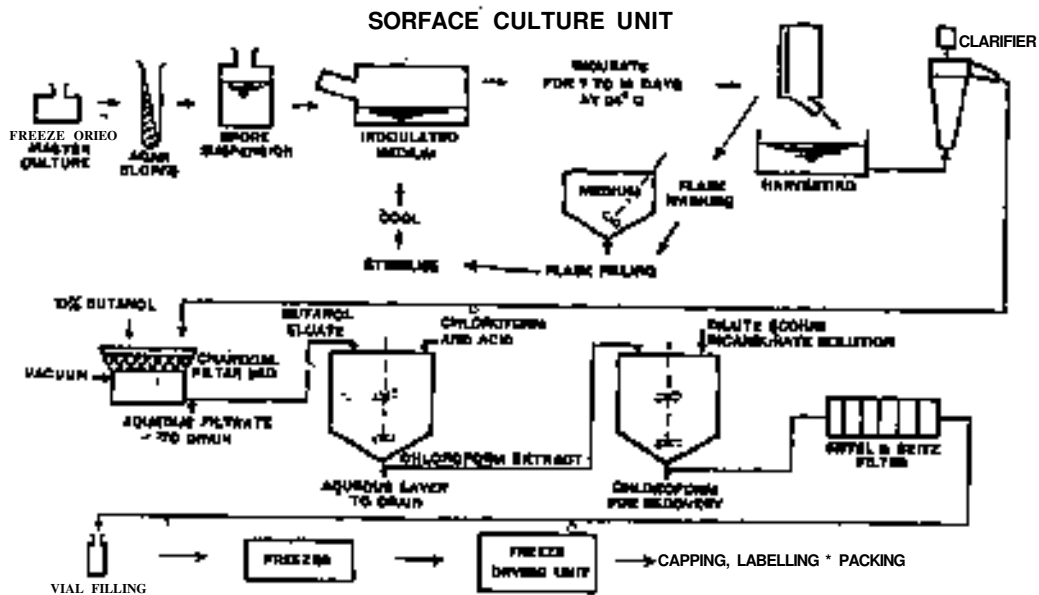

FIG. 1.

within the pipe or the chamber and this has been a source of recurrent difficulty from infections. A further semi-continuous method, not dependent on the flotation of the mould on a liquid nutrient, has been attempted using adaptations of the "quick" vinegar process, but in all such systems the hazard of infection has prevented their practical exploitation. The ability of the mould to develop satisfactorily and produce penicillin on a solid substrate has been proved to grow *P. notatum* on moist bran held in Biallow trays or in a slowly-rotating drum. Serious difficulties were encountered in sterilisation of the bran, largely because of its poor heat conductivity; difficulties were also encountered in the extraction of the penicillin after completion of fermentation. In such a process very large amounts of heat are evolved during the fermentation and make it exceedingly difficult to maintain the optimum temperature of incubation, *s.e.*, 24°o.

**Submerged Culture.**

The surface culture technique with flasks attained considerable commercial importance in the early stages of penicillin production. It was apparent, however, that advantages must accrue if the mould was grown submerged in the culture medium rather than as a surface mat relying upon supply of nutrients by diffusion from the liquor below. This change from surface to submerged culture is essentially only a change in the manner of aeration. The mould in surface culture is dependent for its supply of oxygen upon the passage of air through the microbial filter represented by the cotton-wool plug of the flask or bottle, while in submerged culture mechanical aeration ensures an adequate distribution of sterile air through the body of the medium.

The submerged culture technique necessitated major developments in chemical engineering. In the early stages many difficulties were encountered, but the technique has now become so

established that surface culture is wholly superseded.

In wartime England the development of submerged culture was restricted, but it was enthusiastically taken up in the U.S.A. The effect of its introduction in 1944, together with the derivation of new high-yielding strains of the mould, is shown in the penicillin production figures of that country in the following years:

1943 . . .	21,000 million units.
1944 . . .	1,633,000 "
1945 . . .	7,052,000 "
1946 . . .	25,000,000 " (estimated)

The advantages of the submerged method over the surface culture technique are apparent from a comparison of the unit culture. In the surface culture method the unit is a glass container holding about 200 ml. of medium and requiring incubation for 7-14 days while, with the submerged process, the unit container is a huge vat

often of 10,000 gallons capacity and the incubation period is 2-3 days. With the change in the manner of cultivation of the mould, from the surface mat to the submerged filaments, a substantial reduction in the concentration of the main nutrients followed, thus introducing an important economy and facilitating subsequent purification. It was early discovered that the surface culture strains were unsuitable for use with the new process but strains suited to the changed technique were soon introduced. Whereas the highest-yielding surface strains gave titres of 200-300 i.u. per ml. the new submerged strains very quickly exceeded this figure and, with the use of Q176 strain, penicillin yields of as much as 800-1,000 i.u. per ml. have been reported.

The principal problem in submerged culture, apart from the suitability of the strain\*, for this type of cultivation and the formulation of the medium, is the mechanical problem of supplying the giant fermentation vats with large volumes

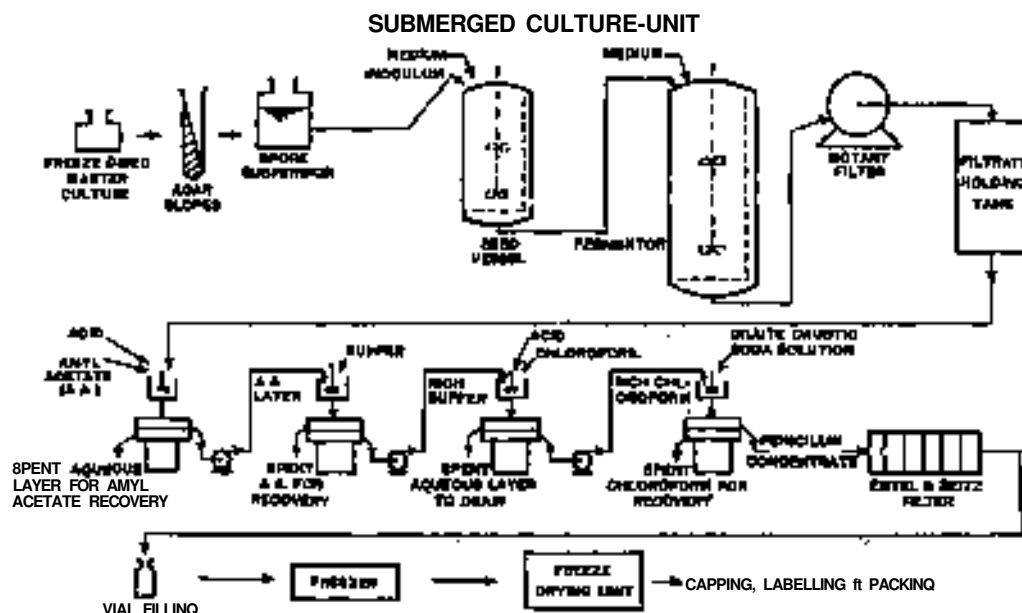

FIG. 2.

of sterile air. Sterility is essential since if penicillinase-producing organisms (*see below*) gain access the conditions in the vat are favourable to their growth and the penicillin is destroyed as rapidly as it is produced. The distribution of the sterile air within the vat may be achieved by systems comparable with those employed in commercial yeast manufacture and sometimes by employing additional mechanical agitation of the liquid medium to bring about the better admixture of the air with the medium.

With the change in the size of the unit container from a flask to a submerged culture vat, the same scrupulous attention must be paid to the pure culture status. Clearly, with the increase in size and reduction in number of fermentation units, the loss from a casual infection is enormously increased. However, the vast increase in penicillin production which has followed the adoption of the submerged culture technique is sufficient indication that any losses

due to infection are more than offset by the increase in throughput.

The mycelium as produced by submerged culture appears as fine threads suspended in the liquid medium, in contrast to the mat of mycelium produced in surface culture. The growth of these fine threads (or hyphae) may be so prolific as to give the liquid medium a thick pudding-like consistency. The method of separating the mould from the liquid medium containing the penicillin which, with the surface technique, was a simple matter of decanting the medium from below the tough substantial mat, has been replaced by mechanical methods of separation employing filter presses or vacuum rotary filters.

#### Extraction

Nearly all the extraction methods proposed or in use depend on two properties discovered very early in the history of penicillin, namely

the solubility of free penicillin acid in certain organic solvents and the adsorption of sodium penicillin on activated charcoal. Raistrick's team (Clutterbuck *et al.*, *I.e.*) showed that penicillin could be extracted from an acidified metabolism solution with ether but found that inactivation occurred on attempting to remove the ether. It was not until 1938 that Florey and fellow-workers found it possible to recover the activity in aqueous solution by shaking the ethereal layer with dilute alkali, and this fundamental property has been utilised in one stage or another of every commercial process. »

Initially, extraction methods were based upon the adsorption of penicillin by activated charcoal and its subsequent elution with aqueous acetone, alcohol, ether or ethyl acetate. With the early synthetic media it was found possible to adsorb the activity on 0.5% w/v of charcoal and to recover it completely by elution with one-twentieth volume of 20% acetone. On the introduction to the medium of corn steep liquor, however, the amount of charcoal had to be increased to at least 1.5% w/v and the eluate volume to 40% of the medium volume; this increase was due to the impurities present in the corn steep liquor and not a result of the increased penicillin content of the medium. While it was not possible to obtain a more active adsorbent, several more active eluents were found, notably saturated aqueous solutions of *n*-butanol, ethyl acetoacetate, and benzyl alcohol. The methods of employing charcoal varied from simple admixture by stirring to the use of "Metafilters" with a chromatographic technique. Thereafter, solvent extraction by one or more partitions into and out of chloroform resulted in a product with a potency of 5001,000 i.u. per mg.

While the above process was satisfactory for the small surface culture plants, for the larger submerged culture plants a return was made to the direct solvent-extraction of penicillin from acidified metabolism solution. In this process the clear medium is stirred with a suitable solvent together with sufficient phosphoric acid to reduce the pH to 2.0 and the mixture allowed to separate either by gravity or in centrifugal separators. Much trouble is caused in this step by a slight precipitate of protein which stabilises the emulsion and makes separation difficult, even in a centrifuge. The addition of surface-active agents to the mixture greatly improves the separation by preventing the formation of the protein precipitate; suitable agents are mentioned in B.P. Application nos. 6325 and 19546 of 1945. The solvent layer is next extracted with dilute sodium bicarbonate solution with a slightly alkaline phosphate buffer solution, thus giving an aqueous solution of penicillin at a concentration 20-50 times that of the harvested medium. This partition into and out of a solvent is repeated to give further concentration and purification; although amyl acetate is occasionally used for the second partition, a solvent of a different type is more usual. The combined effect of all these operations is to yield an aqueous solution of penicillin which is 100,000 times the medium concentration and is frequently of a potency greater than 1,400 i.u. per mg. of total dissolved solids.

### Freeze-drying.

The decomposition of penicillin salts in solution is markedly accelerated by a rise in temperature (*see below*), and accordingly the drying of the penicillin concentrate from the extraction process must be carried through at low temperatures, usually by the method of "freeze-drying." This consists of exposing a frozen solution to a high vacuum, whereby the ice sublimates without the intervention of a liquid phase and leaves the solids behind in an open-lattice form corresponding in volume to that of the original solution filled into the vial. Prior to the freeze-drying processes, the penicillin concentrate is first passed through an Ertel filter which provides coarse filtration and is claimed to remove pyrogens. Passage through a Seitz filter follows, rendering the concentrate sterile. Thereafter it is filled into vials under sterile conditions and removed to the freeze-drying plant. In the vacuum chambers of this unit, the frozen concentrate is held at a very low temperature, approaching  $-50^{\circ}\text{C}$ ., and a high vacuum is applied. In order to provide the latent heat of evaporation of the ice, heat is supplied to the vials by electric heaters or by circulation of a warm fluid, but in no event is the temperature allowed to rise above  $-20^{\circ}\text{C}$ . until all the ice is sublimed. Thereafter higher temperatures may be permitted, to bring about more complete removal of the last traces of residual moisture. In place of freeze-drying, heat from radio-frequency waves has been used (B.P. Application no. 24972 of 1945) and it has been claimed that this electronic method is extremely economical and rapid. The vials of dried penicillin are closed with a rubber stopper, secured by an aluminium seal and dustcap and are then ready, after packing, for distribution.

### Crystallisation.

With the increasing availability of supplies of penicillin, manufacturers have made available crystalline products. Crystalline penicillin may be prepared as a mixture of penicillins or as a relatively pure crystalline penicillin G containing not less than 90% of penicillin G. This latter product has a potency in excess of 1,600 i.u. per mg. and is pure white in colour.

There are three general methods for the preparation of crystalline penicillin, the simplest one being direct crystallisation of the freeze-dried salt from a suitable organic solvent, for example, acetone. In the other processes, an intermediate salt of an organic base with penicillin is formed either by adding a water soluble salt of the base to a strong solution of penicillin in water, whereupon the penicillin salt crystallises, or by adding a solution of the free base to a solution of penicillin acid in a suitable organic solvent. In these two methods, the conversion of the base salt of penicillin to sodium salt is effected by extraction of the purified penicillin into a solvent at pH 2.0 followed by extraction into water with the addition of sodium hydroxide to pH 7.0 exactly. There results a solution of purified sodium penicillin which can then be freeze-dried and subsequently crystallised from a suitable organic solvent.

*References.*

The details of procedures adopted in penicillin manufacture are still largely commercial secrets, but from time to time publication has been made of simplified flow-sheets for the process. Flow-sheets illustrating both the surface culture and the deep fermentation techniques are given in Figs. 1 and 2. In addition, numerous technical papers concerned with the biology of the mould, the applied chemistry of penicillin, and the working details of the biological assay are available and these together provide a background of fundamental knowledge upon which the process is built. An excellent introduction to the voluminous literature may be found in the following:

1. Anon., "Penicillin: Its properties, Uses, and Preparations," Pharmaceutical Press, 1946.
2. Holtman, "Antibiotic Products of Fungi," Botanical Review, 1947, 18, 59.

The patent literature is not yet extensive, mainly because patent applications relating to penicillin were the subject of secrecy orders during the war of 1939-45. In Britain the specifications filed with applications made under the International Convention are becoming open to public inspection and references to a number of these are given above. The number of applications in the penicillin field that have been accepted in the United Kingdom up to June, 1947, is relatively small.

## PROPERTIES.

Not only is "penicillin" a term covering a number of related substances that may be present singly or mixed but the substances or mixtures may vary widely in their freedom from non-penicillin impurities. Circumspection is therefore necessary in accepting statements of, for example, stability under various conditions for these may be true only of the particular penicillin, or mixture of penicillins and impurities, used in the investigation in question.

Penicillin is manufactured in the form of an alkali or alkaline earth metal salt, usually as the sodium, potassium, or calcium salt. Sodium penicillin is most commonly available as an amorphous yellow solid which is extremely hygroscopic. It may contain as much as 60% impurities but most of the yellow material available in Great Britain contains only about 30% impurities. Calcium penicillin, also yellow and amorphous, is much less hygroscopic than the sodium salt being therefore more easily handled if it is preferred for use in the manufacture of pharmaceutical preparations containing penicillin. It is usually of about the same purity as yellow sodium salt. The potassium salt resembles the sodium salt. Crystalline sodium penicillin occurs as relatively stable acicular crystals. When mounted in mineral oil and examined by means of a polarising microscope it shows resolvable particles which reveal the phenomena of birefringence (interference colours) and extinction positions on revolving the microscope stage. It also reveals diagnostic refractive indices when examined by the immersion

method. The U.S. Food and Drug Administration standard requires a maximum moisture content of 1.5% for crystalline sodium or potassium penicillin and 2.5% for other forms. The greater stability of the crystalline forms is probably, at least in part, due to their lower moisture content. Crystalline penicillin is required by the Food and Drug Administration to lose not more than 10% of its activity during 4 days at 100°. Yellow penicillins under similar conditions frequently lose 90% of their activity.

The stability of crystalline penicillin is such that the dry substance does not need any special care as regards the temperature at which it is stored and even with the less stable yellow varieties it is sufficient for practical purposes in temperate climates to store the more potent products in a cool place. In both instances, it is essential that the place of storage be dry, since the rubber bung used to close the common type of container is not always moisture-proof. Most published work on the stability of solid penicillin at different temperatures is vitiated by a failure to distinguish clearly between the effect of temperature and that of moisture, either originally present or absorbed through the closure. Randall *et al.* (J. Amer. Pharm. Assoc. 1945; 34, 110) showed that with low-grade penicillin in sealed ampoules the effect of temperature on the rate of decomposition varied with the origin of the sample but deterioration was always relatively rapid at 56°C.; most samples retained their potency at 37° for a month and for longer periods at lower temperatures.

Aqueous solutions of crystalline sodium penicillin G show maximum stability at pH 6 (Benedict *et al.*, J. Bact. 1945, 40, 85; 1946, 51, 291); solutions of pH 6-6.5 show no significant loss during 7 days at 8-14°, but outside this range deterioration (which proceeds logarithmically) is rapid, especially at acidities above pH 4.5 (Molinas and Welch, T. Amer. Pharm. Assoc. 1947, 36, 41). The other penicillins, especially penicillin K, are less stable. Rise of temperature has a considerable effect on stability, a rise of 10° causing a three-fold increase in the rate of decomposition. Solutions of yellow sodium penicillin in general show the same order of stability as solutions of crystalline material but some samples show enhanced stability, while relatively crude batches such as occurred in the early days of penicillin give markedly less stable solutions. The decomposition of penicillin in solution is due to hydrolytic opening of the oxygen ring with formation of penicilloic acid. Thus there is a gradual increase in the acidity of the solution and consequently an autocatalytic action resulting in a progressively increasing rate of deterioration (Lester Smith, Quart. J. Pharm. 1946, 19, 309). Crude penicillin probably contains an inactivator, of unknown nature, which is removed during purification; the purer forms of yellow sodium salt probably contain a substance having a buffer effect and limiting the change of pH which would otherwise result from the hydrolytic decomposition (Lester Smith, *l.c.*); solutions of yellow penicillin are therefore more stable as a rule than solutions of crystalline material. The addition of buffers to solutions

tends to retard deterioration and various substances have a stabilising effect independent of buffer action, notably sodium citrate, sodium hexametaphosphate (Lester Smith, *I.e.*) and sodium phosphate (Pratt, J. Amer. Pharm. Assoc. 1947, 36, 69).

In solution, the salts of heavy metals such as copper, zinc, and mercury favour decomposition, especially in the presence of air, but in their absence dry penicillin is stable towards atmospheric oxygen. Alcohols have a slow action, due to formation of penicilloic acid esters, and glycerol also has a destructive effect, borne varieties of rubber, both natural and synthetic, cause rapid destruction, and care is consequently necessary in selecting any rubber which is to be used in connection with penicillin (Cowan, *Lancet*, 1945, 1, 178; Thomas, *Brit. Med. J.* 1945, 2, 508, 741). *p*-Chlorophenol and cresol are to be preferred to alcohol as antiseptics in injections of penicillin, since they do not so readily produce a turbidity. Phenol also is satisfactory.

Bacterial contamination is a most important factor in the stability of penicillin solutions. Many bacteria produce enzymes, collectively referred to as "penicillinase," which rapidly hydrolyse penicillin and thus destroy its activity.

Penicillinase is much more stable than penicillin and is destroyed only on relatively prolonged boiling. Aqueous preparations of penicillin which are intended to be stored for a time must therefore be prepared and kept under sterile conditions. This is especially necessary with preparations which are of such a composition as to favour the development of bacteria.

CHEMISTRY.

From 1943 until the end of the Second World War, it is probable that more chemists were working on the constitution and synthesis of penicillin than had ever before collaborated on a

single substance. Thirty-nine teams in British and American industrial and academic institutions were involved. The constitution of the various penicillins was established with almost complete certainty and synthesis was accomplished, but only in extremely low yield. A monograph which will give a detailed account of this work is in course of preparation (1947) by British and American chemists, but summaries covering certain aspects of the collaborative research have been released for publication (*see, e.g.* *Nature* 1945, 156, 766; *Science*, 1946, 104, 431).

The first crystalline derivatives of penicillin to be described were penicillamine (Abraham, Chain, Baker, and Robinson, *Nature*, 1943, 151, 107) and penillic acid (Duffin and Smith, *ibid.* 1943, 151, 251). Later, penicillin itself was crystallised as the sodium salt, following purification by various chromatographic procedures, including adsorption chromatography on alumina and other substances, and two modified forms of partition chromatography (Martin and Synge, *Biochem. J.* 1941, 85, 1358). The latter technique was made applicable to acids such as penicillin, which are readily extracted from water by organic solvents, by incorporating an alkaline-earth carbonate with the damp silica used to prepare the column, or by moistening the silica with a strong buffer solution instead of with water (B.P. 569844; Catch, Cook, and Heilbron, *Nature*, 1942, 150, 633).

Some confusion was at first created by the fact that crystalline penicillins isolated in Britain and America had different properties. It is now known that there are at least six different naturally-occurring penicillins: they all have the same ring structure but differ in the nature of the side-chain. The empirical formula is  $C_9H_nO_4SN_2R$ ; the R groups with the names of the corresponding penicillins in the three terminologies now current, are tabulated below:

Penicillin.			R
I	F,	J <sup>2</sup> -pentenylpenicillin	—CH <sub>2</sub> CH:CHCH <sub>2</sub> Me
II	G	benzylpenicillin	—CH <sub>2</sub> -C <sub>6</sub> H <sub>5</sub>
III	X	<i>p</i> -hydroxybenzylpenicillin	—CH <sub>2</sub> C <sub>6</sub> H <sub>4</sub> OH ( <i>p</i> )
—	K	<i>n</i> -heptylpenicillin	-[CH <sub>2</sub> ] <sub>7</sub> -Me
—	Dihydro F	<i>n</i> -amylpenicillin	—[CH <sub>2</sub> ] <sub>5</sub> -Me
—	Flavacidin	J <sup>3</sup> -pentenylpenicillin	—CH <sub>2</sub> CH <sub>2</sub> CH:CHMe

The last, flavacidin, is only known to be produced by the mould *Aspergillus flavus* (Fried *et al.*, *J. Biol. Chem.* 1946, 163, 341), but all the others are produced in various proportions by the mutant strains of *Penicillium chrysogenum* commonly used for production of penicillin by submerged culture. Penicillin I or F was the predominant product from the early strains of *P. chrysogenum* grown on certain synthetic media and was the first penicillin to be isolated by the British teams. The name "penicillin IV" was given to a variety of penicillin of unknown composition obtained by Goodall and Levi (unpublished). It is not identical with penicillin K.

The addition to the medium of phenylacetic acid, and other compounds carrying the benzyl group, tends to increase not only the total yield

of penicillin, as previously stated, but also the proportion of penicillin II (G or benzylpenicillin) in the mixture. Analogous compounds, carrying the *p*-hydroxybenzyl group, tend to increase somewhat the proportion of penicillin III (X or *p*-hydroxybenzylpenicillin). A number of "unnatural" penicillins have been prepared by this kind of partial biosynthesis using appropriate precursors. Another series of penicillins have been made by chemical modification of penicillin III, exploiting the reactivity of this phenolic compound with, *e.g.*, diazonium compounds.

The structure of the penicillins is probably best represented by formula (1) comprising fused thiazolidine and β-lactam rings. The incipient azlactone grouping of formula (2) is a less likely alternative. The oxazolone structure shown in formula (3), although now discredited, is in-

eluded because it inspired a good deal of the earlier synthetic work.

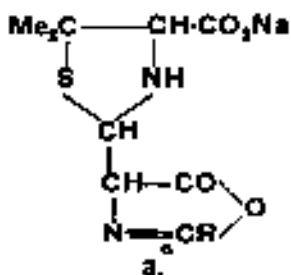
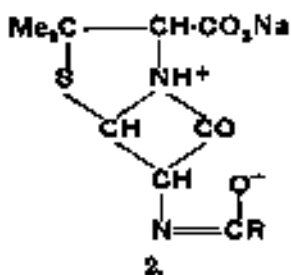
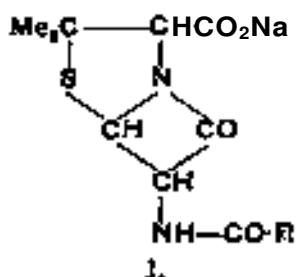

The penicillins are strong monobasic acids (pK about 2.8) containing no basic group. Degradation by various means leads to a characteristic amino-acid, penicillamine. This was found to be d-1S-dimethylcysteine, a structure confirmed by synthesis. It is noteworthy that this amino-acid belongs to the "unnatural" or d-series. Mild oxidation yields the disulphide, tetramethylcystine; more vigorous oxidation gives dimethylcysteic acid or penicillaminic acid. Many other derivatives are known, including a series of thiazolidines arising from reaction of penicillamine with aldehydes and ketones.

The  $\beta$ -lactam ring of penicillin is unusually reactive. Dilute aqueous alkali opens it quantitatively in a few hours at room temperature with consumption of one molecule of alkali to yield the salt of the dibasic penicilloic acid. Methyl alcohol yields a monomethyl ester of the same acid (formula 1). Diazomethane, on the other hand, yields the methyl ester of penicillin itself which, although almost inactive against bacteria, regains *in vitro* activity on mild hydrolysis and also exhibits *in vivo* activity in suitably infected mice. On degradation with aqueous mercuric chloride, this methyl ester yields the methyl ester of penicillamine, thus identifying its carboxyl group as the acidic group in penicillin. This was confirmed by other degradations. For example, benzylamine reacts with penicillin II by the addition of one molecule of water to the penicillin molecule as well as two molecules of benzylamine, to yield the benzylamine salt of

the monobenzylamide of penicilloic acid (formula 5). With mercuric chloride this yields penicillamine and penaldic acid benzylamide, characterised by catalytic reduction to hexahydrophenylacetylserine hydrobenzylamide (formula 6) and comparison with a synthetic specimen

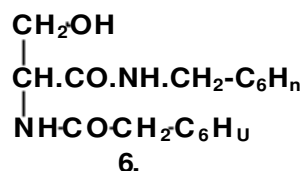
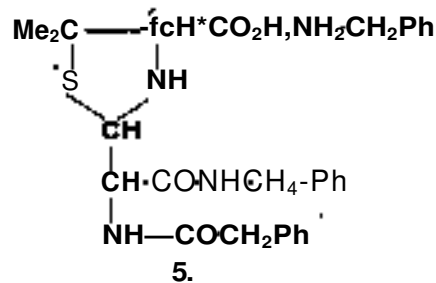
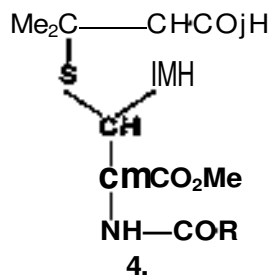

Similarly, benzyl penicilloic acid methyl ester on degradation yields penicillamine and the methyl ester of benzylpenaldic acid, which on reduction gives hexahydrophenylacetylalanine.

Hydrolysis of the penicillins with hot dilute acid yields, besides penicillamine, one molecule of carbon dioxide and the corresponding penaldic aldehydes. Thus penicillin (I or F) yields hexenoylaminoacetaldehyde; amygdalin penicillin (dihydro-F) yields n-hexoylaminoacetaldehyde (isolated as 2:4-dinitrophenylhydrazones). Benzylpenicillin (II or G) gives phenylacetic acid, phenylacetamide, phenylacetic acid, and phenylacetylaldehyde. The carbon dioxide was thought to arise by decarboxylation of an unstable acid, probably a penillo-aldehyde-carboxylic acid,

#### CHOCH(COOH)NHCOR

This supposition was proved correct by several lines of evidence; the acid is a penaldic acid, already mentioned above. When aqueous solutions of sodium benzylpenicillin are heated with Raney nickel, sulphur is removed from the molecule yielding dethiobenzylpenicillin,



in which the  $\beta$ -lactam ring is left intact. A second product of the reaction is phenylacetyl-alanyl-d-valine,  $\text{C}_{16}\text{H}_{22}\text{O}_4\text{N}_2$ , in which this ring is opened reductively.



The structures have also been determined of the acid inactivation products, the penillic acids, and their degradation products. Their formation is now known to involve extensive rearrangement of the molecule, but failure to recognise this in the early stages led to some confusion in attempts to deduce the structure of penicillin. The reaction is accompanied by a large increase in optical rotation. The penillic acids being sparingly soluble in water are readily isolated in crystalline form, even from relatively crude penicillin. They are dibasic acids with one basic group, but devoid of a thiol group. Penillic acid is isomerised to isopenillic acid by baryta, the thiazolidine ring being opened to exhibit a thiol group. With cold aqueous mercuric chloride the penicilic acids are converted to the corresponding penillamines, which are decarboxylated to isopenillic acids. The penillamines are stable to hot dilute acid but the penillic acids yield penicillamine, carbon dioxide, and the corresponding penillo-aldehyde, like the penicillins themselves. The structures 7, 8, and 9 for penillic acid, isopenillic acid, and penillamine have been confirmed by synthesis.

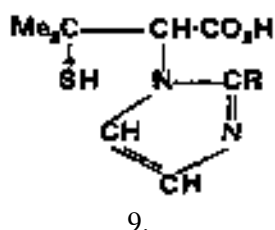
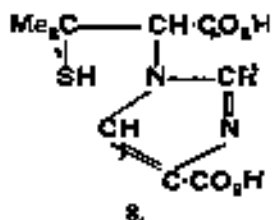
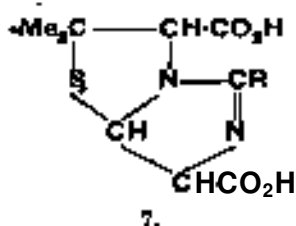

Penicillin was synthesised early in 1944 almost simultaneously by British and American teams (du Vigneaud *et al.*, Science, 1946, 104, 4C). The products had an activity of only about 0.5 unit per mg., later raised to 3-6 units per mg. (compared with 1,667 units per mg. for pure sodium benzylpenicillin), and it was not certain at the time whether this was really due to penicillin or to some antibiotic by-product. Many lines of evidence, however, combined to prove that penicillin was present and the matter has been checked by the isolation of synthetic penicillin as a pure crystalline salt (du Vigneaud *et al.*, Lc).

The synthesis was accomplished by reaction between synthetic optically resolved d-penicillamine and a suitably substituted oxazolone

bearing a potential aldehyde group, such as 2-benzyl-4-methoxymethylene-6(4)-oxazolone (formula 10; R=C<sub>7</sub>H<sub>7</sub>; R'=CH<sub>3</sub>) or 2-styryl-4-ethoxymethylene-5(4)-oxazolone (formula 10; R=C<sub>8</sub>H<sub>7</sub>; R'=C<sub>2</sub>H<sub>6</sub>)

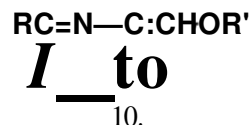

The use of *i*- instead of *rf*-penicillamine gave no antibiotic activity. The synthetically produced antibiotic exhibited the same degree of stability towards a number of reagents as did natural penicillin, and the two materials showed the same "bacterial spectrum," *i.e.*, the same relative activity against 7 different bacteria. The synthetic material, like natural penicillin, was inactivated by the enzyme penicillinase. More conclusive evidence of identity was afforded by the isotope "tracer" technique. Penicillamine containing radioactive sulphur was condensed with the oxazolone, the product mixed with natural penicillin and crystallised as the triethylamine salt. This product, and also sodium penicillin and penillic acid prepared from it, carried the expected proportion of radioactive sulphur.

Some concentration of the synthetic material was effected by counter-current distribution between organic solvents and aqueous buffer solutions, using either partition chromatography or the apparatus of Craig (J. Biol. Chem. 1944, 155, 519; 1945, 161, 321). Improvement in the reaction conditions and repeated application of these fractionation procedures finally led to a concentrate pure enough to yield the crystalline triethylamine salt of benzylpenicillin. This was identical with the salt of the natural substance in melting-point, ultra-violet and infra-red absorption spectra, refractive index, antibiotic activity, and (noteworthy) in optical rotation.

Other synthetic penicillins have been made in similarly small yields, differing not only in respect of the group R, but also in the elimination or alteration of the two methyl groups, by using  $\alpha$ -amino- $\beta$ -mercapto-acids other than penicillamine.

### Assay.

The original unit of penicillin, referred to as the "Oxford unit," was defined as the "amount of penicillin contained in 1 ml. of a certain phosphate buffer solution containing ether" (Heatley, Biochem. J. 1944, 38, 64). This purely arbitrary unit served the purposes of the early investigators but is, of course, useless to others. Penicillin is usually assayed biologically, and the activity of a sample under test can only be determined by simultaneous comparison, under conditions as nearly as possible identical, with a stable standard preparation.

The first British standard preparation, known as the Provisional British Standard, was created in 1944. It consisted of very impure material and was assigned a potency of 155 Oxford units per mg. In America a master standard, believed to consist of crystalline penicillin 6, was assigned a potency of 1,650 units per mg. Later in 1944,

an international conference, held under the auspices of the Permanent Commission on Biological Standardisation of the Health Organisation of the League of Nations, agreed to the setting up of an international standard. This preparation is believed to contain 99.75% of penicillin G and 0.25% of penicillin F. The international unit of penicillin is defined as the activity contained in 0.6 microgram of the International Standard Preparation; it is approximately the same as the original Oxford unit. The international Standard Preparation is stored and distributed by the Department of Biological Standards, National Institute for Medical Research, Hampstead, London, N.W.3. For a full account of the preparation of the standard and of the manner in which it was assayed, see Quart. Bull. Hlth. Org. L.o.N., 1945-46, 12, 250. An international working standard was also established for use in checking national standards in those countries which have set them up.

The assay procedure which in one form or another has come into almost universal use was originally devised by Heatley (see Lancet, 1941, 2, 177); it is referred to as the "cylinder plate" method and its advantage is that sterility of the solutions to be tested is not necessary. A suitable agar medium is poured into petri dishes and allowed to set. The plates are seeded with the test organism, commonly *Staph. aureus*, by pouring a broth culture on to the surface of the agar, draining off the excess, and drying. Small open-ended cylinders about 1 cm. high and 0.5 cm. internal diameter, usually made of glass or porcelain, are then placed gently on the agar plates so as just to break the surface, four or five being equally spaced in a circle on each petri dish. The solution of penicillin to be tested is prepared in 0.1 M. phosphate buffer at pH 7 and diluted with more of the same phosphate buffer to produce "dilutions containing about 0.5, 1.0, 1.5, and 2.0 units per ml. Solutions of the standard penicillin of about the same concentration are also prepared. The dilutions of the unknown and of the standard are pipetted into the cylinders, and the dishes are covered and incubated at 37° for 12-18 hours. The penicillin solutions diffuse out through the agar at the base of the cylinders and prevent the growth of the test organism so that a clear (circular) zone is formed around each cylinder. The diameter of the clear zone is a function of the concentration of the penicillin in the solution contained in the corresponding cylinder; it is approximately proportional to the logarithm of the concentration. It is important to note that owing to this logarithmic relation a comparatively small difference in ring diameters may denote a large difference in penicillin concentrations; consequently it is essential that the standard and the unknown are handled as nearly as possible in exactly the same way. Many seemingly insignificant points of divergence in treatment may however occur. For example, the position of a cylinder in relation to the point where the excess of the culture of the test organism is poured off may affect the zone diameter, and so also may the position of a plate in the incubator. Where large numbers of assays are involved, these

sources of error can to a large extent be obviated by conducting assays on a range of dilutions of the 'standard preparation and constructing a "standard curve" connecting ring diameters and quantity of penicillin, a standard curve being constructed for each day's work. The concentration in an unknown solution can then be read off on this curve from the ring diameter observed. In order to confirm that the curve is applicable to any particular unknown it is advisable to include one cylinder of standard on each plate of unknown. If there is a divergence between the ring diameter obtained with the standard and that corresponding to the same quantity of standard as shown on the standard curve, a proportional correction can be applied.

In an attempt to eliminate as many variables as possible in the assay the U.S. Food and Drug Administration have described the procedure in considerable detail, and given specifications for the medium and its ingredients (Federal Register, 1947, 12, 2217). They have also adopted the statistical method of Knudson and Randall (J. Bact. 1945, 50, 187) for calculating the results. Bliss (J. Amer. pharm. Assoc. 1946, 35, 6) has described another procedure which is statistically more valid.

One of many modifications of this procedure, the cylinders are replaced by holes cut in the agar medium by, for example, a cork borer. If this is adopted the solutions to be assayed should be sterile. In another variant the cylinders are replaced by discs of sterile filter paper, 1 cm. in diameter, which are dipped in the solutions to be assayed, drained, and placed in position on the plate.

Whichever modification is adopted, the assay should be conducted in triplicate or, preferably, quadruplicate and if possible repeated on another day. With the precautions indicated above the error probably does not usually exceed  $\pm 10\%$ . The species and strain of test organism used have a considerable influence on the result, since most samples to be assayed will contain mixtures of different penicillins and the effect on the growth of the test organism will depend upon its sensitivity to the different varieties and the relative proportions in which they are present.

As an alternative to the plate methods of assay, the serial dilution method can be used, but the test and standard solutions must be sterile. In this method a comparison is made of the volumes of the unknown sample and of the standard solution which just inhibit growth of the same volume of a broth culture of the test organism. A detailed account of the conduct of both cylinder plate and serial dilution assays is given in the British Pharmacopoeia. The U.S. Pharmacopoeia XIII prescribes the assay of penicillin and its preparations; the procedures adopted by the Food and Drug Administration (see Federal Register, *I.e.*),

Micro-scale biological methods of assay have been developed and are of particular value for making determinations of the penicillin content of the blood and other body fluids. Fleming (Lancet, 1944, 2, 621) has described a "slide-cell" method, in which a serial dilution procedure is carried out on microscope slides, and a capillary tube method.

**Non-biological Methods.**—The development of chemical and physical methods of assaying penicillin had to await partial elucidation of its structure. The first to be described was the polarographic method of Page (unpublished). The thiazolidine ring\* is opened by hydrolysis, first with alkali, then with acid, and the liberated —S H group is determined by the very sensitive catalytic cobalt step. This method can be used with relatively small amounts of penicillin and it has about the same accuracy as the cylinder plate procedure; unfortunately it is, no less time-consuming.

Later methods depend on the hydrolytic or ammonolytic opening of the lactam ring. Two methods have been described, one colorimetric, the other fluorimetric; in both the ring is opened by coupling the penicillin with an ethylenediamine derivative. In the colorimetric method (Scudi, *J. Biol. Chem.* 1946, **164**, 183) the compound employed is *N*-(1-naphthyl-4-azobenzene)ethylenediamine. Penicillin solution is acidified and shaken with ether to extract the free acid and the coupling is effected in benzene solution with a little acetic acid as catalyst. Excess of the basic reagent is removed by washing with acid; the acidic penicillin complex is removed with alkali and determined colorimetrically. In the fluorimetric method (Scudi and Jelinek, *ibid.* 1946, **164**, 194) the compound used is 2-methoxy-6-chloro-9-(*N*-ethylenediamine)acridine, but the procedure is otherwise similar. These methods, especially the fluorimetric, are very sensitive and with care, can be made more accurate than biological procedures. The many manipulations involved are, however, tedious and readily introduce errors.

The simplest chemical procedure is a modified saponification-value determination. The penicillin solution is adjusted to about pH 8, a measured excess of alkali is added and after about 3 hours at room temperature the remaining alkali is back-titrated with standard acid to the initial pH. Most conveniently about 0.1 g. of penicillin is used per assay, which permits use of *N*/100 reagents and an indicator (*e.g.*, Presol Red). With smaller quantities of penicillin or with highly coloured samples electrochrometric titration is preferable. When highly potent penicillinase is available even the back titration can be avoided. After adjustment to pH 8 penicillinase is added, and the penicilloic acid produced is titrated with alkali, added in portions if necessary to maintain the solution near the pH optimum for the enzyme, *i.e.*, about pH 7. Crude penicillinase preparations contain too much buffering material to be suitable.

Several oxidation methods have been proposed. Hydrogen peroxide, for example, in presence of a trace of heavy metal catalyst, besides releasing the potential carboxyl group produces another acidic group by oxidising the S to a sulphonic acid, thus giving two acidic groups per molecule to titrate. More convenient and sensitive, however, is the iodometric method of Alicino (*Ind. Eng. Chem. [Anal.]*, 1946, **18**, Q19), which is recognised by the U.S. Food and Drug Administration in the test for the stability of crystalline penicillin (Federal Register, 1947, 12, 2222). The lactam ring is opened with

*N*. alkali, the solution is acidified and *N*/100 iodine is added; after 15 minutes standing the excess iodine is titrated with *N*/100 thiosulphate; 1 mg. of pure sodium penicillin G corresponds to 2.52 ml. of *N*/100 iodine. The method is empirical, 7-9 atoms of iodine being required per molecule according to conditions, which have to be closely standardised, while standard penicillin should be used as a control. A blank titration is necessary, omitting the alkali treatment, to correct for penicilloic acid or other oxidisable impurities present. A further source of error is that the different varieties of penicillin have slightly different molecular weights and consequently the weight of each which is equivalent to unit volume of standard iodine is not identical. For this reason the method cannot give the same results as the biological procedures except with a solution of a single variety of penicillin when a pure specimen of the same variety is available for use as a standard in the biological test.

**Separation and Assay of Individual Penicillins.**—When present in complex mixtures, as is usual from manufacture by submerged culture, the penicillins are not easy to separate or assay individually. "Differential assays" which take advantage of differences in response to two organisms, usually *Staphylococcus aureus* and *Bacillus subtilis*, can be used for suitable binary mixtures, *e.g.*, of penicillin II with either penicillin III or penicillin K; the accuracy is low and there is seldom assurance that other penicillins are absent.

Partition methods are available in certain instances. Penicillin III, by virtue of its phenolic group, is less readily extracted than the other penicillins from acidified aqueous solutions by organic solvents, especially chloroform, and nearly complete separation can be effected by this means. Conversely, the long side-chain of penicillin K renders it the most readily extracted by solvents. Differences in partition coefficients are not great enough to permit complete separation, but at the most favourable pH values, namely 5-6, chloroform extracts much of this penicillin and only small proportions of the others. Dihydropenicillin I and penicillin I are more readily extracted than penicillin II, but the differences are too small to permit separation unless multiple countercurrent extractions are employed. This can be done most practically with modifications of partition chromatography. For example, Fischbach *et al.* (*Science*, 1946, **104**, 84) have described a technique applicable to the determination of penicillin K in mixtures. Goodall and Levi (*Nature*, 1946, **158**, 675; *Analyst*, 1947, 72, 277) have described a modification of the paper strip chromatography of Consden, Gordon, and Martin (*Biochem. J.* 1944, 38, 224) for the determination of all the penicillins present in mixtures. Strips of filter paper are soaked in strong buffer solutions (pH 6-7) and dried. A spot of penicillin solution, containing 2-30 i.u. in 1  $\mu$ l., is applied near one end, and this end is then bent over and dipped in a trough of ether, while the rest of the strip hangs vertically in a chamber saturated with water vapour and ether. After about 20 hours at 0-5°C. the strip is placed on a large

sheet of nutrient agar, seeded with spores of *Bacillus subtilis*, which is incubated overnight, after remaining cold a few hours to allow penicillin to diffuse from the strip. The various penicillins become visible as elliptical zones of inhibition along the strip, arranged in order of partition coefficients. The proportions present can be calculated from the widths of the zones.

Some chemical methods have been suggested for assay purposes. For example the phenolic group of penicillin X should lend itself to determination, as also the unsaturated side-chain of penicillin F. A specific method for penicillin G based on nitration of the benzene ring has been proposed by Page and Robinson (Nature, 1946, 158, 910).

It has been claimed that the proportion of penicillin II in a mixture of pure penicillins can be determined by its exclusive precipitation as crystalline ethylpiperidine salt from a mixture of amyl acetate and acetone under controlled conditions (Sheehan *et al.*, J. Amer. Chem. Soc. 1946, 68, 2407). This method is adopted by the U.S. Food and Drug Administration (Federal Register, 1947, 12, 2222).

PHARMACOLOGY.

The importance of penicillin arises from a, so far, unique combination—an almost complete absence of toxicity and a high antibacterial activity against a wide range of common pathogenic organisms even in the presence of body fluids. The action on bacteria is bacteriostatic at low concentrations and bactericidal at high; in some instances it is effective against spores as well as against vegetative forms. Probably it interferes with some vital function of cell life, but the mode of action has not yet been elucidated. The following Table gives some of the pathogenic organisms commonly regarded as susceptible and resistant, respectively, to penicillin.

Susceptible.	Resistant.
Actinomyces.	<i>Bacillus proteus</i> .
<i>if. anOtracis</i> .	<i>Bacillus typhosus</i> and <i>B. paratyphosua</i> .
Glostridia.	Brucella.
<i>Corynebacterium dipk-therise</i> .	Eseherichia coil.
Gonococcus.	<i>Hsemophilua injlutnzse</i> .
Meningococcus.	<i>Hsemophilus pertussis</i> .
Pneumococcus.	<i>Mycobacteriuvl tuber-culosis</i> .
Stapnylococtus.	<i>Pseudomorias pyo-tyann</i> .
Streptococcus.	Trypanoames,
<i>Treponavia pallidum</i> .	Viruses.

In connection with the above Table it must be remembered that the terms susceptible and resistant are relative; sensitivity varies very widely with different strains, even of the organisms listed as susceptible.

The following figures (Meads *et al.*, J. Lab. clin. Med. 1945, 30, 725) show the range in sensitivity among strains of common pathogens:

Organism,	Penicillin concentration required to kill in broth culture.		
	Least sensitive, i.u. per ml.	Most sensitive, i.u. per ml.	Majority, i.u. per ml.
Gonococcus	0.008	0.002	0.004
<i>^</i> -Streptococcus	0.02	0.004	0.003
Pneumococcus	0.06	0.008	0.03
<i>a</i> -Streptococcus	0.13	0.008	0.03
Meningococcus	0.5	0.02	0.13
<i>Staph. aureua</i>	2.0	0.02	0.06
<i>Hmmopkilus hmmolyticus</i>	0.5	0.03	0.06

The following Table gives an indication of the activity of the four main varieties of penicillin against typical strains of pathogenic organisms (Eagle, J. Path. Bact. 1940, 62, 81). The figures represent the *in vitro* activities of penicillins F, X, and G compared with that of penicillin G taken as 100 in each instance:

Variety of penicillin.	Relative activity per nig. against		
	Staphylo-cocctis.	Strepto-coccus,	<i>Treponema patHUum</i> .
<b>G</b>	100	100	100
<b>F</b>	90	82	53
<b>X</b>	54	140	51
<b>K</b>	138	120	76

The objective in therapeutic administration is to maintain an Effective level in the blood stream for as long a period as possible, preferably continuously.

Dosage schemes may be based either on the frequent or continuous injection of relatively small amounts or on the injection of larger doses at longer intervals. The former method is more economical in the amount of penicillin used but is possible only in hospital practice. Injections are commonly given every 3 hours, total dose in 24 hours being 100,000-500,000 units. In the alternative procedure, doses may be given once or twice a day, each dose being from 50,000 to 1,000,000 units or more. After reaching the bloodstream the greater part of each dose is excreted through the kidneys. Numerous attempts have been made to prolong the action by retarding the rate of absorption or of excretion but they have not been very successful. The most widely used preparation is a suspension of calcium penicillin in arachis oil and beeswax (Romansky and Rittmann, Science, 1944, 100, 196). Viscous preparations of this character are inconvenient to use; more fluid preparations can be made, but appear to give a less preferred action (Ungar, Quart. J. Pharm. 1946, 19, 544; see also, however, Berger, *ibid.* 1947, 20, 22). Oral administration is relatively ineffective owing to the destructive action of the digestive juices and intestinal bacteria. Some clinical effect can be produced by giving large oral doses, especially in combination with a buffer. Esters of penicillin, such as the methyl and benzyl derivatives, are effective orally in some experi-

mental animals, but apparently they are not hydrolysed in man-

The difficulty of separating the different penicillins present in the mixtures resulting from normal commercial manufacturing procedures has prevented investigation of their relative merits in different conditions. Penicillin K is more rapidly excreted than penicillin G and it is also more readily destroyed in the body; consequently it is, in general, less effective on a weight for weight basis.

Pharmacy.—Penicillin has been used in a wide variety of preparations, including lozenges, pastilles, chewing wafers, dusting powders, ointments, creams, lotions, sprays for the nose, throat, and bronchial passages, snuffs and suppositories. For full particulars of these, reference must be made to text-books of pharmacy. Olcium penicillin, being less hygroscopic than the sodium salt, is preferred for use in such preparations since it can be handled more easily. Preparations made with crystalline sodium penicillin are less stable than those made with the calcium salt, an observation which is in keeping with the known stabilising effect of some impurities. For injections a sterile aqueous solution of the sodium salt is most commonly used; the solution is made by injecting sterile water through the rubber closure of the vial containing the penicillin. Suspensions of the calcium salt in oil and beeswax, which are claimed to give a more prolonged action (*see above*), are also extensively used. They have to be warmed before use since otherwise they are too viscous, and it is difficult to cleanse the syringe after the injection has been given. The oily injections are, therefore inconvenient and messy. Ointments and creams, which are to be applied to wounds where the skin is broken, are supplied in sterile condition. The same applies to preparations of such a nature that penicillinase may be produced if an appropriate organism gains access, and for this reason all aqueous preparations should be supplied in a sterile condition unless, they are likely to be used within a few hours. In any event, preparations containing water are unstable and should be used as rapidly as possible; they should be stored, if at all, in a refrigerator. It is desirable that the moisture content of all preparations not containing water as an ingredient should be as low as possible; for preference the non-penicillin ingredients should be dried before incorporation. When this is done the rate of deterioration of non-aqueous preparations is relatively small and no special care is necessary in storing them other than to ensure that moisture cannot gain access; it is, however, always advantageous to keep penicillin preparations in a cool place as is available.

Urinary Use.—The restriction in the amounts of penicillin that have been available for human use has prevented the same development in the use of the substance for veterinary purposes. It has, however, been used to a considerable extent for the treatment of bovine mastitis, but its effect necessarily depends on the susceptibility of the infecting organism. One of the most common infecting organisms is *Streptococcus agalactiae* which is penicillin-

sensitive. Infections with *Staphylococcus aureus* seem less readily cured. Treatment is by injection of a sterile aqueous solution into each quarter of the affected udder. Oily suspensions have also been given but such preparations are not easy to use.

#### Legal.

In Great Britain penicillin and its injectable preparations are controlled by Regulations (S.P. & O. 1946, No. 467) issued under the Therapeutic Substances Act, 1925. The effect is that the controlled substances may be manufactured for sale only by those who are licensed so to do by the Ministry of Health in England and Wales, by the Department of Health for Scotland in the latter country, and by the Ministry of Home Affairs in Northern Ireland. Licences are granted only when the licensing authorities are satisfied with the conditions under which the preparations will be made. The Regulations also specify standards for potency and tests for sterility and for freedom from pyrogenic substances, and lay down various requirements in regard to labelling.

Control of the sale and distribution of penicillin and all preparations containing it is exercised by the Penicillin Act, 1947. This Act makes it an offence to sell the substance, or anything containing it, direct to the general public. In general such products may be sold by pharmacists only to medical practitioners, dental surgeons, and veterinary surgeons, and the general public may obtain supplies only on prescription.

In the United States, standards and tests, packaging and labelling are controlled by the Food and Drug Administration under an amendment of the Federal Food, Drug, and Cosmetic Act, dated 6th July, 1945. Penicillin and its preparations must be certified by the Administration before they can be dealt with in interstate commerce.

H. T. B., A. H. C., and E. L. S.  
PENTAMIDIN E. 4:4'-Diamidinodiphenoxypentane. Drug used for treatment of trypanosomiasis and Kala-azar (*v.* SYNTHETIC DRUGS).

S. E.

PENTLANDITE. A sulphide of iron and nickel, nearly (Fe,Ni)S, usually with Fe:Ni close to 1:1. Recent analyses indicate that the formula is more correctly (Fe,Ni)<sub>9</sub>S<sub>8</sub>, and that the mineral may contain small amounts of cobalt. The pure mineral contains approximately 34.5% of nickel. It crystallises in the cubic system, and is almost always found as granular aggregates intimately associated with the magnetic iron sulphide, pyrrhotite, and also commonly with chalcopyrite. Pentlandite has a prominent octahedral parting, a yellowish-bronze colour, and metallic lustre. It is brittle, opaque, and non-magnetic;  $\rho$  4.6-5; hardness 3-4. Although pentlandite is not unlike pyrrhotite in appearance, it can be distinguished from it by the octahedral parting, lack of magnetism, and absence of anisotropism when examined in polished sections in vertical reflected light. Its presence is readily detected by the dimethylglyoxime test for nickel.

Pentlandite is the principal ore mineral of nickel. In the famous deposits of Sudbury, Ontario, which have yielded during the past decade about 85% of the world production of nickel, the metal is derived almost entirely from pentlandite. Other nickel-bearing sulphide deposits in which pentlandite is practically the only source of nickel are those of Petsamo in Finland, Norway, British Columbia, and Norilsk in Siberia.

D. W.

**PENTOBARBITAL** (*h.* "NEMBUTAL," Vol. VIII, 450*d.*; PENTOBASBITONE SOLUBLE).

**PENTOBARBITONE SOLUBLE!**  
Sodium 5-ethyl-5- $\alpha$ -methylbutylbarbiturate. "Nembutair" Sedative, hypnotic, and anesthetic. B.P. Add. VII, B.P.C. Supp. VII (t. SYNTHETIC DRUGS).

S. E.

**PENTOTHAL.** Sodium 6-ethyl-5- $\alpha$ -methylbutyl-2-thiobarbiturate. Anaesthetic (intravenous) (*v.* SYNTHETIC DRUGS).

S. E.

**PEONIDIN** is the anthocyanidin obtained by the acid hydrolysis of peonin (*q.v.*). Willstätter and Nolan (Annalen, 1915, 408, 136) using hot 20% hydrochloric acid found that peonidin chloride crystallised from the solution in the form of slender needles of the *monohydrate*,  $C_{17}H_{13}O_6Cl \cdot H_2O$ , which superficially resembled one of the forms of cyanidin chloride. By transmitted light the peonidin salt is reddish grey-brown, while the cyanidin salt is more bronze brown-red. In its high solubility in alcohol, in the fine, violet-red colour of the solution, and in its behaviour towards hydrochloric acid, sulphuric acid, and sodium carbonate, peonidin resembles cyanidin. In other respects the two anthocyanidins show widely different properties. Peonidin chloride is fairly easily soluble in cold water forming a brownish-red solution, and very easily on warming, whilst cyanidin chloride is very sparingly soluble. (A hot dilute aqueous solution of peonidin chloride decolorises rapidly owing to *pseudo-base* formation.) Water added to a concentrated solution of peonidin chloride in alcohol changes the colour to brownish-red; under the same circumstances violet flocks separate from a solution of cyanidin. A violet colour develops when potassium acetate is added to an alcoholic solution of peonidin, but there is no important colour reaction with ferric chloride; an alcoholic solution merely becomes more intense. The *chloride* is sparingly soluble in 1% hydrochloric acid (easily on warming) or in stronger acid. The *sulphate* crystallises from 7% sulphuric acid in microscopic brown needles. The *picrate* (brownish-red needles) separates more readily than does that of cyanidin.

The constitution of peonidin (I) as a cyanidin monomethyl ether is established by the following facts: demethylation with hydriodic acid in the presence of phenol affords cyanidin; alkalifusion experiments indicate that the methyl group is attached to the 2-phenyl group of the anthocyanidic. Peonidin has been synthesised by condensing acetylated phloroglucinaldehyde with *cu*-4-diacetoxy-3-methoxyacetophenone and

hydrolysing the acylated flavylum salt formed intermediately (Nolan, Pratt, and Robinson, J.G.S. 1926, 1968).

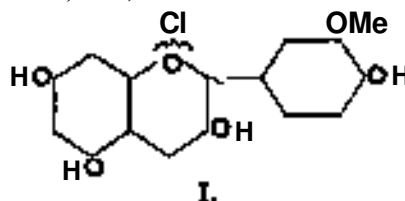

I.

Peonidin derivatives are not very widely distributed in nature. In their survey of anthocyanins, G. M. and R. Robinson (Biochem. J. 1931, 25, 1687; 1932, 26, 1647; 1934, 28, 1712) have observed the presence of a peonidin-3-glycoside in *Verbascum phamiceum*, a 3-pentoseglycoside in a variety of *Cyclamen*, a 3-bioside in *Cosmea bipinnata*, and 3:5-dimonosides in Sweet peas, *Streptocarpus*, *Fuchsia*, and probably in varieties of *Magnolia*.

W. B.

**PEONIN** is the anthocyanin colouring matter of the flowers of deep violet-red peonies. It was isolated by Willstätter and Nolan (Annalen, 1915, 408, 136) by extracting the dried and powdered petals with methyl-alcoholic hydrogen chloride and precipitating *ip* from the filtered solution by adding ether. Partial extraction of the darts-red syrupy product with warm 2% methyl-alcoholic acid dissolved colloidal and hygroscopic substances, leaving a residue which, when stirred with methyl-alcoholic hydrogen chloride containing glacial acetic acid, became granular and then powdery. After extracting again with warm 2% methyl-alcoholic acid, the residue was crystallised from *not* N/2 H Cl. The yield was 6 g. from 1 kg. of powdered petals.

Crystallised as described, peonin chloride forms the *pentahydrate*,  $C_{28}H_{33}O_{16}Cl \cdot 5H_2O$ , consisting of lustrous, bronzy, brownish-red needles, which by transmitted light appear red-violet, and when powdered are brick-red. It melts with decomposition at 165°.

Peonin resembles cyanin closely in many of its properties. The two anthocyanins dissolve in 7% sulphuric acid with the same colour. The rate of *pseudo-base* formation is the same for both, as also are the reactions with sodium acetate (violet), sodium carbonate (blue), and sodium hydroxide (blue, becoming green on standing). The two anthocyanins differ however in their reaction with ferric chloride. Peonin is scarcely affected, whilst cyanin gives a blue coloration. A further difference is observed in the solubility of the salts. In cold water peonin is very easily soluble, the colour quickly fading on account of *pseudo-base* formation. It is also considerably soluble in cold alcohol, in this solvent, too, isomerisation occurs readily. It is sparingly soluble in cold, dilute hydrochloric acid; at 20°, 1 litre of 1% acid dissolves only 0.1 g. of the chloride. In cold 2N- HCl it is insoluble, but it dissolves on warming. The solubility is also greatly increased if impurities are present. Peonin is more sparingly soluble than cyanin in 7% sulphuric acid; it separates from the solution in small red needles. A solution of peonin in 1% ethyl alcoholic hydrogen

chloride is violet-red, redder than a correspond-1 ing solution of cyanin. The pick ate of peonin is very readily formed, crystallising even when picric acid is added to a suspension of the chloride in water; the chloride dissolves and the picrate separates in the form of brownish-red needles, which under the microscope appear red-violet.

Peonidin chloride (1 mol.) and glucose (2 mol.) are formed when peonin is hydrolysed by short boiling with 20% hydrochloric acid. The points of attachment of the glucose units have been ascertained, and the suggested structure of the anthocyanin has been confirmed by a synthesis in which co-tetra-acetyl-β-glucosidoxy-4-acetoxy-3-methoxyacetophenone (II) was condensed with 2-O-tetra-acetyl-β-glucosidylphloroglucinaldehyde (I) to form a flavylum Bait, which was then deacetylated to peonin chloride (III).

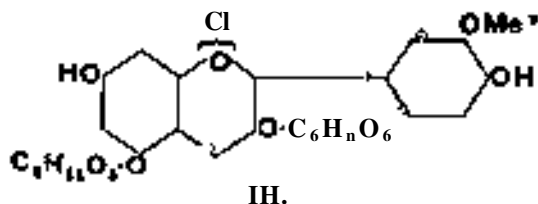
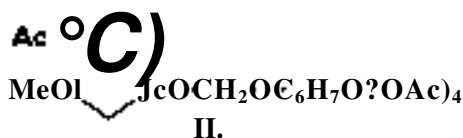
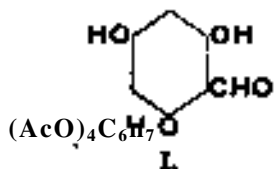

0.164x10<sup>4</sup>%. solutions of both the natural and synthetic chlorides in 0.1% methyl-alcoholic hydrogen chloride show identical absorption spectra with a maximum at about 5,200 Å. (Kobinson and Toda, J.C.S. 1932, 2493).

W. B.

**PEPPER.** The dried fruit of *Piper n* i Linn. (Fam. Piperaceae), indigenous to South India, but cultivated there and also in the West Indies and many tropical countries. The various Long peppers, cubebes, and Betel nuts belong to the same family. The plant is a climbing woody vine growing to a height of 12-20 ft. and supported on poles or trees. The flowers and fruits are sessile, 20-30 growing directly from the flower spikes, and the berries are about 3-5-6 mm., usually about 5 mm., in diameter. Black pepper is gathered when the lower berries begin to turn red, and dried in the sun or by artificial heat, by which process it becomes black and shrivelled. Two crops are collected annually. White pepper, which is a pale buff in colour, is the riper berry taken from one end of the spike or by gathering the whole spike when more mature, and deprived of a portion of the pericarp or outer skin by fermentation, treading down, and washing, or by macerating in water, and then rubbing in baskets to remove stalks

and pulp. The berries, even after this, are larger is than those of black pepper, but the greater degree of ripeness does not show itself in any other respect. The flavour of white pepper is less pungent than that of black pepper and is preferred in Europe, though black pepper is more popular in America. Decorticated white pepper is pepper from which practically all the seed coats have been removed. The process is carried out by the spice miller and the resulting ground product possesses a white colour, a low ash, very little fibre, and—some think—very little flavouring pungency.

The chief varieties of black pepper sold in the market are Mangalore, Malabar, Lampong, Alleppi, Tellicherry, Penang (or Acheen), Siam, Ceylon, and Singapore, the names being taken from the districts in which they are grown, or from the port from which they are shipped. I Trang pepper has now disappeared from the market. The chief varieties of white pepper are White Mantok, Ceylon, and Sarawak.

**Macroscopic Examination.**—Pepper possesses no stalk, as usually understood, at the base, but a small peduncle composed largely of 10-15 fibro-vascular bundles, by which the fruit is attached to the spike and which radiate in all directions in the parenchymatous layer to the apex, below the outer epidermis and the layer of stone cells, so that parts of it are found in white as well as in black pepper. The fruit should be soaked for 24 hours before dissection to soften it. A cross-section shows an outside fruit layer or pericarp composed of an outer epidermis (in black peeper only), a layer of stone-cells, a layer of parenchyma, in which are embedded some oil cells, the fibro-vascular bundles lined with oil cells, a single layer of cells, and a double layer of brown pigment cells. The seed, which lies within the pericarp and which it completely fills, consists almost entirely of perisperm surrounded by a seed coat of three layers and a very thin epidermis. At the apex of the seed there is a small depression below which is the minute embryo and the endosperm. In the centre of the perisperm a cavity is always found in white and generally in black pepper.

**Microscopical Examination.**—The pericarp consists of seven layers: (1) the epicarp consisting of polygonal cells with dark contents and occasional stomata, (2) the hypoderm consisting of thick-walled sclerenchymatous or lignified cells in one or two rows, (3) the outer mesocarp consisting of about twelve rows of thin-walled parenchymatous cells containing oleo-resin cells with crystals of piperine in some of them, (4) the fibro-vascular bundles, (5) the layer of large-polygonal oil cells, (6) the inner parenchymatous layer of small cells with slightly sclerenchymatized walls, and (7) an endocarp layer of beak- or horseshoe-shaped cells heavily sclerenchymatized on the radial and inner walls and which are bright and colourless. The sclerenchyma cells, if previously bleached with sodium hypochlorite, stain yellow fairly readily with zinc chloriodide or deep red with safranin; the parenchyma cells stain blue with zinc chloriodide and light red with safranin. The cells of the hypoderm are characteristic of pepper, some being isodiametric and about 15/10 to 20/10, but the



majority are elongated and measure up to 100 $\mu$ . by 20 $\mu$ . Small oxalate crystals are found in this layer, while simple or compound minute starch grains are found in the parenchymatous layer beneath. When examining powdered pepper it is seldom that the three layers of the seed coat are observed distinctly; they consist of two hyaline layers with a layer of dark reddish-brown pigment cells. The perisperm or seed of the pepper contains abundant food and is composed chiefly of horny protein matter in which numerous starch aggregates are embedded, the starch grains measuring usually about 4 $\mu$ . and seldom reaching 6 $\mu$ ., though when examined carefully they show a distinct hilum. Most of the cells are radially elongated towards the centre

and occasional oleo-resin cells are distributed throughout. \*

Pepper is mainly employed as a condiment, the shells being used for tinned foods, sausages, etc. It has been used since the time of Hippocrates in medicine for its stimulating and carminative properties, though it is no longer official in the Pharmacopoeias.

*Chemical Composition.*—The results of the analysis of various varieties of black and white pepper and of pepper shells by Winton, Ogden, and Mitchell; Winton and Bailey (Ann. Kept. Connect. Exp. Sta. 1898, 198; 1903, 158); Doolittle (Mich. Diary and Food Dept., Bui. 34), and C. Arragon (Ann. Falsif. 1915, 8, 345) are as follows:

TABLE I.

	Black pepper.			White pepper.			Pepper shells.	
	Max.	Min.	Av.	Max.	Min.	Av.	Max.	Min.
Moisture . . . . .	12.95	8.09	10.26	14.47	8.04	10.90	11.01	7.00
Ash, total . . . . .	7.0	3.09	5.02	2.96	0.86	1.50	28.81	7.82
Ash, insoluble in HCl. . . . .	1.8	0.0	0.61	0.20	0.0	0.17	22.90	0.79
Ash, soluble in water . . . . .	3.32	1.65	2.52	1.16	0.12	0.38	4.66	1.53
Starch (Diastase method). . . . .	41.75	22.05	35.64	63.60	48.88	54.97	15.30	2.30
Ether extract, volatile . . . . .	2.78	0.65	1.29	3.58	0.76	1.0*	1.11	0.68
Ether extract, non-volatile . . . . .	10.53	6.10	7.90	8.85	5.65	6.58	4.97	1.51
Fibre . . . . .	18.89	9.68	11.88	5.65	0.10	3.87	32.15	21.06
Nitrogen, total . . . . .	2.53	1.86	2.15	2.14	1.85	1.99	2.36	1.72
Nitrogen in fixed ether extract . . . . .	0.45	0.25	0.32	0.34	0.24	0.30	0.15	0.20
Alcohol extract . . . . .	11.86	8.31	9.44	8.05	7.19	7.66	6.30	4.00

and the following Table given by Richardson (U.S. Dept. Agric. Bur. Chem. Bull. 1887, 13, n, 206) shows the general composition of black and white pepper.

TABLE II.

	Black pepper.	White pepper.
Water . . . . .	80 - 110	8.0 - 11.0
Ash . . . . .	2.75 - 5.0	1.0 - 2.0
Volatile oil . . . . .	0.50 - 1.75	0.5 - 1.75
Piperine and resin . . . . .	7.0 - 8.0	7.0 - 8.0
Starch . . . . .	32.0 - 38.0	40.0 - 44.0
Crude fibre . . . . .	8.0 - 11.0	4.11 - 8.0
Albuminoids . . . . .	7.0 - 12.0	8.0 - 10.0

For routine chemical examination, the ash and the ash insoluble in hydrochloric acid should be first determined, the analyst being guided as to further work by the results of the microscopical examination.

If the total ash exceeds 5% in the case of black pepper or 2% in the case of white pepper, added mineral matter may be suspected and a more detailed analysis is required. The composition of the ash of black and white pepper has been examined by Udtgger (Arch. Hyg. 1886, 4, 183) and of black pepper by A. W. Blyth ("Foods, Their Composition and Analysis," 6th ed. 1909,

p. 495), but in the writer's opinion the white pepper may have been whitened with calcium phosphate. The results are shown in Table III.

TABLE III.—ASH OF PEPPER.

	Black pepper, %	White pepper, %
K <sub>2</sub> O . . . . .	24.4 - 34.7	6.13
Na <sub>2</sub> O . . . . .	1.5 - 6.5	0.79
CaO . . . . .	11.6 - 16.1	33.09
MgO . . . . .	3.3 - 13.0	10.59
Fe <sub>2</sub> O <sub>3</sub> . . . . .	0.3 - 2.2	2.04
MnO <sub>2</sub> . . . . .	0.19 - 0.8	0.55
. . . . .	8.5 - 1.1	3.005
. . . . .	4.0 - 9.6	3.50
. . . . .	5.4 - 8.5	0.72
Silica or sand . . . . .	1.5 - 6.5	2.05
. . . . .	14.0 - 20.0	10.96

The constituents to which the aroma of pepper are due are chavicine, piperine, piperidine, a volatile oil, and a resin. It was long believed that the pungency of pepper was due to piperine, a colourless, crystalline alkaloid, m.p. 128°. Piperine is soluble in ether and less soluble in alcohol, feebly basic, and optically inactive, although it is one of four isomeric compounds, being a piperidide of piperic acid. It is stated to be present to about 9% in black and

7% in white pepper, though the evidence is confusing and it is probable that the actual amount of piperine is lower than this in both varieties. This anomaly is due to the common method of determining the nitrogen in the ether soluble portion and calculating the whole of it as piperine, whereas allowance should be made for chavicine and other nitrogenous compounds. Piperine was first isolated in 1819 by Oersted, and its composition,  $C_{17}H_{19}NO_3$ , ascertained by Regnault. Babo and Keller (J. pr. Chem. 1857, [1], 72, 53) discovered that piperine could be hydrolysed to piperidine and piperic acid, and as a result Rugheimer (Ber. 1882, 15, 1390) effected a partial synthesis, but it was left to Ladenburg (*ibid.* 1885, 18, 2956, 3100) to complete its synthesis. Piperine is at first tasteless, but if ground with starch and left for several days the mixture acquires the intensely bitter taste of pepper. An alcoholic solution of piperine is similarly bitter but Ott and Zimmermann (Annalen, 1921, 425, 314) consider that this is due to the presence of traces of chavicine. Chavicine was first reported by Buchheim (Arch. exp. Path. Pharm. 1876, 5, 455) and Ott and his collaborators have confirmed his work. Chavicine is a resinous compound, more soluble in alcohol than piperine, but isomeric with the latter, being a piperidide of chavicine acid, which is isomeric with piperic acid." Chavicine may be extracted from black pepper by alcohol, the solvent removed, and the extract treated with ether until no further colour is removed. The ether solutions are shaken with 10% caustic alkali, washed with water, and the ether removed. The residue is steam-distilled to remove all essential oils, and then dissolved in ether and allowed to stand at 0° for several days to precipitate piperine. The crude resin is extracted with light petroleum, dissolved in alcohol, and decolorised with charcoal. After removal of the solvent the resin is left as a dark brown viscous liquid, which may be further purified by solution in benzene, the addition of stannic bromide and the precipitation of the additive compound by ether. The chavicine is regenerated by re-solution in benzene and precipitation by ether.

A. and R. Pictet (Helv. Chim. Acta, 1927, 10, 593) have isolated a liquid alkaloid from pepper, which they have identified as an optically active  $\beta$ -methylpyrrolidine, which forms  $\beta$ -methylpyrrolidine, with racemisation, on reduction with tin and hydrochloric acid. The alkaloid forms well-defined aurichloride, platinichloride, and picrate, all of which have sharp melting-points. Their work has not, however, been confirmed by Späth and Englaender (Ber. 1935, 68 [B], 2218), who also claim that piperidine is not present in pepper in the free state. It is not clear at the present time whether piperidides of piperic acid or chavicine acid are present in pepper.

Although piperine is said to be found only in the fruits and seeds of the piper species, H. Staudinger and H. Schneider and their collaborators (*ibid.* 1923, 56 [B], 699), have prepared the piperidides of 8-phenyl- $\beta$ -pentenoic acid, all of which possess a similar flavour, to piperine. C. Riecomanni

(Atti R. Acad. Lincei, 1924, 83, 145) has shown that piperidine is unnecessary for obtaining the pepper flavour which is possessed by 1:4-di-5-phenylid- $\beta$ -pentenoylpiperazine.

Amounts of oxalic acid varying from 0.45 to 3.39% have been reported to be present in pepper. The chief constituent of pepper is starch, which is about 63% in decorticated white pepper, 56% in white pepper and 34% in black pepper. The protein of pepper does not appear to have been investigated, but from the hard structure of the perisperm it would appear to be similar to that in the horny portion of cereal grains.

*Adulteration.*—It was reported in 1917 that pepper was still the most adulterated spice in Canada, 13.7% of the samples not being genuine. Wheat starch, rice starch, oat starch, corn meal, olive stones, coconut shell, sand, cayenne, calcium or magnesium carbonates, and pepper shells are the chief adulterants. The husk removed from white pepper in the course of manufacture is frequently added to both black and white peppers, being in the latter case bleached by chlorine or sulphur dioxide. If the fibre in a white pepper much exceeds 5% and microscopic examination shows the presence of the outer portions of the shell, the husk may be taken as roughly equal to the percentage of fibre less 5 multiplied by 3. For a more accurate determination, E. R. Smith, S. Alfend, and L. C. Mitchell (J. Assoc. Off. Agric. Chem. 1926, 9, 333) recommend the determination of the fibre,  $\beta$ -glucose and magnesium oxide contents of the pepper. The  $\beta$ -glucose value is obtained by direct acid hydrolysis of 2.5 g. of the pepper without previous treatment, heating for 2.5 hours with 200 ml. of water and 20 ml. of dilute hydrochloric acid under reflux, neutralising, and determining the dextrose on an aliquot portion by copper reduction. Their results are summarised in the following Table:

TABLE IV.

Origin.	No. of samples.	Crude fibre.	$\beta$ -glucose.	MgO.	MgO $\times$ crude fibre.	MgO $\times 100$ / $\beta$ -glucose.
Lampung . . .	*8	13.9	52.5	0.42	5.8	81
Allepl . . .	0	13.0	56.1	0.41	> 5.3	7.3
Tellicherry . . .	5	14.4	57.5	0.40	5.8	70
Singapore . . .	2	15.6	55.1	0.43	e.7	7.8
White and decorticated Shells . . .	4	4.1	77.9	0.16	0.7	21
" . . .	4	31.6	21.2	0.80	25.3	87.8
" . . .	—	24.4	29.3	0.64	15.6	21.9
" . . .	—	25.3	29.7	0.6%	16.2	21*
" . . .	—	30.0	21.1	0.79	23.7	37.4
Sittings . . .	3	18.3	12.8	—	—	—
" . . .	—	20.8	14.8	Z	—	—
" . . .	—	24.6	22.5	0.61	1.50	27.1

At one time ground olive stones (poivrette or pepperette) were a common adulterant. Under polarised light with the microscope they stand out brightly in the dark field and exhibit a reddish tinge. Most of the structural elements of pepper remain almost dark, but long pepper exhibits a bluish tinge. Campbell Brown

(Analyst, 1887, 12, 24) gives the analysis of three samples of ground olive stones. Probably the commonest adulterant is starch in some form or the other, and during the 1939-45 war mixtures of pepper, wheat flour, and cayenne were sold as pepper. Bice starch is not so readily detected as the larger starches and H. Wagner (Pharm. Weekblad, 1928, 65, 680) recommends a stain obtained by dissolving 0.5 g. carmine in 25 ml. of glycerol and 25 ml. of 4N. ammonia and filtering after some hours. The pepper, is soaked in this solution for about 7 hours and washed four times with water; rice starch is stained an intense violet colour, whilst the perisperm of the pepper remains unchanged; 2% of rice meal may be detected by this means.

Excessive proportions of mineral matters may be present, owing to the whole berries having been insufficiently cleansed from adherent earth, or to their having been coated with kaolin, french chalk, or similar material. The addition of chalk or magnesium carbonate to pepper may be readily observed by placing the sample on a microscope slide, mixing with chloral hydrate containing 1% dilute hydrochloric acid, and covering with a cover slip, pure pepper being used as a control. Bubbles of carbon dioxide form round the particles of carbonate and can be seen under the microscope or a strong lens.

The red berries of *Schinus molle*, when dried and roasted, appear somewhat similar to black pepper and are used for adulteration. When the berries are whole they may be detected by the naked eye on breaking the fruit. The drupes of *Schinus molle* show a lignified capsule of irregular stellate form. The lignified tissue is easily recognised under the microscope, or the pepper may be boiled with Fehling's solution, which is immediately reduced by the sugars (10%) present in *Schinus molle*.

**Microbiological Content and Action.**—J. W. Corran and S. H. Tidgar (J.S.C. 1.1933, 52, 149T) have shown that black pepper, so far from inhibiting fermentation by yeast, actually contains a yeast stimulant. J. Yesair, C. B. Williams, and L. B. Jensen (quoted by Jensen in "Microbiology of Meats," 2nd ed., Garrard Press, 1945, p. 345) have shown that black pepper may contain from 72,000-40,000,000 bacteria and from 500-1,300,000 moulds per g., white pepper from 7,000-3,000,000 bacteria and from 2,700-110,000 moulds per g., and decorticated white pepper 1,380,000 bacteria and 30,000 moulds per g.

**Standards.**—At the present time there is no legal standard for pepper in the United Kingdom.

Long Pepper is the unripe fruit of *Piper officinarum* Irtiq. C.D.C. which grows in the islands of the Malay Archipelago, or *Piper longum* Linn. (N.O. Piperaceae) which grows in Bengal, and the Philippine islands.

The fruit spike has the form of catkins from 2 to 6 cm. long and 4 to 8 mm. wide in the case of *P. officinarum*, that of *P. longum* being shorter (about 2 cm. long) and broader. It consists of numerous mintive berries disposed along and partly embedded in an elongated axis. It has an odour and flavour somewhat resembling ordinary pepper but weaker and less agreeable, the smell becoming decidedly objectionable on

warming. *P. longum* rarely comes on to the market. Most of the microscopic structure of long pepper is very similar to that of pepptr, but it contains more fibro-vascular bundles owing to the presence of the spike stalk; others are seen between the fruitlets. The stone cells have their longer axis parallel to the surface and not radiating from it as in pepper. The endocarp cells are not beaker shaped as in pepper, nor have they thickened radial walls, but are elongated. The starch grains, usually about 6/z, may be as large as 10/x, and are slightly larger than those of pepper; they are also found to a greater extent in the epiderm than in pepper.

It contains about the same amount of volatile oil and about half the amount of piperine present in ordinary pepper and as the fruit often trails on the ground the ash is liable to be high, owing to the inclusion of clay and sand from the adherent soil, for the removal of which no special steps are taken. The figures obtained on analysis by Campbell Brown (Analyst, 1887, 12, 68), and by Winton, Ogden, and Mitchell, and C. Arragon (*l.e.*), are as follows:

	Max., %.	Min., %.
Total ash . . . . .	9.61	5.08
Ash insoluble in HCl . . . . .	0.22	0.15
Ether extract non-volatile	7.7	4.90
Starch and matters convertible into sugar . . . . .	51.6	42.88
Fibre . . . . .	15.70	5.76
Nitrogen . . . . .	2.30	2.00
Alcohol extract . . . . .	8.67	
Starch by diastase . . . . .	39.55	

It contains about 1% of a light green, viscid volatile oil, with an odour similar to that of ginger, but tasting like pepper. It does not come into the retail market, and its chief use is in the pickling and canning trade, and, formerly, at all events, for the adulteration of black and white pepper (*q.v.*), for which purpose it may be bleached.

It has been used medicinally as a stimulant and carminative.

T. McL.

## PEPPERMINT, OILS OF (v. Vol. VIII, 6606).

**PEPSIN.** This enzyme, which is the principal proteolytic agent of the gastric juice of animals, fish, and birds, was discovered in 1836 by Schwann (Muller's Archiv. 1836, 90). It is produced by the "Hauptzellen" (peptic cells) of the gastric mucosa in its zymogen form (pepsinogen), which is converted into the active form by\* the hydrochloric acid elaborated by the parietal (oxyntic) cells (Carlson, Physiol. Rev. 1923, 3, 1). This change is autocatalytic under acid conditions (Herriott and Northrop, Science, 1936, 83, 469). The existence of pepsinogen was first suggested in 1874 by Ebstein and Grutzner (Pfliiger's Archiv. 1874, 8, 122) and it was first obtained from the gastric mucosa of pigs by Langley in 1882 (J. Physiol. 1880-82, 3, 246). It differs from pepsin in that it possesses no enzymic properties and is not destroyed by weak alkali at pH 8, whereas pepsin is inactivated under these conditions. Pig and cow pepsin and pepsinogen have been obtained crystalline by

Northrop and his colleagues (J. Gen. Physiol. 1930, 13, 739, 767; 1933, 16; 615; 1938, 21, 501; Science, 1929, 69, 580; 1936, 83, 469) and salmon pepsin by Norris and Elam (*ibid.* 1939, 90, 399; J. Biol. Chem. 1940, 134, 433). Crystalline pepsin appears to be a type of globulin and contains phosphorus and chlorine. Its molecular weight varies from 35,000 to 70,000, depending on the method of estimation, *e.g.*, the ultracentrifuge gives 35,500 (Philpot and Eriksson-Quensel, Nature, 1933, 132, 932). The isoelectric point is about pH 2.7 and the optimum pH 1.5-2.0, the pH of normal gastric juice.

In the alimentary tract pepsin is the first enzyme concerned in the hydrolysis of proteins. It attacks the peptide links, yielding proteoses and peptones, together with small amounts of amino-acids. Most proteins are susceptible to attack by pepsin, but notable exceptions are scleroproteins, *e.g.*, the fibroins and the keratins which are, in general, not hydrolysed.

The activity of pepsin preparations may be measured by the usual methods, *e.g.*, clotting of milk, formol titration, formation of non-protein nitrogen in protein solutions, viscosity changes of protein solutions (*see* Northrop, J. Gen. Physiol. 1933, 16, 41). A more recent method, which is very suitable, makes use of the digestion of haemoglobin by the enzyme, with the estimation of the tyrosine liberated (Anson, J. Gen. Physiol. 1938, 22, 79).

H. G. B.

**PERABRODIL.** Diethanolamine 3:5-diiodo-4-pyridone-N -acetate. "Diodone." Drug used for intravenous pyelography. B.P.C. Supp. III (*v.* SYNTHETIC DRUGS).

S. E.

**PERCAINE** (*v.* NUPEBCAINEOHYDROCHLORIDE, Vol. VIII, 6270").

S. E.

**PEREZONE.** *Pinitzahoic acid*, C<sub>16</sub>H<sub>20</sub>O<sub>3</sub>, 2-hydroxy-3-methyl-6-( $\alpha$ -dimethyl- $\beta$ -hexenyl) benzoquinone,

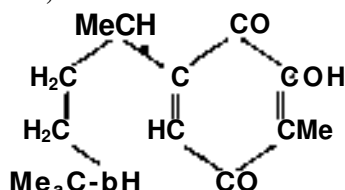

Perezone is obtained from *Radix perezise*, a purgative drug in native Mexican medicine derived from the plant *Trixis pitzahauac* (Fam. Compositae). The root when extracted with cold alcohol (Fichter *et al.*, Annalen, 1913, 395, 1) yields 5% of perezone, deep orange leaflets from alcohol, m.p. 104°C. (sublimes). It is not optically active in alcoholic solution but has  $[\alpha]_D^{20} -17^\circ$ . The optical rotation and the melting-point are depressed by sublimation, owing to facile racemisation. Remfry (J.C.S. 1913, 103, if 1076; *cf.* following reference) prepared anilidoperezone, dark violet needles, m.p. 135°C, and salts of the general formula, C<sub>15</sub>H<sub>19</sub>O<sub>3</sub>M. The structural formula of perezone stated above, proposed by Kögl and Boer (Rec. trav. chim. 1935, 54, 779) is based on the following reactions: the methyl and oxygen side chains are indicated

by oxidation of perezone with hydrogen peroxide to acetic acid and a nonenoic acid, and were shown to be in the *para* position to each other by distillation of perezone with zinc dust and oxidation of the product to give terephthalic acid. The location of the hydroxyl group is supported by its failure to form an internal condensation product. The carbon structure of the long side chain is revealed by the formation of acetone on oxidation, by its asymmetry and by the synthesis of the 2:6-dimethylheptanoic acid identical with the racemised acid from the oxidation of dihydroperezone. The position of the double bond in the long side chain is indicated by the formation of acetone peroxide when triacetylucoperezone is oxidised. Perezone has one active hydrogen atom (Zerewitinoff).

The antihemorrhagic activity of perezone has been studied by Giral (A. 1942, III, 702) who found a vitamin-K activity (*v.* Vol. VII, 87a, 89a) comparable with that of 2:5-dimethyl-1:4-benzoquinone.

J. N. G.

**PERFUMES, SYNTHETIC.** During the past three decades an increasing use has been made of synthetic chemicals in perfume mixtures. Although compounds differing widely in chemical properties can be employed to introduce similar odour sensations it is convenient to deal with these compounds as groups of chemical compounds rather than in divisions based on odour similarity.

ALCOHOLS.

*n*-Nonyl Alcohol has a sharp rose-like odour. It is prepared by reducing ethyl pelargonate with sodium and alcohol (G.P. 164294, 1903) or by reducing ethyl nonylenate (V. H. Harding and C. Weizmann, J.C.S. 1910, 97, 304). The alcohol has m.p. -5°C, b.p. 107.5°/15 mm.,  $n_D^{20}$  0.8279,  $n_D^{25}$  1.4382.

*n*-Decyl Alcohol possesses a sweet flower-like odour. It can be prepared by reducing ethyl caproate with sodium and alcohol (L. Bouveault and G. Blanc, G.P. 164294, 1903) or by hydrogenating methyl caproate (W. Schrauth *et al.*, Ber. 1931, 64 [B], 1318). *n*-Decyl alcohol has b.p. 120°/12 mm.,  $n_D^{20}$  0.8297,  $n_D^{25}$  1.4372.

Nerol is probably a mixture of *trans*-2:6-dimethyl- $\beta$ -octadien-8-ol and *cis*-2:6-dimethyl- $\beta$ -octadien-8-ol (J. L. Simonsen and L. N. Owen, "The Terpenes," 2nd ed., Cambridge University Press, 1947, Vol. I, p. 54). It possesses a delicate rose-like odour and is invaluable in preparing certain high-grade perfume mixtures. Nerol can be isolated from essential oils (H. von Soden and W. Treff, Ber. 1906, 39, 906) and synthetic methods depending upon the following are stated to be in use: (i) when linalool is acetylated a proportion of geranyl and neryl acetates is produced (O. Zeitschel, *ibid.* 1906, 39, 1780; G.P. 165894-5-6, 1903); (ii) reduction of citral by Ponnendorf's method (Z. angew. Chem. 1926, 39, 138; R. Sornet, Rev. Chim. Ind. 1930, 39, 98) leads to a mixture of geraniol and nerol; it has also been claimed that geraniol can be converted into nerol by heating with a metallic alcoholate (G.P. 462895,

1924); (iii) geraniol yields with halogen acids addition products which on treatment with alkali give a mixture of alcohols containing nerol (B.P. 127575, 1918). Nerol has b.p.  $125^{\circ}/25$  mm.,  $p_{15}^{\circ}$  0-8813.

Citronellol is most probably a mixture of 2:6-dimethyl-J<sup>2</sup>-octen-8-ol and 2:6-dimethyl-Ji-octen-8-ol (J. L. Simonsen and L. N. Owen, *op. cit.*, Vol. I, p. 36). The Z-form is present in geranium oil and the  $\wedge$ -modification is obtained by reducing suitable alcohols or aldehydes. The Z-form is much cheaper in price than the Z-form but is less highly esteemed by perfumers than the naturally occurring alcohol. Citronellol may be obtained by reducing geraniol with sodium in an inert solvent (G.P. 256716, 1911); by catalytic reduction of citral (R. Adams and B. S. Garvey, J. Amer. Chem. Soc. 1926, 48, 477; G.P. 298193, 1913); and by reducing citronellal (U.S.P. 1802468, 1931; A. Lewinsohn, Perf. and Essent. Oil Rec. 1923, 14, 360; B.P. 301577, 1927; H. Rupe and R. Rinderknecht, Helv. Chim. Acta, 1924, 7, 541; Amer. Chem. Abstr., 1922, 16, 2813). A process of synthesising 3:7-dimethyl-J<sup>1</sup>-octen-6-ol has been claimed to be economical starting from methylheptenol (G.P. 423544, 1924).

3:7-Dimethyloctan-1-ol, which has a rose-like odour, has been obtained as a reduction product of geraniol (R. Willstätter and E. W. Mayer, Ber. 1908, 41, 1479), citronellol (A. Haller and C. Martine, Compt. rend. 1905, 140, 1303), citral (G.P. 298193, 1913) and citronellal (H. Rupe and R. Rinderknecht, Helv. Chim. Acta, 1924, 7, 541). I\* has b.p.  $118^{\circ}/15$  mm.,  $p^4$  0-849.

Farnesol is a commonly occurring sesquiterpene alcohol found in small proportions chiefly in rather valuable blossom oils. The pure alcohol possesses a faint floral odour. It can be obtained from ambrette seed oil by saponification and isolation through the hydrogen phthalate (L. Ruzicka, Helv. Chim. Acta, 1923, 6, 497). Synthetically it is obtainable by treating nerolidol with acetic anhydride (G.P. 469555, 1923). Farnesol has b.p.  $145-146^{\circ}/12$  mm.,  $p$  0-885-0-898,  $w^{\circ}$  1-4877-1-4924,  $a_D^{\circ}$  0.

Nerolidol.—The d-form of nerolidol has been found in orange blossom oil and in Peru balsam oil from which it can be obtained by saponification (L. Ruzicka, Helv. Chim. Acta, 1923, 6, 492).  $\wedge$ -Nerolidol has been synthesised by condensing geranyl chloride with acetoacetic ester and treating the resulting ketone with acetylene and sodumide to give dehydro-tft-nerolidol which was reduced, with sodium and ether to dl-nerolidol (J&P. 213250, 1924; U.S.P. 1644546, 1927).

a-Terpeneol, which occurs widely in essential oils (d-, l-, and cK-forms) has an odour of lilac. The synthetic product, which is optically inactive and usually contains some l-terpeneol and terpinen-1-ol, is of the greatest importance in perfumery and the literature dealing with its preparation is very extensive. Terpeneol can be obtained directly from turpentine oil (a- and 0-pine) by treatment with suitable reagents (P. Barbier and V. Grignard, Compt. rend. 1907, 145, 1425; F. G. Germuth, Amer. J.

Pharm. 1927, 99, 402; G.P. 223795, 1907; U.S.P. 2060597, 1936; 2178349, 1939). The usual process involves conversion of the pinene into terpin hydrate and removal of the elements of water from the latter (H. Tatu, Technique Moderne, 1928, 20, 264; B.P. 153606, 1919; S. L. Malowan, Perf. and Essent. Oil Rec. 1933, 24, 81; U.S.P. 2088030, 1937). Processes have also been devised to isolate the terpeneol from the pine oil obtained by destructive distillation or by a steam solvent process, from pine wood (U.g.P. 1743403, 1930; 1961398, 1934; 2052742, 2052743, 1936).

Benzyl Alcohol, Ph-CH<sub>2</sub>-OH, has a mild pleasant aromatic odour and is widely used in the preparation of perfumes. The alcohol can be obtained by boiling benzaldehyde with soda lye (F. Ullmann, Enzyklopädie der technischen Chemie, 1928, 2, 2S3) or treating benzyl chloride with similar reagents (A. Lewinsohn, Chemical Products, 1939, 2, 14; G.P. 484662, 1926; U.S.P. 2221882, 1940). Benzyl alcohol has b.p.  $93^{\circ}/10$  mm.,  $p_{15}^{\circ}$  1-050,  $n_D^{20}$  1-5395.

j8-Phenylethyl alcohol, Ph-CH<sub>2</sub>-CH<sub>2</sub>-OH, which imparts the characteristic odour to rose water, is a most important perfumery chemical and, the literature dealing with its preparation is extensive. Of the routes available it appears to be most frequently prepared commercially by reducing ethyl phenylacetate (I. Herold, Dent. Parfümerie-Ztg. 1931, 17, 54; L. Bouveault and G. Blanc, Compt. rend. 1903, 136, 1676; C. S. Leonard, J. Amer. Chem. Soc. 1925, 47, 1774; M. H. Ittner, Chem. and Ind. 1942, 20, 139; B.P. 385625, 1930). The alcohol is obtainable by reducing the triglyceride of phenylacetic acid (G. Darzens, Compt. rend. 1937, 205, 684). Grignard (MSL1905, 141, 44) derived the alcohol by decomposing Ph-CH<sub>2</sub>-C<sub>2</sub>H<sub>5</sub>-O-MgBr, and this route was later re-investigated (e.g., F.P. 807632, 1937; U.S.P. 2058373, 1936; Chem. Zentr. 1935, n, 922). Phenylethyl alcohol can also be produced by the Frédel-Crafts method from benzene and ethylene oxide in the presence of suitable condensing agents (e.g., U.S.P. 2013710, 1935; 20209618, 2047396, 1936). For other methods reference should be made to G.P. S96523, 1932; B.P. 320424, 1928; J. von Braun and G. Kochendorfer, Ber. 1923, 56 [B], 2176; U.S.P. 2185141, 1937; G.P. 604861, 1924. Phenylethyl alcohol has b.p.  $104^{\circ}/12$  mm.,  $p^{16}$  1-0242,  $n_D^{\circ}$  1-532.

Cinnamyl Alcohol, Ph-CH:CH-CH<sub>2</sub>-OH, has a pleasant hyacinth-like odour. It can be obtained as a saponification product of storax (£. Lewinsohn, Perf. and Essent. Oil Rec. 1924, 15, 118) or by reducing cinnamaldehyde (G.P. 535954, 1924). Cinnamyl alcohol has m.p.  $33^{\circ}$ , b.p.  $258^{\circ}/760$  mm.,  $n_D^{20}$  1-5819,  $p^{15}$  1-02.

A Note on Carbinols.—Various carbinol derivatives are of value in perfumery and the following are perhaps the more well known: dimethylbenzylcarbinol (V. Grignard, Compt. rend. 1900, 130, 1322; M. Tiffeneau and R. Delange, *ibid.* 1903, 137, 675; A. Klages, Ber. 1904, 37, 1723; A. Reclaire, Deut. Parfümerie-Ztg. 1929, 15, 285; J. Salkind, Chem. Zentr. 1916, n, 384); dimethylphenylcarbinol (M. Tissier and Guignard, Compt. rend. 1901, 132,

1184) trichlorophenylmethylcarbinol and its acetate. (A. Lewinson, Riechstoffindustrie, 1935, 10, 121; A. A. Morton and J. R. Stevens, J. Amer. Chem. Soc. 1931, 53, 2244).

Phenylethyleneglycol,



has a mild gardenia-like odour and certain esters are stated to be valuable in perfumery (W. A. Poucher, Perfumes, Cosmetics, and Soaps, 1941, 1, 341). The preparation of the glycol and the diacetate have been described (Th. Zincke, Annalen, 1882, 216, 286; W. L. divans and L. H. Morgan, J. Amer. Chem. Soc. 1913, 35, 54; L. Palfray, S. Sabatay, and D. Sontag, Compt. rend. 1931, 193, 942; U.S.P. 1626398, 1927).

#### Ethers.

p-Cresyl Methyl Ether, which is a constituent of ylang-ylang and wallflower oils, can be prepared by methylating p-cresol with methyl sulphate under appropriate conditions (L. Herold, Deut. Parfumerie-Ztg. 1931, 17, 175). It has b.p. 175°,  $n_D^{20}$  1.0975.

Diphenyl-Ether, Ph-O-Ph, has a strong and penetrating odour of geranium and is widely used in soap perfumes. The ether is obtained by heating bromobenzene with potassium phenoxide in the presence of a copper catalyst (V. Ullmann and P. Sponagel, Ber. 1905, 38, 2211) or from chlorobenzene and dry potassium phenoxide in an autoclave (G.P. 269543, 1912; c. U.S.P. 1744961, 1930) or from sodium phenoxide and sodium benzene sulphate (U.S.P. 1372434, 1921). Under appropriate conditions diphenyl ether can be prepared from chlorobenzene and sodium hydroxide using phenol as a flux (U.S.P. 20987, 1933) and from phenol itself by heating with an activated silicate in an autoclave (G.P. 530736, W29). Methods of preparation have been reviewed by Murat (Parfumerie Moderne, 1922, 15, 51). Diphenyl ether has m.p. 28°, b.p. 259°.

Ethers of  $\beta$ -Naphthol.—The methyl ether ( $n_D^{20}$  1.072) (*nerolin*, *yara-yara*) can be obtained by refluxing methyl alcohol,  $\beta$ -naphthol and sulphuric acid (L. Gattermann, Annalen, 1888, 244, 72) or by treating a solution of the sodium salt of the phenol with methyl sulphate (R. Sornet, "La Technique Industrielle des Parfums Synthétique," Paris, 1923). The ethyl ether (m.p. 37-5°) (*bromelia*) has been prepared from ethyl alcohol, sulphuric acid, and  $\beta$ -naphthol (C. Liebermann, and A. Hagen, Ber. 1882, 15, 1428; W. A. Davis, J.C.S. 1900, 77, 35); by the interaction of  $\beta$ -naphthol and acid amides containing the group



(R-alkyl) (G.P. 189843, 1906; 224388, 1906) and from  $\beta$ -naphthol, sodium hydroxide, and ethyl sulphate (A. R. Cade, Chem. Met. Eng. 1923, 29, 320). The isobutyl ether of  $\beta$ -naphthol (m.p. 37-5°) (*fragarol*) can be prepared from isobutyl bromide and an alcoholic solution of the sodium salt of the phenol (F. Bodroux, Compt. rend. 1898, 126, 841; A. B. Wang, J. Chinese

Chem. Soc. 1933, 1, 60). The methyl and ethyl ethers have a neroli-like odour and the isobutyl ether a delicate fruity odour.

#### ALDEHYDES.

n-Heptaldehyde (cenanthol),  $\text{C}_6\text{H}_{13}\text{-CHO}$ , can be obtained, together with undecylenic acid, by distilling castor oil (F. Krafft, Ber. 1877, 10, 2034; 1880, 13, 1413; 1888, 21, 2733; U.S.P. 1889348, 1932) and rupture of the ricinoleic acid is facilitated by introduction of a stream of air (G.P. 167137, 1904) or by heating the oil in a thinly extended form (U.S.P. 1697337, 1929). The aldehyde may also be prepared by pyrogenetic decomposition of methyl ricinoleate (P. S. Panyutin, Amer. Chem. Abstr. 1928, 22, 3392; S. S. Nametkin and R. Y. Shagalova, *ibid.* 1942, 36, 3781). Heptaldehyde has b.p. 152-8°,  $n_D^{20}$  0.8216,  $n_D^{25}$  1.4257, *semicarbazone* m.p. 109°, and possesses a sharp, persistent, fruity odour so that it is rarely used in perfume mixtures, but it is an extremely important starting material for various perfumery and flavouring materials such as methyl heptylcarboxylate and  $\gamma$ -n-amylobutyrolactone.

n-Octaldehyde,  $\text{C}_7\text{H}_{15}\text{-CHO}$  (detected in lemon and lemongrass oils), has a sharp lemon-odour, which at the same time resembles that of heptaldehyde, and can be used in traces in perfume mixtures. The aldehyde can be obtained by passing caprylic acid and formic acid over catalysts at elevated temperatures (P. Sabatier and A. Mailhe, Compt. rend. 1912, 154, 563) or on similar treatment from octyl alcohol (R. H. Pickard and J. Kenyon, J.C.S. 1911, 99, 56). It has been obtained synthetically by various routes from heptaldehyde (L. Bouveault and A. Wahl, Compt. rend. 1902, 134, 1228; I. J. Rinkes, Rec. trav. chim. 1926, 45, 820). Technically it is obtained from coconut oil; the oil is saponified and esterified with methyl alcohol (the methyl w-caproate obtained by fractionation is reduced with sodium and alcohol to n-octyl alcohol which is oxidised with dichromate to the aldehyde (A. Wagner, "Die Aldehyde," Leipzig, 1930, III, p. 413). n-Octaldehyde (caprylic aldehyde) has b.p. 237°,  $n_D^{20}$  1.4285, *semicarbazone* m.p. 101°.

n-Nonaldehyde,  $\text{C}_8\text{H}_{17}\text{-CHO}$ , has a rose- and tangerine-like odour and is used in various perfume mixtures. The aldehyde can be prepared by vacuum distillation of a mixture of the barium salts of formic and pelargonic acids (G.P. 126736, 1900) and by decomposition of oleic acid ozonide (G.P. 321567, 1918; 324663, 1916; S. Isikawa and A. Miyata, Amer. Chem. Abstr. 1940, 34, 981). Technically it is prepared by oxidation of n-nonyl alcohol bypassing vapour of the alcohol at 3-5 mm. over a copper catalyst (A. Lewinsohn, Perf. and Essent. Oil Rec. 1924, 15, 12) or by using oxidising agents such as chromic acid or copper oxide (A. Wagner, *op. cit.*, p. 153). The aldehyde can be prepared directly from w-nonoic acid by reduction, using manganous oxide catalyst (R. Shagalova, Amer. Chem. Abstr. 1936, 30, 1026). The aldehyde has b.p. 190-192°,  $n_D^{20}$  1.4277,  $n_D^{25}$  1.4245, *semicarbazone* m.p. 100°.

n-Decaldehyde,  $C_9H_{19}\cdot CHO$ , has a spicy, orange-like odour. It can be prepared by the general methods given above and by the action of diethylformamide on the Grignard compound obtained from magnesium and w-nonyl chloride (L. Bouveault, Bull. Soc. chim. 1904, [iii], 31, 1326). Bagard (*ibid.* 1907, [iv], 1, 308, 356) showed that the aldehyde was obtained on heating  $\alpha$ -hydroxyundecic acid. Decaldehyde can be obtained in high yield from the oil distilled from the green parts of the coriander plant (E. Ya. Bryusova, R. Yu. ShagaloWa, and N. Novikova, Amer. Chem. Abstr. 1942, 36, 3781). The aldehyde has b.p. 208-209°,  $p^{16}$  0-828, wjj 1-4298, *semicarbazone* m.p. 102°.

n-Undecaldehyde,  $C_{10}H_{21}\cdot CHO$ , has a tenacious somewhat rose-like odour. It can be prepared by the general methods outlined above, although technically it is usually prepared by the method of Blaise and Guerin (Bull. Soc. chim. 1903, [iii], 29, 1202). Details of the larger scale preparation of this aldehyde have been given by Lewinsohn (Perf. and Essent. Oil Rec. 1924, 15, 79), and Davies and Hodgson (J.S.C. 1943, 62, 128) have recently investigated the method. The aldehyde has b.p. 116-117°/18 mm.,  $p^f$  0-8251, rig 1-4322, *semicarbazone* m.p. 103°.

n-Dodecaldehyde,  $C_{11}H_{23}\cdot CHO$  (lauric aldehyde), has been detected in the oil of *Abies pectinata* and has a fatty pungent odour which in dilute solution resembles somewhat that of the wild violet. The aldehyde can be obtained by heating a mixture of the barium salts of formic and lauric acids (F. Krafft, Ber. 1880, 13, 1413); by passing a mixture of the vapours of the acids over a manganous oxide-catalyst at elevated temperatures (S. S. Nametkin and O. M. Khol'mer, Amer. Chem. Abstr. 1942, 36, 3629), or by reaction between calcium laurate and formaldehyde in the presence of steam (U.S.P. 2145801, 1939) and by treating lauric acid with hydrogen at elevated temperatures in the presence of a mild hydrogenation catalyst (U.S.P. 2105540, 1938). Dodecaldehyde can be prepared from lauryl alcohol by oxidation with chromic acid (E. Blaise and G. Guerin, Bull. Soc. chim. 1903, [iii], 29, 1117, 1202); by catalytic oxidation (C. Moureu and G. Mignonac, Compt. rend. 1920, 170, 258; 1920, 171, 652; R. R. Davies and H. H. Hodgson, J.C.S. 1943, 282) or by catalytic dehydrogenation (A. Halasz, Amer. Chem. Abstr. 1940, 34, 1970). The aldehyde is a white, waxy, solid, m.p. 43-44°, b.p. 121°/10 mm., *semicarbazone* m.p. 101-5-102-5°.

#### Methyl-n-nonylactaldehyde,



has a persistent odour resembling that of a lemon-orange-ambergris mixture. The aldehyde is usually prepared by saponifying and distilling *in vacuo* the glycidic ester prepared by condensing methyl nonyl ketone with ethyl monochloroacetate (G. Darzens, F.P. 337175, 1903; cf. E. K. Smofyaninova, Amer. Chem. Abstr. 1942, 36, 3782). Sommelet (Bull. Soc. chim. 1907, [iv], 1, 408) prepared the aldehyde by heating 1-ethoxy-2-methylundecan-2-ol with formic acid. Methyl-n-nonylactaldehyde has

b.p. 114°/10 mm.,  $n_D$  1-4320-1-4450,  $p$  0-829, *semicarbazone* m.p. 85°.

*Higher Aldehydes.*—Attention has been drawn (Schimmel's Report, 1927, p. 132; 1928, p. 108) to the regrettable use of misleading trade names, to describe mixtures of lactones and esters (*e.g.*, so-called aldehydes  $C_{14}$  to  $t_{31}$ ).

Hydroxycitronellal was introduced into perfumery as early as 1905, although a method of preparation had not then been published, and it is still widely used. It can be prepared by the action of sulphuric acid on citronellal-bisulphite, -cyanohydrin, or -enolacrylate (A. Verley, Bull. Soc. chim. 1928, [iv], 43, 848; H. Schmidt, Schimmers Report, 1938, p. 124; L. M. Labaune, Revue des Marques Parfums de France, 1939, 17, 82; U.S.P. 2235840, 1941). It is claimed that a 30% yield of hydroxycitronellal is obtainable by the action of 7-40% sodium hydroxide solution on dry citronellal-bisulphite (S. S. Nametkin and O. M. Khol'mer, Amer. Chem. Abstr. 1942, 36, 3782). Improved yields are claimed (U.S.P. 2306332, 1942) by the action of hydrochloric acid on citronellal-hydrosulphonic acid. Hydroxycitronellal has b.p. 116°/5 mm.,  $p^{15}$  0-931.

Benzaldehyde is the main constituent (98-99%) of the essential oils of bitter almonds, peach kernels, and apricot kernels. Synthetically it has been prepared by numerous methods. Commercially, the aldehyde is derived from toluene, usually through the intermediate side-chain halogen derivatives or by direct oxidation (J. McLang, Chem. Trade J. 1926, 79, 191, 307; G.P. 82927, 1894; M. P. Ger, Amer. Chem. Abstr. 1936, 30, 3838; G.P. 101221, 1897; K. Kakutani and N. Yamaguchi, Amer. Chem. Abstr. 1929, 23, 3217; A. P. Kreshkov, *ibid.* 1941, 35, 1415; G.P. 347583, 1917; U.S.P. 2199585, 1940). Other processes involve passing benzoic acid or phthalic acid and carbon monoxide over an iron catalyst at 400° (G.P. 539756, 1926; U.S.P. 2018350, 1935) and treating benzene with carbon monoxide under pressure using an aluminium chloride catalyst (U.S.P. 1989700, 1933). Benzaldehyde has m.p. -26°, k.p. 179°/751 mm.,  $p^B$  1-0504.

p-Tolualdehyde has a powerful odour resembling bitter almond oil and black pepper oil. It can be prepared by oxidising *p*-xylene (E. Bornemann, Ber. 1884, 17, 1467; H. D. Law and F. M. Perkin, J.C.S. 1907, 91, 262; G.P. 101221, 1897); from toluene and carbon monoxide (L. Gattermann and J. A. Koch, Ber. 1897, 30, 1623; G.P. 281212, 1913) and from xylyl bromide on treatment with a solution of hexamethylene tetramine (G.P. 268786, 1913). p-Tolualdehyde has b.p. 98-100°/20 mm.,  $n_D^{20}$  1-5484,  $p''$  1-072, *semicarbazone* m.p. 219-220°.

Phenylacetaldehyde,  $Ph\cdot CH_2\cdot CHO$ , and its dimethylacetal are widely employed in perfumery. Numerous methods of preparation have been utilised. The aldehyde can be obtained on a technical scale by oxidising phenylethyl alcohol with chromic acid (A. Wagner, *op. cit.*, 1929, II, p. 570) or by catalytic methods (A. R. Guseva, Amer. Chem. Abstr. 1942, 36, 3794). When a mineral or suitable organic acid is added to an aqueous solution of the sodium



salt of phenylglycidic acid, carbon dioxide is evolved and phenylacetaldehyde is obtainable on steam-distillation (E. Erlenmeyer and A. Lipp, *Annalen*, 1883, **219**, 182; G.P. 107228, 1898; 107229, 1898; W. Dieckmann, *Ber.* 1910, 43, 1036; B.P. 371\*013, 1931). Sabatier and Mailhe (*Compt. rend.* 1914, **158**, 985) prepared the aldehyde by passing the vapour of phenylacetic acid in the presence of formic acid over a manganous oxide catalyst at 300-360° and methods of producing the aldehyde by catalytic reduction of phenylacetic acid have also been investigated (P. P. Shorygin *et al.*, *Amer. Chem. Abstr.* 1942, 36, 3794). Rosenmund and Zetzsche (*Ber.* 1921, 54 [B], 437) obtained an 80% yield of phenylacetaldehyde by hydrogenating a solution of the acid chloride of phenylacetic acid in toluene using a palladium-barium sulphate catalyst. Grignard and Escourrou (*Compt. rend.* 1925, **180**, 1884) by hydrogenating benzyl cyanide, using a platinum oxide catalyst, obtained phenylethanalimine which was hydrolysed with potassium hydroxide solution to ammonia and phenylacetaldehyde (*cf.* H. Stephens, *J.C.S.* 1925, **127**, 1874; 2. Herold, *Deut. Parfümerie-Ztg.* 1931, 17, 246). Other processes have been described by Langheld (G.P. 226226, 1909) and Kodama (*Amer. Chem. Abstr.* 1922, 16, 106). Phenylacetaldehyde has b.p. 88°/18 mm.,  $n_D^{20}$ , 1.5255,  $n_D^{18}$  1.0272.

p-Methoxyphenylacetaldehyde has a pungent odour resembling hawthorn blossom. It can be obtained by oxidising p-methoxystyrene with mercuric oxide and iodine (M. Tiffeneau, *Ann. Chim. Phys.* 1907, [viii], 20, 350; C. Mannich and W. Jacobsohn, *Ber.* 1910, 43, 195) and by the oxidation of methylchavicol with ozone in the presence of benzene and water (*cf.* C. Hajries and H. Adams, *ibid.* 1916, **49**, 1032). p-Methoxyphenylacetaldehyde (homonaldehyde) has K<sub>p</sub> 117-119°/9 mm.,  $n_D^{20}$  1.5359,  $n_D^{18}$  1.096, semicarbazone m.p. 175-176°.

p-Methylphenylacetaldehyde has a pungent odour resembling that of phenylacetaldehyde. It can be prepared by various methods (K. Auwers, *ibid.* 1906, 39, 3761; K. Kling, *Chem. Zentr.* 1908, 1, 951; E. Spath, *Ber.* 1914, 47, 767; *Monatsh.* 1915, 36, 9), but is probably most readily obtained by Darzen's method from p-methylbenzaldehyde (G.P. 591452, 1930). p-Methylphenylacetaldehyde has m.p. ca. 40°, b.p. 96°/10 mm., semicarbazone, m.p. 208°.

Vanillin (4-hydroxy-3-methoxybenzaldehyde), present to the extent of 1.5-2.5% in vanilla pods, is widely used in perfumery, confectionery, and foodstuffs. Vanillin was first produced synthetically in bulk by oxidising coniferyl alcohol (G.P. 576, 1877). In 1875 Reimer (*Ber.* 1876, 9, 423) showed that the aldehyde could be prepared by heating guaiacol, chloroform, and aqueous sodium hydroxide. Methods have been based upon the interaction of guaiacol with formaldehyde (G.P. 105798, 1898; B.P. 161679, 1920; J. McLang, *Chem. Trade J.* 1926, 79, 35). Guaiacyl trichloromethylcarbinol gives vanillin on saponification and oxidation (B.P. 219676, 1923). Vanillin can be prepared by methylation of protocatechuic aldehyde with a methyl halide under suit-

able conditions (G.P. 63007, 1890) or methyl sulphate (G.P. 122851, 1900). The most widely used method of preparation is still that from oil of cloves, which contains 75-90% of eugenol, via isoeugenol. Detailed processes have been given by a number of authors including Wagner (*op. cit.*, 1930, III-IV, p. 940); McLang (*Chem. Trade J.* 1925, 77, 3) and Herold (*Deut. Parfümerie-Ztg.* 1936, **22**, 35, 49, 67, 84). Acetyltiroeugenol is oxidised with a sodium dichromate-sulphuric acid mixture in the presence of sulphanic acid or p-aminobenzoic acid (Swiss P. 89053, 91088, 1919) to acetylvanillin, which is converted into the bisulphite compound, the acetyl group removed by boiling with water, and the liquor, treated with a calculated quantity of sulphuric acid, heated to remove sulphur dioxide, and the vanillin allowed to crystallise. Other methods depend upon the oxidation of alkali isoeugenoxides with nitrobenzene (B.P. 285451, 1927; 417072, 1933; 529134, 1939; G.P. 578037, 1931; 580981, 1932) or oxidising isoeugenol itself with air containing ozone (G.P. 97620, 1895). Processes for converting eugenol into isoeugenol (B.P. 285156, 285551, 1926; F.P. 326775, 1902) do not appear to have proved successful commercially up to the present. Methods have subsequently been developed for producing vanillin from lignin-containing materials (B.P. 319747, 1928; F. Leger and H. Hibbert, *J. Amer. Chem. Soc.* 1938, 60, 565; R. H. J. Creighton, J. L. McCarthy and H. Hibbert, *ibid.* 1941, 63, 312, 3049; K. Freudenberg, W. Lautsch, and K. Engler, *Ber.* 1940, 73 [B], 167; I. A. Pearl, *J. Amer. Chem. Soc.* 1942, 64, 1429). Vanillin has m.p. 81-82°, b.p. 170°/15 mm.

Ethylvanillin (4-hydroxy-3-ethoxybenzaldehyde) has an odour three to four times as intense as that of vanillin itself. It can be prepared from pyrocatechol monoethyl ether using the Reimer-Tiemann method (#P. 90395, 1894); by acylating protocatechuic aldehyde (G.P. 81071, 1894) and by various processes from safrole or wosafrole (B.P. 285156, 1926; 285451, 290649, 309929, 1927; 317381, 1928; G.P. 505404, 657547, 562007-8, 1925). Other methods involve the oxidation of 4-hydroxy-3-ethoxyphenylglycollic acid or of o-(3-ethoxy-4-hydroxyphenyl)-trichloroethanol (B.P. 445263, 1933; 453482, 1935; Dutch P. 41184, 1935) and of 1-hydroxy-2-ethoxy-4-methylbenzene (N. I. Wolinkin and P. J. Loschakow, *Chem. Zentr.* 1938, n, 1861). Ethylvanillin has m.p. 77-5°.

Anisaldehyde (p-methoxybenzaldehyde), has an odour resembling that of blossoming hawthorn and is a widely used constituent of perfume mixtures. It can be prepared (J. McLang, *Chem. Trade J.* 1926, 79, 190; I. Herold, *Deut. Parfümerie-Ztg.* 1931, 17, 175; H. Hunger, *Seifensztg.* 1937, 64, 476) by oxidising anethole with chromic acid, preferably in the presence of sulphanic acid; with ozonised air (G.P. 97620, 1895) or by electrolytic oxidation (F. Fichter and A. Christen, *Helv. Chim. Acta*, 1925, 8, 333; *cf.* E. Briner, H. von Tschärner, and H. Paillard, *ibid.* 1925, 8, 406). Alternatively the aldehyde can be prepared by oxidising p-cresyl methyl ether. Anisaldehyde is obtainable from anisole by the Gattermann

method (L. E. Hinkel, E. E. Ayling, and J. H. Beynon, J.G.S. 1935, 674; 1936, 184; E. L. Niedzielski and F. F. Nord, J. Amer. Chem. Soc. 1941, 68, 1462; R. Adams and E. Montgomery, *ibid.* 1924, 46, 1518). The aldehyde can be produced by methylating *j*-hydroxybenzaldehyde. Anisaldehyde has m.p. 0°, b.p. 248°/760 mm.,  $n_D^{20}$  1.574,  $\rho_4^{20}$  1.1228.

Cinnamaldehyde, PhCH:CHCHO, is the main constituent of cinnamon and cassia oils and is readily isolated therefrom by the usual bisulphite method. Synthetically the aldehyde is derived by condensing benzaldehyde with acetaldehyde (G. Ghazel, La Revue des Produits Chimiques, 1919, 22, 177). Other methods have been described by Bert and Annequin (Compt. rend. 1931, 192, 1315). Cinnamaldehyde has m.p. -7.5°, b.p. 130°/20 mm.,  $n_D^{20}$  1.6195,  $\rho_4^{20}$  1.105.

#### Dihydrocinnamaldehyde,



has a strong hyacinth-like odour. It can be prepared by reducing cinnamaldehyde dimethylacetal with sodium and alcohol (E. Fischer and E. Hoffa, Ber. 1898, 31, 1992) or by passing a solution of cinnamaldehyde in propanol over an aluminium catalyst at 330° (P. E. Weston and H. Adkins, J. Amer. Chem. Soc. 1929, 51, 2589) or by reducing cinnamaldehyde in alkaline solution with activated aluminium amalgam (Chem. Zentr. 1935, n, 3011). It has b.p. 104-105°/13 mm.,  $p^{20}$  1-018, *semicarbazone* m.p. 128°.

#### *a*-n-Amylcinnamaldehyde,



has a jasmine-like odour. It is prepared by condensing heptaldehyde with benzaldehyde (B. N. Rutowski and A. I. Korolew, J. pr. Chem. 1928, [ii], 119, 272; A. Rosenthal, Deut. Parfümerie-Ztg. 1931, 17, 3; TVI Backès, Bull. Soc. chim. 1942, [v], 9, 63) and has b.p. 140°/5 mm.,  $n_D^{20}$  1.5552,  $\rho_4^{20}$  0.9718. Various other aldehydes prepared from heptaldehyde and substituted benzaldehydes have been found to possess little perfumery value (A. Weizmann, J. Amer. Chem. Soc. 1944, 66, 310).

#### Cyclamen Aldehyde,



has a powerful blossom-odour resembling that of freshly cut cyclamen, lily, and lily of the valley flowers. The discoverers of this aldehyde, Knorr and Weissenbom (U.S.P. 1844013, 1932) condensed cuminaldehyde with propionaldehyde to give *^i*-isopropyl-*a*-methylcinnamaldehyde, which was reduced with hydrogen in the presence of a nickel catalyst to cyclamen aldehyde (*p*-isopropyl-*a*-methyl-dihydrocinnamaldehyde). Poizat (U.S.P. 2242322, 1941) prepared the aldehyde by treating diethyl methylmalonate with cumyl chloride. After saponification, the cuminylmethylmalonic acid was heated at 185° to give carbon dioxide with *p*-isopropyl-*a*-methyl-dihydrocinnamic acid, and the latter was converted into cyclamen aldehyde by passing a mixture of the vapours of this acid and formic acid over a manganese dioxide-pumice catalyst

at 360°. Cyclamen aldehyde has b.p. 115°/5 mm.,  $\rho_4^{20}$  0.951.

#### Heliotropin (piperonal),

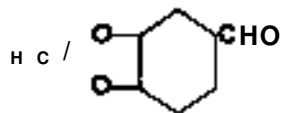

is one of the most important of synthetic perfumery chemicals. It is obtained by oxidising isosafrole with potassium dichromate and sulphuric acid (C. Ciamician and P. Silber, Ber. 1890, 23, 1159) preferably in the presence of sulphanic acid (G.P. 207702, 1905) or *^i*-aminobenzoic acid or *^i*-aminobenzaldehyde (Swiss P. 91087, 91270, 1919). The optimum temperature of reaction is claimed to be 46-48° (N. Hirao, Amer. Chem. Abstr., 1927, 21, 2675, 2676). IsoSafrol can be oxidised directly with ozonised air (G.P. 97620, 1895; J. McLang, Chem. Trade. J. 1926, 79, 359). Heliotropin can be obtained synthetically by treating protocatechuic aldehyde with methylene iodide (R. Wegscheider, Monatsh, 1893, 14, 388) or methylene sulphate (W. Baker, J.C.S. 1931, 1765). It has m.p. 35-36°, b.p. 263°.

#### KETONES.

Methyl *n*-Amyl Ketone, CH<sub>3</sub>-CO-C<sub>6</sub>H<sub>11</sub>, is sometimes included in carnation mixtures. The most convenient method of preparation appears to be that described by Johnson and Hager (Organic Syntheses, 1927, 7, 60) from ethyl *n*-butylacetoacetate. The ketone has b.p. 150°/760 mm.,  $\rho_4^{20}$  0.8366.

Ethyl *n*-Amyl Ketone, C<sub>8</sub>H<sub>17</sub>-CO-C<sub>2</sub>H<sub>5</sub>, occurs naturally in French lavender oil to which it imparts a particular freshness. The ketone can be prepared from caprilidjue-2 (A. Behal, Ann. Chim. Phys. 1888, [vi], 15, 275; A. Desgrez, *ibid.* 1894, [vii], 3, 239); from the ethyl ester of the corresponding *^i*-ketonic acid (L. Bouveault and R. Locquin, Bull. Soc. chim. 1904, [iii], 31, 1158) or by oxidising ethyl-*n*-amylcarbinol (Chem. Zentr. 1912, i, 1717). The ketone has b.p. 169-170°/738 mm.,  $\rho_4^{20}$  0.8502, *r*% 1-4156, *semicarbazone*, m.p. 115-116°.

Acetophenone, PhCO-*i*, which has been detected in the essential oil steam distilled from gum labdanum (H. Masson, Compt. rend. 1912, 154, 517), can be prepared synthetically by the general organic chemical methods. Special economical processes have been evolved for large-scale production, *e.g.*, (i) oxidation of ethylbenzene with air at elevated temperatures in the presence of a suitable catalyst (U.S.P. 1813606, 1931); (ii) passing the mixed vapours of phthalic anhydride and acetic acid through a tube containing manganous oxide at 350-400° (U.S.P. 1916741, 1931); (iii) heating a mixture of acetic anhydride (or acetic acid) with benzene and aluminium chloride and using iron, aluminium, or zinc as halogen carriers (U.S.P. 1999538, 1935; G.P. 646702, 1933). Acetophenone, which is a soporific, has m.p. 2-5°, b.p. 202°/750 mm., 94-95°/20 mm.,  $\rho_4^{20}$  1.53418.

*p*-Methoxyacetophenone (CrotopojO has an intense odour of hawthorn blossom and is especially useful in soap perfumes or in cases

when anisaldehyde may be unsuitable. It can be obtained by the action of acetyl chloride on anisole in the presence of aluminium chloride (F. Straus, *Annalen*, 1910, 374, 139). Bougault (*Compt. rend.* 1901, 132, 782) obtained the ketone by oxidising  $\alpha$ -methoxyhydratropic acid or the bisulphite compound of  $\alpha$ -methoxyhydratropaldehyde.  $p$ -Methoxyacetophenone has m.p. 37°, b.p. 152-154°/26 mm., *semicarbazone* m.p. 200°.

$p$ -isoPropylacetophenone has an odour resembling orris. It can be prepared by the Friedel-Crafts method from acetyl chloride and cumene, and has b.p. 252-254°/756 mm.,  $p^{16}$  0-9765 (O. Widman, *Ber.* 1888, 21, 2225).

Benzylacetone,  $\text{PhCH}_2\text{CH}_2\text{COMe}$ , has a jasmine-like odour. The ketone has been prepared (i) by saponifying  $\beta$ -benzylacetylpyruvic ester (A. Kötze and E. Lemmer, *J. pr. Chem.* 1914, [ii], 90, 389); (ii) by reducing benzylideneacetone with sodium amalgam (C. Harries and G. Eschenbach, *Ber.* 1896, 29, 383); or (iii) by heating ethyl benzylacetate with water in a sealed tube (H. Meerwein, *Annalen*, 1913, 398, 249). Benzylacetone has b.p. 115°/13 mm.,  $p^f$  0-9849,  $n_D^{20}$  1-511, *semicarbazone* m.p. 142°.

Benzylideneacetone,  $\text{Ph}\cdot\text{CH}:\text{CH}\cdot\text{CO}\cdot\text{CH}_3$ , has a tenacious odour resembling that of sweet pea. The compound is most easily produced by condensing acetone with benzaldehyde in the presence of sodium hydroxide solution (N. L. Drake and P. Allen, Jr., *Organic Syntheses*, 1941, Coll. Vol. 1, 77; A. Lewinsohn, *Perf. and Essent. Oil Rec.* 1924, 15, 118). Benzylideneacetone can cause severe skin irritation; it has m.p. 42°, b.p. 151-153°/28 mm.,  $n_D^{20}$  1-511, *semicarbazone* m.p. 185°.

Benzoylacetone,  $\text{Ph}\cdot\text{CO}\cdot\text{CH}_2\cdot\text{CO}\cdot\text{Me}$ , which has a fragrant balsamic odour, is widely used in perfume mixtures. The ketone can be obtained: (i) by hydrolysis of ethyl benzoylacetate (E. Fischer and K. Kuzel, *Ber.* 1883, 16, 2239), (ii) by condensing acetophenone and ethyl acetate in the presence of sodium ethoxide (C. Becher and L. Claisen, *Ber.* 1887, 20, 2180), or (iii) from ethyl benzoate and acetone using sodamide as condensing agent (L. Claisen, *ibid.* 1905, 38, 695). Benzoylacetone has m.p. 61°.

The ionones (*v.* Vol. VIII, 24c, d; 25a, c).—Ionone is available commercially as  $\alpha$ -ionone ( $\alpha$ -cyclohexylideneacetone),  $\beta$ -ionone ( $\beta$ -cyclohexylideneacetone) and ionone 100% (a mixture of the  $\alpha$ - and  $\beta$ -forms). These products are widely used in perfumery because of their odour of violets. In attempts to synthesise ionone, to which the incorrect empirical formula  $\text{C}_{13}\text{H}_{20}\text{O}$  had been assigned, Tiemann and Krieger (*ibid.* 1893, 26, 2675, 2692) obtained  $\alpha$ -ionone by condensing citral and acetone in the presence of calcium hydroxide. This acyclic ketone was converted into a mixture of the isomeric ketones,  $\alpha$ - and  $\beta$ -ionone, by heating with dilute acid and glycerol (F. Tiemann and P. Krieger, *ibid.* 1898, 31, 808, 867; G.P. 73089, 75120, 1893). Owing to the great importance of these ketones in perfumery, extensive investigation followed their discovery and can be grouped under several headings: (i) manufacture of  $\alpha$ -ionone (*see, e.g.,* G.P. 127661, 1900; 147839, 1901; W. Stiehl,

*J. pr. Chem.* 1898, [ii], 58, 79, 84, 80; O. Doebner, *Ber.* 1898, 31, 1888; H. Hibbert and L. T. Gannon, *J. Amer. Chem. Soc.* 1924, 46, 123), (ii) cyclisation of  $\alpha$ -ionone and control of the proportion of  $\alpha$ - and  $\beta$ -ionone in the product (*see, e.g.,* F. Tiemann, *Ber.* 1898, 31, 868; G.P. 129027, 1900; 133563, 138100, 157647, 1901; 164366, 172653, 1904), (iii) separation of  $\alpha$ - and  $\beta$ -ionone (*see, e.g.,* G.P. 106512, 1898; F. Tiemann, *Ber.* 1898, 31, 874, 1737). Lewinson (*Ferf. and Essent. Oil Rec.* 1923, 14, 259) has described a modern technical method of preparing the ionones from lemongrass oil. The preparation of  $\alpha$ - and  $\beta$ -ionone from  $\alpha$ - and  $\beta$ -cyclohexylideneacetone has also been the subject of extensive investigation (F. Tiemann, *Ber.* 1900, 33, 3719; G.P. 75062, 1893; 123747, 1900; 133758, 139957, 1901; 138141, 1902). Commercial ionone (100%) has the following constants (approximate)  $p^{16}$  0-935-0-940,  $n_D^{20}$  1-5035-1-5070,  $n_D^{20}$   $\pm$  0°;  $\alpha$ -ionone, b.p. 124-128°/12 mm.  $n_D^{20}$  1-4990,  $p^{16}$  0-934, *semicarbazone* m.p. 148-149°;  $\beta$ -ionone, b.p. 134-135°/12 mm.,  $p^{16}$  0-949,  $n_D^{20}$  1-5198, *semicarbazone* m.p. 148-149°.

Methylionones have a characteristic violet odour and are widely used in perfumery. The commercial mixtures of methylionones are prepared from citral and methyl ethyl ketone using processes similar to those employed for preparing the ionones (G.P. 75120, 1893; 127424, 1901; 133758, 1901; G. W. Pope and M. T. Bogert, *J. Org. Chem.* 1937, 2, 276). The four isomeric methyl ketones,  $\alpha$ -methylionone,  $\beta$ -methylionone,  $\gamma$ -methylionone and  $\delta$ -methylionone can be prepared by fractional crystallisation of their semicarbazones (H. Köster, *J. pr. Chem.* 1935, [ii], 1 &, 249; *Deut. Parfümerie-Ztg.* 1935, 21, 259).

Methyl  $\beta$ -Naphthyl Ketone has a fine neroli-like odour and is widely used; it can be obtained, together with the  $\alpha$ -isomer, by the action of acetyl chloride on naphthalene in the presence of aluminium chloride using chlorobenzene as solvent (L. E. Chopin, *Bull. Soc. chim.* 1924, [iv], 35, 610) and a higher proportion of the  $\beta$ -ketone is obtainable by using nitrobenzene as solvent (C. A. St. Pfau and A. Ofner, *Helv. Chim. Acta*, 1926, 9, 669; S. M. Rivkin, *Amer. Chem. Abstr.* 1935, 29, 5102). Methyl  $\beta$ -naphthyl ketone has m.p. 54°, b.p. 172°/11 mm., *semicarbazone* m.p. 236-237°.

Jasmone is the ketone present in jasmine blossom oil which imparts the characteristic jasmine odour. In 1933 it was shown independently by Treff and Werner (*Ber.* 1933, 66 [B], 1521), and by Ruzicka and Pfeiffer (*Helv. Chim. Acta*, 1933, 16, 1208) that this ketone has the structure

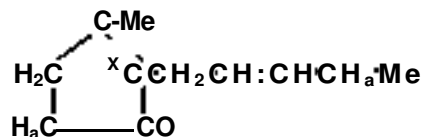

and it was prepared synthetically in 1935 (W. Treff and H. Werner, *ibid.* 1935, 68 [B], 640; *c.f.* H. Hunsdiecker, *ibid.* 1942, 75 [B], 460). Numerous ketones were synthesised in attempts to simulate the jasmone-like odour in more

easily synthesized structures and a number of these compounds are stated to have been made available under various trade names, usually in admixture with other bodies (see, e.g., H. Werner, *Fette u. Seifen*, 1938, 45, 623; V. Isagulyantz, *Riechstoffindustrie*, 1936, 11, 84; B.P. 451462, 1935; G.P. 639455, 667156, 1935; 693863, 1936; R. L. Frank *et al.*, *J. Amer. Chem. Soc.* 1944, 66, 4).

## ESTERS.

Certain valerates and isovalerates have been used for a long time in tobacco perfumery and in fruit essences, and the constants, odours, and properties of a number of these esters have been described by Müller (*Riechstoffindustrie*, 1931, 6, 4). The esters of formic acid (for preparation of the acid, see *Organic Syntheses*, Coll. Vol. I, p. 276) appears to have properties which render them potentially of value to the perfumery trade (W. A. Poucher, "Perfumes, Cosmetics, and Soaps," Chapman and Hall, Vol. I, 5th ed., 1941). Bertram (G.P. 80711, 1893) has described a general method of preparing esters of terpenic alcohols which involves treating the alcohols or essential oils containing these compounds with the appropriate acid at low temperatures in the presence of a little mineral acid. Various other methods are available and are referred to below in the methods described for preparing esters of special types. The preparation and properties of a number of esters derived from n-decyl alcohol have been described (G. Komppa and Y. Talvitie, *J. pr. Chem.* 1932, [ii], 135, 200). Esters of cinnamic acid are of interest in perfumery (K. Braun, *Deut. Parfümerie-Ztg.* 1930, 16, 6) and suitable methods for preparing these esters have been published; e.g., methyl ester (C. N. Riiber, *Ber.* 1915, 48, 827), ethyl (E. Fischer and A. Speier, *ibid.* 1895, 28, 3254; A. Bogojawlensky and J. Narbutt, *ibid.* 1905, 38, 3349; *Organic Syntheses*, 1929, 9, 38), isobutyl (J. J. Sudborough and K. J. Thompson, *J.C.S.* 1903, 83, 676), and benzyl esters (G.P. 127649, 1900). A number of esters derived from cinnamyl alcohol have valuable perfumery properties (*Deut. Parfümerie-Ztg.* 1930, 16, 6). Esters obtained from benzyl alcohol are of the greatest importance in perfumery. The formate can be obtained by the reaction between the mixed anhydrides\* of formic and acetic acids and benzyl alcohol (G.P. 115334, 1899)\* or by passing a mixture of benzyl alcohol and formic acid over titanium dioxide at 150° (P. Sabatier and A. Mailhe, *Compt. rend.* 1911, 152, 1045). Benzyl acetate, which has a characteristic jasmine-like odour, is one of the most widely used\* synthetics. According to Herold (*Deut. Parfümerie-Ztg.* 1931, 17, 362), it is derived commercially by heating together benzyl chloride, sodium acetate\* and acetic acid (G.P. 41507, 1887) or heating the chloride with acetic anhydride in the presence of a metallic catalyst (Swiss P. 169040, 1933) or by acetylating benzyl alcohol. The ester derived by the latter method is generally considered to possess advantages for use in fine perfume mixtures. Benzyl propionate (M. Conrad and W. R. Hodgkinson, *Annalen*, 1878, 193, 311) is sometimes used with benzyl acetate in artificial jasmine oils. Benzyl iso-

valerate (G.P. 165897, 1904) and benzyl isovalerate (E. H. Volwiler and E. B. Vliet, *J. Amer. Chem. Soc.* 1921, 43, 1673) are also found useful in perfumery, and benzyl benzoate (G.P. 268621, 1912; L. Claisen, *Ber.* 1887, 20, 649; *Organic Syntheses*, 1922, 2, 5) is widely used because of its bland odour and good solvent properties for solids such as the artificial musks. The characteristics and odour values of various esters of propionic acid have been described by Müller (*Deut. Parfümerie-Ztg.* 1931, 17, 30) and of esters of butyric and isobutyric acid by Kjelsberg and Müller (*ibid.* 1928, 14, 235). Ethyl pyruvate (L. Simon, *Bull. Soc. chim.* 1895, [iii], 13, 476) is used in traces in certain fancy perfumes. Esters of "amyl alcohol" are prepared by the usual methods and some of the esters are used in perfumery. Commercial amyl alcohol is a constituent of fusel oil produced by fermentation processes and is usually a mixture of isoamyl and active amyl alcohol in varying amounts depending upon the source (potatoes, molasses, etc.). Fusel oil is used in the manufacture of commercial esters, and used as thus the amyl esters are usually mixtures of isomeric forms. Methyl salicylate (oil of wintergreen) is used mainly in flavouring tooth pastes and mouth washes and synthetically it can be obtained by refluxing a mixture of salicylic acid, methyl alcohol, and a catalyst such as sulphuric acid (U.S.P. 1814853, 1931; 1905144, 1933).

Linalyl Acetate has an odour almost identical with that of terpenless bergamot oil and is widely employed in perfume compositions. Both natural and synthetic linalool (and therefore presumably the acetate also) consists of an inseparable mixture of 2:6-dimethyl-2-octadien-6-ol and 2:6-dimethyl-1-octadien-6-ol (J. L. Simonsen and L. N. Owen, "The Terpenes," 2nd ed., Cambridge, 1947, i, 62). Esterification of this tertiary alcohol is especially difficult because on treatment with acetic anhydride the acetylation is accompanied by isomerisation and cyclisation, so that a mixture of the esters of linalool, geraniol, nerol, and terpineol is produced, and in addition terpenes are formed by loss of the elements of water (V. Isagulyantz and E. Smolyaninova, *Biechtstoffindustrie*, 1933, 8, 194). The pure ester can be prepared by the action of acetic anhydride on the sodium salt of linalool (F. Tiemann, *Ber.* 1898, 31, 839). It is claimed that satisfactory yields are obtained by acetylating in the presence of an inert diluent such as xylene (R. Knoll and A. Wagner, "Synthetische und Isolierte Riechstoffe," Halle, a.F., 1928, p. 211). Fernet (*Seifens-Ztg.* 1936, 63, 707, 739) found that by refluxing a mixture of linalool, acetic anhydride, and sodium acetate for varying periods the ester content (as linalyl acetate) rose to 58% after 60 minutes and then slowly decreased. In another process acetylation is carried out below 40° using as catalyst a small proportion of an acetic acid-phosphoric acid mixture (V. Isagulyantz and E. Smolyaninova, *Riechstoffindustrie*, 1933, 8, 194). Houben (G.P. 162863, 1903) prepared linalyl acetate by the action of acetic anhydride upon the Grignard compound derived from methylmagnesium chloride and linalool.

Terpinyl Acetate is another widely used ester. Bertram (G.P. 67255, 4892) observed that treatment of turpentine oil (pinene) with acetic anhydride in the presence of sulphuric acid gave a product from which terpinyl acetate could be separated by fractionation. A mixture of bornyl and terpinylacetates is obtainable by treating  $\alpha$ -pinene with a suspension of Japanese clay in acetic acid (T. Kuwata, Amer. Chem. Abstr. 1937, 31, 3899) and a 35-40% yield of terpinyl acetate has been claimed (T. Kuwata, *ibid.* 1939, 33, 8593) to be obtainable from limonene and acetic acid using Japanese clay as condensing agent. Paillard and Tempia (Helv. Chim. Acta, 1931, 14, 1314) obtained satisfactory yields of the acetate by acetylating terpineol using xylene or French turpentine oil as diluent. Houben (Ber. 1906, 39, 1742) prepared terpinyl acetate by heating the reaction product obtained from terpineol and benzylmagnesium chloride with acetic anhydride. The ester is difficult to saponify and for quantitative saponification prolonged boiling with alcoholic potassium hydroxide is necessary (E. Gilde-meister, Die Atherischen Ole, 1931, 1, 687) or the use of a solution of potassium hydroxide in ethylene glycol mono-ethyl ether (H. M. Perry and T. F. West, Analyst, 1942, 67, 159). The preparation of other bornyl and terpinyl esters has been described by Bertram (G.P. 80711, 1893) and Houben (G.P. 162863, 1803; Ber. 1906, 39, 1746; *ibid.* 1931, 64 [B], 246). Commercial synthetic bornyl acetate usually consists of a mixture of the acetates of borneol and fionorneol and can be derived directly from pinene (B.P. 306385, 1928).

#### Methyl Heptynecarboxylate,

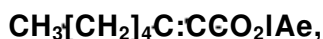

frequently incorrectly termed "methyl heptene carbonate," has a violet-like odour and is used in various perfume compositions. An excellent review of the preparation of such acetylenic esters has been provided by Valli-Donan (Amer. Perfumer, 1923, 18, 133), e.g., *w*-heptaldehyde is converted by treatment with phosphorous pentachloride into 1:1-dichloroheptane, which gives heptyne with potassium hydroxide. The sodium compound or heptyne,

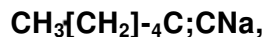

can be converted directly into methyl heptynecarboxylate (i) by reaction with methyl chloroformate, or (ii) by treatment in ethereal suspension with carbon dioxide to give the corresponding acetylenic acid, which is then esterified.

Methyl Benzoate (Niobe oil) (L. Carius, Annalen, 1859, 110, 210; C. Graebe, *ibid.* 1905, 340, 245; R. Meyer and O. Spengler, Ber. 1905, 38, 1332; G.P. 506437, 1929; 563969, 1930; 590052, 1931) and ethyl benzoate (E. Fischer and A. Speier, Ber. 1895, 28, 3253; P. Sabatier and A. Mailhe, Compt. rend. 1911, 152, 360) are both used in certain types of perfume compositions.

Methyl Anthranilate has been detected in a number of essential oils and the synthetic ester is widely utilised in preparing perfume mixtures. It can be prepared by treating anthranilic acid

VOL. IX.—19

with methyl alcohol in the presence of hydrogen chloride (G.P. 110386, 1898; 113942, 1899), sulphuric acid (H. Meyer, Monatsh. 1904, 25, 1201), or boron trifluoride (F. J. Sowa and J. A. Nieuwland, J. Amer. Chem. Soc. 1936, 58, 271) and by reducing methyl *o*-nitrobenzoate with stannous chloride and hydrochloric acid (G.P. 120120, 1898). Methyl anthranilate has m.p. 23-5°, b.p. (127°/11 mm.,  $n_D^{26}$  1.163. Ethyl anthranilate has a definite orange-blossom odour similar to that of the methyl ester but with a rather finer and sweeter quality. It can be prepared from anthranilic acid (E. Bamberger and A. v. Goldberger, Annalen, 1899, 305, 362) and from phthalimide (G.P. 139218, 1902). Ethyl anthranilate has m.p. 13°, b.p. 137-138°/14 mm.,  $n_D^{25}$  1.5649,  $\rho_f$  1.1174.

Methyl N-Methylantranilate was first detected (1900) in tangerine oils and has since been found in a number of essential oils. The synthetic ester, m.p. 18.5°, b.p. 130-131/13 mm.,  $n_D^{15}$  1.120, has been used widely in preparing artificial tangerine and neroli oils and in perfumery compositions. N-Methylantranilic acid can be prepared from anthranilic acid and dimethyl sulphate in sodium hydroxide (B. Willstätter and W. Kahn, Ber. 1904, 37, 401) or acetic acid solution (J. Houben and W. Brassert, *ibid.* 1906, 39, 3233); it can be esterified by the usual methods (G.P. 122568, 1900).

During more recent years other more complex esters derived from terpenic alcohols have been advertised but the published literature is scanty. For possible methods of preparation, see U.S.P. 2170185, 1935; J. Bred\* and H. Hof, Ber. 1900, 33, 21; A. Verley, Bull. Soc. chim. 1927, [iv], 41, 788.

#### NITROGEN-CONTAINING BODIES.

Artificial Musks (see Vol. VIII, 2536).—Baur (Ber. 1891, 24, 2832; G.P. 47599, 1888; 62362, 1891) found that various nitro-derivatives of benzene homologues possessed the odour of musk and this work was extended by others (G.P. 72998, 77299, 1893). 2:4:6-Trinitro-1:3-dimethyl-5-tert.-butylbenzene (xylene musk) is still used in perfumery and can be prepared by nitrating *m*-tert.-butyl-*m*-xylene (F. Ullmann, Enzyklopadie, 1931, 8, 846). When *m*-tert.-butyl-*m*-xylene is brought into reaction with acetyl chloride in the presence of aluminium chloride, the product (1:3-dimethyl-5-tert.-butyl-4-acetylbenzene) on nitration gives 1:3-dimethyl-5-tert.-butyl-2:6-dinitro-4-acetylbenzene which is used in perfumery under the name *musk ketone* (G.P. 87130, 1894; A. Bauer, Ber. 1898, 31, 1344; 1900, 33, 2562). *Musk antifer-Pitt* (n, methyl-2:6-dinitro-3-methoxy-4-tert.-butylbenzene) can be prepared by condensing *m*-cresyl methyl ether with tert.-butyl chloride and nitrating the product (G.P. 62362, 1891; U.S.P. 2007234, 2007241, 1934). Rarer varieties of artificial musks have been reviewed by Noelting (Perf. and Essent. Oil Bee. 1922, 13, 76; cf. B.P. 470550, 1936).

In dole is used to a limited extent in perfumery. Shorygin and Polyakova (Amer. Chem. Abstr. 1942, 36, 3802) investigated various methods of preparation and considered that Reissert's method (Ber. 1897, 30, 1045) was most

suitable. It is obtainable from indoxyl melt (F. N. Stepanov and K. S. Polyakova, Amer. Chem. Abstr. 1942, 36, 3802); from o-formotoluidide and potassium *tert*-butoxide (F. T. Tyson, Organic Syntheses, 1943, 23, 42) and by a series of reactions from dichloroethyl ether and aniline (A. Treffler, B. II, 1945, 129). Indole has m.p. 52-63° (v. Vol. VI, 450).

Skatole has been detected in civet and is utilised to some extent in perfumery. It can be prepared from coal tar (G.P. 515543, 1928) or synthetically by cyclisation of propionaldehyde phenylhydrazone (A. E. Arbusow and W. M. Tschirwinsky, Ber. 1910, 43, 2301; G.P. 238138, 1911) or by degradation of 2-carboxyindole-3-acetic acid (F. E. King and P. L'Ecuyer, J.C.S. 1934, 1902). Skatole has m.p. 95° (v. Vol. VI, 4636). Other  $\alpha$ -substituted derivatives of indole possess odours of potential value in perfumery (T. F. West, H. J. Strausz, and D. H. R. Barton, "Synthetic Perfumes," Edward Arnold & Co., Ltd., 1948).

Quinoline Derivatives.—In perfumery, 6-methylquinoline and its tetrahydro-derivatives and 7- and 8-methylquinolines find a limited use. They can be prepared conveniently from the appropriate toluidine using modifications of the Skraup reaction (e.g., J. G. F. Druce, Chem. News, 1919, 119, 271; E. W. Cohn, J. Amer. Chem. Soc. 1930, 52, 3685; B.P. 549502, 1941). Tetrahydro-6-methylquinoline (*Civetall*) can be prepared by reducing 6-methylquinoline with tin and hydrochloric acid (E. Bamberger and P. Wulz, Ber. 1891, 24, 2067) or with hydrogen using a nickel catalyst (G. Darzens, Compt. rend. 1909, 149, 1001).

#### LACTONES.

Coumarin (v. Vol. III, 412a).—This lactone, which possesses an odour recalling new mown hay, is used widely in both perfume and flavour mixtures. It can be prepared from salicylaldehyde by the Perkin reaction (e.g., W. H. Perkin, J.C.S. 1868, 21, 53; A. Reychler, Bull. Soc. chim. 1897, [iii], 17, 516; H. Yanagisawa and H. Kondo, J.C.S. 1921, 120, 682; B.P. 438361, 1933; U.S.P. 2204008, 1940; Amer. Chem. Abstr. 1939, 83, 1696); or from coumarin carboxylic acid (G.P. 161171, 1903; 189252, 1905; 440341, 1924; P. May, Perf. and Essent. Oil Rec. 1925, 16, 45). More recently it has been claimed (A. A. Shmuk, Amer. Chem. A. Utr. 1940, 34, 5070) that coumarin can be produced economically from fumaric acid and phenol (cf. e.g., G. Bailey and F. Boettner, Ind. Eng. Chem. 1921, 13, 905). Other methods have been described (e.g., H. Meyer *et al.*, Monatsh. 1913, 34, 1665; G.P. 223684, 1909; 276667, 1912; U.S.P. 1920494, 1933; 2062364, 1936). Coumarin has m.p. 70°, b.p. 291°.

6-Methylcoumarin is used with coumarin in a variety of types of perfume compositions. It can be prepared by the Perkin method from *o*-methylsalicylaldehyde (F. Tiemann and C. Schotten, Ber. 1878, 11, 771; K. S. Chang and P. P. T. Sah, J. Chinese Chem. Soc. 1936, 4, 84) and by heating fumaric or maleic acid with *o*-cresol in the presence of suitable catalysts (G.P. 338737, 1919; 362751, 1921; T. J. Thompson and R. H. Edee, J. Amer. Chem. Soc.

1925, 47, 2558). 6-Methylcoumarin has m.p. 75°, (76-77°), b.p. 190-200°/19 mm.

#### MISCELLANEOUS.

Diphenylmethane, Ph-CH<sub>2</sub>-Ph, has a pleasant geranium-like odour and is of considerable importance in perfumery. It is also a dye-stuff intermediate and numerous methods of preparation have been proposed of which the following are typical: (i) condensing benzyl chloride with benzene in the presence of suitable condensing agents (C. Friedel and M. Balsohn, Bull. Soc. chim. 1880, [ii], 33, 337; C. Radziewanowsky, Ber. 1895, 28, 1136; H. Brederick *et al.*, *ibid.* 1939, 72 [B], 1421; G.P. 281802, 1913); (ii) reducing. Under suitable conditions, diphenylcarbinol (A. E. Tschitschibabin, Ber. 1911, 44, 442) or benzophenone (A. Klages and P. Allendorff, *ibid.* 1398, 31, 999); (iii) heating a mixture of tribenzyl berate, benzene, and aluminium chloride (A. Kaudfmann, G.P. 555403, 1930). Diphenylmethane has m.p. 26-27°, b.p. 120°/10 mm., *n*<sub>D</sub><sup>20</sup> 1.5788.

*trans*-Bromostyrene, PhCH:CHBr, has a strong, sharp, hyacinth-like odour. Technically it is prepared by treating cinnamic acid with bromine to give *trans*-dibromophenylpropionic acid which is converted into *trans*-bromostyrene by steam distillation in the presence of a solution of sodium carbonate (I. Herold, Deut. Parfümerie-Ztg. 1931, 17, 246; C. Duffraisie, Ann. Chim. 1922, [ix], 17, 198; A. Lewinsohn, Perf. and Essent. Oil Rec. 1924, 15, 118; G. Chazal, la Revue des Produits Chimiques, 1919, 22, 178). *trans*-Bromostyrene has m.p. 7°, b.p. 108°/2 mm., *n*<sub>D</sub><sup>16</sup> 1.4269, *n*<sub>D</sub><sup>20</sup> 1.6094.

*trans*-Eugenol and Derivatives.—*trans*-Eugenol is used extensively in carnation and oriental-type perfumes and is an intermediate in the manufacture of vanillin. It can be prepared by fusing eugenol with potassium hydroxide at 200-230° (G.P. 76982, 1892) or by heating potassium eugenoxide in a vacuum or in a stream of indifferent gas at 190-220° (G.P. 179948, 1905). Other processes include heating potassium eugenoxide in concentrated aqueous potassium hydroxide (L. M. Labaune, Rev. Marques Pa\* fums de France, 1939, J7, 10), using amyl alcohol as solvent (G.P. 57808, 1890) or adding diluents for the melt such as azobenzene (B.P. 417072, 1933) or a glycol and triethanolamine (T. F. West, J.S.C. 1.1940, 59, 275). *trans*-Eugenol exists in two forms (F. Boedecker and H. Volk, Ber. 1931, 64 [B], 61), the *cis*-form having *n*<sub>D</sub><sup>15</sup> 1.0851, *n*<sub>D</sub><sup>20</sup> 1.5726, and the *trans*-, m.p. 33°, *n*<sub>D</sub><sup>15</sup> 1.0852, *n*<sub>D</sub><sup>20</sup> 1.5782. The methyl ether is sometimes used in perfumery and can be prepared by treating potassium *trans*-eugenoxide with methyl iodide (G. Ciamician and P. Silber, *ibid.* 1890, 23, 1164) or methyl sulphate (C. Mannich and W. Jacobsohn, Arch. Pharm. 1910, 24S, 151). The benzyl ether is obtained with benzyl chloride (G.P. 65937, 1891; F. J. Pond and F. T. Beers, J. Amer. Chem. Soc. 1897, 19, 828; T. F. West, J.C.S. 1945, 490).

Large Ring Compounds.—*Civetone* (v. Vol. HI, 1946; VII, 143a) is the valuable large ring ketone (L. Ruzicka *et al.*, Helv. Chim. Acta,

1926,9,230; 1942, 26, 604) present in civet; a stereoisomer has been synthesised by Hunsdiecker (Ber. 1943, 76 [B], 142). It is claimed (U.S.P. 1720748, 1927) that the yield of ketone from natural civet can be increased by oxidising the corresponding secondary alcohol, which is also present, to civetone> *1-Muscone* (3-methylcyclopentadecanone) is the odorous principle of natural musk. The est-form of the ketone has been synthesised by Ziegler and Weber (Annalen, 1933, 504, 94; 1934, 512, 164) by cyclisation of 1:14-dicyano-2-methyltetradecane to give a cyclic cyanoketimide mixture which on hydrolysis gave 3-methylcyclopentadecanone. Ruzicka and Stoll (Helv. Chim. Acta, 1934, 17, 1308) prepared the ketone by hydrogenating muscenone. Hunsdiecker (Ber. 1942, 75 [B], 1190, 1197) prepared methyl muscone-o-carboxylate which was converted into *m*-muscone on treatment with 80% sulphuric acid. Ruzicka and co-workers (Helv. Chim. Acta, 1926, 9, 249, 266; Swiss P. 119619, 119620, 119622, 120150, 1925; B.P. 235340, 1925) found that *cydo*\* pentadecanone (used in perfumery under the name "*exaltone*") displayed the strong *J*Bt musk odour of a series of large ring ketones which they synthesised... The preparation of *exaltone* has been studied in detail by Ziegler and co-workers (Annalen, 1933, 504, 122; B.P. 415259, 1933; 438291, 1934). Kerschbaum (Ber. 1927, 60 [B], 902) found that pentadecanamide possessed a characteristic musk odour, and synthesised the compound (G.P. 449217, 1926). Ruzicka and Stoll devised alternative methods of preparation (Helv. Chim. Acta, 1928, 11, 1159; B.P. 294602, 1928) and called the lactone "*exaltolide*." Kerschbaum showed that the musk odour of musk seed oil was due to the presence of the lactone, *ambreUolide*,

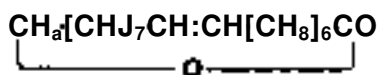

and described a synthetic method of preparation (G.P. 449217, 1926).

Compounds with Ambergris-odour.—Various compounds have been described as possessing the odour of ambergris, e.g., *fiacahydro-j8-naphthaldetyde*; *5:6:7:8-tetrahydro-1-naphthykuieUdehyde*; *ethyl 2:4-diaopropyl-phenylglyddate* (B.P. 372013, 1931); and the nitration products of *dibromobutyl-m-cresyl methyl ether* (Swiss P. 101398, 1921).

Compounds with Russian Leather Odour.—The following compounds are stated to possess the odour of Russian Leather: *p*-*tert*-*butylphenol* (A. Liebmann, Ber. 1881, 14, 184& O. Sandulescu and S. Sabatay, Riechstoffindustrie, 1936,10, 84; U.S.P. 1740854,1927) and homologues of *m*-xylenol containing the *tert*-butyl or *fiopropyl* group in the ortho position to the hydroxyl group (F.P. 783538, 1934; F.P. 775875, 1933).

T. F. W.

PERIDOT. The transparent green variety of olivine {v. this Vol., p. 93a), sometimes used as a gemstone.

D. W.

PERILLA OIL (v. Vol. IV, 846; this Vol., p. 26c).

PERILLALDEHYDE,

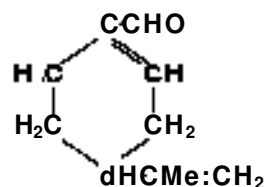

b.p. 104-106°/10 mm.,  $p^{18}$  0-9617,  $n_D$  1-6074,  $[\alpha]_D^{20}$  +135-6°, -146°, *semicarbazone*, m.p. 199-200°, *phenylhydrazone*, m.p. 107-6°, *oxime*, m.p. 102°, 129°. *d*-Aldehyde occurs in false camphor wood oil from *Hernandia peltata*, *l*- in the oil from *Perilla nankinensis*.

J. L. S.

PERILLYL ALCOHOL,

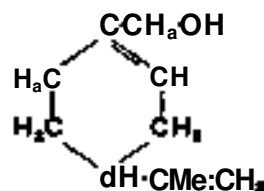

b.p. 119-121°/11 mm.,  $p^M$  0-964,  $n_D^{20}$  1-4996,  $[\alpha]_D$  -68°, *naphthylurethane*, m.p. 146-147°. Occurs in a number of essential oils.

J. L. S.

PERITECTIC REACTION (v. Vol. VII, 596c).

PERNOCTON. Sodium 5-*sec*-butyl-5-*j3*-bromoallylbarbiturate. Sedative and hypnotic. B.P.C. App. XIV (v. SYNTHETIC DRUGS).

D. D.

PEROXIDES AND PERACIDS, IN-

ORGANIC.—The term *per-compound* is used to describe all substances which contain the —O—O—bridge in their molecules. Hydrogen peroxide, H—O—O—H, is the parent substance of the group, metallic peroxy-compounds being derived by the replacement of one or both hydrogen atoms in hydrogen peroxide by cations, whilst peracids of various types are obtained by similar replacements with an acidic group. It is characteristic of all per-compounds that the oxidising properties are associated with the structural relationship to hydrogen peroxide and are not due to enhancement of the valency of other elements in the molecule. Barium peroxide, for example, contains bivalent barium, whilst in the persulphuric acids the sulphur valency is the same as in sulphuric acid. True peroxy-compounds yield hydrogen peroxide on hydrolysis. In a few so called per-compounds, such as manganese peroxide (or dioxide)  $\text{MnO}_2$ , lead peroxide,  $\text{PbO}_2$ , perchloric acid, periodic acid, and permanganic acid, the molecule is not related structurally to hydrogen peroxide, and the oxidising properties are due to the presence in the molecule of an atom in one of its higher valency states.

The Alkali Metal and Alkaline Earth Metal Peroxides.—The preparation and properties of hydrogen peroxide have already been described (v. Vol. VI, 339); those of the metal peroxides are also dealt with in part in the descriptions of the compounds of the metals concerned. The metallic peroxides are formed



most readily by the strongly electropositive elements of the alkali and alkaline-earth groups. These compounds are solids with ionic lattices, one component of which is the  $O^{2-}$  or the  $O_2^{2-}$  ion. The peroxides of these groups are tabulated below.

$Li_2O_2$			
$Na_2O_2$			
$K_2O_2$	$K_2O_3$	$KO_2$	$CaO_2$
$Rb_2O_2$	$Rb_2O_3$	$RbO_2$	$SrO_2$
$Cs_2O_2$	$Cs_2O_3$	$CsO_2$	$BaO_2$

When the alkali metals are heated in excess of oxygen, the final products formed are  $Li_2O$ ,  $Na_2O_2$ ,  $KO_2$ ,  $RbO_2$ , and  $CsO_2$ . The proportion of oxygen in the most stable oxide thus increases with the ionic radius of the metal. Lithium monoxide is white, but the colour of the oxidation product deepens progressively from  $Na_2O_a$  (yellow) to  $CsO_a$  (dark brown). These peroxides of potassium, rubidium, and caesium are also formed by heating the metal hydroxides at  $375^\circ$  in oxygen under pressure (Fischer and Ploetzcr, Z. anorg. Chem. 1912, 75, 1).

The oxide  $Li_2O_2$  is said to be formed in small amounts when lithium is heated in oxygen. It is also formed by oxidation of lithium in liquid ammonia solution (*v. infra*). The remaining oxides of the type  $M_2O_2$  are also formed by carefully controlled oxidation of the alkali metal. Thus,  $K_2O_2$  may be formed by oxidising potassium in the calculated amount of air at  $300^\circ$ , or by oxidation in a carefully limited supply of nitric oxide. A more general method which allows of the isolation of the intermediate oxidation products is to bubble oxygen into a solution of the alkali metal in liquid ammonia at  $-50^\circ$  when the increase in weight serves as a measure of the oxygen absorbed. This method of preparation has yielded peroxides of the type  $M_2O_3$  from potassium, rubidium, and caesium (Joannis, Compt. rend. 1893, 116, 1370). The oxides are precipitated from the ammonia solution and show characteristic colours, - thus, for potassium,

K in liquid $NH_3$ .	$K_2O_2$ .	$K_2O_3$ .	$KO_2$ .
Blue.	White.	Red.	Orange.

The oxide  $K_2O_3$  is formed from  $KO_2$  by heating at  $480^\circ/1$  mm. All of these oxides form ionic crystals containing the ions  $O_2^{2-}$  and  $O^-$  in the types  $M^+O_2$  and  $M^+O_2^-$ , respectively. It is provable that the type  $M^+O_2^-$  should be formulated as a lattice compound  $2MO_2 \cdot M_2O_2$  in which both anions are present. The relationship between peroxide and superoxide is thus due to the existence of a peroxide ion in the solid state. This may persist over a small temperature range on fusion, but in all cases the compounds lose oxygen at a sufficiently high temperature. The oxide  $KO_2$  with water forms hydrogen peroxide and liberates oxygen, whereas  $K_2O_2$  forms only hydrogen peroxide

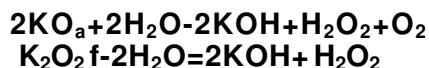

Hydroperoxides.—The replacement of only one of the two hydrogen atoms of hydrogen peroxide by a metal atom leads to the formation

of hydroperoxides. Substances of this group are formed in various ways, and by some metals which do not form simple peroxides. Among the alkali metals, sodium hydroperoxide,  $NaO_2H$  is formed from  $Na_2O_2$  by reaction with an ice-cold mixture of alcohol and concentrated nitric or sulphuric acid, or by the action of metallic sodium on an ether solution of hydrogen peroxide (D'Ans and Friederich, Ber. 1910, 43, 1880). The latter preparation indicates the relationship to hydrogen peroxide. The compound decomposes slowly at room temperature, and forms the addition compounds



and  $NaOOH \cdot 0.5H_2O_2 \cdot 2H_2O$  with hydrogen peroxide. Similar hydroperoxides of potassium, rubidium, and caesium may be prepared.

Ammonium hydroperoxide.  $NH_4OOH$ , is formed when dry ammonia reacts with a solution of 98% hydrogen peroxide in dry ether at  $-10^\circ$ . It is a crystalline solid, m.p.  $14^\circ$ , which is transformed by further reaction with gaseous ammonia into ammonium peroxide,  $(NH_4)_2O_2$ , m.p. ca.  $-40^\circ$ , a compound which is less stable than the hydroperoxide.

Peroxides of the Alkaline Earth Metals.—The three peroxides  $CaO_2$ ,  $SrO_2$ , and  $BaO_2$  show a variation in stability which is analogous to that in the alkali-metal series. Of these three elements, barium has the largest cation radius (1.3-1.4 A.) and its peroxide is the most stable, being formed by heating the monoxide in air. There is a reversible equilibrium between the monoxide and the dioxide which formed the basis of the now obsolete Brin process for obtaining oxygen from the air. The peroxides  $BaO_2$  and  $KO_2$  are related in that both have the calcium carbide type of crystal lattice with cations and anions of similar dimensions. Thus the radius of the potassium ion is 1.33 A., whilst the internuclear distances between the oxygen atoms of the ion  $O_2^{2-}$  in  $KO_2$  is 1.28, the corresponding figure for  $O_2^{2-}$  in  $BaO_2$  being 1.31 A.

Strontium peroxide is formed from the monoxide by heating in oxygen under pressure; the conversion is about 15% at  $400^\circ$  and 100 atm. of oxygen. The compound is, however, formed by the action of oxygen on a solution of strontium in liquid ammonia, or when strontium is oxidised by oxygen under pressure. Calcium, which has the smallest cation radius of the group, does not form its peroxide by the action of oxygen on the heated monoxide, and the yield from the oxidation of calcium in liquid ammonia solution is also small. Hydrated peroxides of the type  $M^+O_2 \cdot 8H_2O$  are formed by all the alkaline-earth metals, that of calcium, for example, being produced when hydrogen peroxide or sodium peroxide reacts with milk of lime or calcium salts. It finds technical applications as a bleaching agent and for antiseptic purposes, and is moderately stable.

Other Metallic Peroxides.—The less electropositive metals form in general peroxides or hydroperoxides which are less well defined. Some of these are structurally intermediate between the peracids and the peroxides.

Magnesium peroxide is an interesting example of the sort of compound obtainable. Hydrogen peroxide in alkaline solution precipitates from magnesium sulphate a compound  $MgO \cdot MgO_a$ . This compound is also formed by the interaction of sodium peroxide and magnesium salts in presence of a small amount of water. The products from these reactions may contain varying amounts of magnesium hydroxide. Decomposition by water occurs readily in the freshly precipitated state, but the stability of the dry material is much greater. Various antiseptics based on magnesium peroxide are described, all of which owe their action to the presence of a true peroxide which yields hydrogen peroxide with acids (see W. Machu, "Wasserstoff-peroxyd und die Perverbindungen," Vienna, 1937).

Zinc and cadmium form similar ill-defined peroxides. Thus by the action of 30% hydrogen peroxide on an ammoniacal zinc sulphate solution a product approximating to the formula  $ZnO_2 \cdot Zn(OH)_2$  results. A true peroxide,  $ZnO_2 \cdot 0.5H_2O$ , is formed when an ether solution of hydrogen peroxide reacts with zinc ethyl. Magnesium and cadmium peroxides may be formed similarly. It is possible that in some of these preparations the hydroperoxido group,  $Zn-O-O-H$ , is present. Preparations of medicinal use are obtained in the same way as those containing magnesium peroxide.

Many other metals form peroxy-compounds of a more or less definite character. Thus copper, silver, and mercury may all form peroxides, though in some instances, as for example, in the anodic oxidation of silver, it is more likely that the product is an oxide of a higher valency state of the metal. These supposed peroxides have not been shown to yield hydrogen peroxide on treatment with acids.

Peroxides of Weakly Electropositive Elements of Group IV, V, and VI. Certain of the weakly electropositive elements of Groups IV, V, and VI form peroxy-compounds which are intermediate in character between the peroxides of the more electropositive elements and the true per-acids. Thus titanium, zirconium, hafnium, and cerium form compounds of the type  $MO_3 \cdot 2H_2O$  when hydrogen peroxide reacts in alkaline solution with solutions of their salts. These substances are precipitated in an amorphous form.

The formula of the titanium compound  $TiO_3 \cdot 2H_2O$  is best represented as a hydroperoxide derived from the ortho-form of the metal hydroxide (Schwarz and Giese, Z. anorg. Chem. 1928, 176, 209).

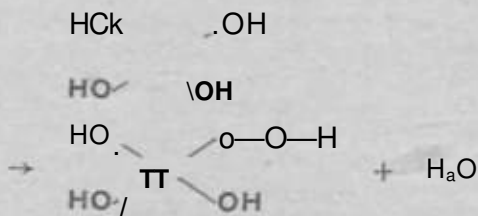

The compound loses oxygen when suspended in water and with dilute acids yields hydrogen peroxide. The formula is further supported by determinations of the ratio of oxide to active oxygen and to water (=1:1:2). The compound

is soluble in potassium hydroxide in presence of hydrogen peroxide and from the solution a potassium salt,  $K_4TiO_6$ , may be isolated, which is formulated as a derivative of the ortho-peroxy-acid.

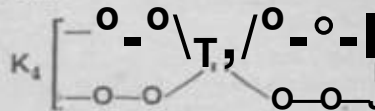

The titanium compounds serve to indicate the type of compound formed in this group. Structures are not in every case well established, but it is at least clear that all the so-called peroxides of this group contain either the  $-O-O-$  bridge or the  $-O-O-H$  group, either of which leads to the liberation of free hydrogen peroxide on treatment with acids.

Acid zirconium sulphate solutions when treated with hydrogen peroxide at 0° give a precipitate consisting of a zirconium peroxysulphate,  $Zr_2O_3SO_4 \cdot 8H_2O$ , which has been formulated as

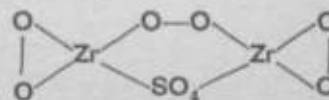

Titanium forms a somewhat similar peroxy-compound  $K_2[Ti(O_2)(SO_4)_2] \cdot 3H_2O$ , which is stable in dilute sulphuric acid and which is responsible for the yellow colour used in the colorimetric determination of titanium with hydrogen peroxide. This colour is bleached by fluoride ions because of the following reaction:

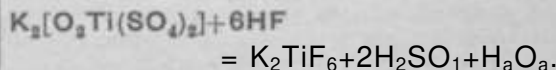

The boundary between peroxides and per-acids is extremely ill defined, and so it arises that in Groups V and VI of the Periodic Table the elements vanadium, niobium, tantalum, chromium, molybdenum, tungsten, and uranium form a number of weak peracids, some of which are known to give well-defined salt-like derivatives.

Acid solutions of vanadates, for example, give a red colour when treated with hydrogen peroxide, and it is possible to precipitate solid per-vanadates by the addition of alcohol. The presence in the red sulphuric acid solution of a peroxy-vanadyl sulphate,  $(VO_3)_j(SO_4)_3$ , which is transformed by excess of hydrogen peroxide into the acid  $H_3VO_5$ , has been suggested. Niobium and tantalum yield the per-salts  $Na_3NbO_8$  and  $Na_3TaO_6$  when excess of hydrogen peroxide reacts with certain alkali niobates or tantalates.

The chemistry of the perchromates is comparatively complex, a number of per-compounds being formed by the action of hydrogen peroxide on chromic acid. The deep blue ether-soluble compound formed when solutions containing chromic acid are treated with hydrogen peroxide is now believed to be a true peroxide,  $CrO_6$  (for the evidence bearing on the constitution of the chromium per-compounds, see H. J. Emeleus and J. S. Anderson, "Modern Aspects of Inorganic Chemistry," Routledge, 1938). Reaction of this blue substance with alcoholic

solutions of an alkali gives a series of blue salts—the "blue perchromates"—of the general formula  $M^1H_2CrO_7$ , whilst a further series of perchromates—the "red perchromates"—of the type  $M^jCrO_8$  is formed in the reaction between hydrogen peroxide and alkaline solutions of chromic acid below  $0^\circ$ . When their solutions are acidified, oxygen is evolved and the blue ether-soluble peroxide is formed. It is believed that the blue perchromates should be formulated as  $K_2CrO_{12} \cdot 2H_2O$  (I) and the red perchromates as  $M_6Cr_2O_{16}$  (II).

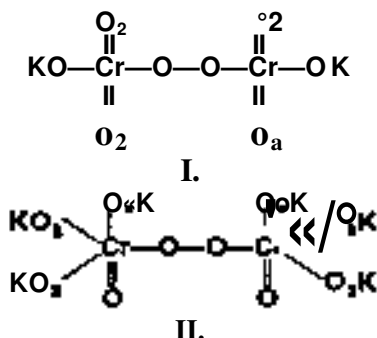

The chemistry of the permolybdates is likewise\* complicated. Solutions of normal molybdates give a deep colour with hydrogen peroxide and on adding solid potassium molybdate to ice-cold hydrogen peroxide, the unstable salt  $K_2MoO_8$  crystallises. This may have four peroxy-groups co-ordinated round molybdenum in the anions. With polymolybdates various more complex substances are formed, the formulation of which has not yet been settled. Tungsten forms a series of unstable pertungstates,  $M^jWO_8$ , analogous to the simple permolybdates, and in addition a number of more complex peroxy-bodies of unknown constitution.

Uranyl salts react with hydrogen peroxide forming an amorphous yellow precipitate of  $UO_4 \cdot 2H_2O$ , the water in the molecule of which cannot be removed without decomposition. This may possibly be formulated as

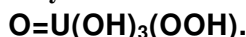

True peruranates are formed by the action of alkalis and hydrogen peroxide on uranyl salts. These include salts such as  $Na_4UO_8 \cdot 8-9H_2O$  and  $Na_4U_8O_{10} \cdot 4H_2O$ , attempts to formulate which are based by Rosenheim and Daeir (Z. anorg. Chem. 1932, 208, 81) on determinations of the atomic ratios of active oxygen to uranium.

The Persulphates and Percarbonates. —Permono- and perdisulphuric acids represent a different type of peroxy-compound from the foregoing in that, though derived from hydrogen peroxide and structurally related to it, they contain in their molecules respectively one and two strongly acidic  $HSO_3$  groups. The acids therefore behave as strong acids, in contrast to the much weaker hydroperoxide compounds, in which the functional group is the weakly acidic  $-O-O-H$  group.

The relationship of Caro's acid,  $H_8SO_5$  (permonosulphuric acid), and perdisulphuric acid,

$H_2SO_5$ , to hydrogen peroxide is settled by their synthesis as colourless crystalline solids by the interaction of anhydrous hydrogen peroxide and cooled chlorosulphonic acid, when, according to the proportions of the reactants taken, one or two of the hydrogen atoms of hydrogen peroxide may be replaced by the  $HSO_3$  radical: —

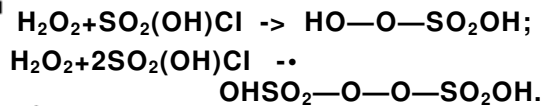

The presence of an oxygen bridge in the structure is further indicated by a study of the crystal structure of potassium persulphate, which shows the two sulphur atoms in the  $S_2O_8^{2-}$  anion linked by two oxygen atoms.

The percarbonates can, like the persulphates, be prepared by the familiar method of electrolysis with a well-cooled cathode and a high anode current-density. Electrolysis of a concentrated potassium carbonate solution in this way yields a pale blue potassium percarbonate,  $K_2C_2O_6$ , which, from its mode of formation, must have the formula (I).

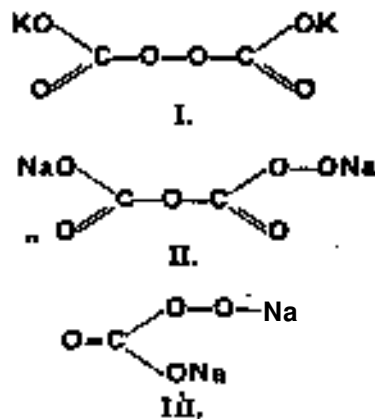

A second series of percarbonates is formed by the action of carbon dioxide on sodium peroxide, when two compounds  $Na_2C_2O_6$  and  $Na_2CO_4$  are obtained according to the proportions of the reactants taken. These compounds have tin, formula (II) and (III), respectively, which are consistent with the mode of preparation, the proportion of active oxygen, and the fact that the third compound is formed when phosgene reacts with sodium peroxide.

Of the remaining elements of Group IV only germanium and tin form true peracids. A solution of sodium metagermanate, for example, when treated with 30% hydrogen peroxide at  $0^\circ$  yields two salts,  $Na_2Ge_2O_7 \cdot 4H_2O$  and  $Na_2GeO_6$ , to which the formula (IV) and (V) below are assigned.

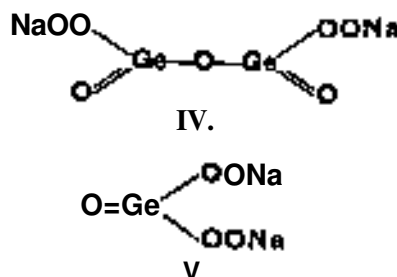

Other Per-acids.—*Pemitric Acid*,  $\text{HNO}_4$ , is formed, together with nitric acid, when nitrogen pentoxide reacts with anhydrous hydrogen peroxide:

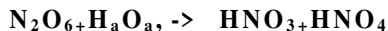

It is a very unstable compound, with, as might be expected, strong oxidising properties.

*Permonophosphoric Acid*,  $\text{H}_3\text{PO}_6$ , is produced similarly by dissolving phosphorus pentoxide in hydrogen peroxide. It is interesting to note that in this acid, as in permonosulphuric acid, the strongly acidic hydrogen atoms are those of the O—H groups attached directly to the phosphorus atom and not that in the residual —O—H group of hydrogen peroxide. Electrolytic production of perdisulphates was first achieved by Fichter (Helv. Chim. Acta, 1928, 11, 323) by electrolysis of concentrated solutions of potassium hydrogen phosphate containing a high concentration of potassium fluoride. From the resulting solution potassium perdisulphate,  $\text{K}_2\text{S}_2\text{O}_8$ , may be isolated. It is a comparatively stable salt with strong oxidising properties. Perdisulphuric acid is similar to perdisulphuric acid in that it may be hydrolysed in strongly acid solution in turn to permonophosphoric acid and hydrogen peroxide.

Perborates are also known, though the existence of a perboric acid does not appear to have been investigated. Potassium metaperborate,  $\text{KBO}_3 \cdot \text{H}_2\text{O}$ , is precipitated by alcohol from solutions of metaborates to which hydrogen peroxide has been added, and a sodium perborate  $\text{NaBO}_3$  is formed by the action of boric acid on sodium hydroperoxide.

Compounds containing Hydrogen Peroxide of Crystallisation.—A number of salts are known, containing hydrogen peroxide of crystallisation which, though not structurally related to the true peroxides, do show many of their oxidising reactions. Aqueous solutions of such compounds display all the reactions of hydrogen peroxide and thus differ from salts of true peracids, from which hydrogen peroxide is formed as a rule only slowly by hydrolysis. The peracids and their salts give an immediate liberation of iodine from potassium iodide, whereas compounds with hydrogen peroxide of crystallisation liberate iodine only slowly. In addition, in the latter case, hydrogen peroxide may be extracted with ether from the aqueous solutions.

Solutions of sodium carbonate containing hydrogen peroxide give, when treated with alcohol, a precipitate of the salt



which has been used as a constituent in washing powders. The compound usually known as sodium perborate is similar in type and has the constitution  $\text{NaBO}_2 \cdot \text{H}_2\text{O}_2 \cdot 3\text{H}_2\text{O}$  and may be crystallised from alkaline borax solutions treated with hydrogen peroxide or sodium peroxide. It may also be produced on a technical scale by electrolysis of solutions containing both sodium borate and sodium carbonate. Like the sodium carbonate derivative, it is used in the preparation of washing powders and bleaching agent\*. Similar compounds are obtainable from sodium silicate, the compound  $\text{Na}_2\text{SiO}_3 \cdot \text{H}_2\text{O}_2 \cdot \text{H}_2\text{O}$ ,

for example, being formed by dissolving sodium metasilicate in a 30% solution of hydrogen peroxide,

D. S. P.

**PEROXIDES AND PERACIDS, ORGANIC.** Organic peroxides may be considered as alkyl (or aryl) derivatives of hydrogen peroxide, and are formed as intermediates in many reactions involving oxidation, such as autoxidation, bacteriological oxidation of alcohols, drying of oils, explosion in internal combustion engines, photochemical processes, etc. They may be prepared by the following general reactions:

1. Alkylation of hydrogen peroxide.
2. Oxidation of alkyl radicals.
3. Dehydrogenation of hydroxy-compounds.
4. Treatment of olefins, aldehydes, ketones, hydroxy compounds or alkoxy compounds with oxygen, ozone or hydrogen peroxide.
5. Decomposition of ozonides.

Method 1, and in some cases 4 and 6, yield alkyl peroxides in pure condition.

In general the organic peroxides are unstable explosive substances possessing powerful oxidising properties. With a few exceptions they liberate iodine quantitatively from potassium iodide and are estimated by modifications of this reaction (Liebhafsky and Sharkey, J. Amer. Chem. Soc. 1940, 62, 190; Kakatur and Jelling, *ibid.* 1941, 63, 1432), by reduction with titanous or stannous salts, or by colorimetric methods involving oxidation of ferrous to ferric salts in the presence of a thiocyanate (Bolland *et al.*, Trans. Inst. Rubber Ind. 1941, 17, 29), of indigosulphonic acid (Rostovtseva, Org. Chem. Ind. Russ. 1936, 2, 166), of 2:5-bis-(2:4-dimethyl-N-pyrryl)-3:6-dibromohydroquinone (Pratesi and Celeghini, Gazzetta, 1936, 66, 365), or of a leucobase obtained by the action of sodium thiosulphate on Methylene Blue (Popesco, Chim. et Ind. 1939, 42, 25). Some peroxides may be estimated polarographically (Koshkin *et al.*, Zavodskaya Lab., 1939, 8, 677; 1940, 9, 166). True peroxides containing the —O—O— bridge may be differentiated from false peroxides (compounds with attached hydrogen peroxide) by the ability of the former to liberate iodine without also liberating oxygen from phosphate-buffered potassium iodide (Schwarz and Heinrich, Z. anorg. Chem. 1935, 223, 387).

The peroxides are conveniently classified as follows:

### I. Transannular Peroxides\*

(Bergmann and McLean, Chem. Review\*, 1941, 28, 367).

These contain a 1:4-peroxide bridge across a six-membered ring and are characterised by their ready formation under the influence of light and their ability by their ability to undergo rearrangement or even to release oxygen.

*Ascaridole*,



is an oil, b.p. 80-81°/4 mm., with unpleasant

taste and smell, which was recognised in 1908 as the principal anthelmintic constituent of chenopodium oil. It decomposes violently at 130-150°, but if heated in a solvent it isomerises to the ether epoxide



*Rubrene Peroxide* is remarkable for its ability to dissociate into rubrene and oxygen when heated *in vacuo*,

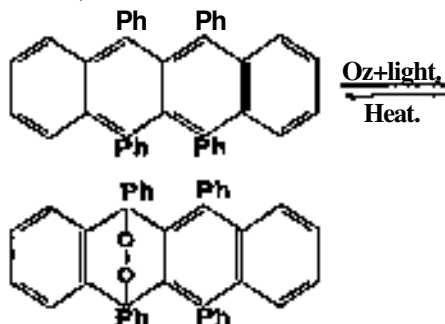

and this may be explained by the resonance energy gained by reversion to the rubrene structure. Dufraisse (Bull. Soc. chim. 1939, [v], 6, 422) has shown that many polynuclear aromatic hydrocarbons containing the resonating system

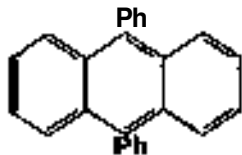

yield dissociating peroxides.

## II. Hydroperoxides.

These substances are products of autoxidation of many olefins, the hydroperoxide group being located at the  $\alpha$ -methylene carbon atom (Farmer, Trans. Faraday Soc. 1942, 38, 348). A characteristic reaction of the hydroperoxide group is liberation of oxygen in the cold when treated with lead tetra-acetate. Hydroperoxides of *cyclohexene* (b.p. 45-47°/0.01 mm., Criegee, Bej. 1939, 72 [B], 1799) *tetralin* (m.p. 56°) and *menthene* can be methylated with dimethyl sulphate and alkali, the methylated derivatives  $R-O-OCH_3$  show only feeble peroxide characteristics (Hock and Lang, Ber. 1942, 75 f£, 300). *Xylene hydroperoxide* has b.p. 105 mm., w£ 1.5322 (*idem, ibid.* 1943, 76 [B], 169).

*Alkyl Hydroperoxides* are obtained by half alkylation of hydrogen peroxide with dialkyl sulphate and alkali (U.S.P. 2223807).

*Methyl Hydrogen Peroxide*,  $Me-O-OH$ , is a pungent liquid, b.p. 38-40°/65 mm., which attacks organic matter and explodes on heating or rubbing (Rieche and Hitz, Ber. 1929, 62 [B], 2458; Z. ansew. Ghem. 1929, 42, 814). It reacts as an oxidising agent in acid solution, but as a reducing agent in alkaline solution, towards which it is very sensitive, decomposition pro-

ceeding with intermediate formation of monohydroxy dimethyl peroxide, the final decomposition products being methanol, formic acid, and hydrogen:

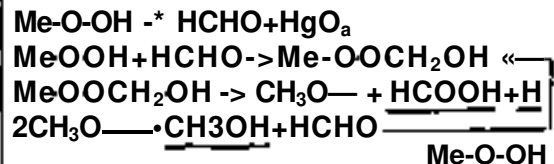

*Barium Methyl Peroxide* is formed when a 30-50% aqueous solution of methyl hydrogen peroxide is treated with excess of baryta. The solution so obtained is filtered and warmed with alcohol; the salt crystallises on cooling. The barium salt is highly explosive, and when dry detonates on touching (Rieche and Hitz, Ber. 1930, 63 [B], 2504). \*

*Ethyl Hydrogen Peroxide*,  $StO-OH$ , b.p. 41-42°/55 mm.,  $n_D^{20}$  1.3800 (Harris, Proc. Roy. Soc. 1939, A, 173, 126) does not evolve much hydrogen in alkaline solution unless formaldehyde is present. "

*tert.-Butyl Hydrogen Peroxide*,  $Me_3C-O-OH$ , is obtained by fractionating an anhydrous solution of hydrogen peroxide in *tert.*-butyl alcohol in the presence of a dehydrating agent. It is stable at room temperature and is only slowly decomposed by alkali (Milas and Harris, J. Amer. Chem. Soc. 1938, 60, 2434).

## III. Hydroxy-alkyl Hydrogen Peroxides,

### $R-CH(OH)-O-OH$ .

These are obtained by interaction between molecular proportions of an aldehyde and hydrogen peroxide in dry ether solution (Reiche and Meister, Ber. 1931, 64 [B], 2328). They readily pass into dihydroxy-dialkyl peroxides, especially in the presence of water, and eliminate water readily forming acids. With aldehydes they do not form *cis*-*trans*-dihydroxy-dialkyl peroxides, but mixtures of *trans*-dihydroxy-dialkyl peroxides (*q.v.*).

Thermal decomposition yields an acid corresponding to the original aldehyde together with an alcohol formed by replacement of the original  $\cdot CHO$  group by  $-OH$  (Spath, Pailer, and Schmidt, *ibid.* 1941, 74 [B], 1552).

*Hydroxymethyl Hydrogen Peroxide*,



is an oil, w£ 1.4205 which explodes on heating (Rieche and Meister, *ibid.* 1935, 68 [B], 1465).

*$\alpha$ -Hydroxyethyl Hydrogen Peroxide*,



is an almost colourless oil, readily soluble in water, alcohol, and ether. With alkali or aqueous  $FeSO_4$ , acetaldehyde and acetic acid are produced:

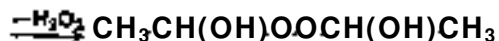

Dehydration with  $P_2O_5$  does not yield an acid, but gives ethylidene peroxide (Rieche and Meister, *ibid.* 1939, 72 [B], 1933):

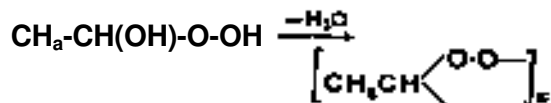

The higher aldehydes yield non-explosive crystalline hydroxy-alkyl hydrogen peroxides: e.g.,  $\alpha$ -hydroxyheptyl hydrogen peroxide, m.p.  $40^\circ$ ;  $\alpha$ -hydroxyoctyl hydrogen peroxide, l.h.p.  $46^\circ$ ;  $\alpha$ -hydroxydodecyl hydrogen peroxide, m.p.  $46-57^\circ$

#### IV. Dialkyl Peroxides,



These are obtained by alkylation of both hydrogen atoms of hydrogen peroxide with 2 mol. dialkyl sulphate and potassium hydroxide (B.P. 568419). Mixed dialkyl peroxides



are obtained by alkylating alkyl hydrogen peroxides. Dialkyl peroxides are highly explosive, colourless volatile liquids, sparingly soluble in water, readily soluble in alcohol and ether. They are only weak oxidising agents, liberating iodine slowly and incompletely from iodides, but may act as dehydrogenating agents under the catalytic influence of  $Fe^{II}$ , e.g.,

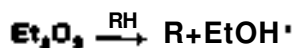

(Wieland and Bossert, *Annalen*\*, 1934, 509, 1).

*Dimethyl Peroxide*,  $CH_3O-O-CN_3$ , is a highly explosive and shock-sensitive gas, b.p.  $13.5^\circ/760$  mm. (Rieche and Brumshagen, *Ber.* 1928, 61 [B], 951). Explosive decomposition yields formaldehyde and methanol,



*Methyl Ethyl Peroxide*,  $CH_3OOC_2H_5$ , obtained by methylating ethyl hydrogen peroxide, is a mobile liquid, b.p.  $40^\circ/740$  mm. (Rieche and Hitz, *ibid.* 1929, 62 [B], 218).

*Diethyl Peroxide* has b.p.  $64^\circ/740$  mm. (Baeyer and Villiger, *ibid.* 1900, 33 [B], 3387).

*Triphenylmethyl Peroxide*,  $Ph_3COOCPh_3$ , m.p.  $185-186^\circ$ , is obtained by oxidation of triphenylmethyl with atmospheric oxygen (Gomberg, *ibid.* 1900, 83, 3154; 1904, 37, 3538). Peroxides of this type are secondary products derived from short-lived  $ROO'$  radicals (Ziegler, *Trans. Faraday Soc.* 1934, 30, 10).

#### V. Monohydroxy-dialkyl Peroxides,



Prepared by the interaction of aldehydes with alkyl hydrogen peroxides in ether solution:

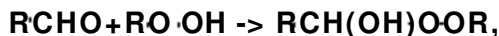

they are fairly stable distillable liquids; under the influence of  $Fe^{II}$  or alkali they decompose, yielding acids and alcohols with evolution of hydrogen.

*Hydroxymethyl Methyl Peroxide*,

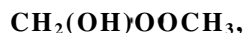

from  $HCHO$  and  $CH_3OOH$ , has b.p.  $45^\circ/17$  mm. It is soluble in alcohol and ether, rather less so in water. Decomposition with alkali gives hydrogen, formic acid, and methanol.

*Hydroxymethyl Ethyl Peroxide*,

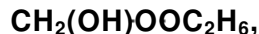

b.p.  $47^\circ/13$  mm., is obtained from formaldehyde and ethyl hydrogen peroxide.

*Hydroxyethyl Methyl Peroxide*,



from acetaldehyde and methyl hydrogen peroxide, has b.p.  $29-31^\circ/22$  mm.

*Hydroxyethyl Ethyl Peroxide*,



is formed from acetaldehyde and ethyl hydrogen peroxide, and has b.p.  $48-52/765$  mm. (Rieche and Hitz, *Ber.* 1930, 63 [B], 2642).

#### VI. Di(hydroxyalkyl) Peroxides,



These are prepared by mixing two molecular proportions of aldehyde with one molecular proportion of hydrogen peroxide in ether solution,

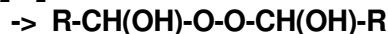

(Baeyer and Villiger, *ibid.* 1900, 33, 2486; Wieland and Wiegler, *Annalen*, 1923, 431, 310).

Peroxides from the higher aldehydes are decomposed by alkali into aldehydes and hydrogen peroxide.

The unsymmetrical dihydroxy-dialkyl peroxides do not exist; they undergo transformation into mixtures of symmetrical peroxides:

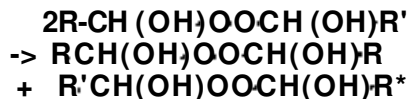

*Di(hydroxymethyl) Peroxide*,



is formed in the hydrolysis of ozonides (Briner and Schnorf, *Helv. Chim. Acta*, 1929, 12, 154), by the action of ozone on methyl ether (Fischer, *Annalen*, 1929, 476, 244) and by the action of the silent discharge on methane and oxygen (Fujimoto, *Bull. Chem. Soc. Japan*, 1938, 13, 281). It is a moderately explosive solid, m.p.  $62-64^\circ$ , and can be crystallised from ether or chloroform; but care is necessary in attempting to induce crystallisation by scratching (Wieland and Sutter, *Ber.* 1930, 63 [B], 74). It is decomposed by water into formaldehyde and hydrogen peroxide. It will oxidise sulphurous to sulphuric acid, and hydroquinone to quinone, but does not oxidise potassium iodide; reduction yields formaldehyde.

*Di(hydroxyethyl) Peroxide*,



a pungent oil, readily soluble in water, alcohol, and ether, is not highly explosive, but forms, on

keeping or warming, highly explosive diethylidene peroxide. Dehydration with  $P_2O_6$  yields "synthetic dimericbutylene ozonide,"  $C_8H_{16}O_6$ , an unstable mobile liquid which appears to form ethylidene peroxide on keeping, and yields, on distillation, monoperparaldehyde,  $C_6H_{12}O_4$ , b.p.  $45-46^\circ/12$  mm. (Rieche and Meister, *ibid.* 1932, 65 [B], 1274).

*Di(trichlorohydroxyethyl) Peroxide*,



m.p.  $122^\circ$ , is obtained from chloral and hydrogen peroxide.

*Hydroxypropyl*-, *-butyl*-, and *-taleryl peroxides* are oils; *(dihydroxyheptyl) peroxide* is a solid, m.p.  $64^\circ$ ; *di(hydroxyoctyl) peroxide* has m.p.  $72^\circ$ .

*Di(hydroxyundecyl) peroxide*, m.p.  $74^\circ$ , is a fission product of oleic acid ozonide.

### VII. Alkylidene Peroxides.

*Ethylidene Peroxide*,

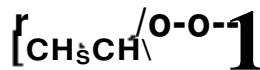

is formed by

- (1) dehydration of  $\alpha$ -hydroxyethyl hydrogen peroxide or of di(hydroxyethyl) peroxide with  $P_2O_5$  and subsequent warming, *in vacuo*, of the dehydration products;
- (2) prolonged preservation, or warming, of butylene ozonide;
- (3) autoxidation of ether (Rieche, *Z. angew. Chem.* 1931, 44, 590).

When freshly prepared it is an explosive viscous oil, but is not shock-sensitive; on keeping it becomes violently explosive and sensitive to the slightest friction. Determination of its molecular weight in benzene give values of  $x$  from 4-8 (Rieche and Meister, *Ber.* 1931, 64 [B], 2335).

*Peroxides Formed from Aldehydes and Ozone.* Ozonolysis of undiluted aldehydes at fairly low temperature gives mixtures of the corresponding acids and peracids, the former being in excess.



(Fischer, Diil], and Voltz, *Annalen*, 1931, 486, 80).-The "aldehyde peroxides"  $RCHO_2$  obtained by the action of ozone on aldehydes (Harries and Koetschau, *ibid.* 1910, 874, 321) are probably mixtures of acid, peracid, and unaldehyde.

### VIII. Di-alkylidene Peroxides,



*Di-ethylidene Peroxide*, ( $R=CH_3$ ), is a highly explosive resin formed on warming or preservation of di-hydroxyethyl peroxide (Wieland and Wiegler, *I.e.*).

*Dibenzal Peroxide*, ( $R=C_6H_5$ ), m.p.  $202^\circ$ , is obtained by oxidation of benzaldehyde with

Garro's acid (Baeyer and Villiger, *Ber.* 1900, 33, 2485).

### IX. Ketone Peroxides.

These result from the action of hydrogen peroxide on ketones.

*Diacetone Peroxide*, m.p.  $132^\circ$ , is obtained by the action of Garro's acid on acetone (Baeyer and Villiger, *I.e.*). The formula

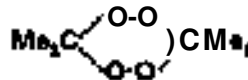

is ascribed to it.

*Triacetone Peroxide*,  $(C_8H_{16}O_6)_3$ , prepared from acetone and hydrogen peroxide, is a beautifully crystalline compound, m.p.  $98-5^\circ$ . It explodes on percussion or on heating.

Both di- and tri-acetone peroxides are products of autoxidation of di- $\alpha$ -propyl ether and their formation via hydroperoxides has been suggested (Rieche and Koch, *Ber.* 1942, 75 [B], 1016).

*Mesityl Oxide Peroxide*, m.p.  $123^\circ$  (Wolffenstein, *ibid.* 1895, 28, 2265) is formulated as a bimolecular peroxide,

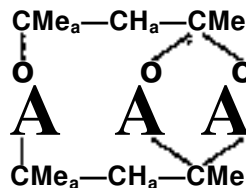

or

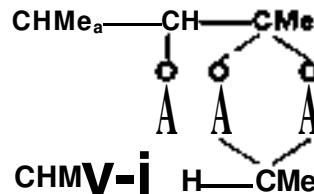

*Peroxides of Cyclic Ketones.*—The initial product of the reaction of hydrogen peroxide with a cyclic ketone is probably a 1-hydroxyhydroperoxide, *e.g.*, cyclopentanone gives

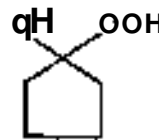

which may change spontaneously to a dimer of type

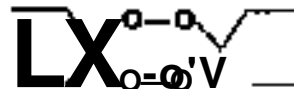

1: V-Dihydroxy-peroxides, *e.g.*,

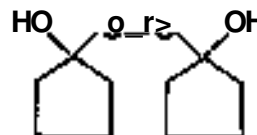

have also been isolated (Milas, Harris, and Panagiotakos, *J. Amer. Chem. Soc.* 1939, 61,



2430; Dilthey, Inckel, and Stephan, J. pr. Ghem. 1940, [ii], 154, 219).

*Ltfiwlic Acid Diperoxide*, m.p. 197° (decomp.), is a decomposition product of rubber ozonide (Harries, Ber. 1905, 38, 1195) but it is neither an aldehyde nor a peracid. Pummerer *et al.* (*ibid.* 1931, 64 [B], 804) suggest the bimolecular ketone peroxide constitution

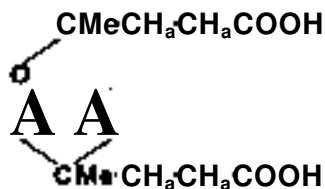

X. Polymeric Peroxides.

Autoxidation of, conjugated dienes or trienes yields polymeric peroxides (dimeric to octameric) in which stabilisation of an initially formed diradical has undoubtedly been achieved by intermolecular reaction (Farmer, Trans. Inst. Rubber Ind. 1945, 21, 122).

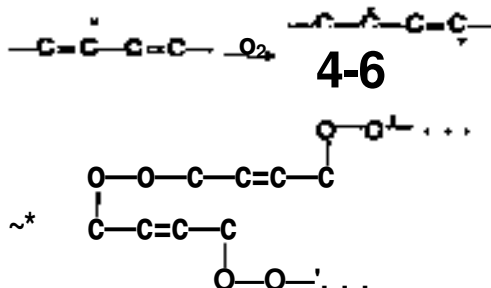

The polymeric peroxides generally exhibit high thermal and chemical stability, but a highly explosive butadiene peroxide has been reported (Scott, Ind. Chem. [News], 1940, 18, 404).

XL Acid Peroxides and the Peracids.

*Acid Peroxides*, (RCO)<sub>2</sub>O<sub>2</sub>.

These are prepared by treating acid chlorides or anhydrides in ethereal solution with barium peroxide, or by the action of the ice-cold acid chloride on sodium peroxide,

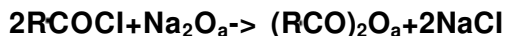

The acid peroxides are powerful oxidising agents; they undergo decomposition on heating and are hydrolysed by water to peracids and acids:

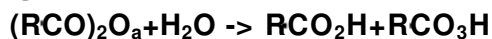

*Diacetyl Peroxide*, (CH<sub>3</sub>CO)<sub>2</sub>O<sub>2</sub>, m.p. 30°, b.p. 63°/12 mm., is very unstable. Its odour is sharp and characteristic, resembling ozone.

*Succinyl Peroxide*, C<sub>4</sub>H<sub>4</sub>O<sub>4</sub>, is a highly explosive crystalline powder obtained from succinyl chloride and sodium peroxide; *succinic peroxide*, (COOHCH<sub>2</sub>CH<sub>2</sub>CO)<sub>2</sub>O<sub>2</sub>, prepared from succinic anhydride and 7.5% hydrogen peroxide, is more stable, m.p. 124° (decomp.).

*Zibenzoyl Peroxide*, (Ph-CO)<sub>a</sub>O<sub>2</sub>, is prepared from benzoyl chloride and sodium peroxide or

hydrogen peroxide and sodium hydroxide, and is used extensively as a polymerisation catalyst and in peroxide-catalysed organic reactions. It is fairly stable, m.p. 103°, but sometimes explodes when quite dry, although this tendency can be prevented by the admixture of sodium chloride before drying. The reactions of benzoyl peroxide are mainly those of the radicals resulting from its dissociation:

1. Pyrogenic decomposition eliminates 2 mol. of carbon dioxide, (RCO)<sub>a</sub>O<sub>a</sub> → 2CO<sub>a</sub> + RR.
2. In the "RH scheme" another hydrocarbon participates in the reaction and 1 mol. of carbon dioxide is eliminated,



or  $\text{R}-\text{CO}_a\text{R}' + \text{RH} + \text{CO}_a$ ,

e.g.,  $\text{PhCl} + \text{Ph-PhCl}$ .

3. The oxygen bridge may suffer cleavage, as in hydrogenation or reaction with substances susceptible to dehydrogenation,

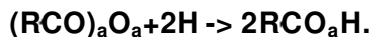

4. In reaction with water or bases in the cold it resembles an acid anhydride,

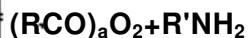

*Benzoyl Toluoyl Peroxide* and similar mixed peroxides are obtained when a mixture of different acid chlorides reacts with sodium peroxide, but acetyftenzoyl peroxide is also obtained by oxidation of benzoic acid in acetic anhydride (G.P. 637814).

*Peracids*, RCOOOH.

The aliphatic peracids are obtained by the action of ozone on aldehydes, or by treating acids or anhydrides with hydrogen peroxide and a trace of sulphuric acid or *jp*-toluenesulphonic acid (Boeseken, Bee. trav. chim. 1936, 55, 815). They are valuable oxidising agents for unsaturated substances and may be used to determine unsaturation (Smits, *ibid.* 1930, 49, 691); if conducted at low temperature the oxidation yields oxido-C<sub>9</sub>mpounds (Findley *et al.*, J. Amer. Chem. Soc. 1945, 67, 412), but at ordinary temperatures acylated diols are more usually obtained. Oxidation does not occur if the double bond is adjacent to a carbonyl group, as in crotonic acid.

*Peracetic Acid*, CH<sub>3</sub>CO<sub>3</sub>H, m.p. 0-1% explodes at 110°. It is readily soluble in water, alcohol, ether, and sulphuric acid. For its preparation, see Findley (J.c).

*Perbenzoic Acid*, C<sub>6</sub>H<sub>5</sub>CO<sub>3</sub>H, m.p. 41-43°, is best prepared by treating benzoyl peroxide with sodium ethoxide (Braun, Org. Syntheses, 18, 86). It is somewhat explosive.

THERMAL DECOMPOSITION OF PEROXIDES.

George and Walsh (Trans. Faraday Soc. 1946, 42, 94) suggest that peroxides undergo fission at the —O—O— bond, followed by fission at the weakest adjacent —C—C— linkage, the largest

of the alkyl substituents being split off preferentially. The following examples illustrate the mechanism involved:

1. *tert*-Butyl hydrogen peroxide,

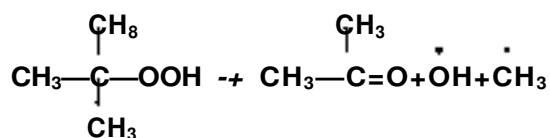

2. Di-*tert*-butyl peroxide,

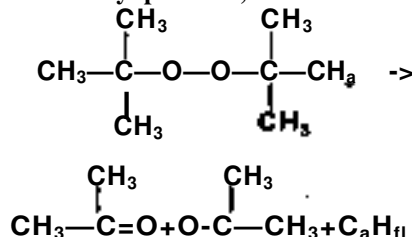

3. Benzoyl peroxide,

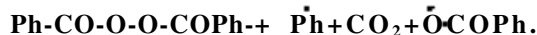

For other data on peroxide decomposition, see Wieland (Annalen, 1934, 513, 93; 1937, 532, 166), Hermans (*ibid.* 1935, 519, 133; Rec. trav. chim. 1935, 54, 760), Barak and Style (Nature, 1935, 135, 760), Harris and Egerton (Proc. Roy. Soc. 1938, A, 168, 1), Brown (J. Amer. Chem. Soc. 1940, 62, 2657), and McLure (Canad. J. Res. 1942, 20B, 103).

*Literature.*

A. Rieche and F. Hitz, "Alkylperoxide und Ozonide," Steinkopff, Dresden, 1931; A. Rieche, "Alkylperoxide und Ozonide" (a review), Angew. Chem. 1932, 45, 441.

G. F. B.

**PERSIAN BERRIES.** These are the seed-bearing fruit of various species of *Rhamnus* growing in France, Spain, Italy, the Levant, and Persia. The Persian berry proper is obtained from *R. amygdalina*, *R. oleoides*, and *R. saxatilis*, and is about the size of a pea, yellowish-green in colour, with a surface much shrivelled, hard, and divided, along well-marked depressions forming a cross, into four parts, each containing a triangular seed; its taste is intensely bitter.

Avignon or French berries, the product of *R. infectoria* and *R. alaternus*, are smaller in size than the foregoing and contain only two seeds.

Spanish, Italian, and Hungarian berries are, respectively, the product of *R. saxatilis*, *R. infectoria*, and *R. cathartica*. These are similar in quality to the Avignon berries.

All of these botanical varieties do not contain entirely the same constituents, but there is every reason to suppose that the colouring constituents of those to which the term Persian berry proper is applied are identical in each case.

Persian berries contain the glycosides of three colouring matters, quercetin, rhamnazin, and rhamnetin (Herzig, Monatsh. 1885, 6, 889; 1888, 9, 549; 1889, 10, 561; A. G. Perkin and Geldard, J.C.S. 1895, 67, 600). These substances are isolated by digesting the berries with boiling water and boiling the extract with addition of a small quantity of sulphuric acid. The glycosides are thus hydrolysed and the crude

colouring matters separate as a greenish-yellow precipitate. From this product quercetin is extracted with boiling alcohol and rhamnazin is removed from the residue by two or three extractions with boiling acetic acid.

Quercetin,  $\text{C}_{16}\text{H}_{10}\text{O}_7$ , m.p. 316-317°, is 3:5:7:3':4'-pentahydroxyflavone:

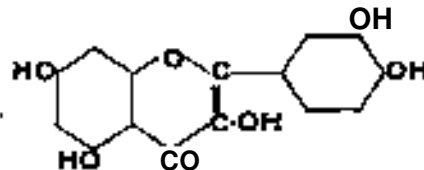

and on fusion with potash yields phloroglucinol and protocatechuic acid. Its constitution has been confirmed by synthesis [*v.* QUERCITRON BABK].

Quercetin gives red-brown, brown-orange, bright orange, and olive-black shades on wool mordanted, with chromium, aluminium, tin, and iron, respectively.

Rhamnazin,  $\text{C}_{17}\text{H}_{14}\text{O}_7$ , yellow needles, m.p. 214-215°, is a dimethyl ether of quercetin and on methylation with methyl iodide affords quercetin 3:7:3':4'-tetramethyl ether. It is hydrolysed by alcoholic potash with formation of vanillic acid and phloroglucinol monomethyl ether and is, accordingly, quercetin 7:3'-dimethyl ether. *Triacetyl*- and *tribenzoyl*-rhamnazin melt at 154-155° and 204-205°, respectively (Perkin and Geldard, *I.e.*; Perkin and Allison, *ibid.* 1902, 81, 469).

Rhamnaziit dyes mordanted wool giving shades resembling those which are produced by ksmmpferol (3:5:7:4'-tetrahydroxyflavone):

Chromium.	Aluminium.	Tin.	Iron.
Golden-yellow.	Orange-yellow.	Leinon-yellow.	Olh'e-brown.

Only a small amount of this colouring matter is present in Persian berries.

Rhamnetin,  $\text{C}_{16}\text{H}_{12}\text{O}_7$ , yellow needles, m.p. above 300°, yields quercetin 3:7:3':4'-tetramethyl ether when methylated with methyl iodide, and is hydrolysed by boiling aqueous or alcoholic potash with the production of protocatechuic acid and phloroglucinol monomethyl ether (Herzig, *I.e.*; Perkin and Allison, *I.e.*). It is, therefore, quercetin 7-methyl ether.

*Tetra-acetyl*rhamnetin, m.p. 190-192° (Oesch and Perkin, *ibid.* 1914, 105, 2354), *tetrapropionyl*-rhamnetin, m.p. 158-162° (Liebermann and Hörmann, Annalen, 1879, 196, 320), and *rhamnetin sulphate*, orange-red needles (Perkin and Pate, J.C.S. 1895, 67, 650) have been prepared.

Rhamnetin is a strong dyestuff and gives on mordanted woollen cloth shades which are practically identical with those produced by quercetin (Perkin and Wilkinson, *ibid.* 1902, 81, 590).

Xanthorhamnin,  $\text{C}_{34}\text{H}_{42}\text{O}_{20}$ , aglycoside of rhamnetin, is obtained by extracting Persian berries with alcohol (Gellatly, Edin. New Phil. Jour. 1858, 7, 252; Liebermann and Hörmann, *I.e.*). When hydrolysed by means of its specific ferment, *rhamninase*, which is present in Persian berries, xanthorhamnin forms rhamnetin and

the complex sugar *rhamnose*, C<sub>18</sub>H<sub>32</sub>O<sub>14</sub>; the latter, on digestion with boiling dilute acids, is converted into 2 mol. of rhamnose and 1 mol. of galactose (C. and G. Tanret, Compt. rend. 1899, 129, 725). Methylation of xanthorhamnin with excess of diazomethane and hydrolysis of the yellowish-brown resinous product with acid yields. 3-hydroxy-5:7:3':4'-tetramethoxyflavone indicating that the rhamnose residue is in union with the 3-hydroxyl group (Attree and Perkin, J.C.S. 1927, 234).

No glycosides of rhamnazin or quercetin have been isolated as yet from Persian berries.

*Persian berry extract* was at one time prepared in large quantity by extracting the berries with boiling water and evaporating the solution under reduced pressure.

**Dyeing' Properties.**—With tin mordant, Persian berries give bright yellows and oranges which are only fairly fast to light, but, according to Hummel, the yellowish-olive produced with copper mordant is extremely fast and is darkened rather than otherwise by exposure'. Persian berries, as a rule, give redder shades than quercitron bark, a fact which is to be explained as due to the hydrolysis of the glycosides by the ferment uhamninase, for the quercitrin of quercitron bark is not accompanied by such a specific ferment, and consequently gives yellower shades. The action of rhamninase can be employed to distinguish between the dyeing properties of the glycosides contained in the berries and the free colouring matters produced by their hydrolysis. Thus, if Persian berries are added to a cold dyebath and this is slowly heated to boiling the glycosides are hydrolysed by the ferment; but if the berries are plunged into boiling water, the ferment is destroyed and a solution of the glycosides is obtained. In the former case wool mordanted with tin gives an orange-red shade, whereas in the latter a pure yellow is produced.

Persian berries were formerly used to a considerable extent in calico-printing for the formation of yellow, orange, and green shades.

E. J. C.

**PERSIMMON.** An apple-like fruit said to have originated in China, and now grown in considerable quantities in both North and South America. Two principal species are distinguished, the American, *Diospyrus virginiana* and the Japanese persimmon or Kaki, *D. kaki* or *D. chinensis*.

The *American* persimmon is somewhat smaller than the Asiatic varieties and, owing to its extremely astringent flavour, is allowed to become fully ripe before being eaten.

According to Bigelow *et al.* (J. Amer. Chem. Soc. 1906, 28, 688), the fruit averaging 6-20 g. in weight has the following percentage composition:

Solids.	Protein.	Acids (as malic).	Reducing sugars.	Tannin.	Fibre.	Ash.
27.3	1.1	0.5	16.3	2.1	1.0	0.7

A mineral analysis of the fruit is given by

Troop and Hadley (Indiana Agric. Exp. Sta. 1896, Bull. 60):

	Percentage of total ash.				
	K <sub>2</sub> O.	Na <sub>2</sub> O.	CaO.	MgO.	Fe <sub>2</sub> O <sub>3</sub> .
Pulp . .	67.1	8.2	6.0	2.8	0.7
Seed . .	38.6	8.2	6.9	7.1	1.2

	Percentage of total ash.				
	Mn <sub>2</sub> O <sub>3</sub> T.	P <sub>2</sub> O <sub>5</sub> .	SO <sub>3</sub> .	SiO <sub>2</sub> .	Cl.
Pulp . .	0.08	9.1	8.6	1.8	0.4
Seed . .	0.10	13.7	10.8	2.06	0.1

Analyses of the *Japanese* kaki show considerable variation but the following due to Gore (U.S. Dept. Agric. Bur. Ghem. 1911, Bull. 141) is the mean of a number of samples:

Solids.	Protein.	Acids.	Reducing sugars.	Tannin.	Ash.
21.5	0.6	0.14	15.5	0.77	0.5

All varieties contain glucose, fructose, and sucrose as principal sugars. There are small proportions of pentosans and pectin. Astringent varieties contain relatively larger amounts of tannin which, however, decrease during ripening, the associated physiological changes being a subject on which very divided opinions have been expressed (*see* Kumagai and Tazaki, J. Sci. Agric. Soc. Japan, 1912, 236, 347, and Davis and Church, J. Agric. Res. 1931, 42, 165).

Persimmons contain appreciable amounts of ascorbic acid, 30-50 mg. per 100 g. being reported. Leaves contain about ten times this quantity and yield a medicinal "tea."

A. G. Po.

PpRUVIOL (v. NEBOLIDOL, Vol. VIII, 461(2).

PERVITIN (v. "METHEDRINE," Vol. VIII, 4d).

**PEST CONTROL.** The total annual economic loss for which insect and other pests are responsible is so colossal that, if it could be computed with any degree of accuracy, its expression in figures would convey little to the mind. It is a problem of great antiquity, as is evidenced by the story of the locust plagues of Egypt and the fact that Pliny gave a series of control measures against cereal diseases in A.D. 77, but it is only in relatively recent years that the problem has been approached scientifically.

From the point of view of control, pests can most conveniently be described under the following arbitrary heading?\*

**Disease-carrying Arthropods.**—Amongst the most important disease vectors are the mosquito (*Anopheles*, *Mdes segypti*, carrying malaria; genera *Mdes*, *Mansonia*, *Psorophora*, and *Wyomyia*, Urban and Jungle Yellow Fever; *JSdes segypti* and *A. albopictus*, dengue; culicine, anophetine and aedine species, filariasis); the louse (*Pediculus humanus*, typhus group of Rickettsial diseases and European relapsing

fever); the tick (*Ixodida*, spotted fever group of Ixodidae); the Bickettsial diseases; *Ornithodoros hermsi* and *turicata*, U.S. and African relapsing fever); the mite (*Trombicida ahamushi* and *deliensis*, tsut-sugamushi fever and scrub typhus); the flea (*Xenopsylla chespi*, plague); the sandfly, (*Phlebotomus argentipes*, major var. *chinensis* and *sergenti*, sandfly fever, Leishmaniasis); and the tsetse fly (*Glossina palpalis* and *morsitans*, Trypanosomiasis).

The most dangerous insect transmitters of human bacterial diseases in Great Britain are the various species of carrion fly, through the intestinal canal of which are able to pass unaltered, within certain limits, most of the pathogenic bacteria, fungi, and protozoa that infect man.

It is impossible to assess the damage caused by any one of these arthropods, but some idea is gained from the fact that the world death-rate from mosquito-transmitted malaria has been estimated as two million annually, that the 20,000,000 hospitalisation cases per year in India and the annual economic loss to the British Empire alone as a result of this disease is in excess of £50,000,000.

Stored-food Pests.—The loss due to the depredations of insect pests on the world's cultivated crops alone, amounts to hundreds of millions of pounds sterling annually.

The number and variety of these insects is so great that it is impossible to record them in full here; for further details reference should be made to the numerous Ministry of Food publications on the subject (H.M. Stationery Office), and A. Mallis, "Handbook of Pest Control," MacNair-Dorland Co., 1945.

Amongst the more common stored food pests are: Beetles (Coleoptera); moths (Lepidoptera); the rice weevil (*Sitophilus oryzae*); saw-toothed grain beetle (*Oryzophilus surinamensis*); Cadelle or bread beetle (*Tenebroides mauritanicus*); lesser grain borer (*Rhizopertha dominica*); tobacco beetle (*Lassoderma servicum*); the bean weevils (*Acanthus celidus* and *Urosobruchus*); dried fruit beetle (*Carpophilus hemipterus*); the flour beetles (*Tribolium confusum* and *castaneum*); the meal worms (*Tenebrio molitor* and *obscurus*); Mediterranean flour moth (*Ephestia kuehniella*); dried-fruit moth (*Plodia interpunctella*); and the Angoumois grain moth (*Sitotroga cerealella*).

Agricultural and Horticultural Insect Pests\*.—These, again, are so many and varied that it is impossible to list them in full here. Most insect orders have many representatives which have to be treated as agricultural, horticultural or forest pests, examples of which are as follows:

*Coleoptera*, Colorado beetle, apple blossom weevil, wood borers.

*Diptera*, onion and carrot flies.

*Hemiptera*, leaf hoppers, chrysanthemum aphids.

*Hymenoptera*, wasps, pine saw flies.

*Lepidoptera*, codling moth, cabbage butterfly, spruce bud worm.

*Orthoptera*, crickets, grasshoppers.

*Thysanoptera*, onion and citrus thrips.

In addition to the insect pests, there are the arachnids, typical of which are the red spider, citrus red mite, and the ticks.

Household Insect Pests.—In Great Britain, the principal representatives of the group are: the house fly (*Musca domestica*); stable fly (*Stomoxys calcitrans*); And blow-fly (*Campophoridae* and *Lucilia*); fire roaches (*Blattida*); bedbugs (*Cimex lectularius*); the human fleas (*Pulex irritans*); the spiders (*Theridion tepidarorum*); the clothes moths, principal of which is the webbing clothes moth (*Tineola bisetella*); wasps (*Vespulae*); and ants, which, whilst not true household pests, may become very annoying when they establish their nests in close proximity to the house.

Rodents.—The remarkable ability of the rat to adapt itself to every environment, its great fecundity, and its habitual cunning, have made it one of the most prolific and harmful species of pest known. Rats are extremely destructive in attacking farm stock, feeding on stored grain, and gnawing hard substances to maintain their incisors at proper length, but these depredations are of minor importance compared with the havoc wrought by such diseases as the various forms of plague, bubonic, septicemic, pneumonic, and typhoid, and typhus, which the rat helps disseminate.

The rodents best known to the pest controller are the brown rat (*Rattus norvegicus*), the black rat (*Rattus rattus*), and the house mouse (*Mus musculus*), but hundreds of different species and sub-species are encountered all over the world, e.g., the tree grey and red squirrels (*Sciurus griseus* and *douglasii*), pocket gophers (genus *Thomomys*), ground squirrels (genus *Erethicus*), moles (genus, *Scapanus*), muskrats (*Ondatra zibethica*), and rabbits (*Lepus* and *Sylvilagus*).

## METHODS OF PEST CONTROL.

### INSECTS.

The control of injurious flying and crawling pests, popularly termed insects, in the disease-carrying and agricultural categories, is usually attempted by using one or more of the general methods based on (a) biological, (b) mechanical, or (c) chemical techniques,

#### (a) Biological Control.

This form of control, which is applicable mainly to the eradication of agricultural pests, may be defined as the encouragement of beneficial organisms already existing in the locality and the introduction of new species of beneficial organisms to that locality. The principles involved are discussed in detail in H. L. Sweetman, "The Biological Control of Insects," Ithaca, New York, 1936, and typical examples are discussed below.

With the higher animals, the scope of biological control is limited entirely to the encouragement of those which are beneficial because of their influence upon injurious organisms. Insectivorous birds are of considerable importance in establishing the natural balance of insects, as is evidenced by the fact that it has been found in the United States that 30 kinds of birds feed on the codling moth; in

some localities it being estimated that 66-85% of the hibernating larvae are destroyed by this means.

Plant protection by means of predator insects has far greater scope, and whilst it is by no means universally applicable, this method has been most successful in many instances. The classic example is the control of the fluted scale (*Icerya purchasi*) which, towards the end of the nineteenth century, threatened the entire citrus industry of the Pacific coast of North America, by the introduction from Australia of its natural enemy, the ladybird beetle (*Novius cardinalis*).

Whilst the method has been equally successful elsewhere, e.g., the control of the sugar cane frog-hopper by the Amazon fly in British Guiana, and the elimination of *Promecotheca reichi* from Fijian coconut palm groves by the introduction of *Pleurotropis parvulus* from Java, it is often difficult to accomplish because of weather and feeding conditions, which are adverse to the introduced predator.

The use of the surface-feeding minnow, *Oambusia*, to control Anopheline mosquito larva, has met with considerable success under favourable conditions. A striking instance of its power is recorded from thirty-two villages on the coast of New Ireland in Australia where *Oambusia* were introduced into all known Anopheline breeding grounds, and the spleen rate (index of malaria incidence) then compared with those of thirty-five other villages not so treated.

Average spleen rates.	Aug. 1930.	Feb. 1931.	Oct. 1931.	July 1932.
32 <i>Oambusia</i> treated villages . . . . .	21.6%	16.8%	12.8%	4.2%
35 untreated villages . . . . .	47.1%	23.9%	24.7%	28.8%

Moreover, for the first time on record, there was an excess of human births over deaths in the treated villages.

The use of parasitic fungi and bacteria has been examined extensively and their importance as factors in the natural control of insects has been the subject of frequent controversy. Whilst the former appears to be capable of useful application under limited conditions, the latter does not appear to have met with much success.

(6) Mechanical Control.

This form of control is best exemplified by citing its utilisation in mosquito and (later) rodent control. The essence of mechanical control in the former case is "water management" in the broadest sense, i.e., alterations to make it unsuitable for Anopheline breeding. Anophelines in general breed in clear water and different species show preference for varying degrees of stagnation or flow, or shade or sunshine, or other factors such as salinity.

Detailed examples of the use of such methods are recorded in R. Svensson, "A Handbook of Malaria Control," London, 1940, the following examples being typical.

*Alteration of Salinity.*—Mainly applicable in coastal regions, e.g., the reclamation of land in the Zuyder Zee area of North Holland converted brackish dykes into fresh, thus causing the local malaria vector, *A. maculipennis*, to be replaced by a non-malaria carrying type. The draining of the Pontine marshes in Italy resulted in the almost total elimination of malaria locally. Conversely, the changing of a brackish marsh at Durazzo, Albania, into a salt water lagoon resulted in the elimination of the local carrier, *A. elutus*. >

*Alteration of Larval Food Supplies.*—The periodic emptying and drying of sea-water fish ponds on the coast of Java eliminated the thick surface growth of green alga, which supported both *A. sundaicus* and fish, and promoted the bottom growing blue-green algae which provided neither shelter nor food for the larvae but abundant nourishment for the fish.

*Alteration of Light and Shade.*—The planting of suitable thick growing shrubs along the banks of narrow streams, and the encouragement of a dense growth of vegetation in swamps, have met with great success in Assam and Ceylon against the sun-loving *A. minimus* and *A. culicifacies*.

*Regulation of Water Flow or Level.*—This is accomplished either by irrigation, "flushing" of streams, damming of swamps unsuitable for draining, and the converting into fresh water lakes, or "training" of streams into new beds with elimination of stagnant pools; the latter method, in conjunction with "oiling," was the most regularly employed method of malaria control used up to the outbreak of the Second World War. Whilst expensive, it is, if properly applied, an effective and efficient method of control, outstanding examples of its successful application being the building of the Zambesi Bridge and the Singapore Naval Base, and the cutting of the Panama Canal, all in highly malarious regions.

Other control methods, which may be classified as "mechanical," are the elimination of agricultural pests by hand picking, when labour is cheap, such as the hand collection by children of the larvae and adults of the large Cabbage White butterfly (*Pieris brassicae*), and the eradication of the host plant when other methods of control are inappropriate. This latter method was successfully used in the eradication of the Mediterranean fruit-fly (*Geratitits capiata*) from Florida in 1929 although it involved the destruction, of over half a million boxes of grape fruit and cost the Federal Government over \$1,250,000.

(c) Chemical Control.

Chemicals utilised in the control of insects either in the larval, pupal or adult stages, are termed "insecticides," and have for many years been divided into two types, i.e., stomach or contact poisons, depending on whether they are absorbed by the insect by ingestion or solely by external contact. More recently, a third type, the fumigants, has become important. Stomach poisons and contact insecticides are separated on the basis of the feeding habits of the insects, the first being used against chewing insects and the latter against the sucking species. Fumigants

act in the gaseous state through the respiratory system.

#### *Stomach Insecticides.*

These are usually compounds that are relatively insoluble in water and consequently unable to penetrate plant tissues in amounts great enough to cause injury. In order to kill the insect, however, they must be soluble to a certain extent. The most widely used stomach insecticides are the arsenicals (Paris Green, the arsenites, and lead, calcium, and other inorganic arsenates) and fluorine compounds (fluorides, fluorosilicates, and fluoroaluminates). *Paris Green* (Schweinfurter Grün) is a micro-crystalline powder, usually described as copper acetoarsenite, for which the formula



proposed by Ehrmann in 1934 is usually accepted. Provisionally used as a green pigment, it first came into use as an insecticide in 1867, when it was successfully employed against the Colorado beetle in the eastern parts of the U.S.A. It was applied as a dust, mixed with several parts of flour or ashes as extender. It was later used against the codling moth, a use which continued until 1900. Its principal use prior to the war was as a mosquito larvicide, its use being limited mainly to surface-feeding Anopheline larvae; it was applied at the rate of 1 lb. per acre to the water surface as a dust diluted with some inert substance to a strength of 2-5% for large areas and 1% for small areas. In shallow breeding places, aqueous suspensions of Paris Green have been found effective.

Paris Green was originally made from verdigris, and the older Paris Greens were consequently of varying composition. The methods of preparation are now fairly well standardised and the insecticides now produced contain at least 55% total arsenious oxide, at least 30% cuprous oxide, and at least 10% acetic acid, and have a definite degree of fineness and a limit to the water-soluble arsenic content.

**Arsenites.**—Sodium, calcium, and zinc arsenite have been used in the U.S.A. and Russia to a certain extent to control crickets, potato beetles, grasshoppers, and forest insects. Certain other arsenites have had some popularity, e.g., *Scheele's Green* (acid copper arsenite), was introduced as a substitute for Paris Green in 1875, whilst *Jjondon Purple* (crude calcium arsenite-arsenate mixture obtained as a by-product of magenta production) had a similar use for a short time.

**Arsenates.**—In general, these are less active insecticides than are the arsenites, but they are more stable and consequently safer to use upon living plants. This safety factor is largely responsible for the recent tremendous increase in the use of calcium and lead arsenates, whilst the consumption of arsenites, including Paris Green, has remained static. Lead arsenate is the best known and most extensively used of all stomachy poisons, its principal use being against codling moth in apple orchards. The annual American consumption in 1934 was estimated as being 20,000 tons.

The lead arsenate most commonly used for insecticidal purposes and described in America as "acid" arsenate, approximates in composition to  $\text{PbHAsO}_4$ , and is made by the interaction of lead nitrate or acetate and disodium hydrogen arsenate. The chemistry of the lead arsenates has been studied in detail by McDonnell and Smith (J. Amer. Chem. Soc. 1916, 38, 2027, 2366; 1917, 39, 937) and an adequate summary is given in H. Shepard, "Chemistry and Toxicology of Insecticides," Minneapolis, 1945.

**Calcium Arsenate.**—Although, the use of lead arsenates as insecticides has met with greater success, the lead ion appears to play no important role, and the desire to replace it by a lighter and less poisonous metallic radical, led to the development of calcium arsenates free from water soluble arsenic compounds. Its first recorded use, on a large scale was in 1919, about 1,500 tons being used in controlling the cotton-boll weevil in the U.&A. The estimated American consumption in 1934 was 15,000 tons per annum, as compared with 20,000 tons of lead arsenate, although it has never seriously competed with the latter in codling moth control. Objections raised to its use are that it is more likely to cause arsenical injury, it appears to be less effective than the lead salt and hydrolyses more readily, against which it has the advantage of being cheaper to make and transport, and there is less risk of cumulative poisonous effects from its use.

The chemistry of the calcium arsenates is in many ways similar to that of the lead salts. It was at one time thought that besides the dicalcium hydrogen arsenate,  $\text{CaHAsO}_4$ , there existed a definite tricalcium salt,  $\text{Ca}_3(\text{AsO}_4)_7$ . Later work showed this to be unlikely and proved that, as with the lead arsenates, there is probably a continuous series of basic calcium arsenates. In contrast to the lead salts, dicalcium hydrogen arsenate is too soluble for safe application to foliage; the commercial calcium arsenates are therefore prepared to contain an excess of lime, and consequently consist of mixtures of indefinite basic calcium arsenates and calcium hydroxide. The lead arsenates form admirable spray suspensions, but the dry salts do not reform the excellent suspensions given by the pastes. The basic calcium arsenates afford an excellent powder which finds important application as a dust, notably against the cotton-boll weevil. The lead arsenates are therefore of greater value as sprays, the calcium salts as dusts.

**Fluorine Compounds.**—The earliest recorded use of fluorine compounds for insect control is in B.P. 8236 dated 1896. Although not considered in plant protection for many years, sodium fluoride gradually came into use as a roach poison. As it is moderately soluble in water, the risk of phytocidal action and rapid removal by rain, prohibits its use on foliage. For this reason the silicofluorides and aluminofluorides have tended to take its place, but the use of inorganic fluoro-compounds as insecticides has been arrested by the discovery that, although they do not have the acute toxicity to warm blooded animals of the arsenicals, they have serious deleterious effects in that slight traces in

drinking water have been proved to produce mottling of the teeth.

**Miscellaneous Stomach Insecticides.**—Of the many and varied compounds tested in an endeavour to find an effective stomach poison of low toxicity to Warm blooded animals, few have successfully passed the laboratory stage. The following have all shown promise, but with few exceptions have not seen full-scale use, usually because of expense, phytocidal activity or instability: the ground rhizome of White Hellebore, lead chromate, cuprous thiocyanate, Reinecke's salt, alkyl and aryl phosphonium salts, and triphenyl phosphine.

Limited, but definite, uses have been found for cuprous cyanide (as a mosquito larvicide), dinitro-*o*-cresol (2:4-dinitro-6-methylphenol) (as an ovicide), phenothiazine<sup>^</sup>thiodiphenylamine or dibenzo-1:4-thiazine) and the explosive sulphur nitride S<sub>4</sub>N<sub>4</sub>·Q

#### Contact Insecticides.

Prior to the recent discovery of the stable organic insecticides, D.D.T., Gammexline, and 1068, the plant derivatives, nicotine, pyrethrum, and rotenone were the most extensively used insecticides in this category. These, together with the sulphur and copper compounds and the hydrocarbon oils covered a wide field of requirements,

Nicotine (v. Vol. VIII, 477c) is an alkaloid, which when pure is a mobile, colourless liquid, boiling at 247°c. On ageing, it turns brown and becomes more viscous. It is water soluble, has a disagreeable odour, is appreciably volatile, and may be steam distilled. It appears on the market both in the free state and as the sulphate, sold under the name "Black Leaf 40" containing 40% of the base.

Nicotine is used mostly as a contact spray for the control of soft-bodied insects such as plant lice and codling moth. A bibliography on the insecticidal use of nicotine and tobacco has been published by McIndoo, *et al.* (U.S. Department of Agriculture, E-392, 1936). Nicotine is toxic to man, the median lethal dose being about 40 mg.

The base itself acts principally as a fumigant, the active agent apparently being nicotine vapour which passes into the trachea of the insects and paralyzes the nervous system. That its greater volatility is not the only factor responsible for the high toxicity of nicotine compared with that of its salts, is evidenced by the fact that in solution the base is 5-7 times as toxic to mosquito larva as the sulphate or hydrochloride.

The need for a non-residual substitute for lead arsenate in codling moth control has prompted research on the use of nicotine and its salts as a semi-permanent stomach poison. For this purpose, volatility is a disadvantage and nicotine has been "fixed," either by absorbing it on bentonite or peat or using it in the form of its tannate. The use of penetrants in nicotine sprays is beneficial, and of those suggested for use, soap is most frequently employed, as not only is it an efficient spreading and penetrating agent, but it also has insecticidal properties

itself. The use of soaps derived from nicotine itself as a base does not appear to have found practical utilisation. Dusts, prepared by the adsorption of nicotine or its sulphate upon finely divided carriers, have been used since 1917. Inert carriers such as gypsum or sulphur are to be preferred to "colloidal" vehicles such as kaolin, kieselguhr, or talc. These have replaced the tobacco dusts previously used.

**Compounds Related to Nicotine.**—A considerable number of compounds, related to nicotine in structure,<sup>o</sup> have been examined in an endeavour to find a synthetic substitute and also in an attempt to determine the cause of the high toxicity of nicotine. Whilst pyridine and pyrrole were found by Tattersfield and Gimingham (Ann. Appl. Biol. 1927, 14, 217) to be less toxic than their hydrogenated products, piperidine and pyrrolidine, the component nuclei of nicotine, none of these four compounds approached nicotine in insecticidal activity. Richardson and Shepard (J. Agric. Res. 1930, 40, 1007) tested a number of pyridine and pyrrolidine derivatives as contact sprays against *Aphis rumicis*, and although all the compounds examined were toxic, only those the structure of which closely approached that of nicotine had comparable insecticidal value, viz.:

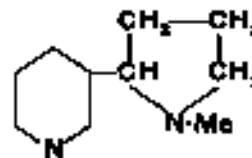

Nicotine, 0-0003.

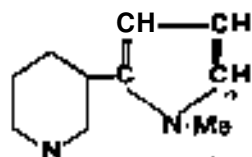

Nicotyzins, 0-004.

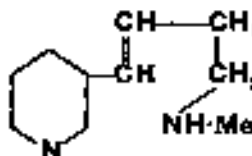

Metanicoline, 0-005.

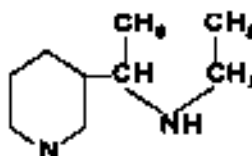

Ethyl-a-(3-pyridyl)ethylamine, 003.

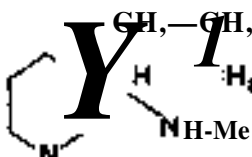

Methyl-a-(0-pyridyl)butylamine, <0-5.



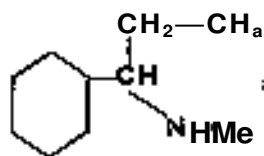

Methyl-α-phenylbutylamine, 0-5.

The numbers refer to the concentration required to till 50% of an aphid population under defined conditions of test. Tattersfield and Gimmingham (*I.e.*), Macht and Davis (*J. Pharm. Ezp. Ther.* 1934, 50, 93), Smith *et al.* (*J. Econ. Entomol.* 1930, 23, 863), and Hixon and Johns (*J. Amer. Chem. Soc.* 1927, 49, 1786) have studied the toxicity of nicotine, pyridine, piperidine, and comparable compounds.

**Pyrethrum.**—Pyrethrum has been important commercially longer than most insecticides, the first reported manufacture on a large scale being that of the Armenian, Juntikoff, in 1828. *Pyrethrum* is a subdivision of the genus *chrysanthemum* in the family Composite, and to-day is mainly derived from *C. cinerariifolium* Trev, the main producing areas being Dalmatia, Japan, and Kenya, although Brazil started producing in quantity in 1938.

Formerly, pyrethrum was applied in dust form, obtained by straight grinding of the dried flowers, and although it is still used to a certain extent in this way against roaches, bedbugs, and similar pests, its main outlet now is in solution as household, or horticultural, sprays. For this latter purpose, importation into America in 1938 amounted to 6,000 tons. The solvents normally employed for extraction of the flowers are kerosene for the dilute household sprays and chlorinated hydrocarbons for the production of the more concentrated types.

Drying under controlled conditions does not greatly reduce the pyrethrin content of pyrethrum flowers, although pyrethrum powders and dusts exposed in thin layers to air and sunlight rapidly lose activity due to oxidation. The addition of such anti-oxidants as resorcinol and pyrogallol retards such loss of activity.

Pyrethrum acts with startling rapidity upon the insect and in the case of *Musca domestica*, Richardson (*J. Econ. Entomol.* 1931, 24, 1098) was able to use the speed of paralytic action as a measure of toxicity of pyrethrum extracts. Death is believed to be caused by the destruction of the cells of the central nervous system. It is not a stomach poison and is non-toxic to warm-blooded animals.

The nature of the active principle has been investigated by Staudinger *et al.* (*Helv. Chim. Acta.* 1924, 7, 177, 201, 212, 236, 245, 377, 390, 406, 442, 448), by West (*J.C.S.* 1944, 51, 239, 642), and by Haller and La Forge and co-workers (*J. Amer. Chem. Soc.* 1936, 58, 1061, 1777; *J. Org. Chem.* 1938, 2, 646; 1944, 9, 242; 1945, 10, 106, 222; *J. Amer. Chem. Soc.* 1947, 69, 186, 979), and has been shown to consist of two types of esters, Pyrethrins I and II. The acid portions of these esters are the cyclopropane compounds (I) and (II), respectively, but the alcohol portions are not homogeneous, and appear in each case to consist of a mixture of pyrethrolone (III);

$R=CH_2:CHCH:CHCH_2-$ ) and cinerolone (III;  $R=CHjCH:CHCH_2-$ ).

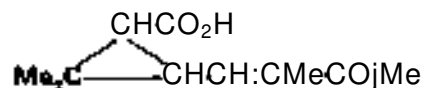
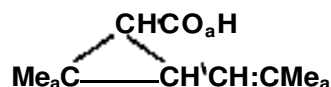

II.

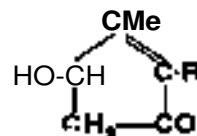

III.

, Methods of chemical assay, which include the Staudinger and Harder (1927) "acid method," modified by Tattersfield *et al.* (1929, 1931) and Seil (1934), the "methoxyl method" of Haller and Acree (1935), the "copper reduction method" of Gnadinger and Cove' (1929), and Wilcoxon's "mercury reduction method" (1936) are compared and criticised by Martin (*J. Agric. Sci.* 1938, 28, 456). Whilst chemical methods were still inadequate for testing purposes, many biological methods were proposed, the most important being the Peet-Grady chamber method (*J. Econ. Entomol.* 1928, 21, 612) involving the spraying of adult houseflies with petroleum-base pyrethrum preparations.

Pyrethrin II has a more rapid paralytic action (knockdown; but a lower insecticidal effect than Pyrethrin I in general, although the relative toxicity of the two pyrethrins has been shown to depend upon the physical condition in which they are applied.

**Rotenone and Related Compounds** (*v.* Vol. III, 5596; VII, 144<sup>^</sup>).—Rotenone is a poisonous plant principle occurring in certain leguminous plants, especially in the roots, and was used as a fish and arrow poison long before its use as an insecticide was first suggested by Oxley in 1848.

*Derris eUiptica* and *D. malaccensis* cultivated in British Malaya and the Dutch East Indies, were, until recently, the most important sources of rotenone compounds, 700 tons of crude derris root being produced from these areas in 1938. South American sources of rotenone and related extractives have been developed recently, chiefly the cube\* of Peru, and the timbo of Brazil, U.S. imports totalling over 1,000 tons in 1938. These are roots of plants of the genus *Lonchocarpus*, principally *L. utiles* and *L. urucu*, which contain up to 10% rotenone and 20% total extractives.

Rotenone,  $C_{23}H_{22}O_6$ , is extracted from the finely ground roots by means of ether, chloroform or carbon tetrachloride, and when pure has m.p. 163°C. Its molecular structure was determined almost simultaneously by Haller and La Forge (*J. Amer. Chem. Soc.* 1932, 54, 810), Robertson (*J.C.S.* 1932, 1380), Takei *et al.* (*Ber.* 1932, 65 [B], 1041), and Butenandt and

McCartney (Annalen, 1932, 494, 17). Deguelin, teptrosin, toxicarol, and sumatrol, which are closely related in structure but less toxic, also occur naturally with or in place of rotenone and are similarly obtained by extraction (*v. Vol. III, 559*).

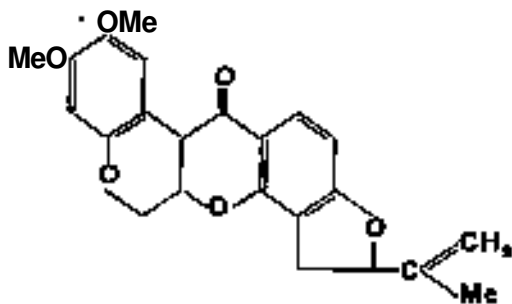

Most methods developed for the estimation of rotenone (*c. Graham, J. Assoc. Off. Agric. Chem. 1939, 22, 408*) involve extraction and crystallisation after removal of the crystallisation inhibitor, toxicol, and are modifications of the method developed by Jones (*Ind. Eng. Chem. [Anal.], 1933, 5, 23*). Colorimetric methods have been suggested (*Grose and Smith, J. Assoc. Off. Agric. Chem. 1934, 17, 336*; *Goodhue, ibid. 1936, 19, 118*) to which both rotenone and aeguelin react, and chemical methods depending upon the determination of the "afehydro" derivatives. *Tattersfield (Ann. Appl. Biol. 1939, 26, 365)* has reviewed the biological methods of assessment. Although these methods have, in general, proved inadequate, determination of the rotenone content by crystallisation, together with an assessment of the total extract, has survived in commercial practice.

The solubility of rotenone in a number of solvents has been determined by Jones and Smith (*J. Amer. Chem. Soc. 1930, 52, 2564*):

SOLUBILITY OF ROTENONE IN VARIOUS SOLVENTS AT 20°O.

Solvent	g. per 100 ml. of solution.
Chloroform . . . . .	47.2
Ethylene dichloride . . . . .	33.1
Trichloroethylene . . . . .	16.5
Chlorobenzene . . . . .	13.5
Ethylene chlorohydrin . . . . .	11.4
Benzene . . . . .	8.0
n-Dichloroethyl ether . . . . .	7.5
Acetone . . . . .	6.6
Toluene . . . . .	6.4
n-Propyl formate . . . . .	6.0
Ethyl acetate . . . . .	4.8
Xylene . . . . .	3.4
Acetic acid . . . . .	2.4
Amyl acetate . . . . .	1.6
Carbon disulphide . . . . .	1.6
Carbon tetrachloride . . . . .	0.6
Diethyl ether . . . . .	0.4
Ethyl alcohol . . . . .	0.2
Methyl alcohol . . . . .	0.2

Derris and *Lonchocarpus* are used mainly against agricultural and horticultural pests in

the form of dusting powders, aqueous suspensions, and extracts. The strength of the dust depends upon the pest to be controlled, but usually varies between 0.5 and 1.0% of derris extract. Impregnated dusts are used extensively in the U.S.A. The aqueous suspensions are made up from finely ground root mixed with a spreading agent ready for the addition of water. Extracts are usually marketed in an organic solvent such as pine oil, together with a dispersing agent.

Although nicotine, pyrethrum, and rotenone compete with each other to some extent, they should really be regarded as complementary, as in many cases they are specific in action. In general, nicotine acts quickly and little recovery ensues; pyrethrum also acts rapidly but considerable recovery often takes place; rotenone acts slowly but without much recovery even at low concentrations.

The M.L.D. for rotenone has been determined by oral, subcutaneous, intramuscular, intravenous, and intraperitoneal administration to a number of warm-blooded animals (*c. Haag, 1937*), from which it is deduced that 0.56-21 g. of derris might be taken daily by a 70 kg. man without serious injury.

Rotenone, like pyrethrum, loses its activity by exposure to the air.

Hydrocarbon and Other Oils.—Saturated, unsaturated, and aromatic hydrocarbon oils all find use as spray materials, as also do vegetable and animal oils and coal tars and their derivatives. Phytocidal factors limit the type of hydrocarbon oil, suitable for application to foliage, to oils of high percentage unsulphonated residue and of not too high viscosity.

First mention of the use of petroleum oils as insecticides was as early as 1787, but it was not until 1865 that a petroleum distillate, kerosene, was first used against scale insects on orange trees. As a dormant and a summer spray, crude petroleum oils have been used in emulsion form. The variability in properties of such oils and frequent damage to plants led to their replacement by refined oils. Kerosene as normally prepared is composed mainly of paraffin hydrocarbons with from 10 to 16 carbon atoms, and although it has been used as a spray in emulsion form, it is most widely employed as a solvent for pyrethrins. As an agricultural insecticide it has been largely replaced by more viscous, less volatile oils; of these the "light" oils of viscosity\* between 40 and 60 sec. Saybolt have been used in emulsion form for summer spraying in the U.S.A. and the "medium" oils (65 to 85 sec. Saybolt) for winter. These oils are highly refined and are almost entirely made up of saturated hydrocarbons with 14-18 carbon atoms. In general, insecticidal efficiency increases with the boiling range of the oil. Heavy oils, having a viscosity greater than 85 sec. Saybolt, are used principally as dormant sprays and for this purpose need not be so highly refined. These are also applied as emulsions and their toxicity is sometimes increased by the addition of more active insecticides/

For application to foliage, oils, besides having the correct boiling or viscosity range, should be capable of forming an emulsion of stability

sufficient to enable a spray of uniform oil concentration to be applied but, at the same time, to be sufficiently easily broken to produce an oil deposit of maximum insecticidal power.

For dormant washes against insects or eggs known to be susceptible to a "stifling" action, the oil should have a high saturated hydrocarbon and low phenol content. A high aromatic hydrocarbon content favours chemical toxic, rather than physical stifling, action. Vegetable oils are not frequently used as insecticides because of the ready availability of the cheaper and more effective petroleum and tar oils. They have, however, limited uses as ovicides, rapeseed oil being the best of those yet examined. The fatty acids from these oils are insecticidal, the most toxic being those containing 10-12 carbon atoms. They are rarely used, however, partly on account of their high cost and partly because of their phytocidal action.

The soaps also have insecticidal properties, in general of the same order of magnitude as the component fatty acid. They have been studied in detail in an endeavour to determine the relationship between chemical constitution and toxicity, but have found little use in practice.

The use of coal-tar oils is a recent innovation, being first employed in 1920. They make excellent dormant sprays and their use for this purpose spread rapidly, particularly in Europe. The most important for insecticidal purposes are the creosote oils of boiling range between about 180° and the pitching point 360-400°C, and the anthracene or green oils of boiling range between about 270° and the pitching point. The predominant hydrocarbons in these oils are aromatic.

**Sulphur and Copper Compounds.**—Sulphur and a number of its inorganic compounds function as insecticides, acaricides, and fungicides, and although used first as insecticides, now find greatest use for the other purposes. About 230,000 tons of sulphur were used for these purposes in 1938, of which about one-fifth was used in France and over a quarter in Italy, whereas the U.S.A. consumed about 20,000 tons for dusting purposes and 10,000 tons in the manufacture of lime-sulphur preparations.

By far the greatest part of the sulphur used for insecticidal and acaricidal purposes is in its natural state, either alone or mixed with other materials. For dust application, flowers of sulphur, produced by sublimation, or the finely granular material, is employed. The tendency to aggregate is frequently overcome by the addition of a small amount of inert material such as kaolin, carbon black, lead arsenate, or zinc oxide. For spray application, a wetting agent is added to the finely divided sulphur, soap frequently being used for the purpose, although alkaline supplements such as lime and sodium caseinate result in greater efficiency under certain conditions.

One of the most important groups of sulphur compounds used for insecticidal and fungicidal purposes includes the alkali polysulphides, usually marketed in the form of lime-sulphur, Liver of Sulphur, and ammonium polysulphide.

Lime-sulphur is the product obtained by foiling milk of lime (an aqueous suspension of

calcium hydroxide) with sulphur. A preparation having a specific gravity of not less than 1.283 is taken as standard. Much has been written about the chemistry of lime-sulphur, but the consensus of opinion now favours the formation of a mixture of calcium polysulphide and thiosulphate according to the reactions:

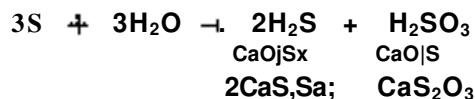

When diluted with water and exposed to air, the polysulphides are first hydrolysed to a slight extent, liberating hydrogen sulphide and giving the lime-sulphur an alkaline reaction. Later, oxidation results in the formation of calcium thiosulphate and *Lee* sulphur, whilst the carbon dioxide of the air reacts to form calcium carbonate, hydrogen sulphide, and free sulphur.

The net result is that, after spraying on foliage, the greater part of the polysulphide sulphur is precipitated as free sulphur, the monosulphide sulphur is lost as hydrogen sulphide and the thiosulphate, being water soluble, is lost. The calcium carbonate, together with any calcium sulphate which may be present, will remain with the sulphur upon the plant surface.

The insecticidal and fungicidal activities of lime-sulphur appear to depend solely upon its polysulphide content. Ferrous sulphate is sometimes used as a spreader, but soaps and calcium caseinate are useless. The use of sulphur sprays followed by hydrocarbon oil leads to severe plant injury, but as a dormant spray, the combination is safe under certain conditions.

**Liver of Sulphur** (obtained by the fusion of an alkali carbonate and sulphur), ammonium polysulphide, and calcium monosulphide have found limited use as a substitute for lime-sulphur, where the disfiguring deposits are to be avoided.

The copper-containing sprays and dusts for plant protection are even more confined to fungicidal problems than the sulphur compounds and will not be detailed here. Chief amongst these is the so-called Bordeaux mixture, consisting of a mixture of copper sulphate and Quicklime in water. A detailed description of this and other copper fungicides is given in H. Martin, "The Scientific Principles of Plant Protection," Arnold & Co., London, 1944.

**Synthetic Organic Contact Insecticides.**—Prior to the pioneering investigations of Tattersfield and his colleagues from 1925 onwards on the relationship between chemical constitution and insecticidal activity, the discovery of new insecticides was usually empirical. It is to synthetic, rather than to plant, products, however, that attention is now being given in the search for better contact insecticides, the Far Eastern needs of the Second World War giving a great impetus to investigations in this direction.

**Dinitrophenols.**—Tattersfield *et al.* (Ann. Appl. Biol. 1925, 12, 218; J. Agric. Sci. 1927, 17, 162, 181) found little difference in the toxic values of phenol and the three cresols towards the eggs of the Purple Thorn moth, but observed a marked increase in toxicity with the addition of nitro groups, the best results being obtained with 3:5-dinitro-o-cresol (DNG). Field tests showed

that although it had phytocidal action and a low solubility in hydrocarbon oils, it was an efficient ovicide in dormant sprays. In an endeavour to overcome the handicap of low solubility, Kagy and Richardson (J. Econ. Entomol. 1936, 29, 52) surveyed related pftienols and found that 2:4-dinitro-6-c-cZohexylphenol possessed the necessary toxicity and solubility.

**Organic Sulphur Compounds.**—Murphy and Peet (*ibid.* 1932, 25, 123) first suggested the use of organic thiocyanates, having found them highly toxic to aphids. Compounded products of this type have been patented (U.S.P. 18088&3) and marketed under the name "Lethana" the principal active constituents being j9-butoxy-jS'-thiocyanodiethyl ether and /?-thiocyanoethyl laurate. Kauryl and butyl "carbitol" thiocyanate and fenchyl or bornyl thiocyanates (V Thanite") are also active ingredients of proprietary winter washes. Few other synthetic organic sulphur compounds have found commercial application although the use of metal xanthates and thiuram sulphides has been patented.

**Amines and Belated Compounds.**—The early work of Tattersfield and Gimingham (1927) led Kearns and Flint (J. Econ. Entomol. 1937, 30, 158) to the discovery of N-amyl-N-benzylcycZohexylamine, which is just as toxic to aphids and red spiders but less phytocidal than the N-amyl-N-benzoyl derivative.

D.D.T., 2:2 - (pp' - dichlorodiphenyl) - 1:1:1-trichloroethane, (C<sub>14</sub>H<sub>9</sub>Cl<sub>5</sub>)<sub>2</sub>CHCl<sub>3</sub>.—Although first prepared in 1874 (Zeidler, Ber. 1874, 7, 1181), the insecticidal properties of D.D.T. were not realised until 1936-37 when J. R. Geigy, S.A., of Basle, found that it was toxic to bugs and subsequently used it to check a plague of Colorado beetle. The work of the Swiss investigators, leading to the discovery of the insecticidal properties of D.D.T. (Lauger *etal.*, *Helv. Chim. Acta*, 1944, 27, 71, 892) began with the search for a moth-proofing agent. Its subsequent rapid development as the result of the collaborative investigations of British, Dominion, and American scientists is one of the epics of the Second World War. An idea of the magnitude and extent of these war-time investigations and uses can be gathered from the fact that the combined potential annual British and American output rose from zero to approaching 20,000 tons in under two years, and that at one time it was estimated that over 300 scientists were engaged in the development of America's war-time D.D.T. uses. Much of the war-time work has yet to be published, but a useful summary of the position in 1946 is to be found in "Some Properties and Applications of D.D.T.," London, H.M. Stationery Office, whilst a comprehensive survey of published work is made in T. F. West and G. A. Campbell, "D.D.T. the Synthetic Insecticide," Chapman and Hall.

D.D.T. is made commercially by variants of the process used by Zeidler, i.e., by the interaction of chlorobenzene and chloral or chloral hydrate in the presence of sulphuric acid. Technical D.D.T. is usually a waxy solid containing between 65 and 80% of pure D.D.T.; the specification for service use in Britain required a setting point of 89°, equivalent to a

pure D.D.T. content of not less than 70%. When pure, it is a stable white crystalline solid, m.p. 108-5-109°, unaffected by exposure to either sunlight, air or water. It is inappreciably volatile at normal temperatures and its solubility in water is less than 0.2 parts per million. It is least soluble in hydroxylic and polar solvents and most soluble in aromatic and chlorinated hydrocarbons:

TABLE I.

Solvent.	Solubility, g. D.D.T. per 100 ml. solvent, at 27-30*0.
cycloHexanone.	100-120
Dioxan	91-100
Methylene chloride.	84-91
Benzene.	77-83
Tricloroethylene.	72-83
"Koppers Solvent No. 327" *	63-71
Anisole.	63-71
Acetophenone.	63-71
0-Dichlorobenzene	63-71
Tetrahydronaphthalene	63-71
Ethyl benzoate.	56-62
"Velsicol AR-60" 2	56-62
Xylene.	56-62
Acetone.	50-55
Methyl isobutyl ketone	46-50
Carbon tetrachloride.	46-48
Tetrachloroethylene.	42-45
Benzyl benzoate.	39-41
Amyl acetate.	39-41
2-Nitropropane.	34-40
Diethylene glycol monobutyl acetate (Butyl carbitol acetate)	34-35
Dimethyl phthalate.	31-33
Dibutyl phthalate.	31-33
"Arochlor 1248" 3	29-33
Nitroethane.	29-33
Indalone.	29-33
Ether.	27-28
Medium kerosene extract <sup>4</sup> .	28
Tetrahydrofurfuryl alcohol	18-20
Ethylene glycol monoethyl ether	17-18
Ethylene glycol monoethyl ether phthalate.	10-16
Diacetone alcohol.	ca. 15
Pine oil (Hercules "Yarmor" 302)	ca. 15
Butyl stearate.	ca. 13
Diethylene glycol monoethyl ether	ca. 12
Sesame oil.	ca. 10
Fuel oil No. 2.	ca. 10
Benzyl alcohol.	ca. 10
Ethylene glycol monophenyl ether	ca. 10
Coconut oil.	ca. 9
Cottonseed oil.	ca. 9
Stoddard Solvent White 5.	ca. 9
Kerosene crude.	ca. 8
Fuel oil No. 1 *	ca. 8
Oleic acid.	*ca. 8
Castor oil.	ca. 7
Ethyl alcohol (absolute)	ca. 6-7
Dipropylene glycol.	ca. 5
Light petroleum (100-120°C)	ca. 5
Kerosene, refined ("Deobase")	ca. 4
isoPropyl alcohol.	ta. 2-5
2-Ethylhexanediol 1:3 ("Rutger's 612")	ca. 2-5
Ethyl alcohol 95%.	ca. 1-5
Triethanolamine.	ca. 1-5
Propylene glycol	ca. 1-5
Difluoro dichloromethane ("Freon") (under pressure at 30°C.)	ca. 2-0*
Methyl chloride (under pressure at 30°C.)	60-70*

\* O. per 100 g. of solvent.

1 Coal-tar hydrocarbons boiling range 230-270°C.

2 Polyalkylated naphthalenes.

3 Chlorinated diphenyl.

4 *Ex. Ass. in Oil Co.*

5 Refineoipetroleum hydrocarbon used in dry-dean-  
ing industry.

TABLE II.

Solvent.	Solubility, g. D.D.T. per 100 ml. solvent, at 25-29°c.
1:2-Propylene oxide	170
Tetrahydrofuran	105
cyd6H.exa.none	100
Dimethylformamide	100
Methyl ethyl ketone	100
fcoPhorone	100
Mesityl oxide	100
Dioxan	90
Pyridine	90
Methyl acetate	87
1-Methylnaphthalene	65
Quinohne	60

TABLE III.

Solvent.	Solubility, g. D.D.T. per 100 ml. solvent, at 20°C.
" Nineties " toluene	42
Toluene	41
Benzene	40
Motor benzole	35-5
Wood turpentine	11

TABLE IV.—WEIGHT BSR CENT. SOLUBILITIES.

Solvent.	Temperature °C.				
	0	7-2	240	450	480
Acetone	21-2	27-3	40-3	—	590
Benzene	6-8	27-1	440	—	67-8
Carbon tetra- chloride	90	10-5	180	34-8	—
Chloroform	18*2	219	310	47*4	—
Dioxan	80	290	460	—	610
Ether	150	18-9	27-5	—	—
Alcohol (95%)	0-8	10	2-2	—	—
Light petroleum (30-60°0.).	1-7	2-4	4-8	—	—
Pyridine	210	360	510	—	620

D.D.T. is highly toxic to most arthropods but much less so to mammals. It is toxic both by ingestion and contact, but is relatively slow-acting and does not possess the required "knock-down" effect of pyrethrum. It is neither repellent nor ovicidal, but in some cases, e.g., mosquitoes, it attacks the larval stage. Its outstanding virtue is its pronounced "residual effect" unequalled by other insecticides. Deposited on surfaces, whether as a dust, or as an oil solution or as an emulsion, it retains for several weeks its lethal effect on insects coming into contact with it.

So far, most effort in the application of D.D.T. has been devoted to the control of the disease vectors, mosquito, fly, and louse. Its use with domestic stock and agricultural pests has been less completely studied; the data already obtained in this field, however, are

adequately summarised in H.M. Stationery Office's publication, "Some Properties and Applications of D.D.T."<sup>1</sup> For direct attack against adult flying mosquitoes, aerosols and fine mists are employed. Spraying for residual effect is, however, more general. Spray from the air for this purpose is usually applied at the rate of 0-2 lb. D.D.T. per acre (2 quarts of 5% solution, usually kerosene, per acre, or its equivalent). Ground spray, however, is now considered more effective, and usually consists of spraying the walls and ceilings of houses, barns, etc., at dosages of 50 mg. D.D.T. per sq. ft.

The period of control effected by residual spraying from the air varies according to climatic conditions and terrain, but 1-2 weeks' effective control only is normally obtained. The efficiency of residual spraying of house interiors again depends upon such factors as dosage, the type of surface sprayed, and temperature, but at least 8 weeks of effective control is obtained and in temperate climates much more. Aeroplane spraying at the rate of 0-1-0-2 lb. D.D.T. per acre has also been successfully applied to the treatment of large areas of water. The duration of control is variable, depending to a certain extent upon the amount and type of vegetation present and also upon the wind; it is rarely longer than 4-7 days. Larval control by this means is usually effected by means of oil or petroleum distillate solutions, sometimes with oleic acid as a spreader; emulsions are not recommended in the main, as there is a greater risk of killing fish when they are used.

Whilst a combination of all or some of these methods may be necessary in mosquito control, all the evidence points to the regular residual spraying of dwellings and other buildings as being the most effective single method of control. This method has also proved effective against house and stable flies, bedbugs, and ants; for rapid knockdown of the former a small amount of pyrethrum is usually added.

The role played by D.D.T. in the control of the typhus epidemic in Naples in early 1944 is now well known, and considerable experience has since been gained in the control of the disease vector\* the body louse (*Pediculus humanus*) with D.D.T. 1J oz. of 10% D.D.T. dust applied to clothing remains effective for 2-3 weeks provided the clothing is not washed. Better results are obtained by the use of clothing impregnated with D.D.T. to the extent of 1%. 5-10% D.D.T. dust (with pyrophyllite, talc, kaolin as extenders) is preferable to solutions for use against cockroaches.

Much remains to be done before its true value as a horticultural and agricultural insecticide can be assessed. Until then, caution must be observed in its use in this field. D.D.T. is characterised by its toxicity to most arthropods and, as a result, beneficial insects such as bees, the predatory *Macrocerdrus*, and the codling moth parasite are apt to be destroyed by its unintelligent application. Furthermore, where the codling moth and red spider are found together, extinction of the former has resulted in a vast increase in the red spider population which is resistant to D.D.T.

Care must also be observed in using D.D.T.

solutions of high concentrations. Although D.D.T. is toxic to man, it has been proved by British and American investigators (c/. Cameron and Burgess, Brit. Med. J., 1945, 865) that there is a wide margin of safety in its use as an insecticide. Used as a dust there is practically no danger of absorption through the skin; D.D.T.-containing aerosols may be inhaled with safety, and reasonable use of D.D.T.-containing solutions is free from risk. This also applied to the use of oily concentrates provided precautions are taken to prevent contact with the skin for long periods. Cameron and Buigess (I.e.) showed the median lethal dose (L.D.<sub>50</sub>) for guinea pigs, rabbits, and rats to be:

	Rabbits,	Guinea Pigs,	Bats.
Skin application (mg. per kg.)	300	1,000	3,000
Gastric administration (mg. per kg.)	300	400	800
Subcutaneous injection (mg. per kg.)	250	900	1,500

The L.D.<sub>50</sub> dosage for cats (single dose) is about 250-300 mg. per kg. and not more than 300 mg. per kg. for chickens. It is also claimed that fish are unaffected by concentrations of not more than 1 part D.D.T. to 20x 10<sup>11</sup> watery

"Gammexane" (γ-hexachlorocyclohexane), C<sub>6</sub>H<sub>6</sub>Cl<sub>6</sub>.—Originally marketed as "666," γ-hexachlorocyclohexane, like D.D.T., has marked residual effect and is used both as a contact and a stomach poison. The insecticidal properties of this compound were discovered by Messrs. Imperial Chemical Industries in 1942, (Slade, Chem. and Ind. 1945, 40, 314) although it was originally prepared by Michael Faraday in 1825. The crude product of commerce, made by the chlorination of benzene, is a sandy coloured powder and is a mixture of at least four isomers; of the four isomers, the γ has by far the greatest insecticidal activity (β negligible; α 10 times as effective as β; and δ 3,600 times as effective as α), and whilst the lethal dose varies, from one pest to another, it is generally lower than that for other insecticides.

It is usually marketed as the undiluted crude reaction product or admixed with an inert carrier such as gypsum or powdered limestone. It can also be obtained in concentrated solution or emulsion form or as a smoke powder. The pure γ-isomer is a colourless, bitter crystalline substance, m.p. 112-5° with low vapour pressure (0.03 mm./20°; 0.14 mm./40°; 0.48 mm./60°), stable at high temperatures, practically insoluble in water but soluble in the common solvents given in the Table opposite.

Gammexane has not yet been tested as extensively as D.D.T. but sufficient has been done to show that it has exceptional insecticidal activity, comparable with D.D.T. in most respects and in some cases better, being more effective against the flea beetle (*Phyllotreta* spp.) than derris, and much better than D.D.T. against locusts. It has been used successfully against the common disease-carrying insects, household, stock, horticultural, stored food, and agricultural

SOLUBILITIES OF ISOMERS OF HBXAOHLOHO-CYCLOHEXANE AT 20° C.

Solvents.	Solubility, gk per 100 g. solvent			
	Alpha.	Beta.	Gamma.	Delta.
Acetic acid, glacial	4.2	1.0	12.8	25.6
Acetone	13.9	10.3	43.5	71.1
Benzene	9.9	1.9	28.9	49.4
n-Butyl alcohol	1.6	0.7	4.4	19.4
n-Butyl acetate	10.8	7.1	31.6	54.4
iso-Butyl alcohol	0.9	0.4	3.0	13.5
Carbon tetrachloride	1.8	0.3	6.7	3.6
Chloroform	6.3	0.3	2.40	13.7
cycloHexane	1.4	0.8	4.6	2.7
cycloHexene	5.5	1.0	17.4	14.6
cycloHexanol	1.9	0.6	4.6	17.3
cycloHexanone	17.3	1.21	36.7	49.9
"Dec" (decahydro-naphthalene)	2.5	0.4	8.7	10.4
Diacetone alcohol	5.4	2.9	21.0	30.5
Diethyl carbonate	10.2	4.1	28.4	46.3
Diesoil	1.5	0.3	4.1	9.2
Dimethyl acetal	14.3	3.4	38.7	54.8
Dioxan	33.6	7.8	31.4	58.9
Ether	6.2	1.8	20.8	35.4
Ethyl alcohol	1.8	1.1	6.4	24.2
Ethyl acetate	12.7	6.9	35.7	58.5
Ethylene dichloride	7.9	0.6	28.9	27.3
Ethylene glycol	0.3	0.1	0.6	4.1
Ethylidene chloride	6.7	0.7	20.2	19.5
Glycerol	0.02	Nil	0.06	0.2
Methyl alcohol	2.3	1.6	7.4	27.3
Methyl acetate	13.6	6.7	27.7	62.1
Methyl propionate	13.0	7.9	37.8	61.6
Monochlorobenzene	7.4	0.4	23.4	21.4
Naphtha, heavy (230-270°)	5.8	1.5	18.1	30.4
Odourless distillate (198-257°)	0.8	0.02	2.0	1.1
Paraffin (138-212°)	1.2	0.05	3.2	4.6
Perchloroethylene	2.4	0.1	7.4	3.5
Pentane	C9	0.1	2.2	1.6
Light petroleum (40-60°)	0.7	0.1	2.1	1.6
Light petroleum (60-80°)	1.0	0.2	2.7	1.8
Light petroleum (80-100°)	1.0	0.2	2.9	3.2
Light petroleum (100-120°)	1.3	0.2	3.5	3.5
n-Propyl alcohol	1.6	1.1	5.2	21.1
iso-Propyl alcohol	0.6	0.4	2.8	1.80
Toluene	9.0	2.1	27.6	41.6
Trichloroethylene	3.7	0.3	14.7	7.6
Distilled water (parts per million)	---	(5)	(10)	(15)
White oil	< 5	0.02	1.9	4.4
Xylene	8.5	3.3	24.7	42.1

pests, but it is finding its greatest use in the last field.

Its toxicity to man has not yet been determined, but it has low toxicity when applied to the skin or administered orally in single doses, being fairly comparable with D.D.T. in this respect.

*Other New Organic Insecticides having Residual Properties.*—The discovery of the residual insecticidal properties and wide applicability of D.D.T. and Gammexane has inspired chemists and entomologists all over the world to search for new synthetic insecticides in the hope that one may be discovered which is easier to manufacture and disseminate, completely non-toxic to man and having a pronounced knockdown effect in addition. No compound having all these desirable properties has yet been produced, but several for which high claims have been made are already on the market. The most interesting

of these are "Velsicol 1068," a compound of unstated structure but having the formula  $C_{10}H_6Cl_8$ , and the German war-time discoveries,  $\alpha$ -chloromethyl-4-chlorophenylsulfone ("Lau8eto New") and the hexaethyl ester of tetraphosphoric acid ("Bladen").

#### Fumigants.

Fumigants are chemical substances which exert their insecticidal action in the gaseous state, and consequently are commonly used for disinfecting large closed spaces such as dwellings, ships, and greenhouses.

**Hydrocyanic Acid (Hydrogen Cyanide, Prussic Acid, HCN).**—The acid, when pure, is a colourless gas at temperature above  $26^\circ C$ , its boiling-point, with an odour of bitter almonds. It was first employed against the scale-insect pests of citrus in California in 1886, but its use is now routine in general glass-house cultivation and against citrus scale-insects which are highly resistant to other insecticides.

It is usually prepared *in situ* by the action of sulphuric acid on sodium cyanide (cyanide, 1 oz.; concentrated sulphuric acid, 1½ fl. oz.; water 2-3 fl. oz.), by gasifying the anhydrous liquid acid contained in cylinders or by the action of moisture on calcium cyanide ("Cyanogas" process).

Because of its highly toxic nature, "warning" gases, such as the lachrymators chloropicrin and cyanogen chloride, are frequently mixed with the cyanide.

Although the mode of action of hydrocyanic acid has been the subject of much discussion, it would appear to be an interference with normal enzymatic activity by combining with the catalysts present in living tissue. Hydrocyanic acid gas is, under certain conditions, toxic to plant growth and for this reason fumigation at night, when the temperature is lower, and the withholding of watering for 24 hours before treatment, are recommended.

**Carbon Disulphide.**—Carbon disulphide,  $CS_2$ , is a colourless liquid, b.p.  $46.3^\circ C$ , readily volatilised at ordinary temperatures. The vapour, which has an unpleasant odour, is highly inflammable and is explosive when mixed with air over a wide range of concentrations; hence it must be used with great caution. It is highly toxic to all forms of life and is used largely as a soil insecticide and as an insecticidal fumigant in dwellings and warehouses.

**Halogenated Hydrocarbons.**—This class of fumigant, whilst less toxic in general than carbon disulphide has the great advantage of being non-inflammable. Chief amongst these are carbon tetrachloride,  $CCl_4$ ; ethylene dichloride,  $C_2H_4Cl_2$ ; and tetrachloroethane,  $C_2H_2Cl_4$ . The latter is the active agent in certain proprietary fumigants for use against the white fly. Like other chloro-hydrocarbons, it must be used with caution because of its phytocidal action. *p*-Dichlorobenzene,  $C_6H_4Cl_2$ , and 2:2'-dichloro-diethyl ether,  $O(C_2H_4Cl)_2$ , are finding increasing use as soil insecticides; the former is well established as a protectant against house moths. Methyl bromide,  $CH_3Br$ , is finding increasing use in the treatment of stored food products.

**Ethylene Oxide,  $(CH_2)_2O$ .**—This compound, a gas at ordinary temperatures, b.p.  $10.7^\circ C$ , is inflammable and toxic to seeds, seriously affecting germination. If admixed with 9 parts of carbon dioxide, the toxic and fire risks are eliminated, and such mixtures are widely used as fumigants in warehouses.

**Naphthalene,  $C_{10}H_8$ .**—The largest single constituent of coal tar, naphthalene is, when pure, a highly crystalline solid, m.p.  $80^\circ C$ , b.p.  $218^\circ C$ , having relatively high volatility. In 1936 nearly 7,000 tons were used in the U.S.A. in the form of "moth balls," but it is finding increasing use as a greenhouse fumigant against thrips and the red spider. The naphthalene may be volatilised by heating, or preferably by circulating the greenhouse air through a solution of naphthalene of known concentration in a suitable solvent.

#### Repellent\*.

Cedar wood oil, citronella oil, oil of cloves, etc., have long been used as insect repellents, even if of doubtful efficacy, but it was not until the Far East Service needs in the Second World War stimulated research that really effective mosquito repellents were discovered. Three of the most effective and widely used of the thousands of possible repellents tested are *aa*-dimethyl-*a*-carbobutoxydihydro-*y*-pyrone ("Indalone"); 2-ethyl-1-hexanediol ("Bulger's 612") and dimethyl phthalate (DMP), and were used admixed in the ratio 1:1:3 by the American Services. Liquid DMP was favoured by the British Service authorities, although a considerable amount of investigatory work has been carried out by Christophers and others (1943-45) in an endeavour to develop alternatives. Liquid repellents of this type are usually applied as such to the skin, and remain effective for 2-4 hours in temperate climates.

Trichloroacetylchloroethylamide has been shown by the Germans to have marked repellency towards non-anopheline mosquitoes.

DMP in emulsion form has been shown to be effective against midges.

#### Acaricide».

The search for acaricides or "miticides" was also intensified during the 1939-45 war because of the need to control the scrub typhus-carrying mite *Trombicula*. Dibutyl phthalate (DBP) was recommended throughout the war as the most satisfactory and lasting repellent, applied usually to socks, trouser bottoms, etc., but not to the skin. Benzyl benzoate, well known for its efficacy against scabies, was subsequently found to be much more effective.

#### Dispersal Methods.

Insecticides are usually disseminated either as the undiluted powder or liquid, in solution, emulsion or suspension form, or as an aerosol. The most marked advances in formulation were made during the war and the investigations on D.D.T., and the following examples of methods developed for its compounding and dispersal are typical of those used in the case of the majority of insecticides.



*Solutions.*—Early D.D.T. formulations almost exclusively made use of kerosene as solvent because of its ready availability and proved usefulness with other insecticides. Along with many other petroleum distillates, it has the disadvantages of being somewhat irritant to the operator and phytocidal; in addition it is a relatively poor solvent, a saturated solution containing only about 5% D.D.T. Nevertheless, D.D.T. in kerosene has been most widely used to control disease vectors by air and ground spraying. The use of auxiliary solvents, such as cyclohexanone, aromatic hydrocarbons, polyalkyl naphthalenes, to increase solubility and to prevent D.D.T. crystallising out, has been given extended trial.

*Emulsions.*—Oils and other insecticides not soluble in water are frequently applied, particularly as agricultural sprays, in emulsion form. Whilst they tend to corrode spraying equipment and frequently to break, the saving in expensive solvent and transport is a great advantage. Insecticidal emulsions of spray strength are usually prepared by the "tank mix" method or by means of stock emulsions or "miscible" oils. In the former method, the insecticide is emulsified in the spray tank by vigorously agitating with water and an emulsifier unaffected by hard water such as Bordeaux precipitate, sulphite lye or blood albumen. A variant is the two-solution method, in which a suitable liquid fatty acid, e.g., oleic acid, is dissolved in the oil to be emulsified and this solution is added to dilute solutions of alkali, the emulsifier thus being formed *in situ*. Stock emulsions are emulsion concentrates obtained by processing oil-water-emulsifier mixtures in a colloid mill. The miscible oils contain the emulsifier dissolved in the oil, the term, usually taken to cover all products which are clear, one phase, solutions yielding emulsions when diluted with water to spray strength. Stock emulsions containing concentrated D.D.T. solutions have met with some success, although they have not by any means replaced solutions. A typical and well-tested concentrate is made up as follows: D.D.T., 25; "Triton 2C-100," \*; xylene, 68 parts by weight.

*suspensions.*—The dissemination of agricultural insecticides, in particular, in suspension form, results in great economy, in that no solvents are required and transport problems are minimised. The arsenicals are widely dispersed in this manner, and the modern synthetic insecticides have been satisfactorily wet-ground with water and a wetting agent, to give pastes readily dilutable by water to give spray strength solutions. To ensure even coverage, it is usually advisable to agitate during spraying.

*spraying Apparatus.*—For the aerial spraying of solutions, emulsions, and suspensions, use is normally made of aircraft travelling at 150-200 m.p.h. at the lowest height consistent with safety, employing spray tanks similar to those used for laying smoke screens. No attempt is made to produce droplets of uniform size; the liquid is usually ejected by gravity through an open orifice.

Attempts have been made to disperse D.D.T. and other insecticides from the air by feeding a concentrated solution into the exhaust of the

airplane; helicopters and slow moving craft with perforated spray tubes have also been tried. The results so far obtained suggest that none of these methods is greatly superior to that originally used.

For ground spraying, two types of spray are normally required, a very fine, persistent mist to attack insects on the wing and to penetrate into resting places, and a rather coarse spray for treatment of walls, ceilings, foliage, etc., for residual effect. Most sprayers on the market leave a lot to be desired, few are robust enough, almost all give too coarse a spray at too high an output, whilst most nozzle designs are so crude as to vary from model to model and are incapable of proper adjustment. Of available hand sprayers, the "MISH" developed by the Malaria Institute in India has proved mechanically most efficient. Stirrup pumps, suitably adjusted to handle organic solvents, can be used as a means of dissemination, whilst the conventional knapsack sprayers are quite satisfactory within certain limits.

Power-operated sprayers have been used for a variety of purposes, particularly in agriculture, for a number of years. They mostly embody a swivel plate nozzle through which liquid is forced under relatively high pressure, and are more robust and, in the main, better designed than the hand sprayers.

*Powders.*—D.D.T., Gammexane, and other insecticides such as Paris Green, cuprous cyanide, and derris, have been extensively applied in dust form by incorporation in finely divided inert powders such as kaolin, talc, and pyrophyllite. The principal use of D.D.T. in this form has been as a 5 or 10% dusting powder for body-louse control. Derris-containing dusts are almost entirely used for horticultural purposes. Powders are usually disseminated from the air or by means of hand-activated (Just guns).

*Aerosols.*—Considerable effort has recently been devoted to the development of technique whereby D.D.T. and Gammexane may be disseminated by fine atomisation of solutions or by thermal generation.

One method is by means of the aerosol "bomb" in which a concentrated solution of the insecticide is dispersed in the form of a very fine mist by means of a compressed gas or the evaporation of a low boiling solvent such as "Freon" or methylene chloride. Various models have been developed in the U.S.A. which usually contain about 1 lb. of insecticide and propellant, and are capable of spraying continuously for 15 minutes. A typical charge is: pyrethrum extract (20% pyrethrins), 1 part by volume; D.D.T., 0.5 parts by weight; sesame oil, 50 parts by volume; kerosene, 5.0 parts by volume; cyclohexanone, 5.0 parts by volume; and Freon, *q.s.* Such a charge is equivalent to 1 gallon of standard 5% spray and 4 seconds spraying will disinfest 1,000 cu. ft.

In Britain, an individual sprayer, capable of disinfesting 1,000 cu. ft. and discharging for 4-5 seconds has been developed. It consists of a "Sparklet" bulb with a dip leg and "break off" tip. It works on the same principle as the soda-water syphon and uses carbon dioxide as propellant.

Considerable work is in progress on the possibility of dispersing "residual effect" insecticides by thermal generation. Modified thermal smoke and tear-gas generators have been tested with varying results, the main disadvantage being that all such methods are susceptible to meteorological conditions.

#### RODENTS.

Bats and mice are controlled by a number of methods, chief amongst which are traps, poisoned baits, fumigants, and repellents. Details of the conventional methods are to be found in A. Mallis, "Handbook of Pest Control" Macnair-Dorland Co., 1945.

*Traps.*—Trapping is applicable where the use of poisons is dangerous or where the odour of decaying carcasses may become objectionable. Any form of trap may be used, the spring and cage types being normally employed. It is common practice to use various types of bait, preferably of a type not readily available in the location to be cleared.

*Poison Baits.*—Greatest use is made of poison baits, because of their effectiveness and the ease with which they are prepared and distributed. The poisons used are usually the quick-killing strychnine or strychnine sulphate, phosphorus paste, and zinc phosphide, or the slower acting red squill, barium carbonate, arsenious oxide, and thallium sulphate. The use of the former is often restricted because of their toxicity to human beings and animals, particularly as the latter have the advantage of allowing the rat time to leave the building before dying.

Of the rodenticides, perhaps the best is red squill, in that it is toxic to rats and mice and practically harmless to man and other animals. It is a perennial bulbous plant, belonging to the lily family (*Urginia maritima* L.) and grows wild in the hilly country bordering the Mediterranean. The bulbs average 3-6 in. across and weigh up to 6 lb., and are sold either oven-dried and powdered or as an extract in liquid or paste form.

The toxicity of squill is extremely variable depending upon the method of preparation and preservation, freshness, etc.; the lethal dose of good grade unfermented, oven-dried, sliced squill bulbs is about 25 mg. per kg. for white rats.

In recent years, in the U.S.A. in particular, an active search has been made for new synthetic organic chemical rodenticides having constant toxic effect upon the rodent and at the same time being harmless to man, and domestic and farm animals. The ideal rodenticide has not yet been found but two types of compound show considerable promise, i.e., thiourea derivatives and certain organic fluoro compounds. Of the former, o-naphthylthiourea ("ANTU" or "109") has shown most promise, but whilst it is effective against the Norway rat it is relatively innocuous against the black rat, prairie dogs, and Californian field rodents.

Sodium fluoroacetate is considered the most promising of the organic fluoro-compounds although its use has not yet been confirmed, its M.L.D. against rats being 5 mg. per kg.; it does

not show selectivity towards particular species and it is also good for field pest control. It is acceptable to rodents, toxic to dogs and cats, but relatively harmless to man and larger animals.

During the Second World War the Germans developed "Castrix" (made from acetoacetic ester and urea followed by chlorination and amination) and p-dimethylaminobenzenediazo sodium sulphionate as substitutes for thallium in rodenticides.

In using red squill and other rodenticides in poison baits, a wide range of attractive food baits may be employed, such as bread crumbs, fish, meat, starch, corn syrup, and bacon fat. It is customary to use non-poisoned baits first to overcome the rat's inherent suspicion and then use a variety of poison baits for limited periods only.

Viruses have been used effectively, such as the mouse typhus-fever virus, but their widespread utilisation is not normally recommended.

*Fumigants.*—The use of fumigants is limited as a means of rodent control. Carbon disulphide and smoke cartridges containing phosphorus have found limited use in the suppression of Californian field-rodent pests. Cyanogas is used extensively for disinfecting buildings, ships holds, and rabbit runs.

*Repellents.*—No repellent has yet been devised capable of preventing damage to vegetation or stored materials by animals. As far as rats are concerned, some slight success has been obtained with copper naphthenate and with sulphur, whilst the painting of young trees and shrubs with a mixture of copper compounds and lime-sulphur in a urea-formaldehyde binder has been shown to act as a protectant against the depredations of rabbits.

Attempts have also been made to limit the activities of rodents in the field by electrified or barrier fences and by sight and hearing control devices. These latter methods use reflectors, lights, cloth streamers and the like, dyeing of stored food-products a bright colour, and the use of flash guns, firearms, and sundry noise-makers. None has so far achieved sufficient success to warrant its large-scale utilisation.

F. N. W.

**P ETA LITE.** A lithium aluminium silicate,  $\text{LiAlSi}_4\text{O}_{10}$ , or  $\text{Li}_3\text{O} \cdot \text{Al}_2\text{O}_3 \cdot 8\text{SiO}_2$ , crystallising in the monoclinic system, but usually massive, foliated cleavable. It has a perfect basal cleavage, is brittle, has a hardness of 6-6½, and  $\rho$  about 2.4. Colourless, white, grey, and occasionally with a greenish or reddish tinge; lustre vitreous, but pearly on cleavage planes; transparent to translucent. In common with the more important lithium minerals, spodumene, lepidolite, and amblygonite, it is typically found in certain granitic pegmatites. Petalite is a minor source of lithium.

D. W.

**PETHIDINE HYDROCHLORIDE.** Ethyl 1-methyl-4-phenylpiperidine-4-carboxylate hydrochloride. Analgesic with morphine-like action. B.P.C. Supp. VII (v. SYNTHETIC DRUGS).

S. E.

## PETROLEUM.

## INTRODUCTION.

Petroleum or "rock oil" in its more limited sense includes hydrocarbon liquids which are obtained from seepages or wells drilled to varying depths, from which the oils either flow because of underground gas or hydrostatic pressure, or are pumped in the absence of such pressure. However, the term may be used generically to include, in addition to liquid oils, other closely related natural hydrocarbon substances such as natural gas, asphalts, and waxes. The predominating compounds in petroleums are hydrocarbons, which include representatives of many groups. In addition, organic compounds of sulphur, nitrogen, and oxygen are present in minor amounts, as well as inorganic substances which form ash when the oils are burned. Petroleums vary from almost colourless, limpid liquids to black viscous semi-solid materials. Between these limits practically all intermediate gradations occur. The specific gravity may vary from 0.70 to over 1.0, the volatility from that of natural gasoline to zero, and the consistency from that of water to a solid black tar. Some petroleums from the Kettleman Hills field in California are gasolines which have been utilised directly as motor fuel, while, in contrast, some Mexican petroleums are essentially asphalt and contain only small amounts of distillable components. Some petroleums contain so much paraffin wax that they are solid at ordinary temperatures.

The colours of crude oils are as varied as the rainbow. By transmitted light they show shades of yellow, amber, green, cherry, reddish-brown, brown, and black, and many exhibit in addition a bluish or greenish fluorescence. Their odours vary from pleasant to nauseating. Some lighter oils have an ethereal odour, some are sweet, and some smell like turpentine or camphor. Some sulphur petroleums emit hydrogen, sulphide and the vapours of mercaptans, so that they are decidedly toxic to plants and animals.

From antiquity there was some knowledge of petroleum from surface deposits and seepages of oil and gas. Ancient mining methods were of a primitive character, and limited to placer, open-cut or pit mining. It seems probable that depths greater than 300 ft. were seldom worked, particularly because of the issuance of inflammable gas associated with the underground extensions of surface deposits. However, the Chinese drilled for oil in 200 B.O. to a depth of 3,500 ft., using bronze bits and bamboo tubes to pipe oil and gas to the surface for heating and lighting.<sup>1,3</sup> This technique was unknown in the Western world until much later.

The earliest recorded use of asphalt was in the Euphrates Valley. In this locality the Sumerians as early as 3000 B.C. used it in statuary, pottery, building, and roads.<sup>2</sup> The sources of the material were seepages and outcrops which are still in existence in many localities in the near East, in the areas surrounding the Persian Gulf, the Red Sea, the Eastern Mediterranean, and the Black and Caspian Seas. These areas still contain outcrops and seepages which currently account for the asphalt in the

regions of Batum, Surakhani, Tiflis, Baku, Grozny, and Maikop. Many of the surface soils are impregnated with readily inflammable hydrocarbons, and there are continuous emissions of natural gas giving rise to perpetual fires which are shrines for cults of fire worshippers. Mummies of the Egyptian kings were so-called because of the use of bituminous material for the preservation of the deceased, the word mummy being based on the Coptic or Egyptian word "mum," meaning bitumen. The Babylonians used asphalt in bricks for building construction, in roads, and for setting stones in floors, that of Nebuchadnezzar's palace being still in fair condition.

Asphalt seepages are located in the Dead Sea Basin, and semi-liquid asphalts rise to the surface of the sea from whence they are skimmed and used by the nearby inhabitants for waterproofing boats and for heating and cooking.

The records of Greek and Roman history show very little evidence of the use of petroleums or asphalts, but rather the use of pitches and tars from the distillation of wood. Evidently the larger natural sources of asphalt and petroleum were in the hands of Asiatics and not available to the Western Empires.

The petroleum industry really began with the bringing in of the Drake well on August 27, 1859, at Titusville, Pennsylvania at a depth of 69 ft. Previous to this time there had been no systematic drilling for oil, although Indians in New York and Pennsylvania had used the oil from seepages for several hundred years for medicinal purposes. The occurrence of oil seepages near the town of Cuba in Western New York was known to the earliest white explorers;<sup>4</sup> and George Washington owned lands in Pennsylvania which contained a so-called "burning spring" of oil.<sup>6</sup> Petroleum encountered in wells drilled for salt was considered a nuisance. However, small amounts recovered in connection with salt wells were bottled and sold as cure-alls. In 1873 a well was drilled which flowed oil in the Baku field in Russia, and in 1875 the Nobel brothers commenced systematic production, refining, and transportation of Russian petroleum on a large scale, which initiated the Russian industry.<sup>6</sup>

Since 1859 the petroleum industry has grown to be one of the world's largest. The world production of petroleum in 1859 was 2,000 barrels.<sup>7</sup> In 1860 a production of 600,000 barrels in the Pennsylvanian fields flooded the market and depressed prices.<sup>7</sup> A reliable estimate of the total world production of petroleum of all types in 1944 was 2,621,734,000 barrels,<sup>8</sup> with an insatiable market. Estimates for 1945 are made difficult by the transition from war to peace, and inadequate reporting of production in many countries. No reliable figure for world production, in 1945 is available. A well was drilled to a depth of over 16,000 ft. in 1944.<sup>9</sup>

## ORIGIN OF PETROLEUM.

Many theories have been advanced to account for the origin of petroleum.<sup>10</sup> These may be broadly subdivided into inorganic and organic, although the latter have practically superseded the former in the minds of present experts. The earliest inorganic theory was proposed by

Mendele'eff, who stated that hydrocarbons similar to those of petroleum could be formed underground by the action of water on carbides as in the following equations:

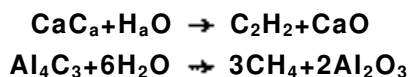

The difficulty in this theory is that it does not indicate how the higher molecular weight hydrocarbons of petroleum could be formed. The interaction of carbon dioxide, water, and sodium has been suggested as a mode of hydrocarbon formation, but this proposal again does not indicate the source of sodium or the mechanism whereby the higher molecular weight hydrocarbons could be produced. Attempts have been made to associate petroleum origin with volcanic activity, but geologists have proved that such association is not characteristic but merely accidental, as in the case of some Mexican fields. It has been suggested that formation of heavy hydrocarbons from lighter ones has been promoted by alpha radiation, but this is difficult to confirm. The inorganic theories fail to account for the presence of chlorophyll porphyrins in some asphalts, the invariable presence of nitrogen compounds in all petroleum, and the optical activity observed in many instances.

The source of petroleum is now believed to be the organic matters deposited in marine waters or land-locked seas in certain geological periods. Such seas have occupied much of the continental shelves in past epochs and have been a favourable environment for the existence of large amounts of marine life, including diatoms, algae, plankton, fishes, and molluscs. These have been deposited in waters and covered by sediments such as clays and marls, so that decomposition of the organic remains has taken place under anaerobic conditions. The initial stage of putrefaction may have been biochemical, or due to moderately elevated temperature and pressure. Successive sediments have covered the organic deposits and mild metamorphism has sealed in the organic remains. The mechanism of the conversion of the primary organic matter into petroleum hydrocarbons remains in doubt, since the best evidence points to the fact that such deposits have probably not been exposed to temperatures over 60°C. (140°F.). « No petroleum source rocks are encountered before the Silurian Period in the early Paleozoic Era, and most have been\* found in the late Paleozoic and the Mesozoic. In determining the source rocks, account is taken of the migration of the original petroleum, which frequently is found in formations in which it could not have originated. Fatty oils may have been a source, as it has been shown that petroleum is produced when animal fats are distilled under pressure.

In contrast to the animal origin of petroleum, coal measures are distinctly from vegetation, and the association of coal and petroleum as in the Appalachian region of the United States is not significant since\* they occur in different non-conformable strata.

The known occurrences of petroleum bear out the hypothesis of origin and accumulation in mobile epicontinental shelf regions, and the fore-

deeps of folded mountain ranges. Thus the main areas of petroleum production correspond to previous land-locked seas occupying intercontinental troughs or depressions in the earth's crust, as follows: "

1. The environs of the Mediterranean, Black, and Caspian Seas and the Persian Gulf, occupying the depressed segment between the continents of Africa, Europe, and Asia. In this region the magnificent petroleum resources of the Near and Middle East are now being developed.
2. The environs of the Gulf of Mexico and the Caribbean Sea, lying in the land-locked basin between the continents of North and South America. This region contains the *Throat* important petroleum resources so far developed in the Western Hemisphere; Trinidad, Venezuela, Colombia, Mexico, and the Gulf Coast area in the United States.
3. The environs of the shallow island-studded seas which lie between the continents of Asia and Australia in the Far East. Important petroleum resources have already been developed on the islands of Borneo, Sumatra, Java, and New Guinea, and much promising territory remains to be explored in this region.
4. The environs of the land-locked Arctic Sea, lying in the north-polar depression between the continents of North America, Europe, and Asia. This region is almost wholly unexplored, but it is characterised throughout by conspicuous surface evidence of petroleum with an oil field already developed on the Arctic Circle.

The other occurrences are on the lower slopes of the world's principal mountain ranges, for example, that east and west of the Rocky Mountain range in North America and the Andes in South America, the Alps in Europe, and the Himalayas in Asia.

In Europe tertiary foredeep-pools occur from the Vienna Basin through Galicia into Bumania, and minor pools have been found in Italy and Albania. Late Paleozoic occurrences are probable in England, eastern Holland, and Westphalia. Other European basins occur in north-western Germany, Hungary, and the Rhine and Rhone Valleys.

In North America tertiary oil pools occur east of the Rocky Mountains from Alberta in Canada, through Montana and Wyoming and west of the mountains in California. Late Paleozoic deposits occur in New York, Pennsylvania, West Virginia, Kentucky, Tennessee, and Alabama. Another Paleozoic province comprises the entire central tableland, including Michigan, Ohio, Illinois, Kansas, Oklahoma, central and west Texas, and eastern New Mexico; also Arkansas, Louisiana, and east and south Texas.

Foredeep pools of South America include tertiary deposits in Ecuador, Colombia, Venezuela, and Trinidad. Less explored areas include those in Bolivia, Brazil, and Argentina.

Late Mesozoic deposits occur in Asia along the

eastern part of the Caspian Sea, in Iraq and Iran; and in Borneo and InrUa. Other areas include the deposits on Sakhalin and the Bahrein Islands, and along the east coast of Borneo. Oil seepages are numerous in China, but exploration has lagged and few fields have been developed. Tertiary dey-osits occur in Burma.

The only African oil regions are in the northwest along the Mediterranean, and in Egypt near the Gulf of Suez.

In Australia there are no clear evidences of petroleum deposits.

The projection map shown in Fig. 1 indicates the areas corresponding to the four principal petroleum basins of the world. This map does



FIG. 1.

not indicate the foredeep pools and minor producing areas.

PRODUCTION.

The rate of petroleum production has been increasing rapidly, owing to the great demands made by internal combustion engines and mechanised units of all descriptions. It may be safely asserted that all modern civilisation rests on adequate supplies of oil products, such as fuel for motors, lubricants, burning afid heating oils, waxes and asphalts. Table I shows production figures for various countries and districts of the world for 1944, and also the total cumulated production through that year.<sup>8</sup> Reliable estimates for 1945 are not available (Janf 1946). The United States has produced nearly two-thirds of the world's petroleum and is still producing the world's supply in about the same proportion. As to future production in different world areas, varying estimates are available.

Eugene Stebinger and L. G. Weeks have made a comparative analysis of oil-finding experience. Excluding areas of igneous and metamorphic rocks as impossible for the production of oil, and comparing only sedimentary areas on which oil might reasonably be expected, the United States (not including Alaska), with 2\*4 million square miles, accounts for 11% of the earth's sedimentary area favourable for oil. Of the land area of the United States 80% is composed of sedimentary rocks likely to contain oil, whereas for the earth as a whole less than 40% of the land area is of this character. Even so, if sedimentary rocks yielded oil uniformly over the earth the United States might expect ultimately to produce only 11% of the earth's total instead of 54%, its contribution to date.

TABLE I.—CUMULATED PRODUCTION THROUGH 1944.

Continent and country.	Annual production (thousands of barrels) 1944.	Year's production as per cent. of world total 1944.	Thousand barrels.	Per cent. of world cumulated production.
<i>North America.</i>				
Canada . . .	10,000	0-38	105,074	0-21
Mexico . . .	86,000	1-38	2,139,551	4-58
Trinidad . . .	25,000	0-95	297,494	0-68
United States . . .	1,678,264	64-01	129,776,731	83-54
Others . . .	200	0-01	1,225	0-00
<b>Total N.A.</b> . .	<b>1,749,404</b>	<b>66-73</b>	<b>32,320,075</b>	<b>69-36</b>
<i>South America.</i>				
Argentina . . .	24,200	0-92	320,433	0-69
Bolivia . . .	425	0-02	2,671	0-01
Colombia . . .	23,500	0-90	351,031	0-75
Ecuador . . .	2,500	0-10	33,739	0-07
Peru . . .	21,000	0-80	326,157	0-70
Venezuela . . .	267,000	10-18	2,890,087	6-20
Others . . .	50	0-00	123	0-00
<b>Total S.A.</b> . .	<b>338,675</b>	<b>12-92</b>	<b>3,924,241</b>	<b>8-42</b>
<i>Europe.</i>				
Albania . . .			8,068	0-01
Czechoslovakia . . .	125	0-01	3,036	0-00
England . . .	670	0-02	2,216	0-00
France . . .	500	0-02	13,243	0-02
Germany . . .	7,000	0-27	76,495	0-16
Austria . . .	6,000	0-23	21,802	0-04
Hungary . . .	7,500	0-29	26,836	0-05
Italy . . .	40	0-00	2,993	0-00
Poland . . .	3,500	0-13	276,514	0-59
Rumania . . .	30,000	0-76	1,046,140	2-24
U.S.S.R. (Russia) . . .	275,000	10-49	5,370,539	11-52
Others . . .		0-00	76	0-00
<b>Total Europe</b> . . .	<b>320,345</b>	<b>12-22</b>	<b>6,847,957</b>	<b>14-69</b>
<i>Africa.</i>				
Egypt . . .	9,000	0-34	78,205	0-17
Algeria . . .			143	0-00
Others . . .	25	0-00	213	0-00
<b>Total Africa</b> . . .	<b>0,025</b>	<b>0-34</b>	<b>78,561</b>	<b>0-17</b>
<i>Asia.</i>				
Bahrein Island . . .	8,750	0-33	68,293	0-15
Burma . . .	1,000	0-04	56,421	0-12
India, British . . .	3,000	0-12	267,919	0-67
Iran (Persia) . . .	102,000	3-89	1,350,832	2-90
Iraq . . .	33,000	1-26	279,701	0-60
Japan (including Taiwan) . . .	3,500	0-14	96,550	0-21
Netherland India . . .	35,000	1-33	1,102,807	2-37
Sakhalin . . .	5,500	0-21	55,740	0-12
British Borneo (Sarawak and Brunei) . . .	5,500	0-21	118,032	0-25
Saudi Arabia . . .	6,000	0-23	31,755	0-07
Others . . .	900	0-03	1,650	0-00
<b>Total Asia</b> . . .	<b>204,150</b>	<b>7-79</b>	<b>3,429,700</b>	<b>7-36</b>
Australia and New Zealand . . .	50	0-00	107	0-00
World, undistributed . . .	25	0-00	1,123	0-00
<b>World total</b> . . .	<b>2,621,734</b>	<b>100-00</b>	<b>46,601,764</b>	<b>100-00</b>
<i>Data by global units.</i>				
West hemisphere . . .	2,097,164	80-00	36,322,877	77-94
Europe (including Middle East) . . .	320,345	12-22	6,847,957	14-70
Middle East . . .	149,750	5-71	1,730,581	3-72
Far East . . .	53,500	2-04	1,097,469	2-36
Others . . .	975	0-03	2,860	0-00
<b>Total</b> . . .	<b>2,621,734</b>	<b>100-00</b>	<b>46,601,764</b>	<b>100-00</b>

Stebinger and Weeks have classified sedimentary areas still further as to their promise for oil, retaining for consideration only the more favourable areas where marine sediments occur in thick section over extensive basins. Of these favourable areas the United States is found to have about 0.9 million square miles, or 15% of the known total of 6 million for the earth. It appears from their study that 38% of the sedimentary area of the United States is favourable for oil, whereas, excluding the United States, only 27% of the earth's sedimentary area is favourable for oil. If the promising sedimentary rocks prove to be equally productive over the earth, the United States will ultimately produce only about 15% of the earth's oil.<sup>13</sup>

Table II shows the areas of the world classified as to their future oil prospects.<sup>14</sup> In designating the petroleum reserves of the world, the limitations of the word "reserves" need defining. "Proved reserves" is a narrow term meaning only that part of petroleum discovered by actual drilling which is recoverable by present operating methods under existing economic conditions. Proved reserves do not include (1) oil under the unproved portions of partly developed fields; (2) oil in untested prospects; (3) oil that may be present in unknown prospects in regions believed to be generally favourable; (4) casing head gasoline extracted at natural gasoline plants in moderately low-pressure fields; (5) oil that may become available by secondary-recovery methods from fields where such methods have not yet been applied; (6) oil that may become available through chemical processing of natural gas; (7) oil that can be synthetically recovered from oil shale, coal, or other substitutes.<sup>16</sup> Proved reserves is the narrowest definition. The word "reserves," referring to the oil actually found by drilling and recoverable by such secondary methods as flooding and repressuring with gas covers about twice as much oil as that referred to under the term "proved reserves." "Petroleum resources" is still broader in its meaning and refers to the total oil probably recoverable by any method, not only from areas proved by drilling but also from areas favourable to oil accumulations and the oil equivalent of all source materials which can be converted into liquid fuels. These sources include natural hydrocarbon gas, oil shales, tar sands, and coal.

#### COMPOSITION OF PETROLEUMS.

Petroleum from different parts of the world are extremely variable in chemical composition. They contain varying proportions of paraffin, naphthene, and aromatic hydrocarbons, and apparently small amounts of unsaturates such as olefins and terpenes, although the presence of the last two groups in crude oils has sometimes been a matter of controversy. Compounds are present which contain, in addition to carbon and hydrogen, sulphur, nitrogen, and oxygen, and small amounts of inorganic components are present. The non-hydrocarbon constituents are in minor proportions so that the average petroleum is predominately a mixture of hydrocarbons of varying molecular structure, molecular weight, and boiling-point. In the lighter fractions of petroleum of relatively low specific

gravity, paraffin hydrocarbons predominate, and as the specific gravities of whole petroleum or their fractions increase, the percentages of

TABLE II.—AREAS OF WORLD CLASSIFIED AS TO FUTURE PROSPECTS FOR OIL.

	Very great.	Large.	Locally important.	Small.
North America.				
U.S. A.				
Gulf Coast . . . . .	+			
Mid continent (including West Texas and New Mexico) . . . . .	+			
Rocky Mountains California . . . . .		+		
Eastern Mexico . . . . .		+		
Canada . . . . .		«*		
Central America . . . . .				+
South America.				
Venezuela . . . . .	+			
Colombia . . . . .	+			
Peru . . . . .		+		
Ecuador . . . . .			+	
Paraguay . . . . .			+ 1	
Chile . . . . .				+
Argentina . . . . .			+	
Bolivia . . . . .			+	
Brazil . . . . .				+
Europe.				
England . . . . .				+
Sennas; France . . . . .			+	+
Italy . . . . .			+	+
Albania . . . . .			+	+
Poland . . . . .			+	+
Romania . . . . .		+		+
Spain . . . . .				+
Denmark . . . . .			+	+
Hungary . . . . .				+
Czechoslovakia . . . . .				+
Kishinev* . . . . .				+
Russia:				
Baku Region . . . . .	++			
North Caucasus . . . . .	+			
Perm Basin . . . . .	+			
Urals Region . . . . .		+		
Asia.				
Russia:				
East Ural . . . . .		+		
Sakhalin . . . . .		+		
North Arctic . . . . .			+	
Turkmen Kettle . . . . .	+			
Tajikistan and Kirgiz . . . . .		+		
Iran . . . . .	++			
Iraq . . . . .	+			
Arabia . . . . .	+			
Kuwait . . . . .		+		
Qatar . . . . .		+		
Syria . . . . .			+	
Bahrain . . . . .			+	
Turkey . . . . .				+
India . . . . .			+	
Afghanistan . . . . .			+	
Burma . . . . .			+	
Palestine . . . . .				+
Neth. East Indies . . . . .		+		
China . . . . .				+
Japan . . . . .				+
Australia . . . . .				+
Africa.				
Egypt . . . . .			+	
Libya . . . . .				+
Angola . . . . .				++
French North Africa . . . . .				++
Madagascar . . . . .				++

(Does not consider present discovered reserves.)

naphtheic and aromatic compounds and those containing sulphur, oxygen, and nitrogen usually increase.

The difficulty of separating individual hydrocarbons from petroleum limited for many years the production of chemical derivatives to those of the normally gaseous or low boiling liquid paraffins which have relatively few isomers. This contrasts with the derivatives of aromatic hydrocarbons produced from coal tar, wherein the base compounds benzene and toluene boil at 80° and 110°. (176° and 230°F.) respectively, and are easily separable. With improved fractionation more pure petroleum hydrocarbons are available, and an extensive chemical industry is developing which will eclipse that of coal tar.

The ordinary temperature-volume distillation curves of petroleum fractions show no sharp breaks or plateaux, but rather a gradually rising slope which indicates the presence of a large number of individual hydrocarbons. These curves show a downward inflection at the lower end and an upward inflection at the upper end,

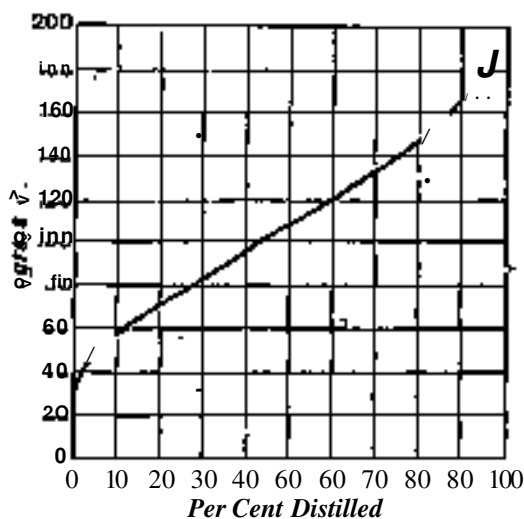

FIG. 2.

indicating a small amount of low boiling hydrocarbons and a correspondingly small amount of relatively high boiling compounds. Fig. 2 shows a typical distillation curve for a commercial motor gasoline " (U.S.A. 1944).

Separations of individual hydrocarbons in petroleum by distillation methods, even those of the most efficient type, are complicated by the existence of constant boiling-point mixtures of two or more hydrocarbons having different boiling-points, and the fact that compounds of widely different composition and molecular structure may have practically identical boiling-points. Then as the molecular weight and the number of isomers corresponding to a given number of carbon atoms increase, the differences in physical properties such as boiling-points and freezing-points become smaller and add to the separation difficulties.

The presence of paraffin, cycloparaffin, aromatic and olefin hydrocarbons in petroleum have been shown by the activities which whole petroleum or their fractions exhibit with chemical reagents. Thus fractions from Penn-

sylvania and most Michigan crude oils show little or no reaction with strong sulphuric acids, indicating that they contain relatively small amounts of olefins or aromatics and probably consist predominantly of paraffins and naphthenes. The same conclusion is deducible from the fact that chlorine or hydrogen chloride has substantially no effect on their primary distillate fractions at ordinary temperatures. Naphthenes are readily oxidised by fuming sulphuric acid at ordinary temperatures, and the presence of large proportions of these hydrocarbons in Californian, Gulf coastal, Russian, and some Rumanian oils is indicated by their vigorous reducing action on such acid, even after aromatics have first been removed. In Borneo the presence of aromatic hydrocarbons is indicated by their reactivity with 96% sulphuric acid and with nitrating mixtures. Cracked oils contain olefins which react with 87% or weaker sulphuric acid. The presence of aromatic and/or olefin hydrocarbons is also indicated by the action of ethyl alcohol, liquid sulphur dioxide, aniline, and other solvents having known selectivity for such hydrocarbons.

Using improved fractional distillation methods, the normally gaseous hydrocarbons methane, ethane, propane, and normal and *i*-butane have been separated in more or less pure condition from natural and refinery gases. The three five-carbon atom paraffins, *n*-pentane, *i*-pentane, and neopentane have been separated from low-boiling petroleum distillates in quantities decreasing in the order given. The *n*- and *iso*-compounds have been frequently isolated, but neopentane is present in such small quantities that its presence has only been proven by infrared spectrophotometry. It has been shown to be in fractions of both east and west Texas crudes. Natural gases are composed principally of hydrocarbons of which methane constitutes up to 98%. Some gases contain no non-hydrocarbon compounds, but others contain carbon dioxide, nitrogen, hydrogen sulphide, and helium.

The presence of many individual hydrocarbons from the different groups has been indicated in petroleum from all parts of the world. In many reported instances of the occurrences of individual hydrocarbons, quantitative data are lacking, but specific compounds are present in quantities less than 1%.

#### Paraffin Hydrocarbons

Paraffin hydrocarbons have been separated by fractionation of the liquids recovered by cooling, compressing or absorbing " wet " natural gases to produce " natural " or oil well " casing head " gasolines. In these gasolines, *n*-pentane, *w*-pentane, *w*-hexane, 2-methylpentane, *n*-heptane, 2-methylhexane and a mixture of octanes have been identified. In Table III a number of normally liquid paraffin hydrocarbons are listed, which have been reported by various investigators to occur in different crude oils.<sup>17</sup>

In addition to the hydrocarbons listed in the Table, higher molecular-weight paraffins containing from 13 to 22 carbon atoms per molecule have been indicated.



TABLE III.

$\text{CH}_3\text{.ECHJ}_3\text{.CH}_3$ n-Pentane.	$\text{CH}_3\text{CH}(\text{CH}_3)\text{.CH}_2\text{.CH}_3$ isoPentane.
$\text{C}(\text{CH}_3)_4$ ?isoPentane.	$\text{CH}_3[\text{CHJ}_4\text{.CH}_3$ n-Hexane.
$(\text{CH}_3)_2\text{CHCH}(\text{CH}_3)_2$ 2:3-Dimethylbutane(Tetramethylethane).	
$\text{CH}_3\text{CH}(\text{CH}_3)\text{.[CH}_2\text{]}_a\text{CH}_3$ 2-Methylpentane.	
$\text{CH}_8\text{CH}_2\text{CH}(\text{CH}_3)\text{CH}_2\text{CH}_8$ 3-Methylpentane.	
$(\text{CH}_3)_2\text{C.CH}_2\text{CH}_3$ 2:2-Dimethylbutane.	$\text{CH}_3[\text{CHJ}_5\text{.CH}_3$ n-Heptane.
$\text{CH}_3\text{CH}(\text{CH}_3)\text{.[CHJ}_3\text{CH}_3$ tooHeptane (2-methylhexane).	
$\text{CH}_8\text{CH}(\text{CH}_3)\text{CH}_2\text{CH}(\text{CH}_3)\text{.CH}_3$ 2:4-Dimethylpentane.	
$\text{CH}_8\text{C}(\text{CH}_3)_2[\text{CH}_2]_2\text{.CH}_3$ 2:2-Dimethylpentane.	
$(\text{CH}_3)_3\text{C}(\text{C}_5\text{H}_6)$ , 3:3-Dimethylpentane (Dimethyldiethylmethane.)	$\text{CH}_3\text{.CCHJe.CH}_3$ n-Octane.
$(\text{CH}_3)_2\text{CH}[\text{CHJ}_2\text{CH}(\text{CH}_3)_2$ 2:5-Dimethylhexane (Tetramethylbutane).	
$\text{CH}_3[\text{CHJ}_7\text{.CH}_8$ n-Nonane.	$\text{CH}_8[\text{CHJ}_8\text{.CH}_3$ n-Decane.
$(\text{CH}_3)_2\text{CH}[\text{CHJ}_4\text{.CH}(\text{CH}_3)_2$ 2:7-Dimethyloctane (Difsoamyl).	
$\text{W}1^{n}24$ Undecane.	$\wedge 12^{n}28$ Dodecane.

### Olefin Hydrocarbons.

The presence of olefins in petroleum oils has been reported by many investigators,<sup>18</sup> but whether these hydrocarbons were present in the original erode oils and not formed by decomposition reactions during their distillation is still a matter of dispute. Some crude oils have been reported to contain no olefins and others have been stated to contain amylene, hexylene, heptylenes, octylenes, nonylenes, and mono-olefins of higher molecular weight, up to 13 carbon atoms per molecule. The latest researches indicate that if olefins are present they are only in very small amounts.

### Naphthenes.

This group of hydrocarbons is one of the most important in petroleum and its fractions.<sup>19</sup> Representatives occur in all petroleum, the proportions being lower in the so-called paraffinic petroleum, and higher in those of the naphthenic or asphaltic type. The lower boiling liquid portions of petroleum such as gasolines

and naphthas are essentially mixtures of paraffin and naphthenic hydrocarbons. While only limited data are available on the actual percentage of naphthene hydrocarbons, many have been positively identified, and Table IV gives a list of some of them:

TABLE IV.

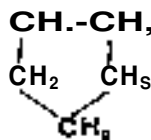
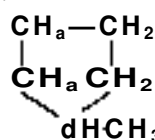
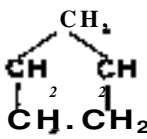
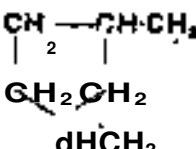
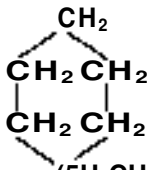
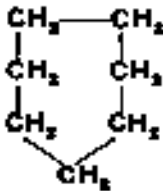
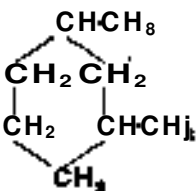
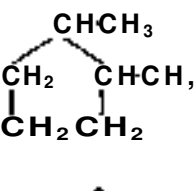
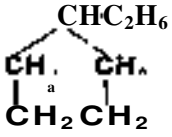
 cycZoPentane.	 MethylcycZopentane.
 cycZoHexane.	 1:3-Dimethylci/c/o-pentane.
 Methylcyclohexane.	 cycZoHeptane.
 1:3-Dimethylcyclohexane.	 1:2-Dimethylcyclohexane.
 Ethylcyclohexane.	
$\text{C}_9\text{H}_{18}$ 1:2:4-Trimethylcyclohexane (Hexahydroseudocumene).	$\text{C}_{10}\text{H}_{20}$ isoDecanaphthene.
$\text{C}_{10}\text{H}_{20}$ a-Decanaphthene.	$\text{C}_{10}\text{H}_{20}$ /J-Decanaphthene.
$\text{C}_{11}\text{H}_{22}$ Undecanaphthene.	$\text{C}_{12}\text{H}_{24}$ Dodecanaphthene.
$\text{C}_{14}\text{H}_{28}$ Tetradecanaphthene.	$\text{C}_{16}\text{H}_{30}$ Pentadecanaphthene.

A number of other higher molecular weight saturated hydrocarbons having the general formula  $\text{C}_n\text{H}_{2n}$  have been identified in various petroleum. These hydrocarbons have from 11

to 26 carbon atoms per molecule. In most cases their structure is incompletely known, but they are presumably ring compounds.<sup>3</sup>

**Terpenes.**

The presence of terpenes in Gaician oils has been reported, these compounds having the general formula,  $C_nH_{2n-4}$ .<sup>20</sup> However, some doubt is cast upon these assertions by recent investigators.

**Aromatics.**

These hydrocarbons are present in a variety of petroleum, although in small amounts in most of them.<sup>21</sup> In uncracked gasolines the percentage of aromatic hydrocarbons is usually low, less than 5% in most cases. In some exceptional crude oils, such as those from Borneo, the percentage of aromatic hydrocarbons in the lower boiling distillates is high, sometimes over 15%. Table V lists aromatic hydrocarbons which have been proved to be present in petroleum from various localities.

No systematic attempt was made to analyse liquid petroleum fractions and separate the individual hydrocarbons which they contained until the instigation of the American Petroleum Institute Research Project in 1927.<sup>22</sup> Research under this sponsorship has actually isolated the majority of hydrocarbons present in the lighter fractions of several United States petroleum. Physical methods alone involving precise fractional distillation, fractional crystallisation, solvent extraction, and selective absorption have been employed. The methods are briefly summarised below:

**1. Fractional Distillation:**

- (a) At a fixed pressure (separates hydrocarbons according to size of molecules).
- (b) Under varying pressures (use of subatmospheric pressures permits separation of different types of molecules).
- (c) With addition of substances forming constant-boiling mixtures.

**\*. Fractional Crystallisation (more symmetrical molecules have higher melting-points):**

- (a) Simple refrigeration.
- (b) Refrigeration in an appropriate solvent.
- (c) With centrifuging.

**3. Extraction with Selective Solvents:**

- (a) Use of different solvents,
- (b) Variation of temperatures of extraction.

**4. Adsorption:**

- (a) Use of different adsorbents,
- (b) Use of different temperatures.

These investigations have shown that the lower-boiling petroleum fractions are essentially paraffinic, that the proportions of cyclic hydrocarbons increase with the boiling-point; and that a large percentage of the compounds in the higher-boiling fractions are poly cyclic, the rings joining in their degree of hydrogenation and being extensively substituted by alkyl groups.

TABLE V.

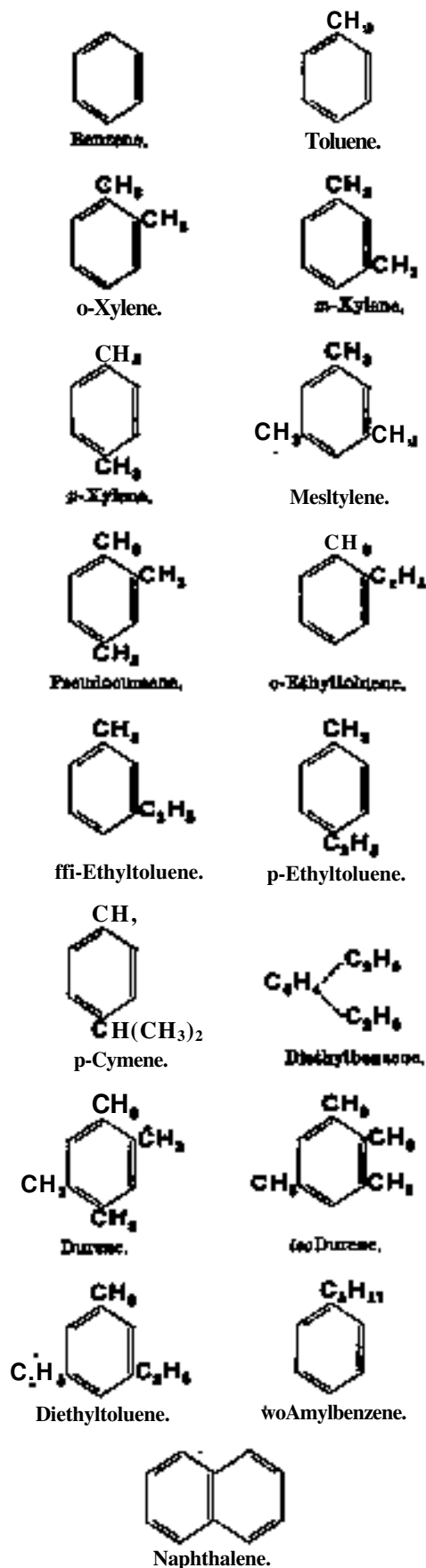

Details on the hydrocarbons found in petroleum by the American Petroleum Institute Hydrocarbon Research Project are given under the headings of motor fuel, kerosene, gas oil, lubricating oils, and asphalt in the products section.

### Non-Hydrocarbon Constituents.

#### *Sulphur Compounds.*

Of the minor organic constituents of petroleum containing sulphur, nitrogen, and oxygen, the sulphur compounds may be considered as the most important of the three groups, since they occur in greatest quantity and frequently have the greatest effects upon the properties of the oil.<sup>23</sup> The best explanation of the presence of sulphur is that it was originally contained in the marine organisms from which petroleum is presumed to have been derived by gradual decomposition of their remains. Several secondary sources appear as possibilities. Some sulphur may have been dissolved during the migration of the oil through sulphur-containing formations, when sulphur compounds could have been formed by reaction of the hydrocarbons with the sulphur, or by reducing action of the oil upon sulphates such as gypsum. Free sulphur is sometimes found in solution in petroleum, though the major amount is usually in combination.

The sulphur content of various petroleum oils varies over wide ranges. In paraffinic petroleum, such as those from Pennsylvanian fields, it is usually below 0.1% and may be as low as 0.01%. The largest sulphur contents are usually associated with heavier crudes of a naphthenic or asphaltic character such as the Mexican or Californian crudes. In these latter types it is not uncommon to find values of the order of 5%.

In petroleum or fractions therefrom which have not been heated to cracking temperatures, indications are that they contain elemental sulphur, alkyl sulphates, and hydrogenated thiophenes or "thiophanes." When oils containing free sulphur are heated, the sulphur reacts with the hydrocarbons and forms hydrogen sulphide and mercaptans. The heavier cyclic compounds in which the sulphur is present in the polymethylene rings evidently decompose to form hydrogen sulphide, alkyl sulphides, and both lighter and heavier cyclic compounds in a manner analogous to the cracking of a hydrocarbon fraction to form both lighter and heavier products.

#### *Nitrogen Compounds.*

The amount of nitrogen present in petroleum varies over wide ranges, and some petroleum, particularly those of a more or less paraffinic character, have been shown by analysis to contain such extremely small amounts of nitrogen that it has been questioned whether nitrogen is actually present or the analysis is in error.<sup>24</sup> In Pennsylvanian petroleum the total nitrogen content has been reported to be about 0.008%. Californian oils contain the most nitrogen found in American petroleum, the maximum being 0.82%. As regards the upper limit of nitrogen content, analyses of some oils have indicated as high as 2% by weight, which would correspond

to 10-15% by volume of nitrogen compounds. The presence of nitrogen in petroleum has a bearing on theories regarding its origin, since nitrogen is a characteristic constituent of proteins which are characteristically higher in animal than in vegetable remains. The nitrogen content is highest in petroleum containing cyclic hydrocarbons in predominating amounts, such as Californian, Mexican, and South American crudes, while the content is least in paraffinic petroleum, such as those from the Pennsylvania and Michigan districts.

Early researches on the character of the original nitrogen compounds present in crude petroleum indicated that they are compounds having a polynuclear structure similar to that of quinoline. In crude petroleum containing considerable percentages of nitrogen, nitrogen compounds are first identified in the kerosenes, and analyses of close cut fractions indicate that there is frequently an uneven distribution. Little is known of the precise structure of these nitrogen compounds. The bases encountered in the distillates from Californian oils are evidently decomposition products of more complex nitrogen compounds present in the original crude. Some of the compounds are non-reactive with dilute mineral acids. In a kerosene distillate from Californian petroleum the following quinoline homologues have been found:

Quinoline.  
 tffoQuinoline.  
 2:3-Dimethylquinoline.  
 2:4-Dimethylquinoline.  
 2:8-Dimethylquinoline.  
 2:3:8-Trimethylquinoline.  
 2:4:8-Tetramethylquinoline.  
 Quinaldine.  
 Lepidine.

Some of the compounds in Californian kerosene distillate are apparently cyclic tertiary amines. One has the composition  $C_{13}H_{21}N$ , and another  $C_{16}H_{31}N$ . The second compound has been reduced to a secondary amine having the formula  $C_{16}H_{31}N$ .

When petroleum fractions such as the heavier distillates or residua are cracked, such nitrogen compounds decompose and yield products formed by loss of hydrogen and splitting off of alkyl groups. The gases from cracking such stocks contain ammonia. Apparently there is very little break-up of the ring structures to form amines. A small amount of basic materials extracted from a cracked gasoline made from Californian gas oil and residuum showed the presence of quinoline, quinaldine, and seven alkyl substituted pyridines, as follows: 2-methylpyridine, 4-methylpyridine, 2:6-dimethylpyridine, 2:5-dimethylpyridine, 2:4-dimethylpyridine, 3:5-dimethylpyridine, and 2:4:6-trimethylpyridine.

#### *Oxygen Compounds.*

Compounds containing oxygen are present in most petroleum in minor proportions, so that they may perhaps be looked upon as the least important of the non-hydrocarbon constituents.<sup>28</sup> However, some of these compounds

have found commercial uses and merit consideration.

The oxygen-containing compounds in petroleum have been shown to be principally acid compounds containing the carboxyl group. Since the first compounds of this character which were separated from petroleum and positively identified contained the six carbon atom *cycloparaffin* grouping which characterises the hydrocarbons commonly designated as naphthenes, the compounds have since been customarily referred to as naphthenic acids, but some are acids of straight chain molecular configurations which are properly classed as aliphatic.

As to the molecular structures of the naphthenic acids, some of the carbon-hydrogen groupings attached to the carboxyl groups are of a saturated character, while others are unsaturated. Apparently the saturated compounds in the lower tailing fractions of petroleum have either six or seven carbon atoms in their structure, including the carbon atom present in the carboxyl group. The acids characterised by having one double bond are in the next higher boiling fractions and apparently contain from eight to twelve carbon atoms.

Still heavier fractions contain acids characterised by two double bonds in the carbon-hydrogen group. The exact arrangement of the carbon atoms in the aliphatic acid molecules is not well known. Some may have the carbon atoms in straight chain arrangement and others may be characterised by extensive branching.

The naphthenic acid content of various petroleum is generally a rather uncertain quantity because they are seldom recovered in pure condition but are usually contaminated with hydrocarbons. Analyses have been reported showing from 0.03% to as high as 3% naphthenic acids, and the average of all petroleum analysed seems to be something less than 1%. It is noted in general that petroleum which are essentially paraffinic in character contain the least amount of the acids, whilst those which are characterised by the higher percentages of cyclic hydrocarbons contain greater quantities of acids. Thus certain Californian naphthenic crudes have shown as high as 3%, and similar types of crude oils from Kumania have shown over 2%.

Naphthenic acids are readily extracted from hydrocarbon fractions by the use of sodium carbonate, which reacts with the acids to form soaps but not with phenols, which require a stronger alkaline reagent such as sodium hydroxide for their extraction. The naphthenic acids themselves can be recovered by the acidification of the soaps with strong mineral acids.

The lower molecular weight naphthenic acids are colourless liquids and those with higher molecular weight have a slightly yellowish tinge. They are very difficult to purify and separate completely from hydrocarbons with which they have been associated. The recovered acids form salts with various metals such as calcium, aluminium, and copper, the copper salts having a beautiful green colour when dissolved in benzene. Many of the compounds of naphthenic acids with metals are used as insulating materials, adhesives, and varnish substitutes. The copper salts have antiseptic properties and are used as

wood preservatives, and cobalt, manganese, and lead salts function as driers in paints and varnishes.

The acids are toxic to bacteria, fish, and some amphibians, but are not particularly toxic to larger animals or to human beings.

It has been shown that the naphthenic acids encountered in petroleum distillates are principally those, originally present in the oils and that they have not been produced by oxidation reactions incidental to chemical treatments such as those using sulphuric acid. There is some evidence to indicate that some of the higher molecular weight naphthenic acids are decomposed during cracking to form lighter acids such as the previously mentioned aliphatic compounds. Acetaldehyde has been reported in some Pennsylvanian oils and compounds showing the reactions of alcohols, aldehydes, and ketones have been reported in heavy lubricating oils.

Mixtures of phenols have been shown to be present in distillates from American, Japanese, and Polish, crude oils. Cresols, xylenols, di- and tri-ethyl phenols, and o-naphthol have been identified. The undistilled crude oils investigated showed less phenolic compounds than the distillates, and since the amounts of phenols were much higher in cracked distillates, the conclusion is that the major amounts of phenols are the result of cracking reactions. The recovery of cresols from Californian cracked distillates is a commercial process even though the content is small, usually around 0.01%. Phenols from cracked distillates are sold as disinfectants and wood preservatives, and for other purposes for which high-boiling tar acids are used. Products approximating 95% cresylic acid are recovered from low-boiling cracked distillates. Table VI shows the properties of petroleum cresylic acids compared with those of ordinary commercial grade.<sup>27</sup>

TABLE VI.—ANALYSIS OF CRESYLIC ACIDS.

Tests.	Petroleum cresylic acids.	Purchased cresylic acids.
Sp. gr. at 15.5°/15.5°0.	1.014	1.032
(60°/60° F.)		
Water by distn., %	0.3	0.0
Tar acids, %	0.6-2	0.8-6
Neutral oil, %	3.5	0.5
Sulphur, %	1.5	0.22
Phenol coefficient	21	8
Naphthenic acids, %	15	Nil
Solubility in NaOH	Complete.	Complete.
Distillation:	°C °F.	°C °F.
Initial b.p.	185 365	182 360
10% over	206 402	199 391
50% "	219 426	208 406
90% "	277 530	264 508
End point	284 544	287 548
Colour reaction:		
Bromine water	Whitish ppt.	Creamy ppt.
Ferric chloride	Bluish green.	Bluish green.
Chloroform and KOH	Dark red.	Dark red.
Ammonia and sodium hypochlorite	Greenish blue.	Greenish.

Certain natural asphalt deposits contain as much as 14-15% oxygen.<sup>28</sup> The nature of the

oxygen compounds is so complex that little progress has been made in determining their structure. On the theory that such natural asphalts are residues from petroleum which originally contained lower boiling and normally liquid fractions, it probably can be assumed that the oxygen present in the original petroleum has been concentrated in the residua and that it may have played an active part in the formation of the asphalt. In support of this hypothesis is the fact that petroleum residua can be oxidised at moderate temperatures of the order of 260° (500°F.) by passing air through them. This treatment introduces oxygen into the original oils, raises the melting-point of the material, and produces both water and lower boiling aliphatic and naphthenic acids.

#### *Inorganic Constituents.*

Many petroleum contain minor amounts of inorganic substances which form ash when the oils are burned.<sup>29</sup> In the lighter and less viscous oils the ash content may be very small, while in the heavier oils it may assume considerable importance. In some cases the non-combustible residues left on burning petroleum are so small that it is difficult to say whether they were originally present in the oil as obtained from the earth or whether they have arisen through accidental contamination by contact with pipes and tanks or by the conveyance of various wind-blown dusts. The ashes from oil crude oils contain appreciable amounts of silica and the oxides of iron, aluminium, and titanium as well as those of calcium and magnesium, all of which accompany silica in earthy matters. The silica content of petroleum ashes varies from less than 1% to somewhat over 50% and the combined oxides of iron, aluminium, calcium, and magnesium have varied from less than 10% to nearly 100% of the ash. These occurrences can be accounted for on a basis of the subterranean contacts of the oil with various rock formations.

There are, however, certain mineral substances present in petroleum which are not as easily accounted for, but which appear to have more of a relation to the origin of the oil. One of these anomalous constituents is vanadium oxide which has been shown to be present in practically all petroleum ashes from a detectable trace to as high as 40%. The occurrence of this substance is not particularly characteristic of any given oil-producing area, which favours the assumption that its presence is broadly related to the method of formation or the origin of the oils. Since it is known that vanadium compounds characterise various land and marine animals and plants, its presence in petroleum would seem to add weight to the theory that petroleum originated by the decomposition of such living organisms. The presence of vanadium in fuel oils used for firing glass-making industries is frequently deleterious, since the glass may be defective owing to the introduction of vanadium compounds.

Owing to the industrial uses of vanadium, its recovery from petroleum has commercial aspects. Thus vanadium-containing dusts are recovered from flue gases from furnaces burning fuel oils containing compounds of this element. Vanadium

oxides have been shown to be good dehydrogenating catalysts for hydrocarbons, and thus it appears that nature has furnished in some instances both hydrocarbons and catalysts for their conversion all in one package. Vanadium oxide is also used as a catalyst in sulphuric acid manufacture, and the metal is a valuable ingredient in various ferrous and non-ferrous alloys in which it increases their toughness and resistance to shocks and varying stresses.

The vanadium content of petroleum ashes seems to be higher in the heavier more asphaltic oil and lower in the non-asphaltic types. Vanadium compounds have also been shown to be present in oil shales of Scotland and in the ashes of various coals and lignites.

In many cases the ash-making constituents are not readily removable by mechanical filtration, which indicates that the inorganic constituents are either present in oil-soluble compounds or that they are suspended in an extremely fine state of subdivision so that they pass through the pores of the filter material.

Another element which is frequently found in petroleum ashes is nickel, and it has been suggested that the presence of traces of this element has modified the character of some petroleum by catalysing various conversions involving hydrogen transfer reactions. However, it hardly seems possible that such nickel could function in this manner, since when nickel is employed as a catalyst in hydrocarbon conversion processes, such as cracking or hydrogenation, it is necessary for it to be in a finely divided and active metallic state, whereas there is no evidence to indicate that it is present in natural petroleum in this form. Nickel has been shown to be present in ashes obtained from seaweed, and since the most generally accepted theory on the origin of petroleum relates them to marine accumulations, the occurrence of nickel gives added weight to the marine origin theory.

Other unusual constituents of petroleum ashes include compounds of molybdenum, another metal used to toughen steels, and compounds of zinc. However, the amounts of these elements found in petroleum ashes are extremely small and have no commercial significance. Elements that have been found in traces in the ashes from crude oils include gold, silver, copper, tin, lead, cobalt, manganese, chromium, arsenic, barium, strontium, sodium, potassium, phosphorus, nitrogen, and sulphur. The quantities present are not sufficient to indicate any commercial possibilities.

Some ashes from petroleum, particularly those from Iranian crude oils, have shown small but definite radioactivity. Similarly, such activity has sometimes been exhibited by the substances dissolved in the waters associated with petroleum.

#### REFINING.

Refining in the case of petroleum includes any processing applied to the crude oil to separate it into different portions, to improve the crude oil as a whole or to alter the characteristics of its fractions. The primary process in refining is fractional distillation, whereby lighter and heavier portions are separated and gas, gasoline,

fuel oils, lubricants, wax distillates, and asphalts are produced. The properties of these primary products are modified by various types of chemical treatment, the use of specific solid absorbents for decolorising and deodorising, and selective solvent action for removing and segregating hydrocarbon groups and impurities. Processes whereby whole crudes or their fractions are decomposed by heat to produce lower-boiling products may be broadly grouped under the heading of cracking. The term treating is commonly applied to three types of processes:

- (i) Those which improve the stock by removal of undesired constituents.
- (ii) Those which effect an improvement in quality by the addition of extraneous materials, either by chemical combination or by solution.
- (iii) Those which alter the essential chemical structure of the hydrocarbons or other constituents of the oil fraction treated.

Refining methods will therefore be grouped as follows:

1. Fractional distillation.
2. Cracking.
3. Treating.

A general discussion of treating methods precedes the products section and specific methods of treatment will be referred to under product headings.

The first petroleum which were obtained from natural seepages or pits were generally used without special treatment, the uses to which they were put varying with their properties. Some were used as oil for crude lamps, and others as fuel for heating and cooking and for cleaning purposes. The asphaltic oils, many of which were found in Persia, were used for caulking boat seams, and in embalming. Some of the oils, were used in the treatment of skin diseases, and taken internally. Crude oils were, sometimes weathered to evaporate light constituents before use. Many crude distillation attempts were made in the Middle Ages, and about two hundred years ago a Russian obtained a lamp oil by distilling Caucasian petroleum.<sup>30</sup>

Early refining processes took advantage of the varying boiling-points of the constituents of oils to produce light distillates which could be used in lamps for illuminating purposes to take the place of whale and fish oils and oils made by distilling coal and shales. In 1855 the first still used in the United States for making petroleum products in commercial quantities was operated by Samuel Kier in Pittsburgh, Pennsylvania (four years prior to Drake's discovery well in 1859), using petroleum encountered in drilled salt wells.<sup>30</sup> Kier's still was of the vertical, cylindrical type with a capacity of about a barrel a day. Kerosene selling for \$1.25 a gallon was produced from this small refinery. With the advent of greater supplies of petroleum from Drake's and other wells, refining operations were conducted using similar stills of larger capacity which came to be known as "cheese-box" stills, some of these holding as much as 1,200 barrels of charge. This type of still persisted for many years, some being in operation as late as 1915.<sup>31</sup>

In the early refineries the gasoline obtained as a primary distillate was wasted by burning or running into rivers, and all efforts were directed to obtain maximum yields of kerosene as the principal marketable product. The unvaporised portions of the crude oil remaining in the stills were marketed as lubricants. Fortunately there were no asphaltic constituents in Pennsylvanian oils to complicate these relatively simple refining operations.

The early crudes contained wax which appeared in the heavier distillates and was recovered from them by chilling and filter pressing. Later the crude waxes were "sweated" by slowly heating a wax cake on a screen so that oil and low-melting waxes dripped from the crystals and higher melting-point waxes were obtained. The colour of the wax was improved by percolation of the melted material through granular charcoal or fuller's earths. Similar filtering processes were practised on some of the lubricating oils to lighten their colour.

DISTILLATION.

Figs. 3, 4, 5, 6, 7, 8, and 9 show some of the stages in the development of petroleum distilling equipment. Fig. 3 shows the essential parts of the so-called "cheese-box" still. Fig. 4 indicates an early horizontal cylindrical still equipped

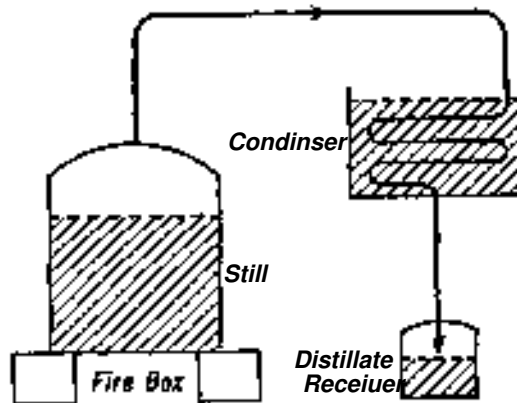

FIG. 3.

with a perforated line for the admission of steam under the surface of the oil. The small dome on top of the still functioned principally to prevent carry-over of liquid particles mechanically entrained in the vapours so that the distillates would not be contaminated. As the distillates increased in boiling-point and specific gravity, they were run into successive receiving tanks. Fig. 5 shows a horizontal still provided with a fractionating column, which represents the first attempts at more accurate fractionation. Early Columns were filled with crushed brick, gravel or silica fragments, and later with different types of spaced perforated metal plates. Many types of specially formed filling materials have been designed and used. Examples are short hollow cylindrical metal pieces, and spirato, such as the commonly used Raschig rings, made of earthenware. Rotating plates which throw condensed liquid on to the inner wall of the fractionating column have met with some success in improving the degree of fractionation.

Until about 1910, operations in petroleum refining were essentially unchanged, except for minor improvements. The older types of relatively flat, vertical, cylindrical stills were gradually replaced by long horizontal cylindrical

types, and continuous battery operation was practised in which four or five stills discharged their condensates (gasoline, kerosene, gas oils, and lubricating oil distillates) into separate tanks. In some arrangements (Fig. 6) crude oil

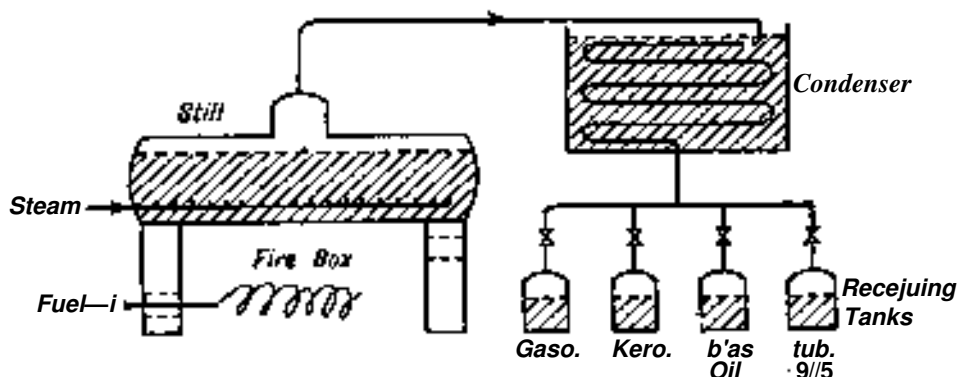

FIG. 4.

was fed into the first of a series of stills from which gasoline was distilled and condensed. The crude oil was admitted at one end of the still and allowed to overflow at the other end

into a second still heated at a higher temperature to distill off kerosene, the residue from this still was passed to a third unit and heated at a higher temperature for distilling gas-oil distillates; and

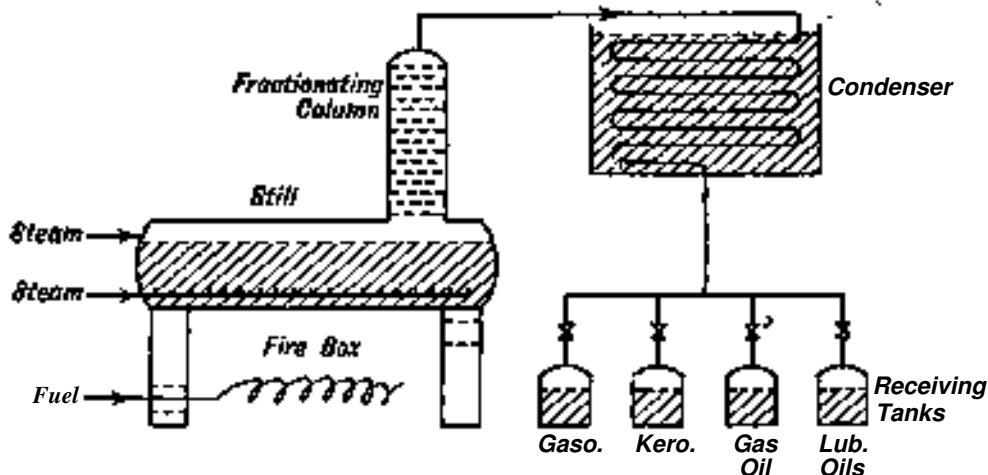

FIG. 5.

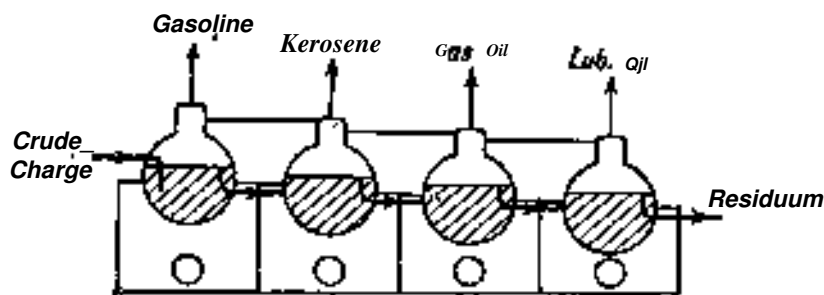

FIG. 6.

from the last still of the series lubricating oils were obtained. As the heavier distillates were recovered, steam was admitted under the surface of the oil to reduce the partial pressure of the oil vapours and assist in vaporising and preventing run-back, and the amount of steam and its

degree of superheat were increased as the boiling-point of the successive distillates became higher.

Fig. 7 represents a battery of stills for continuous operation, each still being separately heated and provided with a fractionating column for the production of a distillate product



of more closely defined boiling range.<sup>82</sup> The crude oil is continuously fed into the fractionating column on the first still in the series to produce gasoline as an overhead product. The residual oil is pumped into the fractionating column on the second still for the production of kerosene, and the residue from this unit is pumped to the final still of the series which is heated sufficiently to distil off a gas-oil distillate. The residue from the third still shown may be further distilled in a fourth unit, or one separate from the battery to recover paraffin or lubricating oil distillates from the fuel-oil residue. In the distillation of lubricating fractions either

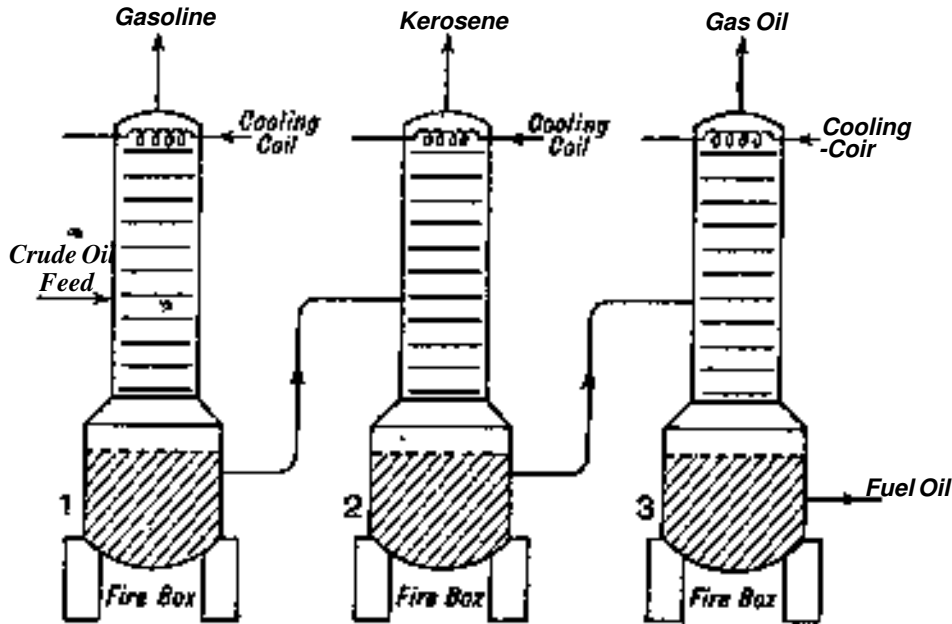

FIG. 7.

steam or reduced pressure is employed to lower the vaporisation points of the oils and lessen decomposition.

Fig. 8 shows a distilling arrangement for "flash topping" in which the crude oil is heated during its passage through a pipe still to a temperature high enough to vaporise all components but

residual fuel-oil, which is recovered from the bottom of the first fractionating column.<sup>88</sup> The vapours from the primary column then pass to a second column, the higher boiling-point gas-oil vapours being condensed and discharged from the bottom of the column, while the mixed vapours of gasoline and kerosene boiling-range

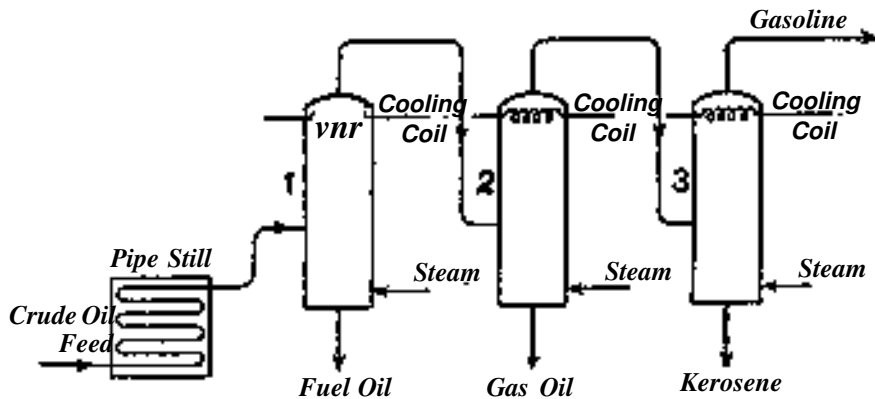

FIG. 8.

pass to a final fractionating column in which kerosene vapours condense, and gasoline vapours pass from the top of the column to a separate condenser.

The cooling coils through which water or charging oil is passed are situated in the top of the fractionating columns to control the

boiling range of the effluent vapours, and steam is usually introduced near the bottom of the columns for its partial pressure effect. Heat exchangers, pumps, and condensers have been omitted from Figs. 7 and 8, although these are standard equipment.

Fig. 9 shows the essential parts of a modern

topping still which is in effect a series of super-imposed fractionating columns. The crude oil is pumped through a pipe still in which it is heated to a temperature in the neighbourhood of 316-371° C. (600-700°F.), sufficient to vaporise all components except the desired residuum, the total products from the pipe still being admitted to the lowest section 1 of the fractionating column. The residuum is recovered from the bottom of the column and the vaporised portions of the heated product pass into section 2, which is divided from the first by a collecting plate A. In section 2, high-boiling vapours condense and form a pool of liquid on the plate, while lighter vapours pass upwardly through the centre of plate B to the top section 3 of the column. Gasoline boiling-range vapours issue from the top of the column, while a kerosene condensate is

recovered from plate B, and a gas-oil condensate from plate A. To conserve heat and assist in fractionating the vapours in the column, the crude oil feed is passed successively through closed pipe coils in the upper portions of the three sections of the column and then through a heat exchanger where it receives heat from the residuum before passing to the pipe still.

As a further aid to the production of fractions of more closely defined boiling-range, the accumulated liquids on plates A and B flow to auxiliary fractionating columns C and D, known as "stripper columns" into which steam is passed to vaporise the desired light distillates, while the heavier unvaporised portions return to the next lower section of the main column for further fractionation and their refluxing action. A portion of the condensed gasoline is pumped

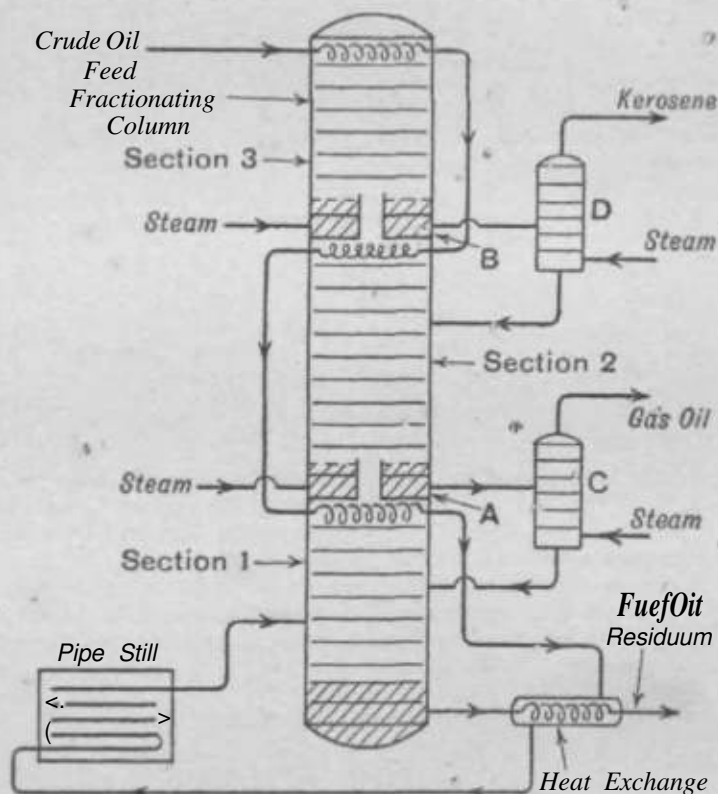

Fig. 9.

back into the top of section 3 to control the boiling range of the effluent gasoline vapours. In some commercial plants as many as eight different fractions are taken off at different levels.

In the modern fractionating columns so-called bubble trays are used. These have multiple vapour ports which support caps of different design to break up the vapours into small bubbles as they pass through the layer of liquid on the plate and promote vapour-liquid equilibrium by this intimate contact. Fig. 10 shows some of the detail of a bubble tray in a fractionating column of the bubble-cap type.<sup>86</sup> The liquid phase from the plate above flows across the plate shown in the diagram from left to right, encountering weirs on either side. Vapours from a plate below pass upward through risers and out through slots in the bubble caps, thus

assuring effective contact and establishment of liquid-vapour equilibrium.

The combination of pipe still and fractionating column is the major distilling development of the petroleum industry. Operations are continuous over long periods of time and many units have capacities of more than 25,000 barrels of crude oil a day. This type of fractional distillation is used to "stabilise" high vapour-pressure gasolines to remove dissolved gaseous hydrocarbons and retain only those necessary for imparting correct vapour pressure. Similar installations are employed to fractionate normally gaseous hydrocarbon mixtures, operations being conducted under pressures at ordinary or slightly elevated temperatures in lieu of operating at sub-atmospheric temperatures while utilising refrigeration.

In the most modern plants greatly improved fractionating columns are employed, which are commonly called superfractionators because of their ability to effect fine separations. Features of these fractionators include automatic controls of temperature, pressure, and reflux rates and thorough insulation. Pressure control and complete insulation eliminate any possible irregularity due to external atmospheric influences.

Table VII shows data on the properties of crude oils from different world-producing areas and indicates the wide variations encountered.<sup>86</sup> In the selected analyses the specific gravity varies from 0.9759 in the second California! crude

oil to 0.800 in the first oil from Sumatra. The pour points vary from -32° to +27° o. (-25° to +80° F.), and total sulphur from 0.05% in the Ecuadorian crude to 3.67% in the first Mexican crude. Gasoline recoverable by primary distillation of the third Russian crude is only 0.5%, while the crude oil from the Kettleman field in California contains 73.9% gasoline. Similarly, the amounts of kerosene, gas oil, lubricating oil, and residuum show marked differences.

Table VIII shows the percentage yields of major products from crude petroleum in the United States in 1944, the figures being average for all crude run to stills.<sup>87</sup> The high percentage

TABLE VII.—PROPERTIES OF CRUDE PETROLEUMS.

Country or State.	Field.	A.P.I. gr.	Sp.gr.	Pour point, F.	Sulphur, wt. %.	Volume %.				
						Motor gas-oil.	Kero-sene.	Gas oil.	Lubri-cating oil.	Residu-um.
<i>North America.</i>										
Oklahoma	Oklahoma City	37.8	0.8265	+5	0.21	25.1	14.9	11.2	—	48.6
Oklahoma	Tonkawa	42.8	0.8118	+20	0.18	37.9	20.7	11.3	—	29.9
Kansas	McPherson	36.8	0.8408	+5	0.28	23.9	16.7	14.3	—	44.9
Kansas	McPherson	32.5	0.8628	+15	0.52	20.6	16.9	10.0	—	52.2
Texas West Central	Stevens	33.8	0.8560	10	0.22	14.8	—	30.9	—	54.3
Texas West Centr&l	Shackelford	40.3	0.8236	-2.5	0.33	33.7	15.1	6.7	—	44.2
Texas PanH.	Gray	44.5	0.8040	30	0.42	44.7	—	15.8	—	39.4
Texas West	Pecos	21.0	0.9279	-2.5	2.12	13.1	—	19.3	—	67.6
California	San Joachim	27.2	0.8916	—	0.49	26.1	—	50.5	—	23.4
California	San Joachim	13.5	0.9759	—	0.79	3.9	—	38.1	—	58.0
California	Kettleman	50.2	0.7788	—	0.14	73.9	—	—	—	26.1
California	Newhall	29.4	0.8794	—	0.27	31.7	—	—	—	33.2
California	LA—Long Beads	26.4	0.8961	—	1.13	26.9	—	31.7	—	41.4
Louisiana	Calcasieu	41.5	0.8179	<5	0.10	34.2*	13.2	24.8	14.4	9.3
Louisiana	Terrebonne	17.1	0.9522	—	0.53	—	—	22.9	35.8	38.2
Louisiana	Refugio *	2.40	0.9100	—	0.14	—	—	55.5	30.5	12.7
Canada	Fort Norman	35.8	0.846	<5	0.33	33.4	11.6	14.5	18.4	21.3
Canada	Petrolia	33.2	0.859	<5	0.72	22.2	16.1	7.5	19.1	34.9
Mexico	Los NaranjoB	21.1	0.9270	<5	3.67	11.9	12.0	2.00	12.6	40.0
Mexico	Pozarica	30.6	0.8370	—	1.81	20.6	9.6	6.3	—	62.0
<i>South America.</i>										
Venezuela	Lagunillas	17.4	0.9500	—	2.2	5.7	—	14.7	—	79.6
Venezuela	El Mene	37.0	0.8400	—	0.2	40.0	—	29.0	—	31.0
Argentina	Comodoro * > / Ulvadavia /	28.9	0.8820	45	0.13	10.8	12.5	14.4	—	62.3
Argentina	Mendoza	30.8	0.8720	55	0.19	29.4	—	15.8	23.1	31.7
Colombia		4.20	0.8155	<50	0.16	52.0	—	22.0	—	5.0
Peru		37.2	0.8388	—	0.10	37.7	—	—	—	61.8
Ecuador		4.2	0.8193	<0	0.05	40.2	15.0	—	—	44.7
<i>Dutch East Indies.</i>										
Sumatra	Pladjoe	45.4	0.8000	—	—	55.0	15.0	9.0	—	19.5
Sumatra	Pladjoe	25.7	0.8000	+25	—	7.0	6.0	4.0	—	81.5
Java	Wonokromo	22.3	0.8200	+25	—	17.5	—	50.5	—	30.5
Borneo	Balikpapan	33.6	0.8370	+25	—	35.0	29.0	15.5	—	19.0
<i>Miscellaneous.</i>										
Japan	Nishiyama	44.3	0.8050	—	0.20	36.2	30.7	7.5	24.8	—
Japan	Nishiyama	27.5	0.8900	—	0.24	15.0	29.3	14.4	39.8	—
Burma		37.0	0.8400	80	0.15	18.4	32.4	42.2	—	6.4
Iran		37.8	0.8360	—	1.0	33.5	23.0	—	—	43.5
Bahrein		31.9	0.8660	^ 0	2.0	29.6	17.4*	—	—	59.1
Iraq		36.2	0.8440	^ > 0	2.0	18.5	79.5	17.5	—	44.5
Egypt		25.7	0.9000	^ 30	2.8	12.5	7.5	16.0	—	64.0
U.S.S.R.	Balakhany	3.00	0.8762	<20° G	0.10	4.8	27.5	7.3	—	60.0
U.S.S.R.	Bibi-Eibat	26.0	0.9000	<70	0.17	2.9	27.5	8.6	—	60.8
U.S.S.R.	Dossor	28.5	0.8844	<100	0.15	0.50	17.0	16.0	—	66.5
Rumania	Moreni	26.0	0.9000	—	—	22.7	8.4	4.3	—	64.6
Rumania	Itasvad	35.4	0.8480	—	—	26.1	10.8	16.8	—	46.8
Poland	Potok	40.6	0.8220	0	—	44.2	16.8	9.0	21.0	8.0

\* Naphtha, includes 7.5% gasoline, based on crude,  
 † Kerosene and lubricating oil not reported,  
 ‡ Includes 61% of gasoline, based on crude.

of gasoline is noteworthy since this is about twice as much as was produced twenty years earlier. The gasoline figure includes that produced by primary straight-run distillation and that produced by cracking and auxiliary processes. It does not include aviation fuel. The

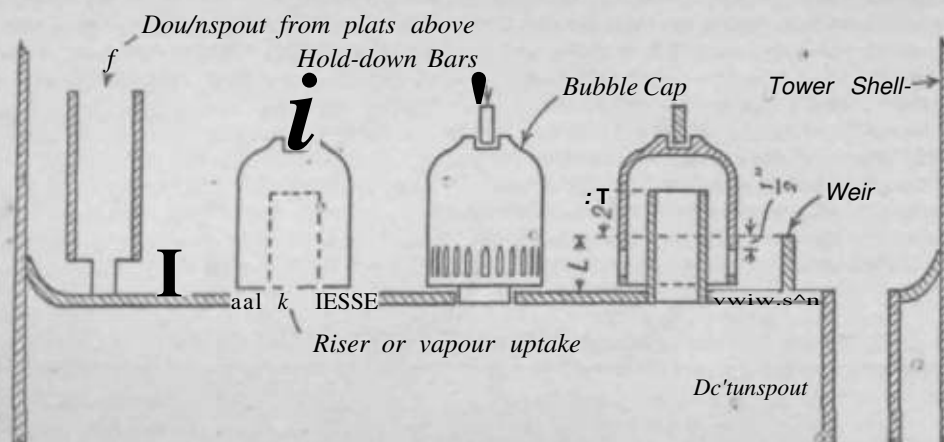

FIG. 10.

1945 figures for gasoline production cannot be properly evaluated on account of the transition from war to peace in that year.

TABLE VI.—Production of Petroleum Products in the U.S., 1944.

		Thousands of barrels.	Vol. %.
Crude run to stills	—	1,605,084	100
Motor fuel	—	744,075	44.7
Kerosene	—	78,344	4.7
Distillate fuel oil	—	239,152	14.3
Industrial fuel oil	—	401,455	27.7
Lubricating oil	—	41,100	2.5
Wax (thousands of pounds)	807,240	—	—
Coke (short tons)	1,803,400	—	—
Asphalt (short tons)	6,000,100	—	—
Road oil	—	1,550	0.1
Still gas (millions of cu. ft.)	308,001	—	—

#### CRACKING.

The term "cracking" is applied to processes in which hydrocarbon or other oils are decomposed at elevated temperatures to produce gasoline. When cracking petroleum fractions heavier than gasoline, such as kerosene, gas oil, or residues, moderate temperature conditions corresponding to lesser decomposition produce more liquid products, while high temperatures produce larger amounts of gas. Nearly all cracking is attended with the production of varying amounts of carbonaceous material which may be heavy liquid or semi-solid residues, or coke.<sup>38</sup>

The decomposition of animal and vegetable oils by heat was practised on a small scale prior to the inauguration of the petroleum industry as such. Benzene, for example, was discovered by Faraday in 1825 in the products of the thermal decomposition of fish and vegetable oils. The discovery in 1801 that petroleum oils could be cracked into lower-boiling products is supposed to have been accidental. A stillman is said to have lowered his fires to retard a distillation

during his absence, so that some of the outgoing still vapours condensed and fell back into the hot oil in the still. Upon his return he was surprised to find that the specific gravity of the condensate from his still was lower than when he left it. Cracking of heavy hydrocarbons was recognised by Peckham in 1869,<sup>38</sup> who reported that 28.6% of illuminating oil could be obtained by distillation of heavy oils under pressures of from 30 to 40 psi.\* Cracking was first employed to increase the yields of illuminating oil from crude petroleum, as that was the primary product desired for many years. Pressures employed were moderate and seldom over 100 psi., although in 1904 Ipatieff used pressures up to 6,000 psi. in experimental work."

#### Thermal Cracking.

Prior to the commercialisation of cracking for the production of gasoline in 1913, a number of processes proposed distilling oils at pressures as high as 500 psi. and temperatures above 538°C. (1,000°F.). Some of these processes specified the use of pipe coils for heating the oil, and the use of steam mixed with oil vapours during their passage through the coils. Others specified the use of heated pipe coils with succeeding chambers for the separation and collection of heavy products; the vapours and gases passing into condensing equipment for the recovery of low boiling liquids.

The advent of the automobile made increased yields of gasoline from petroleum imperative and led to the first commercialisation of the cracking process to produce gasoline by Dr. W. M. Burton of Standard Oil Company of Indiana in 1913. Gas-oil distillates were charged to horizontal stills 8 ft. in diameter and 30 ft. long. The still contents were heated at 400°C. (750°F.), first at 75 and later at 95 psi. to effect a slow distillation. Long air-cooled vapour lines condensed a portion of the distilled vapours so that they refluxed back into the still. Pressure was maintained through the condenser and

\* Pound per square inch pressure.

receiver and 30-35% by volume of gasoline was obtained.

The developments in cracking since 1913 have been along the lines of higher temperatures and pressures and better design of equipment to permit better heating, greater throughputs, higher production of gasoline, the use of heavier coke-forming residual oils as charging stocks and the recycle of distillate fractions free from process residues (clean circulation). One of the first developments was the use of apparatus resembling a water tube boiler, the unvaporised portions from the heated tubes circulating back to the tubes by a thermosiphonic effect. With more heating surface and greater speed of flow of the oil through the tubes, carbon was kept from depositing and operating periods were longer. In later developments of this type of apparatus the reirculated oil was forced through the tube by interior pumps and the liquid levels were maintained by introducing fresh oil to make the process semi-continuous until coke deposits necessitated a shut-down.

Succeeding developments have been concerned with the use of higher pressures up to 1,000 psi., and, the use of better fractionating equipment to separate gases, gasoline, and intermediate boiling-range recycle-stocks having low carbon-forming tendencies, heavy residual oils being withdrawn without further cracking. In another development crude oil charge is introduced into the cracking plant fractionator.

Both horizontal and vertical reaction chambers have been used in which liquid and vapour separate, and in which high or low liquid level are maintained, or coke allowed to deposit.

Figs. 11-19 inclusive show in outline some of the steps in the development of present-day commercial cracking plants. Design B have

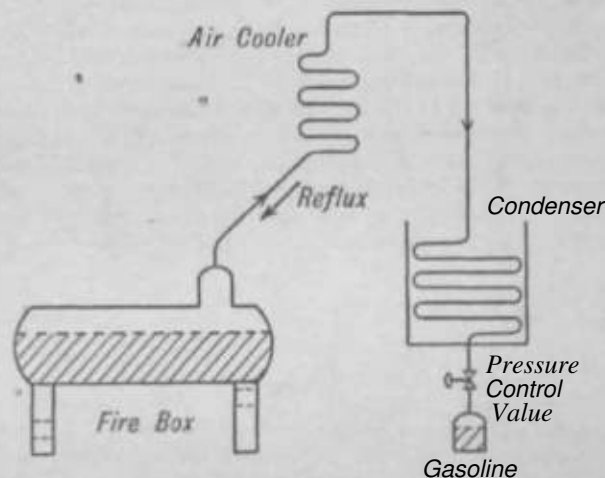

Fig. 11.

undergone a wide variety of modifications. A complete and detailed description of the many types of cracking plants that have been constructed would be unwarranted and only the more important developments will be described.

Fig. 11 shows a simple pressure-shell still arrangement as in the Burton Process. The still

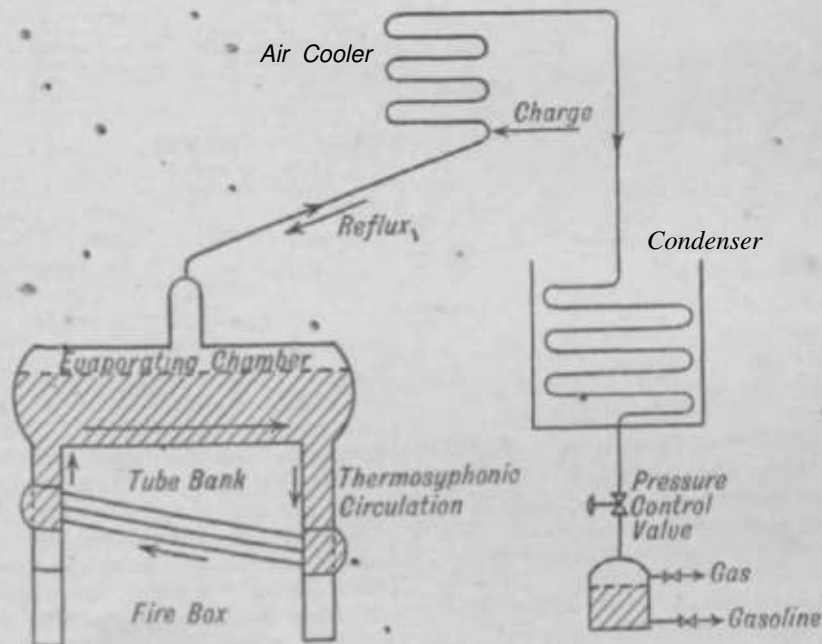

Fig. 11f

was charged with a definite amount of oil which was distilled under pressure, while a portion of the evolved vapours were condensed in an air cooler to flow back to the still. Such stills were charged with 200-250 barrels of gas oil and about 24 hours were required for a distillation, which yielded 30-35% of motor fuel. Carbon

deposits were scraped from the bottom of the still after the liquid residue was drawn off.

Fig. 12 shows a somewhat later development with two added features (Burton-Clark Process). One is the construction of the still to resemble a water tube boiler with a heated tube bank and an insulated horizontal cylindrical vessel. The

furnace heat was applied to the sloping tubes so that circulation of the oil took place by convection and the lighter products of decomposition were evaporated in the enlarged portion of the still. Better heat transfer was accomplished in this apparatus, and the flow of oil through the tubes kept part of the carbon washed from the heated surfaces. The level of the oil in the evaporating chamber was maintained at a fixed point by the continuous admission of gas oil into the reflux line until the character of the residual oil in the still became so heavy that carbon formation was excessive, at which time operations were discontinued and the plant cleaned out. This arrangement of apparatus also employed air cooling for obtaining reflux and maintained pressure through the condenser.

Further improvements consisted in increasing the period of operation by aiding the circulation of the oil through the heated tube bank by mechanical means, feeding charge oil to the still and withdrawing continuously from the still some fuel oil residue, as in the Trumble process.

Fig. 13 shows a specific application of this principle in the Jenkins stills.

In addition to the thermally induced circulation through the heated tube bank, an impeller created more rapid circulation through the tubes and further lessened the tendency for carbon to deposit. The charge was introduced to a primary fractionator wherein it served as a refluxing medium and wherein lighter portions were distilled off, the heavy fractions flowing into the evaporating chamber. Fuel oil residuum was

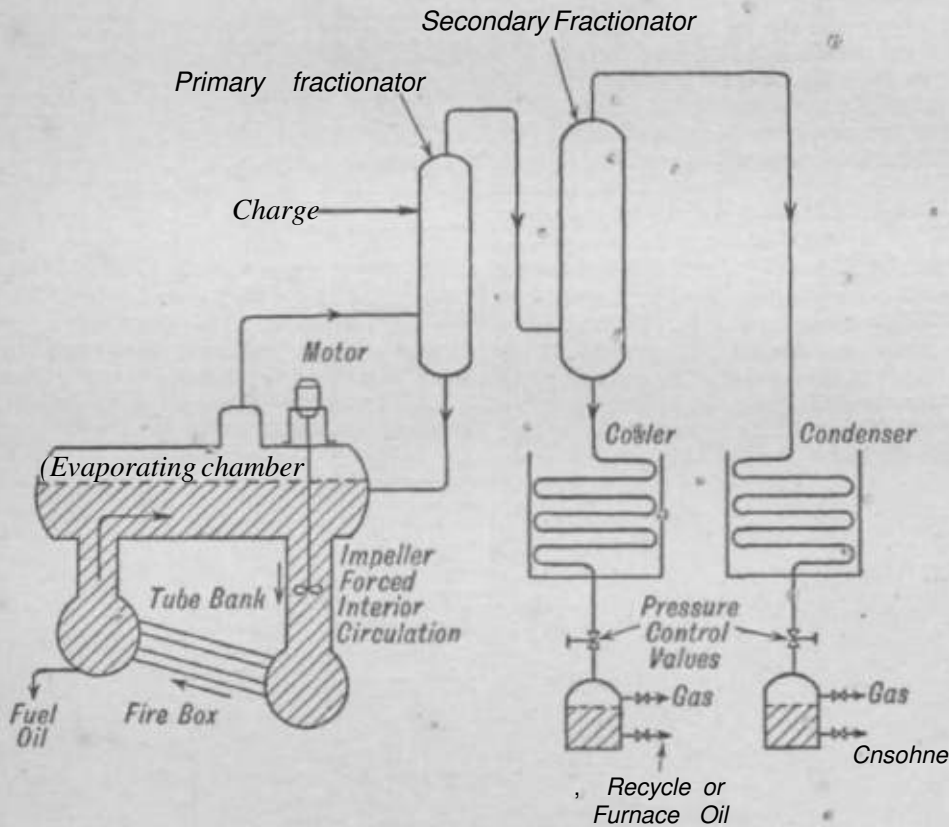

FIG. 13.

drawn continuously from the system so that the operation was essentially continuous. A secondary fractionator separated the vapours from the primary column into gasoline and recycle stock for further cracking treatment or sale as furnace oil.

Fig. 14 shows a cracking plant with multiple reaction chambers in which both the pipe still and chambers are heated to a high level of liquid is maintained in the chambers. The charging oil is passed through a coil in a small chamber at the top of a fractionator to absorb heat and produce reflux for the fractionator, the charge then passing through the upper section of a pipe still to become further preheated. A pump takes fractionator bottoms and a portion of the residual liquid from the third and fourth reaction chambers in the series and forces the

mixture through the lower section of the pipe still and then into the bottom of the first two of the reaction chambers. The chambers are interconnected by equalising lines so that liquid and vapours have free passage between them. Each chamber is provided with a rotating scraper with arms for removing carbon deposits from its walls. Gasoline is obtained both from the vapours and the residual liquid from the reaction chambers.

In the plants described in Figs. 12-14 inclusive, the partially cracked oils returned for further cracking all contain a certain amount of residual material which has relatively high coke forming properties. This operation is currently known as "dirty circulation."

In the Dubbs process of Universal Oil Products Company several advances were made in the



cracking art, particularly in handling heavy residual charging-oils. The use of "clean circulation" was a novel feature. In this type of operation only partially cracked vaporised intermediate boiling-range products were recycled for further cracking, and all residual cracked products were removed so that carbon deposits in

heated cracking tubes were minimised. Fig. 15 shows the flow in a process of this character. The charge was introduced to a dephlegmator and fractionated along with cracked products from the reaction chamber, a portion of the charge being fed directly if desired. The liquid products from the dephlegmator flowed by gravity into

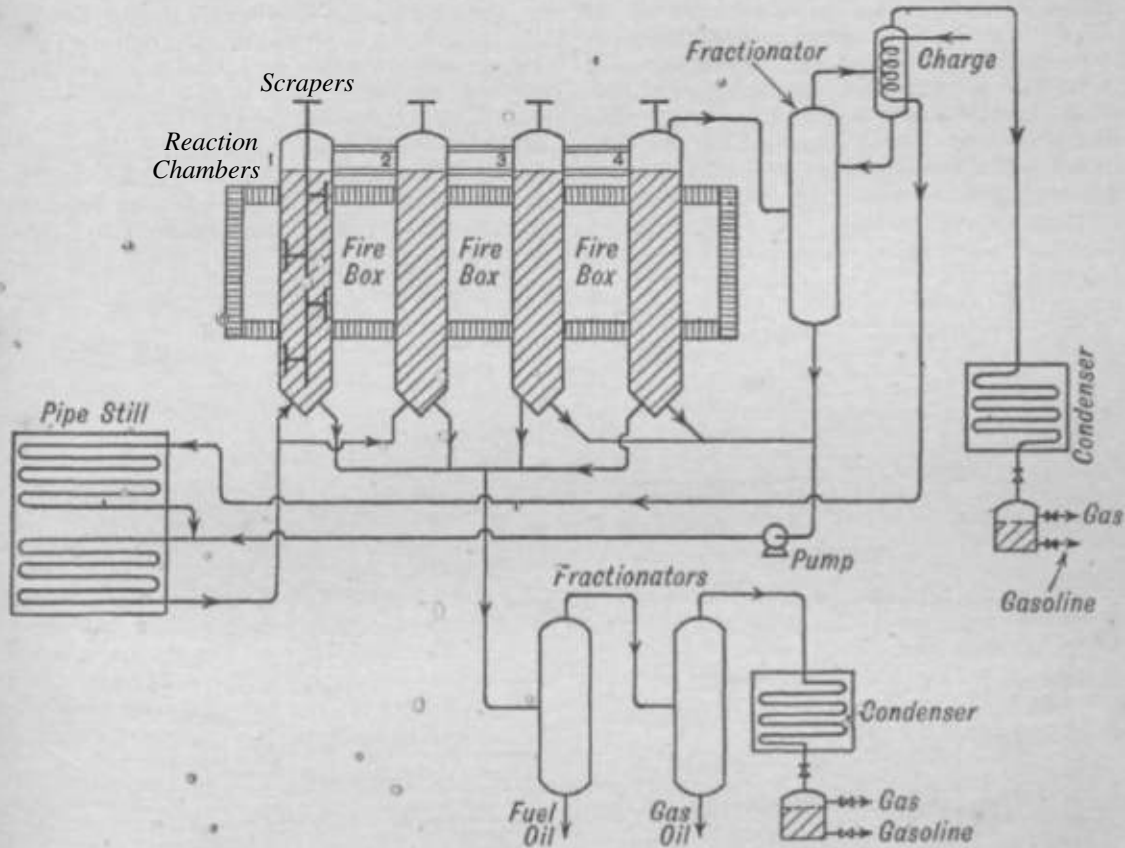

FIG. 14.

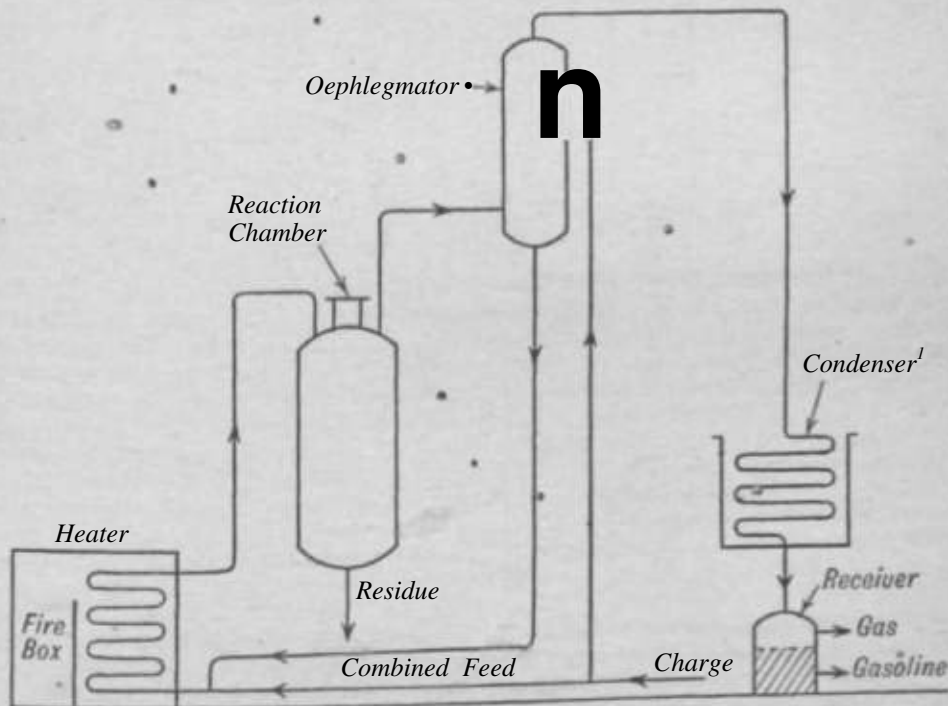

FIG. 15.



the heated cracking tubes along with such portions of the charge as were admitted directly. The heated products from the cracking tubes entered & reaction chamber which provided time for the completion of the cracking reactions and

effected a separation of vaporous and liquid products, the former passing to the dephlegmator for fractionation into a mixture of gas, gasoline vapours and recycle stock, and the last being withdrawn as residue. By extending the time

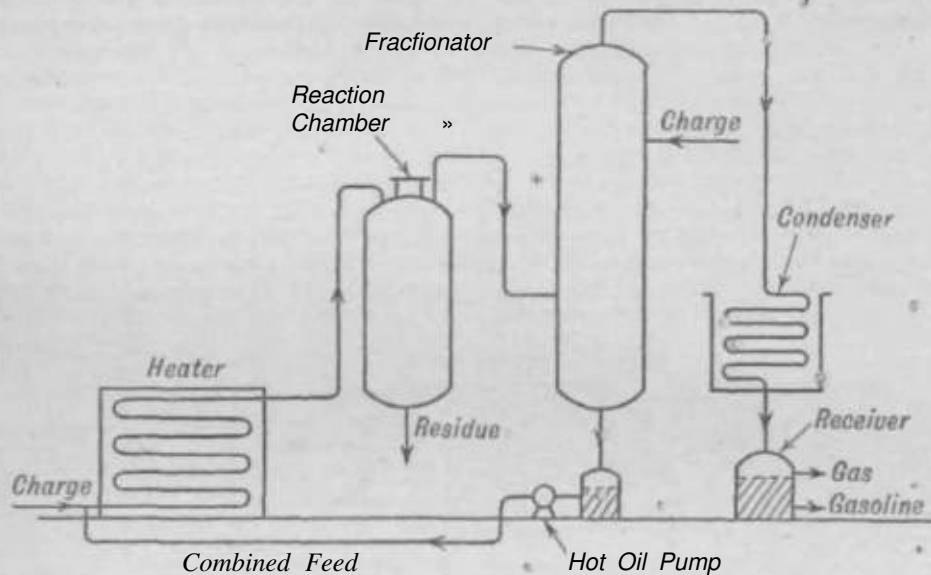

Fig. 16.

of cracking in the reaction chamber, coke was deposited and allowed to build up, the coke being removed periodically while the cracked products from the heated tubes were diverted into a parallel chamber to ensure the continuity of the process.

Fig. 16 allows the flow in a succeeding development of the Universal Oil Products Company process, the added feature being the use of a hot oil pump for increasing the rate of combined feed to the cracking tubes. By this means, recycle of intermediate boiling-range products for further

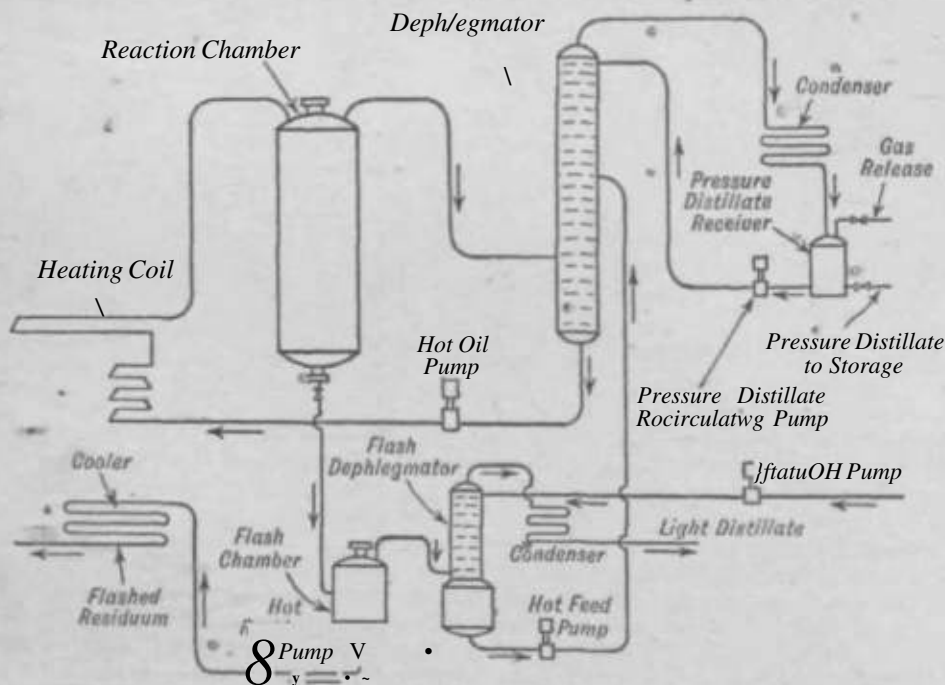

Fig. 17.

cracking was increased and an added control of the extent and character of cracking was provided. As before, either liquid residue or coke was produced in the reaction chamber according to the intensity of cracking. The fractionator

was larger and installed at a lower level, since its elevation was not necessary.

In a further development stage, the residuum from the reaction chamber was passed to a reduced-pressure flash chamber from which light

distillate<sup>1</sup> vapours were evolved and a residuum was pumped. The flow of this process is shown in Fig. 17. The vapours from the flash chamber are passed to a dephlegmator for further fractionation into a light distillate or naphtha, and an intermediate boiling-range liquid which was pumped to the main dephlegmator to form part of the combined feed going to the cracking tubes. In this way a larger amount of intermediate boiling-range recycle stocks was produced and the yield of cracked gasoline was increased.

A still later commercial development of the Universal Oil Products Company process is shown in Fig. 18. In this plant the new features include the use of separate heating elements for cracking light and heavy stocks which are withdrawn from different levels in the fractionating column, these stocks include both components

of the charging oil and of the cracked products. Another feature is the use of separate coke chambers into which the total products from the reaction chamber are admitted to form coke and vapours, which then enter the flash chamber and subsequently the final fractionating column into which the charge is admitted. A crude oil from which straight-run gasoline has been removed is introduced to the lowest section of a fractionating column in which it undergoes fractionation along with vaporous products from cracking. An intermediate\* boiling-range reflux is withdrawn from a collecting plate above the point of admission of the charge, pumped through a light oil heater and into an enlarged chamber, while the bottom liquid from the fractionating column is pumped through a separate heavy oil heater into the same chamber. Conditions of tempera-

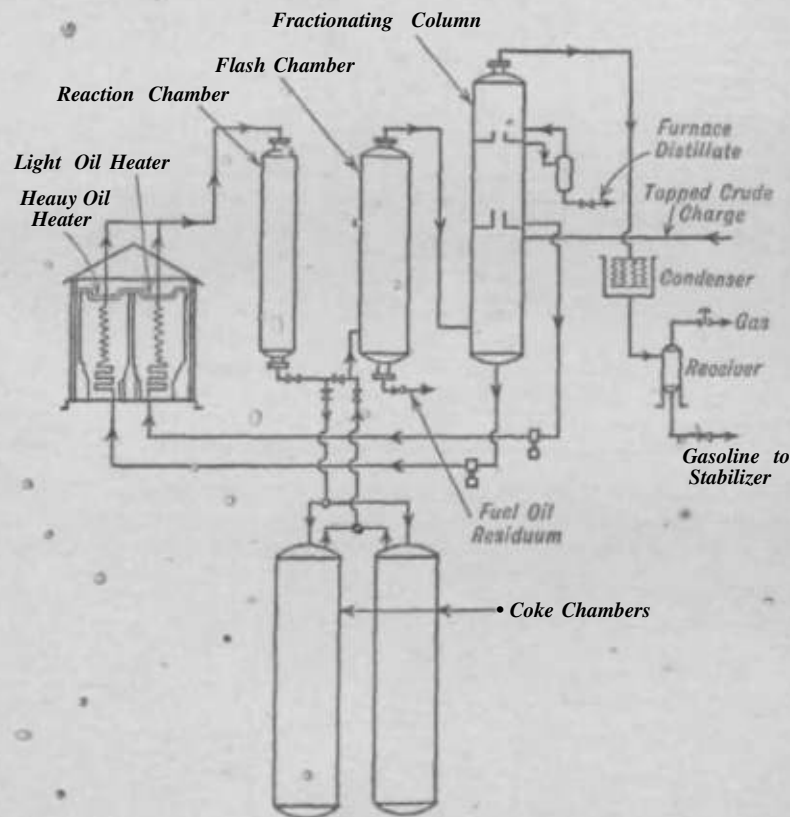

Fig. 18.

Temperature and pressure are varied in each heater so that combinations most suitable for the thermal conversion of each oil stream are maintained, and the heated products from both cracking elements pass together into the reaction chamber and then into the insulated coking chambers wherein coke gradually builds up. Cracked vapours pass to a chamber in which a rough separation is made of a fuel oil residuum and hydrocarbon vapours containing cracked gasoline. In this drawing, the designation "Flash chamber" is used, although this is only true when the products from the reaction chamber pass directly from the reaction chamber and by-pass the coke chambers. This type of cracking plant permits the conversion of either topped crude or crude oils themselves into coke, fuel oil, and maximum yields of cracked gasoline.

Typical data are shown in Table IX on the cracking of gas oils, fuel oil, and reduced crudes in plants arranged in general accordance with the flow shown in Fig. 18. For purposes of comparison, data are included from cracking for liquid residuum and cracking for coke using a gas-oil and a residual fuel-oil charge. Cracking the gas oil for coke gave a 72-8% (by volume) yield of gasoline compared with 68-2% when cracking for liquid residuum, the octane numbers of the gasolines being approximately the same, although the end boiling-point of the gasoline from the coking run is higher than from the residuum run. Similar comparisons were found between the two types of cracking in the case of the fuel oil, a yield of gasoline of 67-2% when coking, and 51-3% when cracking for residuum being obtained. In this pair of runs

TABLE IX.—CRACKING FOB GASOLINE AND CORK.

Type of cracking	2 Coil Residuum. Gas oil.	2 (oil QM CSL	2 Cull residuum. Fuel oil.	2 foil cokin)!. Fuel oil.	i Coll Coking. Keduced crude.	1 foil cuking. ltodiced crude.
Stock cracked.						
Sp.gr.	0-8670			0-9042		0-9235
X.V.I. «r.	31-7			25-0		20-9
Initial b.j>.	"O. °F.			"O. °F.		"C. *y.
10%	200 392			101 375		267 513
60%	203 660			208 568		311 592
90%	351 653			381 717		374 706
End b.pr	398 744			398 744		401 753
	404 760 +			396 744 +		401 763
Operating Conditions;	"O. °F.	"C. °F.	"O. °F.	"O. °F.	"C. °F.	"O. °F.
Transfer temp., heavy oil heater	493 020	943 <J-M	488 flO	488 910	477 890	477 890
.. .. light .. "	518 960	516 060	510 050	610 950		
Reaction chamber temp. . .	477 890	*77 890	471 880	471 880	449 840	440 840
.. .. ii m press., pal.	250	250	200	200	200	15
Products:						
Gasoline, vol. % . . . . .	08-2	72-8	514	er-2	49'4	291
Gas oil, vol. % . . . . .					27-7	54-4
Residuum, vol. % . . . . .	19-4		41 -3		i -	
Coke, lta. per barrel . . . . .		10-8		BS-8	71-5	530
Gas, cu. ft. per barrel . . . . .	635	820	479	840	550	437
Properties of gasoline :						
8	0-7316	0-7420	0-7347	5-7882	0-7407	0-7475
A.P.I. gr . . . . .	61-9	59-2	61-1	00-7	58-0	C7-8
Initial b.ji	*C °F.	*O. °F.	*C °F.	*O. °F.	"C. °F.	"O. °F.
10%	37 98	34 JH	32 90	37 90	37 98	41 106
50%	60 140	G'Z 144	SI 142	05 149	09 156	75 167
90%	118 245	125 257	VJa 164	122 252	137 276	140 284
00%	187 388	202 396	168 370	130 372	193 380	188 370
Knd b.p	2<5 401	232 450	207 405	207 404	212 414	204 4(H>
Octane No., A.S.T.M..	68	07	66	67	81	61
Properties of residuum:						
Sp.gr	10583		1-0107			
A.P.I. er.	2-2		8-5			
Coke, fixed carbon. . . . .	— 91	-2i-		0210	01.82	83-23

tho gasolines were of the same end boiling-point, and that from the taking run had a higher specific gravity and a slightly higher octane rating.

Fig. 19 shows the flow in a Universal Oil Products Company type of cracking plant designed for making maximum amounts of gasoline and liquid fuel without cokjng. In this operation

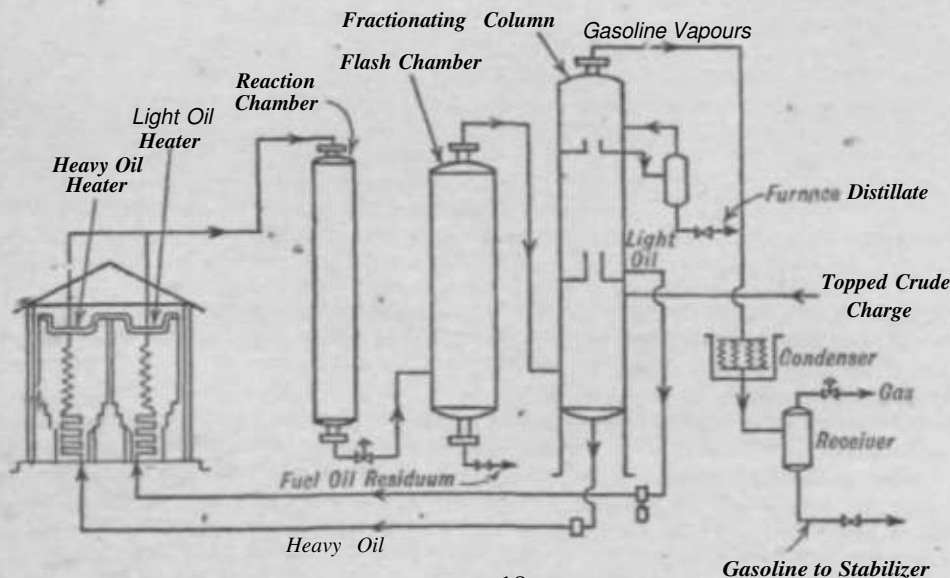

FIG. 19.

the severity of cracking conditions is regulated BO that commercial grades of fuel oil are produced and long runs are mad© between times of shut-downs for cleaning. This operation also produces furnace distillate.

Typical operating conditions and yields of products from cracking in plants similar to that Bhowm in Fig. 19 are given in Table X.<sup>41</sup> The data include those from cracking runs on kerosene, gas oil, reduced crude, fuel oil, and

TABLE X.—GBAOKINO FOB QASOLINB AND LIQUID RESIDUE.

Type of cracking	ICoil. Kerosen.		ICoil. Reduced crude.		2 Coil. Fuel oil.		2 Coil. Gas oil.		2 Coil. Topped crude.		2 Coil. Crude.		ICoil. Topped crude.		
Stock cracked	0-8478 35*4		0-8849 28*4		0-9030 25-2		0*8838 28-6		0*9279 200		0*9076 24*4		0*8586 33-3		
Initial b.p.	173	344	191	375	232	450	228	442	225	437	187	368	252	486	
10% over	201	394	274	526	322	612	277	530	263	596	229	444	277	530	
50% over	267	513	378	712	362	684	348	658	357	675	289	552	326	618	
90% over	332	629	—	—	399	750	399	750	Cracking	393	740	393	740	393	740
End b.p.	370	698	—	—	373	704	402	759	386	726	396	744	399	750	
Operating conditions:	°C. °F.		°C. °F.		°C. °F.		°C. °F.		°C. °F.		°C. °F.		°C. °F.		
Transfer temperature	510	950	510	950	449	915	502	935	493	920	510	950	504	940	
Reaction chamber temp.	482	900	482	900	468	875	477	890	466	870	482	900	477	890	
Reaction chamber pressure, psi.	350	350	H200	300	L400	300	200	250	250	300	255				
Products:	%		%		%		%		%		%		%		
Gasoline, vol. %	70*	600	550	590	480	490	640								
Residuum, vol. % <sup>^</sup>	14*	30*	350	260	450	29-5	200								
* Gas, cu. ft. per barrel	650	575	525	750	401	983	802								
Properties of gasoline:	0 -7628 54°		0-7408 59*		0*7332 61-5		0-7428 590		0-7507 570		0*7711 520		0*7286 627		
A <sup>^</sup> .gr. ; : : ;	°C. °F.		°C. °F.		°C. °F.		°C. °F.		°C. °F.		°C. °F.		°C. °F.		
Initial b.p.	32	90	32	90	35	95	41	105	38	100	36	97	36	97	
10% over	66	150	63	145	>54	130	62	144	63	145	60	140	59	138	
50% over	138	280	132	270	113	235	118	245	129	264	121	250	103	217	
90% over	177	350	190	385	177	350	176	348	181	357	178	353	162	323	
End b.p.	193	380	204	400	204,	400	208	406	202	396	208	407	209	409	
Octane No., A.S.T.M.	90*	73*	70	72	71	79	70								
Properties of residuum:	1*0291 60		1*0143 80		10143 80		10631 1-6		10143 80		1*0752 01		1*5066 50		

H Heavy oil coil.

L Light oil coil.

\* Research method.

topped crudes, and also one run, on a whole crude. The highest yields of gasoline were obtained from the kerosene, and the lowest from the first of the topped crudes. The octane numbers of all gasolines were 70 or higher by the A.S.T.M. method, except from the reduced crude run in the second column of Table X. In this case the earlier research method of determining octane number gave a value of 73, which would correspond to a figure below 70 by the A.S.T.M. method.

*Viscosity Breaking.*

Viscous crude oils and residua are sometimes mildly cracked to produce fuel oils of lower viscosities which conform to standard specifications in this respect, such as the A.S.T.M. No. 6 fuel oil, which must have less than 300 seconds Saybolt furol viscosity at 50°c. (122°F.). Such operations are known as viscosity breaking and are carried out under relatively low temperatures from about 416°o. (780°F.) to 480°c. (896°p.). Pressures may vary from about 100 to 500 psi., and sufficient cracking is brought about in a single passage through the cracking coil without recycling. The thinning of the oils by this process is due principally to the breakdown of the heavier components into intermediate products of the character of gas oils, although small amounts of gasoline are formed, usually P-^ % by volume of the charge. The gasoline is distilled and recovered and the intermediate products are used directly as light fuel-oils,

cracking stocks for gasoline manufacture, or diluents for the residuum from the cracking to bring the viscosity below maximum limit requirements.

A typical group of viscosity-breaking runs is summarised by the data in Table XI.<sup>48</sup> A topped crude oil from an Illinois field was cracked in a once-through operation to find the best conditions for producing a minimum yield of 300 second Saybolt furol viscosity residuum, and maximum yields of distillate fuel oils. The topped crude oil was cracked in a heated tubular element and a reaction chamber under the conditions shown in the Table, and the products were distilled to produce gas, gasoline, light and heavy distillates, and residuum. The total distillate products were designated as synthetic crude.

The yield of gasoline and gas varied from 61 % by weight in Run 3 to 13\*2% by weight in Run 6, while the residuum yield was a minimum of 37\*7% in Run 4, and a maximum of 41 -3% in Run 5. Since the object of the runs was to produce a fuel oil residuum having a viscosity of less than 300 seconds, all runs met this requirement except Run 4. The yield of light and heavy distillates was highest in Run 1. The octane numbers of the gasoline ranged from 64\*6 in Run 1 to 67\*7 in Run 6.

Another example of viscosity breaking is given in Table XII, which shows the results in cracking a viscous crude oil at 415°c. (779°F.) at 150 psi. for a time of about 13 minutes under these cracking conditions.<sup>44</sup>

TABLE XI.—VISCOSITY BREAKING.

Run number	1	2	3	4	5	6
<b>Operating conditions:</b>						
Temperature, °C.	459	471	449	477	449	471
Temperature, °F.	859	880	480	891	840	880
Pressure, psi.	100	100	100	100	200	200
<b>Yields, vol.-% charge:</b>						
Synthetic crude.	63.9	63.2	62.0	63.8	61.1	63.1
Residuum.	36.4	36.3	38.6	35.3	39.0	36.6
<b>Yields, wt.-% charge:</b>						
Gasoline and gas.	8.0	10.4	6.1	11.3	8.9	13.2
No. 2 distillate.	25.5	24.1	21.9	22.9	21.6	23.0
Heavy distillate.	27.8	27.0	31.3	28.1	30.8	24.9
Residuum.	38.7	38.5	40.7	37.7	41.3	38.9
<b>PROPERTIES OF PRODUCTS.</b>						
<b>Synthetic crude:</b>						
Sp. gr.	0.8560	0.8524	0.8591	0.8509	0.8007	0.8488
Viscosity, Saybolt univ. at 38°C. (100°F.).	33.8	34.5	33.2	34.8	32.9	35.2
<b>Gasoline:</b>						
Sp. gr.	0.7499	0.7275	0.7301	0.7351	0.7290	0.7313
A.P.I. gr.	57.2	63.0	66.3	61.0	62.6	62.0
Octane number.	64.6	67.1	65.7	66.2	67.4	67.7
<b>No. 2 Distillate:</b>						
Sp. gr.	0.8524	0.8524	0.8509	0.8468	0.8504	0.8540
A.P.I. gr.	34.5	34.5	34.8	35.6	34.9	34.2
<b>Heavy distillate:</b>						
Sp. gr.	0.8950	0.8984	0.8905	0.8996	0.8927	0.8996
Viscosity, Saybolt univ. at 50°C. (122°F.).	26.6	26.0	27.4	25.8	27.0	25.8
Sp. gr.	0.8950	0.8984	0.8905	0.8996	0.8927	0.8996
Viscosity, Saybolt univ. at 50°C. (122°F.).	98.3 sec.	91.0	88.0	121.0*	135.0*	86.5
<b>Residuum:</b>						
Sp. gr.	0.9685	0.9725	0.9032	0.9752	0.9665	0.9732
A.P.I. gr.	14.6	14.0	15.4	13.6	14.9	13.9
Viscosity, Saybolt univ. at 50°C. (122°F.).	260 sec.	260	250	302	237	260

\* At 38°C. (100°F.).

TABLE XII.—VISCOSITY BREAKING OF CBUDB OIL.

Charge and product.	Crude oil, specific gravity.	Viscosity, Saybolt at 50°c. (122°F.).	flash point.		Gas and loss.
			°C.	°F.	
Crude	0.955	905 sec.	136	277	0
Cracked crude	0.946	219 sec.	64	147	20

*Vapour-phase Cracking.*

In addition to the types of processes described, which are aimed at the production of maximum yields of gasoline and which operate so that mixed liquid-vapour-phase conditions obtain in the cracking zone, another type of process operates essentially in the vapour phase at high temperatures and atmospheric or slightly super-atmospheric pressures. Such operations necessarily involve the use of larger equipment and tend to produce greater amounts of aromatic hydrocarbons and gaseous products. Commercial plants employ highly-heated tubular elements and very large reaction chambers. Some commercial vapour-phase processes utilise diluent gases such as steam or hydrogen so that in effect operations are conducted at subatmospheric pressures in respect to the oil vapours. In such processes, the recovery of gasoline from

the cracked vapours requires\* the use of absorption oils or cooling and compression.

The temperatures employed in vapour-phase cracking are from 550° to 650°c. (1,022° to 1,202°F.), and the pressures vary from atmospheric to 5 atm. (75 psi.). Under the high temperatures employed, heat transfer is satisfactory even at the low pressure\* used. Although temperatures up to 800°c. (1,472°F.) may be employed in vapour-phase cracking, the use of those above 650°c. (1,202°F.) is impractical, due to hard coke formation and rapid deterioration of tubes. The use of the higher temperatures mentioned results mainly in the production of aromatic hydrocarbons. Only comparatively light distillates such as naphthas, kerosene, and light gas oil can be cracked in the vapour phase, since heavy distillates and residual oils form excessive amounts of coke which soon cause overheating and clogging of tubes.

Table XIII shows some results on the vapour-phase cracking on a light naphtha having a specific gravity of 0.835 (38° A.P.I.), and a boiling range of 136-185°c. (277-365°F.).<sup>45</sup> The data show that the formation of gasoline passed through a maximum at 650-700°c. (1,202-1,292°F.), and that the amount of residuum decreased and the amount of gas increased up to 800°c. (1,472°F.). The gas at the higher temperatures consisted largely of hydrogen and methane.

TABLE XIII.—VAFOITH-PHASB CHACSING OF NAPHTHA AT ATMOSPHERIC PRESSURE.

Yields % by weight.

Temperature . . . . .	°C. °F.	°C. °F.	°C. °F.	°C. °F.	°C. °F.	°C. °F.
	GOO 1,112	850 1,202	700 1,212	750 1,382	800 1,472	850 1,502
Gasoline . . . . .	170	24.5	240	19.5	200	170
Residuum . . . . .	68.8	30.3	22.8	21.7	220	191
Gae . . . . .	14.2	45.2	62.2	58.5	680	52.9

*Tkernud Reforming.*

In addition to cracking portions of crude petroleums heavier than gasoline, low octane number straight-run gasolines are cracked or "reformed" to improve their knock ratings. In such operations conditions are chosen so that there is a maximim production of hydrocarbon molecules of altered structure and higher anti-knock value, and minimum production of gases and hydrocarbons heavier than gasoline. The conditions for reforming are more severe than those used in cracking heavy distillates and residual oils. In commercial practice, temperatures of 510°o. (950°F.) to 638°o. (1,000°F.) or higher and pressures of around 750 psi. are employed. Yields of reformed gasoline range from 65 to 90% inversely as tho octane rating increases.

A typical process flow in a reforming plant is shown in Fig. 20. A gasoline of low knock rating is pumped through a pipe coil comprising a heated section and an unheated "soaking" section, after which cooler oil in injected to reduce the temperature quickly, and arrest the cracking reactions short of undue formation of gases and heavy products. The reformed products and quench oil are fractionated into gases, gasoline, and heavier oik.

In reforming gasolines, as in cracking heavier oils, the anti-knock value of the gasolines produced is higher because of the presence of increased amounts of olefinic, aromatic, and *iso*-paraffinic hydrocarbons.

Some typical results obtained in thermal reforming of straight-run gasolines and naphthas are given in Table XIV." The data indicate

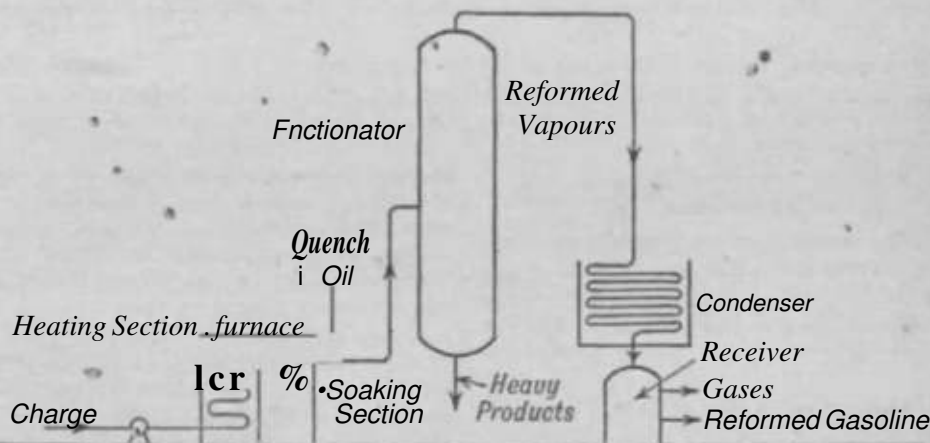

FIG. 20.

that the losses in producing reformed gasolines of around 70 octane number are definitely higher with lower octane rating gasolines typified by the PennBylvanian and Michigan stocks, which yielded about 65% of reformed product. The Texas, Montana, and Californian stocks which had octane ratings over 50 gave from 69.2 to 79.6% by volume yields of reformed products.

Thermal reforming of gasolines and naphthas for the production of low molecular weight ioifins such as ethylcno, propylene, butylenes, and pentylenos is a profitable operation when these products are needed in producing alkylates and other synthetic products. Yields of butylenes as high as 10% by liquid volume of naphthas can be produced by using temperatures around 650°o. (1,200°F.).

*Furnaces.*

One line of development in cracking and reforming has been marked by improvements in furnace design. Studies of tho location of carbon deposits along the line of flow in tubular beaters indicated critical temperatures, pressure, and flow rates at points corresponding to heavy carbon deposits. By varying heat in put-rates along the line of flow, carbon deposits were kept at a minimum by slowing np the rate of carbon formation and increasing the velocity to produce a washing aotion. The early furnaces employed convection heat alone. In later designs convection and radiant heat were separated and applied at different points in the pipe coil, certain sections being heated entirely by radiant energy from flames or heated furnace walk.



TABLE XIV.—REFORMING OF GASOLINES AND NAPHTHAS.

	Penn- sylvanian straight run gasoline.		Michigan straight run gasoline.		Midcon- tinent straight run gasoline.		Texas straight run gasoline.		Montana straight run gasoline.		Dalifornlan light naphtha.		Mexican straight run gasoline.		Iraq crude tops.	
Charging stock :	0-7463		0-7324		0-7397		0-7436		0-7397		0-7945		0-7393		0-7447	
Sp.gr. . . . .	58-1		61-7		59-8		58-8		59-8		46-6		59-9		58-5	
A.P.I.gr. . . . .	38		20		42		54		51		50		41		—	
Octane number																
	*C.	*P.	*C.	*F.	*O.	*P.	*O.	*P.	*C.	*P.	*O.	*P.	*O.	*P.	*C.	*F.
Initial b.p. . . . .	67	152	67	152	46	115	37	99	52	126	151	303	49	121	51	124
10% over at . . . . .	102	215	88	190	81	177	76	168	86	186	155	311	84	184	80	176
50% over at . . . . .	138	280	137	278	136	277	128	262	100	212	160	320	136	277	141	285
90% over at . . . . .	179	354	182	360	175	347	182	360	171	340	171	340	184	363	212	416
End b.p. . . . .	202	396	198	389	105	383	208	406	194	381	184	364	206	402	263	506
Operating conditions:																
Furnace outlet . . . . .	524	975	529	985	5381,000		524	975	518	965	524	975	521	97C	524	975
Reaction chamber . . . . .	497	926	502	935	510	950	495	925	491	915	49.6	925	493	920	496	925
Pressure, psi. . . . .	600		1,000		600		750		500		750		750		500	
Products:																
Gasoline, vol. % . . . . .	66-5		65-5		74-7		760		79-5		69-2		70-9		65-9	
Sp.gr. . . . .	0-7495		0-7351		0-7424		0-7459		0-7362		0-7870		0-7377		0-7305	
A.P.I.gr. . . . .	67-3		61*0		59-1		58-2		60-7		48-3		60-3		62-2	
Octane number.	74		67		70		72		72		77		71		70	
	*O.	*P.	*O.	*F.	*O.	*P.	*O.	*P.	*O.	*P.	*C.	*P.	*O.	*P.	*O.	*P.
Initial b.p. . . . .	29	84	34	94	32	89	32	96	36	96	34	93	29	84	36	96
10% over at . . . . .	68	154	61	142	63	146	63	146	67	146	82	179	54	130	68	136
50% over at . . . . .	87	188	89	193	126	259	117	243	117	243	147	296	115	239	116	240
00% over at . . . . .	196	384	182	360	180	356	180	356	169	336	177	350	186	366	177	350
End b.p. . . . .	207	404	202	396	193	379	179	354	197	386	194	381	204	400	105	383
Besiduum, vol. % . . . . .	4-6		4-3		1-3		202		3-8		8-2		3-3		9-5	
Gas, cu. ft. per barrel . . . . .	946		789		611		3*5		778		695		730		718	

The most improved type of furnaces apply radiant heat uniformly around the circumference of the pipes, such furnaces being known as the "equiflux" type.

*Cracking Statistics.*

In 1940 the capacity of cracking plants in the United States was 2,100,000 barrels daily charge with a production of 1,104,000 barrels of cracked gasoline, representing a yield of about 53% by volume of the oil charged. The total production of cracked gasoline in the United States in 1940 was 294,365,000 barrels, and in that year it was estimated that cracking conserved 1,444,789,000 barrels of crude oil which would otherwise have been required to meet gasoline demands. From the inception of commercial cracking in 1913 through 1944, the amount of crude oil conserved by cracking is estimated to be about 20,000,000,000 barrels in the U.S.A. alone. The effect of the Second World War, with its pressing demands for aviation fuels of ever-increasing octane rating, gave great impetus to catalytic cracking and the use of all available high octane-rating hydrocarbons for use in aviation fuel blends.

*Catalytic Cracking.*

There are definite limits to the octane numbers of gasolines producible by thermal cracking. When attempts are made to produce gasolines having octane ratings over 72, the yield decreases sharply, and the gasoline contains high percentages of olefins.

The use of catalysts in cracking increases to

varying degrees the rates of decomposition of the different types of hydrocarbons present in the charging oils. Catalytic cracking and retreating processes are employed to produce gasoline low in olefins and high in isoparaffin and aromatic hydrocarbons. The octane ratings of such gasolines are about 80, and they are used in large percentages as components of aviation fuels due to their saturated and stable character and their high octane number.

In the past few years a number of catalytic cracking processes have been commercialised. The oils charged to these processes are principally petroleum distillate fractions such as gas oils. The catalysts used are composites of silica and alumina, the silica being in major proportion by weight. Such catalysts are of a refractory character so that their activity is maintained over long periods of time, during which they are alternatively used in cracking and reactivated by burning off carbonaceous deposits.

In the catalytic cracking process, as in thermal processes, the temperatures employed vary considerably, depending upon the type of oil charged and the quality desired in the cracked gasoline. In general, temperatures below 477°C. (890°F.) are not used, nor temperatures much above 524°C. (975°F.). The production of motor gasoline may vary from about 35 to 50% on a single passage through the catalytic plant, and the octane ratings of such gasolines usually vary from about 80 to 82. The pressures employed are only slightly above atmospheric in contrast to the relatively high pressures employed in thermal cracking.

The relative yields of gaseous and liquid



product, and the types of hydrocarbons of which they are composed are different from those obtained when cracking without catalysts. The gases contain higher percentages of propylene, butylene, and butane, all of which can be used to synthesise gasoline of higher octane rating by polymerisation and alkylation reactions. The gasoline contains olefins as does gasoline from purely thermal cracking, but it also contains higher percentages of paraffins and aromatics, both of the latter groups contributing to produce the higher octane ratings noted above. It has been estimated that, if the gaseous products are processed to obtain all possible gasoline and the unconverted liquid fractions from the first passage over the catalyst are subjected to further catalytic cracking, yields of gasoline up to 85% by volume of a gas-oil charging stock can be obtained. Analyses showing the proportion of the main hydrocarbon groups in gasolines from catalytic cracking are shown in Table XVI\* (p. 346).

When catalytic cracking is conducted at the

higher temperatures in the range 477-624°C. (899-975°F.), many low-boiling olefins and alkylated aromatics are found in the gasoline fractions boiling below about 200°F. (392°F.). When using lower temperatures in this range the percentage of olefins is lower and the gasoline consists of higher percentages of isoparaffins, naphthenes, and alkyl aromatic hydrocarbons.

Three broad types of catalytic cracking processes are used commercially. These are known as the "Fixed Bed Process," "The Moving Bed Process," and "The Fluid Flow Process," the names having reference to the method of using the catalyst.

*Fixed Bed Catalytic Cracking Process.*

This catalytic cracking process uses the catalyst in the form of granules or pellets in static beds through which oil vapours preheated to cracking temperature are passed until the catalyst becomes carbonised, after which it is reactivated by burning off the carbonaceous

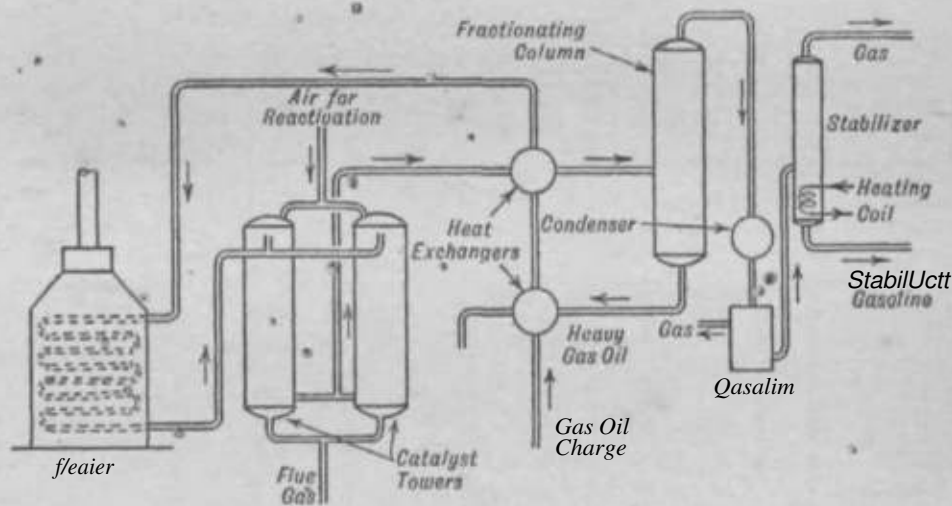

Fig. 21.

material while, the oil vapours are diverted through a bed of fresh catalyst in another reactor. Fig. 21 shows a schematic flow of this type of process, which was developed in the United States by Houdry.<sup>48</sup>

A gas-oil charge is passed in indirect heat exchange relationship with the heavy gas-oil fraction from the fractionating column and then in further heat exchange with the vapours from the catalyst towers. After heat is absorbed in these two exchange steps, the charge is passed through a heater in which the temperature is raised to a cracking level for contact with the granular catalyst in the reactors. These contain nested catalyst tubes around which molten salt mixtures are circulated to distribute heat and assist in maintaining uniform temperatures throughout the reactor. These salt mixtures are eutectics comprising mixtures of sodium nitrate and sodium nitrite. The cracked vapours pass through the heat exchanger mentioned and are then fractionated to recover gases and gasoline vapours from the top, and heavy gas oil from the bottom of the column.

The gasoline vapours are cooled and condensed and then passed to a final stabiliser from which a certain percentage of dissolved gases is removed and gasoline having the desired boiling range and vapour pressure is recovered.

*Moving Bed Catalytic Cracking Process.*

The flow diagram of this process, which is designated as the Thermoform Catalytic Cracking Process (TCC) is shown in Fig. 22.\* In this type of catalytic cracking a mass of catalyst in the form of small pellets or spherical particles moves downward through the cracking reactors. A stream of preheated oil vapours either flows upward counter-currently to the catalyst, or in an alternative operation the vapours may flow downward concurrently with the moving catalyst bed. The carbonised particles are elevated mechanically and then passed downward against rising currents of air to burn off the carbonaceous material, and the regenerated particles are again raised by mechanical means to the top of the cracking reactor.

*Fluid Flow Catalytic Cracking Process.*

This process, representing a radical departure from previous catalytic cracking operations, was developed by the co-operative efforts of the following companies: Universal Oil Products Company, Standard Oil Development Company,

The M. W. Kellogg Company, Shell Development Company, Texaco Development Corporation, Standard Oil Company (Indiana).

In this process the gas-oil vapours are brought into contact with catalyst in finely divided condition. The essential parts and the process flow

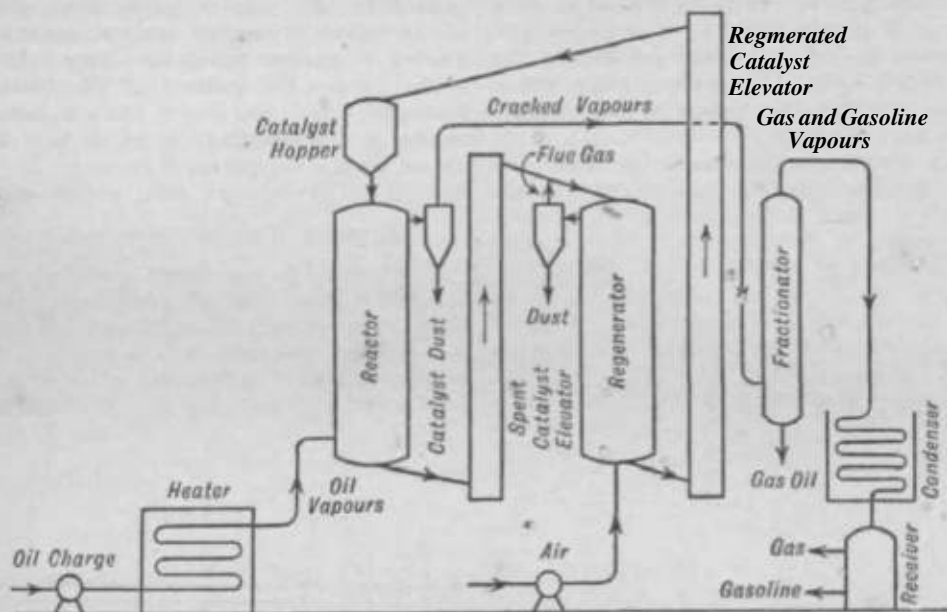

FIG. 22.

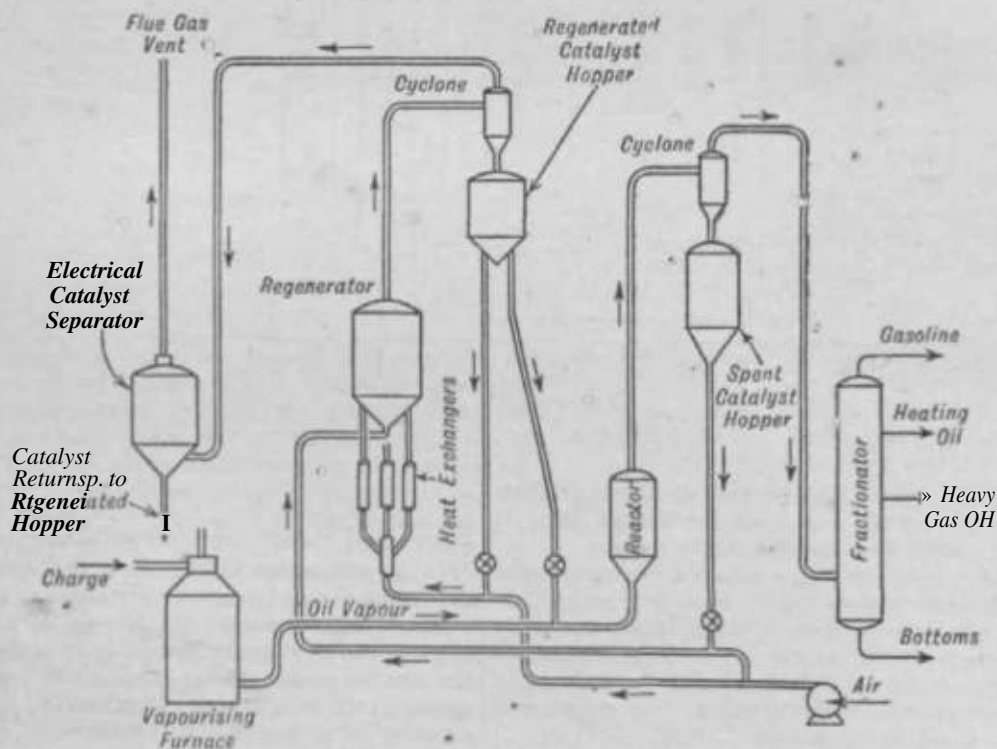

FIG. 23.

in a plant of this character are shown in Fig. 23.<sup>50</sup> The charge is heated and vaporised, and powdered regenerated catalyst enters the stream of oil vapour by gravity, and the mixture passes through a reactor where the cracking takes place, a certain amount of carbonaceous material being

deposited upon the catalyst particles. Oil vapours and catalyst dust pass to a cyclone separator, the oil vapours being fractionated into gas, gasoline, heating oil, heavy gas oil, and fuel-oil bottoms. The spent catalyst flows by gravity from a hopper into a stream of air and into a

regenerator, where combustion of the carbonaceous material takes place, and the catalytic activity of the particles is restored. Considerable heat is generated in the burning of the carbonaceous deposits, and some of this is removed by heat exchangers and a portion of the catalyst is circulated from the regenerated catalyst hopper to the regenerator by part of the air from the source of supply. The finer particles from the regenerator which escape settling in the cyclone following the regenerator are recovered in a succeeding electrical separator and returned to the system.

A flow diagram of a two-stage fluid flow catalytic cracking plant is shown in Fig. 24, the

oil being cracked in a primary reactor and the gasoline separated and retreated to lower its olefin content in a second reactor.

The raw oil charging-stock, usually gas oil, is preheated by heat exchange with a recirculating stream from the first-stage fractionating column (equipment not shown in the drawing), then passed to the catalyst-to-oil heat exchanger shown, where it receives further preheat from a stream of catalyst which circulates between the exchanger and the regenerator. Additional heat is supplied by means of a tubular heater (not shown in the drawing) in which the charge is raised to the temperature required to vaporise the oil. The vapours then enter the reactor

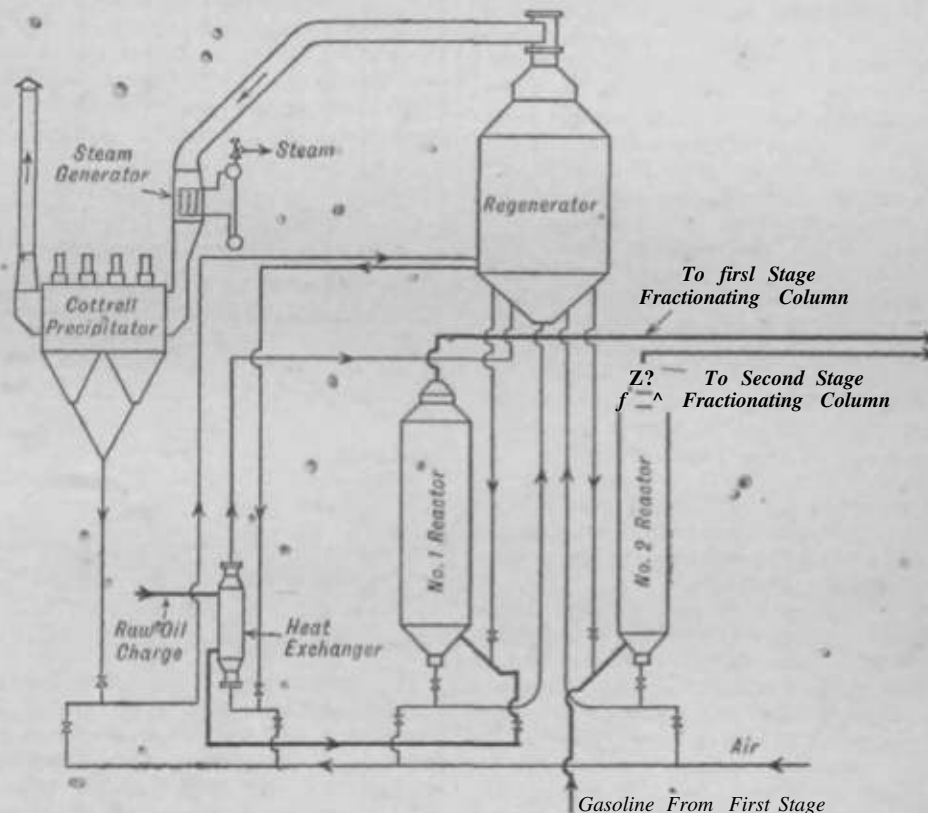

FIG. 24.

where contact is made with the hot catalyst coming from the regenerator. The oil vapours and catalyst flow upward in the reactor.

The vapours leaving the reactor carry some of the catalyst powder with them. The major portion of these catalyst particles is recovered by passing the vapours through cyclone separators and electrical precipitators, and the balance is recovered as a slurry at the bottom of the first stage fractionating column.

The air required for combustion of the carbonaceous material on the spent catalyst enters at the base of the regenerator risers and carries the catalyst upward into the regenerator. The regenerated catalyst flows into the draw-off well down to the two reactors and into the catalyst-to-oil heat exchangers.

The products of the reaction are then fractionated in the first-stage fractionating column

and gas-concentrating equipment\* from which gasoline is returned to the second-stage reactor for treating, usually at a somewhat lower space velocity and temperature. Heat is furnished to the second-stage reactor principally by hot catalyst from the regenerator, the catalyst-to-oil ratio in this stage being relatively high. From the second-stage reactor the treated product passes to the second-stage fractionating and gas-concentrating sections for separation and recovery of the gasoline.

Improved results in respect to both yields and quality of catalytically cracked gasolines are obtained when the recycle stocks are hydrogenated before they are again brought into contact with the catalyst. Hydrogenation saturates both olefins and aromatic hydrocarbons, and in effect returns paraffins and naphthenes to the cracking zone.

*Treatment of Catalytically Cracked Gasolines*

Present aviation-gasoline specifications are such that base stocks of high quality must be relatively low in olefin content and high in *iso*-paraffin and aromatic content. These requirements can be met by catalytic cracking plants in two ways: first, the unit may be operated at relatively low temperatures, 427-482°o. (800-900°P.), in which case a base stock having a low olefin content is produced. However, conversions high enough to correspond to the desired aromatic content are difficult in such an operation on most stocks because of the severity of other operating conditions (pressure, time) necessary and because of relatively high production rates of carbon at the lower temperatures. As an alternative, the cracking operation can be carried out at higher temperatures and higher conversions. This operation produces a base stock which is rich in aromatics but which, unless unusually high conversions and naphthenic stocks are used, contains a higher quantity of olefins than can be tolerated directly in aviation-base stocks. Accordingly, some method of treating this gasoline must be employed.

*Catalytic.*—When the gasoline from high-temperature catalytic cracking is brought into contact with a synthetic silica-alumina catalyst in the temperature range of about 371-482°o. (700-900°F.), a base stock of exceptionally high quality is produced. Not only is the olefin content reduced by hydrogen transfer, but isomerisation also takes place; so that a marked improvement in anti-knock quality results. This operation is highly desirable in many instances, particularly when paraffinic charging stocks are processed. Processes for catalytic retreating of catalytically cracked gasolines form the subject-matter of numerous patents.<sup>52</sup>

*Sulphuric Acid.*—A second method of removing olefins from gasolines is by sulphuric acid treatment. The removal of the olefins and, in the case of high-sulphur stocks, the simultaneous desulphurisation realised, result in marked improvement in susceptibility of the gasoline to increased octane number by the addition of tetraethyl lead. However, the molecular rearrangement of the other hydrocarbon components of the gasoline is not realised, and the improvement in quality is inferior to that obtained in catalytic treating. This difference in quality is first in part by a considerable reduction in the amount of equipment required, and can be minimised further by the operation of the first-stage cracking step at higher conversion levels. Accompanying the acid treatment, of course, is a loss of hydrocarbons and an appreciable consumption of acid.

*Polymerisation.*—A third treating method is a relatively new development known as "poly-treating." This operation comprises liquid-phase treatment of the gasoline in the presence of a UOP solid phosphoric acid catalyst. The results are comparable with those which can be realised by sulphuric treatment, because the principal reaction in both processes is the removal of olefins. The improvement in quality is, therefore, largely a result of the improved lead susceptibility resulting from removal of the olefinic compounds. The prime feature of this

process is the long life of the catalyst, which makes it economically attractive. The high-boiling material produced in this operation is quite satisfactory for catalytic re cracking; thus the volumetric loss of aviation fraction attending the poly-treating operation itself is not chargeable against the combined catalytic cracking and treating operation, as a large part of the bottoms can be recovered as aviation gasoline in the re cracking step.

*Hydrogenation.*—An effective method of reducing the olefin content of catalytically cracked gasolines consists in low temperature hydrogenation, which converts the olefins into paraffins. The hydrogenation of catalytically cracked gasoline at temperatures of 116-121°o. (240-250°F.), at atmospheric pressures using a nickel-on-Kieselguhr catalyst gave the results shown in Table XV. The data indicate that the olefins were almost completely hydrogenated with very little effect on the aromatics and with an increase in octane number.

TABLE XV.

	Charge.	Treated product.
Sp. gr.	0.7370	0.7451
A.P.I. gr.	60.5	58.4
Br. No.	58	2
Octane number *	90.8	92.6
Initial b.p.	39°o. (102°P.)	41°o. (106°F.)
Final b.p.	189°o. (340°P.)	190°o. (342°F.)
Paraffins and naphthenes	33	67
Aromatics	35	32
Olefins	32	1

\* Plus 4 c.c. of tetraethyl-lead per gallon of gasoline.

*Composition of Catalytically Cracked Gasolines.*

The presence of higher percentages of *iso*-paraffin and aromatic hydrocarbons is a distinguishing characteristic of catalytically cracked gasolines in comparison with non-catalytically cracked products. Sufficient data are not available on the yields and qualities of gases and gasolines produced by the three major types of catalytic cracking processes described to afford definite comparison of their commercial merits. The mechanical features of operation are different and the relative composition of gasolines depends upon the oil charged and the conditions of operation, which are varied to produce motor fuel or aviation fuel. However, some data are available which show the hydrocarbon group analysis of gasolines produced by thermal and catalytic cracking respectively, and other data which show the proportion of *iso*-paraffin in low boiling gasoline fractions from thermal and catalytic cracking in comparison with analogous straight-run gasolines. The hydrocarbon group composition of a gasoline from thermal non-catalytic cracking and three catalytically cracked gasolines made by the Houdry Fixed Bed Operation are given in Table XVI.<sup>57</sup> The data show that the gasoline from thermal cracking is higher in olefin hydrocarbons and lower in naphthene and aromatic hydrocarbons.

TABLE XVI.—COMPOSITION OF CBAOKED GASOLINES.

Charge.	Cracking (on coin-mercian scale).	Fraction 10-175°C. (50-347°F.).			
		Para-nns.	Naph-thenes.	Ole-fins.	Aro-matics.
Gas oil,* sp. gr. 0-8816, A.P.I. gr. 29.	Thermal.	53	14	30	3
Gas oil,* sp. gr. 0-8708, A.P.I. gr. 31.	Catalytic.	56	19	9	16
Heavy crack-ing stock from coastal crude . . ?	Catalytic.	39 *	19	29	13
Peavy naph-tha from coastal crude . .	Catalytic.	43	24	5	28

\*Approximately 50:50 mixture of Mid-Continent grade and Gulf Coast grade gas oils.

The composition of the hexane fractions of three typical gasolines is shown in Table XVII.\*<sup>7</sup> The Moparaffins are highest in the catalytically produced gasoline, and lowest in the thermally cracked gasoline, which at the same time contains the highest percentage of n-hexane.

TABLE XVII.—COMPOSITION OF HEXANE FRACTION OF GASOLINES<sup>^</sup>

Hexanes.	East Texas straight-run gasoline, vol. %.	Thermal gasoline, vol. %.	Catalytic gasoline prepared at 427°C. TO
n-Hexane . . .	51	63	9
2-Methylpentane.	32	18	48
3-Methylpentane.	16	16 <sup>c</sup>	27
2:3-Dimethyl-butane . . .	1	3	13
2*-Dimethyl-tane	—	—	0
T&I woparaffins *	49	37	91

The properties of the oils cracked, the yield of motor gasoline and furnace oil, and the properties of the motor gasoline from fluid catalytic cracking of gas oil are shown in Table XVIII."

Table XIX includes data on the quality of aviation gasolines made in fluid catalytic commercial operations using synthetic catalysts, and includes a comparison of the effects of paraffinic and naphthenic feed stocks on the gasolines.\*<sup>8</sup> All products were stabilised to a 7 lb. Reid vapour pressure and all had approximately the same percentages distilled at 145°o. (293°F.) and the same end point. The octane numbers are all above 80, the highest value of 86 being shown by the gasoline from the single-stage high temperature cracking of the naphthenic stock. The lowest octane rating is shown by the hydrogenated gasoline from the single-stage cracking of the paraffinic oil. However, the hydro-

TABLE XVIII.—MOTOB GASOLINE PRODUCTION AND QUALITY FROM FLUID CATALYTIC CRACKING OF GAS OILS.

	East Texas wide cut.	West Texas wide cut.	West Texas heavy.	Coastal wide cut.
Feed properties:				
Sp.gr. . . .	0-8670	0-8855	0-9200	0-9212
A.P.I. gr. . .	31-7	27-3	22-3	221
Sulphur, % by weight	0-48	1-80	2-49	0-63
Product yields (% by volume):				
Motor gaso-line . . .	450	43-2	460	46-2
Furnace oil.	51-2	5-2	51*2	51-2
Motor gasoline properties f:				
Sp.gr. . . .	0-7370	0-7459	0-7459	0-7507
A.P.I. gr. . .	60-5	58-2	58-2	570
A.S.T.M. distillation (% distilled) at:				
70°o.; 158°F.	25-5	18-5	18-5	230
100°o.; 212°F.	57-0	42-0	380	43-5
End point, °o.; *F..	208; 406	204; 400	205; 401	208; 406
Sulphur, % by weight	003	0-18	0-246	0044
Octane No.:				
C.F.R.-M.§ without addition of T.E.L.* . .	80-5	79-4	77-9	80-5
Plus 1/5 ml. T.E.L. per gal. . . .	84-6	830	81-2	84-7
Cracked gas-oil properties t:				
Sp.gr. . . .	0-8762	0-9123	0-9176	0-9218
A.P.I. gr. . .	300	23-6	22-7	220
Sp.gr. Toluene (A.S.T.M. distillation) °c.; °F.. . . .	300; 572	318; 605	318; 605	295; 563

\* Held vapour pressure, 10 lb.; end point, 400°F.  
 t Inspections on product as produced without further treatment.  
 X Tetraethyl-lead.  
 § Motor method.

number of 98-2 after the addition of 4 ml. of tetraethyl-lead per gallon, on account of the complete absence of olefins.

Reactions of Cracking.

Reactions involved in decomposition of hydrocarbon mixtures are extremely complex and have been the subject of extensive investigation and disputes as to their exact character. The composition of most oils subjected to cracking is only incompletely known, and it is difficult to trace the exact mechanisms leading to the formation of observed products, pelydrogenation reactions occur, carbon to carbon bond rupture, and cyclisation and condensation reactions take place involving the primarily formed olefins and cyclic compounds. The formation of low-boiling paraffins and olefins has been attributed to the rupture of <sup>0</sup> » ^ c l ^ m - n to carbon bonds in paraffins wh w ^, e.g., equal amounts of hexanes and hexenes would be formed by cracking a dodecane

TABLE XIX.—TYPICAL PBDUOT QUALITY OF CATALYTIC AVIATION BASE STOCKS (COMMERCIAL OPERATIONS; SYNTHETIC CATALYST).

Type of operation . . . .	Paraffinic feed stocks.				Naphthenic feed stocks.		
	Single-stage.			Two stage.	• Single-stage.		
	Low.	High.	Hydrogenation.*	High.	Low.	High.	High.
Feed stock:		*					
B.P.°C. . . . .	0-8413	0-8443	0-8443	0-8735	0-8560	0-8783	0-8783
A.P.L.S.R. . . . .	36.7	36.1	36.1	30.5	33.8	29.6	29.6
Aviation gasoline:							
Spgr. . . . .	0-7332	0-7531	0-7459	0-7475	0-7479	0-7555	0-7741
A.P.L.S.R. . . . .	61.5	56.4	58.2	57.3	57.7	55.3	61.3
Reid vapour pressure, lb.	7.0	7.0	6.8	7.0	7.0	6.9	6.9
Sulphur, % by weight	0.02	0.03	—	0.03	0.03	0.03t	0.03t
A.S.T.M. distillation, % by volume over at:							
75°C.; 167°F. . . . .	33.5	34.5	28.5	31.0	29.0	28.5	24.0
105°C.; 221°F. . . . .	61.0	56.5	54.0	55.0	53.0	56.5	46.5
135°C.; 275°F. . . . .	84.5	80.0	81.5	77.0	77.5	85.0	75.0
145°C.; 293°F. . . . .	91.0	90.0	91.0	90.0	88.5	92.7	91.4
End point, °C.; °F. . . . .	150; 332	161; 322	159; 318	159; 318	163; 326	159; 319	160; 320
Octane number:							
A.S.T.M.: without addition of T.E.L.§	81.0	82.7	80.4	83.2	81.5	81.7t	80.6t
A.8.T.M.: plus 4 mL T.E.L. per gallon	93.3	91.7	98.2	96.5	94.9	92.6*	97.4*

\* Shows high-temperature gasoline from column 2 after hydrogenation.

t Inspected on pentane-free basis.

‡ Bated with pentanes added for 7 lb. Reid vapour pressure.

§ Tetraethyl-lead.

Olefin formation has also been explained by the direct splitting of hydrogen from paraffins, and aromatic formation by the extensive dehydrogenation and ultimate cyclisation of aliphatic chains and the dehydrogenation of naphthenes. Overall cracking reactions are moderately endothermic, which may indicate the predominance of endothermic dehydrogenation and aromatization reactions over exothermic reactions of polymerisation and alkylation. With increasing molecular weight, paraffin hydrocarbons undergo more carbon-to-carbon-bond splitting and less dehydrogenation. At sufficiently high pressures, some alkylation of paraffins with olefins may occur even in the absence of catalysts. Isomerisation of paraffin hydrocarbon is unlikely in strictly thermal cracking.<sup>65</sup>

Olefins produced as primary products of cracking undergo polymerisation at high temperatures and pressures. At reduced pressures some depolymerisation may occur, and in extensive cracking olefins primarily formed may be either dehydrogenated to diolefins or decomposed to diolefin and paraffins. Cyclisation of olefins may lead to the formation of naphthenes and cyclo-olefins, or aromatic hydrocarbons.<sup>66</sup>

Naphthenes containing six carbon atoms in the ring and having alkyl side chains undergo dealkylation and dehydrogenation to aromatics. The dealkylation takes place as a primary reaction and dehydrogenation as a secondary reaction. Some cycloparaffins having short-chain alkyl groups are stable in the absence of catalysts. High molecular weight alkyl groups undergo further secondary reactions with the formation of paraffins and olefins. Severe conditions may cause some breaking down of the cycloparaffin rings.<sup>67</sup>

Aromatic hydrocarbons play an important role in cracking. Their main reactions involve dealkylation with splitting off of long side chains and condensation of primary radicals to produce paraffins, olefins, and aromatics with alkyl substituent groups of low molecular weight. Condensation reactions occur, between different aromatics and between aromatics and olefins. The polycyclic condensation products formed from simpler aromatics account for the ultimate formation of asphaltic compounds and coke.<sup>58</sup>

The factors involved in the cracking process which determine yields and qualities of products are: (1) the type of oil cracked; (2) temperature; (3) pressure; (4) time; (5) catalysts. The character of the oil charged exerts a marked influence on the properties of cracked products. The relative proportions of the different hydrocarbon groups that are present, and their mutual influence on each other under cracking conditions, determines to a large extent the composition of the gasoline produced and the suitability for re-cracking of the heavier products. The relative proportions and types of paraffins, naphthenes, and aromatics in a primary charge vary with the crude oil from which the charge is obtained. The boiling-point range of the charge has a definite influence on the degree of cracking under a given set of operating conditions. Lower boiling-range charging oils are more difficult to crack and require higher temperatures, pressures, and times for comparable yields of products. Thus a straight-run gasoline may require temperatures as high as 592-650°C. (1,000-1,100°F.) for its cracking or reforming, while a fuel-oil residuum may be extensively cracked at temperatures of 427-482°C. (800-900°F.). A charging stock of wide boiling-range is more difficult to crack



successfully than one of narrower range, since the optimum conditions for the lighter components are considerably different from those suited to cracking the heavier portions of the oil. The boiling range of the charge determines the phase under which cracking occurs. If the temperatures employed are above the critical for the major portion of the hydrocarbon components, cracking will occur in vapour phase. Higher boiling oils will undergo decomposition under mixed phase conditions. No commercial cracking process operates completely under liquid phase conditions, since cracking produces low-boiling vapours and gases, and mixed phase conditions soon obtain.

Temperature is the most important single factor in cracking. The rates of cracking are usually based on the production of gas and gasoline, and many calculations have been made to obtain some definite relationship between cracking rates and temperature. While some of the expressions developed are of interest in showing the order of the rate-increase with temperature, no expression is applicable to all cases. A temperature must be chosen at which cracking is negligible for all stocks, and the temperature effects dissociated from the effect of pressure and time, which makes experimental confirmation of any equation extremely difficult. Between temperatures of 400° and 620° (750° and 1,150°F.), numerous estimates indicate that the rate of cracking doubles for an increase of about 14° (25°F.) in temperature. Since the relative amounts of gas and gasoline produced vary not only with charging stocks but with temperature, pressure, and other influences, such statements should only be considered as approximations. As the temperature rises, the rate of increase in cracking decreases.

The effect of increased pressures on the rate of cracking and the character of cracked products is complicated by the difficulty of dissociating pressure effects from the concurrent effects of other variables. As pressures are increased, less vaporisation occurs, and there is generally a lower yield of gaseous products. The use of super-atmospheric pressures in cracking plants permits the use of higher temperatures while maintaining mixed phase conditions, since at atmospheric pressure the constituents of a charging oil are cracked or vaporised and decomposition reactions occur mainly in vapour phase. Higher pressures apparently favour the formation of gasolines containing lower percentages of olefins, but this again depends upon the nature of the charging stock, since olefins are produced mainly from the paraffinic constituents. In a cracking coil charged at a fixed rate, higher pressure increases the time during which the oil is at cracking temperature due to the higher ratio of liquid to vapour. Increased pressure is supposed to favour secondary polymerisation reactions among primarily formed olefins, although many experimental data have been accumulated which contradict this assumption. Condensation reactions are favoured at high pressures since gasolines thus produced show generally higher percentages of naphthene hydrocarbons.

Low pressures corresponding to vapour-phase conditions favour, dehydrogenation and cyclisa-

tion reactions, and hence formation of hydrogen, normally gaseous hydrocarbons and aromatic hydrocarbons.

The time factor in cracking is an extremely complex variable to calculate. During passage of charging oils through a tube, vaporisation, cracking, and gas formation occur so that the total volume of the fluid stream progressively increases. Since the rate of increase is not strictly a linear function, the volume at a given point cannot be determined and the average volume is never the arithmetic mean of the entering volume of charge and the outgoing volume of products. In commercial cracking-coils both temperature and pressure increase along the line of flow to further complicate computations of the time factor. Sufficient time is never given for reaching equilibrium at the given temperature and pressure, but a charging rate is adopted which yields the best quantity and quality of gasoline under the chosen temperature and pressure of operation.

The precise effects of catalysts in cracking are even more difficult to assess than in many other catalysed processes of lesser complexity. Catalysts are employed both to permit the use of lower temperatures and pressures, and to modify the course of the cracking reactions so that products of more desirable properties are obtained. Aluminum chloride was one of the first catalysts to be employed in the cracking process. This catalytic material produced gasolines containing minimum amounts of unsaturated hydrocarbons and composed mainly of paraffins and cycloparaffins. However, gasolines of this character did not possess as high anti-knock values as those containing olefins and aromatics produced by strictly thermal cracking operations. This deficiency in quality along with the costs of regenerating the spent aluminium chloride sludges ultimately led to the abandonment of the commercial process.

Other catalysts employed in cracking have been various metals and metal oxides, particularly ferric oxide. These types of catalysts, particularly the metals, cause rapid and extensive decompositions which are difficult to control. Coke deposits are soon formed and the catalytic surfaces are rendered inactive. None of the processes employing such catalysts have proved practical except those employing aluminum oxide.

In a later development, certain types of refractory silicate catalysts have been developed which combine stability under high temperatures of cracking and catalyst reactivation, and modify the extent and course of the cracking reactions to produce gasolines having higher octane ratings than those obtainable by the operation of the best non-catalytic processes. The first successful catalysts of this type were certain natural or activated aluminium silicates, particularly Bentonite and Montmorillonite (v. Vol. I, 663(2)).

One of the major developments in catalytic cracking has been the production of synthetic catalysts of a refractory character consisting essentially of composites of precipitated silica and precipitated alumina, with the latter in minor proportion. The composites may be produced either by simultaneous co-precipitation of



hydrated silica and hydrated alumina, by separate precipitation and mixing, or by precipitating one component in a suspension of the other. Co-precipitation may be practised by mixing sodium silicate and sodium aluminate solutions in proper proportions and adding a mineral acid until the pH value is approximately 6. A better method of co-precipitation is by the addition of ammonium chloride to a mixed solution of an alkali metal silicate and alkali metal aluminate, or an alkali metal silicate and an aluminium salt.

Several alternative methods of separate precipitation and mixing of silica and alumina are employed. Hydrated silica is precipitated by the acidification of alkali metal silicate solutions, and hydrated alumina by the addition of ammonium hydroxide to aluminium salt solutions. The separately prepared hydrates can be mixed to form the composites, or the silica may be separately precipitated, washed, and suspended in the aluminium salt solution after which hydrated alumina is thrown down by the addition of alkaline reagents such as ammonium hydroxide. The silica-alumina composites are washed with water, weak acids, ammonium salts, or heavy metal salts to effect the substantially complete removal of alkali metal ions. The water washing removes readily soluble salts, acids such as sulphuric or hydrochloric react with and dissolve alkali metal ions absorbed in or combined with the silica or alumina, and the bases in the ammonium or heavy metal salts displace the same types of ions. Subsequent heating drives out water, acids or ammonia and leaves small amounts of oxides of heavy metals if these have been a displacing agent. The catalytic activity of silica-alumina composites is greater than the sum of the activities of the silica and alumina used alone, this being a definite case of joint promotional activity, coming under the heading of synergism.

There are certain processes, most of them catalytic, which are used to increase the yield and quality of motor fuel from cracking. Gases from cracking plants contain substantial amounts of ethylene, propylene, and butylenes, although there are larger amounts of ethane, propane, and butanes. Catalytic processes have been developed which synthesise high octane rating hydrocarbons from these by-products, which for a long time were utilised only for their fuel values. The synthetic hydrocarbons produced by these processes have higher anti-knock ratings than the cracked gasolines themselves, and consequently they increase both yield and quality of the motor fuel. At present the hydrogen, methane, ethane, and ethylene in cracked gases are used principally for fuel, but the propane, propylene, butanes, and butylenes are extensively converted to motor fuels or other products. The reactions employed include polymerisation, alkylation, dehydrogenation, and isomerisation.

The gases from cracking as well as those from natural gas and petroleum gases are also used to make synthetic products other than motor fuel. *E.g.*, benzene is alkylated with ethylene to produce ethylbenzene, which is then dehydrogenated to styrene for use in synthetic rubber

manufacture. Both n-butane and n-butylenes are dehydrogenated to produce butadiene, another base material required in synthetic rubber manufacture.

n-Butane is isomerised to isobutane which is alkylated with olefins to produce iso-octanes and other high anti-knock paraffin hydrocarbons. Isomerisation of pentanes and hexanes furnishes isopentane for aviation fuels, and branched chain hexanes of high anti-knock value. The dehydrogenation of cyclohexane and methylcyclohexane present in selected petroleum distillates yields benzene and toluene in quantities separable by solvent extraction and azeotropic distillation.

#### POLYMERISATION.

By forming polymers of the propylene and butylenes present in cracked gas mixtures, the yield of cracked gasoline, based on the oil cracked is augmented by 2-3%. Of the normally gaseous olefins, isobutylene is the most easily polymerised and ethylene is the most difficult, n-butylene and propylene are intermediate in their activity. Isobutylene in admixture with other gaseous olefins may be selectively polymerised to form trimethylpentenes (principally the 2:2:3- and 2:2:4-compounds), which are readily hydrogenated to the paraffin hydrocarbons of similar structure which possess octane numbers from 95 to 100. Other processes are concerned with polymerisation of all the olefins present in cracked gases to produce gasolines having octane numbers from 80 to 82. The hydrocarbon mixtures most commonly utilised in polymerisation processes are those containing principally propane, propylene, butanes, and butylenes, which are obtained in stabilising cracked gasolines to reduce their vapour pressure to the usual specified value of 10 lb. Reid. A typical analysis of such a mixture obtained from the stabiliser of a thermal cracking plant is given

in Table XXI\*»

TABLE XX.

	Mol-%.
Methane.	11.0
Ethylene.	6.0
Ethane.	19.0
Propylene.	18.5
Propane.	35.5
Butylenes.	5.0
Butanes.	5.0

#### Thermal Processes.

The liquid products obtained by subjecting cracked-gas mixtures to uncatalysed thermal treatment at temperatures of 471-693°o. (880-1,100°F.) under pressures of 800-1,000 psi.<sup>60</sup> are not all formed by olefin polymerisation reactions. Such products contain, in addition to normally liquid olefin polymers, naphthenic, aromatic, and paraffin hydrocarbons. Pressures of about 1,000 psi. produce more olefinic products, while the use of temperatures of 649-704°o. (1,200-1,300°F.), and pressures under 100 psi. produce fewer liquid olefins and higher amounts of aromatics, owing to dehydrogenation and cyclisation reactions. The thermal process is applied to paraffinic gas

mixtures which are first cracked to produce olefins in a primary operating stage, and then subjected to higher pressure in a secondary stage to effect polymerisation and condensation reactions. In the poly-forming or gas reversion process, mixtures of propane, propylene, butanes, and butylenes are dissolved under pressure in a gasoline which is to be reformed, and polymerisation of the olefins occurs during reforming, so that the reformed products contain thermal polymers. The reforming conditions are not severe enough to cause appreciable cracking of the dissolved paraffins.

*Catalytic Processes.*

Catalysts which accelerate and control the polymerisation of normally gaseous olefins include: (1) sulphuric acid; (2) solid phosphoric acid; (3) metal pyrophosphates; (4) clays and fuller's earths.\*

*Sulphuric Acid.*—Sulphuric acid of 60-70% concentration selectively absorbs isobutylene,

from cracked gas mixtures at ordinary or slightly elevated temperatures.<sup>1</sup> The sulphuric acid contains, in addition to the *tert.*-butyl ester, a certain amount of *tert.*-butyl alcohol which has been assumed to exist in the form of an "alkoxonium" ion ( $C_4H_9OH_2^+$ ). The acid is then passed through a coil and heated to 100°o. (212°F.) to form diisobutylene and regenerate the acid. The diisobutylene hydrogenates to 2:2:4-trimethylpentane, two-thirds of the isobutylene in the cracked gas mixture being converted to this isooctane.

Fig. 25 shows a plant flow for the selective polymerisation of isobutylene to dimar using "cold" sulphuric acid at temperatures of 20-35°o. (<68-95°F.). A mixture of four-carbon-atom hydrocarbons containing isobutylene, n-butylene, isobutane, and n-butane is pumped into the plant and mixes with recirculated acid containing some *tert.*-butyl alcohol. A rapid circulation is maintained in a primary water-cooled reactor after which the acid-hydrocarbon mixture

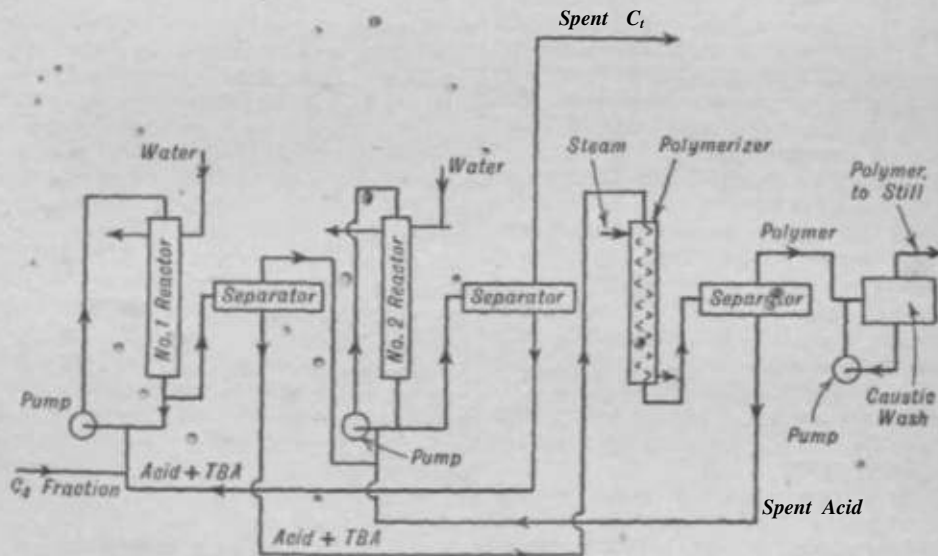

FIG. 25.

passes to a separator. The hydrocarbon layer from the primary separator passes to a second reactor where it reacts with recirculated acid from a final separator. Complete absorption of isobutylene, n-butylene, and normal butylenes are removed and returned to the primary reactor. The acid layer from the primary separator is heated with steam in a polymerizer to form diisobutylene and regenerate acid for the second reactor. The octane number of the isobutylene mixture, which consists principally of 2:4:4-trimethylpentene-1 and 2:4:4-trimethylpentene-

of the hot acid polymerises all of the isobutylene and a portion of the n-butylenes, and while the octane number of the polymer products is slightly lower (about 82), the yields from a given gas mixture are almost doubled. The yield and quality of the polymers is subject to control by varying acid strength between 83 and 72%, and varying the temperature between 74° and 100°o. (165° and 212°F.). The completion of the reactions usually requires between 10 and 15 minutes; during which rapid circulation of acid and hydrocarbon is maintained in the reaction zone.

Fig. 26 is a flow diagram of a hot sulphuric acid polymerisation plant. A charge consisting of butanes and butylene is introduced into an acid recirculating line and pumped through a reactor cooler which prevents undue temperature rise. The mixture of acid and hydrocarbons is then passed into a reactor tank and then into a reactor separator in which a hydrocarbon layer and an acid layer form. A portion of the acid-

In the "hot" sulphuric acid process a 65% acid is used at temperatures of 88-93°c. (170-200°F.). The acid and the cracked gas mixture continuously react in a mixing device, and the transitory esters and alcohols formed by the interaction of butylenes and the acid are rapidly decomposed so that in effect olefin polymers are formed by true catalysis. The use



hydrocarbon mixture is recirculated, with all of the acid layer, along with some fresh acid. The hydrocarbon layer from the separator passes through a reactor product cooler and then to a final acid separator from which spent acid is withdrawn. The hydrocarbon layer is neutralised with sodium hydroxide and debutanised. The polymer and sodium hydroxide solution are then passed through a hydrolyser time-tank for the breaking up of hydrolysable acid compounds; the hydrocarbon layer from a hydrolyser separator is passed through a second

debutanizer and the polymers are still tilted to recover a dimer product consisting of a mixture of octenes. The yield of octenes is about equal to twice the isobutylene content of the feed stock when there is more n-butylene than isobutylene present in the original stock, which is usually the case.

The comparative results obtained in polymerising butylenes with about 65% sulphuric acid at different temperatures is shown in Table XXI. Comparing the effect of the acid on the same butylenes and butane mixture in the

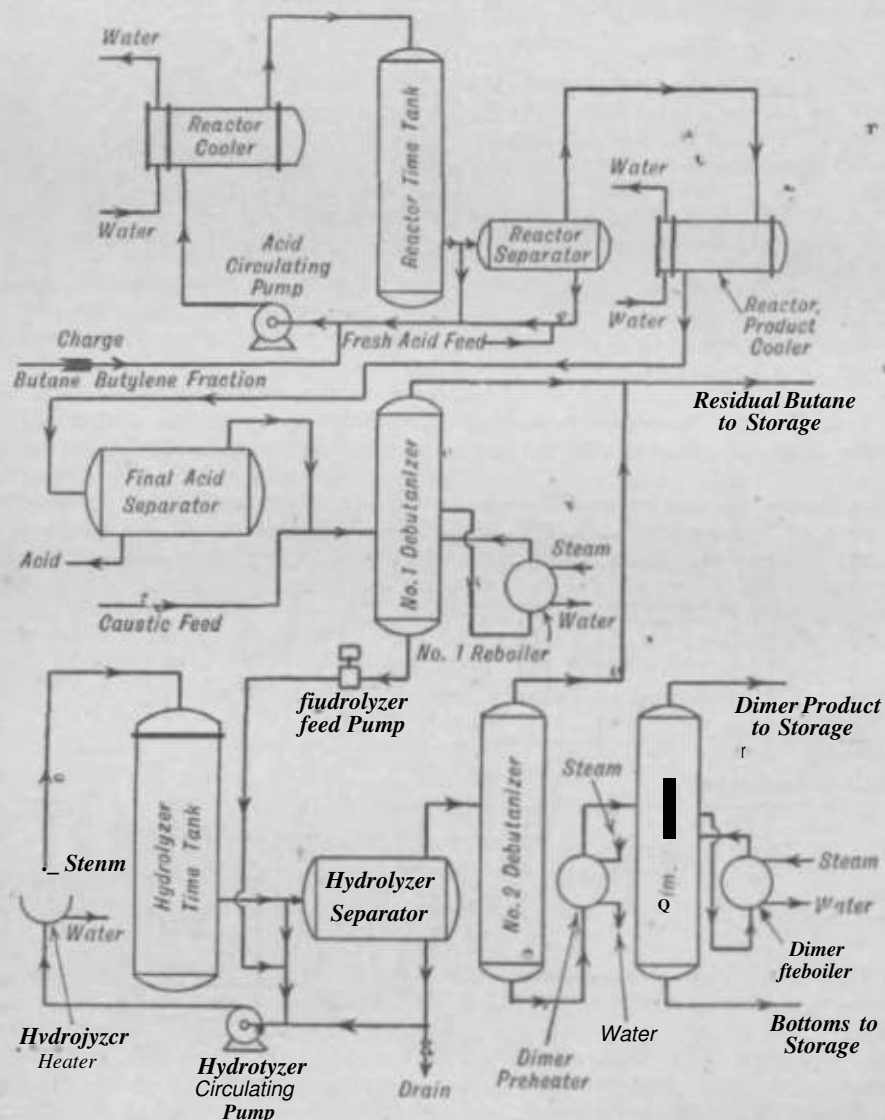

FIG. 26.

first two columns, less polymer was produced at the lower temperature but the octane rating of the hydrogenated octenes was higher, indicating a more selective polymerisation of isobutylene to 2:2:4-trimethylpentene. At the two higher temperatures employed, all of the isobutylene was polymerised and 8-9 times the amount of normal butylenes, although the octane rating of the hydrogenated polymers averaged 99.

"Solid Phosphoric Acid":—V. N. Ipatieff and associates, working in Universal Oil Products Company laboratories, discovered that phosphoric acids and "solid phosphoric acid"

catalyse the polymerisation of gaseous olefinic hydrocarbons. The mechanisms of the reactions are essentially the same as those which take place when employing sulphuric acid. At low temperatures esters are formed, and at high temperatures they are decomposed to yield olefin polymers. In polymerisation plants operated as adjuncts to commercial cracking plants, solid granular phosphoric acid catalysts are employed which consist of a major proportion by weight of an acid approximating to the pyro-acid,  $H_4P_2O_7$ , in composition and a siliceous material. In such

TABLE XXL—COMPARATIVE EFFICIENCY, COLD-AOHD AKD HOT-AOH) POLYMERISATION.

	acid 66% (88-)	I. 65% acid, BOM. (170°F.)	II. 66% acid, flo°o. (104°F.)
Feed composition:			
isoButylene, % by weight	18.5	18.5	01
n-Butylene, % by weight	280	28.0	20.6
Butanes, % by weight	63.5	63.5	70.3
Products:			
isoflutyleno, %	2.4	0	0
n-luylenes, %	26.5	15.1	11.1
Butanes, %	53.5	53.5	70.3
polymer, %	17.5	31.4	18.4
isoButylen* polymerised, %	87.0	100.0	100.0
n-Butylene* polymerised, %	50	46.0	44.5
Total olefins polymerised, %	37.5	67.5	61.8
Composition of polymer:			
Octanes, %	750	88.0	92.0
Octane rating of hydro* genated octenes	UKM)	00-2	SS-8

composites, a large proportion of the acid is present in the form of phosphoailleate complexes.

In the manufacture of such materials, pyrophosphoric acid and diatomaceous earth are mixed to a pasty consistency and the paste is

extruded and cut into short lengths. The catalysts are gradually heated to 500°C. (932°F.), and then with steam at about 300°C. (572°F.) to hydrate the acid to optimum composition. The catalyst particles are used as filler for a chamber through which olefin-containing gases are passed at temperatures of 150–260°C. (300–500°F.), and pressures of 100–400 psi. Gases to be treated with "solid phosphoric acid" are first purified to remove amines before coming in contact with the catalyst, since the presence of amines presents complications. After a period of service during which the catalyst becomes coated with carbonaceous deposits, the stream of gas is diverted to a chamber containing unused catalyst, and the spent catalyst is removed and replaced by fresh material.

Fig. 27 shows the flow in a polymerisation

used, depending upon the size of cracked gas mixture being admitted at a temperature of 149–204°C. (300–400°F.). The temperature rises in the catalyst chambers due to exothermic character of the polymerisation reaction. The liquid products are stabilised and the unpolymerised olefins returned to further use. The flow of gas, depending upon its olefin content

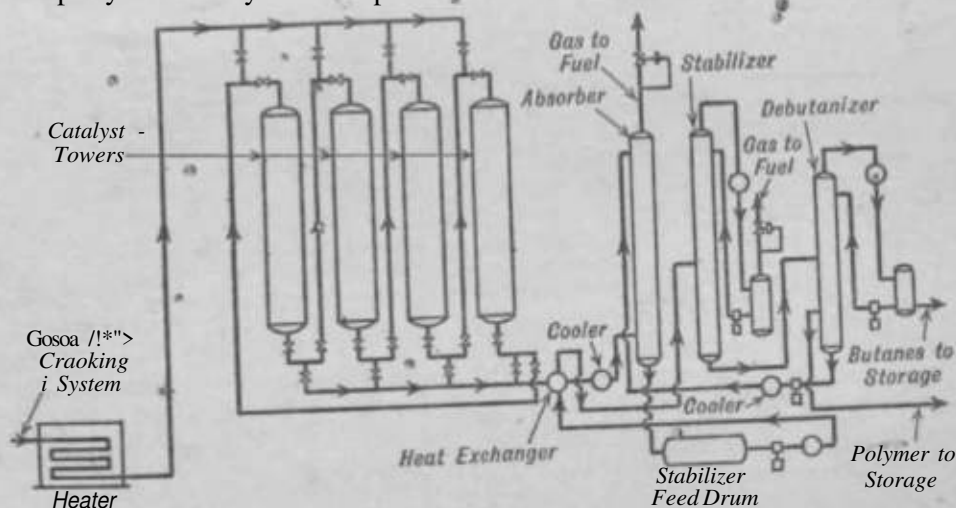

FIG. 27.

The operating conditions and yields of products from a plant similar in construction to that in Fig. 27 operating upon a gas mixture obtained in reforming a Mid-Continent straight-run gasoline are given in Table XXII. Such a polymerising operation produces maximum yield\* of polymer for blending with refinery gasoline and is known as "non-selective operation." In the process gas from the cracking plant stabiliser which contained 0-8% of hydrogen sulphide was first treated with sodium hydroxide solution at 66°F. (150°F.) to reduce the hydrogen sulphide content to below 0.01%.

In order to polymerise isobutylene selectively

to octene temperatures pressures mixtures containing essentially only butylenes. When treating gases containing propylene and butylenes with solid phosphoric acid catalyst, the octane rating of the product is in general inversely proportional to the temperature employed, the yields of polymer following the opposite rule. By polymerising isobutylenes with a limited amount of n-butylenes, "codimer" is produced, which when

TABLE XXII.

Operating conditions:		
Pressure, psi	160	
Temperature	246°C. ; 475°F.	
Inlet gas rate, cu. ft. per hr.	3,520	
Outlet gas rate, cu. ft. per hr.	2,617	
Higher olefin content of inlet gas: propylene and butylenes, %	£4.4	
Higher olefin content of outlet gas: propylene and butylenes, %	9.7	
Olefin polymerisation: propylene and butylene, %	71.0	
liquid polymer production: gallons per 1,000 cu. ft.	3.8	
Properties of crude liquid polymer:		
Sp. gr.	0.7121	
A.P.I. gr.	67.2	
Gum, mg. per 100 c.c. (copper dish)	51	
Gum, mg. per 100 c.c. (air jet)	10	
Octane number (C.F.R. motor method)	82	
Boiling vapour pressure at 38°C. (100-K), lb/g	10.6	
100 c.c. A.S.T.M. distillation:		
Initial b.p.	34 °C. 94 °F.	
% distilled over:		
10	70	158
50	102	215
80	167	333
<b>Sod point</b>	213	Hi

hydrogenated yields "hydrocodimer" which has an octane number of about 92. In commercial plants, two different sets of operating conditions are employed in the manufacture of

codimer. In one, a reactor inlet temperature of 166°C. (330°F.) and a pressure of 500 psi. U employed, and ^JI the other inlet temperature of 182°C. (360°F.) and a pressure of 1,100 psi. Under the second set of operating conditions, more liquid phase is present and a washing effect maintains catalyst activity for longer periods of time. Hydrocodimer consists principally of woctanes and is an important constituent of aviation gasoline blends. During the Second World War, polymerisation plants originally designed for producing polymer gasoline have been operated at reduced temperature to produce codimer to be converted into aviation gasoline by hydrogenation. Since the war ended, most of these plants have returned to higher temperature operation which produces polymer gasoline by polymerising propylene and the butylenes present in C<sub>8</sub>, C<sub>1</sub> hydrocarbon fractions from cracking plants.

Fig. 28 shows diagrammatically the process flow in a plant for producing woctanes from butanes." The butanes are first dehydrogenated to butylenes, hydrogen is evolved from an absorber using heavy polymer as absorbent, and hydrocarbons boiling lower than butylenes are distilled from a succeeding "distillation" butylenes and unconverted butanes are distilled from the absorbent and passed to a polymerising plant operated under proper conditions to pro-

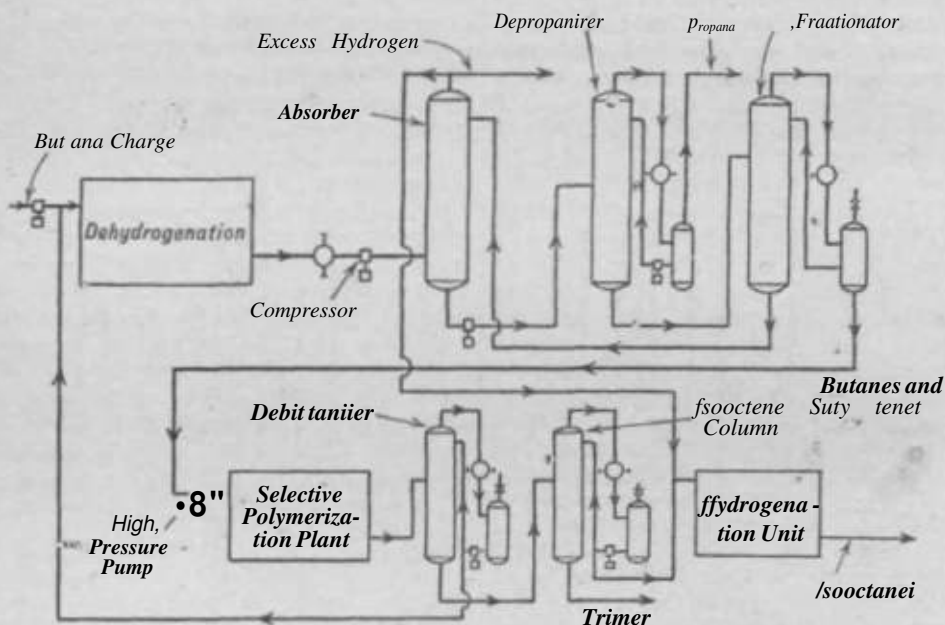

Fig. 28.

dupe woctenes. Residual butanes are distilled from the liquid products and recycled to the primary dehydrogenation step. The tsooctenes are distilled leaving heavier hydrocarbons as a residue and then converted to woctanes by hydrogenation in the presence of nickel catalyst at a temperature of about 160°C. (320°F.) and a pressure of 75 psi-

woButylene is also polymerised to high molecular weight substances having rubber-like properties. This produces the commercial product known as "Vislax" which is formed by the polymerisation of uobutylene at low tem-

peratures with boron trifluoride. "Butyl" rubber is a mixed polymer of about 98% wobutylene and 2% iaoprene. "Vistanex" cannot be vulcanised, although "Butyl" rubber is capable of vulcanisation. The latter synthetic is highly resistant to deterioration by air, ozone, light, strong chemicals and many oils and solvents, and is highly impermeable to air and other gases.

Any ethylene present in cracked gases or fractions thereof is polymerised only to a minor extent in processes operated to produce gasoline polymers, as it forms relatively stable esters with both sulphuric and phosphoric acids.



However some processes using other catalysts are able to produce controllably high molecular weight substances such as "Fdythene." This material is a plastic which is used as insulating material on high frequency cables. "Polythene" is thermoplastic and can be readily moulded by injection or by compression, or extruded to form sheets, films, fibres, and tubes. It is also used in making collapsible tubes for food and cosmetics. Owing to its unreactive character, it is used in gaskets and battery parts. It can be deposited as a waterproof coating by flame-spraying or from solutions, and it has valuable adhesive properties.

**Metal Pyrophosphates.**—The pyrophosphates of copper, zinc, magnesium, and mercury, and the orthophosphate of cadmium can be used for polymerising normally gaseous olefins. Commercially, the copper compound is the only one employed. The operating procedure is similar to that employed with the solid phosphoric acid catalyst.

**Clays and Fuller's Earth.**—Granular absorbents can be used to polymerise olefins and diolefins. However, they are not used commercially for the production of motor fuel from the olefins, in cracked gas mixtures.

Granular fuller's earth has been used for a long time in removing diolefinic gum-forming constituents from cracked gasolines. In the Gray vapour-phase process, the vapours of approximate gasoline boiling-range from the fractionator of a cracking plant are passed through stationary beds of fuller's earth to form heavy liquid polymers which are drawn from the treaters. In some cases, this treatment is adequate for the production of marketable gasoline direct from the cracking plant.

Polymerisation of olefinic gases to polymer gasolines has been brought about experimentally by contact with certain natural and synthetic aluminium-silicates.<sup>71</sup> The natural products are bentonites and montmorillonites and polymerisation can be brought about at moderate temperatures of from 160 to 250°c. (302 to 482°F.). The synthetic materials are hydro-aluminium silicates or the composites of silica and alumina used as cracking catalysts and are made by combining major proportions of silica gels with alumina gels in various ways. Prepared silica-alumina complex composed of about 10 parts of silica is effective at 165°c. (329°F.) and 700 psi. pressure in producing a yield of about 35% of polymer from a mixture of butylenes. The regenerated catalyst, after burning off carbon deposits, shows higher activity than the fresh material and produces polymer in about 65% yield based on the butylenes treated.

DEHYDROGENATION.

In the treatment of petroleum fractions to improve their properties or convert them into more valuable products, dehydrogenation reactions, both thermal and catalytic, are of great importance. A certain amount of dehydrogenation occurs in thermal and catalytic cracking and accounts in part for the observed yields of olefins and aromatics. By the catalysed dehydrogenation of butanes, the corresponding butylenes

are produced, and by the further dehydrogenation of *ra*-butylenes butadiene is formed. The catalytic dehydrogenation of cycloparaffins produces the corresponding aromatics so that, e.g., benzene is produced from cyclohexane and toluene from methylcyclohexane.

Dehydrogenation of Paraffins.

Normally gaseous paraffins comprising ethane, propane, and the butanes undergo dehydrogenation in the absence of catalysts at temperatures of 600-900°c. (1,112-1,292°F.), although better yields of olefins are obtained when catalyst is employed.<sup>72</sup> The commercial catalysts for dehydrogenating gaseous paraffin or olefin hydrocarbons are mixtures of aluminium oxide and chromium sesquioxide (Cr<sub>2</sub>O<sub>3</sub>). In such mixtures the chromium oxide is in minor proportion, usually less than 12% by weight. Pure chromium oxides are less efficient since they are short lived. Other oxides of the sixth group of the periodic system, such as molybdenum oxides and tungsten oxides, are effective and to a lesser extent oxides of vanadium, representative of the elements in the left-hand column of the fifth group. Alumina-chromia catalysts are highly selective in dehydrogenating the gaseous paraffins at temperatures within the range of 450-750°c. (842-1,382°F.) at ordinary or slightly super-atmospheric pressures. Highest yields of mono-olefins and minimum yields of by-products are obtained when the conversion per pass is held below 30% and the unconverted paraffin is recycled after separation of the olefin. In commercial practice, the catalysts are used for limited periods of time of about 1 hour, then decarbonised by oxidising gas mixtures to re-activate them for further service.

In catalytically dehydrogenating paraffins, the optimum temperature for olefin production is lower as the molecular weight increases. E.g., using alumina-chromia catalyst at atmospheric pressure, the best temperatures for ethane are 650-700°c. (1,202-1,292°F.), for propane 500-650°c. (1,022-1,202°F.), and for butanes 525-580°c. (977-1,076°F.). The optimum conversions per pass of the lower molecular weight paraffin hydrocarbons have been given as follows:<sup>73</sup>

Ethane.	9.5
Propane.	28.2
n-Butane	62.3
isoButane.	600

As molecular weight increases, carbon to carbon bond splitting increases and increased amounts of decomposition products are obtained.

The dehydrogenation process is employed commercially to increase the olefins available for polymerisation to gasoline and for the alkylation of aromatics and cycloparaffins. Dehydrogenation of butanes is employed to produce butylenes needed in the manufacture of *iso*-octanes, in the alkylation of isobutane to form aviation alkylate, and for further dehydrogenation to butadiene. The products are butylenes, hydrogen, unconverted butanes, and small percentages of methane, ethane, ethylene, propane, and propylene. By limiting the conversion per pass to 30%, ultimate yields of butylene are of the order of 90%.

Fig. 29 shows the now in the Universal Oil Products Company butane dehydrogenation process.\* The butane is heated to a temperature of 510-538°C. (B50-1,000°F), and dehydrogenation takes place during passage through a reactor containing alumina-chromia catalyst while the catalyst in a parallel reactor is undergoing reactivation. The dehydrogenation pro-

ducts undergo heat exchange with the charge and are washed with oil in a gas scrubber. Dehydrogenating reactions are endothermic and the reactors are of the heat exchanger type with heat being transferred from the catalyst in the reactor undergoing regeneration to the processing reactor by means of a circulating fluid such as flue gas or molten salt mixture.

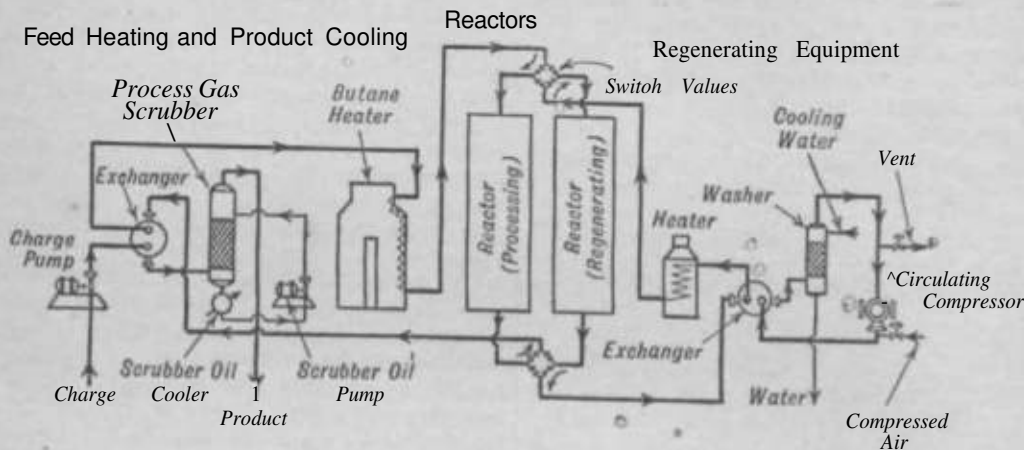

Fig. 29

The principal data obtained in dehydrogenating mixtures are shown in Table XXIII. One mixture was principally n-butane and another was principally isobutane.

TABLE XXIII.

	n-Butane.	iso-Butane.
Space velocity, per hour.	1,450	1,320
Average temperature of catalyst, °K; °F.	631; 987	538; 1,000
Inlet pressure, psi.	62	60
Outlet pressure, psi.	18	5
Inlet gas:		
Composition (mol. %):		
C <sub>3</sub> H <sub>8</sub>	10	4.6
iso-C <sub>4</sub> H <sub>10</sub>	16.7	77.1
n-C <sub>4</sub> H <sub>10</sub>	82.3	18.3
Outlet gas:		
Composition (mol. %):		
H <sub>2</sub>	18.1	18.4
CH <sub>4</sub>	1.7	1.8
C <sub>2</sub> H <sub>4</sub> and C <sub>2</sub> H <sub>6</sub>	0.19	—
C <sub>2</sub> H <sub>4</sub>	0.9	1.2
C <sub>2</sub> H <sub>6</sub>	1.1	4.4
n-C <sub>4</sub> H <sub>8</sub>	3.2	13.3
i-C <sub>4</sub> H <sub>8</sub>	17.0	3.4
C <sub>4</sub> H <sub>10</sub>	56.7	57.5
Conversion (mol. C <sub>4</sub> H <sub>8</sub> converted per 100 mol. C <sub>4</sub> H <sub>10</sub> charged)	28.1	24.9
Efficiency (mol. C <sub>4</sub> H <sub>8</sub> per 100 mol. C <sub>4</sub> H <sub>10</sub> converted)	91.0	88.0
Yield per pass (mol. C <sub>4</sub> H <sub>8</sub> per 100 mol. C <sub>4</sub> H <sub>10</sub> charged)	26.0	21.8

The gas mixtures were passed over alumina-chromia catalyst at the temperatures and pressures indicated, and the yields of 26.0 and 21.8% of butylenes were obtained in the two runs with conversion efficiencies of 91 and 88% respectively. Recycling of unconverted butanes gave ultimate butylene yields of 85%.

### Diolefins from Paraffins or Mono-olefins.

By further dehydrogenation of mono-olefins produced in dehydrogenating paraffins, satisfactory commercial yields of diolefin hydrocarbons are obtained. Thus, normal butylenes resulting from the dehydrogenation of normal butane may react in a second process stage with a dehydrogenating catalyst to produce yields of butadiene of around 26%. Using alumina-chromia catalyst, a temperature of 510-538°C. (950-1,000°F.), pressures of one-tenth to one-fifth atmospheres absolute, and a space velocity of 400-600 are employed. By recycling of unconverted butylene, ultimate yields as high as 85% are obtainable.

As a variation of this two-stage procedure, butadiene is produced in a single-stage process, absolute yields of 25 to 30% are obtainable when normal butylenes are present in contact with the catalyst.

SEES process for manufacturing butadiene by dehydrogenation of butane, catalysts of the alumina-chromia type are employed and a butane-butylene fraction in



recycled after separation of butadiene.<sup>71</sup> The reactors utilise the adiabatic principle, storing heat produced in the regeneration cycle in an inert material mixed with the catalyst and releasing the stored heat to the reacting hydrocarbons in the dehydrogenation period. Temperatures of 550-593°C. (1,050-1,100°F) and absolute pressures of about 2-5 psi. are used. Composition of the charge to the dehydrogenating reactor, the composition of the products from the unit along with the temperature, pressure, and charge rate are shown in Table XXIV.

TABLE XXIV.—HOUDSY SINGLE-STAGE BUTADIENE-BUTYLENE-BUTANE PROCESS.

Operating conditions:		
Catalyst temperature	515°C.,	1,070°F
	(average)	
Pressure, inches Hg.	4.9	
Charge rate, space velocity	2.7	
Yields, % weight:		
	Charge.	Endoot.
C <sub>5</sub> and lighter	2.2	3.7
n-Butane	0.9	1.9
n-Butylene	2.1	2.6
w-Butylene	23.1	23.1
n-Butane	67.0	53.3
Butadiene	3.8	12.7
C <sub>5</sub> plus	0.9	1.7
Coke	—	1.2
	100.0	100.0

\* Volume of gas per volume of catalyst space per hour.

A simplified flow chart of the single-stage unit is shown in Fig. 30.

The n-butane is preheated in a furnace along with the unconverted butane-butylene cut recycled from the butadiene extraction unit. The catalytic battery comprises six reactors, although it could be built with three reactors of same total capacity.

After passing through the catalyst bed the hydrocarbons are cooled by direct spraying with oil, compressed, and sent to a vapour recovery system of conventional design where a cut of butadiene-butylene-butane is obtained. Butadiene is extracted and purified by solvent or a combination distillation-solvent extraction, and the remaining "B-B" cut returned to the process as recycle stock.

Isoprene is producible from wopentane, isopentenes or their mixtures.<sup>77</sup> Using the alumina-chromia catalyst at temperatures of 615-670°F. (1,139-1,220°F) and sub-atmospheric pressures of the order of 80 mm. of mercury absolute, overall recycle yields of 94-4% by weight of isoprene are obtainable from isopentane, 65-8% from a 50:50 mixture of isopentane and isopentene, and 97-1% from pure wopentene.

In one application of dehydrogenation processes ethylbenzene is converted to styrene, the hydrocarbon which is co-polymerised with butadiene to make synthetic rubber for tyres. Some processes use no catalyst and merely crack the ethylbenzene vapours to make moderate yields of styrene. In one commercial process the ethylbenzene vapours are cracked at 700°C. (1,320°F) at substantially atmospheric pressure. In another non-catalysed process, ethylbenzene vapours mixed with superheated steam are cracked to produce styrene at temperatures of the order of 760°C. (1,400°F) to obtain a yield

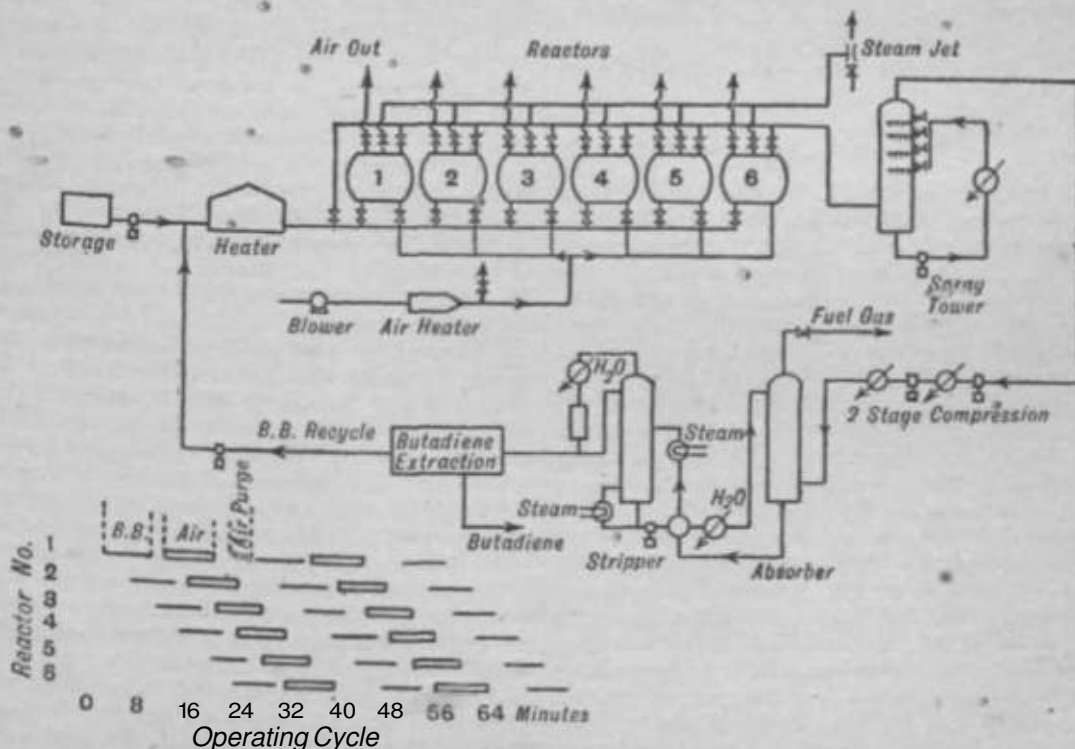

FIG. 30.

of about 55% based on the charge.<sup>78</sup> Another process uses 3 mol. of superheated steam per mol. of ethylbenzene, a temperature of 650°C. (1,200°r.)» and a magnesia-potassium oxide catalyst. When using alumina-chromia catalysts, temperatures of 600-700°o. (1,112-1,292°F.) and sub-atmospheric pressure, ultimate recycle conversions as high as 91% are obtainable commercially.

### Production of Aromatics by Dehydrocyclisation.

Dehydrogenation of hydrocarbons containing six or more carbon atoms in straight-chain arrangement under mild conditions of time, temperature, and catalyst activity can be used to produce mono-olefins and diolefins without much alteration of molecular structures in the direction of cyclisation. More severe conditions, including higher temperature, longer time, and more active catalysts result in formation of aromatic hydrocarbons by cyclisation reactions. Thus, substantial yields of hexenes and hexadienes, with small amounts of benzene, can be produced from n-hexane under certain conditions of operation, and major yields of benzene, under conditions of increased severity. At 550°o. (1,022°F.), using a catalyst consisting of 92% by weight alumina and 8% by weight chromic oxide, the recycle yields of toluene produced from n-heptane are shown in Table XXV.<sup>79</sup> The yield of the toluene went through a maximum of 79.5% weight of the theoretical at a liquid space velocity of 0.78. A maximum once-through yield of 72%-weight of the theoretical was obtained at a liquid space velocity of about 0.39.

TABLE XXV.—TOLUENE RECYCLE YIELDS.

Liquid space velocity (volume per volume* catalyst per hour)	0.034	0.195	0.385	0.78	500	1000
Toluene recycle yields, weight % of theoretical.	.65-7	72.7	78.8	79.5	62.2	600

Dehydrocyclisation of aliphatic hydrocarbons to produce aromatics is practised commercially in several processes. In the "cycloversion" process, naphthas from thermal cracking react with a catalyst at temperatures of 482-538°o. (900-1,000°\*), the naphtha vapours being mixed with steam to reduce the partial pressure of the hydrocarbons.<sup>80</sup> In the "hydro-forming" process, straight-run or cracked naphthas are vaporised and mixed with hydrogen before coming into contact with dehydrogenating catalyst." The hydrogen serves to lessen carbon deposits on the catalyst without unduly suppressing dehydrogenation reactions. When using selected fractions containing cyclohexane and methylcyclohexane, benzene and toluene result from the dehydrogenation of cycloparaffin rings. Aromatic hydrocarbons are recovered from the products of naphtha dehydrogenation processes by solvent extraction and subsequent fractionation of the extracted material.

Aromatics are also produced by the dehydrogenation and cyclisation of mono-olefins, di-

olefins or acetylenes, provided that in all cases there are six carbon atoms present in linear arrangement. -The same catalysts employed in the dehydrogenation of gaseous paraffins can be employed in the production of aromatics from these higher aliphatics.

### Toluene from Petroleum.

By using a fraction of petroleum boiling within the range 93-121°o. (200-250°F.), which has a high methylcyclohexane content and treating it with dehydrogenating catalyst in the presence of hydrogen (hydro-forming), a product containing 40-60% aromatics, of which 15-20% is toluene, is produced. The aromatics are separated by solvent extraction and accurately fractionated to produce toluene of high purity suitable for nitration\*

### ALKYLATION.

Synthetic processes are now in operation in the petroleum industry which involve the "addition of alkyl groups to aromatic, naphthenic, and paraffin hydrocarbons to produce product": having improved motor-fuel characteristics or special properties adapting them to other uses. In both cracking\* and treating certain alkylation reactions occur, but in mixtures of large numbers of hydrocarbons of varying structure and reactivity there is at present little possibility of separating and identifying the products. All alkylation reactions are exothermic and in practice provision must be made for disposing of the heat of reaction.

### Aromatics.

The oil industry has both olefins and aromatics as products\* of cracking and\* dehydrogenation, which can be used in the manufacture of alkylated aromatics.<sup>82</sup> This type of reaction has been established for some time and can be brought about without the use of catalysts at temperature\* of 400-600°o. (752-932°F.), under high pressures of the order of 1,000-2,000 psi. One of the important products of aromatic alkylation is ethylbenzene for dehydrogenation to styrene used in the manufacture of synthetic rubber. Another product of aromatic alkylation is isopropylbenzene (cumene), which is made by alkylating benzene with propylene either thermally or in the presence of a catalyst.<sup>83</sup> This compound has anti-knock properties considerably above that of the standard wocane and is used as a component of aviation-fuel blends. During the Second World War the British plants produced a high octane rating hydrocarbon mixture consisting principally of *see-* and *tert.*-butylbenzene which was called "Victane." Naphthalene is alkylated with liquid olefins obtained as a product of cracking paraffin wax to produce additives for lubricants which act as pour-point depressants.

The alkylation of aromatic hydrocarbons with olefins may employ several alternative catalysts among which are aluminium chloride and other chlorides of metals such as zirconium, tantalum, and zinc, and mineral acids such as sulphuric and phosphoric acids. Benzene may be alkylated with olefins in the presence of hydrogen fluoride.<sup>84</sup>

Commercial processes are in operation wherein benzene is alkylated with ethylene to make ethylbenzene, and with propylene to make *iso*-propylbenzene (cumene), using the Bolid phosphoric acid catalyst employed in the polymerisation of olefins in the gas mixtures from cracking, reforming, and dehydrogenation processes. In alkylating benzene with ethylenes in the presence of this type of catalyst, temperatures of 275-294°a (525-560V) and pressures of 600 psi. are employed, while more moderate conditions of 205°0. (400°F) and 400 psi. are used when alkylating with propylene.\*

*iso*Paraffins.

Reactions of still greater importance to the oil industry and related chemical industries involve the alkylation of isoparaffin hydrocarbons. Normal paraffins are much more difficult to alkylate than their isomers. Fray has reported the reaction of propane and *n*-butane with

ethylene and propylene under severe temperature and pressure conditions, and indicated the formations of small amounts of pentanes, hexanes, and heptanes.<sup>87</sup> V. N. Ipatieff and H. Fines, working in Universal Oil Products Company laboratories, were the first to alkylate paraffins with olefins catalytically. Early commercial processes involve the alkylation of *iso*-butane with normally gaseous olefins to produce liquid isoparaffin hydrocarbons having high anti-knock ratings. Both thermal and catalytic processes have been developed for this reaction, the thermal process requiring relatively high temperatures and pressures, while those employing various catalysts operate under less severe conditions. Processes for the alkylation of *iso*-butane have several advantages over methods for *iso*octane manufacture involving polymerisation of normal and *n*-butylenes and hydrogenation of the mixture of dimers. In contrast to polymerisation and hydrogenation, the alkylation process is single-stage. Based on the

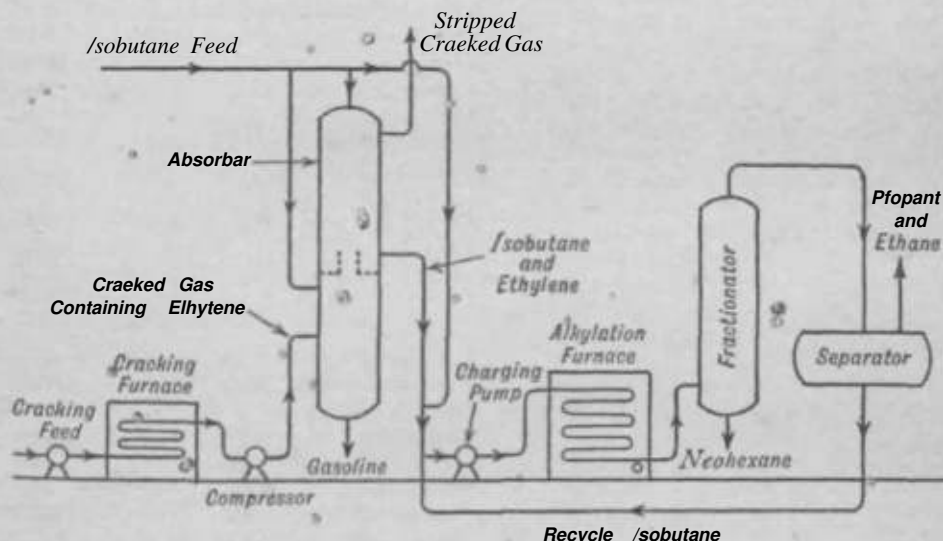

FIG. 31.

volume of liquid butylene employed, from 160-180% yield of alkylate consisting predominately of *iso*octanes is produced in commercial installations. In addition to alkylate, several per cent, of pentanes are produced. Alkylation with *n*-butylene gives a mixture of octanes having about 95 octane number, while alkylation with *iso*butylenes gives a product having from 88-100 octane number.

**Thermal Alkylation of *iso*Butane.**—When alkylating *iso*butane with olefins in the absence of catalysts, temperatures of the order of 500°0- (932°F.) and pressures ranging from 1,000-6,000 psi. are employed, pressure being necessary to minimise decomposition reactions to avoid polymerisation of the olefins, a large molal excess of the *n*-paraffin is maintained. In thermal alkylation, the products from *n*-butane and ethylene contain large amounts of neohexane, which has an octane number of 94 and a high susceptibility to improvement by the addition of toluene. Neohexane is used as an ingredient of aviation-fuel blends.

Fig. 31 shows the process flow in a plant designed for making neohexane from *n*-butane and ethylene by thermal alkylation.<sup>88</sup> A feed stock containing ethane, propane, and butane, obtained in the fractionation of natural gas, is cracked at temperatures of 700-815°0. (1,400-1,600°F) under pressures of from 5 to 36 psi. in a cracking furnace to produce a mixture containing considerable percentages of ethylene. The cracked gas mixture is introduced to an absorber in which a portion of the *n*-butane feed is used as an absorbing liquid, & solution of ethylene in *n*-butane being collected on a centrally disposed plate and a gasoline fraction being recovered from the bottom of the absorber. Cracked products lighter than ethylene comprising principally methane and hydrogen are released from the top of the absorber.

The *n*-butane-ethylene solution, with more *n*-butane added to furnish the necessary excess, is pumped through an alkylation furnace at a temperature of 500-525°0. (932-977°F.) under pressures of 3,000-5,000 psi. The products from

the alkylation zone are fractionated to recover neohexane, to separate propane and ethane, and to furnish unreacted wobutane for recycling.

Typical data on conditions of operation and products of thermal alkylation are given in Table XXVI. Column 1 shows that the alkylation of propane with ethylene produced 6.2% of ffopentane and 0.81% of branched chain hexanes. The alkylation of wobutane with

ethylene, according to column 2, gave 6.26% of 2:2-dimethylbutane and 2.6% of other hexanes, both normal and branched. The alkylation of tjobutane with wobutylene, according to the data in column 3, at 8,000 psi. and 486°c. (907°f.) gave about 1% of octanes and the same percentage of octenes, indicating polymerisation of Mowbutylene occurring along with the alkylation of the wobutane.

TABLE XXVI.—PRODUCTS FORMED FROM PARAFFIN-OLEFIN MIXTURES UNDER THERMAL CONDITIONS.\*

Reactants, %.	{ C <sub>3</sub> H <sub>6</sub> , 8.9 C <sub>4</sub> H <sub>8</sub> , 91.1	C <sub>3</sub> H <sub>6</sub> , 11.8 wo-C <sub>4</sub> H <sub>8</sub> , 88.2	wo-C <sub>4</sub> H <sub>8</sub> , 8.2 tw-C <sub>4</sub> H <sub>8</sub> , 91.8
Pressure (psi.)	4,500	4,500	P,000
Temperature °o. (°F.)	510 (950)	515 (9*9)	486 (907)
Gasoline yield based on total products	11.2	14.8	2.9
Analysis of products:			
C <sub>5</sub> H <sub>12</sub>	0.004	0.55	0.12
C <sub>6</sub> H <sub>14</sub>	0.716	1.72	0.05
C <sub>7</sub> H <sub>16</sub>	1.23	0.71	0.04
C <sub>8</sub> H <sub>18</sub>	0.53	0.60	0.19
C <sub>9</sub> H <sub>20</sub>	0.16	0.76	0.05
C <sub>10</sub> H <sub>22</sub>	84.40	0.76	0.05
MO-C <sub>4</sub> H <sub>8</sub>	0.71	2.04	4.10
n-C <sub>4</sub> H <sub>10</sub>	0.80	78.77	92.36
Scff	0.70	0.29	0.20
C <sub>7</sub> H <sub>14</sub>	0.29	0.73	0.11
C <sub>8</sub> H <sub>16</sub>	6.20	0.77	0.05
C <sub>9</sub> H <sub>18</sub>	1.82	6.26	
C <sub>10</sub> H <sub>20</sub>	0.22		
2:2-Dimethylbutane	0.81	2.60	0.08
2:3-Dimethylbutane			
2-Methylpentane			
n-Hexane			
C <sub>7</sub> H <sub>14</sub>	0.20	0.26	0.10
C <sub>8</sub> H <sub>16</sub>	1.12	0.61	1.13
C <sub>9</sub> H <sub>18</sub>	0.12	0.47	1.01
C <sub>10</sub> H <sub>20</sub>	0.37	1.80	1.05
C <sub>11</sub> H <sub>22</sub>		0.72	
C <sub>12</sub> H <sub>24</sub>		0.15	
C <sub>13</sub> H <sub>26</sub>			
C <sub>14</sub> H <sub>28</sub>			
C <sub>15</sub> H <sub>30</sub>			
C <sub>16</sub> H <sub>32</sub>			
C <sub>17</sub> H <sub>34</sub>			
C <sub>18</sub> H <sub>36</sub>			
C <sub>19</sub> H <sub>38</sub>			
C <sub>20</sub> H <sub>40</sub>			
C <sub>B+</sub> to 200°c. (392°F.)	0.10		0.36
Above 392°F.			
Total	100.00	100.00	100.00

Composition of Liquid Products.			
Analysis of liquid products:			
C <sub>5</sub> H <sub>12</sub>	2.6	1.9	6.5
MO-C <sub>4</sub> H <sub>8</sub>	55.1	5.0	3.6
n-C <sub>4</sub> H <sub>10</sub>	16.2	5.2	1.6
C <sub>7</sub> H <sub>14</sub>	1.9	42.1	
2:2-Dimethylbutane	7.1	17.5	2.6
2:3-Dimethylbutane			
2-Methylpentane			
n-Hexane			
C <sub>7</sub> H <sub>14</sub>	1.8	2.4	3.2
C <sub>8</sub> H <sub>16</sub>	10.0	4.1	4.2
C <sub>9</sub> H <sub>18</sub>	1.0	3.2	32.7
C <sub>10</sub> H <sub>20</sub>	3.3	13.7	34.0
C <sub>B+</sub> to 200°c. (392°F.)	1.0	4.8	11.6
Heavier		1.1	
Total	100.0	100.0	100.0

\* All percentages are by weight.

*Catalytic Alkylation of isoButane.*

1. *Sulphuric Acid.*—isoButane is alkylated with butylenes in the presence of sulphuric acid of 90-100% concentration. Low temperatures of about 0-10°o. (32-60°F.) are used to reduce the oxidising tendencies of the acid, which buffers some losses even under these conditions, because of the formation of addition compounds with the olefin and hydrocarbon oxidation products. About 1 lb. of acid is required for producing 1 gallon of alkylate. Yields of alkylate from 140 to 180% by volume of butylenes are obtained.

Fig. 32 shows the process flow in a plant (for alkylating isobutane with butylenes using sulphuric acid catalyst.<sup>80</sup> The charge to the plant may be a mixture of t'sobutane and butylene from a thermal reforming, thermal cracking or catalytic cracking plant, or a plant in which normal butane IB catalytically dehydrogenated. isoButane is added so that it is in considerable molar excess over the butylenes during alkyla-

tion. It is customary to maintain a ratio of 4-6 mol. of iso butane to 1 mol. of olefin in the reaction zone. Higher octane number products result when higher ratios are maintained. Best results are also dependent upon the use of large volumes of sulphuric acid in proportion to the hydrocarbon mixture. The required amount of isoButane may be produced by isomerising n-butane, or may be shipped in from other refineries or natural gasoline plants. The acid and hydrocarbons are thoroughly mixed in the reactor to form an emulsion. The mixture is passed to a settler from which a certain amount of spent or waste acid is withdrawn, and the balance recycled among with make-up acid to counteract the IOSB. A rapid circulation between the settler and the reactor assists in producing intimate contact between the catalyst and the hydrocarbon. The hydrocarbon layer from the settler is passed to a fractionator from which isoButane is separated and returned to the

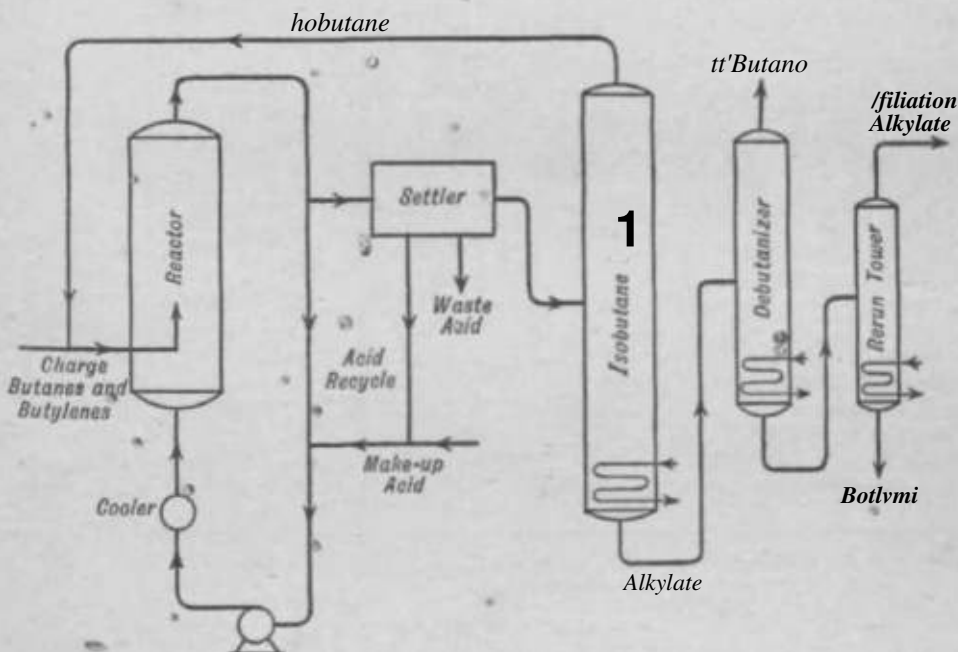

Fro. 32.

reactor along with fresh charge. After removal of the isoButane, the alkylate passes to a debutanizer to recover n-butane. The aviation alkylate fraction is finally recovered from a re-run tower from which high boiling alkylated products are withdrawn as bottoms.

Commercial data on alkylation of olefins with sulphuric acid catalysts are given in Table XXVII. The olefins employed were: (1) a propylene-butylene fraction from cracking; (2) a butane-butylene fraction from a cracking process; and (3) a residual butane-butylene fraction from the polymerisation of a mixture of butanes and butylenes to make octene dimer for hydrogenation to octane. The olefins in this first alkylating mixture were mainly n-butylenes. Yields of from 138 to 180% of total alkylate based on the volume of the olefin used were obtained. A temperature of 29°o. (85°F.) was used in the first alkylation with propylene, and

temperatures of 0-10°o. (32-50°F.) were maintained when alkylating with t-butylenes in the second and third runs. The highest octane number products and the highest yields were obtained with the butane-butylene fractions.

2. *Hydrogen Fluoride.*<sup>81</sup>—Another catalyst which is employed in alkylating isoButane with butylenes is liquid hydrogen fluoride. Since this compound boils at 20°o. (68°F.) under ordinary pressures, it can be used as a liquid at ordinary temperatures under slight super-atmospheric pressure. It has no oxidising effects on hydrocarbons, and the small amount of addition compounds it forms with olefins are readily decomposed by moderate heating so that the hydrogen fluoride can be recovered and used.

Fig. 33 shows the essential features in a plant using hydrogen fluoride for catalysing the alkylation of isoButane with butylenes. The charge is similar to that used when employing sulphuric

TABLE XXVII.—ALKYLATION OF WOBUTANE WITH REPRESENTATIVE REFINERY O^EWN FEED STOCKS.

	1.	2.	3.
	C <sub>3</sub> fraction from cranking.	C <sub>4</sub> fraction from cranking.	Residual C <sub>4</sub> fraction from feocctane manufacture.
Olefin feed stock (% by weight of olefin).	30 (a)	48(6)	24 (c)
woParaffin used.	<i>isobutane</i>	<i>isobut&amp;ne</i>	<i>tsobutane</i>
Mol. ratio of woparaffin to olefin .	8	5	5
Make-up acid strength, % by weight of sulphuric acid.	98-100	98-100	98-100
Volume ratio of acid to hydrocarbon	1	1	1
Temperature.	29° a; 85°F.	0-10° c.; 32-50°F.	0-10° c.; 32-50°F.
Contact time, minutes.	20-40	20-40	20-40
% by volume of total alkylate based on olefin in feed.	138	158-136	168-180
Aviation fraction (end point, 149° c.; 300° F.) in total alkylate, %	92-95	88-90	89-91
<i>Properties of Products.</i>			
Properties of total alkylate (C <sub>4</sub> -free):			
Sp.gr. . . . .	0-6950	0-7050	0-7050
A.P.I.gr. . . . .	721	69-2	69-2
Octane No. (A.S.T.M.-C.F.R.) . .	880 "	91-5	92-5
A.S.T.M. distillation:			
Initial b.p.	°C. 67 °F. 152	°C. 49 °F. 120	°C. 47 °F. 117
10% point . . . . .	82 180	83 182	84 183
50% point . . . . .	90 194	106 222	107 225
90% point . . . . .	133 271	131 267	121 250
End point . . . . .	197 387	206 403	192 378
Properties of 149° c. (300° F.) end-point fraction:			
Octane No. (A.S.T.M.-C.F.R.) . .	89	92	93
50% point . . . . .	88 190	104 220	105 221
Reid vapour pressure, psi. . . .	—	3-5	30

(a) With mixed C<sub>3</sub> and C<sub>4</sub> fractions, materially better results are obtained.  
 (b) About 18% w-butylene present.  
 Largely n-butylene.

acid catalyst, and is mixed with liquid hydrogen fluoride in a reactor under about 100 psi. at a temperature of 38° c. (100° F.). The products are passed to a settler from which apportion of the mixture of hydrogen fluoride and hydrocarbon is recirculated to the reactor, and another portion is passed to a recovery system wherein alkyl fluoride products are heated to recover the hydrogen fluoride and olefin. The hydrocarbon layer from the settler is passed to a fractionator to separate hydrogen fluoride for re-use in the process. The hydrocarbons from the fractionator are passed to a dewobutaniser from which *isobut&ne* is distilled and recycled to the reactor. Tower bottoms are passed through a solid absorbent in a treater to remove traces of fluoride. w-Butane is next removed and the alkylate is distilled to produce aviation alkylate.

3. *Aluminium Chloride.*—Alkylation of *isobutane* with ethylene in the presence of aluminium chloride-hydrogen chloride catalyst produces an alkylate which contains as a major component 2:3-dimethylbutane in contrast to

the 2:2-compound, or wohexane, produced in thermal alkylation" The use of aluminium chloride as a catalyst in the alkylation of wobutane with olefins requires considerable excess of catalyst. Lower temperatures around 0° c. (32° F.) to lessen the tendency toward polymerisation of the olefins and the formation of compounds with the aluminium chloride.

It is necessary to the catalytic activity of aluminium chloride to have minor amounts (less than 10 mol.%) of hydrogen chloride present. Perfectly dry aluminium chloride in the absence of hydrogen chloride has low catalytic activity in alkylation reactions, small amounts of moisture may generate enough hydrogen chloride to improve the catalytic action.

Other hydrogen chloride catalysts which can be used in the alkylation of woparaffins include aluminium bromide in the presence of hydrogen bromide, boron fluoride, or mixtures of this compound and hydrogen fluoride.



Alkylation of isopentane or isohexane can be accomplished in the presence of catalysts used for alkylating isobutane. The conditions of operation will vary with the molecular weight and structure of both isoparaffins and olefins.

All isoparaffin alkylations are accompanied by varying amounts of side reactions leading to the formation of lower and higher molecular weight paraffins. The catalysed processes are more selective and produce smaller amounts of by-products.

ISOMERISATION.

Isomerisation of the hydrocarbons in petroleum gases and gasoline is practised for the purpose of producing hydrocarbons of branched structure which are more reactive in syntheses, or have intrinsically higher octane ratings due to their more condensed molecular structure.\*<sup>3</sup> The structures and octane ratings of paraffin hydrocarbons having from 4 to 7 carbon atoms

in the molecule are given in Table XLVI. The data confirm in all cases the beneficial effect of branched structure on knock ratings. Although the rules applicable to such relationships in other hydrocarbon groups are more complicated, the general rule that higher octane rating accompanies more condensed structure has few exceptions.

In processes of commercial significance a catalyst is employed to speed up paraffin isomerisation rates, aluminium chloride being chiefly employed. Other types of catalysts have been tried for paraffin isomerisations, but none are competitive with aluminium chloride.<sup>4</sup> Aluminium bromide is an effective catalyst but is expensive, and zinc chloride and boron fluoride have lower activity. The same catalysts that isomerise paraffins will usually isomerise cycloparaffins. Thus cyclohexane is isomerised to methylcyclopentane. In the isomerisation of olefins, less active catalysts such as aluminium

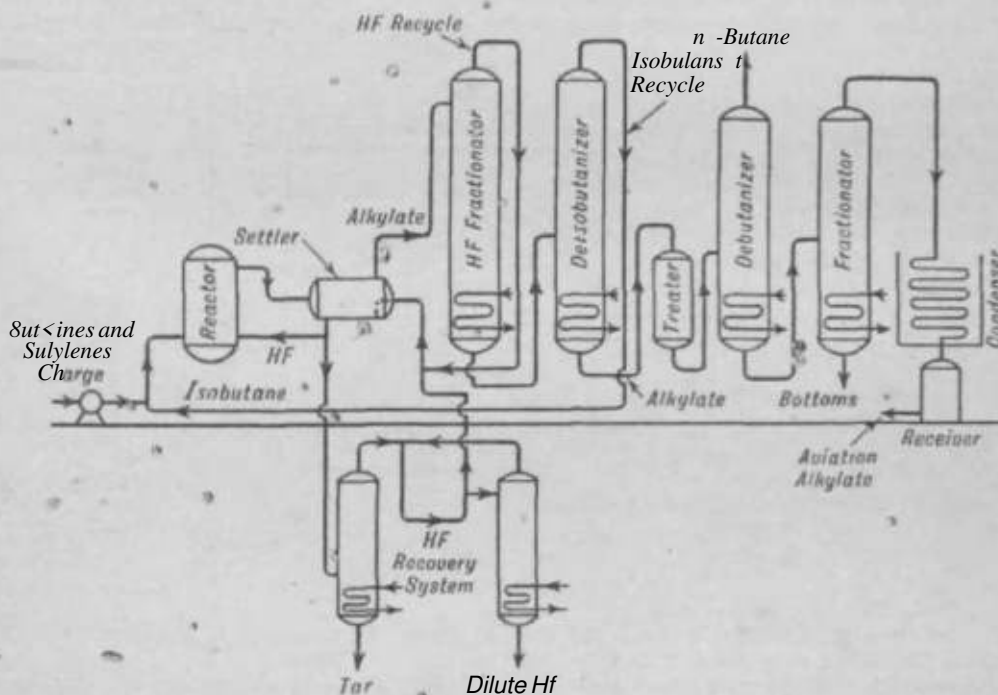

Fig. 8S.

sulphate and aluminium oxide are used because they have less tendency to polymerise olefins.

Isomerisation of n-butane to isobutane is one of the important processes employed in the oil industry. The ratio of n- to isobutane is always greater than unity in hydrocarbon gas mixtures encountered in natural gas, gases from the straight-run distillation of petroleum, or from non-catalytic cracking of its fractions. In the gas produced in catalytic cracking for gasoline, the butanes usually contain more isobutane than n-butane. Isobutane is readily alkylatable by gaseous olefins so that isoparaffins from hexanes to dodecanes can be produced, and thus by the conversion of n-butane to isobutane the potential supplies of high anti-knock hydrocarbons are increased. n-Butane is readily isomerised at relatively low temperatures by aluminium chloride in the presence of hydrogen chloride.

In commercial practice aluminium chloride is used on a supporting material such as prepared alumina, the composite catalyst being placed in a reactor through which preheated n-butane and hydrogen chloride are passed. In another type of operation, liquid butane is passed through a bed of granular aluminium chloride from which it dissolves a certain amount of the salt below an isomerising temperature. The solution is then passed into a reactor at a high temperature to produce isobutane. A flow diagram of such a plant for isomerising n-butane is shown in Fig. 34.\*<sup>5</sup> Fresh and recycle n-butane is pumped through a heater under a pressure of about 300 psi. and the temperature is raised to about 50°C. (1176°F.). Under these conditions the butane is liquid and it is passed in part through an aluminium chloride extractor in which it dissolves catalyst for effecting its conversion in the



succeeding reactor, which may be filled with inert granular packing material. Hydrogen chloride is introduced to the reactor to assist in catalysing the isomerisation.

From the bottom of the reactor a sludge consisting of addition products of aluminium chloride and hydrocarbons is drawn. The hydrocarbons from the reactor are passed to an aluminium chloride fractionator from which butanes are distilled, and aluminium chloride concentrate is pumped back into the top of the reactor. The butanes are condensed and then passed to a hydrogen chloride fractionator, the hydrogen chloride being returned to the reactor. The mixture of *n*- and isobutane is washed with caustic soda and fractionated into isobutane which is recovered as the product of the process, and *n*-butane which is recycled for isomerisation. By the operation described, 50% conversion of *n*-butane to isobutane may be brought about in a single pass through the apparatus. With recycling of separated unconverted *n*-butane, the ultimate yield of the isoparaffin may be brought to about 90%.

As the molecular weights of the paraffin hydrocarbons increase there is more and more tendency for decomposition rather than simple isomerisation reactions to occur. A minimum temperature is essential, and lower conversions per pass and greater recycle ratios are required. In some processes inhibitors are used to reduce the decomposition reactions. Added hydrogen may be effective for this purpose. The activity of the aluminium chloride catalyst is also modified by utilising its liquid hydrocarbon addition complexes rather than the salt itself. By using all of these expedients, the isomerisation of *n*-pentane and *n*-hexane has been commercialised. The octane rating of *n*-pentane is 64, whilst that of isopentane is 91. Similar increases in octane rating are obtained when *n*-hexane is isomerised.

Although equilibrium considerations indicate that low temperatures favour more highly branched paraffin isomers, isomerisation rates of normal paraffins are so low at low temperatures that highly branched products are not formed in appreciable amounts. When *n*-heptane is treated with aluminium chloride-hydrogen chlo-

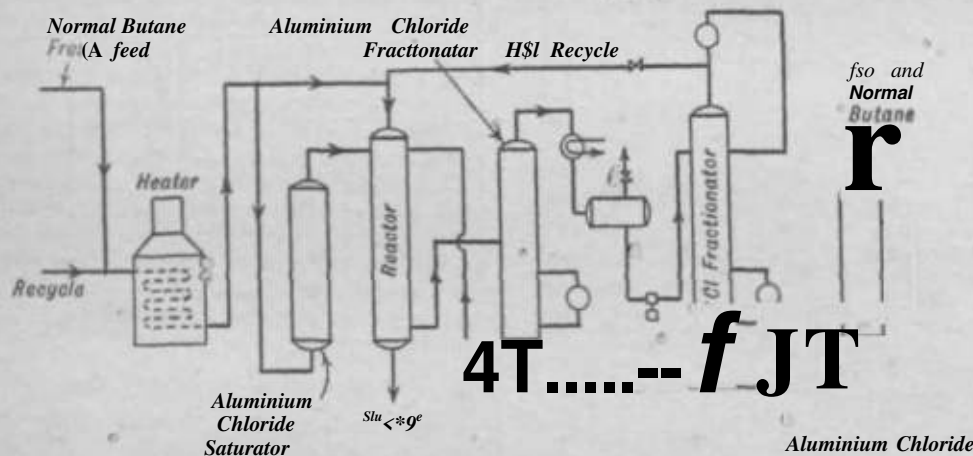

FIG. 34.

ride catalyst at a temperature corresponding to a substantial degree of conversion, the principal isomers are monoisobutanes and dimethylpentanes. There is no appreciable formation of 2:2:3-trimethylbutane."

Aluminium halide catalysts are also effective in isomerising *eg* isoparaffins, either pure or contained in petroleum fractions. Thus isobutylcyclohexane is obtained when isobutane is heated in the presence of aluminium chloride at ordinary atmospheric pressure. The overall effect of aluminium chloride on fractions of petroleum containing paraffins and cycloparaffins will be determined by the proportions of these groups, the amount of aluminium chloride, and the temperature employed. In cracking petroleum fractions with aluminium chloride catalyst, isomerisation as well as decomposition reactions occur, and considerable amounts of isobutane are found in the gaseous by-products.

There is evidence to support the fact that the catalysts in aluminium chloride isomerisations have either the formula  $HA\cdot Cl_4$ , or  $Al(OH)\cdot Cl_3$ ,<sup>M</sup> these compounds being formed

by the direct addition of hydrogen chloride or the action of water.

*i*-Butylene and 2-butylene obtainable from cracked gas mixtures by fractionation can be isomerised to isobutylene by several catalysts such as, for example, alumina, alumina containing a trace of sulphuric acid, anhydrous aluminium sulphate, fuller's earth, phosphoric acid on charcoal, or silicates.\*\* In all reactions involving isomerisation of olefins, the tendency to polymerisation is strongly competitive.

#### HYDROGENATION

Hydrogenation and destructive hydrogenation of hydrocarbons are employed in the refining of petroleum to increase yields and improve the properties of various products.<sup>100-101</sup> Any decomposition of petroleum fractions involves essentially a carbon-hydrogen equilibrium, and addition of hydrogen alters the balance and gives rise to a number of new products. Hydrogenation is one of the important processes in use at present, and will become one of the most important in the conservation of petroleum.

Hydrogenation of Unsaturation.

The simplest application of hydrogenation is in the direct addition of hydrogen to hydrocarbons having aliphatic or cyclic double bond linkages. The saturation of mono-olefins with hydrogen is readily brought about under mild conditions. The *iso-Octeyla* dimers from butylene polymerisation processes, and mixed polymers from the copolymerisation of propylene and butylene, are hydrogenated in the presence of active nickel catalysts at temperatures of the order of 100°C. (320°F.) and pressure of 75 psi. to produce woparaffins having octane ratings from 90 to 100, which are used as components of aviation-fuel blends.<sup>13</sup> The properties of *iso*-octanes produced by hydrogenating woctene dimers from the polymerisation of butylenes from cracked gases are shown in Table XXVIII. Mild hydrogenation of lubricating oils improves their viscosity indices by increasing their paramnicities. This process has found commercial application in at least one plant because of the greater values inherent in hydrogenated lubricating oils. The increased amount of naphthene and paraffin hydrocarbons is responsible for a lessened tendency to lose viscosity on heating.

TABLE XXVIII.—PROPERTIES OF *iso*-OCTANES.

Sp. gr.	0.7150
A.P.R. gr.	68.4
100 c.c. distillation (A.S.T.M.):	"C." "P.
Initial Up	90 210
% Distilled over:	
10	100 222
50	108 227
90	111 282
End b. p.	123 254
Octane No. (A.S.T.M. motor method)	1150
Reid vapour pressure; psf.	1.6
Viscosity (%)	0.6
Gum (copper dish)	0
Colour, Saybolt	30

The hydrocarbons chiefly responsible for gum formation in cracked gasolines are diolefins in character and present in relatively small amounts. Such compounds are readily hydrogenated under moderate conditions of temperature, pressure, and catalyst activity. Cracked gasolines containing undesirably large amounts of sulphur can be desulphurised by hydrogenation at temperatures about 350°C. (662°F.), under pressures of about 900 psi. in the presence of "sulphactive" catalysts which include the single and mixed sulphides of nickel, chromium, and molybdenum. The catalysts are used in reactors through which preheated mixtures of gasoline vapours and a moderate excess of hydrogen (about 4 mol. per mol. of gasoline) are passed. The use of these sulphide catalysts, particularly nickel sulphide, reduces the amount of hydrogenation of mono-olefins and aromatics, and hence loss in anti-knock value. Owing to the removal of diolefins and reduction in sulphur content, the susceptibility to improvement in octane number by the addition of tetraethyl-lead is increased, and leaded gasolines of higher octane number than the original gasoline are produced. Using this method of treatment, a Californian cracked gasoline was reduced in sulphur content from 1.17 to 0.05%, with a reduction in octane

number from 72 to 69. However, the addition of 3 ml. of tetraethyl-lead per gallon only produced an octane number of 77 in the untreated product, whereas the same lead addition produced an 81 octane number gasoline in the treated product.<sup>103</sup>

Hydrogenation of aromatic hydrocarbons present in cracked fractions results primarily in de-alkylation of alkyl aromatics, and saturation of the rings, to compounds of a cycloparaffinic character. Under conditions of greater severity, ring breaking occurs and paraffin hydrocarbons are formed. An important application of hydrogenation is in the saturation of highly aromatic recycle intermediates in cracking. The hydrogenated oils respond to further cracking with lessened tendencies for carbon deposition and increased yields of gasoline.

The use of intensive hydrogenating conditions permits the extensive purification of petroleum fractions. All sulphur compounds, including alkyl sulphides, dialkyl disulphides (from sweetening reactions), mercaptans, and heterocyclic compounds such as thiophenes and thio-phenans are reducible to hydrocarbons and hydrogen sulphide, which is readily separated from the products of hydrogenation. Oxygen compounds, including naphthenic acids and phenols, are also susceptible to the action of hydrogen under catalytic influence, yielding water and hydrocarbons without alteration of carbon atom arrangements.<sup>111</sup> Nitrogen compounds represented by alkyl-quinolines and *iso*-quinolines in straight-run products, and alkylamines, the presence of which has been noted in some cracked products, can be made to yield ammonia and saturated hydrocarbons.

Destructive Hydrogenation.

Added hydrogen in cracking exerts many beneficial effects. The tendency to carbon deposition is practically nullified, since coke formation in cracking is due to the ultimate breakdown of polycyclic aromatics with liberation of hydrogen which combines with the lighter product\*. When added hydrogen, activated by catalyst, is present in the cracking zone, this aromatic decomposition is suppressed, and the hydrogen reacts to produce higher boiling naphthenes which are fluids utilizable as lubricants in many instances. In hydrocracking, yields of light distillate\* over 100% by volume of the charge are obtained. The character of the gasoline can be controlled so that it is completely saturated and consists of mixtures of isoparaffins and aromatic hydrocarbons. Hydrocracking can be applied to straight-run and cracked residuums, asphalts, and heavy petroleum products such as tars from tar sands to produce motor fuel.

The usual conditions for destructive hydrogenation are temperatures of 400-500°C. (752-932°F.), and pressures of 200-300 atmospheres. The preheated oil and hydrogen are forced through beds of catalyst, and hydrogen is separated from the reaction products and recycled.<sup>106</sup>

While a large variety of catalytic materials have been proposed for use in hydrogenating petroleum, relatively few have stood the test

of service. Nickel and its oxides and sulphides, and the oxides of chromium, molybdenum, and tungsten are used. These catalysts are employed on supports such as alumina, silica, magnesia, and silicates. The catalysts employed commercially are those of a "sulphactive" type, meaning that their sulphides have adequate catalytic activity. Molybdenic sulphide is most commonly used, while its activity is not as high as molybdenic oxide, it has a constant value over long operating periods.

The major possible adaptations of hydrogenation to petroleum refining have been listed as follows:

1. The production of gasoline low in sulphur, and distillates free from asphalt, from heavy high-sulphur asphaltic crude and

refinery residues, without coke formation.

2. The production of lubricating oils having high viscosity indices, low carbon residues, and high flash points from low-grade lubricating distillates.
3. Improvement of poor-burning kerosene distillates by conversion to low-sulphur water-white burning oils.
4. The desulphurisation and colour and gum-stabilisation of cracked naphthas with minimum change in distillation range and minimum loss in anti-knock value.
5. The production of high octane rating, low-sulphur stable gasolines from gas oils.

Table XXIX shows approximate yields in these five types of processes.

TABLE XXIX.

Process No.	Charging stock.	Approximate volumetric yield of:				Total volumetric yield.	Sulphur in charge removed in process.	Gas formation.
		Gasoline.	Burning oil.	Gas oil.	Lubricating oil.			
		% by wt.	% by wt.	% by wt.	% by wt.	% by wt.	% by wt.	
1	High-sulphur, asphaltic heavy residue.	30	—	71	—	101	65-85	2-3
2	Low-grade lubricating distillate	10	—	29	65	104	80-95	0.5-1.3
3	Low-grade burning oil distillate	30	73	—	—	103	80-95	0.5-2
4	Cracked naphtha	100	—	—	—	100	50-95	0.5
5	Paraffinic gas oil	65-100	—	—	—	70-100	80-95	5-35

By varying the conditions of operation in respect to temperature, pressure, catalyst, and ratio of hydrogen to oil, a charging stock such as a kerosene, gas oil or residual fuel oil can be converted either into an improved product or into gasoline of an aromatic character having a high octane rating. For hydro-cracking to produce such gasoline, temperatures are raised and the ratio of hydrogen to oil is decreased.

Typical results obtained in hydro-cracking gas oils for gasoline production are shown in Table XXX.<sup>101</sup> The high yields of gasoline obtained by this process are noteworthy, and also the high octane numbers and low sulphur contents.

TABLE XXX.—HYDRO-CRACKING OF GAS OILS FOR GASOLINE.

Feedstock.	Mid-Continent.	Californian cracked.
Sp. gr.	0.8358	0.9001
A.P.I. gr.	37.8	25.7
Initial b.p.	224° C.; 435° F.	172° C.; 324° F.
Final b.p.	332° C.; 829° F.	317° C.; 602° F.
% distilled at 230° C. (450° F.)	3.5	3.10
Sulphur, wt. %	0.179	0.554
Hydrogenated product:		
Vol. % yield	86.5	8.90
Sp. gr.	0.7531	0.8076
A.P.I. gr.	56.4	43.7
Initial b.p.*	30° C.; 86° F.	41° C.; 105° F.
End b.p.	223° C.; 433° F.	214° C.; 417° F.
Octane No., A.S.T.M.	75.1	9.40
Sulphur, wt. %	0.022	0.017

In comparison<sup>11</sup> with cracking, hydro-cracking produces higher yields of gasoline and higher throughputs. The octane numbers of gasolines from hydro-cracking are lower than those from thermal cracking, but their response in increased octane rating by the addition of tetraethyl-lead is higher. Table XXXI contains data comparing cracking with high and low temperature hydro-cracking for five charging stocks.<sup>106</sup> The yield of gasoline in low temperature hydro-cracking is about double that obtained in thermal cracking. The daily production of gasoline in a 5,000 barrels per day total feed hydro-cracking plant is 60-80% greater than the gasoline from a 15,000 barrel per day total feed thermal cracking plant, as indicated by the data in Table XXXI. Octane ratings of the gasoline from hydro-cracking are from 11 to 15 numbers lower.<sup>107</sup>

The hydro-cracking process is also operated to produce aviation naphtha from selected gas oils. Conversions per pass of 50-75% and ultimate recycle yields of 80-95% are obtained. The inspection of several feed stocks subjected to high-pressure cracking and the properties of the aviation fuels are shown in Table XXXII.<sup>108</sup>

The hydrogen requirements for the various hydrogenating treatments of petroleum are a considerable item of expense. In some processes which have, however, met with little commercial success, hydrogen is generated in the reaction zone by the interaction of steam and metals, particularly iron, the iron oxide being removed and reduced to furnish more metal.<sup>109</sup>

TABLE XXXI.—COMPARISON OF HYDROGENATION \* AND CRACKING f RESULTS.

Charge.	Mixed cracking stock.			Coastal cycle gVs oil.			Heavy naphtha bottoms from mixed crudes.			Mid-Continent gas oil (light).			Mid-Continent gas oil.		
	Crack- ing.	High temp. hydro- genation.	Low temp. hydro- genation.	Crack- ing.	High temp. hydro- genation.	Low temp. hydro- genation.	Crack- ing.	High temp. hydro- genation.	Low temp. hydro- genation.	Crack- ing.	High temp. hydro- genation.	Low temp. hydro- genation.	Crack- ing.	High temp. hydro- genation.	Low temp. hydro- genation.
Sp.gr. . . . .	0.8849			0.8984			0.8718			0.8217			0.8581		
A.P.I. gr. . . . .	28.4			26.0			30.8			40.7			33.4		
50% at . . . . .	234°C. 453°F.			291°C. 556°F.			231°C 447°F.			227°C. 440°F.			282°C. 540°F.		
% at 204°C. (400°F.) . . . . .	200			—			22.7			16.0			—		
Endb.p. . . . .	380°C. 680°F.			—			—			326°C. 618°F.			—		
<b>OPERATING RESULTS :</b>															
Total throughput:															
Hydro, vol. per vol. per hr. . . . .	—	40	2.2	—	40	2.2	—	40	2.2	—	40	2.2	—	40	2.2
Cracking, barrels per day . . . . .	15,000	460	720	15,000	460	720	15,000	HMD	74.0	15,000	760	81.0	15,000	55.0	74.0
Vol. % fresh feed . . . . .	31.6	460	720	38.0	4*0	670	320	HMD	74.0	43.5	760	81.0	350	55.0	74.0
Vol. % tar (S.G. 0.9861; 12 A.F.I.) on fresh feed (cracking)	420	nil.	nil.	49.5	nil.	nil.	38.5	nil.	nil.	150	nil.	nil.	29.5	nil.	nil.
Gasoline (216°C.; 420°F.), end pt.:															
Vol. % raw gasoline on fresh feed . . . . .	505	930	1100	440	920	1100	54.5	91.0	1090	72.5	890	1080	61.5	910	1090
Vol. % finished gasoline on fresh feed . . . . .	470	89.5	109.5	41.0	88.5	109.5	50.5	87.5	108.5	67.5	85.5	107.5	570	87.5	108.5
Octane No. of finished gasoline X. . . . .	78.5	1740	640	722	67.0	580	75.5	69.0	600	68.2	640	570	69.6	630	540
Gasoline production, barrels per day:															
(a) In a 5,000 barrels per day total feed hydro plant.	—	2,060	3,940	—	1,860	3,470	—	2,580	4,130	—	32,50	4,350	—	2,400	3,800
(b) In a 15,000 barrels per day total feed cracking coil.	2,220	—	—	2,330	—	—	2,420	—	—	4,390	—	—	2,980	—	—

\* Eecyde operation wherein the feed stock is totally converted to gasoline and a small amount of gas.

t Recycle operation to ultimate yield of gasoline and 12 A.P.I. tar.

t Octane numbers obtained on Series 30 motor at 100°C. (212°F.) and 600 r.p.m.

PETROLEUM.

TABLE XXXII.—HYDROGENATED AVIATION NAPHTHAS FROM FOUR FEED STOCKS.

	Heavy naphtha from Mirando (Texas) crude.	Mirando, cracked cycle stock.	Kerosene fraction from Coastal crude.	Gas oil from Venezuelan crude.
Feed stock:				
Sp.gr. . . . .	0-8483	0-8838	0-9264	0-8708
A.P.I, gr. . . . .	35-3	28-6	21-4	31-0
Aniline point . . . . .	47°c.; 117°F.	32°c.; 90°F.	77°c.; 170°F.	54°c.; 129°F.
Sulphur, % . . . . .	0-050	0070	0-460	0-20
	°C. °F.	°C. °F.	°C. °F.	°C. °F.
Initial b.p. . . . .	104 220	153 308	193 379	173 343
10% at. . . . .	173 344	207 405	221 430	206 402
50% at. . . . .	209 408	229 445	238 460	247 477
90% at. . . . .	238 460	255 491	264 507	296 564
Final b.p. . . . .	268 514	277 531	290 554	321 614
Hydrogenated aviation fuel:				
Sp.gr. . . . .	0-7205	0-7347	0-7412	0-7139
A.P.I, gr. . . . .	64-9	61-1	59-4	66-7
Colour, Saybolt . . . . .	+30	+30	+30	+30
Sulphur, % . . . . .	0011	0002	0002	001
Reid V.P. 38°o. (100°r.), psi. . . . .	7-0	6-9	7-0	6-7
A.S.T.M.-C.F.R. octane No. . . . .	78-3	76-4	78-0	75-8

Hydrogen is readily produced from methane and steam in two stages. In the first, 1 mol. of methane and 1 of steam interact in the presence of catalyst at about 870°o. (1,600°F.) at atmospheric pressure according to the following equation:  $\text{CH}_4 + \text{H}_2\text{O} \rightarrow \text{CO} + 3\text{H}_2$ . Additional steam is added to the gases from the first stage and the carbon monoxide and steam interact in the presence of a different catalyst at a temperature of 454°o. (850°F.) to yield another mol. of hydrogen, according to the following equation:  $\text{CO} + \text{H}_2\text{O} \rightarrow \text{CO}_2 + \text{H}_2$ . Thus from 1 mol. of methane a total of 4 mol. of hydrogen is produced. Hydrogen is also available from dehydrogenation and dehydrocyclisation processes in very pure form, usually over 95%. High temperature cracking processes yield large amounts of hydrogen recoverable by fractionation of gas mixtures. Hydrogen in hydroforming processes controls the character of the reaction and limits the amount of carbon deposition. The use of added hydrogen in the isomerisation of pentanes and hexanes reduces decomposition reactions and renders the conversions more efficient.

#### TREATING.

Some crude oils, usually those of a paraffinic type, yield various distillate and residual products which are marketable without extensive changes, since they contain low contents of sulphur, oxygen, or nitrogen compounds, and practically no asphaltic components. The colour of gasoline and kerosene from such crudes is frequently water-white and their odours are not unpleasant. The lubricating fractions possess green or amber colour, along with an attractive fluorescence so that they can be sold and utilised with little treatment.

The majority of crude oils, however, contain sufficient amounts of sulphur in various forms of

combination to impart undesirable characteristics such as offensive odours and corrosion tendencies to their fractions, so that the removal of at least a portion of their sulphur content is desirable. The distillates from asphaltic crudes contain coloured compounds in colloidal suspension, which are undesirable, and these must be removed before they are saleable. Such asphaltic crudes yield motor fuel and lubricating distillates which require extensive treatment.

The commercial development of the cracking process has introduced new problems in treating, since the cracked distillates contain much higher percentages of olefins than straight-run distillates and appreciable amounts of diolefins, which are unstable in contact with air and light, and form colour and gums in the oils during periods of storage. The amount of sulphur in cracked gasolines is higher than in straight-run gasolines from the same crudes, and the sulphur compounds are of a different character and require different means for their treatment. Sulphur compounds in straight-run gasolines are less odorous, while those in untreated cracked gasolines impart the unpleasant odours of hydrogen sulphide and mercaptans.

#### Treatment with Sulphuric Acid.

The oldest and most generally employed method of treating petroleum products to improve their properties involves the use of sulphuric acid of varying concentration. To accomplish different objectives, acids of 93 and 96% concentration and fuming acid containing 15% by weight of free sulphur trioxide are commonly employed. The weaker acids combine with or dissolve more reactive olefinic components of the petroleum fraction. As the acid strength is increased, the less reactive components are affected and when fuming acid is used oxidation

of the least reactive constituents occurs, even at ordinary temperatures. The extent of the chemical and solvent action of sulphuric acid varies with the temperature of treatment as well as the concentration of the acid. By maintaining temperatures as low as  $-1^{\circ}$  to  $4^{\circ}$ o. ( $30-40^{\circ}$  F.), the more reactive olefins and a large percentage of the sulphur compounds present in cracked gasolines may be selectively removed by sulphuric acid of 76-90% concentration without affecting the majority of high octane rating olefinic components. Kerosene treatments employ fuming acid at temperatures up to  $93^{\circ}$ o. ( $200^{\circ}$  F.) for the purpose of taking out most of the aromatic and a portion of the naphthenic constituents to improve burning properties.

Of the hydrocarbon groups, paraffins are the least affected by sulphuric acid, although methane is the only member of the series that does not react at all at normal temperature with any strength of sulphuric acid. Even the gaseous paraffins, ethane, propane, and butane are slowly attacked by fuming acid, and the higher molecular-weight members of the paraffin series are increasingly soluble in the, stronger acids. In many treatments of petroleum distillates containing unsaturated constituents with relatively small amounts of acid, paraffins are substantially unaffected.

Cyclic paraffin hydrocarbons are somewhat reactive toward strong sulphuric acid, and some are soluble in the mixture of acid and reaction products constituting the acid sludge. Naphthenic hydrocarbons are sulphonated by acid of 06% concentration and undergo slow oxidation and dehydrogenation. The effect on naphthenes of light acid treatments is negligible in the presence of more reactive compounds.

The aromatic constituents of petroleum are definitely reacted upon in sulphuric acid treatments, benzene and lower alkylbenzenes undergoing some sulphonation by acids as low as 91% concentration. 85% sulphuric acid may be used to remove toluene from cracked distillates. While 93% acid removes large amounts of aromatics from kerosenes, the fuming acid is necessary to reduce the aromatic content to a point corresponding to good burning properties. Owing to the high losses suffered in such treatments, it is now customary to extract the aromatic compounds by selective solvents, such as liquid sulphur dioxide which does not destroy the aromatics, and depend upon a mild treatment with sulphuric acid to supplement solvent extraction.

Of the hydrocarbon groups, the aliphatic hydrocarbons containing double and triple bonds, including olefins, diolefins, and acetylenes react with acid of as low as 75% concentration at ordinary temperature. The reactivity of these unsaturates and the types of compounds which they form vary with their molecular weights and structures. In general, lower molecular weight compounds are more active. When a wide range, minimum amounts of acid and 1:1 conditions of treatment are utilised to remove the hydrocarbon constituents which are unstable in respect to gum formation, whilst leaving unaffected mono-olefins which

contribute to the anti-knock value of the gasoline.

Sulphuric acid causes a number of olefin transformations; some are polymerised to higher boiling hydrocarbons, some form neutral esters, and some form secondary and tertiary alcohols. At relatively low temperatures polymerisation stops short of tar formation. Some of the lower molecular weight polymers, alcohols, and alkyl sulphates remain dissolved in the oil, and in the redistillation of an acid treated, neutralised, cracked naphtha, a maximum temperature of  $177^{\circ}$ o. ( $350^{\circ}$  F.) should not be exceeded, and steam should be used to prevent decomposition of alkyl sulphates into unstable hydrocarbons, alcohols, and sulphur compounds which form gums and colour in the distillate. Treatment of cracked distillates with relatively large amounts of sulphuric acid produces sulphonic acids which are removed by alkalis. Large amounts of acid also dissolve alkyl esters and sulphonic acids. When large amounts of strong acid are used in the treatment of distillates containing large amounts of olefins of the order of 10-20%, some alkylation of paraffins, aromatics, and naphthenes by olefins occurs to an extent depending upon such factors as the molecular proportions of the hydrocarbon groups, strength of the acid, temperature, and the time of contact.

The practice of treating kerosene with strong sulphuric acid to improve its colour, odour, and burning properties began in the early days of the refining industry and still continues to be used on some distillates which require purification to meet market specifications. Other methods of treatment involving the use of liquid sulphur dioxide and specific absorbents for removing smoking hydrocarbons now compete with older methods, and in some instances supplant the sulphuric acid method of treatment. In producing kerosene having satisfactory burning properties from Californian and Gulf Coastal fields by sulphuric acid treating, it is sometimes necessary to employ fuming acid in amounts as high as a pound per gallon of raw kerosene to remove the cyclic hydrocarbons, which impart smoking properties to the oils. In such cases the use of liquid sulphur dioxide to extract the major portion of the smoke-producing hydrocarbons reduces the amount of acid needed.

In the older methods of treating petroleum distillates with sulphuric acid treatments are conducted in vertical, cylindrical cone-bottomed tanks called "agitators," contact with the acid and oil being brought about by air-blowing, mechanical stirrers or circulation with outside pumps. After the treatment the spent acid settles in the cone, from which it is withdrawn, and the oil is then treated with an aqueous solution of sodium hydroxide in sufficient excess to assure neutralisation of acidic components.

Treatments with liquid reagents such as sulphuric acid are also conducted in continuous plants which comprise essentially mixing devices, such as pipes containing baffling material, through which the acid and oil are forced together by pumps, and enlarged settling tanks in which time is given for the separation of the spent acid as a lower layer. The supernatant oil is then forced through similar mixing devices



along with an alkali and then into a final settler where the neutral oil is separated from the spent alkalis. Many modifications of continuous treating processes are employed in petroleum refineries. Fig. 35 shows the flow in a plant for the continuous treatment of gasoline with sulphuric acid followed by water washing, neutralization with caustic soda, and sweetening with so-called "doctor solution" (sodium plumbite).<sup>1</sup>

When lubricating distillates are treated with sulphuric acid, sludge separation\* is slow and difficult, and the treated oils containing acid particles in suspension are passed through high-speed centrifuges to separate the acid particles and clarify the oil. Intermediate water washing is usually practised between the acid and alkali treatments, and final water washing may be employed to take out alkaline products and soaps. An alternate method for

removing sludge particles from acid treated lubricating oils consists in adding powdered absorbents, such as acid treated clays of the Montmorillonite type. Such absorbents coagulate the sludge particles and at the same time absorb acid compounds so that the filtered oil is simultaneously neutralised and clarified.

Sulphuric acid of a moderate concentration quickly coagulates and removes asphaltic and resinous components in petroleum. This may be effected with acid as weak as 40%. Some of these types of constituents are dissolved by the acids and some form an intermediate tar layer.

Oxygenated compounds such as naphthenic acids, alcohols, ketones, and phenols respond differently to various strengths of sulphuric acid. Although most petroleum distillates contain only small percentage of such compounds, they are not completely removed by acid treatment; some are sulphonated, some are oxidised, and

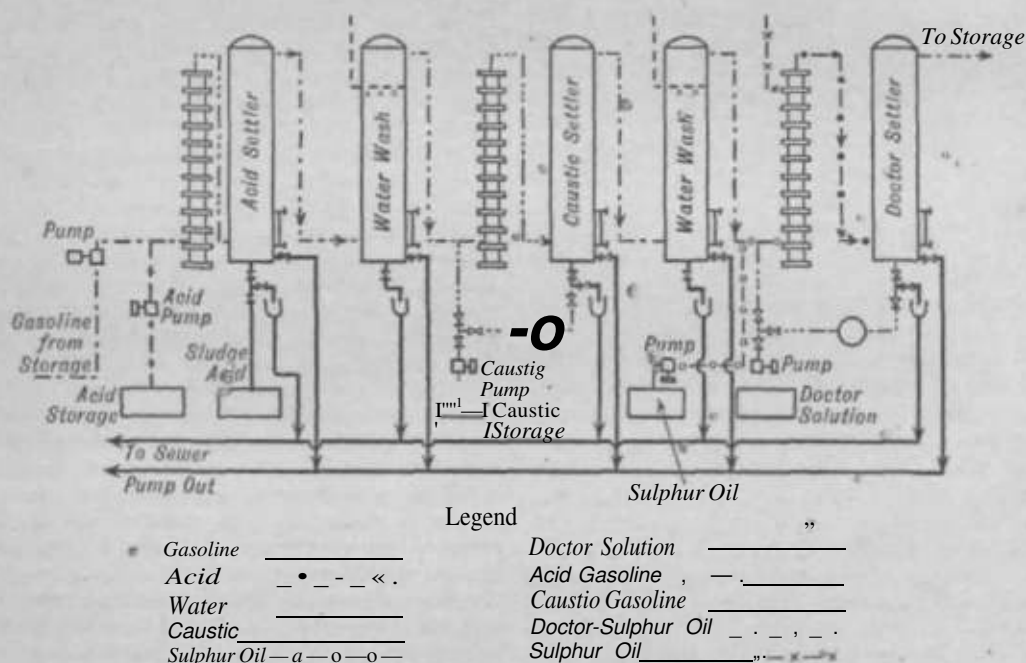

FIG. 36.

some are dissolved. Phenols are not removed by cold concentrated acid.

Jinny petroleums contain small amounts of nitrogen compounds, from a trace to as high as 20%. Since most of these are types of pyridine or quinoline, they are basic and removable by sulphuric acid of about 25% concentration.

The effect of sulphuric acid on the sulphur compounds in petroleum oils is variable and depends upon the concentration of the compounds, strength of the acid, and temperature. Hydrogen sulphide reacts with 93% acid to form free sulphur and sulphur dioxide. This compound should, therefore, be removed from distillates by alkalis before sulphuric acid treatment. Mercaptans are oxidised to disulphides which are partly soluble in the acid. For this reason mercaptans should be removed or converted to dialkyl disulphides by a "sweetening" treatment before sulphuric acid is used. For complete removal of mercaptans, fuming acid is

necessary, since alkyl disulphides are not completely soluble in acids of lower concentration. Thiophenes are sulphonated by fuming and 93% acid. Sulphoxides and sulphones are readily soluble in 93% acid. Alkyl sulphates produced in acid treatments are not all removed from the treated oil by the acid.

The use of sulphuric acid in treating petroleum distillates is expensive, not only on account of the consumption of acid, but also the corrosion problems encountered. Treatments with weak acids must be conducted in lead-lined or other corrosion-resistant apparatus. Since practically all types of sulphur compounds are encountered, including hydrogen sulphide, sulphur dioxide, and sulphuric acid.

The spent acid from relatively light treatments may be partly recovered for re-use by (1) Dilution of the sludge with water to separate tars and insoluble reaction products; (2) concentration of the separated dilute acid in lead-lined pans,



up to about 88 or 90% acid; (3) further concentration of the acid in iron pans to the desired strength, usually 93-12% by weight H<sub>2</sub>SO<sub>4</sub> (sp.gr. 1.842).

Recovered acid is black on account of the presence of high molecular-weight tarry compounds and cannot always be used in the treatment of oils to produce water-white products, since some of the colouring matter redissolves in the oil. However, a supplementary treatment with fresh acid can be used to remove the coloured products. Sludges from treatments with acids of high concentration at elevated temperatures may contain only small amounts of free acid, and such sludges may be more economically burned under boilers or stills than subjected to recovery processes.

### Alkali Treatments.

Various alkalis are used for removing naphthenic acids and phenolic compounds from primary petroleum distillates. The acids and phenols are recoverable by subsequent acidification of the soap and phenolate solutions. The most commonly used alkali is an aqueous solution of sodium hydroxide, which may vary in concentration from as low as 1% to as high as 30% by weight. A preliminary treatment with sodium or potassium hydroxide solution removes hydrogen sulphide. After sulphuric acid treatment alkalis are used to neutralise free acid and react with acidic reaction products. Alternatively, other alkaline materials such as sodium carbonate, ammonia, ammonium hydroxide, lime, and magnesia have also been used.

### Sweetening.

Many gasolines and particularly those produced by cracking sulphur-containing stocks contain mercaptans, which impart a disagreeable odour to the gasoline. Further disadvantages due to these compounds are that they are corrosive and that they reduce the susceptibility of gasolines to improvement in anti-knock value by the addition of tetraethyl-lead. While other types of sulphur compounds may be tolerated in limited amounts, the substantially complete removal of hydrogen sulphide and mercaptans from gasolines is desirable.

Removal of hydrogen sulphide is readily accomplished by treatment with aqueous sodium hydroxide solutions. However, this reagent does not completely remove higher molecular-weight mercaptans, but only the methyl and ethyl compounds. The earliest process for deodorising gasolines containing mercaptans used an aqueous solution of sodium plumbite, made by dissolving litharge (PbO) in sodium hydroxide solutions of about 10% weight concentration. The sodium plumbite exerts an oxidising effect on mercaptans so that they are converted to dialkyl disulphides. The reactions involved in the sodium plumbite treatment are as follows:

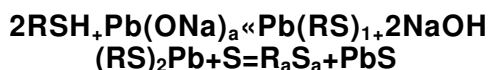

The second reaction is complete unless the oil contains a sufficient quantity in solution. The disulphides

which remain in the oil are odourless but they lower susceptibility of some gasolines to anti-knock improvement by addition of tetraethyl-lead.

Alternative treatments to the sodium plumbite process include a number which depend upon similar oxidising effects. These include hypochlorous acid, sodium and calcium hypochlorites, chlorine, and ammoniacal solutions of copper salts. While many of these have been used with good success for deodorising, none of them remove appreciable amounts of sulphur from the oil.

Later processes have been developed which remove mercaptans instead of merely converting them to odourless sulphur compounds. These processes employ alkaline reagents containing chemicals which promote the solubility of the mercaptans. One of the commercially successful processes is the "Unisol" process which uses aqueous sodium hydroxide containing methanol.<sup>116</sup> This type of reagent takes out substantially all mercaptans and the spent material is readily regenerated by steam distillation, which vaporises methanol and mercaptans, the sodium hydroxide remaining as a residue. In the "Solutiser" process, a compound such as sodium tiobutyrate is added to aqueous sodium hydroxide to increase the solubility of the mercaptans.<sup>116</sup> In the regeneration step, tannin is added to promote the oxidation of sodium mercaptides.<sup>117</sup> In another process, known as the "Mercapsol" process, aqueous sodium hydroxide containing naphthenic acids and cresol is used to extract the mercaptans.<sup>118</sup>

### Absorbents.

One of the earliest methods for the physical separation of undesired constituents of petroleum fractions was filtration through beds of granular absorbent materials. In order to lighten the colour of lubricating stocks, they are percolated through granular carbon such as bone char or fuller's earths at moderately elevated temperatures of the order of 60-71° C. (140-160° F.). Such types of absorbents exhibit a selective action on colouring matter, suspended resins and asphaltic substances, and polymerisable compounds. They are also used to neutralise oils by the removal of acids, alkalis, and soaps. In addition to lubricating oils, paraffin wax, vaseline, and medicinal oils are bleached by absorbents.

A variety of absorbent materials have been employed with varying success. Among these are animal, vegetable, and mineral chars, the so-called activated carbons, ferric hydroxide, and silica and alumina gels. The absorbents most commonly used at the present time are those made by the activation of Bentonite clays and JMontmorillonite. The last-named mineral is a hydrated aluminium silicate with a high silica-alumina ratio (4:1), which is further increased by treatment of the raw mineral with sulphuric or hydrochloric acid to extract oxides of iron, calcium, magnesium, and a portion of the aluminium, the acid-treated material containing some uncombined silica. These materials are in a finely powdered condition and oils are treated with them by what is known as the con-

tact method. The powder is stirred in the hot oil until the desired absorbent effect is complete, after which the particles of absorbent contaminated with impurities are removed by settling and filtering.

In one vapour-phase treating process, naphtha vapours direct from the fractionator of a cracking plant are passed through beds of granular fuller's earth to remove gum-forming constituents, some cracked stocks requiring no further treatment other than a light alkaline wash to render them marketable (Gray process). Another commercial vapour-phase process passes the vapours of cracked distillates through granular bauxite at temperatures of 316-371°o. (600-700°\*) under moderate super-atmospheric pressures of about 100 psi.<sup>119</sup> This treatment is effective in breaking down mercaptans to hydrogen sulphide, which can be readily removed from the distillates by sodium hydroxide solutions. In the hot clay treatment for cracked naphthas, the condensate from the cracking plant is reheated to temperatures of the order of 204°o. (400°F.) and pumped under super-atmospheric pressure through fuller's earth. This process effects about the same degree of purification as the vapour-phase methods.

#### Solvent Extraction.

Various solvents are used selectively to remove objectionable constituents from gasolines, naphthas, kerosenes, and lubricating oil stocks without chemically altering them. Many solvents have been employed, some with commercial success. Among these are included methanol, liquid sulphur dioxide, nitrobenzene, *bis*-2:2-dichlorethyl ether ("*chlorex*"), methylene dichloride, triethanolamine, furfural, and various phenols. Of these, liquid sulphur dioxide has found the most extensive commercial use, this liquid having great selectivity for the non-hydrocarbon organic constituents of petroleum, and for aromatic and olefinic hydrocarbons. The majority of the solvents employed have similar selective action in varying degrees. Some are more effective in removing aromatics, others for selectively dissolving olefins. Practically all solvents remove large proportions of the sulphur compounds. The liquid sulphur dioxide process developed in Rumania by Edlaneau has been used in treating kerosene, turbine oils, electrical insulating oils, and lubricants. Solvent extraction processes are operated both batch and continuously with counter-current extraction. The success of any solvent extraction process depends on the selectivity of the solvent for removing varying concentrations of impurity. The selectivity may be modified by the use of a mixture of two solvents as in the "duosol" process.

#### PRODUCTS AND USES.

The direct uses of petroleum and its fractions and products from refining processes are as fuels, illuminants, lubricants, binders, sealing and preserving materials, solvents, and medicinals. Under the fuel heading are included fuels for internal combustion engines, which in turn can be sub-divided into gasoline and diesel fuels,

and fuels for domestic and industrial heating, steam generation, etc. Natural hydrocarbon gases associated with petroleum, gases produced incidental to cracking for motor fuels, and gases produced by more intensive cracking are also used for fuel purposes. Kerosene is used as a fuel as well as an illuminant, and the so-called gas or furnace oils are used for cracking, heating, or diesel fuel purposes, depending upon their characteristics. The majority of crude oils yield lubricants as heavy distillate fractions from a primary fractional distillation. Asphaltic petroleum yields heavy tar-like residues having adhesive and ductile properties, and some oils contain sufficient percentages of solid paraffins for the manufacture of refined waxes, petrolatum, etc.

#### Petroleum Gases.

Nearly all petroleum is associated in nature with hydrocarbon gases, the pressure of which assists in forcing them to the surface; although there are many occurrences of natural gas unrelated to petroleum and some occurrences of petroleum in the absence of gas pressure. The principal component of natural hydrocarbon gases is methane, which is presumed to have resulted from the fermentation and decomposition of organic matter, since it is readily produced by bacterial fermentation of cellulose materials and other organic substances. Natural gas also permeates coal deposits from which it is evolved in enormous quantities as the deposits are penetrated.

The characteristic components of natural hydrocarbon gases are methane, ethane, propane, and the butanes. Hydrogen, carbon monoxide, oxygen, olefins, and acetylene are absent. Many natural hydrocarbon gases contain appreciable amounts of carbon dioxide, nitrogen, and hydrogen sulphide; a few contain helium. The gases associated with petroleum and coal are distinct from those associated with volcanic activities. The latter consist mainly of steam, but also contain varying amounts of hydrogen, oxygen, nitrogen, argon, helium, hydrogen chloride, chlorine, hydrogen fluoride, silicon fluoride, and methane. A certain amount of methane, along with hydrogen, nitrogen, and carbon oxides is evolved on heating rocks. Some rock salts yield methane on heating. As a rule the methane content of gases evolved from coal deposits is higher than that of gases associated with petroleum.

The methane content of natural gas may be nearly 100% or it may be as low as 10%, with all intermediate gradations. The average methane content is 75-85%. Ethane varies from 0% to as high as 60%. Carbon dioxide contents of 1-5% are common, although this gas may be completely absent. In unusual cases the gas may contain 25% carbon dioxide, and a few natural gases consist entirely of this compound. Gases containing 88% nitrogen have been noted. The specific gravity referred to air varies from that of pure methane having a figure of 0.57 to gases with a low methane content having a specific gravity as high as 0.89. Heating values may vary from 100 to over 1,300 B.Th.U.'s per cu. ft.

Natural gases associated with petroleum are usually "dry," which term means that they are deficient in the heavier hydrocarbon components and contain less than 0.1 gallon of normally liquid hydrocarbons per thousand cubic feet of gas. Natural gases dissolved in petroleum at high underground pressures and released as the oil is brought to the surface of the ground contain greater quantities of the vapours of normally liquid compounds, so that some yield over a gallon of gasoline per thousand cubic feet of gas. Gases yielding 0.3 gallons and more of gasoline per thousand cubic feet are classified as "wet." Natural gasoline thus recovered contains n-butane and n-pentane, n-hexane, n-heptane, and n-octane; the

higher the molecular weight the less the proportion. cycloPropane, cycloZobutane, and cyclopentane have been identified, and also small amounts of neopentane, trimethylethane, and dimethylpropylmethane. Benzene, toluene, and m-xylene have been found in some natural gasolines.

Analyses of some American natural gases are shown in Table XXXIII, along with their heating values and specific gravities referred to air.<sup>120</sup> The analyses are typical and indicate the variations in composition which may normally be expected. The methane content varies from a high of 99.2% to a low figure of 32.3%. Ethane varies from 0 to 67%, carbon dioxide from 0 to 26.2%, and nitrogen from 0.6 to 38.4%.

TABLE XXXIII.—ANALYSES OF NATURAL GASES FROM AMERICAN FIELDS.

State.	COMPONENT.				B.Th.U. per cu. ft., 0°c.	Sp.gr. (air=1).
	Methane (CH <sub>4</sub> ).	Ethane (C <sub>2</sub> H <sub>6</sub> ).	Carbon dioxide (CO <sub>2</sub> ).	Nitrogen (N <sub>2</sub> ).		
Alabama	97.6	0.0	0.3	2.10	1,039	0.57
Arkansas <sup>3</sup>	99.2	0.0	0.2	0.6	1,057	0.56
California	59.2	13.9	26.2	0.7	889	0.88
Illinois	37.5	69.6	0.0	1.7	1,591	0.86
Kansas	96.4	1.3	0.9	1.4	1,051	0.58
Kansas	62.2	18.38	—	18.64	930	—
Kansas	90.5	2.5	0.4	6.6	1,010	0.60
Kansas	83.0	8.64	—	7.95	970	—
Kentucky	76.4	22.6	0.0	1.0	1,234	0.67
Louisiana	96.5	0.0	1.4	2.1	1,028	0.58
Missouri	92.6	4.3	0.6	2.5	1,066	0.59
New York	84.0	15.0	0.0	1.0	1,174	0.63
New York	78.1	19.9	0.0	2.0	1,202	0.64
Ohio	83.5	12.8	0.0	3.7	1,127	0.63
Ohio	83.5	12.5	0.2	3.8	1,122	0.63
Oklahoma	93.1	5.7	0.4	0.8	1,098	0.59
Oklahoma	70.7	18.66	—	9.32	1,025	—
Oklahoma	88.6	6.6	1.4	4.4	1,048	0.61
Pennsylvania	90.0	9.0	0.2	0.8	1,126	0.60
Pennsylvania	32.3	67.0	0.0	0.7	1,591	0.89
Texas	60.6	10.9	0.1	38.4	742	0.77
Texas <sup>1</sup>	84.0	12.0	—	2.5	1,060	—
Texas	98.0	0.0	0.7	1.3	1,044	0.57
Texas	50.6	10.9	0.1	38.4	742	0.77
West Virginia	82.0	17.0	0.1	0.9	1,189	0.64

The still vented from the gasoline receivers in many petroleum distillation plants are valuable sources of propane, butanes, and pentanes. These natural gases are more soluble in oil than in air, and the lighter petroleum therefore yield gases containing smaller amounts of methane and larger amounts of ethane, propane, butanes, and heavier hydrocarbons.

Natural gases are widely distributed in the United States, Canada, and Mexico, and the oil-producing areas in South America. They also occur in Poland, Russia, Italy, Iran, Australia, and Japan.

Underground pressures as high as 4,000 lb. per sq. in. have been encountered, and in many

places there are continual seepages of gas to furnish fuel for perpetual fires, as on the Caspian Sea near Baku. Commercial use of natural gas is recorded in the United States as early as 1821, and a five-mile pipeline was built in Pennsylvania in 1876 to supply the city of Titusville. In 1889, 250 billion cu. ft. of natural gas was marketed in the United States,<sup>122</sup> and in 1944 the amount had grown to nearly 3.75 trillion cu. ft.<sup>123</sup>

In 1944 the estimated reserves of natural gas in the United States were 110 trillion cu. ft. Table XXXIV shows the growth of reserves and the production in the United States from 1926 to 1945.<sup>124-127</sup> Various experts have given estimates ranging from 110 to as high as 300

• One U.S. billion-10; one U.S. trillion-10".

trillion cu. ft.<sup>125</sup> One authority states the figure at 200 trillion cu. ft.<sup>128</sup>

TABLE XXXIV.—GROWTH OF NATURAL GAS RESERVES AND PRODUCTION IN THE UNITED STATES.

Year.	Estimated proved reserves January 1.	Total (a) production for year.	Ratio of reserves to production.
	(Trillion cubic feet.)		
1926	23 (b)	1-88 (?)	12-2
1931	46 (c)	2-58 (a)	17-8
1935	62 (d)	2-40	25-8
1938	66 (d)	2-95	22-4
1939	70 (e)	3-15	22-2
1941	85 (d)	3-44	24-7
1943	110 (f)	4-00 (ff)	27-5
1944	110 (</)	3-64 (112)	30-2
1945	135 (i)	4-30 (127)	31-3

(a) Gas marketed plus gas lost and wasted as reported by United States Bureau of Mines.

(b) Private estimate.

(c) By Earle P. Hlndes.

(d) By Ralph E. Davis.

(e) By L. F. Terry.

(f) Petroleum Administration for War, including solution gas and gas cap reserves.

(g) Marketed production per United States Bureau of Mines, plus estimate of losses and waste.

(h) Preliminary estimate.

The principal use of natural hydrocarbon gases is as fuel for domestic and industrial heating. Large volumes of natural gas are used in the manufacture of carbon black by smothered combustion, these blacks being used in rubber, ink, and paint. From 1-85 to 2 lb. of carbon black is obtained per thousand cubic feet of gas burned. In 1943, 593,421,000 lb. of carbon blacks were produced from natural gas in the United States, principally in plants in Louisiana and Texas.

Helium is one of the important products obtained from natural gas.<sup>129</sup> The chief source of production is from gases in Texas, Kansas, and Oklahoma in the United States, and Ontario and Alberta in Canada. The amount of helium present in these gases varies from a fraction of 1% up to about 16%. Helium is obtained from the liquefied gaseous mixture by fractional distillation in about 98% purity. Its main use is for the inflation of dirigible aircraft, although it has been used in fireproofing of high-tension switch<sup>^</sup>, in gas mixttires for resuscitation of suffocation victims, in the welding and annealing of metals, and in electric-discharge lamps.

Both methane and ethane and also mixtures of propane and butanes have been compressed and used as motor fuels.<sup>130</sup> Methane has been used as a compressed gas and as liquid methane (v. Vol. VIII, 16), although the low temperatures which must be maintained in the latter case are a disadvantage. [Critical temperature of methane is -82-5°o. (-116°F.), and the critical pressure is 660 psi. gauge.] Methane is supplied in cylinders under pressures of 3,000-5,000 psi. for motor-fuel purposes. The methane which is used for motor fuel in Europe is obtained from natural gas, gases from petroleum refining, coal hydrogenation, Fischer-Tropsch hydrogenation of carbon monoxide, coal carbonisation, coal mining, and the fermentation of city sewage.

Liquid propane-butane mixtures are marketed under pressure in cylinders for motor fuel and for domestic heating. These mixtures usually contain propane, n-butane, and isobutane. The octane ratings are around 100, being higher when they contain higher percentages of propane. Such mixtures are used i^ot only in Europe but in continental United States. One commonly used mixture consists of 50% n-butane, 30% isobutane, and 20% propane by volume.

Natural gas stripped of its gasoline content is used for repressuring oil-bearing formations to restore petroleum production in depressed fields or to maintain oil-field pressures.

#### Natural Gasoline.

By the use of cooling, compression, and absorption methods, large quantities of gasoline are recoverable from the ~" wet " natural gases to supplement the production by distillation and cracking of petroleum and their fractions. The natural gasoline industry has grown rapidly in the ten years preceding 1944. Table XXXV shows the annual production in the United States during this period.<sup>131-132</sup> In addition to the 1944 production of natural gasoline shown in the table, over 27,000,000 barrels of similar products were manufactured from refinery gases, bringing the total to 100,000,000 barrels.

TABLE XXXV.—U.S. NATURAL GASOLINE PRODUCTION BY YEARS.

Year.	Natural gasoline produced (barrels).
1934	36,556,000
1935	39,333,000
1936	42,770,000
1937	49,177,000
1938	61,347,000
1939	51,650,000
1940	55,249,000
1944	100,637,000 <sup>18a</sup>

#### Gases from Cracking.

In cracking petroleum fractions with H<sub>2</sub> the primary object of producing motor fuel; there is a concomitant production of gases which contain, in addition to the hydrocarbons present in natural, casing head, or still gases, hydrogen and unsaturated hydrocarbons. The latter include ethylene, propylene, and butylenes, their percentages depending upon the severity of the cracking conditions employed. In addition, these gases contain small amounts of hydrocarbons containing more than four carbon atoms per molecule, which are normally liquid. Gases from severe cracking at high temperatures of the order of 593-760°c. (1,100-1,400°r.) contain acetylene, diolefins such as butadiene, and cycloolefins.<sup>183</sup> If the oil cracked contains sulphur, the cracked gas mixture will contain hydrogen sulphide and mercaptans. The gas from the cracking of oils containing oxygen compounds may contain carbon monoxide or dioxide, and the cracking of nitrogen-containing oils may contain traces of ammonia or alkylamines.

The quantity of gas produced in cracking of gasoline varies with the character of the oil and the extent of cracking. In mild thermal crack-

ing, about 2% by weight of the oil may be converted to \$LS, while in more severe operations over 26% may appear as gaseous products. The Amount of hydrogen in such cracked gases varies from 3% to as high as 11% or 12%, and the total content of olefins may be as low as 3% or as high as 40%. The specific gravity referred to air approaches unity in some cases and the heating values are correspondingly high, frequently around 1,600 B.Th.U.'s per cu. ft. or higher. Analyses of typical gas mixtures from oil cracking plants are given in Table XXXVI.<sup>134-136</sup> Column 1 in the table shows the analysis of the gas from the gasoline receiver in a plant cracking a Mid-Continent gas oil. Column 2 shows the analysis of a mixture returned to the stabiliser column as reflux, and column 3 the g& mixture evolved from the stabiliser in the cracking of the same oil. Column 4 shows the analysis of the total

gas from the thermal cracking of a Mid-Continent reduced crude, one from which motor fuel and kerosene fractions had been distilled. Columns 6 and 6 show comparative analyses of the total gases obtained by the thermal and catalytic cracking respectively of another Mid-Continent gas-oil fraction. The catalyst used was a synthetic silica-alumina composite, and it is noteworthy that the use of this catalyst produced gases containing about twice as much propylene, five times as much isobutane, and larger amounts of butylenes. A further characteristic of the mixture from the catalytic cracking is the greatly increased amount of isobutane, which is about five times the amount of normal butane in the mixture. Columns 7 and 8 show typical analyses of gas mixtures from high temperature vapour-phase cracking of a petroleum distillate. The content of ethylene in these mixtures is from three to eight times that

TABLE XXXVI.—COMPOSITION OF GASES FROM CRACKING.

Component.	1.	2.	3.	4.	5.	6.	7.	8.
Hydrogen	4.3	—	0.1	6.0	9.0	6.0	7.0	8.8
Methane	22.2	0.1	3.4	24.0	26.0	13.0	30.0	40.6
Ethane	17.3	3.2	14.0	13.0	19.0	6.0	12.0	9.9
Ethylene	6.0	0.6	9.0	6.0	3.0	6.0	23.0	26.4
Propane	26.8	2.20	32.6	> 19.0	2.00	11.0	4.0	4.0
Propylene	11.2	1.60	22.6	13.0	1.10	23.0	14.0	8.0
n-Butane	6.4	37.5	6.6	9.0	16.5	3.5	2.0	—
isobutane								
n-Butylenes	4.0	12.0	8.0	12.0	1.60	10.0	6.0	2.3
isobutylenes								
Butadiene	—	—	4.0	—	—	6.0	1.0	—
Pentanes+	0.2	1.2	0.2	—	—	—	—	0.1

1. Gas from gasoline receiver; cracking Mid-Continent gas oil
2. Stabiliser reflux; cracking Mid-Continent gas oil
3. Stabiliser gas; cracking Mid-Continent gas oil
4. Total gas; thermal cracking of Mid-Continent reduced crude"
5. Total gas; thermal cracking of Mid-Continent gas oil
6. Total gas; catalytic cracking of Mid-Continent gas oil
7. Gas from gasoline receiver; vapour-phase thermal cracking (ref. 136).
8. Total gas; vapour-phase thermal cracking (ref. 137).

of the other gas mixtures, while the amounts of propane, isobutane, and butylenes are much lower, butadiene is practically always present in gases from vapour-phase cracking, whereas it is scarcely ever present in detectable quantities in gas mixtures from liquid vapour-phase cracking processes. Butadiene can be produced in amounts corresponding to about 6% by weight in gas mixtures at temperatures of 760-815°C. (1,400-1,500°F.). Vapour-phase cracking also produces gases containing large percentages of hydrogen and methane in comparison with those obtained at lower temperatures. The fractionation of gas mixtures from stabilisers yields mixtures containing butane and butylene which are used in polymerisation plants. The fractionation of gas mixtures from stabilisers yields mixtures containing butane and butylene which are used in polymerisation plants. The fractionation of gas mixtures from stabilisers yields mixtures containing butane and butylene which are used in polymerisation plants.

facture of gases at higher temperatures than those employed in cracking for gasoline. These high-temperature processes are the source of Pintsch gas and Blau gas. The temperatures used in these processes vary from about 700 to 900°C. (1,292 to 1,662°F.), and cracking is conducted in regenerative furnaces containing checker brickwork which is alternately fired to raise its temperature and then used to crack the oil vapours. The ranges in composition of Pintsch gas are given in Table XXXVII.<sup>138</sup>

TABLE XXXVII.

	% by volume.
Hydrogen	10-20
Methane	30-40
Ethane	6-16
Olefins, principally ethylene	20-40

Cracking can be conducted with the object of making ethylene, propylene, and higher olefins at temperatures of 660-860°C. (1,206-1,652°F.) to yield 900-1,400 cu. ft. of olefins and diolefins per barrel of gas oil.

Table XXXVIII shows the yields of gas and olefins per barrel of gas'oil produced in typical refineries.

TABLE XXXVIII.

Temperature.		Yield, cu. ft. per barrel.	Olefins (and diolefins), vol. %.	Olefins, cu. ft. per barrel.
°C.	°F.			
743-785	1,352-1,455	2,800-3,365	27-3-36-6	906-1,094
682-760	1,261-1,400	2,490-2,063	30-1-35-8	891-930
700	1,292	2,520	36*5	919
800-850	1,472-1,562	2,870-3,255	43*1-46*2	1,325-1,402
650-750	1,202-1,382	1,887-2,884	43-6-30*6	825-892

The gases produced by high-temperature cracking have high heating values of 1,200-1,500 B.Th.U.'s per cu. ft. and are used to carbonate water gas and producer gas.

The gases from cracking propane at temperatures of 900-1,200°o. (1,652-2,192°F.) contain increasing amounts of acetylene up to about 15% of the gas mixture and give maximum yields of ethylene at about 1,100°o. (2,012°F.), after which the ethylene yield decreases and the acetylene yield increases. More data on the production of acetylene and its uses is found in the "Special Products" section.

## MOTOR FUEL.

The use of the fractions of petroleum as fuel for various types of internal combustion engines is of major importance at the present time (1945). In the United States, one-half of the volume of petroleum produced is used in internal combustion engines as motor gasoline, aviation fuel, tractor, and diesel fuel. Production of all types of gasoline in 1944 reached 45% of the petroleum charged to refineries in the United States.<sup>182</sup>

The turn of this century marked the transition from the kerosene to the gasoline age, when the automobile appeared as a factor in transportation. The increasing use of the diesel engine in stationary power plants, locomotives, trucks, buses, and ships has required increasing amounts of the heavier distillate and residual petroleum fractions. The latest developments are concerned with special fuels for airplane engines

which require the highest anti-knock gasoline for their operation. Engine fuels may be roughly classified as:

- (i) Gasoline, which powers the great majority of automotive land vehicles,
- (ii) Aviation fuel, used in the high-compression motors of airplanes,
- (iii) Fuels used in high- and low-speed diesel engines for vehicles of all types, and in stationary power-plants,
- (iv) Tractor fuel.

## Gasoline.

Gasoline is a mixture of hydrocarbons boiling from approximately 38° to 204°o. (100° to 400°F.) obtained from petroleum or other hydrocarbon sources. The end-boiling-point varies from 177° to 260°c. (360° to 500°F.). Such hydrocarbon mixtures are produced in the primary or straight-run non-destructive fractional distillation of petroleum, in the cracking of its heavier fractions, and in syntheses involving polymerisation of gaseous olefins, or the alkylation of wobutane or benzene with low boiling olefin hydrocarbons. The suitability of a gasoline for use in a given engine depends upon a large number of factors, including the relative proportions and boiling-points of the paraffinic, olefinic, cycloparaffinic and aromatic hydrocarbons which it contains, and the molecular structures of these compounds. Before the automobile began to cause excessive demands for gasoline and before the use of increased compression ratios to seek higher thermal efficiencies in the engines, the market for gasoline was supplied by straight-run products boiling from normal temperatures up to about 150°J. (300°F.). As volume requirements increased, the end boiling-point was raised and the cracking process developed to augment the supply of natural product. In the interval between 1920 and 1944 in the United States, the volatility of gasoline as determined by its distillation test figures experienced considerable variation, as shown in Table XXXIX, which gives average values for marketed fuels.<sup>140</sup> ->

The data in the table show that gasoline has become considerably more volatile from 1920 until about 1942. Up to the latter year all indicated boiling-points were becoming lower,

TABLE XXXIX.—BOILING-POINTS OF GASOLINE (U.S.A.).

Year.	Initial b.p.		10%.		50%.		90%.		End b.p.	
	°C.	°F.	°C.	°F.	°C.	°F.	°C.	°F.	°C.	°F.
1920-Jan.	48	119	78	172	126	259	187	369	219	427
July	54	130	83	182	131	268	198	388	230	446
1926-Jan.	34	93	68	155	129	264	193	380	217	423
July	38	100	72	162	130	266	194	382	216	421
1930-Jan.	34	93	59	139	124	256	188	371	208	406
Aug.	38	100	68	155	129	265	187	368	207	405
1940-July*	39	102	63	145	114	238	172	341	201	393
1941-Jan.*	33	91	54	130	109	228	170	338	199	391
1942-Jan.*	34	93	53	127	108	226	166	331	105	383
1943-July*	38	101	59	139	113	236	168	334	201	393
1944-Jan. >	34	93	55	131	117	242	174	345	205	401
1944-July*	39	103	63	146	123	253	178	353	208	407

\* Average of premium, regular, and third-grade fuels.

although seasonal variations were still in evidence. The figures for 1944 show the effect of wartime conditions, particularly in regard to the 10, 50, 90, and end boiling-points, although the initial boiling-points show no significant change.

The use of increased compression ratios brought to light the fact that gasolines of certain types exhibited a tendency to "knock" or detonate, with resulting loss in engine power and efficiency. Originally motor fuels were graded in respect to their knocking tendencies by comparing them in standard test-engines with blends of straight-run gasolines having high knocking properties, and either aniline or benzene having anti-knock properties. Between 1922 and 1930, extensive researches on the knocking problem evolved woodtane as a standard non-knocking hydrocarbon and brought improvements in standard test engines. The knocking tendencies of gasolines are determined in one-cylinder engines of standardised design by comparing the performance of an unknown fuel with the performance of mixtures of n-heptane, to which a zero anti-knock rating is assigned, and an iso-octane, 2:2:4-trimethylpentane, which is given an arbitrary rating of 100. The volume percentage of fioctane in a blend with n-heptane which duplicates the performance of an unknown sample in a test engine is taken as its octane number (v. Vol. VIII, 632c). Since the power developed and knocking tendencies of a fuel are influenced both by the speed of the engine and the richness of the fuel-air mixture ted to the cylinders, full-range testing is practised to enable more complete evaluation of fuels under varying conditions of load and speed. The anti-knock value of aromatic hydrocarbons increases slightly as engine speeds increase, -hat of olefinio hydrocarbons decreases considerably, and that of paraffinic hydrocarbons decreases slightly.

The method for testing gasolines to determine their knock characteristics has been tentatively standardised by the American Society for Testing Materials under their test designation D-357-37T. This method of determining octane numbers is commonly referred to as the A.S.T.M. or Kv,k>r' Btaohod. At the present time this octane number is the most important single property of a spark-ignition internal-combustion engine fuel. The compression ratio of United States passenger cars increased from 5.3 in 1931 to 6.7 in 1942, and in this same period the anti-knock quality of fuels increased as shown in Fig. 36 to a maximum in 1941 and 1942. The drop in quality from this time to 1945 was because of increased wartime demands for automotive and particularly high anti-knock aviation fuels. At the termination of the Asiatic conflict in August, 1945, aviation-fuel demands dropped sharply and upward trends in anti knock value of motor fuels were soon observed. However, these trends were not uniform.

The tendency of a gasoline to knock is dependent on the design and operation of the engine, so that the octane number determined in a standard one-cylinder test engine is an empirical figure not always related to knocking in a multi-cylinder automobile engine. However, the value indicates roughly the performance to be expected in an automobile running under rather

severe conditions of load and speed. Higher octane numbers mean generally higher efficiencies, although there is no advantage in employing a fuel having an octane number higher than that necessary to avoid knocking in a given engine.<sup>148</sup>

There are four requirements for a satisfactory gasoline:

1. Its volatility should be controlled to permit easy starting, quick warm-up of the engine\* satisfactory acceleration of the car; no dilution of crankcase lubricants and no vapour lock due to excessive vaporisation in the carburetter;
2. Its octane number should be high enough to eliminate detonation;
3. It should contain no gum-forming compounds;
4. It should be free of abrasive or corrosive materials.

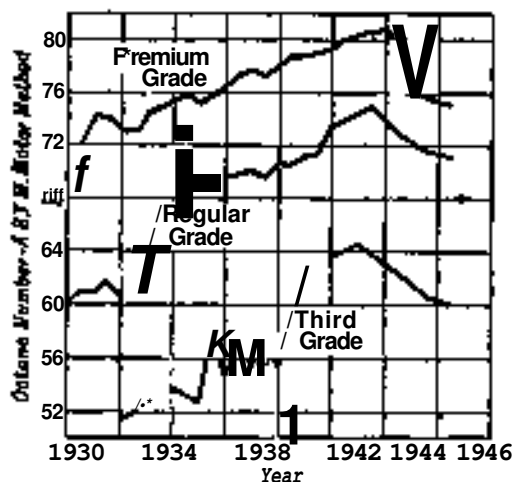

FIG. 36.

As a result of many tests it has been determined that:

1. The initial boiling-point of a gasoline is without significance;
2. The 10% boiling-point determines the ease of starting and the tendency to vapour lock;
3. The 50% point controls the warming up period,-
4. The 90% point (since it indicates the dew point, which in turn determines the proper manifold temperatures), influences power output, engine economy, and satisfactory acceleration, and indicates possibilities of crankcase lubricant dilution;
5. The end point has minor significance.

The determination of the vapour pressure of a gasoline in a standard bomb at 38°o. (100°r.) gives another indication of its volatility characteristics. If the vapour pressure exceeds a certain amount, depending upon the atmospheric temperature and the temperature of the fuel system, too much of the fuel will boil off in the carburetter and the motor will stall because of too lean a mixture in the manifold. At 10°c. (60°F.) the vapour pressure should not be over



14 lb. in the standard Reid test, while at an atmospheric temperature of 38°o. (100°r.) the vapour pressure should not exceed 7 lb. if vapour locking is to be avoided. The Reid vapour-pressure test has been adopted by the American Society for Testing Materials as tentative standard D-323-37T.

The gum content and the potential gum-forming hydrocarbons should be low to prevent plugging of fuel lines and carburettor jets and sticking of inlet valves. Gums are determined by evaporating 100 ml. of gasoline in a small glass beaker on a steam bath. The details of this method for determining the actual gum content of gasoline have been adopted by the American Society for Testing Materials under their designation B-381-D-36. This is now the American Petroleum Institute standard under their number 529-36. Satisfactory gasoline should have no more than 7 mg. of gum per 100 ml. of sample.

The amount of sulphur which can be present in motor fuel without endangering engine parts is higher than most specifications permit. Ventilating systems on the crankcases of present-day automobiles prevent condensation and eliminate any possibility of corrosion by acids of sulphur. Since 1930 restrictions on sulphur content have been eased considerably. The United States government now accepts gasoline containing 0.25% sulphur (1945).

Although for a long time gasolines were marketed on a specific-gravity basis, it is now known that this property does not determine the suitability of a gasoline for use in an engine.

#### Hydrocarbons In Gasolines.

The relative proportions of paraffin, olefin, cycloparaffin, and aromatic hydrocarbons vary markedly in gasolines. Those of the straight-run variety are composed principally of paraffin and cycloparaffin hydrocarbons, though a few contain aromatic hydrocarbons. Cracked gasolines are characterised by higher percentages of both olefinic and aromatic hydrocarbons than are found in straight-run products, the olefins being the typical components. In gasolines of adjusted vapour pressure, the lowest boiling compound will be propane, and there will be

considerable quantities of butanes and pentanes. Prior to the instigation of the American Petroleum Institute Project in 1928 for the separation and identification of hydrocarbons in gasoline, little was actually known of the compounds present, although group analyses indicated the variations in composition. Various methods are used to determine the group composition of light petroleum distillates. These depend upon the relative activities of olefins and aromatic hydrocarbons with sulphuric acid, the determination of halogen numbers and molecular weights of various fractions, the nitration of aromatic hydrocarbons with mixtures of sulphuric and nitric acid and the temperatures of complete miscibility with aniline of residual mixtures of paraffins and cycloparaffins after removal of olefins and aromatics. Many group analyses have been published based on these different methods, which the best are only approximate. In regard to determining relative proportions of normal and branched-chain paraffin and olefin hydrocarbons, the location of side groups, or of double bonds in the case of olefins, available methods are not fully adequate. Infra-red spectra are available for normal and branched-chain paraffin hydrocarbons containing up to eight carbon atoms, but values for all olefins containing up to seven carbon atoms have not been reported, and hence estimation of paraffin and olefin molecules by infra-red methods is definitely limited. The use of all spectroscopic methods involving infra-red, ultraviolet, X-ray, Raman, and other spectra will increase as values continue to be determined on pure hydrocarbons. Some idea of the location of olefin double bonds may be obtained by forming ozonides. Another factor\* entering into hydrocarbon group analyses is that of mixed composition. *E.g.*, styrene may be classed either as an olefin or an aromatic; and a compound such as hexylcyclohexane may exhibit both properties of paraffins and naphthenes, and be classed one time as a hydrocarbon of the former group and another time as one of the latter group, depending upon the method of analysis.

Table XL shows the group composition of different boiling-range fractions of five straight-run distillates.<sup>144</sup>

TABLE XL.—HYDROCARBON COMPOSITION OF 60-300°C. (140-572°F.) FRACTIONS.

Fraction, b.p.		Bibi-Eibat, U.S.S.B.			Mexla, Texas.			Tonkana, Oklahoma.			Davenport, Oklahoma.			Huntingdon Beach, California.		
		Paraffins.	Naphthenes.	Aromatics.	Paraffins.	Naphthenes.	Aromatics.	Paraffins.	Naphthenes.	Aromatics.	Paraffins.	Naphthenes.	Aromatics.	Paraffins.	Naphthenes.	Aromatics.
60-95	140-203	57	40	3	54	17	29	68	26	6	74	21	5	65	31	4
95-122	203-252	45	52	3	57	22	21	58	34	8	65	28	7	46	48	6
122-150	252-302	27	66	7	58	23	19	45	43	12	55	33	12	55	33	11
150-200	302-392	19	69	12	63	21	16	39	41	20	55	29	16	22	61	17
200-250	392-482	27	51	22	68	20	12	44	34	22	52	31	17	30	45	25
250-300	482-572	29	41	30	59	29	12	46	29	25	51	32	17	31	40	25

The data show an upward trend in aromatic content as boiling-points increase, with the exception in the case of the Texas gasoline. The paraffin content invariably decreases as the boiling-point rises. There is no definite trend in the percentage of cyclic paraffin hydrocarbons.

Typical group compositions of commercial thermally cracked gasolines are shown in Table XLI.

TABLE XLI.—COMPOSITION OF GASOLINES FROM THERMAL CRACKING.

Hydrocarbon groups.	Stocks cracked.				
	Bra-man Ton-kawa, Kansas, topped crude.	Ken-tucky fuel oil.	Bmack-aove heavy crude.	North Texas fuel oil.	Lost Soldier, Wyoming, crude.
Vol. % :					
Olefins	16.1	14.4	14.7	16.0	11.7
Aromatics	17.8	22.5	27.5	18.6	15.0
Naphthenes	12.8	10.0	21.2	11.7	16.4
Paraffins	53.3	53.1	36.6	53.7	57.9

The olefin percentages shown are lower than average, which is more like 20-25% with correspondingly lower percentages of paraffins.

Gasolines produced by high-temperature vapour-phase cracking frequently contain 50% olefins and 40% aromatics, with only small amounts of naphthenes and paraffins. Table XLII shows some group analyses of vapour-phase cracked gasolines.

TABLE XLII.—COMPOSITIONS OF GASOLINES FROM VAPOUR-PHASE CRACKING.

Vol. % :					
Olefins	42.4	43.1	38.0	64.5	75.7
Aromatics	57.6	38.6	46.3	28.1	20.8
Naphthenes	—	4.8	7.2	3.8	3.6
Paraffins	—	13.5	8.5	3.6	—
Total	1000	1000	100.0	1000	1000

Polymer gasoline consists largely of mono-olefins containing seven and eight carbon atoms per molecule. Table XLIII shows the composition of a commercial product.<sup>147</sup> Heptenes in such a gasoline include heptene-1, heptene-3, and ethylpentene-2. The eight-carbon-atom olefins include both 2:2:3- and 2:2:4-trimethyl-pentenes.

TABLE XLIII.—COMPOSITION OF POLYMER GASOLINE.

Number of carbon atoms per olefin hydrocarbon molecule.	Mol. % of polymer gasoline.
5.	1.7
6.	6.6
7.	48.1
8.	15.2
11 and higher.	12.3

The octane numbers of polymer gasolines vary from 80 to 82 by the motor method. The value does not vary greatly with change in end point, and the octane blending value exhibited when polymer gasoline is mixed with low octane-rating gasoline is also fairly constant. Table XLIV shows some commercial data on end point, octane numbers, and blending values of commercial polymer gasolines.<sup>148</sup>

TABLE XLIV.

Property.	1.	2.	3.	4.	5.
	°O. °F.	°O. °F.	°O. °F.	°O. °F.	°O. °F.
End b.p.	277 531	266 510	226 439	212 413	211 411
Octane number	81	81	80	82	81
Blending Octane number	118	118	116	120	116

The composition of cracked gasolines is largely dependent upon the nature of the oils cracked. Composition of two gasolines produced as products of catalytic cracking using alumina-silica type catalysts are shown in Table XLV.<sup>47</sup>

TABLE XLV.—COMPOSITION OF GASOLINES FROM CATALYTIC CRACKING.

Hydrocarbon components, %.	Paraffinic gas-oil charge.	Naphthenic gas-oil charge.
Normal paraffins	17	12
Monoparaffins	63	47
Naphthenes	7	25
Aromatics	9	13
Olefins	4	3

The relatively high percentage of paraffin hydrocarbons is noteworthy, this being characteristic of catalytically cracked gasolines and accounting for their observed higher octane numbers in comparison with analogous thermally cracked fractions. The percentage of olefins is lower than in similar thermally cracked products.

The American Petroleum Institute Hydrocarbon Research Project has given the first definite percentages of the normally liquid hydrocarbons actually present in gasolines. Employing strictly physical separations involving distillation, extraction, absorption, and crystallisation, about 60 hydrocarbons have been separated from straight-run gasolines and gases representing different fields in the United States.<sup>148</sup> These hydrocarbons are listed in Table XLVI; 25 of them are paraffins, 15 are

TABLE XLVI.

Formula.	Name.	B. p., °c.	B. p., °f.
$C_6H_6$	Methane	-161.7	-258.0
$C_2H_2$	Ethane	-88.3	-129
$C_3H_8$	Propane	-42.2	-40
$C_4H_{10}$	iso Butane	-11.8	-10
$C_4H_{10}$	n-Butane	-0.5	3
$C_5H_{12}$	2-Methylpropane	9.6	9
$C_5H_{12}$	n-Pentane	36.1	9
$C_6H_{14}$	cyclo-Pentane	49.5	12
$C_6H_{14}$	2,2-Dimethylpropane	49.74	12
$C_6H_{14}$	2,3-Dimethylbutane	68.0	12
$C_6H_{14}$	2,3-Dimethylbutane	69.8	140.5
$C_6H_{14}$	2-Methylpentane	63.6	146.0
$C_6H_{14}$	n-Hexane	68.7	153.7
$C_7H_{16}$	Methylcyclopentane	71.9	161.4
$C_7H_{16}$	2,2-Dimethylpropane	78.9	174.0
$C_7H_{16}$	2,3-Dimethylpropane	80.1	176.2
$C_7H_{16}$	2,4-Dimethylpentane	80.81	176.9
$C_7H_{16}$	cyclo-Hexane	80.8	177.6
$C_7H_{16}$	1,1-Dimethylcyclopentane	87.5	180.5
$C_7H_{16}$	2,3-Dimethylpentane	87.79	183.4
$C_7H_{16}$	2-Methylhexane	90.0	184.9
$C_7H_{16}$	trans-1,3-Dimethylcyclopentane	90.9	185.0
$C_7H_{16}$	trans-1,2-Dimethylcyclopentane	91.9	187.4
$C_7H_{16}$	2-Methylhexane	92.0	197.9
$C_7H_{16}$	n-Heptane	98.4	206.8
$C_7H_{16}$	Methylcyclohexane	100.9	213.9
$C_7H_8$	Toluene	110.6	231.0
$C_8H_{18}$	2-Methylheptane	117.6	243.4
$C_8H_{18}$	1,1-Dimethylcyclohexane (a), kerosene	119.8	247.9
$C_8H_{18}$	1,2-Dimethylcyclohexane kerosene	120.3	248.3
$C_8H_{18}$	trans-1,3-Dimethylcyclohexane (a)	123.4	254.1
$C_8H_{18}$	n-Octane	125.6	257.9
$C_8H_{18}$	Ethylcyclohexane	131.8	269.3
$C_8H_{18}$	2,4-Dimethylheptane	135.3	275.4
$C_8H_{18}$	Ethylbenzene	136.2	277.2
$C_8H_{18}$	Monocyclole (b)	139.7	278.1
$C_8H_{18}$	p-Xylene	139.4	281.1
$C_8H_{18}$	m-Xylene	139.3	285.4
$C_8H_{18}$	2,3-Dimethylheptane (a)	140.7	285.3
$C_8H_{18}$	1,2,4-Trimethylcyclohexane	141.3	289.3
$C_8H_{18}$	4-Methylcyclohexane	143.4	282.3
$C_8H_{18}$	2-Methylcyclohexane	143.3	280.0
$C_8H_{18}$	2-Methylcyclohexane	144.3	291.4
$C_8H_{18}$	o-Xylene	144.2	289.0
$C_8H_{18}$	Monocyclole (b)	145.0	299.0
$C_8H_{18}$	n-Nonane	147.0	296.6
$C_8H_{18}$	iso-Propylbenzene	150.7	303.3
$C_9H_{20}$	n-Propylbenzene	152.4	306.3
$C_9H_{20}$	1-Methyl-3-ethylbenzene	159.5	319.1
$C_9H_{20}$	1-Methyl-4-ethylbenzene	161.6	323.0
$C_9H_{20}$	1,3-di-Trimethylbenzene	162.5	324.5
$C_9H_{20}$	1-Methyl-3-ethylbenzene	164.6	328.2
$C_9H_{20}$	4-Methylnonane	166.1	329.3
$C_{10}H_{22}$	2-Methylnonane	166.7	330.6
$C_{10}H_{22}$	3-Methylnonane	168.8	333.3
$C_{10}H_{22}$	1,2,4-Trimethylbenzene	167.3	334.0
$C_{10}H_{22}$	n-Decane	169.2	336
$C_{10}H_{22}$	1,2,3-Trimethylbenzene	174.0	346.5
$C_{10}H_{22}$		176.1	349.0

(a) Identity ■ definitely established.

(b) Identity ■ yet determined.

cycloparaffins, and the remainder aromatics. All the normal paraffin hydrocarbons up to decane are present, 13 monomethylparaffins, 4 dimethylparaffins, and 11 aromatics. It is worthy of note that more highly branched paraffins than the dimethyl compounds are absent, and there is a relatively small number of hydrocarbons present in comparison with the large number known to boil in the range of the fractions examined. Thus while there are five possible structural isomers among paraffin hydrocarbons containing six carbon atoms, only four of these compounds were found. Similarly, and in a more marked degree, only four heptanes were isolated whilst there are nine possible structural isomers. The lack of branched isomeric compounds is still more striking in the case of the eight-carbon atom paraffins, of which only two were found, whilst eighteen are structurally possible. Among the nine-carbon atom paraffins, five were identified, whilst a total of thirty-five structural isomers is possible.

The octane ratings of hydrocarbons depend upon their boiling-points and their molecular structures.<sup>160</sup> In general, the lower boiling hydrocarbons and those having more compact carbon-atom structures show higher octane ratings. The rules governing octane rating in relation to structure are complex and present some anomalies. In the paraffin series the more highly branched molecules in a group of isomers give the better octane numbers. *E.g.*, increasing anti-knock properties are noted in the octane group in the order of n-octane, methylheptanes, dimethylhexanes, trimethylpentanes, and tetramethylbutane.

In the mono-olefin group higher octane ratings are shown by the more highly branched members, but another factor also enters in the position of the double bond, so that, *e.g.*, 2:2:3-trimethylpentene-1 will have a different octane rating from 2:2:3-trimethylpentene-2.

In the cycloparaffins, the octane number depends upon the molecular weight and position of substituent groups. If these groups are straight-chain aliphatics, the octane numbers will be higher than if they are branched-chain aliphatic radicals. Also, the point of linkage to the aliphatic group influences the anti-knock rating. The octane rating of a trimethylcyclohexane is different from that of propylcyclohexane.

Among the aromatics, the octane ratings are also influenced by the number, type, and position of substituent groups. Thus, toluene has a higher octane number than benzene, and cumene (propylbenzene) has a higher octane number than benzene or toluene.

Tables XLVII to LI show the names, structures, and octane ratings of a number of paraffin, olefin, cycloparaffin, and aromatic hydrocarbons<sup>1w</sup> (*c/*. Vol. VIII, 639a). Some of these are present in gasoline and some are made by synthetic processes. Straight-run gasolines contain more normal and less branched-chain paraffin hydrocarbons, and branching is not extensive. Synthetic hydrocarbons such as the twoctanes in alkylates are absent in straight-run gasolines and present in minor amounts in corresponding cracked products.

TABLE XLVII.—STEUTUBB AND OOTANB RATING OF PARAFFIN HYDROCARBONS.

Compound.	Structure.	Octane rating A.S.T.M., C.F.R.* method.
<b>C<sub>4</sub> Hydrocarbons :</b>		
n-Butane, . . .	CCCC	90-5
isoButane . . .	CCC C	970
<b>C<sub>5</sub> Hydrocarbons:</b>		
n-Pentane . . .	CCCCC	610
isoPentane . . .	CCCC C	91-0
neoPentane . . .	C CCC C	930
<b>C<sub>6</sub> Hydrocarbons:</b>		
n-Hexane . . .	CCCCCC	250
2-Methylpentane	CCCCC C	730
3-Methylpentane	CCCCC C	750
2:3-Dimethylbutane	CCCC CC	930
2:2-Dimethylbutane	C CCCC C	940
<b>C<sub>7</sub> Hydrocarbons:</b>		
n-Heptane . . .	CCCCCC	0
2-Methylhexane	CCCCCC C	450
2:3-Dimethylpentane	CCCCC CC	890
2:2-Dimethylpentane	C CCCC C	930
2:4-Dimethylpentane	CCCCC C C	820
3:3-Dimethylpentane	C CCCC C	840
2:2:3-Trimethylbutane (trip-tane)	C CCCC CC	100+

\* A.S.T.M. = American Society for Testing Materials; C.F.R. = Co-operative Fuels Research.

TABLE XLVIII.—STRUCTURE AND OCTANE BATING OF OLEFIN HYDROCARBONS.

Compound.	Structure.	Octane rating A.S.T.M., C.F.B. method.
Ethene . . .	<b>C:C</b>	<b>81</b>
Propene . . .	<b>C:CC</b>	85
Butene-1 . . .	<b>C:C-C-C</b>	80
Butene-2 . . .	<b>CC:CC</b>	83
Penteno-1 . . .	<b>C:GGCC</b>	82
Pentene-2 . . .	<b>CC:GCC</b>	<b>80</b>
Hexene-1. . .	<b>CrCGGCC</b>	<b>62</b>
Hexene-2. . .	<b>C-C:C-C-C-C</b>	<b>78</b>
Octene-1 . . .	<b>CiCGCC-GCC</b>	35
Octene-2 . . .	<b>C-C:C-C-C-C-C-C</b>	55

TABLE XLIX.—STRUCTURE AND OCTANE BATING OF ISOCTENES.

Compound.	Structure.	Octane rating A.S.T.M., C.F.B. method.
2:4:4-Trimethyl- pentene-1	$\begin{array}{c} \text{C} \quad \text{C} \\   \quad   \\ \text{C}-\text{C} \text{---} \text{C} \text{---} \text{C} \\   \\ \text{C} \end{array}$	86
2:3:3-Trimethyl- pentene-2	$\begin{array}{c} \text{C} \quad \text{C} \\   \quad   \\ \text{C} \text{---} \text{C} \text{---} \text{C} \text{---} \text{C} \\   \\ \text{C} \end{array}$	89
3:4:4-Trimethyl- pentene-2	$\begin{array}{c} \text{C} \quad \text{C} \\   \quad   \\ \text{C} \text{---} \text{C} \text{---} \text{C} \text{---} \text{C} \\   \\ \text{C} \end{array}$	86

TABLE L.—STRUCTURE AND OCTANE BATING OF *cyclo*ARAFFINS.

Compound.	Structure.	Octane rating A.S.T.M., C.F.R. method.
<i>cyclo</i> Pentane.	$\begin{array}{c} \text{CH}_2 \\ / \quad \backslash \\ \text{CH}_2 \quad \text{CH}_2 \\   \quad   \\ \text{CH}_2 \text{---} \text{CH}_2 \end{array}$	85
MethylcycZopentane	$\begin{array}{c} \text{CH-CH}_3 \\   \\ \text{C}^{111} \text{---} \text{C}^{\text{w}} \\   \quad   \\ \text{CH}_2 \text{---} \text{CH}_2 \end{array}$	80
EthylcycZopontane	$\begin{array}{c} \text{CHC}_2\text{H}_{fi} \\ / \quad \backslash \\ \text{C}^{iH_2} \quad \text{C}^a \\   \\ \text{CH}_3 \end{array}$	55

TABLE L.—*continued.*

Compound.	Structure.	Octane rating A.S.T.M., C.F.R. method.
<i>cyc</i> ZoHexane . . .	$\begin{array}{c} \text{CH}_2 \\ / \quad \backslash \\ \text{CH}_2 \quad \text{CH}_a \\   \quad   \\ \text{CH}_2 \quad \text{CH}_2 \\   \\ \text{CH}_3 \end{array}$	77
MothycycZohexane . . .	$\begin{array}{c} \text{CHCH}_3 \\ / \quad \backslash \\ \text{C}^f \text{H}_2 \quad \text{C}^a \\   \quad   \\ \text{C}^a \text{H}_a \quad \text{C}^i \text{H}_a \end{array}$	71
EthylcycZohexane . . .	$\begin{array}{c} \text{CHC}_a\text{H}_6 \\ / \quad \backslash \\ \text{C}^6\text{H}_2 \quad \text{CH}_2 \\   \quad   \\ \text{CH}_2 \quad \text{CH}_2 \\   \\ \text{CH}_1 \end{array}$	41

TABLE LI.—STRUCTURE AND OCTANE BATING OF AROMATICS.

Compound.	Structure.	Octane rating A.S.T.M., C.F.B. method.
Benzene . . .		100+
Methylbenzene (toluene)	$\begin{array}{c} \text{CH}_3 \\   \\ \text{C}_6\text{H}_5 \end{array}$	100+
Ethylbenzene	$\begin{array}{c} \text{CH}_2\text{CH}_3 \\   \\ \text{C}_6\text{H}_5 \end{array}$	97
n-Propylbenzene	$\begin{array}{c} \text{CH}_2\text{CH}_2\text{CH}_3 \\   \\ \text{C}_6\text{H}_5 \end{array}$	96
isoPropylbenzene (cumene)	$\begin{array}{c} \text{CH}(\text{CH}_3)_a \\   \\ \text{C}_6\text{H}_5 \end{array}$	100+

*Tetraethyl-Lead.*

This compound is at present added to most gasolines in the United States to increase their octane ratings, the amounts used varying from 0.5 to 3.0 ml. per gallon in commercial gasolines to as high as 4-6 ml. per gallon in aviation fuels. The susceptibility of gasolines to improvement in octane number by tetraethyl-lead additions varies greatly. Larger increases in octane number occur in the lower ranges, and less as the octane number increases. The susceptibility also differs in different types of hydrocarbons, so that predictions of the exact effects of lead additions are difficult. The lead susceptibility of several gasolines, naphthas, and

synthetic hydrocarbons with different amounts of tetraethyl-lead are given in Table LII.<sup>16a</sup> It should be observed that the effect of a 1 ml. increase in lead decreases as the octane number rises. In the case of the East Texas natural gasoline, the first ml. addition raised the octane number from 70 to 78, while increases of 1 ml. beyond 4 gave increases of only one octane number. Similar effects are evident in the other fuels. Iron pentacarbonyl is a good anti-knock agent, but it lacks requisite stability and its attempted use in continental Europe has not been successful. Aniline and some alkylamines act as anti-detonants in gasoline, but rather large quantities are required.

TABLE III.—LEAD SUSCEPTIBILITIES.  
(A.S.T.M., C.F.R. Motor Method Octane Number.)

	Tetraethyl-lead, ml. per gal.						
	00.	10.	20.	30.	40.	50.	60.
Natural gasoline—Mid-Continent . . . . .	65	74	78	80	82		
Natural gasoline—East Texas . . . . .	70	78	83	88	91	92	93
Straight-run naphtha—Mid-Continent . . . . .	65	73	—	79	81		
Straight-run naphtha—California . . . . .	70	79	83	85			
Conversion naphtha*—Houdry . . . . .	77-78	—	—	91-93			
Conversion naphtha—Reversion . . . . .	77-82	84-87	88-89	90-92			
Conversion naphtha—T.C.C. . . . .	77-80	—	—	92-95	94-97		
Conversion naphtha.—Hydro-f&h-ing . . . . .	75-80	84	86	87			
High-octane hydrocarbons:							
Alkylates . . . . .	92	+0.1*	+0-3*	+0-4*	+0.5*		
Hydrogenated polymers (selective) . . . . .	92-94	103-106	107-109	110-112	113-115		
woOctane . . . . .	100	109	112	114	118		
neoHexane . . . . .	94	107	112	114	117		
woPentane . . . . .	90	99f	103f	105f			

\* Matches woctane plus \* c.c. T.E.L. per gal  
f Estimated from blend data.

*Inhibitors.*

Nearly all marketed gasolines which contain high percentages of cracked products are stabilised by the addition of small amounts of antioxidants or "inhibitors," which retard the formation of olefin peroxides and thus the series of chain reactions otherwise instigated by such peroxides which lead to the formation of gums on storage.

Types of compounds found most effective in inhibiting the deterioration of cracked gasolines are phenols, aminophenols, amines, and the alkyl or aryl derivatives of these three groups. Much experimenting has been conducted to find compounds useful for inhibiting the deterioration of cracked products. Certain hardwood tar fractions containing substantial percentages of alkylphenols have been found to be useful. Butylaminophenols, benzylaminophenol, and phenylenediamines are examples of chemical compounds which have inhibiting action. The amounts of inhibitors necessary properly to stabilise cracked gasolines against deterioration

in storage are extremely small. In the case of the more active antioxidants it is seldom necessary to add more than 0.006% by weight of the gasoline, and often concentrations as low as 0.001% are adequate. These concentrations correspond to about 1 mol of inhibitor to 40,000 mol. of gasoline. The use of inhibitors has greatly advanced the cause of conservation of petroleum resources, since it has obviated the necessity of extensive chemical treatment of cracked gasolines, and conserved valuable anti-knock materials. About 75% of marketed gasolines contain inhibitors.

The production and consumption of motor gasoline in the United States has increased enormously since the beginning of the century. Table LIII gives figures on the production of straight-run and cracked gasoline, and the total gasoline production from 1899 to 1944.<sup>168</sup> «\*<sup>165</sup> The data show that cracked gasoline began to be a factor in the total output in 1914 and that it exceeded the production of straight-run gasoline in 1940.

TABLE LIII.—MOTOR FUEL PRODUCTION  
IN THE UNITED STATES.  
(Thousands of Barrels.)

Year.	Straight-run gasoline.	Cracked gasoline.	Total.*
1899	6,685	0	6,685
1909	12,865	0	12,865
1914	32,735	2,028	35,779
1920	96,951	16,140	124,244
1927	175,000	100,000	316,500
1940	263,584	294,365	616,359
1944	269,482	386,029	744,075

\* Includes all other sources, natural gasoline, benzol, etc.

The figures on world consumption of motor fuel for 1939 are given in Table LIV.<sup>1</sup> These are the latest figures available in January, 1946.

TABLE LIV.—WORLD CONSUMPTION OF MOTOR FUEL.  
(Thousands of Barrels.)

North America.*	
Total . . . . .	686,231
United States . . . . .	655,509
South America.	
Total . . . . .	15,090
Europe.	
Total . . . . .	152,497
Africa.	
Total . . . . .	9,409
Asia.	
Total . . . . .	19,444
Oceania.	
Total . . . . .	15,044
World total . . . . .	798,715

(a) Military consumption not included, except in United States.

(b) Includes related fuels: natural gasoline, benzol, kerosene, alcohol, and synthetic mineral oils from coal and shale.

(c) Includes Central America.

The motor vehicle registrations for 1939 are shown in Table LV.<sup>1</sup> These are the most recent figures available in January, 1946.

TABLE IV.—WORLD MOTOR-VEHICLE REGISTRATIONS, BY GEOGRAPHIC ZONES.

(As at December 31, 1939.)

Zone.	
America, total . . . . .	32,924,187
United States . . . . .	30,615,087
Other America . . . . .	2,309,100
Europe . . . . .	9,463,293
Africa . . . . .	692,974
Asia . . . . .	695,738
Oceania . . . . .	1,200,808
World total . . . . .	44,977,000
Except United States . . . . .	14,361,913

### Gasoline for Airplanes.

Aviation developments had little effect on gasoline until the airplane became a factor as a war machine. In the First World War ordinary gasoline was used in airplane engines, and there was some use of casing head products. The average commercial gasoline in that period is estimated to have been about 50 octane number. Until 1918 no aviation fuel was produced as such. In 1929 the octane numbers of aviation fuels ranged from 65 to 70.<sup>166</sup> In 1930 the United States Army Air Forces specified that aviation gasoline should have 87 octane number<sup>m</sup>; and in 1935 the first army specification for 100 octane aviation fuel appeared.<sup>167</sup> In 1937 fuel for the engines of United States pursuit aircraft was standardised at 100 octane rating.<sup>168</sup> From this time on, development of aviation fuels has been rapid, and the Second World War has seen the production of enormously increased quantities of 100 plus octane fuels and those having ratings far in excess of this value. Prior to December, 1941, the total production of 100 octane aviation gasoline in the United States was somewhat less than 50,000 barrels per day.<sup>166</sup> By the middle of 1944 production had increased to over 500,000 barrels per day,<sup>1M</sup> and super-fuels of well over 100 octane rating in performance characteristics were used in the war effort.

The advantages gained in utilising fuels of 100 plus octane rating are strikingly evident from the data given in Table LVI, which relate to the performance of airplanes similar to the Douglas DC-3 when using fuels of 87, 100, and 100 plus octane ratings.<sup>160</sup>

TABLE LVI.

Octane number.	Cruising speed, m.p.h.	Speed of climb, 50% take-off power, ft. per min.	Ceiling, ft.	Take-off distance, ft.	Payload, lb.
87	176	1,000	22,500	2,400	5,150
100	191	1,425	28,500	2,500	7,400
100 plus	205	1,825	33,500	1,750	9,180

As the octane number increases from 87 to 100 cruising speed increases 15 m.p.h., and as octane exceeds 100 another 14 m.p.h. is gained. The speed of climb in feet per minute increases over 80% from 87 to 100 plus octane fuel, the ceiling rises from 22,500 to 33,500 feet, and the required take-off distance is reduced from 2,400 to 1,750 ft. The payload increases by about 2 tons.

Since airplane engines must function at desert temperatures over 66°c. (160°F.) and stratosphere cold as low as -56°c. (-70°F.) their fuels must have closely specified properties. The distillation range of the gasoline must insure ready volatility and the vapour pressure must be low enough so that vapour lock is not encountered. Most specifications call for boiling ranges of about 38-163°c. (100-325°F.) and 7 lb. Reid vapour pressure. The freezing-point is specified as -60°c. (-76°F.). Special engine-test methods are employed in testing aviation fuels which



employ higher engine speeds, higher jacket temperatures, and greater spark advance than the test for motor gasoline. However, the British Air Ministry Teat Method is substantially the same as the A.S.T.M. motor method.

Aviation fuel is substantially devoid of olefin hydrocarbons and consists of mixtures of iso-paraffin, aromatic and cycloparaffin hydrocarbons obtained from various processes. Those fuels are for the most part blends of gasoline from catalytic cracking, the so-called "conversion" naphthas from aromatisation processes, Moparaffin made by alkylating wobutane with olefins and known as alkylates, and

ethylene. The alkyl aromatics include wopropylbenzene (cumene), and tert-butylbenzene made by alkylating benzene with propylene and wobutylene respectively. AlkylateB have octane numbers varying from about 90 to 95, and high susceptibility to improvement by the addition of tetraethyl-lead. Cumene has a performance rating considerably greater than tfooctane. Among the synthetics, the hydrocarbons of highest anti-knock property ia triptano {2:2:3-trimethylbutano), which can be made by catalytic processes. This hydrocarbon has a performance rating much greater than 100 octane number woctane, and when treated with tetraethyl-lead and used in engines specially designed to utilise it fully, develops from 3 to 4

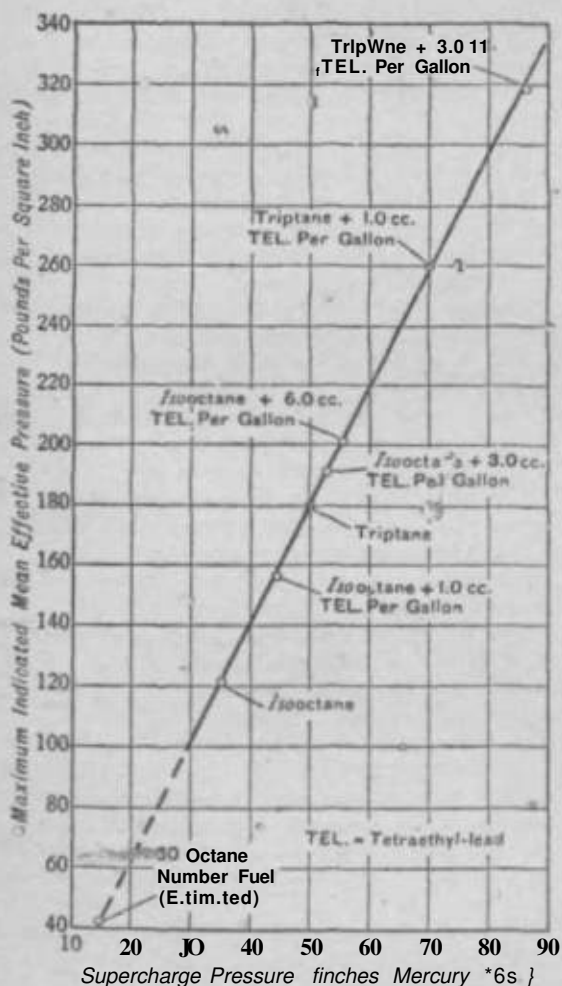

Fig. 37,

aromatics, and special synthetics such as hydrogenated dimers of butylenes. A few straight-run gasolines from naphthenic crudes have sufficiently high octane numbers for use in aviation fuel mixtures, but their percentage of production of 1944 was below five. wopentane is added to practically all blends because of its high octane rating and its volatility to give the fuel a Reid vapour pressure of 7 lb.

The highest octane rating constituents of aviation fuel blends are the so-called alkylates made from wobutene and define, and alkyl aromatics. The alkylates include woctenes made by alkylating wobutene with n- and isobutylenes, neohexane, and 2:3-dimethylbutane made by the interaction of wobutane and

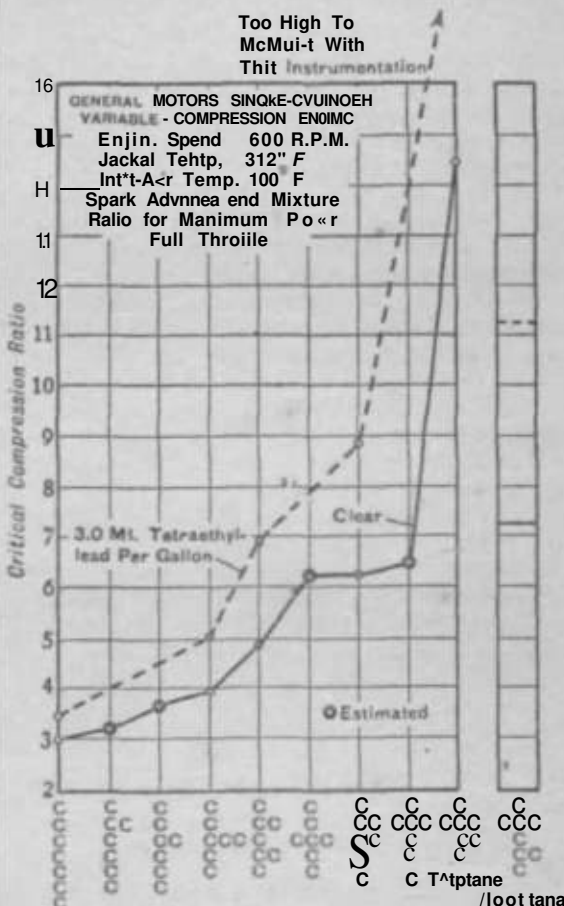

FIG. 38.

times as much power.<sup>181</sup> The graphs in Figs. 37 and 38 show interesting and important comparisons between standard woctane and triptane. Fig. 37 shows data on the performance of a number of fuels in a single-cylinder supercharged test engine. The graph shows a straight line relationship between supercharge pressure and mean effective pressure, the latter being proportional to the power output of the engine. The graph indicates that itooctane develops a mean effective pressure of 120 psi. at supercharge pressure of 35 in. of mercury, while triptane develops 180 psi. at 60 in. of mercury, an increase of 60%. Isooctane with 3 ml. of tetraethyl-lead per gallon develops about 190 psi. pressure at 63 in. of mercury supercharge pressure, while triptane with the same addition of

tetraethyl-lead develops 320 psi., an increase of nearly 70%. These tests were run at 6:5 compression ratio for all fuels.

The knocking characteristics of heptanes and of *isooctane* are shown in Fig. 38 in terms of their critical compression ratios, using a standard set of operating conditions in other respects. This graph shows that the critical compression ratio of triptane is 14-5:1, while that of *isooctane* is 7-3:1. By the addition of 3 ml. of tetraethyl-lead per gallon, the critical compression ratio is raised to 11-3 for *isooctane* and above 16 for triptane.

A twelve-cylinder Allison airplane engine has been operated on a 60% blend of triptane in 100 octane gasoline to give an output of well over 2,500 h.p., although the rated take-off h.p. with the 100 octane gasoline is only about 1,500. Triptane containing tetraethyl-lead has shown four times the power and 25% gain in fuel economy over *isooctane* or 100 octane gasoline. The precise gains depend upon the particular engine employed and the conditions under which it is operated.

Benzene and toluene produced by catalytic dehydrogenation of cycloparaffins are both employed in aviation fuel blends on account of their inherently high anti-knock ratings.

In addition to hydrocarbons, certain other compounds have been tried as components of aviation fuel. Among these are diisopropyl ether, acetone, and methyl ethyl ketone. All of these compounds have high octane numbers and good lead susceptibility, but they give lower power outputs and are unsuitable on account of their solubility in water.

Table LVII shows some typical compositions of 100 octane aviation gasolines.<sup>102</sup>

TABLE LVII.—TYPICAL COMPOSITIONS OF 100 OCTANE GRADE AVIATION GASOLINE.

	1.	2.	3.	4.	5.	6.
Straight - run naphtha, 65-75 octane No., %	30-50	30-50	—	30-40	30-50	30-50
Conversion naphtha, 76-82 octane No., %	—	—	40-60	30-40	—	—
Pentane, 91 octane No., %	10-15	10-15	10-15	10-15	10-15	10-15
neoHexane, 94 octane No., %	—	20-30	—	—	—	—
Octanes, (a) 90-100 octane No., %	40-60	20-30	30-40	30-40	30-50	20-30
Substituted benzenes (6), 90-100 octane No., %	—	—	—	—	—	5-20
Benzene, 100+ octane No., %	—	—	—	—	10-15	—
Tetraethyl-lead, c.c. per gal., max.	30	30	30	30	30	30
Gum inhibitor, lb. per 5,000 gal. max.	10	10	10	10	10	10

(a) Alkylates, alkylate gasolines, hydrogenated polymers.

(b) Cimene, *isobutylbenzene*, etc.

An important development in increasing the efficiency of airplane engines involves the in-

jection of small quantities of water or alcohol-water mixtures.<sup>113</sup> Remarkable burst<sup>1</sup> of power have been shown both in take-off and during flight when these mixtures have been injected, particularly in supercharged engines. The effects of alcohol-water injection are probably due to a combination of high latent heat of vaporisation and some function of specific heat. The cooling of pistons, valves, spark plugs, and the cylinder head itself suppresses detonation and pre-ignition and permits higher power outputs. Carbon deposits are much softer and more easily removed.

Apparently a number of different alcohols can be used, tests having been made with methyl, ethyl, and *isopropyl*. Such alcohol supply B.Th.U.'s. Fifty-fifty alcohol-water mixtures appear to be most economical.

The control of pressure rise and detonation shock by alcohol-water injection may enable the manufacture of lighter high-compression engines. This may be useful in the design of light airplane engines. In the case of the engines on ground vehicles employing supercharging, alcohol-water injection will enable the engine to consume more air at the same engine speed.

The use of jet propulsion and gas turbines for airplane engines is focusing attention on the type of fuel best suited for these purposes. At the present time (1945), the fuel used in jet planes is kerosene, which must have a low freezing-point for suitable operation under stratosphere conditions with temperatures below -50°C. (-60°F.). While consumption in jet-propelled planes is higher than in gasoline-powered reciprocating engines, increased speeds more than compensate for increased fuel consumption in fighter planes. Off-setting the disadvantage of high fuel consumption, jet-propelled planes have a number of advantages. They have speeds much greater than that of any plane driven by a reciprocating engine and propeller. Speeds of 700-800 m.p.h. have been attained. They have a high degree of manoeuvrability at high speeds. Vibration is negligible, eliminating one cause of pilot fatigue. They are ready for take off 30 seconds after starting the engine, and function<sup>1</sup> and use less fuel at high altitudes. The planes have fewer controls and instruments, and the engine is lighter per h.p. than the reciprocating engine. The jet engine is simple and easily maintained.

#### F1 and V2 War Weapons.

The German flying bomb known as the V1<sup>164</sup> was driven by a jet reaction engine of simplest design, the only moving parts of which were flap valves in a forward grid. Gasoline was injected from 1/8-in. openings into a compressed air chamber in which combustion was started by a spark which was cut off when the engine was warmed sufficiently so that the fuel-air mixture would pre-ignite. When the pressure in the combustion chamber dropped below a certain point, the flap valves were forced open by the forward air pressure due to the bomb's velocity, and a new charge of air was admitted. The frequency of the explosions was about 45 per second or 2,700 per minute. The gasoline tank held 180 gallons, and since the consumption was about 1 gallon per mile in a time of 10 seconds, the

maximum travel was 180 miles in a time of 30 minutes. The indicated fuel consumption per mile was about equal to that of a fully loaded bomber the engines of which developed 6,000 h.p. The bomb speeds were between 350 and 400 m.p.h. and they flew at an average elevation of 2,300 ft.

The V2<sup>1as</sup> weapon was essentially a rocket in that it contained both fuel and oxygen necessary for its flight and was not dependent upon outside air. The projectile was launched vertically from a hard surface, such as a concrete platform. Two spherical containers held 7,500 lb. of alcohol and 11,000 lb. of liquid oxygen, respectively, which, were injected into a combustion chamber where they were ignited electrically. Concentrated hydrogen peroxide and calcium permanganate solutions were added to the combustion mixture to control the rate. The initial thrust amounted to about 26 tons. After about 60 seconds of vertical flight the angle was shifted to 45° to achieve a maximum trajectory by such means as a time mechanism, or barometric or radio control. As fuel was consumed, the rocket became lighter and speeded up, owing to the constant thrust and decreased air density. The range was about 200 miles, with a maximum elevation of over 60 miles and a maximum speed of 4,500 m.p.h. Since the speed when re-entering the lower air strata was over 1,000 m.p.h., it was ultrasonic, and the bomb could not be heard before it had struck. One projectile used up 8,000 lb. of fuel in its flight, the time between launching and impact being about 4 minutes. This amount was equivalent to the 100-octane aviation fuel which would fuel a four-engine bomber loaded with 2-5 tons of bombs on a 5-hour mission. \*

### Diesel, Fuel.

Diesel fuels are those used in engines in which the fuel is directly injected into the cylinder and atomised prior to ignition and combustion. Four types of engines fall into this category: in the first, air is highly compressed and fuel injected at the end of the compression stroke;

compression ratios vary from 13:1 to 20:1. In a second type a hot surface is used to assist evaporation and ignition of the fuel; compression ratios are from 7:1 to 10:1. A third type depends upon the injection of preheated fuel-air mixtures which are compressed and ignited by a spark; compression ratios in this type are 4:1. A fourth type compresses air at a low ratio of from 5:1 to 7:1, the fuel being injected near the end of the compression stroke and ignited by an electrical spark.<sup>168</sup>

The diesel engine was originally designed to burn coal dust, but it did not prove successful operating on this type of fuel. The engines now in use burn oils of widely varying characteristics of the nature of kerosene to heavy residual tars from both crude petroleum and coal. In the engines which use no spark ignition the auto-ignition properties of the fuel are of paramount importance. As a rule the more paraffinic hydrocarbon fuels ignite more readily and are therefore more suitable for these engines, although ignition properties are not related to the combustion properties of the fuel. High speed diesel engines are used in buses, trucks, many ships, and locomotives. These operate smoothly on paraffinic gas-oil distillate boiling from about 200° to 360°C. (392° to 662°F.). However, blends of such oils with cracked products of the same boiling range, such as pressure distillate bottoms or recycle stocks, can be used satisfactorily. The flash point is usually specified at 66°C. (150°F.) minimum to avoid danger in handling. Suspended particles of water, sand, dust, iron, iron oxides, or fibres, should be absent to avoid abrasion and possible plugging of small injection nozzles.

In the larger and heavier low-speed diesel engines employed in stationary power plants, much heavier and more viscous fuels can be used, such as residual fuels, oils, tars, and asphalts, since these engines operate at higher temperatures and higher compression ratios, and under heavier and more uniform loading.

Committee D-2 of the A.S.T.M. has classified diesel fuels according to viscosities as shown in Table LVHI.

TABLE LVHI.—DIESEL FUELS.\*

Designation	For use in aircraft, r.p.m.	Flash (closed cup).		Cetane number.	Viscosity, Saybolt sec. at 88°F. (100°F.).	B.S. and W.	Max. sulphur, wt. %.	Carbon residue, wt. %.	Max. ash, wt. %.	Distillation.	
		°F.	°C.							90%.	End pt.
1-D	over 1,200	33	100	40	—	0.05	M	0.05-10	0.01	550°F.	
2-D	1,200	60	140	45	320-45-5	0.05	10	0.25-10	0.01	650°F.	700°F.
a-D	500-1,200	60	140	35	65	0.10	15	0.25	0.02	—	—
4-D	under 500	60	140	30	140	0.50	20	2.0	0.10	—	—

\* Co-operative Fuel Research, A.S.T.M. Classification; Committee D-2; 1044.

Diesel fuels are rated by their spontaneous ignition temperature, determined by dropping the fuel into a heated crucible and noting the temperature at which ignition occurs. The fuel with the lowest ignition temperature is best

suited for use in high-speed engines. Direct determinations of ignition properties are also made in engines of standard design by measuring either the critical compression ratio at which ignition occurs or the ignition lag. The fuels are

compared with mixtures of 1-methylnaphthalene and either cetene or cetane, cetene being used in Great Britain and cetane in the United States. The percentage of either the olefin or the paraffin hydrocarbon present in the blend which shows the same ignition properties as the unknown fuel gives the cetene or cetane number respectively (v. Vol. VIII, 640c). For most diesel engines fuels of 35 cetane number and higher are satisfactory.

The cetane numbers of distillate diesel fuels from crude oils vary between rather wide ranges, depending largely upon the predominance of paraffin or cyclic hydrocarbons respectively. The cetane numbers for several straight-run diesel fuels from American fields are shown in Table LIX.<sup>17</sup>

TABLE LIX. CETANE NUMBERS FOR STRAIGHT-RUN DIESEL FUELS FROM U.S. CRUDE SOURCES, ABBREVIATED GEOGRAPHICALLY.

	Types of crude.*			Cetane No.
	P.	N.	A.	
1. Pennsylvania . . . . .	85	9	6	65
2. Pennsylvania . . . . .	85	9	6	62
3. Kentucky . . . . .	73	12	15	52
4. Michigan . . . . .	83	9	8	68
5. Michigan . . . . .	66	15	19	56
6. Indiana . . . . .	74	12	14	52
7. Illinois . . . . .	74	12	14	52
8. Mid-Continent . . . . .	75	12	13	55
9. Kansas . . . . .	69	14	17	59
10. Oklahoma . . . . .	75	12	13	56
11. Louisiana . . . . .	89	7	4	63
12. Gulf Coast . . . . .	75	12	13	58
13. South Texas . . . . .	47	21	32	33
14. South Texas . . . . .	45	22	33	32
15. East Texas . . . . .	75	12	13	65
16. East Texas . . . . .	70	14	16	57
17. West Texas . . . . .	83	9	8	64
18. West Texas . . . . .	69	14	17	48
19. West Texas . . . . .	67	15	18	45
20. New Mexico . . . . .	58	17	25	48
21. Rocky Mountain . . . . .	73	12	15	51
22. Wyoming . . . . .	80	10	10	68
23. Wyoming . . . . .	73	12	15	59
24. California . . . . .	69	14	17	47
25. California . . . . .	64	16	20	45
26. California . . . . .	56	18	26	41

\* The type of crude is defined by stating the approximate amounts of the different types of hydrocarbons in the straight-run diesel fuel.

P=Paraffins, in %.  
N=Naphthenes, in %.  
A=Aromatics, in %.

A number of formulas for calculating indices of ignition quality have been proposed. These principally used relationships between specific gravity, average boiling-point, aniline point, and viscosity.

To increase the ignition properties of diesel fuels, use is made of special additives in amounts of 1-5%.<sup>187</sup> These compounds frequently render a fuel suitable for diesel use, which is otherwise below ignition specifications. A number of compounds have been tried as diesel fuel additives. These are listed below:

(i) *Aliphatic Hydrocarbons*.—Examples of this class of ignition accelerators are acetylene, allylene, divinylacetylene, and butadiene.

These compounds are relatively ineffective as ignition promoters when compared with the

nitrates and peroxides, and consequently must be added in reasonably large concentrations.

(ii) *Aldehydes, Ketones, Ethers, Esters, etc.*—These compounds may be exemplified by furfuraldehyde, acetone, diethyl ether, ethyl acetate, nitroglycerin, and methyl alcohol.

They have an order of effectiveness slightly greater than that of the aliphatic hydrocarbons; however, diethyl ether is excellent for starting, whereas the other compounds are not.

(iii) *Metal Derivatives*.—Some examples of this group are barium nitrate, copper oleate, manganese dioxide, potassium chlorate, and vanadium pentoxide.

In general, the effectiveness of these compounds is just slightly less than that of the aliphatic hydrocarbons and the peroxides.

(iv) *Alkyl Nitrates and Nitrites and Nitro-compounds*.—Typical of this group are ethyl nitrate and ethyl nitrite.

This class of compounds is highly effective in promoting ignition in the diesel engine, being exceeded only by certain of the peroxides.

(v) *Aromatic Nitro-compounds*.—These may be exemplified by nitrobenzene or nitronaphthalene. Their action is essentially the same, but they are less effective than the ethyl nitrates because of the stability of the aromatic ring.

(vi) *Nitration*.—Nitration of the fuel produces many compounds to which the nitrate group is attached. In general, they are less effective than the alkyl nitrates because of the lower ratios of the weight of the nitrate group to those of the hydrocarbon portion of the compound.

(vii) *Oximes and Nitroso-compounds*.—Examples of this group are formaloxime and nitrosomethylmethane. In general, these compounds have an effectiveness approximately halfway between that of the aliphatic hydrocarbons and alkyl nitrates.

(viii) *Oxidation and Oxidation Products*.—Oxygen and ozone are two typical examples of the class of materials included in this section. Their effectiveness is relatively low and their action is explained by the fact that the rate of oxidation is increased by the greater concentration of oxygen.

(ix) *Peroxides*.—Acetone peroxide is the most prominent example of the peroxide class. It is slightly more effective than the alkyl nitrates, and therefore heads the list so far as effectiveness is concerned.

(x) *Polysulphides*.—A representative of the polysulphide group is diethyl tetrasulphide. In general, the polysulphides have an effectiveness on the order of the oximes.

(ix) *Unclassified*.—This section includes various materials upon which information is insufficient to justify a separate section. Some of these are the halogens, sulphur and certain sulphur compounds, and the amines. The sulphur and sulphur compounds have an action similar to that of the polysulphides, and all compounds with the exception of the thionitrates and thionitrites have an order of effectiveness similar to that of the polysulphides. The thionitrates and thionitrites, along with certain of the chloronitro compounds, e.g., trichloronitromethane, are so effective that they rank with acetone peroxide.

The compounds principally employed as ignition accelerators are acetone peroxide, ethyl nitrate, and isoamyl nitrate. The effect of adding different alkyl nitrates to a diesel fuel is shown in Table LX.<sup>167</sup>

TABLE LX.—CETANE IMPROVEMENT FOR VARIOUS ALKYL NITRATES. When 1-5% is added\* to a base fuel of 44 cetane number.

Alkyl nitrate.	Cetane number, base fuel plus 1-5% alkyl nitrate.	Increase in cetane number.
Mixed amyl nitrates . . . . .	63	19
w-Amyl nitrate . . . . .	67	23
n-Butyl nitrate . . . . .	63	19
isoPropyl nitrate . . . . .	61	17
Octyl nitrate . . . . .	03	19
cyctoKexyl nitrate . . . . .	66	22
sec.-Hexyl nitrate . . . . .	62	18
sec-Amyl nitrate . . . . .	64	20
isoAmyl nitrate . . . . .	65	21
n-Hexyl nitrate . . . . .	64	20

The diesel engine was proposed as a means of reducing fuel costs, since diesel fuels are less expensive than gasoline. However, only limited amounts of oils are suitable for use in light diesels, and these are oils which are in demand for charges to both thermal and catalytic cracking, and for domestic heating.<sup>168</sup> Increased demands for these oils will cause a price increase so that some advantage will be lost. The diesel engine is of heavier construction than the gasoline engine and this initial cost must be considered in estimating any overall advantage.

The h.p. of diesel installations in the United States as at January 1, 1939, is given in Table LXI.<sup>169</sup>

TABLE LXI.—U.S. DIESEL HORSE-POWER INSTALLED, BY USES.

Industry.	Horse-power.
Tractors (agricultural and industrial)	2,136,000
General industry . . . . .	1,893,575
Marine . . . . .	1,813,600
Petroleum industry . . . . .	787,165
Mobile (except railroads) . . . . .	771,100
Municipal light plants . . . . .	650,000
Public utilities . . . . .	600,000
U.S. Navy and Coast Guard . . . . .	488,100
Railroads . . . . .	393,800
Mines and quarries . . . . .	301,500
Cotton gins . . . . .	226,800
Ice plants . . . . .	219,800
Irrigation and drainage . . . . .	202,000
Water works . . . . .	198,100
Government institutions . . . . .	141,725
Building industry . . . . .	43,430
Total U.S. installations . . . . .	110,665,685
Cumulated exports . . . . .	610,800
Total U.S. diesels in use . . . . .	11,276,485

Kerosene is also used for power purposes as an internal combustion engine fuel, and the properties required for this use are essentially different from those required in kerosene used as an illuminant.<sup>169</sup> The principal types of kerosene engines are the hot bulb and the spark ignition engines. In the former type of engine, kerosene should be employed with about 30% distilling below 200°C. (392°F.), and a final boiling-point of 300°C. (572°F.). As to anti-knock value, there should be a balance between a highly paraffinic kerosene which may cause too early ignition and a highly aromatic kerosene which causes a delayed ignition.

In the spark ignition engine the kerosene used should have at least 50% distilling below 200°C. (392°F.) and should be highly aromatic or aromatised by addition of aromatic concentrate to insure a relatively high anti-knock value.

**Tractor Fuel.**

A fuel largely used for farm tractors in the United States is a distillate corresponding to the higher boiling-point range of gasolines and the lower boiling range of kerosenes. While many tractors are equipped with diesel engines, a high proportion are of the spark ignition type and use these lighter distillates. The principal reason for using this type of fuel instead of gasoline is one of cost, since the tractor fuels are not taxed in the United States, and this factor is mainly responsible for the low cost per acre of ploughing.<sup>170</sup>

**Gasoline Substitutes.**

An oil shortage, brought about by the Second World War, caused a gasoline stringency in many parts of the world, particularly in Europe. This called forth many proposals for the manufacture of gasoline from other combustible materials such as coal, oil shale, lignite, and peat; for the substitution of alcohol and the use of natural gas, methane from sewage, acetylene, hydrogen, ammonia, and producer gas. So far, all of the proposed substitutes have been generally more costly and less efficient in internal combustion engines, but their use has increased in some sections of the world due to sheer necessity. War needs have accentuated the demands for motor fuels and have stimulated processes for the production of substitute gasolines, particularly in European countries, which with the exception of Russia are poorly supplied with petroleum.

The hydrogenation of coal by the Bergius process, which operates at temperatures of 480°C. (900°F.) and pressures of 200 atm. or higher, produces the largest amount of non-petroleum gasoline in Europe. In 1940 the coal hydrogenation process produced 24,225,000 barrels of gasoline in Germany.<sup>171</sup> The Fischer-Tropsch process in which carbon monoxide is hydrogenated in the presence of catalyst produced 11,135,000 barrels in the same year.<sup>171</sup> Later figures are not available due to wartime restrictions.

Large amounts of benzol and light coal-tar distillates were used in Germany to increase the available supplies of motor fuel, the amount in 1940 being over 6,000,000 barrels, while 600,000

barrels were used in France and 300,000 in Belgium.<sup>171</sup> Benzol has an anti-knock rating better than twoctane and is a valuable constituent of gasoline blends.

Shale oils in 1940 accounted for about 10,000,000 barrels of gasoline for European consumption. Gasolines from this source are highly olefinic and require chemical treatment and the use of inhibitors to stabilise them.

The use of compressed hydrocarbon gases is common in Europe. For automotive transportation, gases are used in flexible balloons under low pressure, and also in cylinders under pressures from 75 to as high as 5,000 psi. The higher the pressure the heavier the cylinders required, and considerable weight is added to the automotive vehicle. However, the use of hydrocarbon gases in this manner is extensive. Propane-butane mixtures operate with good efficiency, these mixtures being a by-product not only of natural gas and petroleum refining, but of the coal hydrogenation and Fischer-Tropsch processes used in Europe.<sup>172</sup> Some data in connection with the relative fuel values of compressed gases in relation to gasoline are shown in

Table LXII.<sup>171</sup>

TABLE LXII.—COMPRESSED GASES IN RELATION TO GASOLINE.

Gas.	Cylinder weight, lb.	Pressure, lb. per sq. in.	Gas, lb.	Gasoline equivalent, U.S. * gal.
Propane-butane	117	75-150	100 0	180
Methane . . .	115	8,000-5,000	28-0	456
City gas . . .	155	3,000	12-6	1-8

Ethyl alcohol is being used in a number of countries as an internal combustion engine fuel to supplement) supplies of gasoline. The most frequent use is in blends with ordinary gasoline, although in localities where gasoline is expensive alcohol is sometimes used alone. The source of alcohol is most commonly the fermentation of vegetable materials such as grain, particularly corn, although its production from the fermentation of potatoes, beets, black strap molasses and bagasse from cane sugar manufacture is also practised. Alcohol is produced commercially from ethylene obtained from cracking process gases. Ethylene is dissolved in sulphuric acid of 90% or higher concentration to form mono- and di-ethyl sulphates. The mixed esters are hydrolysed to produce ethyl alcohol, diethyl ether, and small amounts of other products. The reactions involved in this process are given below.<sup>173</sup>

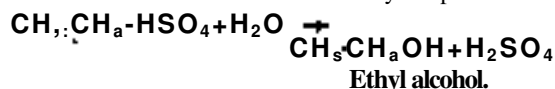
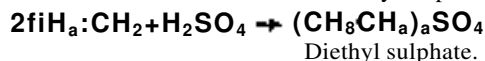
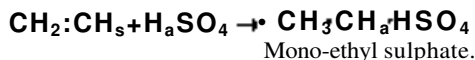

The mono-ethyl ester is more readily hydrolysed than the diethyl compound.

The amount of alcohol used as motor fuel is difficult to determine. The amounts used annually in certain European countries prior to the outbreak of the Second World War have been estimated as follows<sup>171</sup>:

CABLE LXIII.

Country.	Alcohol (bands).
Germany . . . . .	4,000,000
France . . . . .	1,600,000
Hungary . . . . .	80,000
Poland . . . . .	100,000
Italy . . . . .	345,000
Lithuania . . . . .	50,000

In China the need for motor fuel during the Second World War led to the cracking of vegetable oils to produce gasoline and diesel fuel. Such oils as tung, rape seed, cotton seed, soybean, and peanut were tried, with the greatest emphasis on the use of tung oil. The oils were destructively distilled with cracking of vapours, cracked liquid phase in the presence of catalysts such as aluminium chloride, lime, magnesia, and caustic soda, and saponified with later cracking of the soap and recovery of glycerol. Yields of 200°o. (392°F.) end-point gasoline distillate of from 16 to 30% were obtained, with an average of about 20%, based on the original vegetable oil. The Gasoline distillate contained acrolein and was quite unsaturated, losses from 15 to 78% being encountered on treatment with sulphuric acid. The A.S.T.M. octane number was about 60.

Countries deficient in gasoline supplies are using produce" gas to power their vehicles.<sup>174</sup> Many types of solid fuels are used in gas generators, either connected to or integral with the engines. Table LXIV Aists some of these according to source.

So extensive has the use of producer gas become that it has resulted in many localities in a shortage of the solid fuels themselves. In 1938, Europe had about 9,000 trucks and buses in operation which depended upon producer gas for their propulsion, while in 1941 there were 450,000 such vehicles registered, a 50-fold increase. In Russia the use of wood for the generation of producer gas is discouraged because it is expensive and low in energy content. It is estimated that one tractor consumes annually the wood of 2J acres of forest, and although Russia has large timber resources, this would mean depletion of reserves. Charcoal is recommended because it is easily handled, has high heating value, and yields no resinous substances. Good charcoals have been obtained from dry distillation of wood wastes, pine pitch, stumps, windfalls, and slabs. Peat, sapropoles, and shales have been used directly. Semi-coked peat has been used effectively, and the distillation of peat tar which gives liquid fuel and lubricants reduces costs considerably. In some parts of Russia brown coal is used in gas-generating tractors. The cost in these installations is said to be about one-sixth that of gasoline, one-third that of wood, and from one-half to one-third that of charcoal.

TABLE LXI.

- Wood.*
1. Charcoal.
  2. Wood (green or d\$ed).
  3. Sawdust.
  4. Shavings.
  5. Chips.
  6. Waste.
  7. " Generator."
- Peat.*
1. Peat dried).
  2. Peat (carbonised).
  3. Peat coke.
  4. Peat (briquet).
- Coal.*
1. Brown.
  - 2.°Lignite.
  3. Anthracite.
  4. Coke (low temperature).
  5. Coke (high temperature).
  6. Coke (breeze briquet).
- Miscellaneous.*
1. Corn cobs.
  2. Flax waste.
  - % Lignin.
  4. Grain wheat.
  5. Coffee, husks.
  6. Nut shells
  7. Cotton seed.
  8. Sugar cane (branches).
  9. Grape seeds.
  10. Straw.

Apart from the inconvenience of charging, starting, and ash disposal, producer-gas propelled vehicles attain a maximum speed of about 35 m.p.h. on level stretches and can seldom overcome more than a 7% grade, while loaded trucks have difficulties with, still lower grades. The question of carbon monoxide poisoning has made necessary the imposition of regulations concerning the operation of generators.

As a comparison of petroleum products with various substitute materials, the data in Table LXV show on a heat-content basis the relative volumes of various substitutes in equivalent barrels of ordinary motor gasoline.<sup>17\*</sup>

TABLE LXV.

	Equivalent barrels 60° A.P.I.
One barrel:	
Benzol . . . . .	107
Natural gasoline . . . . .	0.941 (assuming 75° A.P.I. natural gasoline).
Butane . . . . .	0.823
Propane . . . . .	0.730
Ethyl alcohol . . . . .	0.671
Methyl alcohol . . . . .	0.507
One thousand cubic feet:	
Natural gas . . . . .	0.219 (assuming 1,150 B.Th.U. per cu. ft.).
Methane . . . . .	0.196 (assuming 1,009 B.Th.U. per cu. ft.).
Manufactured gas (city gas) . . . . .	0.103 (assuming 537 B.Th.U. per cu. ft.).
Producer gas . . . . .	0.019 (assuming 100 B.Th.U. per cu. ft.).

KEROSENE.

The word " kerosene " was originally a trade name for lamp oils produced from coal and oil shale and is an alternative name with paraffin oil (British) and coal oil (American). Prior to the commercial production of these oils, many types of vegetable and animal oils and fats were used for artificial lighting, and explorations have shown that wick-fed lamps using these oils were common many thousands of years ago in Egypt.<sup>176</sup>

Kerosene was the mainstay of the petroleum industry in the United States for about half a century, and all possible fractions were blended to produce a maximum yield. Table LXVI shows the status of kerosene for the first four decades of the twentieth century.<sup>176</sup>

TABLE LXVI.

Year.	Percentage yield of kerosene from crude.	Annual production (millions of barrels).
1899	67.6	33
1904	48.3	67
1909	33.0	60
1914	24.1*	63
1919	15.4	65
1924	9.3	67
1929	5.8	53
1935	6.8	65.8
1942	5.2	70
1944 <sup>177</sup>	4.8	78.5

Kerosene is essentially a straight-run distillate, the boiling range lying between gasoline and gas oil, although it may overlap both of the latter products. The initial boiling-point is sometimes as low as 128°c. (262°F.), and as high as 180°c. (356°F.), while its final boiling-point may vary from 235° to 330°c. (455° to 572°\*.) Like other straight-run products, kerosene distillates contain paraffins, naphthenes, and aromatics, and their physical and chemical properties depend upon the proportions, structures, and boiling range of these hydrocarbon groups. Treatments of kerosene distillates to improve their burning properties are aimed primarily at the removal of aromatic hydrocarbons and a certain amount of the naphthenes.

The United States Bureau of Standards, working under an American Petroleum Institute Research Project, has separated a number of hydrocarbons boiling in the lower portion of the kerosene range, i.e., from 145° to 230°c. (293° to 446°o.).<sup>178</sup> These include n-nonane, n-decane, iwdecanes, mesitylene, pseudocumene, hemimelhtene, propylbenzene, ethyltoluene, butylbenzene, methylpropylbenzene, and naphthenes. Other compounds isolated from an aromatic fraction after freezing and centrifuging out normal paraffins were: 1:2:3:4-tetramethylbenzene, naphthalene, 5:6:7:8-tetrahydronaphthalene, 2-methyl-5:6:7:8-tetrahydronaphthalene, 1-methyl-5:6:7:8-tetrahydronaphthalene, 2-methylnaphthalene, 1-methylnaphthalene. These hydrocarbons represent about 20% of the distillate fraction analysed. The remainder of the



compounds are paraffins and naphthenes which have not yet been isolated and identified as individual compounds. Other workers have found dimethylnaphthalene, ethylxylene, and *p-cymene*. The untreated kerosene distillates may contain as high as 40% of aromatic hydrocarbons. Both sulphur and nitrogen compounds are present. Total sulphur ranges from 0.02 to 0.1% and nitrogen compounds are present in distillates from nitrogen-containing crudes, such as those from California, Galicia, Rumania, Russia, and Japan. Several types of organic acids occur; paraffin carboxylic, monocyclic, and bicyclic acids being present in amounts varying from 0.1 to 2.0%.

Specifications for kerosene are closely bound with the design of the lamps in which it is to be used. The specific gravity of most kerosene varies from about 0.775 to 0.850 (51 to 35 A.P.I.). Colour varies from water-white to a light green or yellow, although colour alone is no indication of burning properties. The flash point is the most important property of kerosene from a safety standpoint, since this test indicates the temperature at which explosive quantities of vapour are formed. Flash-point specifications vary from about 24° to 66° (75° to 150°F.).

The viscosity of kerosene is an important property which determines the rate of feed through the wick. The most important tests for kerosene are those using lamps, which indicate the suitability of the product for use as an illuminant. In these tests the developed candle power of the oil is determined per unit of oil consumed, the wick is examined after a test to notice deposits which may encrust it and interrupt the flow of kerosene to the flame, and the chimney is examined for deposits which lower the luminosity. The candle power developed by a given lamp depends upon the unit luminosity of the frame and the height which can be used without smoking. A kerosene with a high percentage of aromatic and naphthenic hydrocarbons gives a more intensely luminous flame but smokes sooner as the flame is increased, while a highly paraffinic kerosene gives less light per unit flame area but permits a higher flame before smoking occurs.

The smoke point of kerosenes is determined in small test lamps, the flame being turned up until smoke appears at the tip when the height of the flame is noted as the smoke point. By this test an idea of the hydrocarbon composition of the oil is obtained and an indication of its smoking tendencies in ordinary flat wick and circular wick lamps. A paraffinic kerosene will give a high flame without smoking, while one containing a high percentage of aromatic and naphthenic hydrocarbons will give a much lower flame before smoke appears.

Table LXVII shows results obtained with a paraffinic kerosene to which different percentages of a highly aromatic kerosene extract were added.<sup>6</sup>

Highly refined and good burning kerosenes are needed not only for domestic lighting, but in railway signal lamps, lighthouses, and in incubators and brooders, places where any interruption of the illumination or heating is

TABLE LXVII.

% paraffinic kerosene.	% aromatic extract.	Smoke point, mm.
100	0	32
95	5	29
90	10	26
85	15	22
80	20	20
70	30	14
60	40	10

especially disastrous. Kerosene heating and cooking stoves are still widely used. For these special uses the flash point should be high to eliminate dangers of explosion, and the viscosity should be low to insure uniform feed rates, even though the oil level varies considerably. A heavy kerosene known as "mineral seal oil" is used as a coach and ship illuminant, and as a gas absorption oil.

#### GAS OILS, FUBNAOE OILS, AND RESIDUAL FUELS.

Gas oil is the term broadly applied to petroleum distillates which distill between kerosene and lubricating oils. The boiling range of such distillates varies widely, the initial boiling-point being sometimes as low as 180° (356°F.) and the end point being frequently as high as 450° (842°F.). Most gas-oil distillates overlap the higher boiling range of kerosene, and the amount recovered from various petroleum depends upon the method of distillation and the amount of kerosene produced. The term gas oil has been broadly applied to these distillates because of their use in carburetting water gas to raise its heating and illuminating value. However, they are widely used as domestic fuel oils and are in demand as cracking-plant charging oils, particularly in catalytic cracking operations.

In the gas industry, gas oils are cracked at high temperatures of the order of 15-775°C. (1,337-1,427°F.) to produce gas mixtures which are blended with water gas to give the required heating and illuminating characteristics.<sup>179,180</sup>

Gas-oil distillates vary in specific gravity from about 0.9042 to 0.8498 (A.P.I. gravity 25-35), although most are included in the range from 0.8762 to 0.8498 (A.P.I. gravity 30-35). They are usually too viscous for satisfactory lamp oil and not viscous enough for lubricating oils. Many contain paraffin wax and show a relatively high solidification temperature. They vary in colour from a straw yellow to dark red, and some exhibit greenish or bluish fluorescence. Some made by the distillation of asphaltic crude oils contain colloidal asphaltic particles which precipitate on standing or coagulate in contact with a small amount of sulphuric acid.

Limited data on the hydrocarbons present in gas oils show varying amounts of aromatics, naphthenes, and paraffins but generally no olefins.<sup>181</sup> High carbon to hydrogen ratios in heavier gas-oil fractions combined with unsaturated tests with halogens indicate that olefin

hydrocarbons are absent, and lead to the conclusion that the hydrocarbon (present are polycyclic aromatics or their partially or completely hydrogenated derivatives. Typical compounds which are probably present in gas-oil fractions are acenaphthene, b.p. 277°c. (530°F.), fluorene, b.p. 295°c. (663°F.), a completely hydrogenated phenanthrene, b.p. 374°c. (5264r.), and paraffins such as isomeric triacontanes.

In Table LXVIII the names and formulas of hydrocarbons indicated in gas oils are given, which show that in all cases the ratio of carbon to hydrogen is greater than that required by the formula  $C_nH_{2n}$ , the overall formula for either naphthenes or mono-olefins.

TABLE LXVIII.

Hydrocarbon.	Formula.
Acenaphthene . . . . .	$C^{10}H^8$
Fluorene . . . . .	$C^{14}H^{10}$
Perhydrophenanthrene . . . . .	$C^{14}H^{12}$
Perhydrochrysene . . . . .	$C^{18}H^{14}$

In rating distillates for their value in improving water gas or other low heating-value gases, the most direct method involves passing the gas oil through a cracking tube at a temperature of about 750°c. (1,382°F.) under atmo-

TABLE LXIX.—ANALYTICAL DATA OF THREE SAMPLES OF GAS OILS.

	1.	2.	3.
Colour . . . . .	Dark brown.	Brownish-green.	Dark brown.
Sp.gr. . . . .	0.8493	0.8745	0.8628
A.P.I.gr. . . . .	35.1	30.3	32.5
Hydrocarbon analysis (% by vol.): *			
Paraffins . . . . .	73.0	44.6	45.0
Olefins . . . . .	14.0	4.4	2.60
Naphthenes . . . . .	9.0	43.0	1.90
Aromatics * . . . . .	4.0	8.0	1.00
Distillation test:			
Initial b.p. . . . .	191°c; 375°F.	190°c; 374°F.	189°c; 372°F.
End b.p. . . . .	404°c; 760°F.	379°c; 714°F.	436°c; 817°F.
% by vol.:			
Lamp oil, 150-315°c. (302-599°F.) . . . . .	78.8	85.5	60.0
Heavy oil, above 316°c. (f 99°F.) . . . . .	20.9	14.3	38.0
Cracking test:			
Optimum temperature . . . . .	718-750°c. 1,330-1,390°F.	742-760°c. 1,380-1,410°F.	742-769°c. 1,380-1,425°F.
Efficiency, B. Th. l. f. per gal. . . . .	104,000	96,500	101,500
Cu. ft. oil gas per gal. . . . .	59.5	60.5	58.0

spheric pressure and determining the volume of gas produced, and its heating value. Table LXIX includes the properties and the results of cracking tests on three typical gas-oils, which indicate that the oil containing the highest percentage of straight-chain hydrocarbons produced the highest yield of heat units per gallon of oil cracked.<sup>180</sup>

There are no well-established specifications for gas oils involving gravity, flash point, viscosity, hydrocarbon composition, and heating value. Some specifications require less than 0.5% total sulphur in order to reduce the amount of purification necessary in the carburetted gas.

**Furnace Oils.**

Gas-oil distillates are also in demand as light furnace oils for domestic heating and as diesel fuels. In 1934 about 54,000,000 barrels of distillate fuels were used for domestic heating in the United States, and in 1941 the figure had increased to 121,000,000 barrels. The consumption of these distillates as diesel fuels in 1934 was 12,700,000 barrels, and in 1941, 27,700,000 barrels.<sup>182</sup> The recent large increase

in catalytic cracking to make high octane aviation stocks has increased the demand for gas-oil distillates to be used as charging oils for the catalytic processes which operate best on these distillates. In 1945 the daily charge to catalytic cracking plants in the United States was one million barrels, practically all gas oil. This has reduced the domestic heating oil consumption appreciably. Residual stocks from cracking processes, both thermal and catalytic, have about the same boiling ranges as the gas-oil distillates produced in straight-run crude distillation. These stocks, however, contain high percentages of cyclic hydrocarbons, both naphthenic and aromatic, and hence are refractory and carbon-forming when further cracked, so that they do not constitute the best charging stocks for catalytic cracking plants. However, they are suitable for use as furnace oils and may supplement straight-run distillates used for this purpose.

**Residual Fuel Oil.**

The residual high-boiling liquid products from the primary distillation of crude oil or from

cracking plants have thus far found their principal use as industrial fuel for steam raising and other heating.<sup>188,184</sup> While some of the lighter more paraffinic crude oils, such as those from Pennsylvania, yield residues which can be worked into waxes, petrolatum, and lubricants, the bulk of the residues from crude-oil distillation are black and asphaltic in character and suitable only for fuel for cracking in specially designed plants wherein they produce, in addition to gas and gasoline, extremely heavy asphaltic residuum or coke. Heavy fuel oils are usually burned by atomising them into a combustion chamber with air or steam. In order to prevent clogging of pump valves and burner tips, they should be low in suspended carbonaceous material. A low content of mineral sediment prevents erosion of burners and fittings. The pour point should be reasonably low to prevent solidification on storage. The A.S.T.M. gives specifications for different types of fuel oils (Table LXX).

#### LUBRICATING OILS.

These are made from the portions of petroleum boiling at higher temperatures than gas oils, so that to avoid decomposition the primary lubricating oil distillates are produced under sub-atmospheric pressure or its equivalent using steam. The principal requisites of lubricating oils are: (1) Suitable viscosity; (2) ability to retain viscosity at elevated temperatures; (3) stability under service conditions; (4) freedom from gummy, adhesive, or abrasive materials; (5) sufficiently low cold-test; (6) proper flash point.

Petroleum yields varying amounts of distillates from which commercial lubricants can be prepared by sulphuric acid treatment, solvent extraction, de-waxing, filtration through or contact with absorbents such as fuller's earth or granular chars, and the use of additives such as pour-point depressants. Some petroleum of low specific gravity contain high proportions of gasolines and have only small value as a source of lubricants, while others are of use principally for lubricant manufacture. Some data are given in Table VII on the yields of lubricating oils from miscellaneous petroleum.

More details on processes involved in lubricating-oil manufacture, their chemical composition, the use of additives to improve their properties, their methods of testing, the mechanisms of fluid and boundary lubrication, and the nature of fractional forces are found under the heading of LUBRICATION AND LUBRICANTS (v. Vol. VII, 385d).

#### PARAFFIN WAX (v. this Vol., p. 403d).

Many petroleum contain dissolved "solid paraffin hydrocarbons, the amount recoverable from crude oils being as high as 3% by weight. These hydrocarbons comprise both n- and iso-paraffins containing from about 15 to 35 carbon atoms per molecule. They occur in highest percentages in petroleum of the paraffinic type, in diminishing percentages through mixed base crudes, and in low quantities in the heavier asphaltic oils. The presence of these wax

materials restricts the flow of many crude oils in the ground and accounts for the deposits of the so-called rod wax on pump rods. Waxy materials frequently settle to the bottom of crude oil storage tanks, particularly if the temperature of storage is lower than that of the oil underground.<sup>185</sup>

Solid paraffin hydrocarbons are distributed in the gas-oil and lubricating-oil fractions of crude petroleum. Some of these fractions, usually high-boiling gas oils or lighter lubricants being called paraffin or wax distillates. Where wax is a desired product the primary crude distillation is conducted so that a distillate containing a relatively high percentage of wax is recovered for processing. Some paraffin distillates may contain 25% or higher of paraffins solid at ordinary temperatures.

The manufacture of refined white paraffin wax from petroleum involves a number of steps. If the distillate is from a paraffinic crude and substantially free from asphaltic or tarry constituents, the process of wax manufacture is relatively simple. If asphaltic materials are present, they are removed by sulphuric acid or absorbents such as fuller's earth in a preliminary <del>d necessary to re-nm and shghtly crack the

tion easier. However, later developments have cast some doubt on the necessity of this step. The wax distillate is refrigerated to bring its temperature to about -12 to -9° c. (10 to 15°F.) and filter pressed, a wax cake being collected between canvas-covered perforated steel plates. This so-called "slack wax" may still contain as much as 30-40% oil. Pressed oil from the filter may be further processed at successively reduced temperatures to obtain more complete separation of the original wax. The "pressed distillate" from which the paraffin has been removed is used as a base for the manufacture of low cold-test lubricants.

To remove the oil from the "slack wax," it is subjected to a "sweating" operation as follows: The "sweater" is a large shallow pan 15 to 20 ft. square and about a foot deep. It contains a supported horizontal screen a few inches above the bottom of the pan and a flat horizontal pipe coil above the screen. The pan contains water to a depth sufficient to just submerge the screen. The "slack wax" is melted and pumped onto the water layer and solidified to a cake by pumping a refrigerating liquid through the pipe coil. The lower layer of water is then drawn off and the wax cake settles onto the screen. By slowly raising the temperature of the room containing this "sweater," the wax cake is slowly and uniformly heated so that the oil drips or "sweats" from the cake of wax crystals. The recovered oil from this step is known as Foot's oil. It contains some paraffin and may be reprocessed with original paraffin distillate.

After the removal of the oil by "sweating," the wax is remelted and subjected to finishing treatments which may involve percolation through bone black or fuller's earth, contact clay treatment, or treatment with sulphuric acid. Most marketed paraffin waxes contain less than

TABLE LXX.—DETAILED REQUIREMENTS FOR FUEL OILS. (a)

Grade.	Flash point,		Pour point, °F.	Water and sediment, %.	Carbon residue, %.	Ash, %.	Distillation temperatures, °P-					Viscosity, seconds.				
	Mfn.	Max.					Max.	Max.	Max.	Max.	10% point.		90% point.		End point.	
			Max.	Max.	Min. *	Max.					Min.	Max.	Mfn.	Max.	Min.	
No. 1. A distillate oil for use in burners requiring a volatile fuel.	100 or legal.	150	IS>	0.05	0.02	—	420	—	—	600	—	—	—	—	—	—
No. 2. A distillate oil for use in burners requiring a moderately volatile fuel.	HO or legal.	190	15(6)	0.05	0.05	—	440	620	—	—	600	—	—	—	—	—
No. 3. A distillate oil for use in burners requiring a low-viscosity fuel.	110 or legal.	200	15(6)	da	0.1-5	—	—	—	620 (d)	—	—	70	—	—	—	—
No. 4. An oil for use in burners requiring low-viscosity fuel.	150	—	(«)	1.0	—	0.1	—	—	—	—	—	500	70(«)	—	—	—
No. 5. An oil for use in burners equipped with preheaters permitting a medium-viscosity fuel.	150	—	—	1.0	—	0.15	—	—	—	—	—	—	—	100	25	—
No. 6. An oil for use in burners equipped with preheaters permitting a high-viscosity fuel.	150	—	—	2.00	—	—	—	—	—	—	—	—	—	300	100 (y)	—

(a) Recognising the necessity for low-sulphur fuel oils used in connection with heat-treatment, non-ferrous metal, glass and ceramic furnaces, and other special uses, a sulphur requirement may be applied, in accordance with the following table:

Grade of fuel oil.	Sulphur, max., %.
No. 1.	0.5
No. 2.	0.5
No. 3.	0.75
No. 4.	1.25
No. 5.	no limit.
No. 6.	no limit.

Other sulphur limits may be specified only by mutual agreement between the buyer and seller.

(b) Lower or higher pour-points may be specified whenever required by conditions of storage or use. However, these specifications shall not require a pour point lower than 0°F. under any conditions.

(c) Pour point may be specified whenever required by conditions of storage or usage. However, these specifications shall not require a pour point lower than 15°K. under any conditions.

(d) This requirement shall be waived when the carbon residue is more than 0.07% and less than 0.16%.

(e) This requirement shall be waived when the carbon residue is more than 1.0%.

(f) A deduction in quantity shall be made for all water and sediment in excess of 1.0%.

(g) This requirement shall be waived when the carbon residue is 4% or more.

1% of oil and the average is not more than 0-3%. The melting-point of a wax depends upon its oil content and the boiling range of the wax distillate from which it was made. Grades of wax are marketed having melting-points at 3°c. (5°f.) intervals from 38° to 66°c. (100° to 150°f.). Those melting below 49°c. (120°f.) are soft waxes and those above 54°c. (130°f.) are generally classified as hard waxes. Intermediate grades include melting-points between 49° and 54°c. (120° and 130°f.). The melting-point of paraffin wax is readily determined by stirring the molten wax with a thermometer bulb, and noting as the wax cools the temperature at which a lag in the rate of cooling occurs.

An important modification in paraffin wax manufacture involves the use of liquid propane as a solvent.<sup>186</sup> The paraffin-containing distillate is dissolved in liquid propane under pressure at atmospheric or slightly elevated temperature. Asphaltic materials are insoluble and are precipitated and removed by settling so that a solution of purified paraffin wax in propane is obtained. Cooling and separation of wax is brought about by evaporating part of the propane, or the solution may be cooled by heat exchange with a refrigerating liquid. The wax precipitated at the reduced temperature may be removed by settling, but better by pressure filtration. The oil dissolved in the propane after separation of the wax is recovered by distilling off the propane. "Sweating" of the filtered wax is usually unnecessary to produce a product of low oil content.

Other solvents which are used in wax manufacture are acetone-benzol mixtures and chloroethylene compounds. Using the latter type, the wax is less dense than the oil-solvent mixture, which can be removed by centrifuging.

Petrolatums are mixtures of solid paraffin hydrocarbons and viscous oils.<sup>187</sup> They were first manufactured from paraffin-base Pennsylvania oils, but are now obtained from other crude oils by partial centrifugal dewaxing of viscous distillates produced by vacuum distillation. The solid hydrocarbons in petrolatums are micro-crystalline and constitute from 10 to 15% of its weight. Petrolatums are sometimes made by melting paraffin waxes with highly refined lubricating oils or medicinal oils.

By the solvent extraction of the oil in petrolatums, micro-crystalline waxes are recovered which have higher melting-points than those obtained by other processes. One marketed grade melts at 77-79°c. (170-175°f.), and another at 88-91°c. (190-195°f.). These waxes are flexible at extremely low temperatures and resistant to moisture so that they are used extensively in packaging, in airplane wing deicing, and the impregnation of footwear.

Refined paraffin waxes for coating and sealing purposes are colourless, odourless, and tasteless. They find extensive use in candle manufacture, in waterproofing paper, leather, and textiles, in food preservation, in electrical cables, condensers, and switches, as insulating materials, in polishes and in physiotherapy.

Natural or mineral waxes include ozokerite, and montan wax, the latter being extractable from lignite by means of solvents. Constituents

of ozokerite have melting-points varying from 60 to 93°c. (140 to 200°f.), while montan waxes melt from 77 to 93°c. (170 to 200°f.). Refined ozokerite is sold under the name of "Ceresin". It is presumed that mineral waxes were filtered from petroleum's migrating through porous strata.

#### ASPHALT.

The word asphalt has its origin in ancient Babylonia. Originally it meant "firm, stable, or secure," and was evidently descriptive of the use, of the material as a cement. To-day the term asphalt is applied to minerals or petroleum residues having a pitchy, tarry, or adhesive character which are solid or semi-solid, brown or black, low-volatile hydrocarbon mixtures fusible on heating. This definition includes many natural and manufactured materials which are used as binders in road or building aggregates, or as waterproofing and sealing materials in roof coverings and paints. It excludes materials made from wood tar, coal tar, and shale tar, although uses of these latter tars and pitches may overlap the uses of petroleum asphalts.<sup>188,189</sup>

Natural asphalts contain varying amounts of mineral matter, from traces to as high as 50%. Crystallisable paraffins are usually absent. Oxygen rarely exceeds 5%, and nitrogen is seldom present in amounts over 2%.

The origin of natural asphalts is presumed to be the same as of liquid petroleum, the asphalts being residues left after the evaporation of the lighter portions of liquid oils. Natural asphalts occur in widely separated localities. There were many seepages and pits in ancient Persia and the areas around the Black, Caspian, and Red Seas. The working of these surface deposits furnished asphalt for building and road construction, and also the waterproofing of boats. There are definite indications that asphalt was used by the Sumerians as far back as 3000 B.o. The Egyptians used asphalt to mummify their kings and important personages. Streets in ancient Babylon were made by setting stones in asphalt, and the floors of many temples are still intact.

The most famous source of natural asphalt is the Pitch Lake of Trinidad, which was first described by Sir Walter Raleigh after a visit to the lake in 1595. The Asphalt Lake covers an area of about 100 acres in the crater of an extinct mud volcano. Borings have shown an asphalt of uniform composition to a depth of 285 ft. The asphalt is emulsified with water and fine clay, the inorganic matter constituting 35 to 40% by weight of the mass. A similar but smaller lake occurs in north-eastern Venezuela and is known as Bermudez Pitch Lake. It covers an area of about 900 acres and the asphalt has an average depth of about 4 ft.

There are several natural asphalt deposits in the United States. Gilsonite occurs in Utah and Colorado in veins which extend for a total distance of about 60 miles. A variety known as Grahamite occurs in West Virginia, this material resembling several similar deposits in Cuba, South America, and Trinidad. The tar sands occurring in the Canadian province of Alberta contain a soft asphaltic material impregnating a loose sandstone. The total

asphaltic content of these stands has been estimated\* to be between 100 and 250 billion barrels, constituting an enormous reserve of hydrocarbons. Owing to the thick and sticky character of the tar which is separated from the sand, the recovery of the hydrocarbon material involves mining and displacement by means of hot water.

Artificial or manufactured asphalts are obtained as residues in the distillation of asphalt-containing petroleum. The crude oils are first fractionated in the usual combination of heated pipe coil and fractionating column to distil off gasoline, kerosene, and gas oils. The residue from this primary step is subjected to further distillation in similar equipment, which is maintained under reduced pressure to prevent decomposition or cracking of the heavier portions of the crude. Under these conditions lubricating oils are distilled and an asphaltic residue is obtained, the consistency of which will increase with the amount of material volatilised. The consistency of asphalt varies over wide ranges. Some are so hard and brittle that they are readily ground to powder. The lighter asphalts exhibit fluid flow at ordinary temperatures, even though they may appear solid. Between these grades there are asphalts of varying degrees of hardness, fluidity, and plasticity, so that a large number of grades are available which can be adapted to almost any service.

Asphalts are readily hardened and their melting-points are raised by controlled oxidation or by the action of sulphur. In the first case, oxidation, dehydrogenation, and condensation reactions occur with elimination of water and low boiling aliphatic and naphthenic acids. When sulphur is used, a certain amount reacts and some is converted to hydrogen sulphide and various sulpho-acids. In the manufacture of oxidised, high melting-point asphalts for roofing, it is common practice to blow air through an asphaltic residuum at a rate which maintains the temperature of the mass of asphalt without other heating, the rate of oxidation for this purpose usually being sufficient at temperatures above 204°c. (400°F.). Steam may be employed along with the air to control the oxidation rate and to assist in vaporising the products of the oxidation reaction.

Many tests are applied to determine the physical and chemical characteristics of asphalts. One of the most important measures of consistency is the penetration test, in which a weighted needle of standard dimensions is allowed to sink into a test sample at a standard temperature for a fixed time. Hard and brittle asphalts may show a zero penetration by this method. The types used in road aggregates vary from 10 to around 100 mm. penetration, depending upon the service and climatic conditions. Asphalts of over 100 penetration merge into oily materials which are used for light road surfacing and dust laying.

The softening- or melting-point of an asphalt is not as sharp as those characterising pure substances, and is determined by several alternative methods. Melting-points of soft asphalts vary from 38 to 66°c. (100 to 150°F.). Some of the harder natural and manufactured varieties may

have melting-points as high as 260°c. (500°F.), as in the case of oxidised or sulphurised materials.

Another important test which gives indications as to the binding properties of an asphalt is the ductility test, in which a small briquette is pulled apart and the extension is noted at which a break occurs. Ductility tests are usually made at 25°c. (77°F.). For details A.S.T.M. test method D-1 13-35 may be consulted. Ductility, measured in centimetres of extension before breakage, varies from zero in hard, brittle, high melting-point asphalts to over 100 cm. for many softer varieties, 100 cm. being the usual limit of test machines.

Other tests employed in rating the consistency of asphalts include tests in which the rate of flow of a small portion of asphalt in an inclined metal channel is noted. Attempts have been made to measure directly the adhesive properties of asphalts. In such tests, asphalt is placed in the annular space between a horizontal rod and a co-axial sleeve, and the relative adhesiveness determined by noting the force necessary to twist the sleeve. Such tests are difficult to check and correlate with actual service and have not found general acceptance.

The majority of natural asphalts have specific gravities varying between 0.95 and 1.15, although a few Grahamites have values as high as 1.20. Residual asphalts in the distillation of petroleum have specific gravities in about the same range as the natural asphalts, depending upon their consistency, which in turn depends upon the extent of the distillation practised on the crude petroleum from which they are made; whether vacuum or steam was employed or whether air-blowing was practised to raise the melting-point.

Evaporation tests are conducted to determine the percentages of material volatile at 163-204°c. (325-400°F.), and the reduction in penetration which occurs after such evaporative tests.

The surface appearance of an asphalt may give indication as to its character. A material free from large amounts of mineral matter or paraffin will have a smooth black reflecting surface, while large amounts of mineral matter will dull its lustre; paraffin tends to give the surface a mottled and waxy appearance. Mineral matter is not always objectionable, particularly in natural asphalts, but the presence of large amounts of paraffin tends to lower adhesive properties.

Asphalts are arbitrarily differentiated by their solubility in different liquids. Mineral matter is insoluble in carbon disulphide. The so-called "carbenes" or heavy coke-like particles are insoluble in carbon tetrachloride. Components known as asphaltenes are soluble in carbon tetrachloride but insoluble in light paraffin naphtha having a specific gravity of 0.650 (A.P.I. gravity about 86). "Carbenes" are generally low in natural asphalts but may amount to several per cent, in manufactured asphalts, which have been overheated and cracked, or overburned in the process of air oxidation. Asphaltenes are oxygen-containing compounds, while the portions soluble in paraffin naphtha commonly

referred to as petrolenes or malthenes and essentially hydrocarbons.

In 1944, 6,996,100 short tons of petroleum asphalt were produced in the United States.<sup>190</sup>

#### SPECIAL PRODUCTS INCLUDING CHEMICAL DERIVATIVES.

Petroleum is used as a base for the manufacture of many special hydrocarbon products and hydrocarbon derivatives.<sup>191</sup> All of the gaseous hydrocarbons can be isolated from natural or cracked gases, or synthesised from other components. Natural gas and petroleum provide sources of hydrogen, hydrogen sulphide, methane, ethane, ethylene, acetylene, propane, propylene, n-butane, isobutane, 1-butylene, 2-butylene, isobutylene and butadiene from simple fractionation or primary conversions. *cyclo-Propane*, *cyclobutane*, and *cyclobutylene* are producible from the primary gaseous products by secondary reactions. Separation of individual normally liquid hydrocarbons is growing, and eventually many of these will be utilisable directly or as a base for chemical derivatives.

Petroleum supplies *n*- and iso-pentane, and *n*- and iso-hexanes. neopentane, neohexane, 2,3-dimethylbutane, and isoprene are produced by syntheses involving dehydrogenation, isomerisation, alkylation, and dealkylation reactions. Isomeric octanes including 2:2:3-, 2:2:4-, and 2:3:4-trimethylpentanes, and triptane, 2:2:3-trimethylbutane, are synthesised from petroleum cracked gases. Benzene, toluene, xylenes, and more highly methylated benzenes are obtained by dehydrogenation of *cyclohexane* and *methylcyclohexane*, or by methylating benzene. Ethylbenzene is produced by catalytically alkylating benzene with ethylene or ethyl alcohol, and styrene by dehydrogenating the ethylbenzene. Alkylation of benzene with propylene yields isopropylbenzene (cumene), and the dehydrogenation of this compound yields *α*-methylstyrene. Naphthalene is a direct product of cracking petroleum and also of dehydrogenating butylbenzenes.

The lower boiling fractions of petroleum furnish liquid gases such as propane and propane-butane mixtures for domestic and industrial heating, fuels for internal combustion engines, and a number of hydrocarbon solvents. These include 86-88° A.P.I. gravity paraffin naphthas for asphalt solubility tests, petroleum ethers, solvents for extracting drugs and chemicals, paint, varnish, and lacquer vehicles, and solvents for rubber cements, textile proofing and finishing, dry cleaning, and rotogravure inks.

Owing to the relative ease of separation of individual normally-gaseous hydrocarbons, these low molecular weight members of the various hydrocarbon groups furnish, base materials for the manufacture of chemical derivatives.<sup>198</sup> The reagents for primary reactions with hydrocarbons are the halogens (particularly chlorine), oxygen, water, sulphuric acid, nitric acid, the halogen acids, and hypochlorous acid. Once a primary derivative is obtained, secondary reactions lead to practically all classes of organic compounds, so that the chemistry of hydrocarbons is in fact an introduction to the whole field of organic chemistry.

The action of chlorine on methane produces methyl chloride, methylene dichloride, chloroform, and carbon tetrachloride by successive substitution of hydrogen atoms. These chlorine compounds are used as cleaning fluids and as solvents for various adhesives and rubber cements. Chloroform and carbon tetrachloride are used as anesthetics, and special solvents. Carbon tetrachloride constitutes a large percentage of non-inflammable cleaning fluids, a fire extinguishing fluid ("*Pyrene*"), and a solvent for testing asphalts and tars. Methyl chloride is a reagent for adding methyl groups to both aliphatic and cyclic hydrocarbons. Methane also furnishes the difluoro-dichloro derivative, "*Freon*," (CF<sub>2</sub>Cl<sub>2</sub>), which is widely used as a liquid for refrigeration.

The oxidation of methane yields formaldehyde and methyl alcohol and readily separable primary products. From the alcohol, dimethyl ether and various esters are made. Formaldehyde polymerises to paraformaldehyde and its cyclic isomer, trioxane. Formaldehyde is used in large quantities as a disinfectant and in phenol-formaldehyde resins ("*Bakelite*").

By reaction with steam in contact with selected catalysts, methane yields mixtures of carbon monoxide and hydrogen which furnish the mixtures charged to the Fischer-Tropsch process for synthesising alcohols, aldehydes, acids, or hydrocarbons. By reaction of 1 mol. of methane and 2 mol. of water, 1 mol. of carbon dioxide and 4 mol. of hydrogen are produced, the hydrogen being readily separated for use in hydrogenation reactions.

Methane reacts with the vapours of nitric acid to form nitromethane, the first of a series of nitro-paraffins which are excellent solvents for nitrocellulose, cellulose acetate, and the vinyl resins. Similarly, ethane is nitrated in vapour phase. Nitropropane, which is made by similar vapour-phase reactions, is used as an anti-gelling agent in synthetic rubber cements, and the low molecular weight nitro-paraffins are all utilisable in inks and protective coatings. The nitro-paraffins are readily reducible to the corresponding amines.

Ethylene is the starting material for a multitude of chemical derivatives. Its direct polymerisation furnishes the plastic known as "*Polythene*." The hydrolysis of ethyl sulphuric acid or ethyl chloride gives ethyl alcohol. From ethyl alcohol, diethyl ether, acetaldehyde, acetone, acetic acid, and ethyl esters are produced. Ethylene and hypochlorous acid react giving ethylene chlorohydrin as a primary product, which yields ethylene glycol on further hydrolysis. This compound is the basis of a large number of secondary derivatives, including polyethylene glycols resulting from dehydration and condensation reactions, glycol esters, glycol ethers, ether-alcohols, ether-esters, di-chloro-ethyl ether ("*Chlorex*"), and various ethanolamines. By the low-temperature catalysed oxidation of ethylene, ethylene oxide is produced, which can also be hydrolysed to ethylene glycol. In addition, it reacts with hydrocyanic acid to form acrylonitrile, the material used in the manufacture of "*Buna-N*" rubber. Similarly, ethylene oxide reacts with hydrogen chloride to



form vinyl chloride and subsequently the vinyl resins. The direct addition of chlorine to ethylene yields ethylene dichloride, which reacts with sodium tetrasulphide to form "Thiokol" rubbers. Ethylene and hydrogen chloride form ethyl chloride which reacts with sodium-lead alloy to form the widely used anti-knock agent, tetraethyl lead.

Natural gas or products therefrom under high temperature conditions readily yield acetylene. Two commercial acetylene units are being installed at the present time (1945), one of which will produce at the rate of 75 tons a day or 27,000 tons a year. Other units are also under way. The charging stock may be either propane, butane, natural gasoline, or fractions from petroleum. It is believed that acetylene can be produced at a lower cost by processing natural gas than by the electro-chemical method of producing calcium carbide. The natural gas industry has enormous volumes of propane and other hydrocarbons available to supply the whole needs of the United Nations for acetylene and its derivatives. Acetylene may be converted to butadiene by a number of processes involving different sequences of steps. In one process it is converted to vinylacetylene which can be made to yield butadiene on hydrogenation. In another process, acetylene is converted to acetaldehyde by hydration, the aldehyde is then caused to undergo the aldol condensation; butanediol is produced by hydrogenation, and butadiene by catalysed dehydration. Acetylene yields acrylonitrile by reaction with hydrogen chloride, and vinyl chloride with hydrogen chloride, and is also a base substance used in the manufacture of nylons. Chlorination produces such important solvents as tetrachloroethane, trichloroethylene, and pentachloroethane. Trichloroethylene is used for degreasing metal parts in airplane and automobile manufacture).

Propane and propylene produced therefrom by catalytic or thermal dehydrogenation are bases for another series of chemical compounds. Propane is directly nitratable in the vapour phase. By absorbing propylene in 87% sulphuric acid and subsequently hydrolysing the monoisopropyl sulphate, isopropyl alcohol is produced. The alcohol itself finds many industrial uses as a solvent, denaturant, and intermediate. By the catalytic dehydrogenation of isopropyl alcohol, acetone is readily obtained, and from this compound an aldol condensation gives diacetone alcohol and, on subsequent dehydration, mesityl oxide. By the usual dehydration with sulphuric acid, isopropyl alcohol yields isopropyl ether, which has been found to have exceptionally high anti-knock rating in motor fuel blends in contrast to the knocking tendencies of diethyl ether. Like ethylene, propylene adds a molecule of chlorine to form propylene dichloride, and reacts with hydrogen chloride to form isopropyl chloride. The high temperature interaction of chlorine with propylene can be made to produce allyl chloride, from which hypochlorous acid produces the dichlorohydrin, and further hydrolysis produces glycerol, from which edible esters and nitroglycerin can be manufactured.

The four-carbon-atom paraffin hydrocarbons, including *n*-butane and isobutane, also yield

large numbers of commercial products, *n*-Butane yields normal butylenes and then butadiene on successive dehydrogenation, using such catalysts as chromium sesquioxide on alumina. By hydrolysis with sulphuric acid, *n*-butylenes yield *sec*-butyl alcohol, and isobutylene the *tert*-butyl compound. Oxidation of *sec*-butyl alcohol produces methyl ethyl ketone used in the manufacture of lacquer thinners, and as a solvent for vinyl resins and the dewaxing of lubricating oils. Alternatively, butene-2 adds hypochlorous acid to form 2-chlorobutan-3-ol, which yields methyl ethyl ketone by dehydrochlorination.

By catalytically dehydrogenating isopentane and isopentenes or their mixtures, isoprene is produced. Butadiene and isoprene are key hydrocarbons in the manufacture of synthetic rubbers. The synthetic rubber produced in greatest volume in 1944 was "Buna"-8 or GB-8 by the co-polymerisation of butadiene and styrene; this being the rubber used in the manufacture of pneumatic tyres. The United States production of synthetic rubber was 750,000 tons in 1944, and at the end of the year the industry was geared to an annual production of 900,000 long tons.<sup>193</sup>

Butyl rubber is made by the polymerisation of isobutylene and small percentages of butadiene or isoprene. "Vistanex" is a high molecular-weight polymer of isobutylene. "Buna"-N rubber is produced from butadiene and acrylonitrile. "Thiokol" rubbers are made from ethylene dichloride and sodium tetrasulphide. "Neoprene" rubbers are polymers of chloroprene. The many varieties of synthetic rubbers include products adaptable to uses to which the natural rubber is unsuited, particularly in regard to resistance to air oxidation, contact with oils, and resistance to chemicals. Table LXXI lists the starting materials and the formulas and names of synthetic rubbers produced from them.<sup>194</sup>

Table LXXII, which lists a number of products being made from petroleum hydrocarbons, indicates the extent of the chemical industry which is based on it.<sup>196</sup> While the volume production of chemical derivatives is less than 1% (1945), it shows every indication of rapid growth. The aromatic hydrocarbons in coal tar have been starting materials for half a million chemical compounds, and it is not unlikely that petroleum will eventually yield twice as many.

### Medicinal Oils.

By exhaustive acid treatment and finishing of what are essentially the lubricant fractions of petroleum, highly refined products known as white oils are produced.<sup>196</sup> These oils are made by treating lubricating fractions with fuming sulphuric acid in amounts as great as 50% by volume of the oil, and treatment may be continued until from 25 to 50% of the more reactive and unstable components are removed. Preliminary treatments to remove the more reactive components of the oils are practised, and the treatment with fuming acid is followed by complete neutralisation with sodium hydroxide or lime, and percolation through fuller's earth.

White oils consist predominantly of cycloparaffin hydrocarbons with minor amounts of

TABLE LXXI.—STBUOTUBAL RELATIONS AMONG MONOMERS AND POLYMERS.

Monomers.	Basic recurring groups of polymers.	Nature of product.
Isoprene $\text{CH}_2=\text{C}(\text{CH}_3)-\text{CH}=\text{CH}_2$	$\left[ \text{CH}_2-\text{C}(\text{CH}_3)=\text{CH}-\text{CH}_2 \right]_n$	Natural rubber or caoutchouc.
Butadiene $\text{CH}_2=\text{CH}-\text{CH}=\text{CH}_2$	$\left[ \text{CH}_2-\text{CH}=\text{CH}-\text{CH}_2 \right]_n$	"Buna"-58 and 115 (German); no U.S. production.
Butadiene+styrene $\text{CH}_2=\text{CH}-\text{CH}=\text{CH}_2 + \text{C}_6\text{H}_5-\text{CH}=\text{CH}_2$	$\left[ \text{CH}_2-\text{C}(\text{C}_6\text{H}_5)=\text{CH}-\text{CH}_2-\text{CH}(\text{C}_6\text{H}_5)-\text{CH}_2 \right]_n$	"Buna"-S; "Buna"-SS.
Butadiene+acrylonitrile $\text{CH}_2=\text{CH}-\text{CH}=\text{CH}_2 + \text{CH}_2=\text{CH}-\text{CN}$	$\left[ \text{CH}_2-\text{CH}(\text{CN})-\text{CH}(\text{CH}_2)-\text{CH}_2 \right]_n$	"Buna"-N, "Perbunan," "Hy-car"-OR,* "Chemigum."*
Butadiene+isobutylene $\text{CH}_2=\text{CH}-\text{CH}=\text{CH}_2 + \text{CH}_2=\text{C}(\text{CH}_3)-\text{CH}_2$	$\left[ \text{CH}_2-\text{CH}(\text{CH}_3)-\text{CH}(\text{CH}_2)-\text{CH}_2 \right]_n$	"Butyl" rubber.*
1,2-Chloroprene $\text{CH}_2=\text{C}(\text{Cl})-\text{CH}=\text{CH}_2$	$\left[ \text{CH}_2-\text{C}(\text{Cl})=\text{CH}-\text{CH}_2 \right]_n$	"Neoprene."
Vinyl chloride $\text{CH}_2=\text{CH}-\text{Cl}$	$\left[ \text{CH}_2-\text{CH}(\text{Cl}) \right]_n$	"Koroseal," "Flamenoir," "Vinylite"-Q.
Isobutylene $\text{CH}_2=\text{C}(\text{CH}_3)-\text{CH}_2$	$\left[ \text{CH}_2-\text{C}(\text{CH}_3)-\text{CH}_2 \right]_n$	"Yistanex."*
Dichloroethyl ether+sodium tetrathiolate $\text{ClCH}_2-\text{CH}_2-\text{O}-\text{CH}_2-\text{CH}_2\text{Cl} + \text{Na}_2\text{S}_4$	$\left[ \text{CH}_2-\text{CH}_2-\text{O}-\text{CH}_2-\text{CH}_2-\text{S}-\text{S}-\text{S}-\text{S} \right]_n$	"Thiokol"-B.
P. V. A.+butyraldehyde $\left[ \text{CH}_2-\text{CH}(\text{H})-\text{CH}_2-\text{CH}(\text{C}_6\text{H}_5) \right]_n + \text{H}_1\text{CHO}$	$\left[ \text{CH}_2-\text{CH}(\text{H})-\text{CH}_2-\text{CH}(\text{C}_6\text{H}_5) \right]_n$	"Butacite," "Butar," "Vinylite"-X.

\* identity not disclosed by the manufacturer but reported to be of the type indicated.

paraffins. They are odourless and free from objectionable taste, stable to hot 95% sulphuric acid, and do not acquire colour on exposure to air and sunlight. A well-prepared white oil should show little colour change in six weeks' exposure to sunlight at ordinary temperature. Unger air exposure at 100°C. (212°F.), a good oil will not show rancidity in 16 hours. They vary in viscosity from about 50 to 350 Saybolt seconds at 38°C. (100°F.), and even those containing more paraffin hydrocarbons seldom have pour-points above 0°C. (32°F.).

Such oils are used largely for medicinal or pharmaceutical purposes. They have purgative action and are used in salves, skin creams, oint-

ments, nasal drops, and throat sprays. They are also used by bakers and candymakers in lubricating and greasing equipment, and in packing fruit and preserving eggs.

#### Mahogany and Green Acids.

Another class of special petroleum products are the prepared oil-soluble sulphonic acids which are known as mahogany acids or green acids.<sup>197</sup> These are made by treating white oils with sulphuric acid. The mahogany acids are extracted from the treated oils with alcohol, neutralised with alkali, and used most commonly as alkali metal soaps. They may be further purified by solution in organic solvents, settling

TABLE LXXII—PRODUCTS FROM PETROLEUM.

Fractionation

Methane, Ethane, Propane, Butanes, Pentanes, Hexanes, Heptanes, Octanes.

Dehydrogenation.

Hydrogen, Acetylene, Ethene, Propene, Butadiene, Pentenes, Isoprene, Pentadienes, Hexenes, Heptenes, Octenes, Benzene, Toluene, Styrene.

Halogenation.

Methyl chloride.  
Methyl bromide.  
Methyl iodide.  
Methylene dichloride.  
Chloroform.  
Carbon tetrachloride.  
Dichlorodifluoromethane  
(*CFreon*).

Ethyl chloride.  
Ethyl bromide.  
Ethyl iodide.  
Trichloroethane.  
Pentachloroethane.  
Hexachloroethane.  
Ethylene chloride.  
Tetrachloroethylene.  
Ethylene chlorohydrin.

Dichloropropane.  
Trichloropropane.  
Propylene dichloride.  
isopropyl chloride.  
isopropyl iodide.  
isopropyl bromide.  
AUI chloride.

Chlorobutene.  
Butylene dichloride.  
isobutylene dichloride.  
Butylene chlorohydrin.  
Methyl chloride.  
Butyl halides.  
Pentyl halides.

Derivatives of Halogenated Products.

Tetraethyl-lead.  
Ethyl mercaptan.  
Sulphonal.  
Ethylcellulose.  
Diethylbenzene.  
Diethylaniline.

Vinyl chloride.  
Ethylene glycol.  
Dichloroethyl ether.  
Dioxan.  
Diglycol.  
Diethylene glycol.  
Triethylene glycol.  
Succinic acid.  
Ethylene oxide.  
Monoethanolamine.  
Diethanolamine.  
Triethanolamine.  
"Thiokol" (rubber).

d/cisopropane (anesthetic).  
Propylene oxide.  
Propylene glycol.  
isopropyl alcohol.  
AUI alcohol.  
Diallyl ether.  
Methyl vinyl carbinol.  
Sulphur dioxide resins.  
isopropyl ether.  
isopropyl acetate.  
isopropylbenzene  
(cumene).

Butadiene.  
Butylene glycol.  
tert.-butyl alcohol.  
Methylglycerol.  
Methyl methacrylate  
resins ("jtocite").  
Butylamines.  
Amylamines.  
Hexylamines.  
Aminobutanol.

i Nitration Products.

Nitromethane.

Nitroethane.

1-Nitropropane.  
2-Nitropropane.

1-Nitrobutane.  
2-Nitrobutane.

Derivatives of Nitration Products.

Tri(hydroxymethyl)  
nitromethane.  
Tri(hydroxymethyl)-  
aminomethane.  
1-Chloro-1-nitroethane.  
1,1-Dichloro-1-nitro-  
ethane.  
Monoethylamine.  
Diethylamine.  
Triethylamine.  
Diethylaminoethanol.

Phenyldiethanolamine.  
Propylamines (rubber accelerators).  
1-Chloro-1-nitropropane.  
2-Chloro-2-nitropropane.  
Nitrohydroxypropanes (synthesis of  
high explosives).  
Aminohydroxypropanes (emulsifying  
agents).  
Chloronitropropanes (insecticides).  
Hydroxylamine salts (floatation  
reagents).  
Chloronitroalcohols.  
Acrylonitrile.

2-Nitro-1-  
-butanol.  
2-Nitro-2-methyl-1-propanol.  
2-Nitro-2-methyl-1,3-propanediol.  
2-Amino-2-methyl-1-propanol.  
2-Amino-2-ethyl-1,3-propanediol.

Alcohols, Ethers, Ketones, Adds, Esters, Aldehydes, Chlorohydrins.

Methyl alcohol.  
Formic acid.  
Methyl esters.  
Formaldehyde.  
Methyl ether.  
Methyl vinyl carbinol.

Ethyl alcohol.  
Acetic acid.  
Acetone.  
Acetaldehyde.  
Diethyl ether.  
Ethyl esters.  
Metallic ethoxides.  
Di-Phenylethanol.  
Diethyl carbinol.

n-Propyl alcohol.  
isopropyl alcohol.  
isopropyl ether.  
Propionic acids.  
Propyl esters.  
Propyl ethers.  
Propionaldehyde.  
Propyl ketones.  
Olycerol.  
Glyceryl chlorohydrin.  
Glyceryl dichlorohydrin.

n-Butyl alcohol.  
tert.-butyl alcohol.  
sec.-butyl alcohol.  
Butyric acids.  
Butyl esters.  
Butyl ethers.  
Butaldehydes.  
Butyl ketones  
isobutylene chlorohydrin.  
Methyl ethyl ketone.  
Chloroallyl alcohol.  
Pentamethylene glycols.

Miscellaneous Oxygen and Other Compounds.

sec.-Amyl formate.  
Amyl acetate.  
Amyl propionate.  
Amyl butyrate.  
Amyl ether.  
Amylphenol.  
tert.-Amyl acetate.  
Diacetonealcohol.  
isobutylcarbinol.  
n-Amyl alcohol.

sec.-Amyl alcohol.  
tert.-Amyl alcohol.  
Crotonaldehyde.  
Malic acid.  
sec.-Hexyl alcohol.  
sec.-Hexyl acetates.  
sec.-Hexyl butyrates.  
sec.-Hexyl propionates.  
Amyl mercaptans.  
Diethyl sulphide.  
Amylnaphthalenes.

Diamylnaphthalene.  
Polyamylnaphthalene.  
Monoamylbenzene.  
Diamylbenzene.  
Triamylbenzene.  
Tetra-amylbenzene.  
2:4-Diamylphenol.  
Dimethylacetone.

Paraformaldehyde.  
Hexamethylenediamines.  
Heptyl alcohols.  
Octyl alcohols.

or filtering, and bleaching with hydrogen peroxide. Oil is removed from the soap by extraction of its alcoholic solution with light petroleum. The recovered dry material is resinous, orange-yellow, and hygroscopic, with a melting-point below 60°c. (140°F.).

Both the acid and the soaps are completely dispersible in water. The principal use of mahogany soaps is in textile oils, metal-cutting oil emulsions, and catalysts for the hydrolysis of fats.

The so-called green acids are separated from the sludge produced in treating white oils by diluting with water to a 50% sulphuric acid, in which they have a minimum solubility. These acids are also used as such or as alkali metal or alkaline earth metal soaps. They are used as emulsifiers, wetting agents, pickling inhibitors, metal-flotation oils, and in dust laying compounds.

### Detergents.

A number of detergents are made from petroleum, some being analogous to soaps made by saponification of mineral and vegetable fats, and others by new types of reactions.<sup>196</sup>

Soap substitutes were made in Germany by the action of sodium hydroxide on acids made by oxidising petroleum fractions. In Russia, soaps are made by alkaline treatment of naphthenic acids present in petroleum oils. In other processes, mineral and vegetable fats are saponified with amines from the reduction of nitroparaffins. In still other processes, alkali metal hydroxides are treated with benzene sulphonic acids in which the benzene ring contains alkyl substituent groups having from 10 to 12 carbon atoms.

### Insulating Oils.

Petroleum provides a source of neutral insulating oils for electrical transformers and switches.<sup>198</sup> Highly purified dry oils of the consistency of light lubricants have dielectric strength and breakdown voltages as high as 70 kilovolts in standard test apparatus. Transformer oils act not only as insulating media, but as means of conducting heat away and preventing overheating of transformers. They are necessarily neutral, non-corrosive, and free from sulphur. The flash point is usually high enough to prevent fires from accidental electrical sparks, and the oils are resistant to oxidation in contact with air at temperatures encountered in the transformers. Similar types of oils are used in impregnating paper used in electric cables.<sup>199</sup> A common impregnating material is a blend of mineral oil and rosin, while others contain oil and petrolatum.

### Insecticides and Fungicides (v. this Vol., p.301).<sup>2</sup>

Petroleum fractions are used as vehicles in insecticides and fungicides.<sup>200</sup> Kerosenes were first used and, later, emulsions of oils of higher boiling range in the lubricating class, since it has been found that less damage to plants occurs with the higher viscosity oils. The oils are frequently in combination with nicotine, pyrethrum, den-is, or lead arsenate. A 2% solution of D.D.T. (aa-di-(i>-chlorophenyl)-j3j3j3-trichloro-

ethane) in kerosene has proved effective against flies, mosquitoes, and lice, and in the control of plant pests. Kelosene emulsions are also used to kill soil insects.

Experience indicates that paraffins and naphthenes have little or no adverse effects on plants, and that aromatic and olefinic constituents are actively toxic to pests but damage the plant. The properties of oil vehicles which are best for tree and plant spraying are different in summer and winter. The recommended specification for an oil vehicle for summer use is shown in Table LXXIII, whilst a suggested specification for a winter insecticidal oil vehicle is given in Table LXXIV.

TABLE LXXIII.

Sp.gr. at 15.5°C. (60°F.)	0.86-0.92.
Boiling above 300°C (572°F.)	Not less than 90%.
Boiling below 330°C. (625°F.)	Not less than 10%.
Boiling between 340° and 365°c. (644° and 689°F.)	9
Viscosity, Redwood No. 1 at 21°C. (70°F.)	Not less than 50%.
Viscosity, Saybolt Universal at 38°C. (100°F.)	75-150 seconds.
	60-115 seconds.

TABLE LXXIV.

Sp.gr. at 15.5°C. (60°F.)	0.86-0.92.
boiling above 315°C. (599°F.)	At least 90%.
Boiling above 350°C. (662°F.)	At least 50%.
Boiling above 380°C (716°F.)	At least 20%.
Viscosity, Redwood No. 1 at 21°C. (70°F.)	Between 125-500 seconds

The use of oil sprays to kill the larvae of mosquitoes in stagnant pools is well established, and oil sprays are used to prevent insect attacks in stored goods. They are also used to spray livestock.

Many unsaturated hydrocarbon gases are used effectively in stimulating plant growth and the ripening of fruit.<sup>201</sup> Ethylene gas is used as a ripener for oranges and as an anaesthetic. Both ethylene and propylene are used to stimulate the growth of potatoes by treating the seedlings. Butylene gas accelerates the growth of apple, apricot, pear, cherry, plum, peach, and walnut trees. Acetylene has been successfully employed to accelerate the ripening of and growth of pineapples.

### TESTING AND ANALYSIS OF PETROLEUM AND ITS PRODUCTS.

The complex chemical character of petroleum and its refined products and their widely varying physical properties require many diverse types of chemical analyses and physical measurements for their complete determination. The literature on these topics is so extensive that even an approach to a comprehensive recitation is beyond the scope of the present general account. Analytical and test methods have been worked out and standardised by committees of experts in the American Society for Testing Materials (U.S.A.), and in the Institute of Petroleum Technologists (Great Britain). These methods are described in detail in "Standards on Petroleum Products and Lubricants," prepared by A.S.T.M. Committee D-2, issued annually, and "Standard Methods for Testing Petroleum and Its Products," published by the Institute of Petroleum. In addition to these publications

the C. J. Tagliabue Manufacturing Company, makers of petroleum testing instruments, publish a "Manual for Inspectors of Petroleum," which describes the more common physical and chemical tests and analyses, and is useful as a guide for petroleum inspectors. The United States Federal Stock Catalog also contains details of test methods and specifications for petroleum products. Other manuals are available which are published by companies engaged in the petroleum industry. *E.g.*, Universal Oil Products Company publishes "Laboratory Test Methods for Petroleum and Its Products," which contains the more common and many special analytical and test methods, in addition to those in the publications of governmental and technical societies.

To estimate the commercial value of crude oils and their refined products and to check quality during refining and other operations, reliance is placed principally on rapid determination of physical properties, such as specific gravity or corresponding values on empirical scales, volatility by determination of boiling-point range and vapour pressure, colour *b'J* transmitted and reflected light, and combustion properties indicated by flash and fire points, spontaneous ignition temperatures, anti-knock ratings, etc. Relative consistency tests for viscosity, plasticity, and resistance to flow are applied to heavy liquid and semi-solid products, such as lubricating oils, greases, residual fuel oils, and asphalts.

The specific gravities of liquid petroleum and their fractions are most frequently determined by hydrometers at room temperature and corrected to 60°F. (15.5°C). Specific gravities are referred to water at the same temperature. Gravity values for solid and semi-solid products such as waxes, petrolatums, and asphalts are determined in pycnometers. The coefficients of expansion of petroleum products vary with their composition and boiling range, and with temperature, so that gravity correction factors should be used with caution.

Laboratory evaluations of combustion properties of fuels and illuminants are in current practice. The suitability of motor gasoline, aviation fuel, tractor fuel, and diesel fuel is determined directly in small engines rather than estimated from their physical and chemical properties, which do not always enable correct judgment of their relative fuel values. Determinations of flash and fire points of kerosenes are made in the interest of safety, and they are burned in standard test lamps to obtain information as to their actual illuminating value, wick smoking tendencies, and their effects on wicks and chimneys.

In comparing the consistencies of heavier products, determinations are made of relative viscosity, melting, softening, and freezing temperatures, ductility and resistance to flow, in the majority of instruments employed for determining viscosity, the oil flows through a standard capillary tube or orifice under a gravity head, and arbitrary unit values are recorded which are converted to absolute or kinematic viscosity. Special methods are employed for estimating the relative oiliness of lubricants on

the one hand and the relative binding properties or adhesiveness of tars and asphalts on the other.

Colours are determined by comparing with standard glasses and solutions. Refractive indices and Raman, X-ray, infra-red, and ultra-violet spectra furnish valuable data. The mass spectrometer is employed as an adjunct in the analysis of hydrocarbon gas mixtures.

Inorganic matter, including mineral particles and water, are determined by distillation of the water, and centrifuging out water and solid mineral particles after dilution of oils with organic solvents. Paraffin wax is also determined by dilution with appropriate solvents and cooling, filtering, and weighing the separated wax crystals. The relative solubility of residuums and asphalts in organic solvents such as carbon disulphide, carbon tetrachloride, and light paraffin naphthas give indications of the source and quality of such products.

Miscellaneous tests include determination of mercaptan and total sulphur, existent and potential gum in gasoline, corrosive properties (usually with copper), total halogens, acidity and alkalinity, oxidation and light stabilities, saponification values, bromine numbers, ultimate analyses for carbon, hydrogen, oxygen, nitrogen, and sulphur, and percentages of the main hydrocarbon groups, paraffins, olefins, naphthenes, and aromatics. The last-named analysis is difficult on account of the extremely large number and variable chemical constitution of the hydrocarbon mixtures constituting petroleum fractions, and reports of such determinations should be taken with some reserve.

#### Literature Cited.

- 1 G. Egloff, "Earth Oil," Williams and Wilkins Co., 1933, p. 4.
- 2 H. Abraham, "Asphalts and Allied Substances," Van Nostrand & Co., 1920, p. 4.
- 3 B. J. Forbes, "Bitumen and petroleum in Antiquity," E. J. Brill (Leiden), 1936, p. 11.
- 4 G. Egloff, "Earth Oil," Williams and Wilkins Co., 1933, p. 12.
- 5 *Idem, ibid.*, p. 13.
- 6 EdwaTd Thorpe, "Dictionary of Applied Chemistry," 3rd ed., Longmans, Green & Co., 1928, Vol. V, p. 113.
- 7 Anon., Oil and Gas Journal, 1935, 34, No. 31, p. 12.
- 8 Anon., Oil Weekly, 1944, 116, No. 2, p. 66.
- 9 Anon., World Petroleum, 1944, 18, No. 12, p. 60.
- 10 V. C. Filling, "Science of Petroleum," Oxford Univ. Press, 1938, Vol. I, pp. 32 et seq.
- 11 W. E. Pratt, Bull. Amer. Assn. of Petroleum Geologists, 1944, 28, 150G.
- 12 Petroleum Industry Research Foundation, Inc., "World Oil, Fact and Policy," 1944, p. 8.
- 13 W. E. Pratt, "Oil in the Earth," Univ. of Kansas Press, 1942, p. 40.
- 14 V. C. Hirsch, Automotive and Aviation Industries, 1944, 91, No. 1, p. 18.
- 15 is Amer. Petroleum Inst., Report of Comm. on Petroleum Reserves, Feb. 19, 1944, Chem. Eng. News, 1944, 22, 640.
- 16 H. Fosset, "Petrol, Its Development, Past, Present and Future," J. Inst. of Automobile Engineers, London, 1944, 12, No. 8, p. 89.
- 17 c. Engler and H. von Hofer, "Chemie und Physik des Erdöls," S. Herzel (Leipzig), 1913, Vol. I, p. 239.
- 18 is *Idem, ibid.*, p. 271.
- 19 » *Idem, ibid.*, p. 308.
- 20 *Idem, ibid.*, p. 347.
- 21 *Idem, ibid.*, p. 359.
- 22 A. F. Forziati, C. B. Wellingham, B. J. Mair, and F. D. Rossini, Amer. Petroleum Inst. Meeting, Chicago, U.S.A., Nov. 10, 1943; Refiner, 1943, 22, No. 11, p. 379.
- 23 B. Emmet Reid, "Science of Petroleum," Oxford Univ. Press, 1938, Vol. II, p. 1033.
- 24 J. R. Bailey, *ibid.* p. 1047.

- 25 A. C. Bratton and J. R. Bailey, *J. Amer. Chem. Soc.* 1937, 69, 175.
- 26 J. Von Braum, "Science of Petroleum," Oxford Univ. Press, 1938, Vol. II, p. 1007.
- 27 E. Field, F. H. Dempster, and G. E. Tilson, *Ind. Eng. Chem.* 1940, 32, 489.
- 28 H. Abraham, "Asphalts and Allied Substances," Van Nostrand & Co., 1929, p. 40.
- 29 W. H. Thomas, "Science of Petroleum," Oxford Univ. Press, 1938, Vol. II, p. 1053.
- 30 G. Egloff, "Earth Oil," Williams and Wilkins Co., 1933, p. 125.
- 31 R. F. Bacon and W. A. Hamor, "American Petroleum Industry," McGraw-Hill Co., 1916, Vol. II, p. 717.
- 32 c. 8. Robinson and E. R. Gilliland, "Elements of Fractional Distillation," McGraw-Hill Co., 1939, p. 202.
- 33 *Idem, ibid.*, p. 204.
- 34 *Idem, ibid.*, p. 205.
- as L. Nelson, "Petroleum Refinery Engineering," McGraw-Hill Co., 1936, p. 451.
- 36 A. E. Dunstan, A. W. Nash, B. T. Brooks, and H. Tizard, "Science of Petroleum," Oxford Univ. Press, 1938, Vol. II, pp. 840 *et seq.*
- 37 U.S. Dept. of Interior, Bureau of Mines, Mineral Industry Surveys, Monthly Petroleum Statement No. P. 258, Released March 5, 1945.
- 38 B. T. Brooks, "Science of Petroleum," Oxford Univ. Press, 1938, Vol. III, pp. 2078 *et seq.*
- 39 A. N. Sachanen, "Conversion of Petroleum," Reinhold Pub. Corp., 1940, pp. 38, 57, 76, 92.
- 40 V. N. Ipatieff, "Science of Petroleum," Oxford Univ. Press, 1938, Vol. III, p. 2079.
- 41 Universal Oil Products Co., unpublished data.
- 42 *Ibid.*
- 43 *Ibid.*
- 44 A. N. Sachanen, "Conversion of Petroleum," Reinhold Pub. Corp., 1940, p. 168.
- 45 *Idem, ibid.* p. 125.
- 46 G. Egloff, E. F. Nelson, and G. B. Zimmerman, *Oil and Gas J.* 1935, 34, No. 32, p. 90.
- 47 J. R. Bates, F. W. Rose, Jr., S. S. Kurtz, Jr., and I. W. Mills, *Ind. Eng. Chem.* 1942, 34, 147.
- 48 G. F. Fitzgerald, *Chem. and Met. Eng.* 1939, 46, No. 4, p. 196.
- 49 C. R. Wagner, *Oil and Gas J.* 1943, 41, No. 46, p. 63.
- 50 E. V. Murphree, *I.W.D. Eng. Chem.* 1943, 36, 623.
- 51 C. L. Thomas, N. E. Anderson, and J. McAfee, *Nat. Petroleum News*, 1943, 36, No. 48, p. R-570.
- 52 c. L. Thomas, U.S.P. 2328754, 2328755, and 2328756; issued Sept. 7, 1943.
- « Universal Oil Products Co., unpublished data.
- 34 E. V. Murphree, H. G. M. Fischer, E. J. Gohr, W. J. Sweeney, and C. L. Brown, *Petroleum Engineer*, 1944 Reference Annual, 16, No. 10, p. 230.
- « A. N. Sachanen, "Conversion of Petroleum," Reinhold Pub. Corp., 1940, p. 38.
- « *Idem, ibid.*, p. 57.
- « *Idem, ibid.*, p. 76.
- 38 *Idem, ibid.*, p. 92.
- » G. Egloff, J. C. Morrell, and A. F. Nelson, *Oil and Gas J.* 1937, 36, No. 26, p. 176.
- 60 M. B. Cooke, J. R. Swanson, and C. R. Wagner, *ibid.* 1935, 34, No. 26, p. 57.
- «i S. H. McAllister, *Refiner*, 1937, 16, No. 11, p. 493.
- «2 G. Egloff, *Nat. Petroleum News*, 1935, 27, No. 47, p. 25.
- «3 G. Egloff, *Oil and Gas J.* 1936, No. 22, p. 58; *Nat. Petroleum News*, 1936, 28, No. 42, p. 25.
- 64 V. N. Ipatieff, and G. Egloff, *Oil and Gas J.* 1935, 83, No. 52, p. 31; *Nat. Petroleum News*, 1935, 27, No. 20, p. 24.
- 65 Universal Oil Products Co., unpublished data.
- 66 Universal Oil Products Co., unpublished drawing.
- 67 G. Egloff, *Nat. Petroleum News*, 1935, 27, No. 47, p. 25.
- 68 G. Egloff *Oil and Gas J.* 1936, 34, No. 44, p. 140.
- 69 G. Egloff, *Ind. Eng. Chem.* 1936, 28, 1461.
- 70 Z. M. Watson, U.S.P. 2120723; issued June 14, 1938.
- U. B. A. Kazanskii, and M. I. Rozengart, *Nat. Petroleum News*, 1944, 36, No. 36, p. R-643.
- 72 A. V. Grosse, V. N. Ipatieff, G. Egloff, and J. C. Morrell, *Proc. Amer. Petroleum Inst.*, Nov. 9-17, 1939, 20, Sec. III, Refining.
- 73\* A. W. Nash, and D. A. Howes, "The Principles of Motor Fuel Preparation and Application," Chapman and Hall, Ltd., 1938, p. 398.
- 74 c. C. Watson, F. Newton, G. W. McCausland, E. H. McGrew, and L. S. Kassel, *Trans. Amer. Inst. of Chem. Engrs.* 1944, 40, No. 3, p. 309.
- 75 Universal Oil Products Co., unpublished data.
- 76 R. o. Lassiat/and F. D. Parker, *Nat. Petroleum News*, 1944, 36, No. 49, p. R-842.
- 77 J. M. Mavity, and E. E. Zetterholm, *Trans. Amer. Inst. of Chem. Engrs.* 1944, 40, pp. 473-485.
- 78 R.R. Dreisbach, U.S.P. 2110829; issued March 8, 1938.
- 79 S. Berkman, J. C. Morrell, and G. Egloff "Catalysis," Reinhold Pub. Corp., 1940, p. 1054.
- so A. E. Buell and P. M. Waddill, *Refiner*, 1944, 23, No. 10, p. 83.
- si H. G. M. Fisher and A. E. Welty, Jr., *Chem. and Met. Eng.* 1944, 61, No. 8, p. 92.
- 82 A. N. Sachanen, "Conversion of Petroleum," Reinhold Pub. Corp., 1940, p. 80.
- 83 J. P. O'Donnell, *Oil and Gas J.* 1944, 42, No. 42, p. 73.
- 84 A. N. Sachanen, "Conversion of Petroleum," Reinhold Pub. Corp., 1940, p. 81.
- 85 W. J. Mattox, *Trans. Amer. Inst. Chem. Engrs.* 1945, 41, 403.
- 86 A. N. Sachanen, "Conversion of Petroleum," Reinhold Pub. Corp., 1940, p. 27.
- 87 F. E. Key and H. T. Hepp, *Ind. Eng. Chem.* 1936, 29, 29.
- 88 V. G. Oberfell and E. Frey, *Oil and Gas J.* 1939, 38, No. 28, p. 60.
- 89 K. G. Mackenzie, *Refiner*, 1939, 18, No. 11, p. 494.
- 90 E. V. Murphree, *Ind. Eng. Chem.* 1943, 35, 623.
- 91 C. G. Gerhold, J. O. Iverson, H. J. Nebeck, and R. J. Newman, *Trans. Amer. Inst. Chem. Engrs.* 1943, 39, No. 6, p. 793.
- 92 A. V. Grosse and V. N. Ipatieff, *J. Org. Chem.* 1943, 8, 38.
- 93 G. Egloff, G. Hulla, and V. I. Komarewsky, "Isomerization of Pure Hydrocarbons," Reinhold Pub. Corp., 1942, p. 31.
- 94 S. Berkman, J. C. Morrell, and G. Egloff, "Catalysis," Reinhold Pub. Corp., 1940, p. 1021.
- 95 J. A. Chenicek, C. G. Dryer, R. E. Sutherland, and J. O. Iverson, *Nat. Petroleum News*, 1944, 36, No. 40, p. R-678.
- 96 G. Egloff, G. Hulla, and V. I. Komarewsky, "Isomerization of Pure Hydrocarbons," Reinhold Pub. Corp., 1942, \* 31.
- 97 *Idem, ibid.*, pp. 35 *et seq.*
- 98 *Idem, ibid.*, pp. 29 *et seq.*
- 99 *Idem, ibid.*, p. 00.
- 100 c. Ellis, "Hydrogenation of Organic Compounds," Van Nostrand Co., 1930, pp. 564-616.
- 101 R. P. Russell, "Science of Petroleum," Oxford Univ. Press, 1938, Vol. III, p. 2133.
- 102 S. Berkman, J. C. Monjell, and G. Egloff, "Catalysis," Reinhold Pub. Co., 1940, pp. 1013, 1040.
- 103 B. B. Corson and G. S. Monroe, U.S.P. 2296346-7; issued Oct. 13, 1942.
- 104 A. N. Sachanen, "Conversion of Petroleum," Reinhold Pub. Corp., 1940, pp. 89 *et seq.*
- 105 R. T. Haslam and R. P. Russell, *Ind. Eng. Chem.* 1930, 22, 1030.
- 106 R. T. Haslam, R. P. Russell, and W. C. Asbury, *Refiner*, 1933, 12, No. 9, p. 370.
- 107 A. P. Russell, E. J. Gohr, and A. J. Voorhies, *J. Inst. Petroleum Techn.* 1935, 21, 347.
- 108 E. V. Murphree, E. J. Gohr, and C. L. Brown, *Ind. Eng. Chem.* 1939, 31, 1083.
- 109 V. A. Kalichevsky and S. A. Stagner, "Chemical Refining of Petroleum," Chemical Catalog Co. 1933; A.C.S. Monograph No. 63.
- 110 J. C. Morrell and G. Egloff, *Nat. Pet. News*, 1936, 38, No. 12, p. 33; *Oil and Gas J.* 1936, 34, Nos. 44, 45, 46; J. C. Morrell and G. Egloff, "Sulphuric Acid Treatment of Cracked Distillates," World Petroleum Congress, London, 1933.
- 112 J. C. Morrell, *J. Ind. Eng. Chem.* 1926, 18, 733.
- 113 J. C. Morrell and G. Egloff, *Refiner*, 1923, 11, No. 9, p. 60-A.
- 114 H. S. Bell, "American Petroleum Refining," Van Nostrand Co., 1930, p. 296.
- 115 M. J. Fowle and H. W. Field, *World Petroleum*, 1942, 13, No. 2, p. 44.
- 116 H. N. La Croix, *Oil and Gas J.* 1944, 42, No. 40, p. 50.
- 117 J. P. O'Donnell, *ibid.* 1944, 43, No. 8, p. 45.
- 118 B. L. MacKufflick, and H. A. Alves, *ibid.* 1944, 42, No. 49, p. 126.
- 119 V. A. Kalichevsky and S. A. Stagner, "Chemical Refining of Petroleum," Chemical Catalog Co., 1933; A.C.S. Monograph No. 63, p. 186.
- 120 Roy Cross, "Handbook of Petroleum, Asphalt, and Natural Gas," Kansas City Testing Lab. Bull. 25, 1928 Revision, p. 548.

- <sup>121</sup> A. R. Bowen, "Science of Petroleum," Oxford Univ. Press, 1938, Vol. II, p. 1500.
- <sup>122</sup> Amer. Petroleum Inst. "Petroleum Facts and Figures, 7th Ed., 1941, p. 91.
- <sup>123</sup> H. L. Ickes, "Petroleum News, 1944, 37, No. 1, p. 16.
- <sup>124</sup> L. F. Terry, Gas Age, 1944, 9P, No. 11, p. 30.
- <sup>125</sup> B. C. Adams, Jr., and F. H. Dotterweich, Industry and Power, 1944, 47, No. 5, p. 56.
- <sup>126</sup> Anon., Pipe Line News, 1945, 17, No. 7, p. 18.
- <sup>127</sup> J. F. Pew, "Natural Gas and its Products During the War," Petroleum Administration for War, Nov. 28, 1945.
- <sup>128</sup> U.S. Dept. of Interior, Bureau of Mines, Mineral Industry Surveys, No. MMS-1174, May 25, 1944.
- <sup>129</sup> F. A. Paneth, "Science of Petroleum," Oxford Univ. Press, 1938, Vol. II, p. 1511.
- <sup>130</sup> G. Egloff and M. Alexander, Refiner, 1944, 3, No. 6, pp. 123-128.
- <sup>131</sup> Amer. Petroleum Inst., "Petroleum Facts and Figures," 7th ed., 1941, p. 113.
- <sup>132</sup> U.S. Dept. of Interior, Bureau of Mines, Mineral Industry Surveys, Monthly Petroleum Statement No. P. 258, Released March 5, 1945, p. 10.
- <sup>133</sup> B. L. Häsche, Chem. arji Met. Eng. 1942, 49, No. 7, p. 78.
- <sup>134</sup> G. Egloff and E. F. Nelson, Oil and Gas J. 1936, 35, Nos. 6, 7, and 8.
- <sup>133</sup> Universal Oil Products Co., unpublished data.
- <sup>136</sup> A. N. Sachanen, "Conversion of Petroleum," Reinhold Pub. Corp., 1940, p. 371.
- <sup>137</sup> Universal Oil Products Co., unpublished data, as A. N. Sachanen, "Conversion of Petroleum," Reinhold Pub. Corp., 1940, p. 372.
- <sup>139</sup> G. Egloff and J. C. Morrell, Ind. Eng. Chem. 1934, 26, 94Cb
- <sup>140</sup> U.S. Dept. of Interior, Bureau of Mines, Reports of Investigations, National Motor Gasoline Surveys.
- <sup>141</sup> E. Graham, Prooc. A.S.T.M., June 24, 1942; 17th Edgar Marburg lecture, Fig. 6.
- <sup>142</sup> *Idem*, *ibid.*, Fig. 5.
- <sup>143</sup> J. G. "Detwiler" and M. P. Doss, "Science of Petroleum," Oxford Univ. Press, 1938, Vol. IV, p. 2401.
- <sup>144</sup> B. T. Brooks, *ibid.*, Vol. II, p. 987.
- <sup>143</sup> J. G. Morrell and G. Egloff, *ibid.*, p. 98.
- <sup>146</sup> *idem*, *ibid.*, p. 1002.
- <sup>147</sup> G. Egloff, Oil and Gas J. 1936, 35, No. 22, p. 58; Nat. Petroleum News, 1936, 38, No. 42, p. 25.
- <sup>148</sup> V. N. Ipatieff and G. Egloff, Oil and Gas J. 1935, 33, No. 52, p. 31; Nat. Petroleum News, 1935, 27, No. 20, p. 24.
- <sup>149</sup> F. D. Rossini, Record of Chemical Progress, 1942, 3, No. 4, p. 53.
- <sup>150</sup> G. Egloff and P. M. Van Arsdell, Inst. Petroleum, 1941, 27, No. 210, p. 121.
- <sup>151</sup> G. Egloff, J. Chem. Educ. 1941, 18, 682.
- <sup>152</sup> M. Van Winkle, "Aviation Gasoline Manufacture," McGraw-Hill Co., 1944, p. 203.
- <sup>153</sup> Roy Cross, "Handbook of Petroleum, Asphalt, and Natural Gas," Kansas City Teuting Lab. Bull. 25, 1928 Revision, p. 356.
- <sup>154</sup> Amer. Petroleum Inst., "Petroleum Facts and Figures," 7th ed., 1941, p. 106.
- <sup>155</sup> U.S. Dept. of Interior, Bureau of Mines, Mineral Industry Surveys, Monthly Petroleum Statement No. P. 258, Released March 5, 1945, p. 10.
- <sup>156</sup> M. Van Winkle, "Aviation Gasoline Manufacture," McGraw-Hill Co., 1944.
- <sup>157</sup> R. C. Alden and B. Parker, Oil and Gas J. 1937, 36, No. 1, p. 72.
- <sup>158</sup> C. C. Pryor, Petroleum Engineer, 1943, 14, No. 6, p. 61.
- <sup>159</sup> Petroleum Industry War Committee, Nat. Petroleum News, 1944, 36, No. 15, p. 22.
- <sup>160</sup> Anon., Fortune, 1943, 27, No. 5, p. 152.
- <sup>161</sup> C. F. Kettering, Ind. Eng. Chem. 1944, 36.
- <sup>162</sup> M. Van Winkle, Refiner, 1943, 23, No. 9, p. 273.
- <sup>163</sup> A. T. Colwell, R. E. Cummings, and D. E. Anderson, Soc. Auto. Engrs. Detroit Meeting, Jan. 8, 1944.
- <sup>164</sup> British Information Services, Report on the Flying Bomb, D-549, Sept. 1944.
- <sup>165</sup> Science News Letter, 1944, 46, No. 23, p. 357.
- <sup>166</sup> G. D. Boerlage and J. J. Broeze, "Science of Petroleum," Oxford Univ. Press, 1938, Vol. IV, pp. 2486, 248b
- <sup>167</sup> J. S. Bogen and G. C. Wilson, Nat. Petroleum News, Tech. Sect. 1944, 86, No. 18, p. R-284.
- <sup>168</sup> Amer. Petroleum Inst., "Petroleum Facts and Figures," 7th ed., 1941, p. 54.
- <sup>169</sup> J. Kewley and C. L. Gilbert, "Science of Petroleum," Oxford Univ. Press, 1938, Vol. IV, p. 2488.
- <sup>170</sup> A. T. Colwell, "Fuel Requirements for Farm Tractors," Soc. of Auto. Engrs. Milwaukee Meeting, Sept. 13, 1944.
- <sup>171</sup> G. Egloff and P. M. Van Arsdell, Chem. and Eng. News, 1942, 20, 649.
- <sup>172</sup> G. Egloff and M. Alexander, Refiner, 1944, 23, No. 6, pp. 123-128.
- <sup>173</sup> A. L. Foster, Oil and Gas J., 1944, 42, No. 35, p. 39.
- <sup>174</sup> G. Egloff and P. M. Van Arsdell, "Motor Vehicles Propelled by Producer Gas," Amer. Chem. Soc. Pittsburgh Meeting, Sept. 5, 1943; Petroleum Division.
- <sup>175</sup> J. Kewley and C. L. Gilbert, "Science of Petroleum," Oxford Univ. Press, 1938, Vol. IV, pp. 2470 *et seq.*
- <sup>176</sup> A. W. Trusty, Petroleum Engineer, 1943, 14, No. 8, p. 118.
- <sup>177</sup> U.S. Dept. of Interior, Bureau of Mines, Mineral Industry Surveys, Monthly Petroleum Statement No. P. 258, Released March 5, 1945, p. 3.
- <sup>178</sup> F. O. Rossini and B. J. Mair, "Progress Report on the Hydrocarbons in the Kerosene Fraction of Petroleum," Project 6, Amer. Petroleum Inst. Meeting, San Francisco, Nov. 5, 1941.
- <sup>179</sup> R. H. Griffith, "Science of Petroleum," Oxford Univ. Press, 1938, Vol. IV, p. 2523.
- <sup>180</sup> J. J. Morgan, "Manufactured Gas," J. J. Morgan, 1925, Vol. I, p. 265.
- <sup>181</sup> J. A. Van Dyk, Het Gas, 1933, 63; Amer. Chem. Abs. 1934, 28, 885.
- <sup>182</sup> E. T. Knight, Fuel Oil News, 15 Sept. 1944, p. 15.
- <sup>183</sup> J. S. S. Brame, "Science of Petroleum," Oxford Univ. Press, 1938, Vol. IV, p. 2548.
- <sup>184</sup> A.S.T.M. Standards on Petroleum Products and Lubricants, 1937, p. 354.
- <sup>183</sup> W. J. Wilson and S. T. Minchin, "Science of Petroleum," Oxford Univ. Press, 1938, Vol. IV, p. 2679.
- <sup>186</sup> W. H. Bahlke, R. N. Giles, and C. E. Adams, "Dewaxing Oils in Propane Solution with Self-refrigeration," Amer. Petroleum Inst., Tulsa Meeting, May 18, 1933.
- <sup>187</sup> B. T. Brooks, "Science of Petroleum," Oxford Univ. Press, 1938, Vol. II, p. 994.
- <sup>188</sup> H. Abraham, "Asphalts and Allied Substances," Van Nostrand & Co., 1929, p. 4.
- <sup>189</sup> W. W. Goulston, "Science of Petroleum," Oxford Univ. Press, 1938, Vol. IV, pp. 2690 *et seq.*
- <sup>190</sup> U.S. Dept. of Interior, Bureau of Mines, Mineral Industry Surveys, Monthly Petroleum Statement No. P. 258, Released March 5, 1945, p. 4.
- <sup>191</sup> S. F. Birch, "Science of Petroleum," Oxford Univ. Press, 1938, Vol. IV, pp. 2830 *et seq.*
- <sup>192</sup> R. L. Wakeman and B. H. Well, Nat. Petroleum News, 1943, 35, No. 22, p. R-284.
- <sup>193</sup> B. Dewey, American Magazine, 1944, 138, No. 6, p. 25.
- <sup>194</sup> H. I. Kramer, Ind. Eng. Chem. 1942, 34, 243.
- <sup>193</sup> Seminole, Oklahoma, Chamber of Commerce, "Products from Petroleum," p. 12.
- <sup>196</sup> F. M. Archibald, "Science of Petroleum," Oxford Univ. Press, 1938, Vol. IV, p. 2838.
- <sup>197</sup> *Idem*, *ibid.*, p. 2840.
- <sup>198</sup> A. R. Stark, *ibid.*, Vol. II, p. 1443.
- <sup>199</sup> C. Chilvers, *ibid.*, p. 1447.
- <sup>200</sup> C. Potter, *ibid.*, Vol. IV, p. 2843.
- <sup>201</sup> G. Egloff, Science, 1940, 96, 2501-2, pp. 502 and 507.

G. E.

**PETROLEUM WAXES (INCLUDING PARAFFIN WAX).** There are no generally accepted definitions applying to the hydrocarbon waxes derived from petroleum and related mineral oils. The definitions given below, which are based on those proposed by Subcommittee No. 8 of the Standardisation Committee of the Institute of Petroleum, should be regarded as tentative.<sup>1</sup>

"Petroleum Waxes," a term covering the wax-like materials derived from petroleum and related mineral oils (e.g., shale oil), are comprised essentially of normal and branched-chain paraffins and solid hydrocarbons of other saturated series.

Petroleum waxes generally contain oil as an impurity, although, if the oil content is high, the mixture is designated by another term such as



"Wax Distillate," "Slope Wax," "Paraffin Scale," "Petrolatum," "Petroleum Jelly," etc. (*v. infra*). The molecular weights of petroleum waxes vary from about 225 to 1,000 and their setting points (*v. infra*) from about 15° to 105°C. Their consistency may be soft, semi-plastic, or hard, and the relative size of the crystals may vary widely. Their colour varies from almost black (very dark brown) to white.

"Petroleum Wax" is therefore a term covering all wax-like materials from petroleum and related mineral oils. It may be considered as a general definition covering three sub-groups of hydrocarbon waxes.

#### *Paraffin Wax Group.*

This group is obtained from an oily distillate from certain crude oils and shale oils, etc. which consists essentially of wax in association with lubricating oil base and the mixture is usually termed "Wax Distillate." The wax content of such a distillate varies according to the origin of, and the placement of the cut in, the crude oil. "Wax Distillates" may vary in wax content from under 1% to over 40%. (For methods of wax recovery, *v. infra*.)

The essential difference between waxes of this and the other two groups described below is that the paraffin wax group is comprised of waxes that have been distilled from a crude oil. When fully refined, they have a very low oil content (*ca.* 0.3% or under) and a relatively pronounced crystallinity. They are white, and exhibit varying degree of translucency depending on the setting point and source; the best examples are tasteless and odourless. They consist in the main of complex mixtures of the solid normal paraffins (*v. infra*). The molecular weights of paraffin waxes range from about 225 to 450, and their setting points from 30° to 70°C.

Semi-refined paraffin is also produced and is termed "Scale-wax" or "White Scale." Its main difference from paraffin wax is its higher oil content, which varies from 1.5%. It is usually less translucent in appearance, may be slightly more yellow in colour, and have a slightly more pronounced oily odour.

#### *Petrolatum Waxes and Petroleum Ceresins (Microcrystalline and Amorphous Waxes).*

The two remaining groups are frequently referred to by the general term "microcrystalline (or amorphous) waxes." They are obtained from the distillation residues from some crude oils and therefore have a relatively high molecular weight (over 450).

They differ markedly in properties from paraffin wax, one of the most important differences being their very much finer crystallinity. Strictly speaking, they cannot be regarded as amorphous, as they all appear to exhibit some degree of crystallinity, but they are not microcrystalline, if by that term is implied any definite crystalline form. The complexity of the mixture appears to prevent the development of any well-defined crystal masses. Such waxes exhibit a very wide range of properties; *e.g.*, from soft and highly plastic to hard. It appears

as if the softer waxes are mainly comprised of solid saturated hydrocarbons other than *n*-paraffins, and the harder ones mainly of *n*-paraffins. For this reason the definitions suggested<sup>1</sup> recommend that waxes obtained from distillation residues from crude oils be subdivided into two groups: the first to be known as "Petrolatum Waxes" which refers to the softer waxes containing\* mainly hydrocarbon waxes other than *n*-paraffins, and the second, the harder, to be known as "Petroleum Ceresin Group" comprised mainly of hydrocarbons of the *n*-paraffin series.

In practice, waxes from distillation residues from crude oils are rarely definitely "Petrolatum Waxes," or "Petroleum Ceresins" but vary towards one limit or the other depending on the crude oil and the method of preparation. This, of course, is only to be expected, since different crude oils vary in the relative quantities of normal and other saturated solid hydrocarbons, and no commercial method of production is yet available which effects a complete separation of such solid hydrocarbons.

(i) *Petrolatum Waxes*.—These are waxes of fine crystalline structure, which vary in consistency from salve-like to plastic. They vary in colour from dark brown to white, the white examples often exhibiting some degree of translucency. The molecular weight is usually over 450, and the setting points, which in many cases are very ill-defined, range from about 35° to 85°C. They contain considerable quantities of saturated hydrocarbons other than *n*-paraffins.

Certain petrolatum waxes produce petroleum jellies in admixture with substantial quantities of a suitable mineral oil.

(ii) *Petroleum Ceresins*.—These are also waxes of fine crystalline structure, which vary in colour from dark brown to white. Unlike the petrolatum waxes, they are hard and brittle, and this constitutes the main difference between these two groups. Petroleum ceresins have molecular weights ranging from about 450 to 1,000 and setting points from 70 to 105°C. Their composition is at present somewhat obscure, but they appear to be comprised in the main of relatively high molecular weight *n*-paraffins, or paraffins with only a moderate degree of chain branching.

#### METHODS OF PRODUCTION OF PETROLEUM WAXES.

The production of petroleum waxes from crude oil is essentially a matter of purification. Relatively large quantities of oil have to be removed from the crude wax stock, and often also quantities of resinous and asphaltic materials. Further, many refined waxes are comprised of intentionally restricted ranges of solid hydrocarbon constituents, because such are better adapted to most applications.

#### A. Paraffin Wax Group.

As already indicated above, paraffin wax in association with lubricating oil base is present in the oily distillate obtained from some crude oils. This distillate is obtained under vacuum and often in the presence of steam. Its boiling

range varies considerably, depending on the crude oil, "but may be roughly taken as from 300-500°c. at ordinary pressure. Wax distillates may contain up to about 40-50% of wax depending on the source of the Crude Oil. For example, crude oils from S.E. Asia may give wax distillate containing 40% of wax, whereas certain European and American (grudejoils may yield wax distillates containing well under 10% of wax.

Only two of the more usual methods of production will be described.

(i) *Pressing and Sweating\**<sup>88</sup>

The pressing and sweating sequence of operations is conducted as follows.

The wax pistillate is first chilled to the required pressing temperature and then pumped to filter presses. T&e wax, in admixture with a certain amount of oil, is retained between the filter blankets, and the oil drains off as filtrate. The presses vary in design, but may be of the 4 ft. diameter plate type, consisting of, say, 500 plates per press. Design of the plates, spacing of the plates, and weave and trea&ment of the cloths, vary considerably. Pressures imposed also vary, the maximum being in the neighbourhood of 500 lb. per sq. in.

If the wax content of the wax distillate is low, one pressing operation at a suitable sub-atmospheric temperature may suffice to remove all the marketable wax, but where the wax distillate contains large quantities of wax, a series of pressing operations is often -desirable. For example, the wax distillate is chilled to the first pressing temperature, and the filtrate oil chilled to the next, and so on, until the requisite wax removal has been effected. In this instance, the operation amounts to a series of crystallisations conducted at descending temperatures with the oil as solvent. In this manner a segregation of wax according to solubility (and therefore setting point) may be realised in the pressing operation.

Since the press cakes are not washed, they contain oil, which varies from about 7 to 40% depending on the crude oil, the wax contenjb of the wax distillate cut» and the temperature at which the wax distillate is pressed. These crude wax cakes are known as "slack wax " or " crude scale."

The slack wax is further purified by a process known as sweating which, essentially, is partial melting. It aims at effecting two separations at the same time:

- (a) The removal of oil to a final wax product containing under 0.3% of oil;
- (b) Segregation of the wax into ranges of setting point.

Many different types of sweater are employed of widely varying design ranging from relatively large buildings housing banks of shallow trays (to hold the slack wax undergoing sweating) to tanks heated by closely spaced vertical tubes. In all cases the principle is the same, namely, the slack wax is charged in the molten condition to the trays or tanks and then cooled and

solidified to the required initial sweating temperature. Any liquid is then allowed to drain from the slack-wax mass. These drainings are termed "sweats " or "foots oil." The temperature of the sweater is then raised (by the circulation of warm air or water, or both) so that sweats flow continuously from the sweating mass. It is usually the custom to keep the sweating rate reasonably constant, and this may vary from 1 to 5% of the charge per hour. This is realised by gradually raising the temperature of the sweater either continuously or in a series of small temperature intervals. As the operation proceeds, the oil content of the "sweats " falls until a residue is left of much lower oil content than the charge. The residue is melted out, and if necessary re-sweated. Intermediate cuts are also re-sweated (recycled) until, finally, two products remain: (a) the residue wax of the desired oil content which requires a finishing treatment, and (6) the combined foots oil which may contain up to 70% of oil.

Sweating schemes may become most complex in an endeavour to recover all marketable wax.<sup>38</sup>

A simple sweating scheme would be:

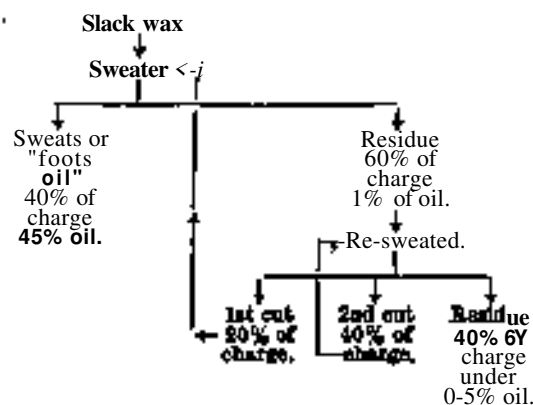

Sweating, as normally practised, is discontinuous and is a slow operation, much time being involved in charging, cooling, and melting out, apart from the actual sweating. A quick sweating, say on a 40-50 ton charge, rarely takes less than 24 hours, but a more usual period is from 30 to 96 hours or more. It is, however, reasonably cheap, and the equipment is simple, no special solvents being required.

The actual mechanism by which sweating accomplishes de-oiling may be conceived somewhat as follows. The waxes of lowest setting point liquefy first within the interstices of the mass of slack wax, thereby diluting the oil which is held on the crystal surfaces. When the interstices are full, oily liquid (sweats) is ejected from the mass. This proceeds as sweating continues, thereby accomplishing a continuous washing operation within the sweating mass, where the solvent is the low setting-point portion of the wax, or,

$$dw/ds = w/L$$

where  $dw/ds$  is the concentration of oil in sweats at any stage of the operation,  $w$  is the weight of oil in the sweating mass, and  $L$  is the weight of liquid.

An example of the de-oiling achieved by sweating is shown in Table I below.

TABLE I.—SWEATING OF SLACK WAX.  
Oil content, 17.5%; setting point, 41.9°. Sweated into 10% fractions by volume.

Fraction.	Setting point, °0.	% oil by weight.
1	33.0	51.2
2	38.1	32.8
3	38.7	28.5
4	40.7	21.1
5	42.5	13.6
6	44.2	6.51
7	46.3	2.78
8	46.0	0.97
9	46.5	0.42
10	47.0	0.15

(ii) *Solvent De-oiling.*

In essence, a solvent method of separating wax from oil consists in the crystallisation of the wax distillate from a suitable solvent, and washing the wax cake as free as possible from oily liquor with further quantities of solvent. The wax cake may be recrystallised with solvent and reprocessed if necessary.

In practice, this requires the employment of a solvent which is as selective as possible between wax and oil, and that can be recovered and recycled at an economic cost. Special appliances also are required to enable the separation of the components, and the recovery of the solvent to be effected with the greatest economy.

A mixed solvent is much favoured at present. This consists of methyl ethyl ketone and benzene. The ratio of the hydrocarbon to the ketone may run as high as 10 to 1, and a mixture of benzene-toluene may be employed. The reason for the selection of the ketone is mainly on account of its solvent power on the oil combined with a low solubility of wax at low temperatures. But most oils associated with wax in wax distillate cuts are not completely soluble in the ketone and, for this reason, benzene or benzene-toluene is added. Other ketones have also been employed, e.g., acetone and methyl propyl ketone.

Ethylene dichloride is also employed and also methylene-ethylene chloride mixture.

The method of conducting the separation varies widely. Thus, the solvent may be added to the molten wax distillate and the mixture either slowly or shock chilled. The wax distillate may be partially chilled until wax starts to separate, and then the solvent added and cooling continued to the desired point. In all cases, of course, the chilling of the mixture is carried down to the temperature necessary to give a solvent-free residue of the desired set point. The mixture is filtered at this temperature on a continuous rotary filter, washed, and the wax cake with the remaining solvent removed. The washed wax-cake plus solvent is usually "repulped" at the same temperature with solvent and again filtered and washed. In certain in-

stances, recrystallisation may be carried out. Various alternatives clearly exist for concurrently effecting a solubility separation (and therefore a setting-point separation) of the wax constituents, by de-oiling at a series of falling temperatures, or by total de-oiling in one stage, followed by re-running the de-oiled wax at a series of falling-temperatures.

Economies are effected by utilisation of wash liquors instead of fresh solvent at suitable points in the process, by effecting as complete recovery as possible of the solvent (less than 0.04% loss out solvent turnover is claimed), and by taking advantage of heat exchangers wherever possible.

*Finishing Treatment of Paraffin Waxes.*

The refined paraffin waxes obtained from the processes outlined above are substantially oil-free (i.e., should contain less than 0.3%), but they are generally very slightly yellowish. Products from pressing and sweating may also have a slight odour. They are therefore given a finishing treatment to remove residual colour and odour. Percolation through, or agitation with, an adsorptive earth may be employed (i.e., special grades of Fullers' earth and bauxite); sulphuric acid treatment, followed by neutralisation, is also practised. The finished wax should be colourless and odourless, and not show a tendency to become yellow or dark in storage or when exposed to light.

Finally the waxes are slabbed by casting in open presses or more usually, shock chilled in water-cooled press moulds. The slabbed wax, which may then be cotton covered, is placed in good quality gunny or hessian bags.

The setting-point grades normally available in Great Britain are 106.7-108°F., 110-112°F., 112-115°F., 118-120°F., 122-125°F., 125-130°F., 130-135°F., 135-140°F., 140-145°F., 146-150°F., and occasionally higher up to 160°F. In general the price rises with the setting point.

"White Scale" or "Scale Wax" is also normally available. It is slightly less refined (*vide supra*) containing somewhat more oil (up to 5% but usually from 1 to 2%) and being often of a slightly yellow colour. It may be sold slabbed or as pressed flakes in wooden drums, and is cheaper than paraffin wax.

**B. Petrolatum Waxes and Petroleum Ceresins (Micro crystal line and Amorphous Waxes).**

As has been stated above, petrolatum waxes and petroleum ceresins are usually obtained from distillation residues of some crude oils. Such residues are a highly complex mixture of high molecular-weight hydrocarbons. For example, a wax-bearing residue will probably be a mixture of asphaltic materials, petroleum resins, high molecular-weight oils and waxes, which latter will range in setting point from about 35° to 100°. Resolution of such residues into their commercially valuable constituents is considerably more complicated than the resolution of a wax distillate, and the residue from a given crude oil represents a special problem, generally requiring a special study on its own. The wax contents also vary considerably for

different residues (from nil to 40% or over). Some residues may contain waxes mainly of the petrolatum wax type and other waxes mainly of the petroleum ceresin type; thus, no reliable generalisations are possible.

One method that may be applied to many such residues (with suitable modification to suit the special properties of each) is first to de-asphaltise and de-resinify the residue with liquid propane, and then to extract the treated residue with a suitable solvent (e.g., phenol). The refined residue, which will now consist essentially of a mixture of heavy oil and wax, is treated by the solvent de-waxing or de-oiling process described above. The crude wax cakes are then re-run if further purification is desired.

The waxes obtained are quite different from ordinary paraffin wax (*v. supra*). They are not so readily obtained as white products, due to the cost of removing last traces of colour. An interesting difference between petrolatum waxes and petroleum ceresins on the one hand and paraffin wax on the other, is that the latter are markedly affected by the presence of relatively small quantities of oil; e.g., 0.75% of oil in a refined paraffin wax will have a very adverse effect on the mechanical properties and render it crumbly, whereas most petrolatum waxes and petroleum ceresins can hold 5% of oil or more without any apparent effect.

#### METHODS OF TESTING.

The official methods of testing petroleum waxes are laid down in the book of "Standard Methods" published by the Institute of Petroleum and the A.S.T.M. Standards Book. Reference to these books should be made for details of test.

For paraffin wax, the following tests are usual:

- (i) Setting Point: derived from a cooling curve—I.P. 55/44.
- (ii) Colour: usually measured by the Lovibond Tintometer in Great Britain in an 18-in. cell and with the 510 Yellow series and the 200-Bed series of glasses (I.P. 17/45). A properly refined wax should have a colour of about 1 Y.U. in this cell.

The A.S.T.M. Handbook details a standard method of test for Oil Content of Paraffin Wax (A.S.T.M. Designation D.721-44). This method has not yet been adopted in Great Britain.

One of the difficulties of oil-content determination is that the extracted oil contains a greater or less proportion of wax. Thus, oil extracts from wax may exhibit setting or congealing points (I.P. 76/44T), of weight over 15%. In this writing, oil is taken as the quantity of oil extract obtainable of a congealing point of 13-15%.

For petrolatum waxes and petroleum ceresins no special standard tests are described except the congealing point (I.P. 76/44T). The test covers those cases where the setting point is too ill-defined by other methods to give any result.

It will be evident from the above that very few standard tests are available for petroleum waxes. In practice, other tests are frequently employed; these will be dealt with where necessary under the heading of "Properties" below.

#### COMPOSITION OF PETROLEUM WAXES.

(i) *General*.—As far as the paraffin wax group is concerned, all published work on the subject is agreed that the components occurring in preponderating quantity are the solid members of the n-paraffin series of setting point roughly from about 15% (say C<sub>16</sub>) to about 70-75% (say C<sub>35</sub>). This remark is a general one and does not necessarily apply to any special setting-point grade where the setting-point range is intentionally limited.

Further, it may be taken as well established that petroleum waxes also contain smaller amounts of solid members of other series of saturated hydrocarbons. It has not yet been established with any certainty what these series are, beyond the purely general statement that they appear to consist of branched chain paraffins, and also of solid saturated cyclo hydrocarbons. No individual has been separated in sufficient quantity for exact identification. The evidence for the presence of these series is based on the fact that concentrates that differ markedly in physical properties from n-paraffins of the same setting point, molecular weight, or boiling-point, may be separated from paraffin waxes by purification by fractional distillation alternated with recrystallisation from suitable solvents. In certain instances, properties of such concentrates are best accounted for on the supposition that a portion at least is of the solid cyclic-paraffin class; such properties include, for example, the results of ultimate analysis, and the observation that such a concentrate may have a viscosity substantially higher than a n-paraffin of the same molecular weight.

Considerable discussion has taken place over the crystalline form of paraffin wax, e.g., the reason as to why it may crystallise as plates or needles. Buchler and Graves attributed the difference to the presence of an "impurity" (the concentrate of solid saturated hydrocarbons other than n-paraffins) which they termed "soft wax." The term appears an excellent one, inasmuch as the most obvious difference between this concentrate and mixtures of n-paraffins is that the former is always very much softer.

Ferris, Cowles, and Henderson, by fractional distillation and recrystallisation processes, isolated three different types of fractions which showed three different modes of crystallisation. Most gave plate-type crystals; another group crystallised as needles, and the third assumed forms that could not be identified. These were termed "malcrystalline."

It was concluded that the plate type crystals represent n-paraffins, and the needle and malcrystalline, the "soft wax" of Buchler and Graves.

In an interesting more recent paper, Ferris and Cowles suggest that the n-paraffins crystallise as plates, the cyclo hydrocarbons as needles (fractions of lowest setting point) and those of intermediate setting point—possibly branched chain paraffins—form mal crystals. If the types are mixed, and the solubility relations are such that more than one type can crystallise simultaneously, either the needle or mal can impress its form on the plate.

In the case of petrolatum waxes and petroleum

ceresins, the position is more obscure, partly because such mixtures are even more complex than the paraffin-wax group, partly because of the difficulty of satisfactory purification of these waxes, and partly because a sufficient number of pure synthetic hydrocarbons of these ranges (mol. wt. over 450) have not been available for comparison. However, by such separations that have been accomplished,<sup>8</sup> and by inference from various physical properties, it appears that with these groups also, the Ti-paraffins and other solid saturated hydrocarbons occur, although there seems to be a tendency for many crude oils to yield waxes from their residues which contain a preponderating quantity of solid hydrocarbons of other series, and smaller quantities of the n-paraffin series (e.g., waxes of the petrolatum-wax group).

(ii) *Composition of Commercial Grades of Paraffin Wax.*—Grades of paraffin wax are commercially available to certain setting-point specifications; e.g., a grade termed 125-130 (i.e., 51-54°c.). Such grades have a setting point intermediate between the specified limits, e.g., a 125-130 grade wax may have a setting point of 128-3°F.

Such grades have been prepared from a crude oil (or shale oil), probably by one of the two

processes described above, whereby a solid hydrocarbon mixture of the specified setting point has been separated from other waxes present in the crude oil. The range of constituents it contains is therefore less than the total range of solid hydrocarbons contained in the parent crude oil. Such a paraffin wax will, therefore, consist of a range of n-paraffins and solid hydrocarbons of other series in substantially smaller quantities, which have a mean, or average, setting point between the limits quoted.

There is little published data giving information on the approximate ranges of components which comprise each commercial grade. The data given in Tables II and III below are therefore presented. Table II refers to the 112-115°F. grade and Table III to the 145-150°F. grade. The first refers to a wax separated from Burma crude oil, and the second to a wax from Assam crude oil. Both waxes were obtained by the pressing-sweating sequences of operation. The yields given are approximate and the separation was not carried very far. However, the data should be sufficient to show that the range of setting points in each grade is considerable. Further resolution would, of course, have shown even a wider setting-point distribution of constituents.

TABLE II.—RESOLUTION OF A COMMERCIAL WAX, SETTING POINT 46-6°c. (FROM BURMA CRUDE OIL), INTO REACTIONS BY DISTILLATION AND RECRYSTALLISATION.

Fraction by distillation at 2 mm. through fractionating column.	Setting point, °c., of fraction.	Setting point, °c., of components after crystallisation from solvent.	Yield, % weight on starting material.	*
1 . . . . .	34.0			Refractive index and density measurements indicated that these fractions consisted of n-paraffin mixtures.
2 . . . . .	<b>8W</b>		10.1	
3 . . . . .	41-6		10.4	
4 . . . . .	42-6		<b>10.1</b>	
5 . . . . .	44-7		10.7	
6 . . . . .	46-7			
Crystallised from benzene C		<b>47-6</b>	7.5	
F		<b>42-8</b>	2.5*	
7 . . . . .	<b>41H</b>			
Crystallised from benzene C		50-4	8.0	
F		42.1	20*	
8 . . . . .	51.0			
Crystallised from benzene C		<b>51.1</b>	6.6	
F		<b>44-7</b>	3.4*	
Residue . . . . .	53.0			
Crystallised from benzene C		58.0	<b>10.7</b>	
Methyl ethyl ketone C*		42.5	6.8*	
Filtrate liquor, oil . . . . .		—	2.4	

C: solvent-free crystals; V: solvent-free wax from nitrate.

\* Concentrates of solid saturated hydrocarbons other than n-paraffins 14.7%.

Properties of purified filtrate wax from residue:

Setting point . . . . . 42.5°c.  
Mol. weight . . . . . 423  
»D. . . . . 1.4461.

TABLE III.—RESOLUTION OF A COMMERCIAL WAX. SETTING POINT 63-4°C, FROM ASSAM CRUDE OIL, INTO FRACTIONS BY DISTILLATION AND RECRYSTALLISATION.

Fraction by distillation at 2 mm. through a fractionating column.	Setting point, °C.	Setting point, °C. Of pohnents after crystallisation from solvent.	Yield, % weight on starting material.
1 . . . . .	53-6		10
2 . . . . .	58-8		10
3 . . . . .	61-5		10
4 . . . . .	63-0		10
5 . . . . .	63-5		10
6 . . . . .	65-1		10
7 . . . . .	65-7		10
8 . . . . .	67-1		10
Residue Recrystallised from benzene (solvent-free)	69-4		
Filtrate extract, waxy oil		70-4	17-4
		41-0	*6

The fraction isolated as solid saturated hydrocarbons other than n-paraffina can be only taken as a concentrate, and therefore the actual quantity of such components would be less than the combined total given (Table II). A pure n-paraffin of about the same setting point as the purified filtrate wax from the residue (i.e., setting point 42-5°F.) would be about C<sub>21</sub> or C<sub>2a</sub> of a molecular weight of about 300 and n<sub>D</sub><sup>20</sup> 1-4300. It will also be noted that the highest setting-point paraffin wax (Table III) is comprised substantially of n-paraffins. It appears usual for waxes separated by pre- and re-crystallising to contain less solid components, other than n-paraffins, as the setting point rises."

PHYSICAL PROPERTIES.

In view of the fact that petroleum waxes appear to consist in the main of the n-paraffin series, it is only natural to find that the properties of such waxes conform in a greater or less degree to the properties of this series. Nevertheless, these properties are often much modified, due to the fact that commercial waxes are wide mixtures of the n-paraffins and that they may also contain solid saturated hydrocarbons of other series. In general, however, the complexity of the mixture of the n-paraffins appears to account more for such deviations than the presence of other saturated series; for example, fractions of n-paraffins mixtures freed from other solid components will, when suitably blended, give a product not distinguishable from a normal grade of paraffin wax.

(i) *Setting Point.*—This has already been covered under various sections above.

(ii) *Transition Point.*—It is well known that the pure solid n-paraffin of the setting-point ranges" covering commercial waxes have a transition point a few degrees below the setting point.<sup>10, 11, 12, 13, 14, 15</sup>

It has also been found that a few commercial Paraffin Waxes exhibit transition as measured by variation of density in the ranges between the setting point and 15°C.,<sup>16</sup> by thermometric observation,<sup>17, M, 19</sup> and by variation of other properties such as electrical resistance<sup>20</sup> and solubility.<sup>16</sup> Transition points of commercial paraffin waxes are always substantially lower than the transition point of a pure n-paraffin of the same setting point. The onset of transition effects during cooling appear also to be partly responsible for the changes in appearance of a paraffin wax as it solidifies.

In most cases paraffin waxes do not show a transition point by thermometric methods<sup>11</sup> and it appears as if only a fraction or none undergoes transition on cooling. This probably accounts for some of the divergences observable between recorded solid properties of waxes of the same setting point (e.g., the wide variations in the latent heats of fusion). It appears that the more complex the mixture comprising the commercial wax, the further is the transition point depressed, and the smaller the extent to which transition occurs. Many waxes at normal temperatures appear to be in the high temperature stable form, and this partly accounts for their translucency and plasticity (although the plasticity often appears more dependent on components other than n-paraffins).

The subject of the polymorphism of the n-paraffins is an extensive one, and the original literature should be consulted for further details.<sup>10, 11, 12, 13, 14</sup>

(iii) *Specific Gravity.*—(a) *Liquid State.*—The specific gravity of petroleum waxes varies both with the setting point, the crude oil from which they are obtained, and the method of production. The value of p<sup>TM</sup> of commercial paraffin waxes of setting points ranging from about 48 to 60°C. may be taken as ranging from about 0-7700 to 0-7850 (i.e., very roughly 0-0020-0-0080 above the density of the n-paraffins of the same setting point). The petrolatum waxes and petroleum ceresins have a substantially higher density, namely from about 0-8000 to 0-8500.<sup>21</sup>

A mean value of temperature coefficient for all waxes may be taken as approximately 0-0007 per degree c.

(b) *Solid State.*—The determination of the density of waxes in the solid state needs special precautions due to the fact that air is readily occluded in the wax.<sup>16, aa</sup>

The variation of density of wax in the solid state with temperature may show discontinuities due to the transition effect referred to above.<sup>16</sup>

Some typical values at 15-6°C. are:<sup>22</sup>

TABLE IV.—DENSITY OF SOLID PARAFFIN WAX AT 15-6°C.

Setting point, °C.	Density.
49-4	0-897
53-2	0-909
55-0	0-909
60-8	0-911
67-6	0-914

(iv) *Refractive Index (in the Liquid State).*—This is a readily determined property of considerable use in classifying petroleum waxes, but the method of classification described below only applies if the wax is substantially free from oil. The refractive indices of the pure *n*-paraffins are available from the literature and the observed values of commercial waxes may be directly compared with them.<sup>23,44</sup> The relationship between  $n_D^{20}$  and the setting point in °. of a *n*-paraffin may be calculated from the formula:

$$n_D^{20} = 0.0004275(x \text{ setting point, } ^\circ\text{o.}) + 1.4113$$

(derived from data given by M. P. Doss<sup>48</sup>).

The refractive indices of petroleum waxes increase with rise of setting point, and also increase as the content of series other than *n*-paraffin increases. A commercial wax always has a higher refractive index than a *n*-paraffin of the same setting point, the difference for a paraffin wax being between 0.0005 and 0.0050. Providing the petroleum wax is substantially oil-free it may be inferred that the greater its difference in refractive index from that of a *n*-paraffin of the same setting point, the greater its content of solid saturated hydrocarbons other than *n*-paraffins; but there is, as yet, no quantitative relationship known.

The refractive indices of petroleum ceresins and petrolatum waxes (particularly the latter) may be 0.0050-0.0200 higher than that of the *n*-paraffins of the same Jetting points.

Examples of actual values are given in the Table below.<sup>21</sup>

TABLE V.—SETTING POINTS AND REFRACTIVE INDICES OF PETROLEUM WAXES.

Setting point, °.	Refractive index, 60°C Corrected where necessary.
49-4	1.4349
52-2	1.4352
55.0	1.4355 } Paraffin Waxes.
57-8	1.4370
60-6	1.4394
63-4	1.4531
71-8	1.4570 } Petrolatum Waxes.
71-4	1.4442 } Petroleum Ceresin.

Temperature coefficient may be taken as 0.0004 per degree c.

(v) *Solubility.*—The solubility of petroleum waxes varies very considerably even for waxes of the same mean setting point and molecular weight, depending on the composition of the wax mixture. Figures available, therefore, only apply to the actual wax mixture for which the determination was made.

Various trends may be noted. For the paraffin wax group, the solubility in any given solvent decreases as the setting point of the wax rises. Waxes are in the main most soluble in

hydrocarbons and halogen-substituted hydrocarbons. Good solvents for purification are benzene, ethylene dichloride, and methyl ethyl ketone (for waxes containing oil or solid saturated hydrocarbons other than *n*-paraffins in substantial quantity). Ethylene dichloride is a good solvent on account of its very steep temperature solubility curve for wax. J. W. Poole<sup>24</sup> gives a good general summary on the solubility of the paraffin wax group in various organic solvents. It is concluded that, for any solvent, the solubility of wax may be expressed by the general equation:

$$\log W_s = A(\log T - K_s)$$

where  $W_s$  = g. of wax per 100 g. of solvent,

$A$  = constant dependent on the wax,

$T$  = absolute temperature,

$K_s$  = constant depending on solvent.

For the wax employed,  $A = 38.5$ . This wax was of an American wax of commercial origin, setting point 56.0°. It was also split into two approximately equal fractions of setting point 53.9° and 47.3° respectively. Various values of  $K_s$  are quoted from which, the following have been selected:

TABLE VI.—VALUES OF  $K_s$  FOR VARIOUS SOLVENTS.

Solvent.	$K_s$
Acetone	2.4792
<i>n</i> -Amyl alcohol	2.4700
Chlorobenzene	2.4351
Chloroform	2.4240
Ethylene dichloride	2.4650
Light petroleum	2.4277
Toluene	2.4307

The solubility of paraffin wax in pure hydrocarbons has been determined for a fraction obtained from a commercial paraffin wax by careful recrystallisation from benzene.<sup>85</sup>

TABLE VII.—SOLUBILITY OF PURIFIED PARAFFIN WAX (SETTING POINT 56°C,  $\rho = 0.776$  Q. 100 o.c. SOLVENT.

Temperature, °C.	Pen- tane.	Hexane.	Hep- tane.	Octane.	<i>iso</i> - Decane.
0	—	2.77	1.37	0.99	—
5	—	3.69	2.18	1.69	0.94
10	5.11	4.81	3.55	2.90	1.44
15	6.94	6.07	5.06	4.24	2.74
20	9.53	8.31	7.18	5.93	4.98
25	17.16	16.23	14.36	11.66	9.17

Figures for the solubility of a refined wax (setting point 125-127°F.) of American origin in various solvents are given in Table VIII.<sup>21</sup>



TABLE VIII.—SOLUBILITY OF 125-127°F. (51-53°o.) PARAFFIN WAX IN VARIOUS SOLVENTS.

	Percentage wax in solution.					
	15°5' O.	21°1' O.	26°7' c.	^2-2°C.	37-8°C.	433° O.
Benzene.	100	180	350	56	77	90
Carbon tetra-chloride	100	150	310	48	68	83
Ethylene dichloride	0*2	0*8	re	7	30	

The solubility of paraffin wax in various petroleum fractions is given by D. S. Davis.<sup>26</sup>

It may also be noted that, as would be anticipated, the solubility of the high-temperature stable form of paraffin wax (see "Transition Point" (ii)) is more soluble than the low-temperature stable form.<sup>16</sup>

(vi) *Latent Heat of Fusion.*—The latent heats of fusion of the pure n-paraffins covering the ranges present in paraffin wax (C<sub>21</sub>-C<sub>36</sub>), run from about 37.5 to 42.0 g.-cal. for the high-temperature stable form and from about 69.5 to 64 g.-cal. for the low-temperature stable form.<sup>6, u</sup> This gives a heat of transition of about 22 g.-cal. Latent heats of fusion of commercial paraffin waxes are substantially lower than this.

TABLE IX.—HEATS OF FUSION OF VARIOUS COMMERCIAL WAXES.

Setting point, °o.	Latent heat of fusion, g.-cal.	References.
51-7	40*3	(2)
52-2	38-9	(3)
52-4	35-1	(4)
65-3	43-8	(5)

Even intensive purification of fractions from commercial paraffin does not realize the values obtained for the pure n-paraffins. For example, G. S. Parks and S. S. Todd<sup>30</sup> give latent heats of fusion of fractions obtained from petroleum by Buchler and Graves<sup>6</sup> and considered to be C<sub>20</sub>, C<sub>21</sub>, C<sub>22</sub>, C<sub>23</sub>, C<sub>24</sub>, C<sub>25</sub>, C<sub>26</sub>, C<sub>27</sub>, C<sub>28</sub>, C<sub>29</sub>, C<sub>30</sub>, C<sub>31</sub>, C<sub>32</sub>, C<sub>33</sub>.

TABLE X.—LATENT HEATS OF FUSION OF HIGHLY PURIFIED WAX FRACTIONS FROM PETROLEUM.

Number of carbon atoms.	Setting point, °c.	Latent heat of fusion, g.-cal.
20	36-4	520
25	53-3	53-6
33	71-1	540

For Tables of Heat Content and Heat of Solution, see U.S. Bureau of Standards Publication 9745, 1929.

(vii) *Specific Heat.*—Specific heat in the solid state of paraffin wax may be taken as 0\*5,

although higher values may occur near the setting point.

Specific heat in the liquid state is given, approximately, by  $c=0.492+0.0009J^{\circ}o.$  between the setting point and 300°o.

(viii) *Heat Conductivity.*—The heat conductivity in the solid state increases with temperature from about 0.00023 at 0°o. to 0.0006 at 25°o. in units of g.-cal. per sec. per cm.<sup>8</sup> per °o.

(ix) *Electric Properties.*—Inasmuch as petroleum waxes are frequently used for insulation and as dielectrics, some statement is necessary regarding their electrical properties. Very little published work exists, however, on this subject.

TABLE XI.—DIELECTRIC PROPERTIES OF PARAFFIN WAX (FROM I.C.T.).

Resistivity, p, ohms per cm. cube.	$10^{16}-5 \times 10^M.$
	8, kv. per mm. . . . . 10-50.
Dielectric constant . . . . .	1-9-2*3.

Lee and Lowry<sup>31</sup> give some electrical properties of a paraffin wax and a wax of the mixed petrolatum wax and petroleum ceresin type.

TABLE XII.—ELECTRICAL PROPERTIES OF A PARAFFIN WAX OF AMERICAN ORIGIN (SETTING POINT 51.7°C, pf 0-774) AND A MICROCRYSTALLINE WAX, "SVPERLA" (SETTING POINT 74°o., pf 0-937, AT 24°O.) WITH A FREQUENCY OF 1,000 CYCLES PER SEC.

	paraffin wax, setting point 51.7°C.	Microcrystalline wax, "Superla," setting point 74°C.
Dielectric constant. . . . .	2-19-2-24	2-32-2-35
Effective A.C. conductivity (unit=10-12 ohm per cm.) . . . . .	<0.37	4-2-4-6
Volume resistivity (unit =10 <sup>13</sup> ohm per cm.) . . . . .	>290	>460

Jackson<sup>82</sup> gives a value of 2-18 for the dielectric constant for a paraffin wax of Asiatic origin, setting point 57°c, at a frequency of 10<sup>7</sup> c.p.s. and a temperature from 10-25°c.

Jackson<sup>80</sup> has explored various electrical properties of paraffin wax, including the D.C. conductivity. For a paraffin wax, setting point 57-60°c, (of Asiatic origin) he finds the D.C. conductivity varies from 10<sup>-17</sup> mhos per cm. at 0°c. to 10<sup>-11-6</sup> at 47°c, and for a highly purified fraction of paraffin wax (from Burma crude oil, setting point 55°c), it varied from 10<sup>-17-3</sup> at 0°c. to 10<sup>-13\*7</sup> at 55°G. The curves fell to a minimum about 10-15°o. below the setting point, and then rise to a maximum, and there, after fall as the temperature decreases (Jackson plots log mhs. per cm. against temperature). The development of the minimum about 10-15°c. below the setting point is attributed to transition effects in the paraffin wax.

(x) *Mechanical Properties of Petroleum Waxes in die Solid State.*—It is becoming increasingly frequent to test mechanical properties of

petroleum waxes. It is known that several special tests are employed by large producers and consumers but the details have not yet been published.

They fall into three main categories:

- (a) Penetration and Hardness Tests.
- (b) Tensile Strength Tests.
- (c) Rupture Tests.

It may be said that these tests make some endeavour to measure mechanical properties that are considered to be of value from the standpoint of wax application. They are difficult to interpret, the value of such testing being mainly of an empirical nature. However, it appears that all such tests are much influenced by variation of temperature, presence of oil, and composition of the wax mixture.

#### (a) Penetration and Hardness Tests.

A needle-penetration test is gaining in popularity for the assessment of waxes of the petrolatum wax and petroleum ceresin type. This test is the A.S.T.M. D.5-25 and the I.P. 49/46. The result is expressed as the distance (in tenths of a millimetre) that a standard needle vertically penetrates the sample under known conditions of loading, time, and temperature. For paraffin waxes, tested at 90°F., the value of the penetration varies from about 250 for a wax of setting point 51°0. to 12 for a wax of setting point of 60°C.<sup>21</sup>

For waxes of the petrolatum-wax type and petroleum-ceresin type, the published penetration values at 77°F.\* vary from about 25 for the former to 12 for the latter,<sup>21</sup> but it is probable that other recent additions of waxes of these types would show even wider variations.

A hardness test (devised and employed by the Burmah Oil Co., Ltd.) consists in measuring the depth to which a 60° cone penetrates a specially cast sample of the wax, when under a load of 1,500 g. for 30 seconds. The hardness number is calculated as the load in kg. per sq. cm. (*i.e.*, Standard Brinell practice). Table XIII below gives the variation of hardness of an oil-free commercial paraffin wax with incremental additions of the oil normally associated with it.

TABLE XIII.—VARIATION OF CONE HARDNESS WITH OIL CONTENT.

Percentage oil by weight.	Commercial wax, setting point 53.3°C.	Commercial wax, setting point 59.1°C.
	Hardness at 15°C.	Hardness at 15°C.
0	62.8	79.7
0.25	61.9	69.4
0.5	56.6	64.2
0.75	52.8	56.9
1.0	47.2	53.5
1.5	41.6	46.2
2.0	39.6	46.5

The effect of temperature on hardness by this method of two commercial waxes of widely different setting point is given in Table XIV.

TABLE XIV.—VARIATION IN HARDNESS OF TWO COMMERCIAL WAXES WITH TEMPERATURE.

Temperature, °C	Middle Eastern wax, setting point 53.1°C.	Assam wax, setting point 63.4°C.
15.5	61.4	70.2
18.3	51.8	—
21.1	44.4	73.1
23.9	36.5	—
26.7	22.2	56.1
29.4	9.68	43.0
*32.2	3.90	38.7
35.0	—	36.0
37.8	—	31.8
40.5	—	24.0
43.3	—	23.1
46.1	—	15.2
48.9	—	5.87

#### (b) Tensile Strength Tests.

A tensile strength test is described by Seyer and Innouye<sup>22</sup> who found that waxes examined by them behaved as plastic solids at over 30°C.

Espach<sup>33</sup> describes the Perkins Tensile Tester as employed for waxes and gives data on the effect of oil on tensile strength.

Bennett<sup>21</sup> gives value of tensile strength (in lb. per J sq. in. area) at 90°F. for a variety of waxes. The values range from nil to over 60 but do not bear any obvious relationship to the setting point or any other quoted value.

#### (c) Rupture Tests.

These tests consist essentially of loading a strip of the wax under test and measuring the conditions under which it fractures.

A rupture strength test (devised and employed by the Burmah Oil Co., Ltd.) loads, at a constant rate, four test strips cut from a 6 g. cake of the wax sample (1J in. by 2) in.). The weight required to break each test piece and also the deflection before fracture are observed, and a conventional velocity of bending calculated from the latter.

Table XV shows the variation of rupture strength of two fully de-oiled commercial paraffin waxes with increments of the oil normally associated with them.

TABLE XV.—VARIATION OF RUPTURE STRENGTH (IN O.) WITH OIL CONTENT AT 15.6°0.

Percentage of oil added.	Fully de-oiled commercial 125/30°F. grade.	Fully de-oiled commercial 135/40°F. grade.
0.1	345	304
0.1	278	245
0.2	236	214
0.3	188	177
0.4	183	159

The effect of temperature on the velocity of bending for the same waxes is given in Table XVI.

TABLE XVI.—VARIATION OF VELOCITY OF BEND OF RUPTURE TEST STRIP WITH TEMPERATURE (HUNDREDTHS MM./MIN.).

Temperature, °c.	Fully de-oiled commercial 125/30°F. grade.	Fully de-oiled commercial 135/40°F. grade.
4.4	31	26
100	43	31
15-6	77	46
21-1	191	74
26-7	565	156

CHEMICAL PROPERTIES.

Although paraffin wax is usually stated to be chemically very stable, a fact to which the name "paraffin" is due, the literature on the chemistry of commercial wax is so vast that only the briefest review is possible. The literature is, however, comprehensively summarised by Ellis.<sup>1</sup>, w

Briefly the three general fields of investigation have been

- (i) Oxidation,
- (ii) Halogenation.
- (iii) Thermal decomposition.

U) Oxidation.

In the main, investigations have followed the line of oxidation at moderate temperatures (100-200°o.) either at atmospheric or high pressure in the presence of catalysts and using either air or oxygen. A vast number of catalysts have been employed and various claims for their efficacy have been made. The object of these investigations has been the possibility of fatty acid production. Fatty acids have been made on the commercial scale by this means, and have been employed for soap making and for the manufacture of edible glycerides in Germany and Russia. The reaction normally produces a variety of products, including fatty acids, hydroxy acids, unsaturated acids, ketones, aldehydes (both saturated and unsaturated), lactones, etc. So far, however, only the rigours of war or abnormal economic conditions have justified its commercial operation. Many problems remain to be solved before paraffin wax can be regarded as a suitable raw material for fatty acid manufacture.

(ii) Halogenation.

Chlorination is quite simply carried out on petroleum waxes by passing chlorine through the molten wax held at a temperature preferably not less than 60°o. or more than 250°c. A variety of catalysts have been named as desirable; and the chlorination may be accelerated by the choice of a suitable solvent {e.g., carbon tetrachloride<sup>36</sup>}.

The chlorination is stopped when the desired increase in weight has been realised. The position of entry of the chlorine into the hydrocarbon molecule has not yet been really successfully controlled, although certain claims in this direction have appeared. Chlorinated waxes are complex mixtures of unknown composition. They have, however, certain commercial uses:

(a) Preparation of a " Pour-Point depressant " by a reaction between the chlorinated wax and an aromatic hydrocarbon in the presence of aluminium chloride. A trade name for such a product is " Parafflow " and it has the effect, with certain classes of oil, of depressing the temperature at which wax separates.

(b) For fireproofing.

(c) As " Extenders " for plastics.

Bromination is stated to be more difficult than chlorination.

Fluorination of paraffin wax has been carried out by dissolving chlorinated paraffin in benzene and treating it at the boiling-point with a mixture of antimony trifluoride and antimony pentachloride.<sup>37, M</sup> The product may be used as a dielectric.

(iii) Thermal Decomposition,

Petroleum wax decomposes rapidly at a temperature in excess of 450°c. into simpler paraffins and olefins. The olefins may be suitably extracted from the reaction mixture. The mixture is, of course, highly complex.

A very large number of chemical reactions are clearly possible with such olefinic mixtures.

A commercial application of this reaction was employed during the war in Germany when very large quantities of lubricating oil were made from paraffin wax by its thermal decomposition in the presence of a catalyst (e.g., aluminium chloride) and condensation to high molecular-weight oils.

UTILISATION.

Paraffin wax is mainly a commercial use on account of its properties in the solid state. These arise because of the complexity of the mixture of hydrocarbons that compose it. Sharply fractionated wax—where such fractionation proceeds by distillation and recrystallisation of refined paraffin wax—is of little use, because such fractionated products are far too crystalline and easily disintegrate.

Prior to 1939 the world consumption of paraffin wax had reached 500,000 tons per annum. The distribution of this demand in Great Britain is detailed in Table XVII.<sup>39</sup>

TABLE XVII.—DISTRIBUTION OF PARAFFIN WAX AMONG VARIOUS APPLICATIONS.

Application.	Percentage of application of total.
Candles, night lights, and tapers	64
Waxed paper and cartons	15
Polish materials	10
Matches	5
Electrical insulation	3
Various other applications	3

Bennett<sup>21</sup> states, writing of the American market, that the approximate distribution of paraffin wax is 80% for coating and impregnating paper and paper products, 10% for candles, and 10% for other applications. Although, as Bennett indicates, these figures are difficult to

check, it is evident that the American demand for wax for coating and impregnating paper and paper products is far in excess of this utilisation in Great Britain. It seems probable that in more normal times the British off-take in this direction is likely to show a very considerable increase.

The volume and applications of petroleum ceresin and petrolatum waxes is at the moment obscure. The quantities available to the market have increased sharply over the war years. As far as can be ascertained the main use has been for coating and impregnation, and not only of paper and paper products, but even of tools, machine spares and so forth. It is claimed that products so coated stand up excellently to severe tropical conditions of humidity. The petroleum ceresins appear to be utilised mainly for electrical purposes and in the formulation of polishes and of pharmaceutical preparations and cosmetics.

(i) *Candles, etc.*—The utilisation of paraffin wax for this purpose is based on the fact that when burnt under suitable conditions, it burns with a clear, nearly white, smokeless and odourless flame.

According to Allan<sup>80</sup> \*\* the quality of the wax most suitable for candle-making depends on the market to be supplied. If the wax has too high a setting point (*e.g.*, above 130°r.) lighting difficulties may be encountered; and if the setting point is too low (*e.g.*, below 120°F.), the wax is too plastic and the candle may become distorted or bend in storage or in use. Actually the composition of the WAX is adjusted by suitable blending of waxes of different setting point, and by the addition of stearine (or other wax-like or organic materials). Stearine has various advantages; for example, it tends to offset the plasticity of some waxes and it increases the opacity of the candle. The most usual proportion in which it is added is from 3 to 5%.

Since waxes of the same setting point may vary considerably in their plasticity, due to the different ranges of solid saturated hydrocarbons they contain, it is evident that waxes from different sources will vary considerably regarding their suitability for candle manufacture.

The wick is adjusted to give proper consumption of wax according to the diameter of the candles.

The following table gives approximate consumptions aimed at for candles of different diameter. They apply to a wax of 123-125°F. setting point with 3.5% of stearine.

TABLE XVIII.—DIAMETERS OF CANDLES AND CONSUMPTION.

Diameter in Inches.	Consumption, g. per br.
<i>i</i>	4-86-5-18
<i>1 1/4</i>	6-48-7-13
<i>toil</i>	7-78-8-10
<i>to*</i>	8-10-8-42
<i>toil</i>	8-42-8-75
<i>tol</i>	8-75-9-07
<i>to 1 1/4</i>	9-07-9-40

Wicks employed are mostly plaited in three groups of yarn and so many plaits per inch. These three groups may contain each 6—12 or more strands of cotton and are plaited up to 10 or 12 plaits per inch.

Wicks are chemically treated before use to assist burning. After an initial wash with weak caustic soda, bleaching with weak hypochlorite, and washing with hydrochloric acid and water they are treated with solutions of which the main ingredients may be ammonium sulphate, chloride and phosphate, borax, boric acid, and potassium nitrate.

Details of candle-making plant with illustrations may be obtained from the reference given above (*see also* Vol. II, 263a).

Night-lights are designed to burn for relatively long periods with a smaller illumination and therefore slower consumption. They are made from paraffin wax alone, no stearine being added, and white scale may be blended with the paraffin wax employed. The process of moulding night-lights is similar to that of candles, except that they are made without wicks. In the centre of the mould is a pin which projects nearly to the top and this makes a hole into which a fine cotton wick, coated with a high setting-point wax to stiffen it, is later inserted by hand.

Tapers are made by passing cotton yarn backwards and forwards through a bath of wax, and then through dies, until the desired thickness is attained, thermal conditions are adjusted to ensure that the wax is in a plastic condition when it passes through the dies.

(ii) *Coating and Impregnating of Paper and Paper Products, etc.*—The following excellent summary of these applications is quoted from Gray.<sup>89</sup>

"Modern methods of production and marketing, whereby perishable goods manufactured in one hemisphere may be destined for consumption in the other, have brought with them the need for new and greatly improved wrapping materials, impervious to air, water, and water vapour, odourless, tasteless, physiologically inactive, robust enough and cheap enough to be commercially practicable. Waxed paper and cartons have obvious limitations as regards robustness, but fulfil all the other requirements. For certain applications in which great strength and rigidity are not essential, therefore, their use is extending very rapidly.

"Waxed paper alone may be used as a wrapping material for a great variety of products, such as bread, confectionery, beef-extract cubes, soap tablets, and safety-razor blades. Again, many proprietary materials are packed in unwaxed or lightly waxed cartons or boxes, which are then wrapped and sealed in waxed paper. This method is customary in the case of dry, granular products, such as breakfast cereals, macaroni, salt, etc. It is also commonly used for biscuits. Lastly, liquid or semi-liquid products are conveniently handled in heavily waxed-sealed cartons without any additional wrapping. The last method is familiar in the case of milk, honey, syrup, sandwich pastes, and soon.

"Paper-waxing machinery varies greatly in

design and method of operation, but two basic types may be distinguished, according to whether the wax is applied to the paper by waxed rollers or by total immersion of the paper in molten wax. After waxing, the paper is chilled by cold-water immersion or by passing over chilled rollers.

" In general, rapid chilling produces opaque coatings with high gloss. Impregnation produces translucent papers without pronounced gloss. The finished paper may contain up to about 40% of its total weight in wax.

" Cartons for liquids are made up into their finished shape before waxing. The waxing may be done by total immersion in molten wax, or by simultaneous spraying outside and inside, or, if desired, on the inside only, as the cartons pass the wax jets on a conveyor. After waxing, the cartons are chilled in a refrigerating compartment, or by dipping in cold water, followed by draining and drying.

"As a general rule, only refined grades of paraffin wax, with very low oil contents, are satisfactory for paper waxing. The presence of oil, or inadequate refining, leads to deficiencies such as low sealing strength, flaking, poor gloss, colour- and odour-instability, and " blocking " (i.e., tendency of the waxed surfaces to adhere and flow together when the paper is stacked of rolled)."

Recent years have seen the employment of increasing quantities of the petrolatum-wax group and petroleum-ceresin group for coating and impregnation purposes. The Petrolatum Waxes are particularly favoured on account of their flexibility, imperviousness to moisture, and stickiness. Further, American practice appears to be favouring the principle of specially blending waxes for this utilisation. Indications to the extent to which this may be practised are given in Bennett.<sup>21</sup>

(iii) *Polishes*.—Petroleum waxes are widely employed in the manufacture of polishes.

Paraffin wax is used in admixture with special waxes, such as Carnauba, Candelilla, Ozokerite, and a variety of synthetic waxes (e.g., the I.G. series of synthetic waxes and others). It appears to have a twofold purpose: first, to cheapen the total cost of the wax employed, and secondly, to act as a " plasticiser " on such waxes. "It also plays its part in ensuring that the solvent evaporates at the right rate from the surface to be polished.

The quality of the polish conferred by a suitable wax mixture into which is incorporated a solvent, appears to depend mainly on the other waxes employed. Certain microcrystalline waxes (i.e., waxes of the petrolatum-wax and petroleum-ceresin groups) appear to confer an excellent polish, although here again the employment of such waxes is more often to ensure the right retention of solvent and its correct rate of evaporation.<sup>42</sup>

Wax polishes are of two general types. The first is made with organic solvents, usually white spirit to which turpentine may be added. The desired colour is attained by the use of an appropriate dye. The waxes are melted together in a mixer and the solvent incorporated. The mixture is filled into the containers when the desired consistency is reached.

The second type is made by emulsifying the mixture of waxes, solvent and stabiliser, with water. Many formulae are available (vide Bennett<sup>21</sup>).

(iv) *Matches*.—Matches are impregnated with paraffin wax to assist their kindling and burning. Low setting-point grades are employed, usually 106-108°F., 110-112°p., and 112-115°p. For this purpose the paraffin wax may contain appreciable quantities of oil (up to about 3%).

(v) *Electrical Uses*.—This utilisation takes advantage of the very high resistance of petroleum waxes, and its use is as a dielectric or as an insulating material. It may be used pure or in admixture. It is not sufficiently realised that petroleum waxes undergo oxidation at impregnation temperatures, if these temperatures are too high or the wax is held too long at the temperature in the presence of air. For example, Jackson<sup>32</sup> found that the power factor of fresh paraffin wax at high frequencies was at no point in excess of  $0.5 \times 10^{-4}$  at temperatures from 0 to 80°o., but, after heating in air for 230 hours at 100°o. it had risen to about  $4.7 \times 10^{-8}$ .

Usually it is desirable that a petroleum wax employed for electrical purposes should have a very fine crystalline structure. For this reason paraffin wax may be preferred blended with petroleum ceresin or petrolatum waxes.

Paraffin may also be used as a plasticiser for polythenes.

Specific uses are for condensers and cables.

(vi) *Various other Applications*.—Other uses may be briefly listed as follows:

**Manufacture of Textiles:** Paraffin wax is used to lubricate threads before spinning, for waterproofing, and for calendering after laundering (wax emulsions).

**Leather Trade:** White Scale or slack wax is usually employed for a variety of purposes, of which dressing is the most important.

**Preservation of Food:** Paraffin wax and petrolatum waxes are used for coating fruit, vegetables, eggs, cheeses, hams, and other perishable goods.

**The Arts:** Paraffin wax is used for mounting and strengthening museum and art objects and in the manufacture of crayons, etc., and for modelling compositions.

REFERENCES.

- 1 J. Inst. Petroleum, 1043, 298, 361.
- 2 F. W. Padgett, " Science of Petroleum," Oxford University Press, 1938, III, 1954.
- 3 A. N. Sachanen, L. O. Zherdeva, and A. N. Vasilyev, Nat. Petroleum News, 1931, 23, 16.
- 4 C. E. Reistle and O. C. Blade, U.S. Bur. Mines Bull., 1932, No. 348.
- 5 C. G. Buchler and G. D. Graves, Ind. Eng. Chem. 1931, 23, 681.
- 6 H. A. Miller, H. Cowles, and L. M. Henderson, *ibid.* 1931, 23, 681.
- 7 Mair and Schickltanz, *ibid.* 1936, 28, 1056.
- 8 Gross and Grode, Oel u. Kohle, 1942, 18, 410.
- 9 S. W. Ferris and H. Cowles, Ind. Eng. Chem. 1945, 37, 1064.
- 10 W. E. Garner, K. von Bibber, and A. M. King, J.C.S. 1031, 1533.
- 11 H. A. Müller, Proc. Roy. Soc. 1932, A, 138, 514.
- 12 S. H. Piper, A. C. Chibnall, S. J. Hopkins, A. Pollard, J. A. B. Smith, and E. F. Williams, Biocnem. J. 1931, 25, 2072.
- 13 E. C. H. Eolvoort, J. Inst. Petroleum, 1938, 24, 338.
- 14 W. F. Seyer, R. F. Patterson, and J. L. Keays, J. Amer. Chem. Soc. 1944, 66, 179.

- " C. G. Gray, J. Inst. Petroleum, 1943, 29, 226.  
 " J. A. Carpenter, J. Inst. Petroleum Techn. 1926,  
 13 300.  
 17 H. D. Lord, J. Inst. Petroleum, 1939, 25, 263.  
 18 G. R. Scott Harley, *ibid.* 1939, 25, 238.  
 19 Yannaquis, Ann. combustibles liquides, 1934, 9,  
 295.  
 20 W. Jackson, Trans. Faraday Soc. 1935, 31, 827.  
 21 H. Bennett, "Commercial Waxes/" Chemical  
 Publishing Co. 1944.  
 22 W. F. Seyer and K. Innovye, Ind. Eng. Chem.  
 1935, 27, 507.  
 23 C. R. Scott Harley, "Science of Petroleum,"  
 Oxford Univ. Press, 1938, II, 1191.  
 24 J. W. Poole, Ind. Eng. Chem. 1931, 23, 171.  
 « p. Weber and H. L. Dunlap, *ibid.* 1928, 20, 334.  
 26 D. S. Davis, *ibid.* 1940, 32, 1293.  
 27 F. W. SuUiven, W. J. McGill, and A. French, *ibid.*,  
 1927, 19, 1040.  
 28 Kozicki and Pilat, Petroleum, 1918, 14, 12.  
 29 Batelli, Physik. Z. 1908, 8, 671.  
 30 G. S. Parks and S. S. Todd, Ind. Eng. Chem. 1929,  
 21, 1235.  
 31 Lee and Lowrey, *ibid.* 1927, 19, 302.  
 32 W. Jackson, Proc. Roy. Soc. 1935, A, 150, 197.  
 33 R. H. Espach, U.S. Bur. Mines Bull. 1935, No. 388.  
 34 C. Ellis, "Chemistry of Petroleum Derivatives/"  
 Reinhold, 1934.  
 3\* C. Ellis, *op. cit.*, Vol. II, 1937.  
 36 Buchner, U.S.P. 1129165.  
 37 B.P. 443340.  
 38 B.P. 452656.  
 3» C. G. Gray, "Modern Petroleum Technology,"  
 Inst. Petroleum, 1946, p. 332.  
 40 D. Allan, J. Inst. Petroleum Tech. 1933, 19, 155.  
 41 D. Allan, "Science of Petroleum," Oxford Univ.  
 Press, 1938, IV, 2686.  
 42 L. Ivanovsky, "Ozokerit u. venvandte stoffe,"  
 Hartlebcn's Verlag, Chemische-technische Bibliothek,  
 No. 397.  
 43 M. P. Doss, "Physical Constants of the Principal  
 Hydrocarbons," Texas Co., 1943.  
 44 L. Ivanovsky, "Ozokerit u. venvandte stoffe,"  
 1935, 11. Band, 2 Teil.

EM L. M.

PET UN IDIN is the anthocyanidin which is obtained by the arid "hydrolysis of petunin (*q.v.*). The crude product contains an impurity which renders crystallisation difficult, and which is more easily soluble in alcohol and less easily soluble in aqueous mineral acids than petunidin itself. Purification by adding concentrated hydrochloric acid to a solution in the dilute acid, dissolution of the precipitate in methyl alcoholic hydrogen chloride and slow evaporation of the solution gives petunidin chloride in a well-crystallised condition.

Petunidin chloride forms a number of hydrates which differ in solubility and crystalline form. In appearance these are dark brown or grey-brown in colour. Petunidin chloride, which has been crystallised from aqueous-methyl alcoholic hydrochloric acid by evaporating the alcohol, is easily soluble in 0.5-1%, and considerably soluble in 3% hydrochloric acid. If however the preparation is washed with ethyl alcohol, a change in the character of the hydrate occurs. The new form is stable in air, but it is not only insoluble in 3%, but is almost insoluble in cold 0.5% hydrochloric acid. It is easily soluble in the more dilute acid on warming, and no separation of crystals occurs on cooling. Crystallised from aqueous hydrochloric acid, petunidin chloride forms the *dihydrate*,

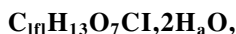

which becomes anhydrous in the desiccator. Washing with alcohol appears to cause the replacement of 2H<sub>2</sub>O by 0.5 C<sub>2</sub>H<sub>5</sub>OH. Dehydration of petunidin chloride by heating to 100° in

vacuum is accompanied by loss of hydrogen chloride.

Petunidin chloride is very easily soluble in alcohol; the solution gives an intense blue reaction with ferric chloride. Aqueous solutions of the chloride are destroyed by ferric chloride. Sodium acetate added to a solution in amyl alcohol gives a violet-blue colour. The chloride is not extracted from aqueous solutions by shaking with a mixture of cyclohexanol (1 vol.) and toluene (5 vols.), and it has a lower distribution than cyanidin in a 5% solution of picric acid in a mixture of amyl ethyl ether (1 vol.) and anole (4 vols.). Petunidin is best characterised by its behaviour on extraction from an aqueous acid solution by the latter reagent (G. M. and R. Robinson, Biochem. J. 1931, 25, 1693). This test has served to establish the circumstance that petunidin is a homogeneous anthocyanidin, the criteria previously available having been insufficient to differentiate petunidin from a mixture of delphinidin and malvidin.

Petunidin is hydrolysed by hot, concentrated potassium hydroxide to phloroglucinol and a methyl ester of gallic acid. Demethylation with hydriodic acid in the presence of phenol leads to the conclusion that petunidin is a monomethyl ether of delphinidin (Willstätter and Burdick, Annalen, 1916, 412, 217), and G. M. and R. Robinson (*I.e.*) have shown that petunidin chloride is, in fact, identical with the 3'-O-methyl delphinidin chloride (I), which had been synthesised previously (Bradley, Robinson, and Schwarzenfcah, J.G.S. 1930, 793).

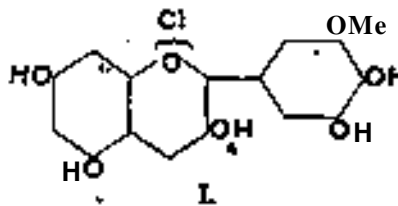

It is very probable that petunidin occurs naturally in the form of other glucosides than petunin. The 3-monoglucoside appears to be present in the colouring matter of the bilberry, the purplish berries of *Berberis darwinii* and those of *B. stenophylla*. *B. aquifolium* contains monoglycosides of delphinidin and malvidin accompanied possibly by those of petunidin; a glycoside of petunidin is present also in a variety of *Phlox drummondii*. The flowers of certain wine-red varieties of sweet peas owe their colour to a petunidin-3:5-dimonoside. A pentoseglycoside occurs in *Lilium lancifolium rubrum*, and diglycosides in *Tradescantia virginica*, *Rhododendron splendent*, *R. purple splendour*. *Lithospermum prostratum* contains a petunidin diglycoside in an almost pure form. The anthocyanins of *Lavatera trimestris rosea spkndens* also are based on petunidin (G. M. and R. Robinson, Biochem. J. 1931, 25, 1693; 1932; 26, 1647).

W. B.

PETUNIN is the name assigned by Willstätter and Burdick (Annalen, 1916, 412, 217), to a well-crystallised, homogeneous anthocyanin isolated by them from the petals of the petunia,

" Karlsruhe Rathaus." The velvety violet-blue petals were extracted with glacial acetic acid, and the dissolved anthocyanin was precipitated by adding ether to the bluish-red solution. It was an advantage to work up the extracts as quickly as possible, otherwise considerable loss of anthocyanin occurred. The precipitate crystallised readily from 0.5 to 1% hydrochloric acid, and further crystallisation from warm 1.5% acid gave petunin chloride in the form of the dihydrate,  $C_{28}H_{33}O_{17}Cl \cdot 2H_2O$ . The salt, which is obtained in the form of long, rectangular tables, having a coppery lustre, and appearing violet by transmitted light, sinters at  $165^\circ$ , and then melts at about  $178^\circ$ . The water of crystallisation and about one half of the chlorine are lost when the dihydrate is dried in a desiccator.

Petunin is sparingly soluble in cold, dilute hydrochloric acid. At 20 V 0 c.c. of acid of the concentrations indicated dissolve the weights of the chloride stated in brackets: 0.25% (0.67 g.); 0.5% (0.45 g.); 3% (CM\* g.). At the same temperature, 100 c.c. of 7% sulphuric acid dissolve 0.075 g. of the chloride.

In contact with water the chloride is easily hydrolysed with the formation of violet flocks of a compound which is probably a basic salt. In sufficient water a clear red-violet solution is obtained; acid solutions are redder in colour. The pseudo-base is formed slowly in cold dilute solutions, and more rapidly on heating. Solutions of petunin in dilute mineral acids are bluish-red, somewhat redder than acid solutions of delphinin, but markedly bluer than those of malvin. The same relationship between the colours of the three anthocyanins holds also for solutions in methyl-alcoholic hydrogen chloride. Petunin is easily soluble in ethyl alcohol, and very easily in methyl alcohol. It is completely extracted from solutions in amyl alcohol by shaking with dilute aqueous mineral acids; this is the normal behaviour of a diglucoside.

Ferric chloride imparts a violet colour to solutions of petunin in methyl alcohol; the effect is less marked in either water or ethyl alcohol. Sodium carbonate added to an acid solution changes the colour to violet, and this subsequently becomes blue. Neutral solutions give a greenish-blue with the alkali because of their content of pseudo-base, which in the pure condition dissolves in sodium carbonate solutions with a yellow colour.

Petunin does not form a sparingly soluble picrate; on hydrolysis by short boiling with 20% hydrochloric acid, it yields petunidin (?v.) (1 mol.) and glucose (2 mol.).

Bell and Robinson (J.C.S. 1934, 1604) have synthesised a number of petunidin glucosides and, while no direct comparison of synthetic and natural pigments was possible, it appeared probable that petunin would prove to be identical with petunidin-3:5-diglucoside (I).

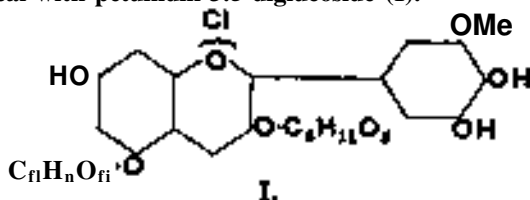

VOL. IX.—2\*

Other saccharides of petunidin are referred to in the article PETUNIDIN.

W. B.

**PETZITE.** A silver-gold telluride, approximately  $Ag_3AuTe_2$ , averaging about Ag 42, Au 25, Te 33%. It occurs massive, granular to compact, and has not been observed in good crystal form. The mineral is slightly sectile to brittle, and has a subconchoidal fracture;  $p$  8-7-9-0, hardness 2½-3. Colour, steel or iron-grey to iron-black, often tarnishing; lustre metallic. It is a minor ore-mineral of gold, notably in Western Australia at Kalgoorlie, and in the Ontario districts of Porcupine and Kirkland Lake.

D. W.

pH.

#### pH VALUES: THEIR SIGNIFICANCE.

The symbol pH was introduced by Sørensen to denote, as he then thought,  $-\log_{10}[H^+]$  in which  $[H^+]$  represents the concentration of hydrogen ions; it was assumed that ion concentrations could be determined with the aid of the conductance ratio,  $a = AdA_0$ , as required by the classical ionisation theory of Arrhenius. The introduction of the activity theory of electrolytes by G. N. Lewis, and particularly the theoretical support afforded by the theory of Debye and Hückel (1923) have made it exceedingly doubtful whether concentrations of ions can be so computed. Instead, *mean ionic activities* may be calculated from electromotive-force measurements, and the symbol, pH, accordingly receives a new significance, viz.,  $pH = -\log_{10} a_{H^+}$ , but as  $a_{H^+}$ , the activity of the hydrogen ion, cannot be determined,  $a_{H^+}$  is assumed to be equal to  $a_{\pm}$ , i.e., the mean ionic activity of the hydrogen ion and of the anion with which it is associated. Thus, if we consider the ionisation of hydrochloric acid as being complete, then  $HCl \rightleftharpoons H^+ + Cl^-$ ,  $0_{\pm} = (0_{H^+} \cdot 0_{Cl^-})^{1/2}$  from which it will be seen that  $a_{\pm}$  depends not only on  $a_{H^+}$  but on  $0_{Cl^-}$ . If another acid, HX, were taken then  $0_{\pm} = (a_{H^+} \cdot X_{aq})^{1/2}$  so that  $a_{\pm}$  would depend on  $0_{X^-}$ . On the basis of this theory it is not possible therefore to restrict pH to the activity of hydrogen ions alone and this constitutes a very serious defect.

Another difficulty lies in the fact that pH values are always calculated from the e.m.f.'s of cells with transport, between the two electrodes of which a saturated solution of potassium chloride is interposed with the object of eliminating the junction or diffusion potential which would be set up where the two electrode solutions would otherwise meet, e.g.,



It is to such cells that the activity theory has not been satisfactorily applied, despite the efforts of MacInnes and co-workers (J. Amer. Chem. Soc. 1935, 57, 1356; 1936, 58, 1970; 1937, 59, 503; Chem. Reviews, 1936, 18, 335) and Guggenheim and Schindler (J. Physical Chem. 1934, 38, 536). It is, however, from the e.m.f.'s of cells without transport, e.g.,



that mean ionic activities are computed, and



from which therefore  $\text{pH} = -\log_{10} a_{\pm}(\text{HX})$  should strictly speaking only be calculated.

A further confusion arises from the use in *cells with transport* of standard electrodes, e.g., the saturated, normal, and decinormal calomel electrodes, which have been standardised on the basis of the activity theory by means of *cells without transport*. The potentials of standard electrodes are referred to either one or other of two slightly different electrodes, the potentials of which are arbitrarily equated to zero. The first is the hydrogen electrode, supplied with hydrogen at a pressure of one atmosphere, in equilibrium with hydrogen ions at a supposed *S* concentration of 1 g.-ion per litre, i.e.,



potential— $\wedge_c$ , whilst the second is the hydrogen electrode with hydrogen at atmospheric pressure in equilibrium with *hydrochloric acid*, the *mean ionic activity of which is unity*, i.e.,  $\text{Pt-H}_2 \mid \text{HCl}, a_{\pm} = 1$ , potential =  $\text{tf}_1$ . The potential of a hydrogen electrode in terms of ion-concentrations is given by

$$E_c = \epsilon_c + 2.033(RT/F) \log_{10} [\text{H}']$$

so that when  $[\text{H}'] = 1$ ,  $\wedge_c = \epsilon_c = 0$  (arbitrarily) (the normal electrode potential of hydrogen) and it is this electrode which, for the purpose of standardising other electrodes, is arbitrarily equated to zero, whereas the potential of the hydrogen electrode in terms of ionic activities is

$$E_a = \epsilon_a + 2.303(RT/F) \log_{10} a_{\pm \text{H}_a}$$

whence by choosing a 'Solution of HCl in which  $a_{\pm \text{HCl}} \ll 1$ ,  $E_a = \epsilon_a$  (the standard electrode potential) and therefore the potential of the second standard,  $\wedge_0 = \epsilon_a = 0$  (arbitrarily). To standardise an electrode, e.g., the decinormal calomel, against the arbitrary hydrogen standard,  $J_c = \epsilon_c = 0$ , the e.m.f. of the cell:

$\text{Hg} \mid \text{Hg}_a \text{Cl}_2, 0.1\text{N-KCl} \mid \text{Satd. KCl} \mid \text{HCl}(c) \mid \text{H}_a\text{-Pt}$  must be measured, whence

$$\begin{aligned} \text{E.m.f.} &= E_{\text{H}_a\text{-Pt}} - E_{\text{Hg}} \\ &= E_{\text{H}_a\text{-Pt}} - \epsilon_c - 2.303(RT/F) \log_{10} [\text{H}'] \end{aligned}$$

where  $[\text{H}'] = ac = (A_c \lambda_{A_0})xc$ .

The potentials thus obtained are:

Decinormal calomel: 0.3380 V. at 18°c., 0.3371 v. at 25°c.

Normal calomel: 0.2863 v. at 18°c, 0.2846 v. at 25°c.

The potentials of standard electrodes as expressed in terms of the activity theory cannot be found by direct measurement, but are, instead, ascertained by graphical extrapolation of the e.m.f. of the cell  $\text{Ag} \mid \text{AgCl}, \text{HCl}(c) \mid \text{H}_a\text{-Pt}$  in which varying concentrations of hydrochloric acid are employed with respect to the e.m.f. of the *cell without transport*:

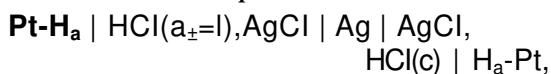

the extrapolation being rendered possible by assuming that when  $c=0$  the *mean ionic activity coefficient* becomes unity; in other words that at

infinite dilution not only is ionisation complete but the individual ions obey the perfect-gas laws. The extrapolated e.m.f. of the cell



is  $0.2225 \pm 0.0001$  v. at 25° (Prentiss and Scatchard, Chem. Reviews, 1933, 13, 139) and as the potential of  $\text{Pt-H}_2 \mid \text{HCl}(a_{\pm} = 1)$  is arbitrarily assumed to be zero, it follows that the potential of the electrode

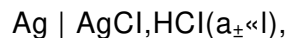

is  $+0.2225$  v. From this value, the potential of the standard electrode,



is calculated, viz.,  $+0.2882$  v. at 25°.

Randall and Yonng (J. Amer. Chem. Soc. 1928, 50, 989) found that at 25° the e.m.f. of the cell  $\text{Hg} \mid \text{Hg}_a \text{Cl}_2, \text{HCl}(c), \text{AgCl} \mid \text{Ag}$  remains at  $0.0546$  v. irrespective of the concentration,  $c$ , and they therefore concluded that both electrodes were in equilibrium with hydrochloric acid of which  $a_{\pm} = 1$ . Taking  $0.2225$  v. as the potential of the right-hand electrode, it follows that the potential of the left-hand electrode,  $\text{Hg} \mid \text{Hg}_a \text{Cl}_2, \text{HCl}(a_{\pm} = 1)$  must be  $+0.2681$  v. Knowing the mean ionic activity coefficients of KCl in 0.1N. and N. solutions and the foregoing potential, it can be shown by calculation that at 25° the potential of the decinormal calomel electrode is  $+0.3338$  v. and that of the normal calomel electrode is  $+0.2801$  v. When these potentials are compared with those found directly by using cells with transport it is found that the potential of the decinormal electrode is  $0.0033$  v. lower and the normal electrode  $0.0045$  v. lower.

Guggenheim and Schindler have attempted to apply the activity theory to *cells with transport*, but, instead of assuming that the junction potential between the two electrode solutions is completely eliminated by the interposition of a saturated solution of potassium chloride, they prefer to employ the Bjerrum method of using successively 3.5N-KCl and 1.75N-KCl as junction liquids in any given cell and regarding the *junction error introduced by the 3-SN-KCl to be equal to the difference between the e.m.f.'s of the two cells having the different junction liquids*. They measured at 25° the e.m.f.'s of cells of the type:

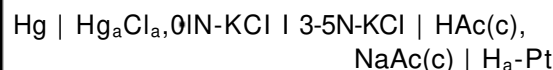

and by assuming (i) the correctness of Harned and Ehlers' value of the dissociation constant of acetic acid, viz.,  $1.75 \times 10^{-6}$  at 25° (*ibid.* 1932, 54, 1350; 1933, 55, 652), which was determined by means of *cells without transport*, and (ii) certain probable activity co-efficients, they deduced a value of  $+0.3337$  v. as being that of the decinormal calomel electrode, when incorporated in *cell with transport*. Whilst such a value is in good accord with  $+0.3338$  v., based purely on the activity theory, it does cause serious differences in the precise values of pH normally calculated from the e.m.f. of hydrogen-decinormal

calomel cells. Thus the adoption of Guggenheim and Schindler's value of 0.3337 leads to pH values that are 0.005 pH unit higher than those found by using Soreuson's value of 0.3376 v. as the potential of the decinormal calomel electrode.

This confusion is intensified by the fact that originally the electro metric methods of determining pH values [v. HYDHOQEN ION DETERMINATION, Vol. VI, 3386) were based on potentials ascribed to the standard electrodes on the basis of the Arrhenius theory, whereas more recently there has been a tendency on the part of workers to be inconsistent and to assign values to the standard electrodes indiscriminately, for they have not troubled to ascertain how these values have been derived. Furthermore, it should be remembered that the calibration of most of the buffer solutions used in colorimetric methods of determining pH values was carried out by means of the hydrogen electrode in conjunction with standard electrodes, generally either the decinormal\* or normal calomel, to which potentials were assigned on the basis of the classical theory of Arrhenius. It would be better if in all determinations of pH values in which cells with transport are employed workers would, until the mechanism and e.m.f.'s of such cells are more fully understood, use potentials of the standard electrodes that have been deduced from the classical theory.

Significance of pH.—The effect of the modern theory of electrolytes has been to obscure somewhat the meaning of pH, for although the Arrhenius theory provides a clearer picture of ions in terms of concentrations, the activity theory gives a more accurate idea of what might be regarded as the "effective" concentrations of ions. But, despite the inadequacies of the Arrhenius theory, pH may still be regarded as being approximately the negative power of the hydrogen ion concentration when raised to the base of 10. Moreover, whatever may be their precise significance, pH values do give an excellent method of representing varying degrees of acidity and alkalinity, and it is in this respect that their measurement and control have been so valuable in chemical and technical processes.

pH Scale.—In any aqueous solution the ionisation of water occurs, thus,

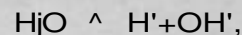

and the equilibrium thereby established is repressed towards the left by the introduction into the solution of either hydrogen ions or hydroxyl ions. At a constant temperature the product,  $[H^+][OH^-] = i_w$ , the so-called *ionic product of water*. In absolutely pure water  $[H^+] = [OH^-]$ , whence at true neutrality  $A_w = [H^+]$  and therefore  $[H^+] = \sqrt{i_w}$ , or in terms of pH,

$$- \log_{10} [H^+] = \frac{1}{2} (- \log_{10} K_w)$$

i.e.,  $pH = \frac{1}{2} pK_w$ , where  $pK_w$  is the negative exponent of  $K_w$  to the base 10. Table I gives the values of  $\sqrt{K_w}$  and the pH of true neutrality at various temperatures.

TABLE I.

Temperature, °C.	$\sqrt{K_w}$	pH at neutrality.
0	11.94	7.47
16	14.20	7.10
18	14.13	7.00
20	14.07	7.03
22	14.00	7.00
25	13.90	6.95
30	13.73	6.86
37	13.51	6.75
40	13.42	(6.71)
100	12.00	6.12

It will be noticed that an increase in temperature brings about a gradual increase in  $K_w$  with the result that the pH value corresponding with true neutrality progressively diminishes from 7.47 at 0° to 6.12 at 100°, the pH at ordinary temperature being approximately 7.00.

In Table II it will be seen that decreasing degrees of acidity are represented by pH values ranging from 0 to 7, whereas the pH range from 7 to 14 represents increasing alkalinity. The

TABLE II.—THE pH SCALE.

[H <sup>+</sup> ]		pH.	[OH <sup>-</sup> ].	pOH.	
1	= 10 <sup>0</sup>	0	10 <sup>14</sup> *	14	Logarithmic decrease  in '  Acidity  I  *—Neutrality  I  Logarithmic increase  in  *  Alkalinity.
0.1	= 10 <sup>-1</sup>	1	10 <sup>13</sup>	13	
0.01	= 10 <sup>-2</sup>	2	10 <sup>12</sup>	12	
0.001	= 10 <sup>-3</sup>	3	10 <sup>11</sup>	11	
0.0001	= 10 <sup>-4</sup>	4	10 <sup>10</sup>	10	
0.00001	= 10 <sup>-5</sup>	5	10 <sup>9</sup>	9	
0.000001	= 10 <sup>-6</sup>	6	10 <sup>8</sup>	8	
0.0000001	= 10 <sup>-7</sup>	7	10 <sup>7</sup>	7	
0.00000001	= 10 <sup>-8</sup>	8	10 <sup>6</sup>	6	
0.000000001	= 10 <sup>-9</sup>	9	10 <sup>5</sup>	5	
0.0000000001	= 10 <sup>-10</sup>	10	10 <sup>4</sup>	4	
0.00000000001	= 10 <sup>-11</sup>	11	10 <sup>3</sup>	3	
0.000000000001	= 10 <sup>-12</sup>	12	10 <sup>2</sup>	2	
0.0000000000001	= 10 <sup>-13</sup>	13	10 <sup>1</sup>	1	
0.00000000000001	= 10 <sup>-14</sup>	14	1	0	

transition from acidity at pH 7 to alkalinity will be understood from the fact that

$$[H^+][OH^-] = K_w = 10^{-14};$$

or in terms of negative indices,

$$pH + pOH = pK_w = 14.$$

Substituting 8 for pH in the foregoing equation, we find that pOH is 6, i.e.  $[OH^-] = 10^{-6}$  whereas the  $[H^+] = 10^{-8}$ . Hence pH 8 corresponds with alkalinity for it indicates a greater concentration of  $OH^-$  ions than of  $H^+$  ions. Although one is apt to regard the pH scale as being divided into equal unit divisions, it should be remembered that the pH scale is actually logarithmic and that each successive pH unit represents a diminution in hydrogen-ion concentration such that the concentration of hydrogen ions is equal to one-tenth of that indicated by the im-

mediately lower pH value. Table III gives the pH values at 18° of various solutions.

TABLE III.

Electrolyte.	pH.
N-HCl	0-10
0.1N-HCl	1-07
0.1K-H <sub>2</sub> SO <sub>4</sub>	1-23
0.01N-HCl	2.0a
0.001N-HCl	3.01
0.1N-CH <sub>3</sub> COOH	2.87
0.1N-NH <sub>4</sub> OH	11-27
0.001N-NaOH	11-13
0.01N-NaOH	12-12
0.1N-NaOH	13.07
0.1N-NaOH	14.05

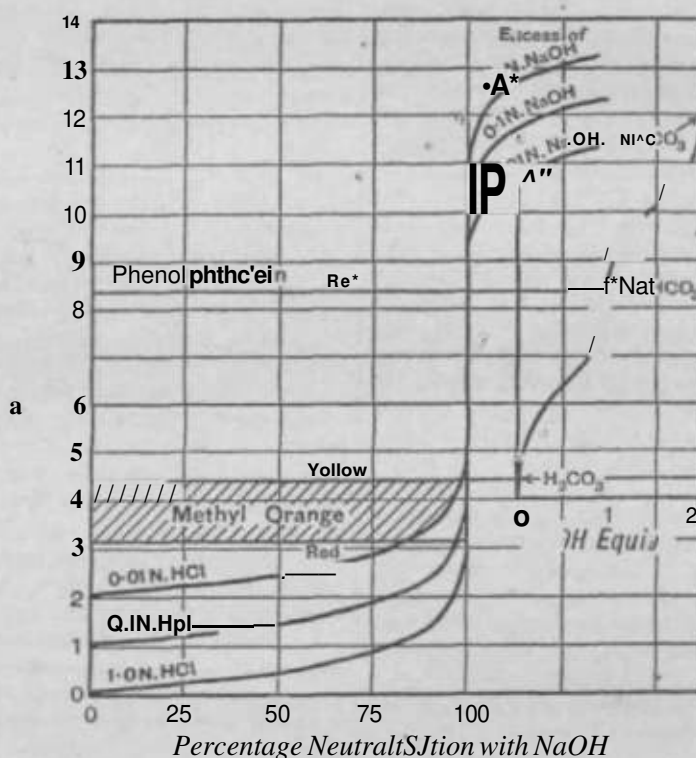
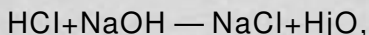

Fig. 1.

Variation in pH during the Neutralisation of Acids and Bases.—1. *Strong Acid Neutralised with a Strong Base, e.g., HCl with NaOH.*—As HCl is neutralised with NaOH,



the un-neutralised HCl is largely ionised,  $HCl \rightleftharpoons H^+ + Cl^-$  and so is the NaCl that is formed,  $NaCl \rightleftharpoons Na^+ + Cl^-$ , thereby producing  $Cl^-$  ions which are common to both these dissociations. It might be expected that the increasing  $Cl^-$  ion concentration set up as the neutralisation proceeds would, according to the Law of Mass Action, materially repress the ionisation of the yet un-neutralised HCl and so reduce the concentration of hydrogen ions to an extent greater than could be attributed to the gradual fall in concentration of the acid. This

is not the case, for the concentration of  $Cl^-$  ions originating from the salt formed has but little effect. This failure of the Arrhenius theory, in its inability to provide a means of calculating ion concentrations which are in harmony with the requirements of the Mass Law, has cast grave doubts on its validity when applied to ionisation considered in terms of the Arrhenius theory. In carbon-dioxide free solutions Fig. 1 shows the variation in pH when 100 c.c. of (a) N-HCl is titrated with 0.1N-NaOH, (b) 0.01N-HCl is titrated with 0.1N-NaOH, (c) 0.001N-HCl is titrated with 0.1N-NaOH. (The inset diagram shows the pH changes which occur during the neutralisation with alkali of any dissolved carbon dioxide.) The pH values set up at 99% and 99.9% neutralisation can be calculated approximately from the concentrations of the HCl then un-neutralised, the degree of

ionisation being negligible. Such values are given in Table IV.

TABLE IV.

Concentrations of reactants.	N.		0.1N.		0.01N.	
	$C_{HCl}$	pH.	$C_{HCl}$	$a$	$C_{HCl}$	pH.
99.0	502 $\times 10^{-3}$	2.30	5.02 $\times 10^{-4}$	3.30	5.02 $\times 10^{-5}$	4.30
99.9	500 $\times 10^{-4}$	3.30	500 $\times 10^{-5}$	4.30	500 $\times 10^{-6}$	5.30

When carbon dioxide is present in the solutions, as it invariably is, the inset neutralisation curve of  $H_2CO_3$  shows that its neutralisation begins at pH 4.4, whilst Table IV reveals that in N. solution HCl is 99.9% neutralised at pH 3.3 and in 0.1N. solution at pH 4.3, and that in 0.01N. solution it is 99% neutralised at pH 4.3. It happens that Methyl Orange changes from red to yellow within the pH range 3.1-4.4, although when undergoing rapid change in colour such as occurs in the course of a neutralisation of a strong acid with a strong base this indicator appears to most eyes to undergo the most perceptible change at pH 4.3, when it has acquired an orange colour (pH 4.3 is therefore described as the pT or "titration exponent" of Methyl Orange). It will thus be seen that by using Methyl Orange it is possible to titrate HCl in N. and 0.1N. solutions with a respective accuracy of 0.01% and 0.1% and in 0.01N. solution to within 1%, though in the last case, as Fig. 1 shows, the colour change of the indicator will extend over the last 15% of the neutralisation.

To titrate to a definite pH value, such as is necessary in the foregoing neutralisations, use may be made of the so-called "screened," "masked," or "achromatic" indicators. These consist of the ordinary indicator solutions which contain other coloured substances (dyes or other indicators) in such concentrations that the colours and intensities they impart serve as complementary colours to those produced by the indicators themselves at any desired pH values. Table V gives examples of indicators which yield "masked" colours—theoretically, they should be colourless, but in actual practice are either grey or yellow—on the attainment of pH 4.3.

TABLE V.

Indicator mixture.	Colour change.		
	Below pH 4.3.	At pH 4.3.	Above pH 4.3.
0.02% Methyl Orange + 0.1% Bromocresol Green.	Orange.	Yellow.	Green.
0.1% Methyl Orange + 0.1% Aniline Blue.	Violet.	Grey.	Green.
0.2% Ethyl Orange + 0.1% Methyl Green.	Blue.	Grey.	Green.
0.5% Alizarin Red + 0.063% Methylene Blue.	Green.	Grey.	White.

In the reverse titration, viz., that of a strong base with a strong acid, the neutralisation will take place at high pH values. If carbon dioxide were absent the end-point would be indicated by a well-defined inflexion, the location of which could be detected by the disappearance of the red colour of the phenolphthalein at pH 8.3, but as any carbon dioxide in the alkali will be present as sodium carbonate the HCl will react with it between pH 12.2 and 8.2, thus



with the consequence that the HCl titre to phenolphthalein will include both the free alkali and the sodium carbonate. The use of Methyl Orange will involve the still further replacement reaction:

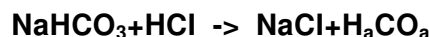

for it takes place between pH 8.4 and 4.4.

2. *Weak Acid Neutralised with a Strong Base.*—For practical purposes, the Law of Mass Action, when the ion concentrations are interpreted in terms of the Arrhenius theory by means of  $a = A_c / A_0$ , applies to the ionisation of weak acids (a) at different dilutions  $V$  (in the form of the so-called Ostwald Dilution Law,  $K = a^2 / [(1-a)V]$ ), and (b) in the presence of salts having a common ion. In actual fact, precise measurements of conductivity and e.m.f. show that the dissociation constant,  $K$ , diminishes slightly as the concentration is reduced. This may be seen from Table VI, which is based on the conductometric data for acetic acid of MacInnes and Shedlovsky (J. Amer. Chem. Soc. 1932, 54, 1429) and on the hydrogen electrode data of A. A. Moss (Ph.D. Thesis, London, 1936) for mandelic acid.

TABLE VI.

Acetic acid (25°c).		
Concn.	K.	pK.
0.05230	1.811 $\times 10^{-5}$	4.74
0.005912	1.798 $\times 10^{-5}$	4.745
0.001028	1.781 $\times 10^{-5}$	4.75
0.000153	1.767 $\times 10^{-5}$	4.75
0.0000280	1.760 $\times 10^{-5}$	4.75
Mandelic acid (18°c).		
Concn.	A'	pK.
0.09925	1.65 $\times 10^{-4}$	3.33
0.009925	4.17 $\times 10^{-5}$	3.38
0.0009925	3.79 $\times 10^{-5}$	3.42

A similar diminution in the dissociation constants of dibasic and tribasic acids with dilution has been observed, as may be seen from R. Gane and C. K. Ingold's data for malonic acid obtained with the hydrogen electrode at 25° (Table VII) (J.C.S. 1931, 2153).

TABLE VII.—APPARENT DISSOCIATION CONSTANTS OF MALONIC ACID AT 25°.

Concn.	005 M.	002 H.	001 M.	0004 M.	000125 M.
$K_{a1}$	1.77 x10 <sup>-3</sup>	1.58 x10 <sup>-3</sup>	1.54 x10 <sup>-3</sup>	1.51 x10 <sup>-3</sup>	1.49 x10 <sup>-3</sup>
$pK_{a1}$	2.75	2.80	2.81	2.82	2.82
$K_{a2}$	4.12 x10 <sup>-4</sup>	2.55 x10 <sup>-4</sup>	2.40 x10 <sup>-4</sup>	2.11 x10 <sup>-4</sup>	2.12 x10 <sup>-4</sup>
$pK_{a2}$	5.39	5.59	5.62	5.68	5.67

When the dissociation constants are expressed in the form of  $j)K_a$  (i.e.,  $-\log_{10}K_a$ ), it will be observed that the deviations almost disappear; in fact, the  $\log_{10}K_a$  values are so nearly constant that the deviations will not materially affect the following considerations.

Throughout the neutralisation of a weak acid, HA, with a strong base, e.g., NaOH;

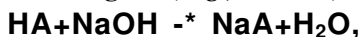

the hydrogen-ion concentration will depend on the extent to which the ionisation of the un-neutralised acid,  $HA \rightleftharpoons H^+ + A^-$ , is repressed by the common anions,  $A^-$ , originating from the salt, NaA, that is progressively being formed.

$$\text{Hence } K_a = \frac{[H^+][A^-]_{\text{ex acid}} + [A^-]_{\text{ex salt}}}{[HA]}$$

therefore

$$-\log_{10}[H^+] = -\log_{10} \frac{([A^-]_{\text{ex acid}} + [A^-]_{\text{ex salt}})}{[HA]}$$

$$\text{or } p\bar{H} = pK_a + \log_{10} \frac{([A^-]_{\text{ex acid}} + [A^-]_{\text{ex salt}})}{[HA]}$$

As  $[H^+] = [A^-]_{\text{ex acid}}$ ,

therefore  $[HA] = C_{\text{un-neutralised}} [H^+]$

and assuming that the salt, NaA, formed is completely ionised, it follows that

$$[A^-]_{\text{ex salt}} = C_{\text{NaA}} = C_{\text{HA neutralised}}$$

whence

$$p\bar{H} = pK_a + \log_{10} \frac{([H^+] + C_{\text{HA neutralised}})}{C_{\text{HA un-neutralised}} [H^+]}$$

In the case of weak acids having  $K=10^{-5}$  or less,  $[H^+]$  is negligibly small when compared with either  $C_{\text{HA neutralised}}$  or  $C_{\text{HA un-neutralised}}$  so that the equation may then be simplified to

$$p\bar{H} = pT_a + \log_{10} \frac{C_{\text{HA neutralised}}}{C_{\text{HA un-neutralised}}}$$

and if  $x$  be the percentage neutralisation, then

$$p\bar{H} = pT_a + \log_{10} \left\{ \frac{x}{100-x} \right\}$$

Somewhat higher pH values than those calculated from this equation are set up, depending on the concentration of acid used in the early stages of the neutralisation of weak acids of which  $K$  is  $10^{-5}$ – $10^{-6}$ , owing to the fact that then the concentration of salt NaA, has not become sufficiently large to repress the ionisation of HA to negligible dimensions. The unsimplified expression must then be used. In the case of very weak acids,  $A^-$  is about  $10^{-10}$  and

less, the pH values prevailing during the final portions of the titrations are lower than required by the equation. This is caused by the occurrence of some hydrolysis of the salt, NaA, formed, or more accurately by the equilibrium  $NaOH + HA \rightleftharpoons NaA + H_2O$ , or ionically:



Hence  $[HA] = [pH^-]$  and consequently

$pH =$

$$pK_a + \log_{10} \frac{C_{\text{HA neutralised}}}{C_{\text{HA un-neutralised}}}$$

The equation:  $pH = pT_a + \log_{10} \left\{ \frac{x}{100-x} \right\}$  gives what might be regarded as the fundamental relationship between pH and  $x$  throughout the neutralisation of a weak acid, from which the pH values in Table VIII, have been calculated.

TABLE VIII.

$x$	pH.	$\bar{p}$
0.1	ptfa-3.00	99.9
1.0	$pK_a - 2.00$	99.0
5.0	$pK_a - 1.28$	95.0
10.0	piTa-0.95	90.0
20.0	pXo-0.60	80.0
30.0	pirfi-0.37	70.0
40.0	ptfa-0.17	60.0
50.0	$pK_a$	50.0
60.0	$pX_{fi} + 0.17$	40.0
70.0	piTa+0.37	30.0
80.0	pXa+0.60	20.0
90.0	pJTa+0.95	10.0
95.0	$pK_a + 1.28$	5.0
99.0	$pK_a + 2.00$	1.0
99.9	$pK_a + 3.00$	0.1

The pH value at 50% neutralisation is seen to be equal to the  $pK_a$  value. For acetic acid  $JT_a = 1.8 \times 10^{-5}$  and therefore  $pJT_a = 4.74$ , i.e.,  $pH = 4.74$ . The shape of the weak acid curve is shown in Fig. 2 and the effect of the  $-pK_a$  of a weak acid is merely to raise or lower neutralisation curve with respect to the pH scale. Table VIII shows that between 10% and 90% neutralisation the pH changes from  $-pX - 0.95$  to  $piT + 0.95$ , i.e., only an increase of 1.9 pH units although 80% of the neutralisation occurs. During the first 10% and the last 10%, however, the pH changes are considerable. Thus from 0.1 to 10% the pH changes from  $piT_a - 3.00$  to  $pJT_a - 0.95$ , an increase of 2.05 pH units, and a similar increase occurs from 90 to 99.9%; whereas from 1 to 10% the pH changes from  $plir_a - 3.00$  to  $pK_a - 0.95$ , an increase of 2.05 pH units, and a similar increase occurs from 90 to 99.9%; whereas from 1 to 10% and 90 to 99% the increases are each equal to 1.05 pH unit. For titrimetric work it is sufficient to consider as the pH range within which the neutralisation of a weak acid takes place as beginning with the pH value at 1% neutralisation, viz.,  $ptf - 2.00$  and ending at the pH value at 99% neutralisation, viz.,  $pK_a + 2.00$ . To sum up: a weak acid, in effect, begins to be neutralised at  $pH = pJT_a - 2$ , is half-neutralised at  $pH = pJT_a$  and is completely

neutralised at  $pH = pK_a + 2$ ; a total pH range of 4 pU.

Conversely, a weak acid, HA, is progressively liberated from combination as the salt of a strong base, NaA, by a strong acid, e.g., HCl, thus:

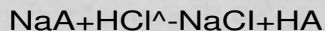

between  $pH = pK_a + 2$  and  $pH = pK_a - 2$ , and the change in pH is that given in Table VI, y being the percentage of HA replaced by the strong acid.

The range from  $x=10$  to  $x=90$  is buffered to the action of alkali, whereas the range  $y=10$  to  $y=90$  is buffered with respect to the action of strong acids. In other words, within this range the system is such that it resists the action of acids in setting up low pH values and

the action of alkalis in setting up high pH values. The maximum buffer-action to either acids or bases is when  $x=y=50\%$ .

It might be questioned why the pH value at 99% neutralisation is chosen as indicating the effective end of neutralisation, so much so that it is advisable to select an indicator, the virage, of which is just above  $pH = pK_a + 2$ . Unless an acid is very weak the slight hydrolysis of the salt formed does not affect the pH until the theoretical quantity of alkali for complete neutralisation is added, owing to the extremely low concentration of weak acid that is necessary to repress hydrolysis. The pH value at the stoichiometrical end-point, by putting  $x=100$  in the fundamental equation would appear to be infinity. Actually, at this point the pH is set up directly by the hydrolysis of NaA.

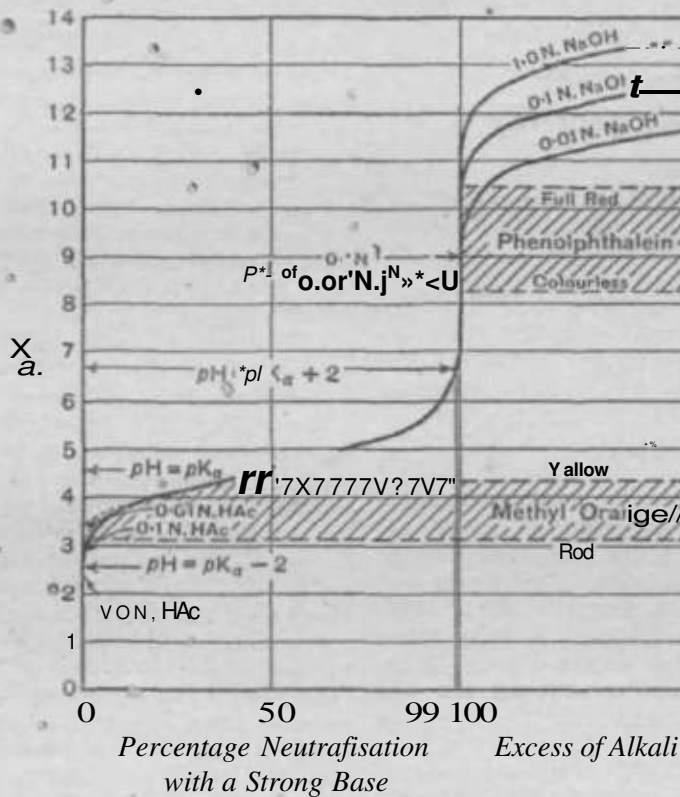

FIG. 2.

pH Value at  $x=100$ .—Consider the hydrolytic equilibrium:



If it is assumed that NaA and NaOH are completely ionised and that, in comparison, the ionisation of HA is negligible, it follows that



for which

$$K_b = \frac{[OH^-][HA]}{[A^-][H_2O]}$$

i.e.,  $K_b[H_2O] = K_x (1,000/18)$

$$= K_b = \frac{[OH^-][HA]}{[A^-]}$$

Multiplication by  $[H^+]/[H^+]$  gives

$$K_b = \frac{[H^+][OH^-] \times [HA]}{[H^+][A^-]} = \frac{K_w}{K_a}$$

Also  $[OH^-][H^+] = K_w$  and  $[H^+][A^-] = K_a \frac{[HA]}{[A^-]}$

$$K_b = \frac{K_w}{K_a} = \frac{[OH^-]^2 [A^-]}{[A^-]^2 [H^+]^2}$$

and therefore

$$[H^+] = \sqrt{\frac{K_a K_w}{[A^-]}}$$

If  $c$  = concentration of NaA, then  $[A^-] = c - [OH^-]$ , but if  $[OH^-]$  is negligibly small compared with  $c$ , then  $[H^+] = \sqrt{\frac{K_a K_w}{c}}$ , whence it follows that  $pH = \frac{1}{2}(pK_a + pK_w + \log_{10} c)$ .

As an example, reference may be made to the neutralisation of acetic acid, for which  $pK_a = 4.74$  and therefore the pH at 99% neutralisation is 6.74, whereas when  $c = 0.1M$ , the above equation gives  $pH = \frac{1}{2}(14 - 4.74 + \log_{10} 0.1) = 8.87$  and when  $c = 0.01N$ , the  $pH = 8.37$ , from which it will be seen that during the neutralisation of the last 1% of HA a relatively large increase in pH occurs, which in the case of a weaker acid would necessitate the use of an indicator, the colour change of which would take place at high pH values that are such as would lead to substantial errors in titration.



In these calculations, use should be made of the "apparent" dissociation constant at the desired concentrations. But as the constants generally recorded are the so-called "thermodynamic" constants, denoted by  $k_a$ , consideration must be given to the effect that they might have on the pH values during neutralisation.

As  $k_a = \frac{[A^-][H^+]}{[HA]}$  and as an e.m.f. determination with the hydrogen electrode is supposed to give a measure of  $\langle H^+ \rangle$ , activity of the hydrogen ion, it appears that the "apparent" dissociation constant.

$$K_a = a_{H^+} \frac{[A^-]}{[HA]}$$

But as  $\langle H^+ \rangle = \frac{[H^+]}{f_{H^+}}$ , denoting the activity coefficient, it follows that

$$k_a = K_a \times (f_{A^-}/f_{HA})$$

i.e.,  $pK_a = p k_a + \log_{10} (f_{A^-}/f_{HA})$

Combination of this equation with

$$pH = pK_a + \log_{10} \left( \frac{[A^-]}{[HA]} \right)$$

leads to

$$pH = p k_a + \log_{10} \left( \frac{[A^-]}{[HA]} \right) + \log_{10} (f_{A^-}/f_{HA}),$$

whence by assuming that  $f_{HA} = 1$ ,

$$pH = p k_a + \log_{10} \left( \frac{[A^-]}{[HA]} \right) + \log_{10} f_{A^-}$$

Unfortunately, the activity coefficient of a single ion cannot be experimentally determined, but in extremely dilute solutions it may be computed with the aid of the Debye-Huckel equation:

$$-\log_{10} f = z^2 A \sqrt{\mu}$$

where  $z$  = valency of the ion, and  $A$  for water = 0.4863 at 0°, 0.4992 at 18°, 0.5066 at 26°, and 0.5186 at 38°C., and  $p$  is the mean ionic strength. This concept was introduced by Lewis and Randall (J. Amer. Chem. Soc. 1921, 48, 1112) in order to refer the mean ionic activity of an electrolyte to the total electrical state of the solution. It takes into account all the ions present in the solution such that

$f_i = b f_i^z$  (concentration of each ion)

$X$  (square of its valency).

(For fuller details of the calculation of  $f_i$  for weak acids undergoing neutralisation the reader is referred to H. T. S. Britton, "Hydrogen Ions," 3rd ed., Chapman and Hall, 1942, Vol. I, pp. 288-292.)

Indicators.—As far as the colour change of indicators is concerned, following Ostwald's suggestion, they generally may be regarded as weak acids,  $HIn$  (or weak bases  $InOH$ ) such that one colour may be considered as due to the undissociated acid (or base) and the other to the ionised form:

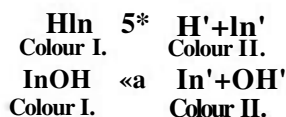

Owing to the weakness of  $HIn$ , the  $In^-$  ions are completely formed only when the acid has been neutralised with a strong base in the form

of a salt, ionising thus:  $NaIn \rightleftharpoons Na^+ + In^-$ . During neutralisation, which will be governed by

$$pH = pK_{HIn} + \log_{10} \left( \frac{[In^-]}{[HIn]} \right),$$

if the intensities of Colour I and Colour II which together make up the colours assumed by the indicator as it is progressively neutralised are proportional to  $[HIn]$  and  $[In^-]$ , respectively, then the above expression becomes

$$pH = pK_{HIn} + \log_{10} \frac{\text{Intensity of Colour II}}{\text{Intensity of Colour I}}$$

The human eye, unaided, is unable to detect the faint change in colour during the first 10% and the last 10% neutralisation of an indicator. It is between 10 and 90% neutralisation that the gradual change in colour (the *virage*) can be readily perceived and, as Table VIII shows, the *virage* takes place within the pH range:  $pH = pK_{HIn} - 0.95$  (at 10%) and  $pH = pK_{HIn} + 0.95$  (at 90%), which thus extends over 1.9 pH units. This is approximately the magnitude of the transition pH interval of the majority of indicators, excepting those of vegetable origin, e.g., litmus, for practical purposes, the range of an indicator which yields "acid" and "alkaline" colours to which the eye is not equally sensitive the pH range becomes somewhat less than 1.9 pH units." Thus for methyl orange,  $pK_{HIn} = 3.7$ , but its useful range is pH 3.0 to pH 4.6 owing to the eye being more sensitive to red than to yellow, thereby causing its initial pH to be 3.0 instead of pH 2.75.

The colorimetric determination of the pH value of a test solution may be made:

(a) By comparing the colour, produced by adding a suitable volume of indicator to the test solution to impart to it a pale but definite tint, with the colours of a series of standard buffer solutions which differ in pH value by 0.1 or 0.2 unit, each standard having the same concentration of indicator that was used in the test solution. The pH values of these buffer solutions should correspond with that of the pH range of the indicator. When necessary, compensation should be made for any colour possessed by the test solution. To avoid "salt errors" of the indicator the ionic strength of the test solution should be approximately equal to that of the standard buffer solutions. Another source of error is that which may be caused by the indicator itself in imparting to the test solution a concentration of hydrogen ions. With such unbuffered solutions, a method based on the principle of *isohydry* must be adopted (see H. T. S. Britton, *op. cit.*, Vol. I, pp. 371-374).

(b) By methods based on a knowledge of  $[HIn]$  and comparing the colour imparted to the test solution with the composite colours obtained when  $z\%$  of the indicator is in the  $In^-$  form and  $(100-z)\%$  is in the  $HIn$  form. When the colour produced in the test solution is identical when viewed through the same depth of solution as that through which the composite colour is observed, then  $pH = pK_{HIn} + \log_{10} \left\{ \frac{z}{100-z} \right\}$  (H. T. S. Britton, *op. cit.*, pp. 339-365).

The Neutralisation of Mixtures of Monobasic Acids.—If the  $pK_a$  values of two acids, say  $HX$  and  $HY$ , differ by 4 or more



unite, i.e.,  $PAHY \sim P \cdot HX^4$ , the neutralisation of the stronger acid, HX, will effectively end at at  $pH = pK_{HX} + 2$ , whereas the neutralisation of the weaker acid will begin at  $pH = pK_{HY} - 2$ , which pH value will be higher than, or the same as, the former pH value. Consequently, the termination of the neutralisation of the stronger acid, HX, will result in a sharp rise in pH which may be located by titrating, (y) to the colour assumed by an indicator corresponding to the (ill at the point of inflexion of the pH curve, or (E) to the change-point of an achromatic indicator adjusted to indicate this pH. Acetic acid,  $pK = 4.74$ , and boric acid,  $pK = 2.2$ ; institute such a mixture (see Fig. 3, for which the point of inflexion will be at pH 7.0), Fig. 3 shows the change in pH which occurs during the neutralisation with 0.1N-NaOH, of a solution of hydrochloric, acetic, and boric acids, each being 0.1y. Neither the first nor the third inflexion is sufficiently well-defined for the end-

points to be accurately determined by means of indicators. The addition of an excess of glycerol or mannitol lowers the whole of the boric acid section in such a way that its end-point is indicated by phenolphthalein, although as the broken line shows the inflexion marking the end of the neutralisation of acetic acid will thereby be obliterated.

The Neutralisation of Di- and Tri-basic Acids with Strong Bases.—As far as the neutralisation of polybasic acids is concerned they may be considered as mixtures in equivalent proportions of separate monobasic acids. They will undergo successive neutralisation in the order of their relative strengths. The strong add stage of ionisation will be neutralised first, to be followed by the weak acid stages in the order of their increasing  $pK_{E_t}$  values. The pH range required for the neutralisation of weak acid, viz.,  $pK_a - 2$  to  $pK_a + 2$ , applies, but if  $pK_{a1}, pK_{a2}, pK_{a3}$ ,  $pA_{oj}$  (referring to the first, second,

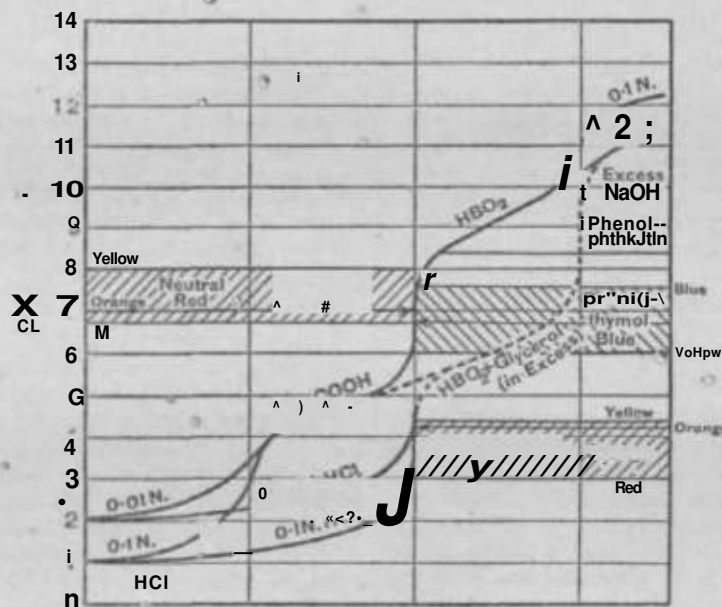

NaOH  
Fig. 3.

and third stages of ionisation, respectively) do not differ greatly from one another, the pH ranges corresponding to the different acid stages will overlap, with the result that the inflexions marking the end of each stage of neutralisation will become ill-defined or may be entirely absent. This will occur, as may be seen graphically by placing the neutralisation curves of two weak acids side by side, the dissociation constant of the first acid being 10-100 times that of the second acid. (Consider, e.g., the constants of Htric acid, Table IX, and the titration curve in Fig. 4.)

Table IX and Fig. 4 serve to illustrate the pH curves of di- and tri-basic acids. The magnitude of the inflexions, including the pH values at the equivalence points, will show whether they can be accurately located by means of indicators.

Reference should be made to the neutralisation of  $H_2S$ . As its  $pK_{a1}$  is 7.0 the neutralisation of

the first stage :  $H_2S + NaOH \rightarrow NaHS + H_2O$  will be complete at pH 9, for which thymolphthalein is a suitable indicator. But the  $pK_{a2}$  of  $H_2S$  is 14.9, from which it is seen that the neutralisation pH range is from pH 12.9 to pH 16.9. Such a high pH value as 16.9 cannot be reached even with the most concentrated solutions of alkali, which means that in solution,  $NaHS$  cannot be completely converted into  $Na_2S$ : thus in the presence of an excess of 0.1N-NaOH, pH 13.07, the neutralisation can proceed only to 2-3% of the second stage.

The Reaction between a Strong Acid and (i) a Weak Base, (ii) a Salt of a Strong Base and a Weak Acid.—(i) Fig. 5 shows the titration curve of Q-IN-HCl with  $NH_4OH$ . As the equation

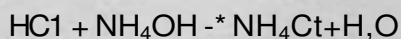

shows,  $NH_4Cl$  is formed, so that as soon as the HCl has been converted into this salt the pH set

TABLE IX.

Aoid.	$K_{a1}$ .	pffl,-	$X_{ar}$	$pK_{a2}$ .	Kay	P#ay
Sulphuric, $H_2SO_4$	Strong.	—	Strong.	—		
Oxalic, $H_2C_2O_4$		—		• 4.0		
Sulphurous, $H_2SO_3$	"	—	$5 \times 10^{-9}$	5.3		
Chromic, $H_2CrO_4$		—	$4.4 \times 10^{-7}$	6.4		
Carbonic, $H_2CO_3$	$3 \times 10^{-7}$	6.5	$6 \times 10^{-11}$	10.2		
Hydrosulphuric, $H_2S$	$9 \times 10^{-8}$	7.0	$1.2 \times 10^{-13}$	14.9		
Phosphoric, $H_3PO_4$	Strong.	—	$14 \times 10^{-7}$	6.9	$2.7 \times 10^{-12}$	11.6
Arsenic, $H_3AsO_4$	$5.6 \times 10^{-3}$	—	$1.7 \times 10^{-7}$	6.8	$3.0 \times 10^{-12}$	11.5
Citric, $H_3C_6H_8O_7$	$1 \times 10^{-8}$	—*J	$2.5 \times 10^{-6}$	4.6	$1.5 \times 10^{-4}$	5.8

up by the increasing excess of  $NH_4OH$  will be governed by the two ionizationfl :

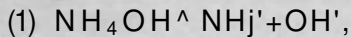

for which

$A^i = \frac{[NH_4^+][OH^-]}{[NH_4OH]}$  and



BO that

$pOH = pK_b + \log \left\{ \frac{[NH_4^+]}{[NH_4OH]} \right\}$ .

and because

$pH + pOH = 14$

it follows that

$pH = 14 - pK_b - \log \left\{ \frac{[NH_4^+]}{[NH_4OH]} \right\}$ .

The change in pH after the equivalence point reveals the presence of a buffer system which, as the foregoing equation shows, is produced by the varying ratio of  $[NH_4^+]$  and  $[NH_4OH]$ , i.e., of  $[NH_4Cl] : [NH_4OH]$ . The pH value on adding two equivalents of  $NH_4OH$  is given by  $pH = pK_b$ , for then  $[NH_4^+] = [NH_4OH]$ .

(ii) Two curves are given in Fig. 6 representing the pH values set up when an excess of  $Na_2CO_3$  is added to HCl. From the equation:

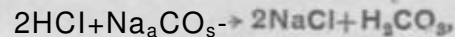

it is seen that  $H_2CO_3$  is progressively liberated, of which, at ordinary temperature, some will remain in solution, whereas on boiling the carbon dioxide can be driven off. The uppermost curve represents the pH values that will

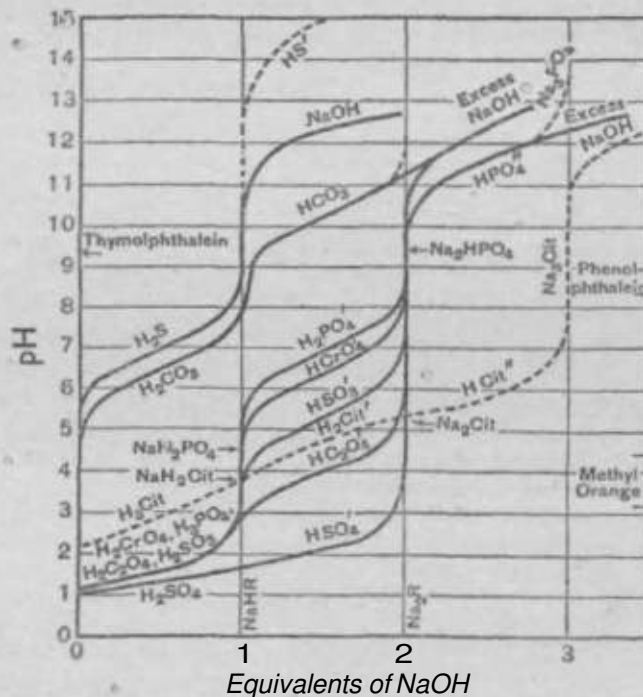

Fro. 4.

lie established in the latter instance owing to the hydrolysis of the added  $Na_2CO_3$ . The lower curve, gives the pH change if all the  $H_2CO_3$  remains in solution and none escapes as carbon dioxide. In such a case, the buffer action will be caused by



or ionically by

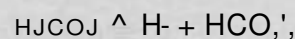

i.e.,  $pH = pK_{a1} + \log \left\{ \frac{[HCO_3^-]}{[H_2CO_3]} \right\}$ .

Actually, some carbon dioxide will be lost with a consequent reduction in  $[H_2CO_3]$  and a corresponding increase in pH,

Borax is strictly speaking an acid salt of a weak monobasic acid,  $HBO_a$ ,  $p_{ff_a}=9.34$ , for in solution it exists as

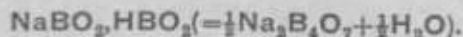

Reaction with HCl takes place thus:



The pH values after the end-point are given by  $pH = pA'_a + \log \left\{ \frac{[BO_B] \cdot [MHBO_3]}{[HBO_2]} \right\}$ , in which  $[BO_B]$  will be determined by the amount of borax added, and  $[HBO_2]$  by the boric acid liberated plus the boric acid present in the excess of borax. Thus when two equivalents of borax are added,  $[BO_2']/[HBO_2]=1$ , and the  $pH = 9.24 - \log 3 = pH \ 8.76$ .

Precipitation and pH.—Hydroxides.—The addition of alkali or ammonia to a solution of a metal salt (nitrate, chloride, sulphate, etc.) generally causes the precipitation of a basic salt of indefinite composition. In a few cases only, silver and magnesium, the oxide or hydroxide

is obtained, whilst in few cases if the alkali is slowly added, with stirring, well-defined basic salts of definite composition are obtained, e.g.,  $3Cu(OH)_2 \cdot CuSO_4 \cdot H_2O$  (see Britton, J.C.S. 1925, 2796; 1928, 2868). Nevertheless, the precipitation of basic salts depends on obtaining the concentrations demanded by the solubility product of the hydroxide involved, i.e., the metal-ion concentration and the hydroxyl-ion concentration. For ordinary analytical operations, the *oribt* of the concentration of metal ions does not vary widely, and in consequence precipitation depends mainly on the setting up of the necessary hydroxyl-ion concentration required by the solubility product. As  $K_w = [H^+][OH^-]$ , it follows that the attainment of this concentration of hydroxyl ions will be indicated by the establishment of the corresponding concentration of hydrogen ions. In other words, precipitation will depend on pH. Table X gives the pH values that must be reached before the metal hydroxide or basic salt

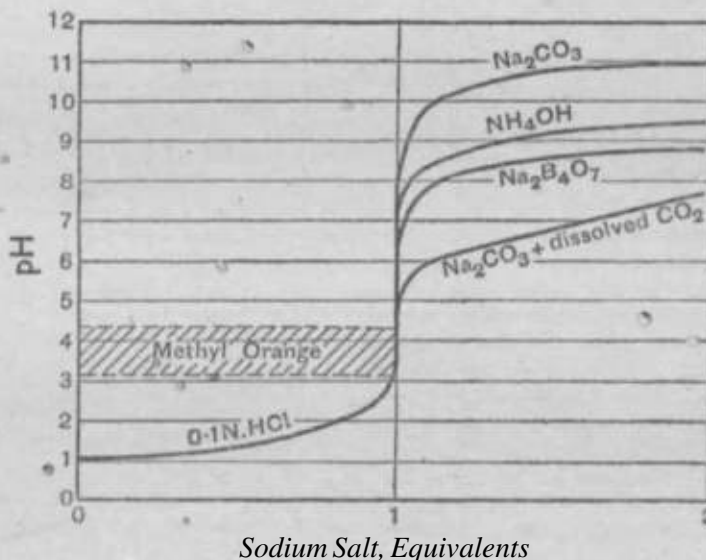

FIG. 5,

begins to precipitate from dilute solutions of salts of strong acids (H. T. S. Britton, "Hydrogen Ions," Chapman and Hall, 1942, Vol. 2, p. 79.)

TABLE X.

Salt of	pH	Salt of	pH
Mg"	10.5	Be"	5.7
Ag'	7.5-8.0	Fe"	5.5
Mn"	Be-Ba	Cu"	5.3
Hg-(Cl')	7.3	Cr-	5.3
Zn"	7.0	Al'"	4.1
Co"	0.8	Hg <sub>a</sub> "	3.0
Cd"	6.7	Hg"(NO <sub>3</sub> )	2.0
Ni <sup>M</sup>	6.7	Sn"	2.0
Pb"	6.0	Fe"	2.0

Consideration of the buffer system,

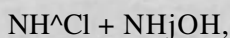

illustrated in Fig. 5 will show why  $NH_4OH$  in

the presence of a sufficient concentration of  $NH_4Cl$  prevents the attainment of the magnesium and manganese hydroxide precipitation pH values and thus prevents their precipitation.

The attainment of the hydroxide pH is the determining factor in the precipitation of basic salts of weak acids, e.g., chlorides, carbonates, borates, silicates (Britton, J.C.S. 1926, 125; 1927, 425).

Sulphides.—For the precipitation of sulphides the concentrations of metal ions and sulphide ions together must satisfy the solubility product required. Furthermore,  $[S^{2-}]$  is dependent on the successive ionisations of  $H_2S$ ;

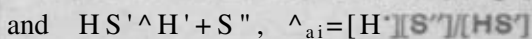
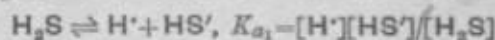

The sulphido-ion concentration,

$$[S^{2-}] = K_{a1} \cdot K_{a2} \cdot \frac{[H_2S]}{[H^+]^2}$$

is thus dependent on  $[H^+]$ , and this explains why the most insoluble sulphides only are precipitated from solutions of low pH, whereas

the more soluble sulphides are not precipitated until pH 8-9, when the solution has been rendered ammoniacal and the H<sub>2</sub>S has been neutralised to the extent, NH<sub>4</sub>HS (*cf.* Fig. 4) and HS<sup>-</sup> ion is free to ionise unimpeded by hydrogen ions.

**Carbonates and Phosphates.**—In the precipitation of carbonates and phosphates the [CO<sub>3</sub><sup>''</sup>] and [PO<sub>4</sub><sup>'''</sup>] will depend on the hydrogen ion concentration, as this is the predominant factor in the successive dissociations of the respective acids. The pH in turn will depend on the extents to which these acids may have been neutralised (Fig. 4). Thus the most insoluble phosphates, viz., FePO<sub>4</sub>, Sn<sub>3</sub>(PO<sub>4</sub>)<sub>4</sub>, Th<sub>3</sub>(PO<sub>4</sub>)<sub>4</sub>, and AlPO<sub>4</sub> precipitate from solutions at pH 2-4, whereas the phosphates of calcium, strontium, and barium necessitate values of about pH 7. It is on this that the various analytical phosphate separations are based.

For a discussion of the significance of pH in oxidation-reduction systems and in many industrial processes, reference should be made to H. T. S. Britton, "Hydrogen Ions," Chapman and Hall, 1942, Vol. II.

H. T. S. B.

COMMERCIAL APPARATUS FOR THE DETERMINATION OF pH.

GENERAL.

The growing appreciation of the significance of pH has led to a demand for reliable apparatus for its accurate determination such that commercial equipments are now available covering wide fields of application. The simplest in conception, and probably the cheapest, are based upon colorimetric methods; the majority, however, are electrometric and range from straightforward instruments for the direct measurement of electrode potentials to complex systems for the continuous recording of pH and for its automatic control within close limits. Between these extremes lies a wide variety of instruments meeting practically every requirement of the laboratory and of industry.

COLORIMETRIC METHODS.

**Indicators.**—In general, indicators are substances which impart to a solution under test a colour dependent upon its pH value, and for reasonably precise pH determination they must show a complete colour change over a short range of pH. The following greatly abridged list of such indicators is arranged in ascending order of pH.

Indicator.	pH range.
CresolRed. . . . .	0.2- 1.8
Thymol Blue . . . . .	1.2- 2.8
Bromophenol Blue . . . . .	2.8- 4.6
MetEylRed . . . . .	4.2- 6.3
Bromothymol Blue . . . . .	6.0- 7.6
Phenol Red . . . . .	6.8- 8.4
Thymol Blue . . . . .	8.0- 9.6
Phenolphthalein . . . . .	8.3-100
B.D.H. 9011 Indicator . . . . .	9.0-11.0
Alizarin . . . . .	11.0-13.0

To facilitate the rapid estimation of the approximate pH of a liquid, universal indicators are available which in the range pH 3-11 show the whole spectrum from red to violet in the correct order; in addition many special indicators are obtainable for particular applications such as the pH determination of glue or gelatin, for tests on soil, or for use in screened ultra-violet light.\*

An indicator may be used for pH determination in conjunction with a series of buffer solutions having known pH values within the range of the particular indicator. A given amount of the indicator is added to the test solution and to each buffer, the pH of the test solution being that of the buffer with which it finally matches.

**Comparators.**—To avoid the necessity for preparing a series of buffer solutions and to simplify correct matching in the case of initially coloured or hazy test solutions, comparators are available which largely overcome these difficulties. Various types are available, some of which depend upon a series of standard buffer

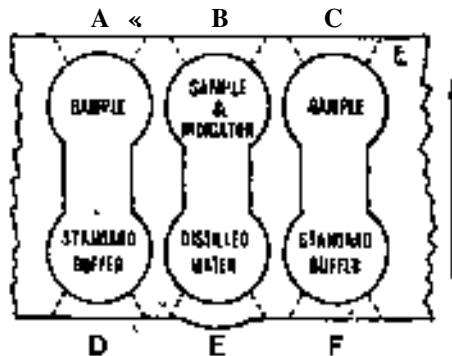

FIG. 1.

tubes while others make use of permanent colour standards; an example of the former is given in Fig. 1, in which compensation is made for the inherent colour of the liquid as shown, viewing being through the same thickness of fluid throughout. Three test-tubes are filled with the liquid under test and placed in the spaces A, B, and C of the comparator. The requisite amount of indicator is added to tube B only and in front of it, in position E, is placed a tube of distilled water. The standard buffers are placed in positions D and F and the colours compared by viewing in the direction of the arrow.

Of the types making use of permanent colour standards, which may have accuracies of the order of ±0.1 pH unit, the smaller kinds are for use with test tubes, while larger models accommodate glass cells having plane faces which present a perfectly uniform colour field for matching purposes. Such a device is briefly described below.

The instrument has two viewing apertures, the right-hand aperture disclosing a sample of the solution under test to which indicator has been added, while the left-hand aperture discloses an untreated sample in order that any initial colour of the test solution may be compensated. In front of the left-hand aperture

rotates an interchangeable disc carrying a series of transparent colour standards which pass in turn across the aperture and represent—in small steps—the exact colour changes undergone by the corresponding indicator with variation in pH value.

Having established a match between the colour standard and the treated solution under test by rotating the disc, the corresponding pH value is disclosed at an aperture near the bottom right-hand corner of the instrument.

The comparator is supplied complete with the necessary accessories, and colour dyes are available for such special applications as the pH determination of nickel plating solutions, necessitating compensation for salt errors,

#### ELECTHOMETRIC METHODS.

In view of the fact that change of pH in an aqueous solution is essentially an electrochemical phenomenon, it is reasonable that the determination of pH should be undertaken by direct

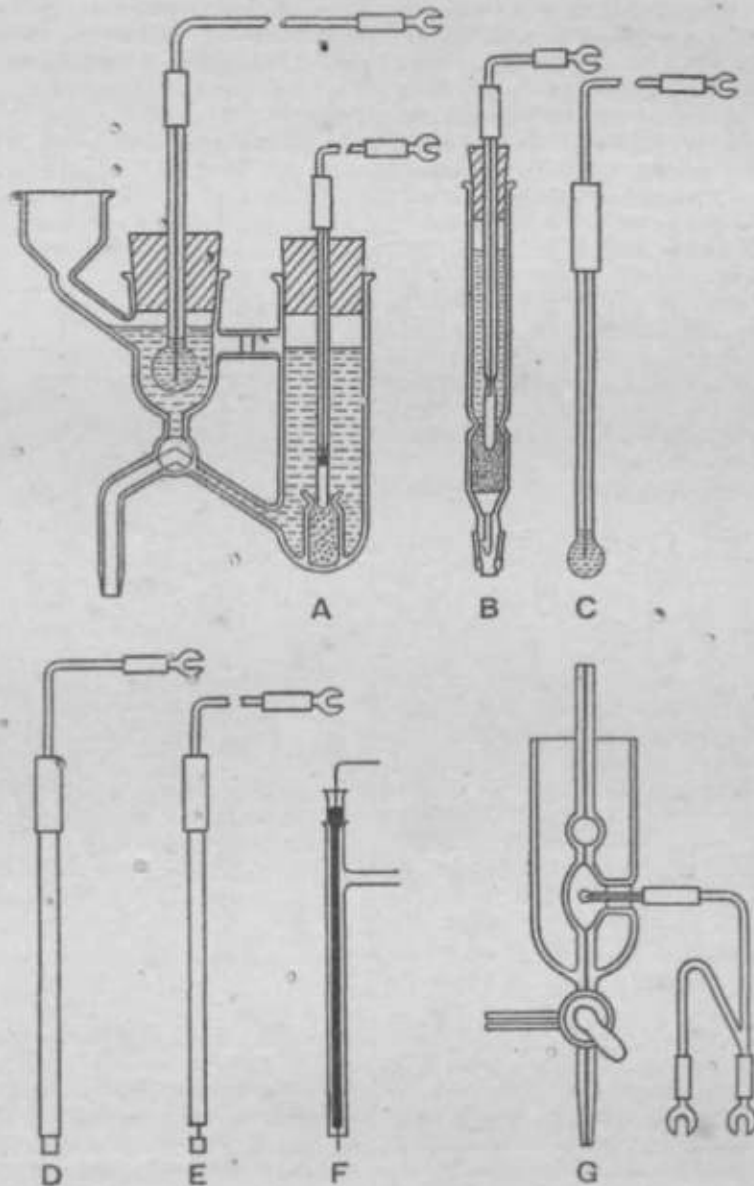

FIG. 2.

electrical means—particularly as the logarithmic nature of the unit of pH results in a substantially linear relation linking pH value with the e.m.f. developed between a suitable electrode and the surrounding solution.

The normal standard of reference is the hydrogen electrode and this type (in practice comprising an electrode of noble metal round which hydrogen gas is bubbled) is available for laboratory purposes in various physical forms. The potential  $E_H$  between the hydrogen electrode

and a solution at a temperature of  $t^\circ\text{C}$ ., derived from the elementary theory of the hydrogen concentration cell, has the following relationship with pH:

$$E_H = \frac{RT}{nF} \log_e \left( \frac{[\text{H}^+]_1}{[\text{H}^+]_2} \right) = 0.0001983(273+t)\text{pH}.$$

It follows, however, that the practical measurement of such a potential involves the introduction into the solution of a second (reference) electrode having characteristics such



that its own potential relative to the solution—ideally zero—is invariable with pH. It is also apparent that any measuring system should impose the smallest possible load on the electrode system, and further, that if a measuring device is to be calibrated directly in pH units, it must be fitted with some form of temperature compensator.

Electrodes other than the hydrogen electrode are the more largely used in commercial practice, partly to avoid the inconvenient necessity for a supply of hydrogen gas and partly because of its unsuitability in the presence of oxidising and other agents. Some electrodes in common use are shown in Fig. 2; in the figure, A illustrates a complete glass/calomel system with capillary salt bridge and three-way cock for flushing and cleaning, B shows an individual calomel reference electrode with salt bridge, while C is a sealed glass electrode and D an antimony electrode consisting of a plug of the metal fitted to the end of a glass tube. Electrode E is a platinum plate attached to a glass tube which may be used for *Eft* measurements or for pH determinations in the presence of quinhydrone. F depicts a form of hydrogen electrode through which hydrogen is bubbled; G is a specialised glass electrode assembly suitable for dealing with very small quantities of test liquid—such as blood or sera—without atmospheric contact.

Certain of these basic types are discussed below in greater detail.

**Electrodes and Electrode Systems.**—Whatever type of electrode is employed in the determination of pH, it involves the use, as pointed out above, of a second electrode which is itself immune from the effects of change in pH, the most common being the saturated calomel electrode with potassium chloride salt bridge. Such a reference system can, for working purposes, be regarded as producing a constant e.m.f. for which allowance can be made, no contact potential being developed at the liquid junction itself. The latter may take a variety of forms, but often consists of some kind of sinter, porous bung or ground glass leak through which the potassium chloride solution slowly seeps, the supply being maintained by a storage reservoir. Fig. 3 illustrates one form of construction in some detail.

Electrodes employed for actual pH determination differ widely, but the choice of basic type depends largely upon two main factors:

1. Suitability, or otherwise, for use in connection with a given application—some electrodes being adversely affected by a particular solution to be tested.

2. Whether or not a significant load is to be imposed on the electrode system by the measuring apparatus, or whether the input to such apparatus offers a virtually 'infinite impedance'—for example, an electrostatic or thermionic electrometer.

The antimony electrode is an example of the "robust" type, both in the physical sense and also in the sense that it is of low resistance and may be connected directly to a galvanometer or other current-operated device. Although the use of the electrode is subject to certain restrictions—for example, it is unsuitable in the

presence of strong oxidising agents—it is very suitable for many industrial applications and is successfully used in certain commercial pH recording systems.

The glass electrode, on the other hand, can hardly be described as robust in the generally accepted sense but has the great advantage that it is extremely versatile in application and has a linear pH/e.m.f. characteristic over the major portion of the pH scale. The greatest non-linearity which may be expected at the higher pH values is due to sodium ions—see Fig. 4; in practice this shortcoming does not by any means preclude the use of the electrode in this region, as the associated measuring equipment

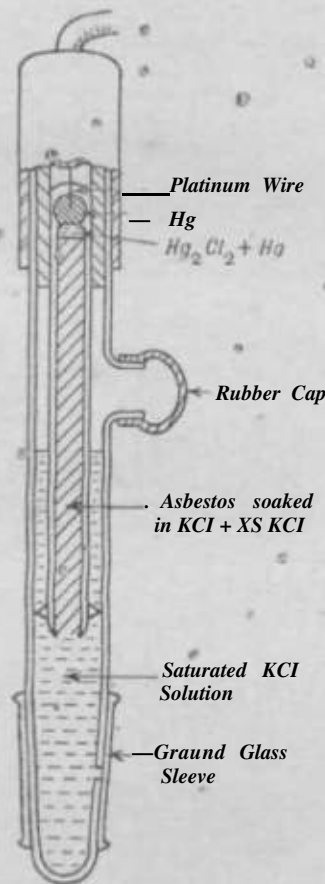

FIG. 3.

may be set up on known buffer solutions which themselves have values of the same order. Despite the fact that the inherently high internal resistance normally necessitates the use of a thermionic valve electrometer, the general advantages of the glass electrode are such that it has achieved very considerable popularity.

Commercial versions of the glass electrode differ from each other in design, but the following description of a typical product should bring out the main constructional points. The electrode under review consists of a small bulb of special low-resistance glass, about 0.05 mm. in thickness, sealed to a stem made from glass exhibiting a much greater resistance to ion transfer, errors due to variable depth of immersion thus being eliminated. The stem incorporates an auxiliary bulb, just above the membrane proper

and of larger diameter, in order to afford protection against mechanical damage. Electrical contact with the membrane is established by means of a chloride solution sealed within the bulb, an internal electrode of the silver/silver-chloride type immersed in this solution providing connection with the external screened lead which emerges through a moulded cap at the top of the stem. The general arrangement of a glass electrode with spherical membrane is shown in Fig. 5. Electrodes of this type are also available with pointed membranes for insertion into semi-solids.

While it is probably true to say that the precise functioning of the glass electrode is not fully understood in all its details, it may be crudely visualised as constituting a membrane which is pervious only to hydrogen ions; an osmotic

analogy may then be drawn as illustrated in Fig. 6.

Glass and other electrodes are commercially obtainable either individually or complete with a stand which also carries a reference electrode and thermometer or temperature compensator; one such arrangement is shown in Fig. 7, in which the reference electrode is of the type having an external reservoir. Electrodes are also available suitably assembled for industrial applications either in immersion form or for incorporation as part of a flow system. More specialised arrangements of this type are described later in the sections dealing with complete pH measuring and recording equipments.

Measuring Apparatus.—Electrodes of the low resistance type (*e.g.*, antimony, as opposed to glass) may be connected directly to a suitable

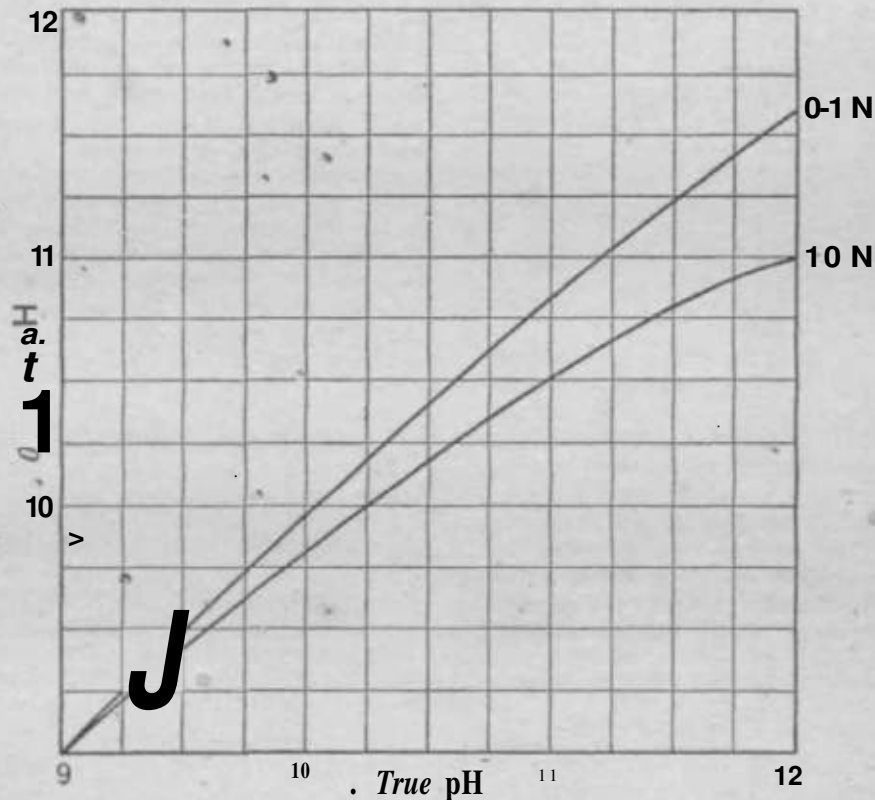

FIG. 4.

millivoltmeter; the following is an outline description of a simple robust commercial instrument designed for this purpose and particularly suitable for routine measurements or for use in schools and technical colleges; the apparatus has a total range of 1,200 millivolts and readings to 1 millivolt can be estimated. A two-position switch enables the meter to be connected to the electrodes or across a portion of an internal potentiometer for standardising, a dry cell providing the current for the potentiometer circuit.

In the case, however, of a high-resistance source such as the normal glass electrode having a resistance of the order of, say, 60 megohms (certain specialised glass electrodes have a very large surface area and correspondingly comparatively high conductance), the use of a valve

electrometer is essential and it is a usual requirement of such a valve that its input admittance should be unobtrusively small and invariable with applied e.m.f. A simple valve circuit is given in Fig. 8; in use the null indicator would first be centred with the switch in the SEX position and the condition of balance restored by adjusting the calibrated potentiometer, from which the e.m.f. from the electrode system could finally be read. It will, of course, be understood that, apart from the practicability or otherwise of such a circuit, allowance for the residual e.m.f. of the cell chain and for the temperature of the test solution would have to be made when calculating the pH value.

A number of commercial instruments function as direct reading "at a glance" pH meters (*i.e.*, the pH of the test solution is indicated by



the pointer of a meter) and are essentially d.o. valve voltmeters with the necessary addition of controls for temperature adjustment and for

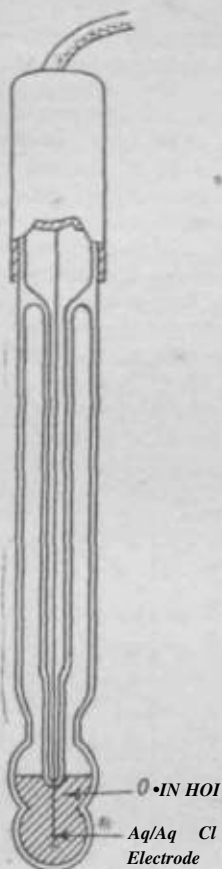

Fro. 5.

setting up against standard buffer solutions. Other types—usually of somewhat greater precision—are potentiometric in that the e.m.f. to

be measured is compared with that from a standardised potentiometer; they are elaborations of the simple circuit given in  $\text{V}\text{S. } 8.$

The following is a description of a commercial laboratory-type pH motar, a.c. mains operated and incorporating automatic temperature compensation. The instrument is essentially a sensitive electrometer of very high input resistance primarily designed for the determination of pH with the glass electrode system supplied; the control dial is therefore directly calibrated in pH units as well as in millivolts. When switched to operate as a millivolt meter, the automatic temperature compensator is disconnected.

This instrument consists basically of a precision potentiometer, standardised against an internal Weston cell with a balance indicator comprising an electrometer valve and galvanometer. The range is pH 0-11 with an accuracy of  $\pm 0.02$  pH unit, and, to simplify setting up, buffer solution tablets are provided.

Reference to Fig. 9, which gives the circuit diagram in simplified form, will show that the e.m.f. from the standardised potentiometer is applied to the electrometer valve in series opposition to the unknown e.m.f.; the valve in turn operates the bridge-connected galvanometer balance indicator. When set up for making direct pH measurements, the resistive temperature compensator is immersed in the solution under test, its function being automatically to regulate the potentiometer e.m.f. in close conformity with the relation given below,

$$E_t = E_0 + aM - 0.1983(273 + t) \text{pH millivolts,}$$

where  $t$  = temperature in  $^{\circ}\text{C}.$ ,

$E_0$  = residual electrode potential, and

$a$  = a constant determined by the characteristics of the coil chain.

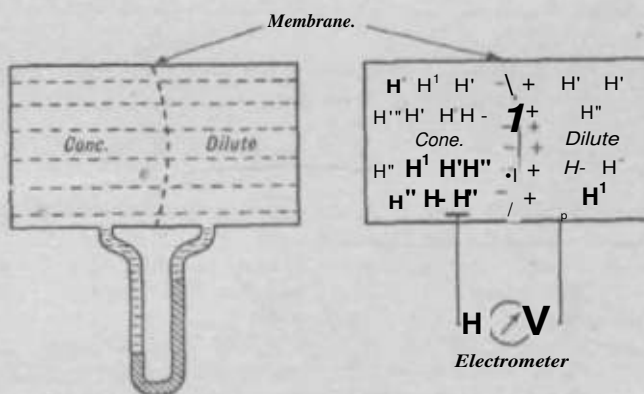

• Fio. 6.

The true pH of the solution at the working temperature is indicated. To obtain stability against fluctuations in a.c.-mains voltage, the d.c. output from the power pack—not shown on the functional diagram—is stabilised by a gas-filled relay. (For use where an a.c. supply is not obtainable, a similar instrument is available

which operates entirely from internal dry batteries.)

The electrode system is mounted on a stand removable for external use, the electrodes themselves comprising a glass electrode of the silver/silver-chloride type and a saturated calomel reference electrode with potassium chloride salt

bridge. For pH measurements on the sera encountered in biological work, a special glass electrode system is available which operates with very small volumes—0.2-0.3 ml.; a closed electrometric titration unit is also available into

which an atmosphere of inert gas may be introduced if desired. The importance of electrometric titration methods warrants a description not only of this unit, designed as an accessory for use with a pH meter, but also justifies refer-

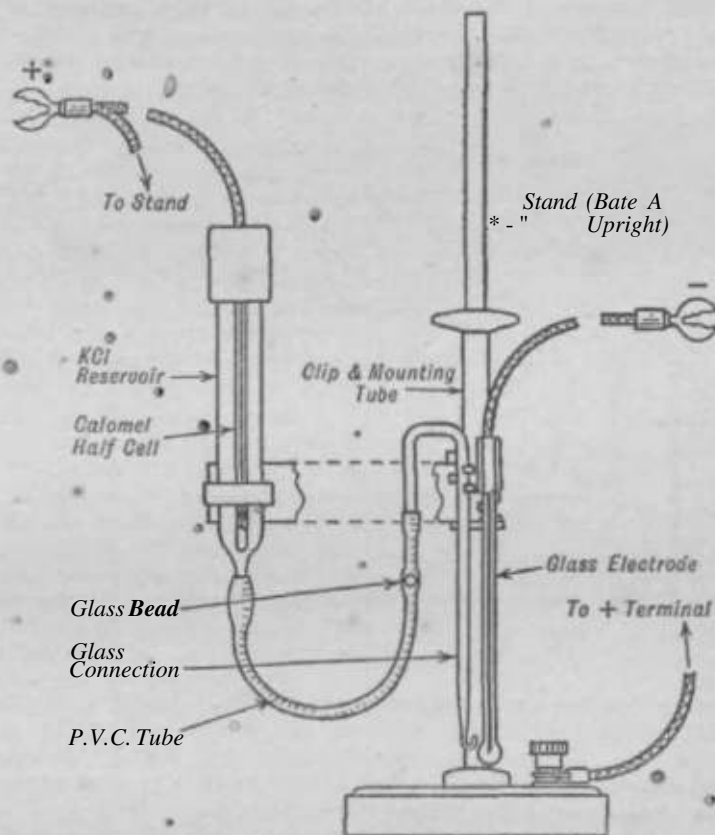

FIG. 7.

ence to complete equipments designed for this specific purpose. The electrometric titration unit in question comprises a flask containing a glass electrode and a tube terminating in a sintered disc through which the liquid junction

is made, mounted on a stand carrying a saturated calomel reference electrode and burette clamp. The reference electrode is connected to the sintered head by a rubber tubing, the other couplings to the flask also being flexible in order

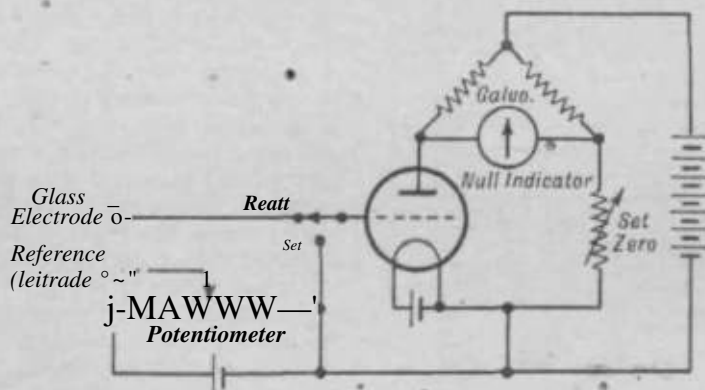

FIG. 8.

to allow mixing by swirling. The flask has two side necks in addition to a main neck terminating in a ground socket. The side necks carry the glass electrode, the salt bridge, and an inlet for purified air, while the flask head is provided with a flexible air-tight connection for the tip of an ordinary burette; it also bears an air outlet and VOL. IX.—28.

a water inlet tube with bead valve. When the end-point of the titration is being approached a fraction of a drop can be collected on the burette tip, which is then brought against the side of the internal tube of the flask head and the reagent washed into the flask by opening the bead valve on the water inlet.

The following is an example of a complete potentiometric titration apparatus—as opposed to an accessory for use with an existing pH meter—which, in point of fact, was originally designed for the analysis of steels, particularly those containing chromium and vanadium. Fig. 10 is a reproduction of a curve taken with this apparatus showing the titration of chromium as dichromate with ferrous ammonium sulphate (0.1N.). The

apparatus comprises an electrode system with motor-driven glass stirrer, a potentiometer, and a spot galvanometer incorporating a lamp and scale. The standard electrode system includes platinum and calomel electrodes, mounted on a substantial base together with a burette, a beaker, and a second burette for back titration. Special reference cells can be supplied for particular titrations.

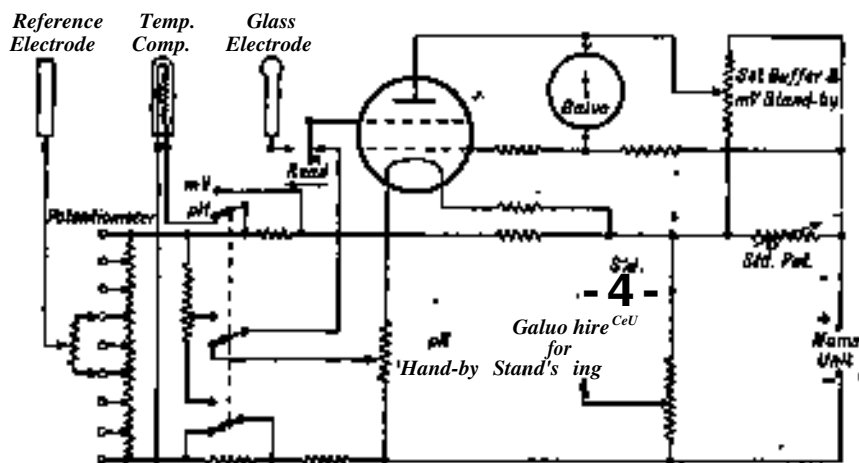

FIG. 9.

The high-resistance potentiometer is supplied by two internal cells, the dial covering a range of 0-2\*0 Y. in steps, fine adjustment being obtained by a separate control knob. The battery switch has three positions—NOBMAL, OFF, and BEVEBSE, facilitating the use of the apparatus for titrations in alkaline solutions without reversing any connections. The galvanometer has a uniform scale 160 mm. long

ability of drift during a titration sequence; it is in two sections linked by multicore cable—a titration unit and a potentiometer unit. The former consists of a cast base and column accommodating a beaker, a pair of calibrated burettes, the electrodes, and a glass stirring screw operated by an electric motor, the beaker platform incorporating a hot plate giving three degrees of heat. The following electrodes are provided: two platinum, one tungsten, one hydrogen, and one calomel.

The potentiometer unit has a somewhat unusual circuit as shown in simplified form by Fig. 11. The unit makes use of a 100-cycle-per-sec. vibrating switch which connects an amplifier circuit alternately to the unknown potential and to a known potential developed across a calibrated potentiometer circuit, the two potentials being of the same sign. If the setting of the calibrated potentiometer is such as to produce a difference of potential when compared with the unknown, then a 100-cycle pulsed waveform will appear across the input to the amplifier, which is passed to an electron beam ("magic eye") indicator. If the known and unknown potentials are identical, then no signal will be impressed on the indicator, thus showing balance; the value of the potential is given by the potentiometer system, which is calibrated from 0 to 400 mv. extended to 2,000 mv. by switching in additional resistors. Changes in potential of 2mv. are clearly indicated throughout the range.

To facilitate operation the "magic eye" is duplicated on the titration unit and arrangements are provided for introducing a small, polarising voltage to the electrode system when required.

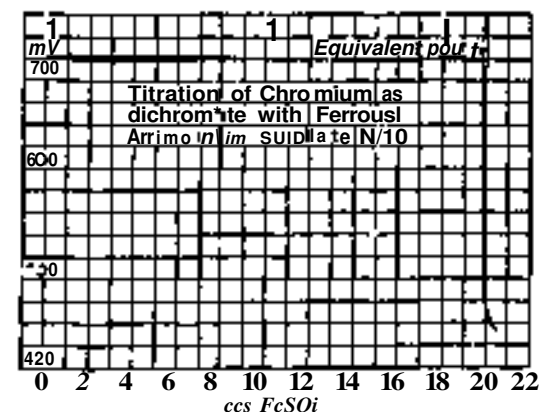

FIG. 10.

with centre zero, and the high resistance of the circuit ensures that polarisation has no serious effect on the accuracy of the titration. The approach of the end-point is denoted by temporary galvanometer deflections of increasing magnitude, the end point being shown by a sudden large permanent deflection.

A type of commercial titration equipment of special interest is arranged for a.c.-mains operation and stabilised to overcome the possi-

Recorders.—In general, pH recording equipment finds its application more in the field of

industrial process control than directly in the laboratory; such apparatus must, therefore, be of robust construction and must be capable of reliable service with the minimum of skilled attention. Commercial recorders and recorder-controllers differ in principle—except, of course,

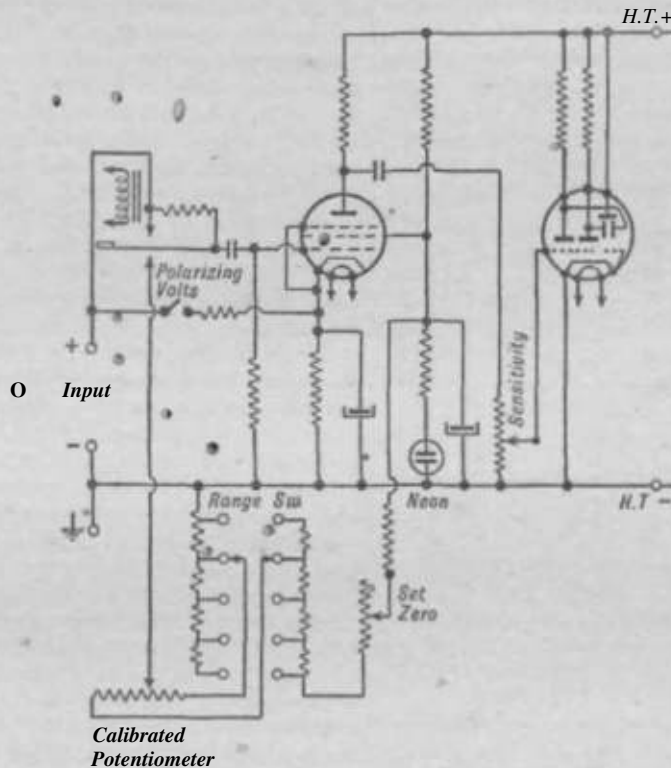

Fig. 11.

the basic one of <sup>9</sup> m.f. measurement as the means of pH determination—a widely a?do the corresponding pH meters for laboratory use. Typical examples are outlined below.

The first to be described (see Fig. 12) makes use of an antimony/calomel electrode system and the latter, complete with resistance temperature compensators, is available in several physical

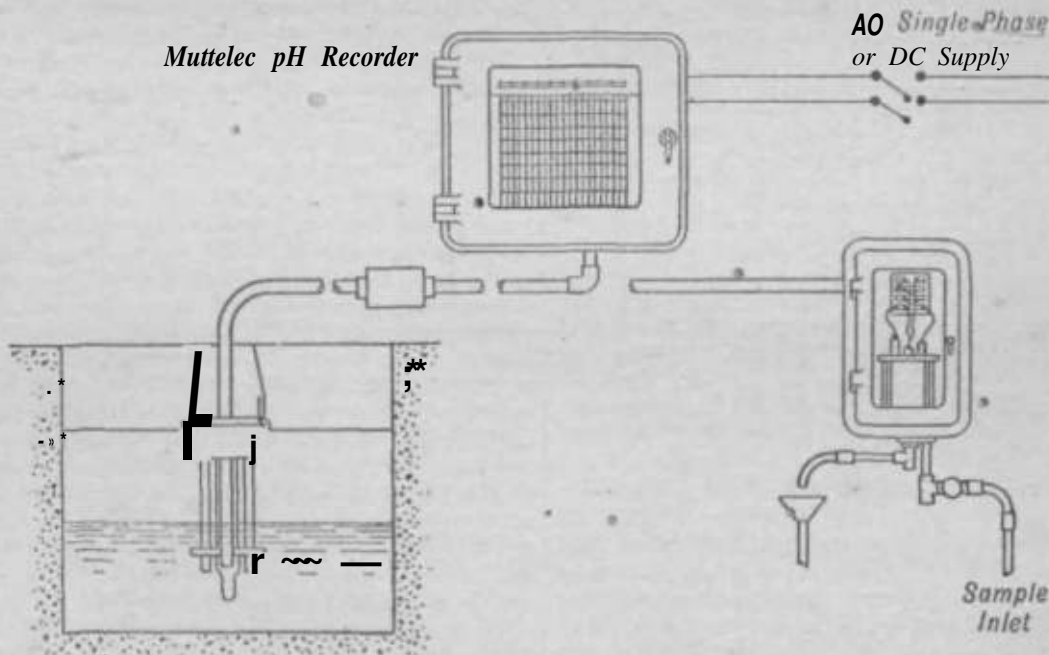

Fig. 12.

arrangements either for tank mounting or for connection to a flow system. The output from this low resistance electrode combination being adequate for the direct operation of a galvanometer without amplification, the e.m.f. from the electrodes is applied in the recorder to a potenti-

meter bridge having a special galvanometer as null indicator. Fig. 13 shows the circuit in its simplest form; the system is directly electro-mechanical and operates in the following manner.

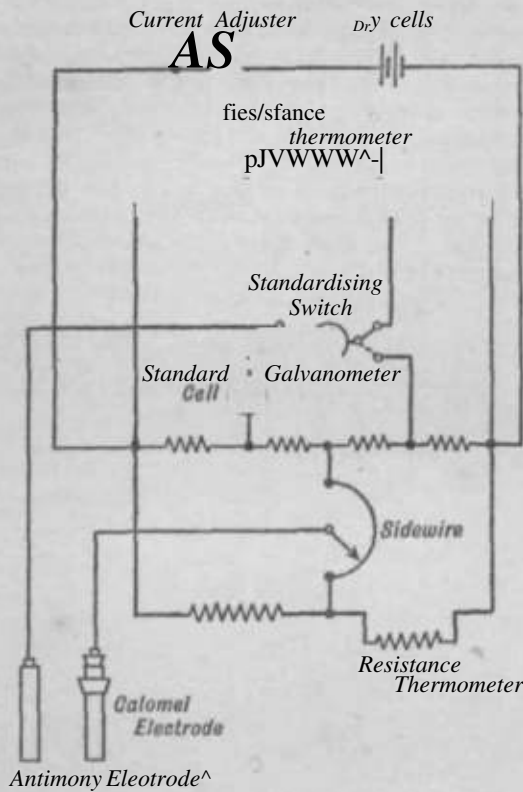

Fig. 13.

At the beginning of each cycle controlled by a small motor, the galvanometer needle is entirely unrestricted and is free to take up a position determined by the pH of the solution under test.

As the cycle progresses, the galvanometer needle is firmly clamped and its position expressed by a scissor mechanism which engages a clutch and in turn rotates a spindle an amount proportional to the deviation (if any) of the galvanometer needle from its position in the preceding cycle. This movement is recorded on a continuous 10 in. chart and at the same time a slide wire is moved to restore the balance of the potentiometer bridge. Automatic temperature correction and current standardising are incorporated, and a gearbox is provided for the control of chart speed.

Another type of recorder, in this case for use with a glass electrode, employs a self-balancing potentiometer system a special electrometer valve which presents a very high impedance to the electrodes (see Fig. 14). Any deviation from balance in the potentiometer system, occasioned by a change in pH on the part of the liquid under test, excites a sensitive polarised relay which in turn energises a step-by-step reversible impulse motor and moves a slide-wire contact until balance is restored. The contact arm is geared to a recording pen which traces the measured pH value on a rotating 100-line circular chart, driven by a clock motor, which has a radial scale of pH and a circular time-scale of 24 hours; the whole chart is visible through a window and the pen serves as a direct-reading indicator.

Power for the measuring circuit is supplied from the "a.c. mains through a rectifying and voltage stabilising system which gives an output independent of fluctuations in the supply voltage, while power for the indicating and recording mechanism is taken through a separate system so that no significant load is imposed upon the sensitive measuring circuit.

The external electrode system, which is connected to the recorder by a multi-core cable of high insulation resistance and may be of the dip

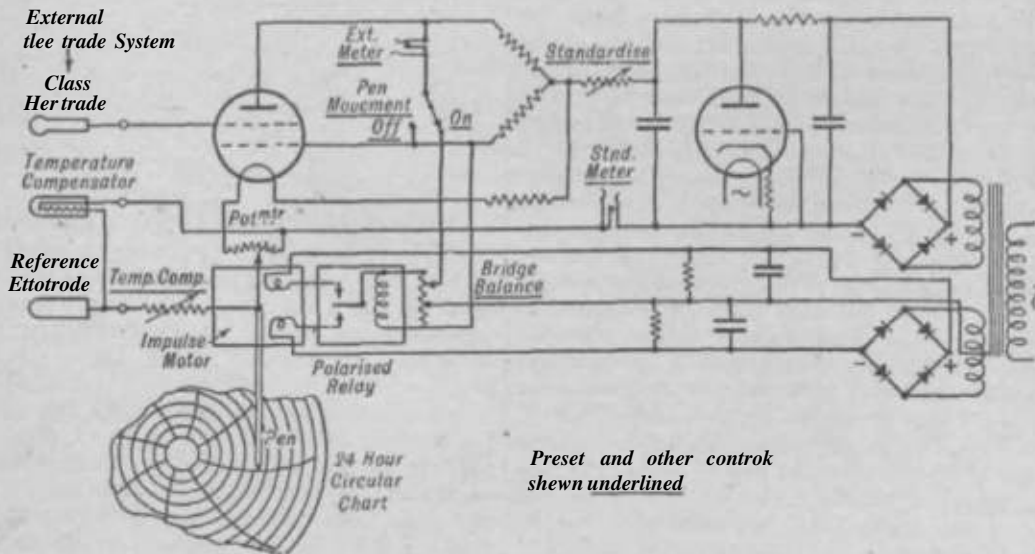

FIG. 14.

or flow type, comprises a glass electrode, a reference electrode of the saturated calomel type and a temperature compensating unit which automatically corrects the reading of the instru-

ment in accordance with the known e.m.f./temperature law of the cell. In the dip-type assembly the electrodes are mounted at the extremity of a tubular frame for immersion to a



depth of about 30 in. and are protected from mechanical damage by a surrounding cage, all electrical connections being established via a socket at the top of the assembly.

The assemblies are primarily arranged for bolting to the side of a vat or duct, but alternative fixings enable them to be introduced through the top of a vessel or hooked over the side of a vat and clamped in position by thumbscrews. The flow type, on the other hand, is a wall mounting unit for inclusion in a by-pass or bleeder on the installation, the active elements being contained in a demountable closed vessel from which air is excluded. Models are also available which are of particular use in the presence of heavy sedimentation, and in all models the liquid junction is fed from a reservoir which can be replenished while the electrodes are actually in operation.\*

Controllers.—From the continuous recording of pH, its automatic control is a natural step; in general this is accomplished by adding to the recording apparatus the mechanism necessary for the operation of dosing valves or other devices which govern the admission of acid or alkaline reagents. Where the permissible limits of pH value are comparatively wide the control mechanism may be called upon only to release the required correcting reagent at a constant rate during such time as the pH of the final effluent is outside the specified limits, but where close control is necessary—particularly when wide fluctuations in pH are to be expected—the controlling system may be called upon to inject reagent at a rate proportional to the change in pH.

The method of control may be mechanical, electrical, pneumatic or any combination of the three. In one system, for example, a valve operated by an electric motor controls the flow of supplementary alkali into a predominantly acid effluent (or vice versa) in order to raise its pH, before disposal, to a value to be maintained between certain limits. In this equipment a moving coil meter, incorporated in the controller and giving a continuous indication of the pH of the effluent, is the actual monitor of the control system and it is on the deflection of its pointer that the correction depends. The controlling linkage between the meter and the valve motor switches is a mechanical one, the switches themselves being of the glass-mercury type. Two push-plates are mounted in the instrument, equally disposed about an adjustable control index which is set to correspond with the average pH value ( $\pm 0.5$  pH unit) which it is desired to maintain, these push-plates being flexibly coupled to the appropriate ends of the mercury switches governing the valve motor; a dead zone 1 pH unit wide exists between these "high" and "low" plates. While the pointer of the meter is in the dead zone the motor remains stationary, with the alkali valve left at the setting resulting from any preceding application of correction. Depression of the "pH low" plate rotates the motor to open the alkali-admitting valve, while depression of the "pH high" plate correspondingly closes the valve.

Actual depression of individual plates is caused by the periodical falling of a presser-bar above

the plates which is cam-operated by a motor in the controller. This bar falls once every 15 seconds and remains down for a period of between 0.5 and 6.0 seconds, determined by the setting of the variable-dwell cam operating it. A stylus is so placed on the indicating pointer that, when the latter is over one of the push-plates, the stylus is interposed between the presser-bar and that particular plate, thus causing it to be depressed and so operate the associated motor switch. It will be seen from the foregoing that the setting of the variable-dwell cam operating the presser-bar determines the rate of operation of the valve, the process occurring in a series of impulses of predetermined duration. The motorised valve assembly itself comprises a split-field series of motor driving a valve-operating shaft through a reduction gear.

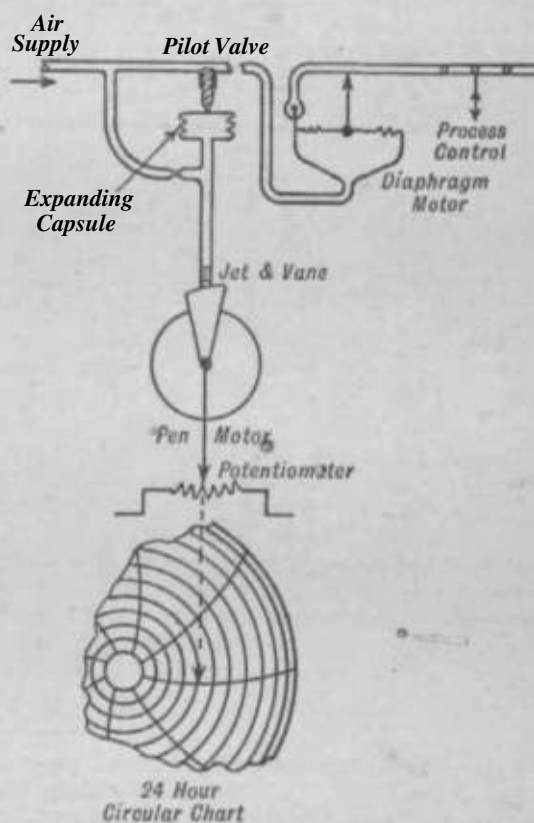

FIG. 15.

adjustable glass-mercury-type limit switches being fitted to restrict the valve travel as may be required. An additional feature of the equipment is the incorporation of a warning unit carrying three coloured lamps which light up to indicate "pH normal," "pH high," or "pH low."

In another system of control, the operation of the reagent valve or valves is pneumatic. The pH measuring and recording portion of the equipment is somewhat on the lines of the recorder already described and functionally illustrated by Fig. 14. To accomplish control a specially-shaped vane is mounted on the spindle of the like balancing system and positioned to float freely between the nozzles of a pair of opposing jets supplied, via a constriction, with compressed air at about 15 lb. per sq. in. The position of the

vane regulates the flow from the jets and hence the pressure in the jet system, this pressure being applied to an expanding capsule which operates a pilot valve in the outgoing compressed-air control line and thereby governs the main valve or diaphragm motor controlling the pH of the process. The pH value to which—within close limits—the process is to be held is determined by setting a pointer to the appropriate line on the recorder chart. The basis of the control system is illustrated functionally in Fig. 15.

The commercial recorder-controller shown in Fig. 16 operates on the pneumatic free-vane principle and is available with a choice of three

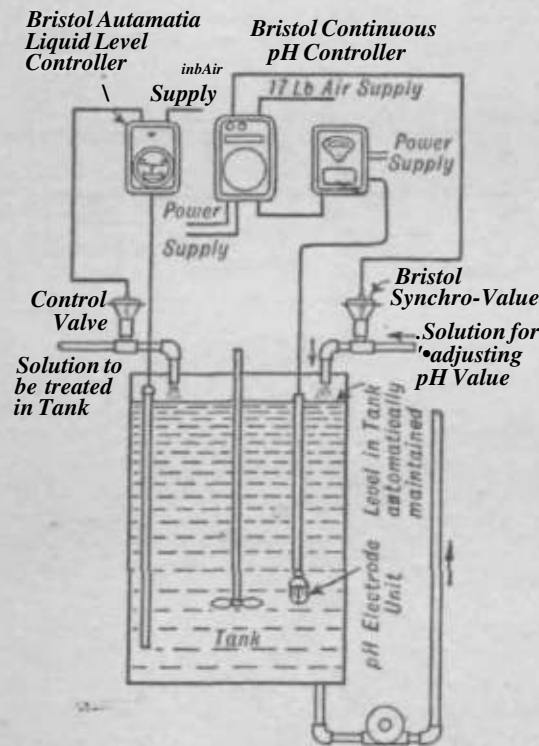

FIG. 16.

primary characteristics—narrow band proportional control with a fixed throttling range (or on-and-off), proportional control with adjustable throttling range, and proportional control with automatic reset of control point. The first two are suitable for simple control applications involving only moderate time lags; the third and more complex form of the instrument is designed to meet the problems presented where the time lag is considerable and a large change in the flow of corrective reagent may be required to maintain constant conditions. The throttling range is normally narrow but is temporarily widened in proportion to the rate of change and subsequently restored to its narrow value.

m

#### Acknowledgment.

The foregoing summary of commercial apparatus for the determination of pH is necessarily incomplete, it being hardly possible to do full justice to so wide and diversified a range of equipment within the compass of an article of essentially restricted length.

The author is indebted to a number of commercial organisations for their co-operation in providing details of their products, particularly Messrs. Baird and Tat-

lock (London), Ltd., Bristol's Instrument Co., Ltd., British Drug Houses, Ltd., Cambridge Instrument Co., Ltd., The Integra Co., Ltd., George Kent, Ltd., Marconi Instruments, Ltd., Muirhead & Co./Ltd., The Milliard Wireless Service Co., Ltd., and The Tintometer Co., Ltd.

K. H. N.

PHARBITIDIN, an anthooyanidin derived from the pigment of a red form of "Morning Glory" (*P. J. m. bilus nil*), it is identical with pelargonidin (Kataok., Proc. Imp. Acad. Tokyo, 1928, 4, 389).

W. B.

PHASE-BOUNDARY POTENTIAL (v. SUBFAGB FILMS).

PHASE RULE: APPLICATION TO THE SEPARATION OF SALT SOLUTIONS INTO THEIR CONSTITUENTS.

INTRODUCTION.

The isolation from a complex of substances of a particular solid, liquid, or vapour contained therein, or potentially present, is an essential part of many industrial chemical processes. Generally, before a specified substance can be isolated from such a mixture, it must first be formed as a separate phase. Hence, to prepare the desired substance, a knowledge of the conditions under which it can exist as a separate phase in equilibrium with the other components of the mixture is usually essential. The general relations which must obtain between the number of phases, the number of components, and the number of independently variable properties of a complex of chemical substances are, of course, formulated in the phase rule. The actual numerical values or range of values of the variable parameters, such as temperature, pressure, phase concentration, under which the specified phase can exist in equilibrium in a given complex can be determined only by experiment. Such experimental work, directed towards defining the conditions of stable existence of the possible phases of a complex, is guided by the phase rule, and the results of the experiments are interpreted by this same rule.

This article deals with the application of knowledge of heterogeneous equilibria to problems of chemical manufacture. The equilibria considered, however, are only those between solids and liquids, and in particular between salts and aqueous solutions. Systems including a vapour phase are not dealt with. The systems considered therefore belong to the class known as "condensed" systems. It is assumed that in such systems the pressure is sufficiently great to prevent the formation of a gas phase, but still sufficiently low to bring about no marked change in the solid-liquid equilibrium relations as they exist at, say, a low equilibrium gas pressure. Practical lower and upper pressure limits implied by the use of the term "condensed" are usually 1 and 100 atmospheres.

In the following discussion it will be assumed that the reader is familiar with the principles of the phase rule and its application to the description of binary, ternary, and quaternary systems. Where this knowledge is lacking, it may be acquired by a study of the phase-rule section of a number of books dealing with physical



chemistry, or, better still, from such standard phase-rule works *HB* those cited below.

- H. W. B. Roozeboom, "Die Heterogenen Gleichgewichte vom Standpunkte der Phasenlehre," Vols. I to III, 1901-1913.
- D. A. Clibbens, "Principles of the Phase Theory," Macmillan, 1920.
- A. Kndlay and A. N. Campbell, "The Phase Rule and its Application;," 8th ed., Longmans, 1938.
- A. C. D. Rivett, "Phase Rule and the Study of Equilibria," Clarendon Press, 1923.
- S. T. Bowden, "The Phase Rule and Phase Reactions," Macmillan, 1945.
- Jts B. W. Rhodes, "Phase Rule Studies," Oxford University Press, 1933.
- F. F. Purdon and V. \*W. Slater, "Aqueous Solutions and the Phase Diagram/ Arnold, 1946.

Some of these works also<sup>1</sup> contain sections which deal with the application of a knowledge of phase equilibria to process problems; more information is available in original papers as well as in other sections of this dictionary, *i.e.*, application to distillation, metal alloys, glass, and refractory materials. These subjects are not dealt with in this article, which is restricted to the behaviour of salt mixtures in aqueous systems.

In dealing with this subject, it will be necessary to discuss system types, but it will be understood that these are merely a selection from a great number of possibilities. They will, however, also serve as illustrations of many of the fundamental principles of phase equilibria to be found in the books and literature referred to above.

PHASE EQUILIBRIUM DIAGRAMS AND THEIR CHARACTERISTICS.

The preparation of any particular phase diagram requires a knowledge of its conditions of existence, and these conditions are evaluated by solubility determinations. The results of such measurements are usually represented diagrammatically. It is possible to read off from the diagram the conditions of temperature, pressure, and concentration which must be established to secure the isolation of the wanted phase. In many cases a partial or completely quantitative recipe for the preparation can quickly be deduced.

A brief description of the principal methods of the representation of equilibria in heterogeneous systems will enable a clearer view to be obtained of the use of such diagrams in solving process problems—the subject of this article.

Pressure is of course one of the factors determining solid-liquid equilibrium, but since it is assumed that it will be kept within limits where its influence may be neglected no representation of pressure is required. In a one-component system there only remains temperature as a variable. It is seldom necessary to show this diagrammatically if only one component is present, but if desired it can be represented as a straight line showing the temperature scale and

the melting-point of the component. This course is adopted when single components are being considered as parts of binary or higher order systems.

With a binary system there is in addition to temperature another variable, *i.e.*, component concentration. In such a case it is usual to

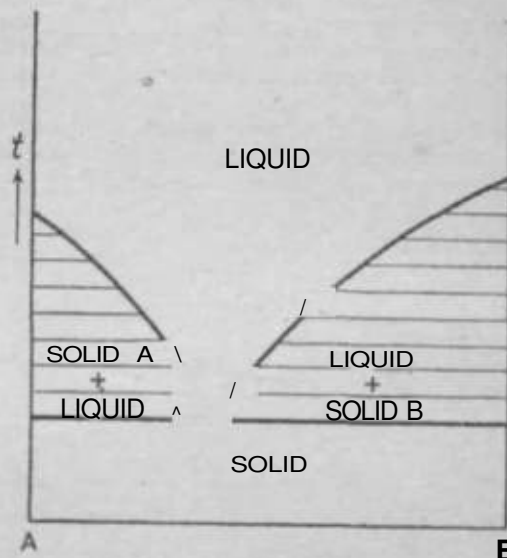

FIG. 1.

plot the solid-liquid equilibria on a plane diagram with rectangular co-ordinates, plotting temperature vertically and component concentration horizontally, *e.g.*, in Figs. 1-8. A and B represent pure A and pure B respectively. A point H (Fig. 2) represents a mixture containing EB parts of A to HA parts of B. Vertical

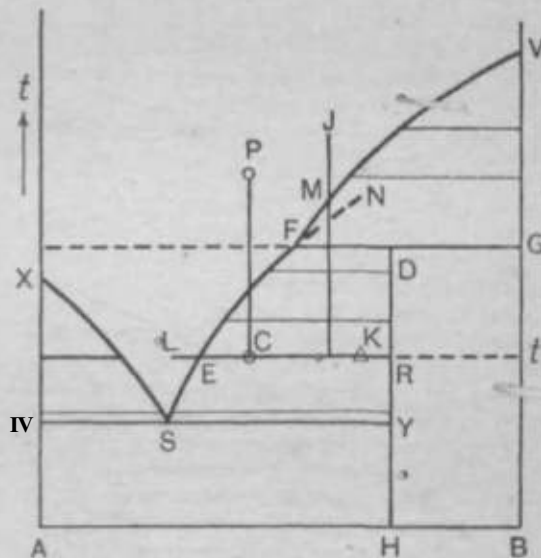

FIG. 2.

lines at A, n, or B represent the corresponding constant compositions at different temperatures, horizontal lines show varying compositions at constant temperature.

In ternary systems the usual representation consists of an equilateral triangle drawn for each temperature. The triangle corners represent the pure components and any given com-

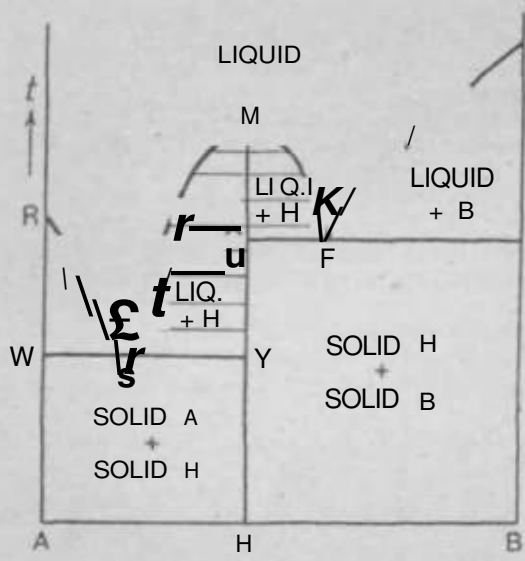

FIG. 3.

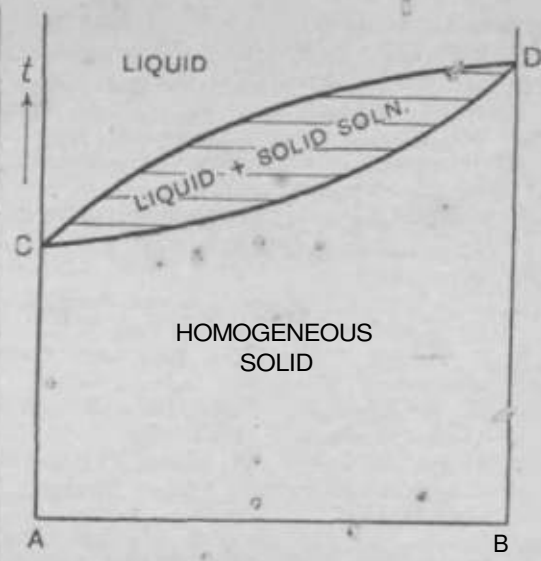

FIG. 6.

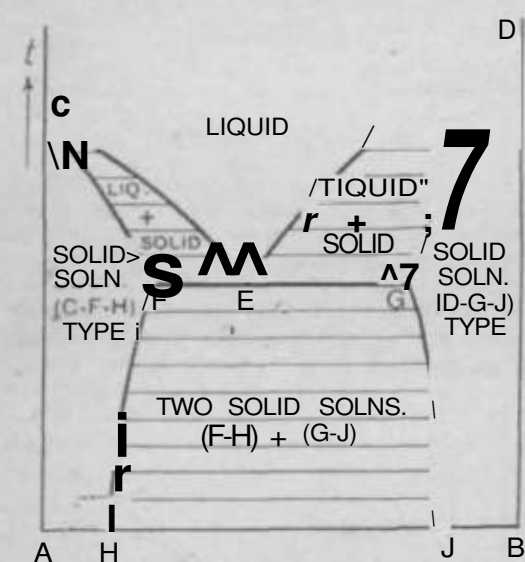

FIG. 4.

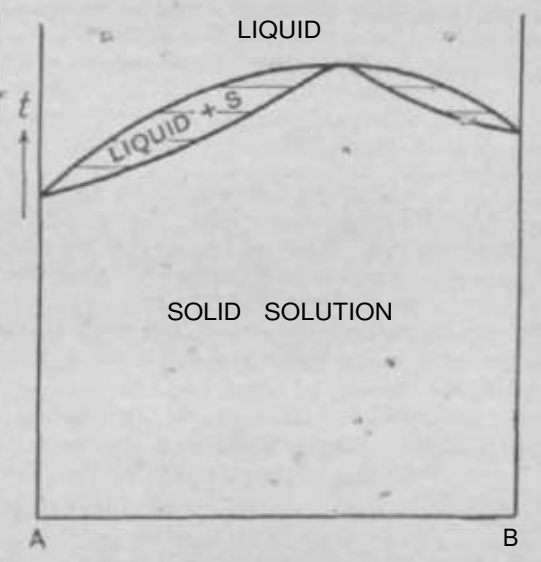

FIG. 7.

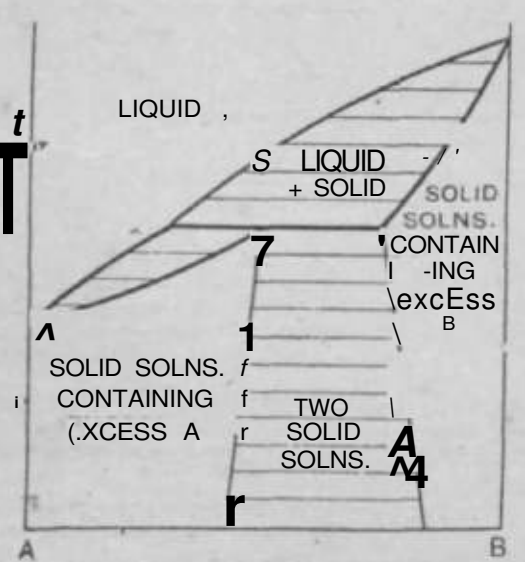

FIG. 5.

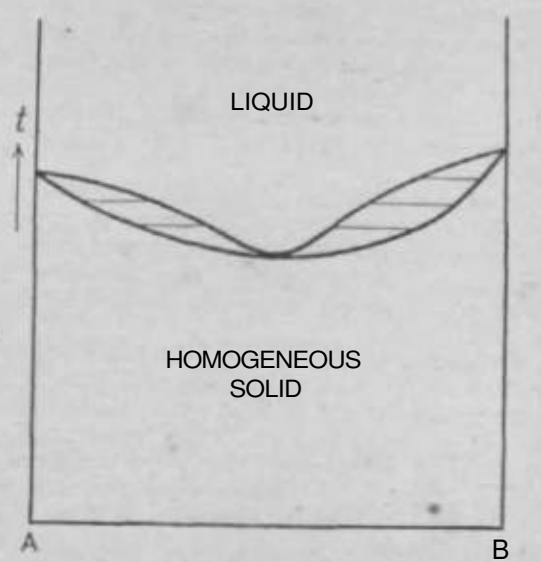

FIG. 8.

position can be plotted on the principle illustrated in Fig. 10. To show temperature changes, a space diagram is needed and a triangular prism is normally employed. A variation of the equilateral triangle is sometimes used. This is somewhat similar to the binary representation, the ratio of the concentration of two salts is plotted horizontally and the quantity of solvent,

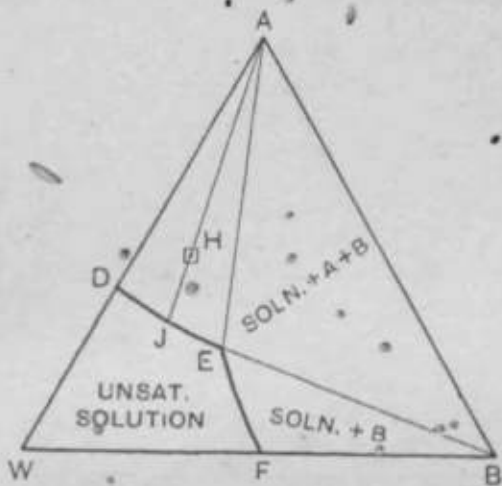

FIG. 9.

e.g., water, is plotted vertically (Figs. 9 and 11 show a ternary isotherm plotted by each method).

Four-component systems can be divided into two types which require slightly different methods of representation:

- (a) System containing a "solvent" and three salts with a common ion
- (b) System consisting of a solvent and reciprocal pair of salts which can undergo double decomposition, e.g.,

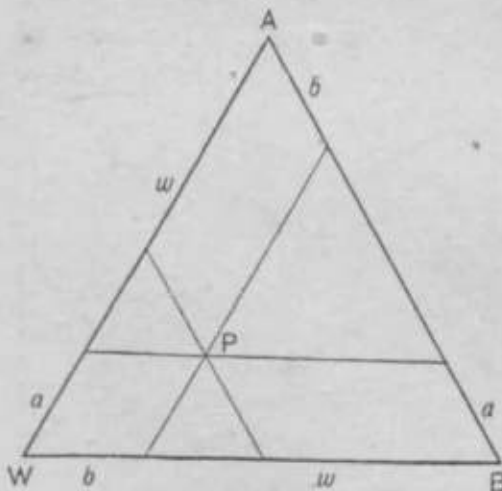

FIG. 10.

For representation purposes, a three-dimensional diagram is required in either case, (a) or (5), and the following methods are available:

- (a) (1) Tetrahedron with pure components represented at corners (Schreinemakers).

- (2) Triangular prism, three salts at corners of base and water vertical (Janecke).
- (b) (1) Pyramid on square base—pure salts at corners of square base and pure water at the apex (Lowenherz).

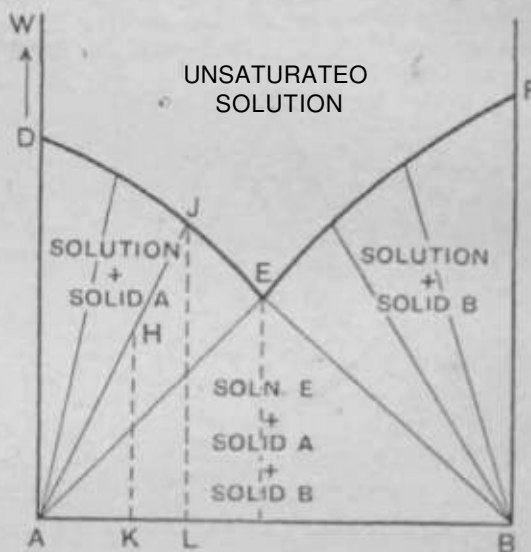

FIG. 11.

- (2) Square prism, the square base of which again represents the four anhydrous salts and their mixtures. Water plotted vertically (Janecke).

Since the Janecke method is more generally used by modern authors, this type of plotting will be described.

For the common-ion type of quaternary system, (AX—AY—AZ—H<sub>2</sub>O) or (AX—BX—CX—H<sub>2</sub>O), it is necessary to express the phase or mixture composition as the amount of each

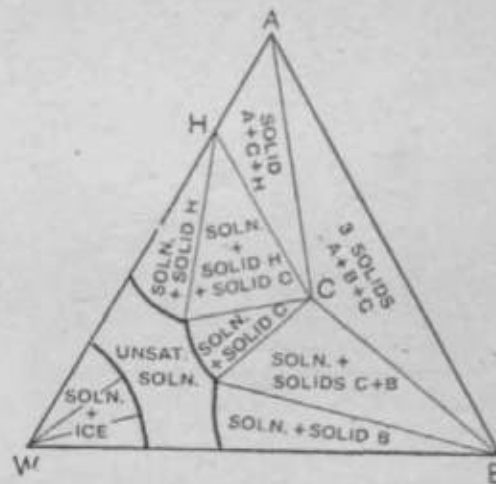

FIG. 12.

component present per 100 parts AX+AY+AZ or AX-j-BX+CX, then to plot the ratio AX/AY/AZ as on the triangle (Fig. 15), and the associated water vertically. The units may be either weights or gram-molecules.

In a reciprocal salt-pair, AX+BY-j-H<sub>2</sub>O = i AY-j-BX+H<sub>2</sub>O, the composition of any phase

or mixture can always be expressed in terms of three of the possible salts and water. Usually it will be desirable to calculate first to weight percentages, but these must then be converted to molecular units. The ionic ratios  $A/8$  and  $X/Y$  are then calculated, whilst the  $H_2O$  present is expressed as molecules of  $H_2O$  per 100 molecules of the three salts present. The plotting of the ionic ratios in the salts is then effected as shown

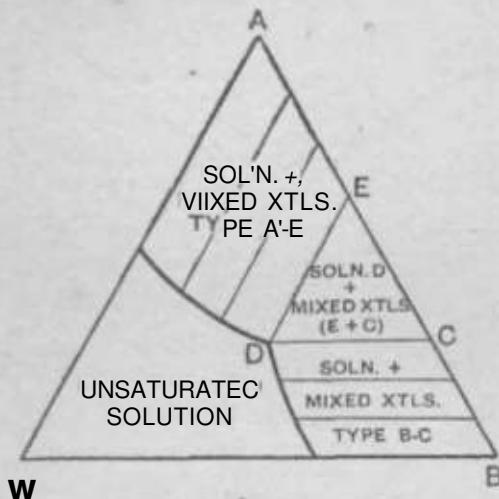

Fig. 13.

in Fig. 18. Here it will be seen that  $AX-AT$  contains 100% of ion A,  $BX-BY$  has 100% ion B,  $AX-BX$  has 100% ion X and  $AY-BY$  has 100% ion Y. Lines parallel to  $AX-AY$  and  $BX-BY$  represent constant ratios of A/B and lines parallel to  $AS-BX$  and  $AY-BY$  constant ratios of X/Y. The intersection of two lines at right-angles, such as lines PQ and as intersecting at T, fulfil the conditions for any

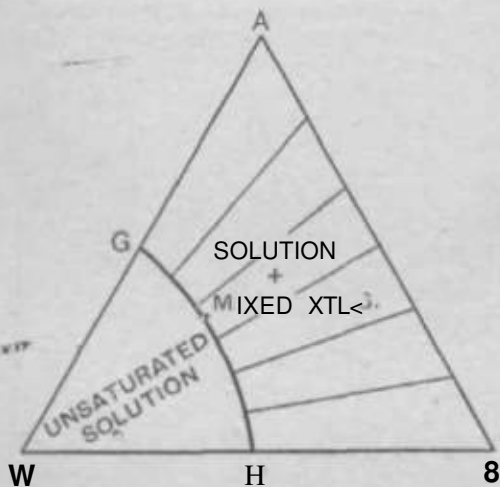

Fig. 14.

pre-determined ionic ratios. Having fixed the position of the point representing the salts, it only remains to plot the associated water vertically.

In four-component systems, whether of the common-ion or of the reciprocal salt-pair type, the vertical sides of the space diagram represent the subsidiary ternary systems plotted as in Fig. 11. The two-solid-phase solution points such as B become the starting points for two-

solid-phase curves. These curves intersect in one or more three-solid-phase points and enclose surfaces representing solutions which are in equilibrium with one of the solid phases. Figs. 16 and 19 are perspective views of space diagrams for simple types of four-component system. Fig. 16 relates to the "common-ion" type and Fig. 19 to reciprocal salt pair.

Space models are extremely valuable and often

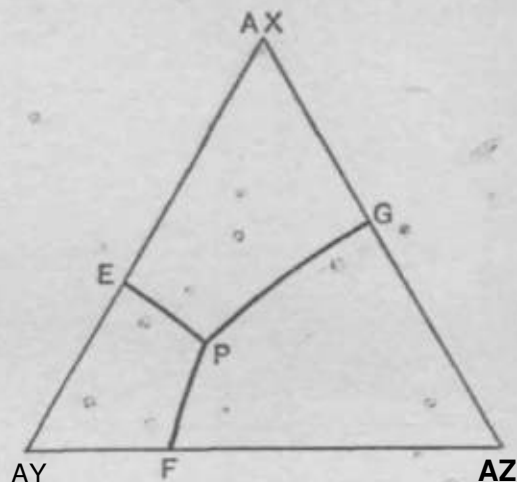

Fig. 15. -

enable one to observe characteristics and developments otherwise missed. In most cases, however, it is necessary to use two-dimensional projections and, as will be seen later, at least

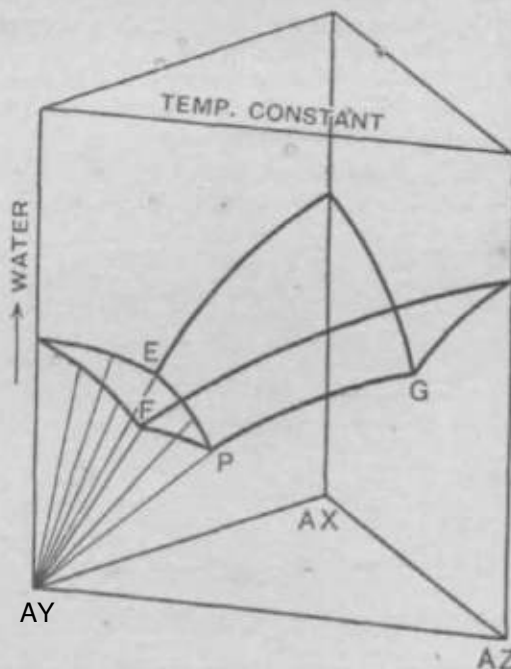

FIG. 16.

two projections are needed for any space diagram. A favourite projection is one on the horizontal base which shows the proportion of salts or ions present and which, of course, excludes water. Such a projection for a common-ion system is shown in Fig. 15 and a similar one for a reciprocal salt pair in Fig. 20. Iso-water

curves can, feowover, be added to such projections as in Fig. 21.

In th% common-ion type, at constant temperature (t.g., Fig. 15), these are projections of:

T)ree surfaces, . AXGPH, ATEPF, and AZOFF, for solutions in equilibrium with the single solid phase\* AX, AY, and AZ, respectively.

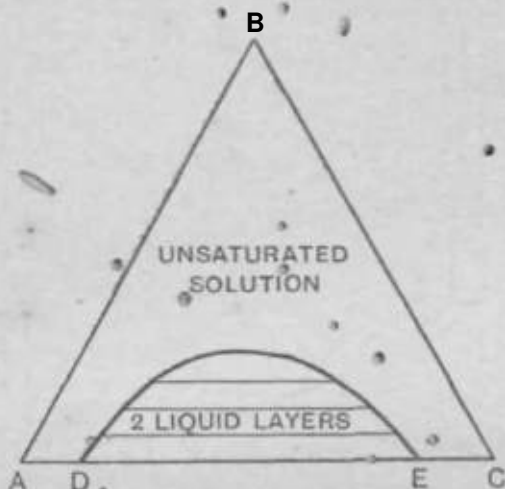

Fig. 17.

Three curves, EP, OP, and FT, for solutions in equilibrium with AX-hAY, AX+AZ, and AY+AZ, respectively.

One fixed point, P, representing a solution in equilibrium with the three solids AX, AY, and AZ.

In the simplest type of reciprocal salt pair, e.g., Fig. 20, the number of "ofa-solid-phase"

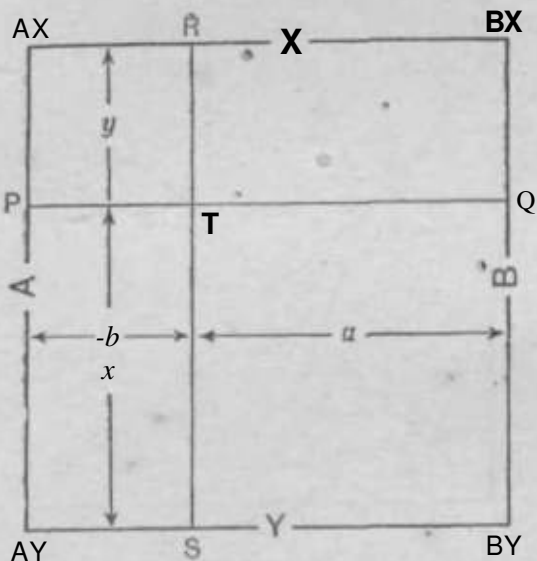

FIG. 18.

surfaces is increased to four: AXJFED {Solid AX), BiOEFH (Solid BY), AYDEQ (Solid AY), and BXJFH (Solid BX). There are five two-Bolid-phase curves: DB (AX+AY), GE (AY+BY), JS (AX+BX), IIF (BX+BY), and EF (AX+ BY). Finally there are two solutions, E and F, each in equilibrium with three solids, a (AX+AY+ BY) and F (AX+ BX+ BY).

Equilibrium diagrams, whether plane or three-dimensional, serve a two-fold object. They are pictorial records of experimental work and by the application of geometrical principles they enable one to define phase compositions for all parts of thB system which is represented. For this latter purpose, the diagrams should not be

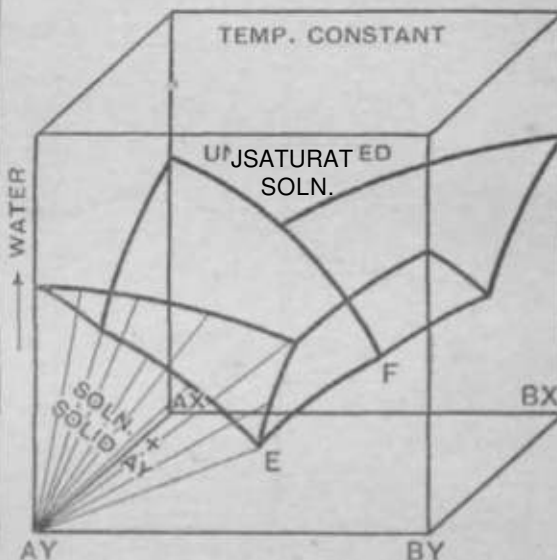

FIG. 19.

considered merely as collections of solubility points or curves but rather as portraying areas and/or volumes bounded by the curves. This will be clearer from Figs. 1-8, which illustrate binary systems at varyThg temperatures, as well as from Fig. &-14 for ternary systems at constant temperatures, and in Figs. 20-23 which are

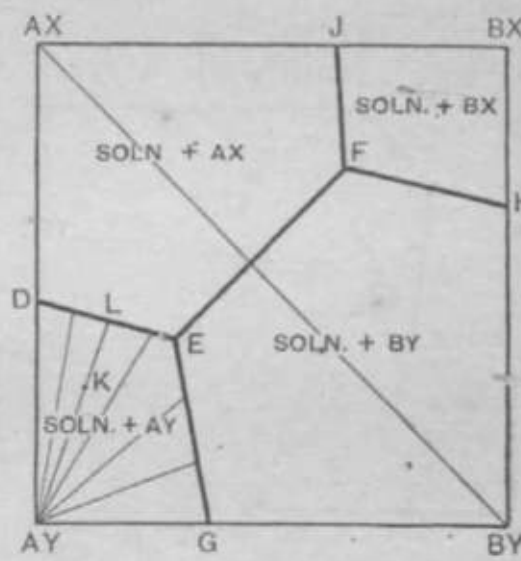

Fig. 20.

projections of isotherma space diagrams for quaternary systems.

In the above-mentioned figures, the various areas, etc., have been labelled with the names of the phases to which they correspond. Such treatment considerably enhances the value of the diagrams.

Where an area represents a mixture of two



phases, it is advantageous to conceive it as built up of an infinite number of "tie-lines"; these are lines connecting the composition of phases in equilibrium and consequently at the same temperature. In some cases we have a solid of constant composition in equilibrium with a variable liquid phase (Figs. 1-3, 9, 11, 12, 13,

temperature  $t_x$ ) will represent all possible mixtures ("complexes") of saturated solution E and solid phase H. For any selected point such as c, this composition will, at temperature L and under equilibrium conditions, yield solid H and saturated solution E in the proportion of EO parts solid to RO parts solution. In an isothermal

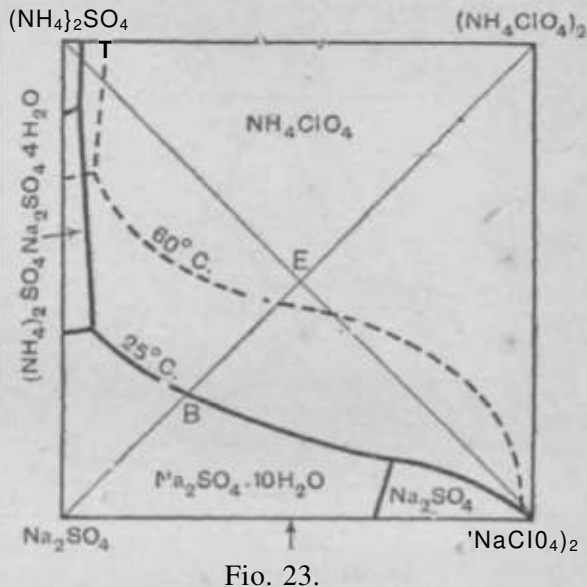
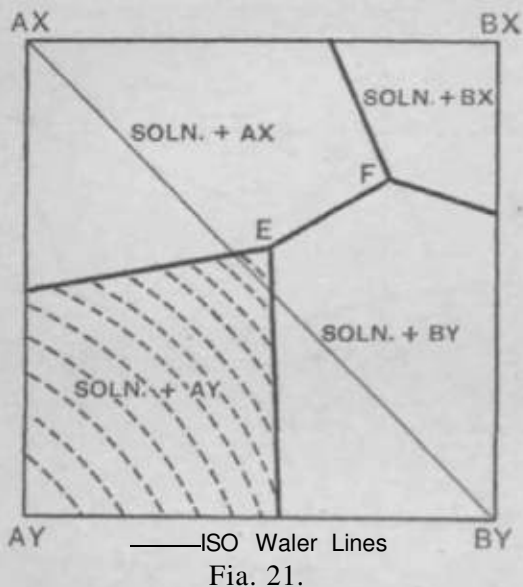

19, 20-23). Other possibilities include two variable liquids (Fig. 17), a solid and liquid each variable (Figs. 4-8, 13, 14). In binary diagrams where temperature is plotted vertically, the "tie-lines" are horizontal and in isothermal ternary and quaternary diagrams they radiate from the point representing the solid phase.

ternary system such as shown by Fig. 9, the point II on tie-line AJ represents a mixture of solid A and saturated solution J in the proportion HA parts solution to HJ parts solid. When using a two- or three-dimensional diagram in which is plotted the ratio of salts in the phases, it is important to remember that the

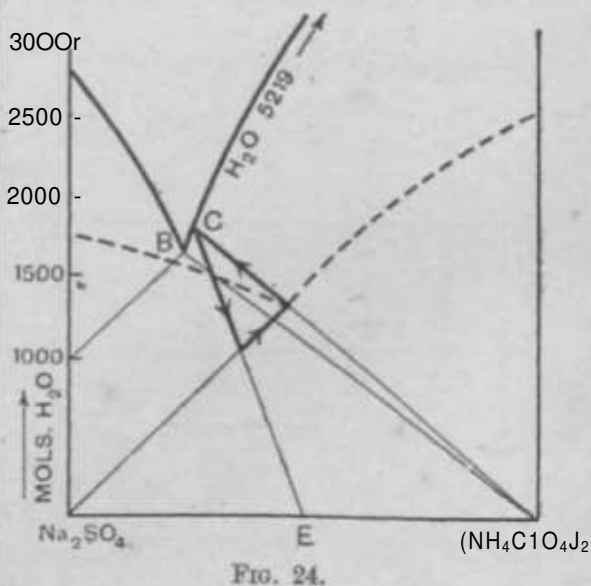
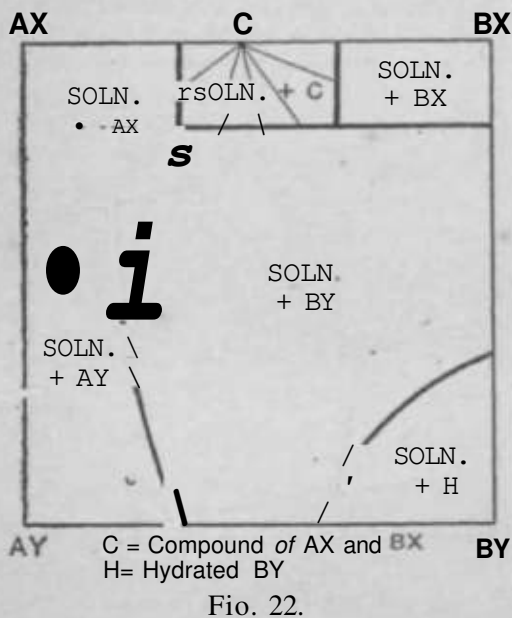

becomes even greater when it is realised that every point on an individual line represents a mixture of the two phases represented by the end points. In addition, the position of any intermediate point denotes the proportion in which the two phases are present. Thus, in Fig. 2 (binary), points on the tie-line ER (tem-

proportion rule relates to the amounts of salts in the solution and of salts in the solid phase. Moreover, this limitation still holds in a ternary diagram, such as Fig. II, or binary diagrams for quaternary systems BUCQ as Figs. 16, 19. In Fig. II, it will be clear that in the case of the mixture of a on the tie-line AJ, the ratio HJ/HA is the same as KL/KA, which relates to anhydrous salts alone.

**DIAGEAM REPRESENTATION OF PROCESS OPERATIONS.**

The methods for representing diagrammatically the equilibrium between solids and liquids have now been outlined very briefly. Such diagrams can be put to valuable use in many chemical processes which involve the separation of solids from liquids. The liquids resulting

- (c) Addition or removal of water.
- (d) Addition of solids, i.e., raw materials.
- (e) Filtration of separated solids, either the main product or a by-product.

These operations can be represented on phase-equilibrium diagrams and it will be of advantage to illustrate them on these before proceeding to deal with typical problems.

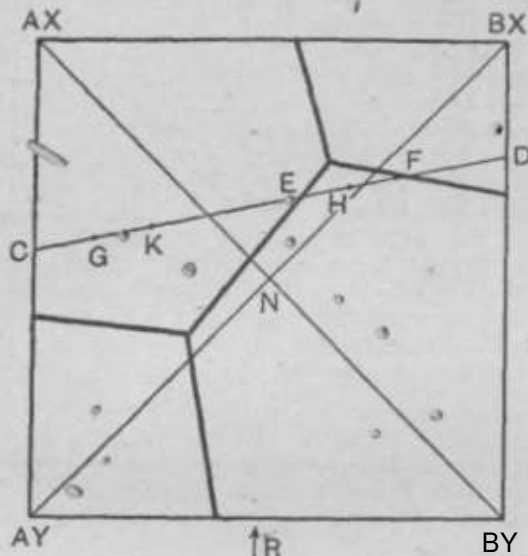

FIG. 25.

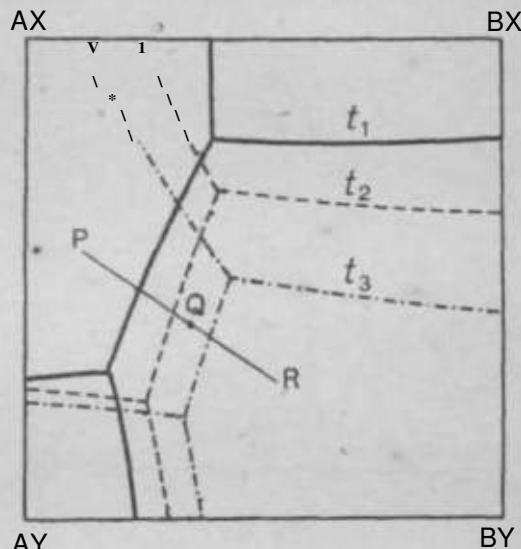

FIG. 27.

from such separations known as "mother-liquors" are, of course, saturated with the solid which has been separated. A complete knowledge of the conditions under which different solids exist enables any one of them to be separated under those conditions most suitable for ensuring purity and good volume yields.

**Change of Temperature.**—In binary systems such as Fig. 31, change of temperature corresponds to an up or down movement such as the vertical line OH. In three-component systems, a space model is required to show temperature change, but it is often convenient to superimpose curves for selected temperatures on the same diagram, such as has been done in

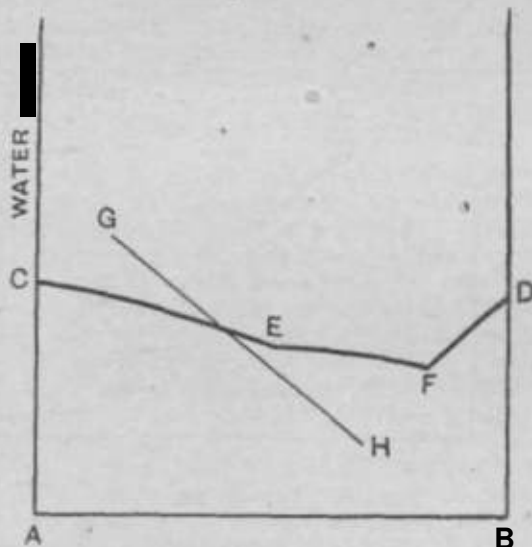

FIG. 26.

Preparations of the above-mentioned type usually include a number of well-known operations—the principal of these are as follows:

- (a) Change of temperature.
- (b) The mixing of solids or liquids of different compositions.

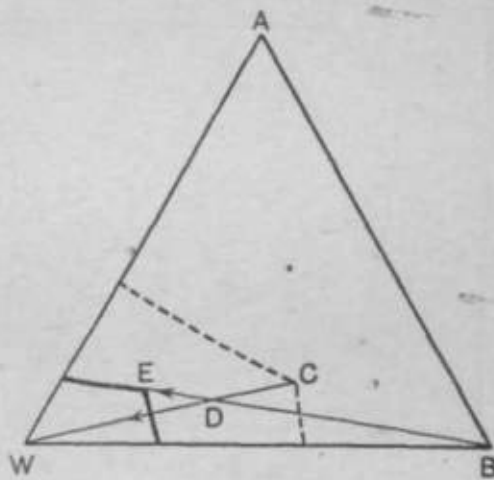

FIG. 28.

Fig. 30 for two isotherms. It will then usually be found that the complex may lie in different areas for different temperatures, and its behaviour can be predicted accordingly. With four-component systems it is impossible to show continuous temperature changes even with a space model. It is sometimes convenient to plot two or more isotherms within the same model



and to project these as in Fig. 27. The amount of information which can be obtained from a diagram of this sort is very limited unless horizontal projections to show changes in water content are also made. However, certain deductions can be made, as for example: point P can yield solid AX in a pure state if the water concentration is kept within certain limits for the isotherm concerned, and similarly for point B.

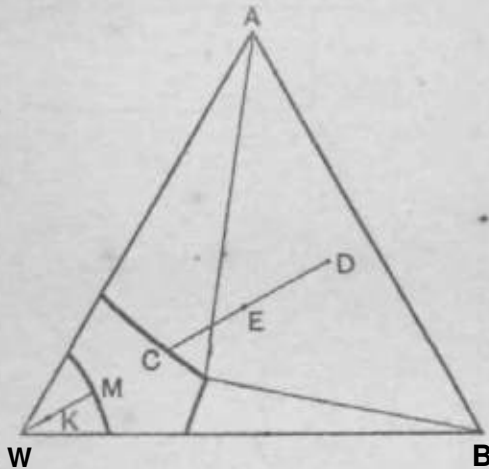

Fig. 29.

solid BY. Point Q, however, can yield either AX or BY if the water content and temperature are suitably adjusted. Insufficient water will in all cases give complexes containing more than one solid phase.

**Mixing of Complexes.**—When operating with two-component systems it is usual to postulate mixing at constant temperatures. Since orthodox phase-equilibrium diagrams do

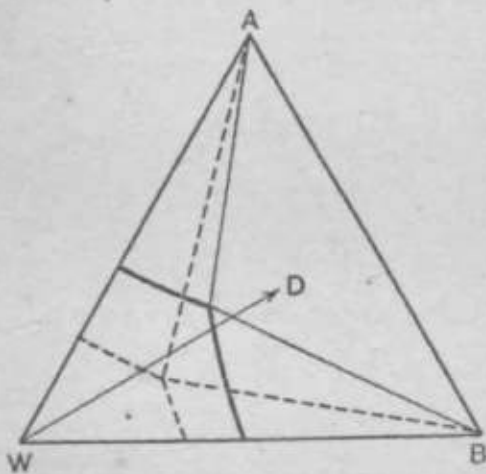
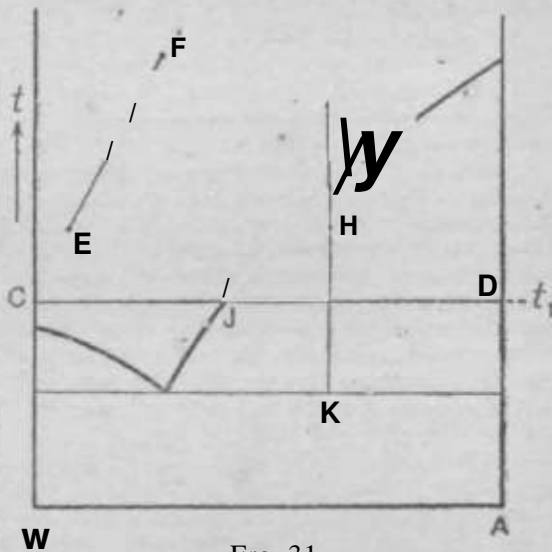

FIG. 30.

not show the effects of heat of dilution or heat of solution, it should be borne in mind that it may be necessary to add or remove heat to keep the temperature unchanged. If in Fig. 31 water at temperature  $t_x$  is mixed with component A and the temperature kept constant, the resulting complex lies on the horizontal line OD. A complex corresponding to a point such as J on this line is prepared by mixing water and A in the ratio JD to JO.

It is unusual in a diagram such as Fig. 31 to consider cases where the mixtures are joined by an oblique line such as EF. The mixing of two complexes having different temperatures can only be dealt with satisfactorily in a Merkel diagram in which concentration of components is plotted against total heat content instead of temperature. No difficulty then arises, but the consideration of such enthalpy diagrams is outside the scope of the present article.

If in a three-component system, e.g., Fig. 29, we mix solution O with complex D and adjust the temperature to that of the isotherm, all mixtures will lie on the line joining O and D, e.g., mixture E will be obtained by mixing O and D in the proportion of BD/EO. Turning to a four-component diagram such as the reciprocal salt pair, Fig. 25, it is necessary to remember that this diagram shows only the ratios of the solids present in solution. If we mix complexes whose solids are represented by O and H, all mixtures lie on the straight line OH, but it is important to remember, in applying the "proportion" rule



Fro. 31.

which has already been given, that it relates only to the dissolved salts and not to the total complexes. The point K on the line OH represents a complex which can be prepared by mixing O and H so that the solids are in the proportion of KH parts of solids G to KO parts of solids H. Even in the space model from which Fig. 25 is projected, we are faced with the same limitation when considering ratios of components.

It is of interest to examine (Fig. 26) a vertical section of the space model through the line OH of Fig. 25. This section cuts one-solid-phase curves of ternary systems at O and D and quaternary two-solid-phase curves in K and F. In Fig. 26, the section is viewed in the direction of arrow s in Fig. 25 and it has been assumed that O is an unsaturated solution whilst H contains solution and solid.

**Addition or Removal of Water.**—It has already been stated that in binary systems such as Fig. 31, the effect of dilution is shown by a horizontal line moving to the water side of the diagram, and that the proportional rules apply. In a three-component system, the addition of

water moves the complex in the direction of the water corner of the diagram, as shown in Fig. 28. Thus, solution c, when diluted to D, gives a complex lying on the line BE. To reach this point D, we mix water and solution c in the proportions of DC/WD.

Removal of water, of course, follows the opposite rule to addition of water. Solutions or complexes move in a straight line away from water when the latter component is removed. In two-component systems the line is horizontal; in three-component systems evaporation lines radiate from the water corner, e.g., wa in Fig. 30. In four-component systems, water changes position unless we have a horizontal view of the space model and it is essential to construct such projections when dealing with a problem involving four-component systems. In the removal of water, there exists a special case in which water may be removed as ice for certain solutions below 0°c., e.g., solution K in Fig. 29 at the isotherm temperature will deposit ice and move to M.

**Addition of Solids, e.g., Raw Materials.**—As with the addition of water, these are merely special cases of mixing in which the material to be added is usually represented by one of the corners of the diagram. A special case exists with the reciprocal salt pair where we sometimes add, at the same time, equivalents of the incompatible. These are represented by the intersection of the diagonals of the square projection, e.g., point w in Fig. 25.

**Separation of Solids.**—These follow the same rule as the removal of water—the complex composition moves in a straight line away from the solid which is being separated by filtration or by other means, e.g., in ternary diagram, Fig. 28, complex, D may be filtered to separate solid B and solution E.

A similar principle will apply in four-component systems, but again this can only be fully represented if one examines horizontal as well as vertical projections of the space model.

PRINCIPLES OF APPLICATION TO PROCESS PROBLEMS.

**Preparation of Salt Hydrates, and Compounds.**—The preparation of compounds in binary and ternary systems can theoretically be accomplished by bringing together the correct amounts of the components required to form a dry compound, provided that the operation is carried to completion at a temperature where the compound is stable. In practice, however, this method will seldom produce a compound of uniform composition with well-defined crystals, since the product will be found to contain inclusions of one or other of the system components. The preparations are best carried out by crystallising the wanted compound from solution, either by cooling or by isothermal evaporation. If, in the binary system, Fig. 2, we wish to obtain hydrate H, the procedure would be to prepare an unsaturated solution such as F and cool it to point O in order to crystallise the hydrate, leaving a mother-liquor B, or to subject the unsaturated solution i. to isothermal evaporation when it will deposit the hydrate as soon as the composition has moved to

the right of E. In the case under consideration, it would be unwise to attempt to prepare H by cooling solution J because this would pass through the saturated area of anhydrous B before entering that of the hydrate, and hence B would first precipitate and then decompose with the formation of H. This might leave the hydrate contaminated with a little of solid B unless a very prolonged stirring of the complex

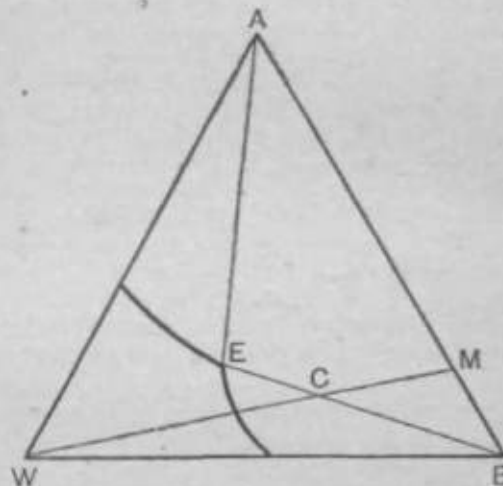

FIG. 32.

were made. Having once obtained the hydrate and separated the corresponding mother-liquor, more water and solid B can be dissolved to obtain a further crop of the wanted hydrate. This operation can be repeated until accumulation of soluble impurities (if any) or loss of adhering mother-liquor with the crystals makes it necessary to correct the composition of the complex. Figs. 43-46 show actual binary

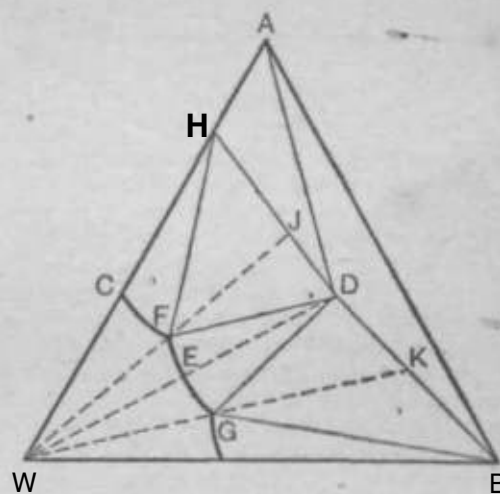

FIG. 33.

systems exhibiting characteristics such as discussed above and their use in the preparation of anhydrous or hydrated solid phases will be evident.

In three-component systems, e.g., Fig. 33, in order to obtain compound D it is necessary to prepare a complex, the composition of which corresponds to a point within the area DVQ. It is desirable, if possible, to dissolve all the con-

stituents. If this can be done at a higher temperature, then on cooling to the temperature of the isotherm, the compound D will be precipitated and can be separated. As an alternative, isothermal evaporation, *e.g.*, of a solution on the line WE, can again be employed. In this case also, the mother-liquor may be used to dissolve fresh raw materials and produce further amounts of D until impurities or adhering liquor on crystals make this impracticable. In Fig. 33, the compound D dissolve congruently, whilst in Fig. 34 it is incongruent. In the latter case, care would have to be taken when considering isothermal evaporation not to choose a starting liquor which could deposit B before precipitating D; this case is analogous to the one previously mentioned for a binary system. An example of a congruent double salt exists in the system  $\text{Na}_2\text{SO}_4\text{-(NH}_4\text{)}_2\text{SO}_4\text{-H}_2\text{O}$  at  $25^\circ\text{C}$ . (Fig. 47), and an incongruent compound, sodium Bisquicarbonate, is to be found in the system  $\text{Na}_2\text{CO}_3\text{-NaHCO}_3\text{-H}_2\text{O}$  (Fig. 48).

Purification of Salts by Crystallisation.—This has much in common with the prepar-

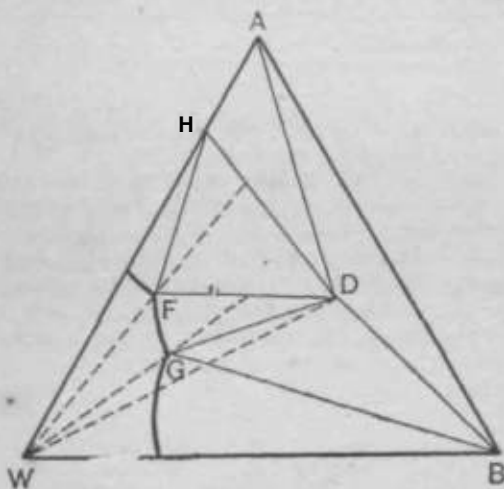

Fig. 34.

tion of compounds which has been discussed in the last section, but it may often be simpler since it may merely be a question of recrystallising one of the system components, *e.g.*, an anhydrous salt. The same general principles will apply, *i.e.*, the salt must be crystallised under conditions which are represented by the appropriate saturation area on the diagram. The necessity for recrystallisation implies the presence of impurities which have to be removed—insoluble impurities will need to be filtered off before recrystallisation and soluble impurities may be present to a sufficient extent to alter the solubility relations. Thus, in recrystallising a simple salt from an aqueous solution, soluble impurities can make the system into one of three components instead of two. Similarly, the recrystallisation of a ternary compound may involve four-component solubility data. It is likely that any first operation in a recrystallisation series can be carried out without soluble impurities interfering seriously, but the re-use of mother-liquor to dissolve raw materials may eventually make it necessary to consider data

relating to a system which also contains the soluble impurity as a component. The subject of accumulation of impurities will be discussed more fully in a later section.

The Separation of Salt Mixtures.—The separation of solid mixtures into their constituents is a problem which presents itself from time to time. In some cases the separation can be accomplished by purely mechanical means which make use of the difference between the physical properties of the solids. Such a method may include sieving, flotation, magnetic separation, elutriation, etc. Problems of the type encountered in mining engineering can be often solved by such methods.

It frequently happens, however, that in the chemical industry the component parts of a salts deposit need separating or the product of a crystallisation requires to be purified.

In the case of a separation process based on phase equilibrium data, two components—often salts with a common ion—must first be considered. The equilibrium diagram will be one of the types illustrated in Figs. 1-8, or in certain cases a combination of more than one of those types. The diagrams show the influence of temperature on the solid and liquid states. If the system under consideration exhibits easily attainable "melting" points, a complete or partial liquefaction of the mixture can be carried out. In the latter case, the system may contain a liquid and an excess of a pure solid. Such a case is shown in Fig. 31, where the initial mixture is assumed to have the composition represented by the vertical line *ac*. It will be seen that the best that can be done in this type of separation is to cool to the eutectic temperature, when the mixture will be separated into the eutectic solution and the excess of whichever solid is present. Reference to Fig. 3 will show that the existence of compounds between the components may make a limited separation of the type under consideration less attractive.

With Figs. 4-8 (solid solutions), the separation of excess solid by partial fusion becomes still less effective and usually almost impracticable.

In order to get a good separation by using phase-equilibrium data it is customary to add a third component which is liquid over a reasonable range of temperatures and in which each solid component is soluble. The third component chosen is usually water, but of course it may be some other liquid. The equilibrium relations of ternary systems thus become involved. Reference to the simplest possible case (Fig. 32) will show that the addition of water to a mixture *M* may give either (a) solution and solid A and solid B; (b) solution and solid B, or (c) unsaturated solution. The best separation at a single temperature will be obtained if the ratio of water and *M* is adjusted to give an aqueous mixture represented by *c*, which will yield the maximum amount of B and leave the isothermal invariant solution *ft*. This partial separation is little or no improvement on the fusion method already referred to. If, however, it is found that at another temperature the character of the isotherm changes as in Fig. 35, then the foundation of a two-temperature separation exists. The criterion for this type of

separation is that a change of temperature produces a substantial change in the ratio of dissolved salts (A and B) in the solution saturated with both of them. This can be illustrated in a diagram such as Fig. 36, which shows the proportion of salts plotted against temperature. The basic composition of the principal solutions are shown on the line AB of Fig. 35, and the lettering

this complex *ha* stirred at the higher temperature, then a quantity of B is left as a solid phase in equilibrium with liquor B of the complex in position with which the process started. The series of operations just described can, theoretically, be repeated indefinitely, though in practice there are certain limitations which will be discussed later. It will be noticed that these

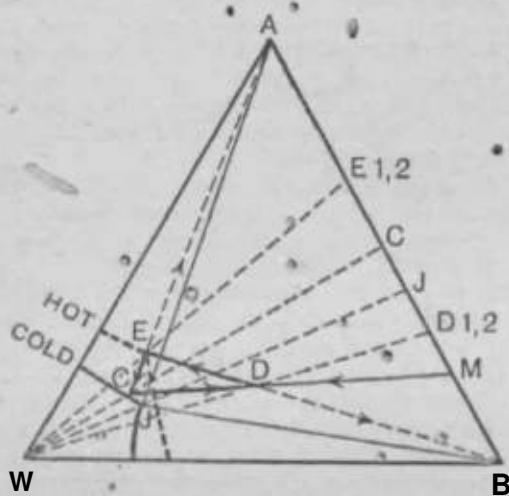

FIG. 35.

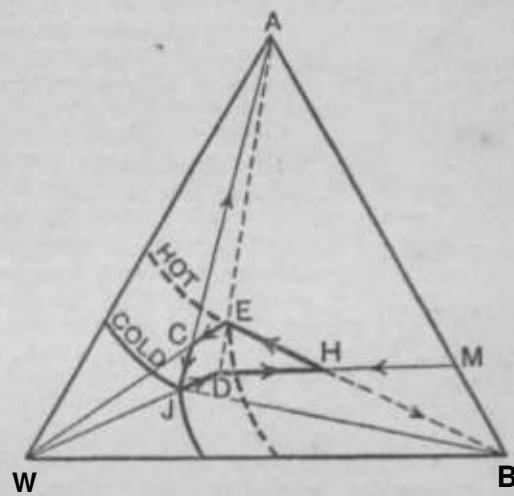

FIG. 37.

is similar in Fig. 3G. This will enable the relationship between the two diagrams to be seen.

In Fig. 35, the cold isotherm is shown by full lines and the hot one by broken lines; the isothermal invariant points E and J contain the solid components A and B in differing proportions. When these conditions apply, the data

operations have not involved any change in the water content of the solutions.

Instead of the simple case illustrated in Fig. 35, a somewhat different one may occur, as in Fig. 37, where point B lies outside the complex space for solid A and its saturated solutions. When this happens it is necessary to add water to dilute the solution B to point a which lies on the line AJ—it can then be safely

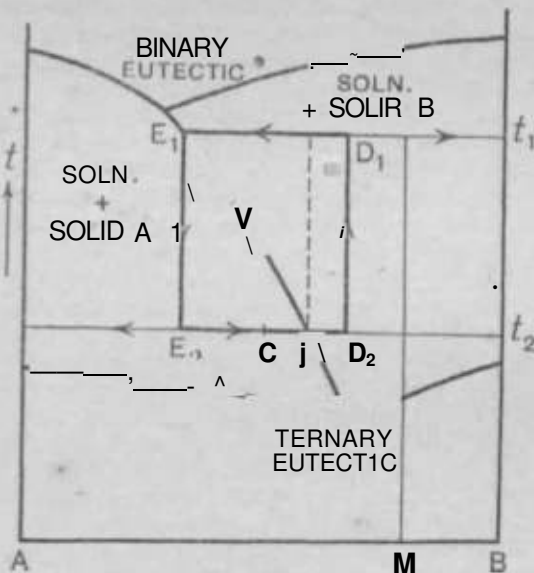

FIG. 36.

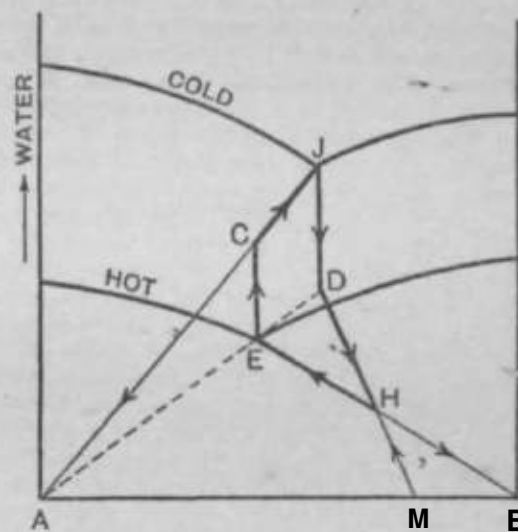

FIG. 38.

can be used to work out the separation of a solid mixture such as M into its constituent amounts of A and B. It will be seen that the fixed point E lies within the complex area for A at the lower temperature so that on cooling solution M, solid A will be deposited leaving a mother-liquor J. If to this latter liquor mixture M is added in such quantity that the complex reaches point D and

cooled to the lower temperature and will deposit solid A only, instead of a mixture of A and B. Having obtained the cold mother-liquor J, it is now necessary to evaporate the added water and reach *i*, which lies on an extension of the straight line AB. The evaporated liquor D is now treated with sufficient of the mixture H to reach point H on the line EB. On stirring the complex *u* in the hot, it yields solid B and liquor



with which the separation started. Thus, in Fig. 37, the five-sided separation cycle  $ECJDE$  occurs instead of the triangular one  $ECDE$  of Fig. 35. It is interesting to use the method of Fig. 11 and re-plot Fig. 37 on a diagram in which the horizontal line represents the pure solids and their mixtures, and water is plotted vertically. This has been done in Fig. 38 and since the points have been similarly lettered no further explanation is needed. This alternative method of representation is important because it forms a link between separation in a ternary system and that in a quaternary system, which will be considered shortly.

To sum up the conditions necessary for the separation of a binary salts mixture (A-B), it is essential that the ratio of A to B in the fixed points E and J should vary with temperature. If no such variation occurs, no complete separation of A and B can be made from the given mixture M, although it may be possible to separate a portion of the component which, at any temperature, is in excess of the constant ratio A/B of the dissolved salts.

**Preparation of Salts by Double Decomposition.**—This involves the "reciprocal salt pair" type of four-component system, the simplest case being shown in Fig. 39 in which there are plotted projections of two isotherms for the equilibria involved in the reaction  $AY + BX \rightleftharpoons AX + BY$ . The representation follows the principles which have already been outlined (p. 442a) and the projections show only the ionic ratios A/B and X/Y in the salts present. The water content, which is normally plotted vertically, in space, has been omitted. The case chosen is one of congruent solubility with respect to AX and BY. A space model showing full details of this system at the two temperatures concerned could be divided by a vertical plane AX-BY-H<sub>2</sub>O into two distinct portions. The plane itself forms what is frequently described as a pseudo-ternary system. The representation of such a plane viewed in direction of arrow n is given in Fig. 40 and it will be noted that this is very similar in character to the ternary diagram, Fig. 38; the only essential difference is that the mixture M is actually a point represented at the intersection of the diagonals in the square of Fig. 39. Since the plotting is in equivalents or gram-molecules, point H may represent either equivalents of the incompatible AY and BX, or of the compatibles AX and BY. Returning now to the pseudo-ternary system, Fig. 40, the mixture M is added to the process in the form of the incompatible and when equilibrium has been established it behaves as an equivalent mixture of the compatibles which are the products of the double decomposition. Thus, the full scheme is to start with the cold mother-liquor, J, evaporate water to point P, add sufficient of the incompatible equivalent mixture to reach point N, then stir this to equilibrium in the hot to produce a complex containing solid AX and the mother-liquor

K. AX is filtered off and liquor K is diluted to point L, and, on cooling this diluted solution to the lower temperature, BY is precipitated and solution J of the initial composition is again obtained. A cold mother-liquor such as J is

often described as the "nucleus liquor" and theoretically the series of operations which have been described can be repeated to produce AX and BY from an equivalent mixture of AY and BX, and to keep mother-liquors J and K constant in composition and quantity. This is an

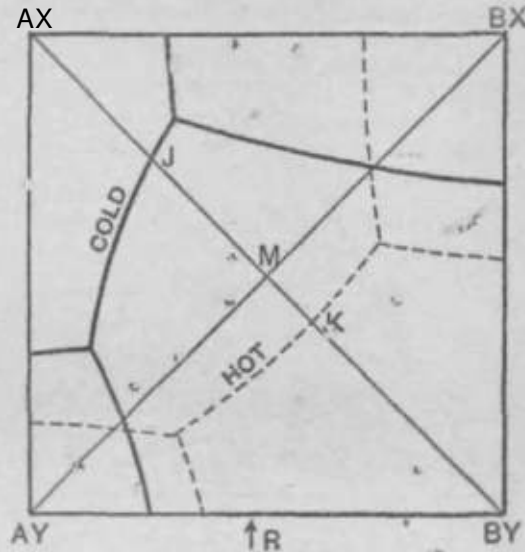

FIG. 39.

ideal scheme which requires some correction in practice as will be discussed later.

In Figs. 39 and 40 a simple case has been considered where the process solution can be expressed in terms of AX, BY, and H<sub>2</sub>O. The cycle is, however, not limited to such solutions, since a satisfactory separation can be made with solutions which also contain either the salt AY or

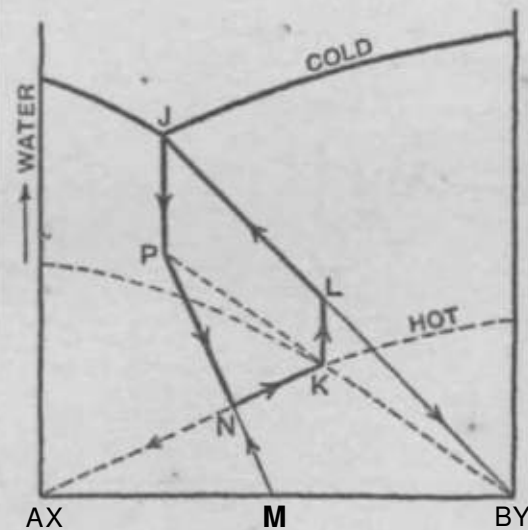

FIG. 40.

the salt BX, provided that the concentration of either of these salts does not exceed saturation value at any stage in the process. A system such as that represented in Fig. 41 exhibits incongruence and separations must always be made in solutions containing AY as well as AX and BY.

It will be evident that in cases where, owing

to incongruence or other consideration, the cycle solution contains a third salt as well as the compatible pair, it is no longer possible to represent the operations on a vertical diagonal plane. In Fig. 41 it is possible to follow some of the operations involved in the double decomposition. Since these no longer project on the AX—BY diagonal as with Fig. 39. If the process begins

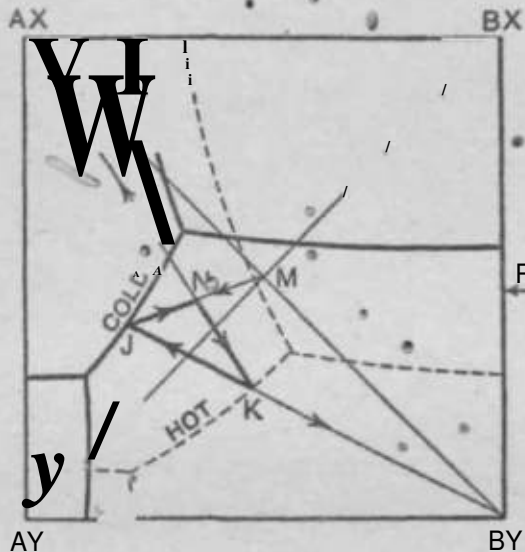

FIG. 41.

with the hot solution K, it is evident that solid BY and a cold mother-liquor J can be obtained from it. Usually it will be necessary to dilute K before cooling it, but this operation can only be shown in a horizontal projection such as Fig. 42, which shows that it is necessary to add sufficient water to reach point L in order to arrive

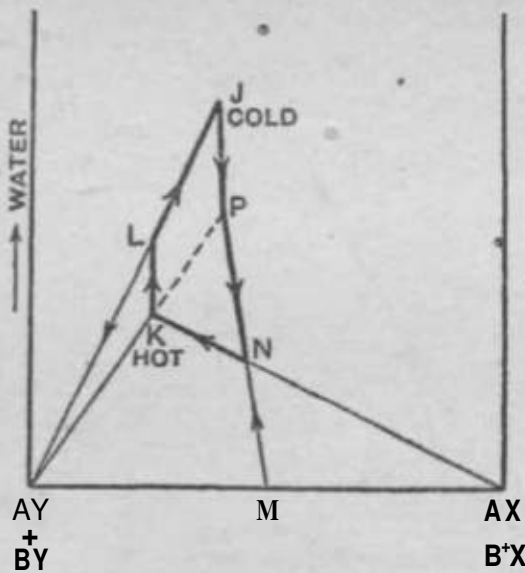

FIG. 42.

at liquor J on cooling. The solid BY which is present is then separated and the dilution water is evaporated to reach point p—to this evaporated liquor the raw materials M are added in sufficient amount to reach K. On stirring this to equilibrium in the hot, solution E is reformed and solid AX which is now present can be

filtered off—thus completing the series of operations. It will be understood that the order in which water is evaporated and raw materials added can be interchanged if there is any obvious advantage to be obtained by doing so. A variation which is sometimes made in double decom-

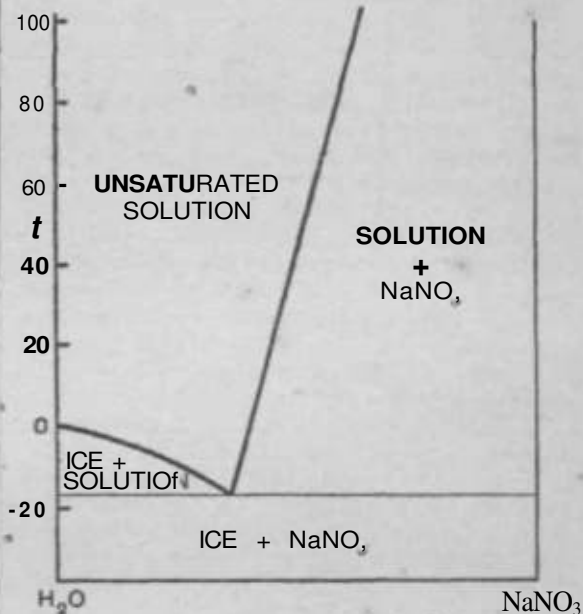

FIG. 43.

position is to add the raw materials separately at different stages of the process.

It will be realised that in especially favourable cases it may be unnecessary to include the operations of dilution and evaporation in

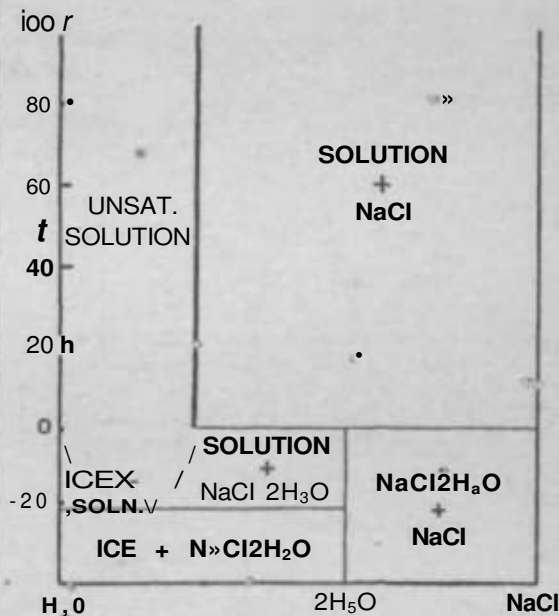

FIG. 44.

four-component systems such as those discussed.

EXAMPLES OF CYCLIC SEPARATION.

The application of phase equilibria to the separation of salt mixtures has been briefly

described by A. Findlay and A. N. Campbell, "The Phase Rule and its Applications," 8th ed., Longmans, 1933. In this book the authors derived much of their subject-matter from the paper of F.A. Freeth in a Leiden Thesis, 1024, and

$\text{Na}_2\text{SO}_4$  and  $\text{NH}_4\text{ClO}_4$ , two salts which, although possessing no common ion, can, however, co-exist in aqueous solutions at  $25^\circ\text{C}$  and  $\text{K}^\circ\text{C}$ . Freeth showed how the data for  $\text{Na}_2\text{SO}_4\text{-NH}_4\text{ClO}_4\text{-H}_2\text{O}$  could be used in a complete and quantitative separation of a 50/50% weight mixture of the two salts in question. The separation in its ideal state involves neither

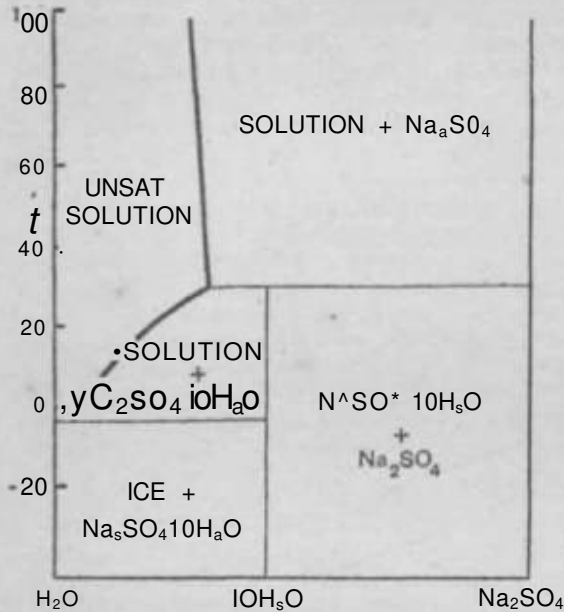

Pic. 45.

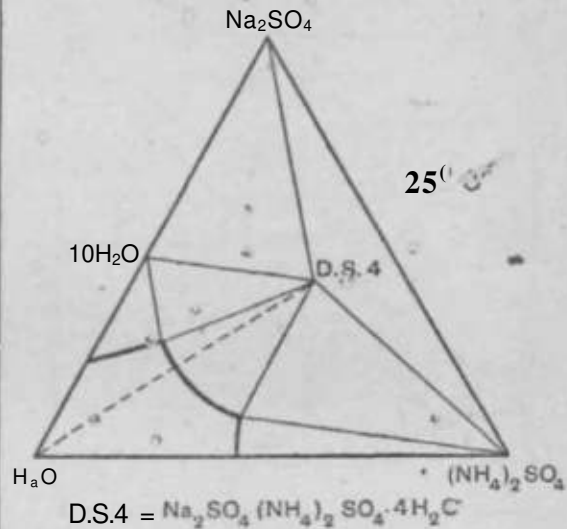

FIG. 47.

Rec. trav. chim. 1924, 43, 475. Preeth presented equilibrium data for the quaternary system

$\text{NaClO}_4\text{-NH}_4\text{ClO}_4\text{-Na}_2\text{SO}_4\text{-(NH}_4)_2\text{SO}_4\text{-H}_2\text{O}$  at  $25^\circ$  and  $60^\circ\text{C}$ , and included the subsidiary

dilution nor evaporation. Referring to Fig. 49, the cycle involves the cooling of  $60^\circ$  liquor o to  $25^\circ\text{C}$ . to yield pure  $\text{NH}_4\text{ClO}_4$  and a mother-liquor A; the solid is separated and mixture M is added to give the magma B, which at  $60^\circ\text{C}$ . separates pure  $\text{Na}_2\text{SO}_4$  and "regenerates the starting liquor O. In order to begin a cycle of this kind, it will be necessary to carry out a preliminary operation such as digesting some of

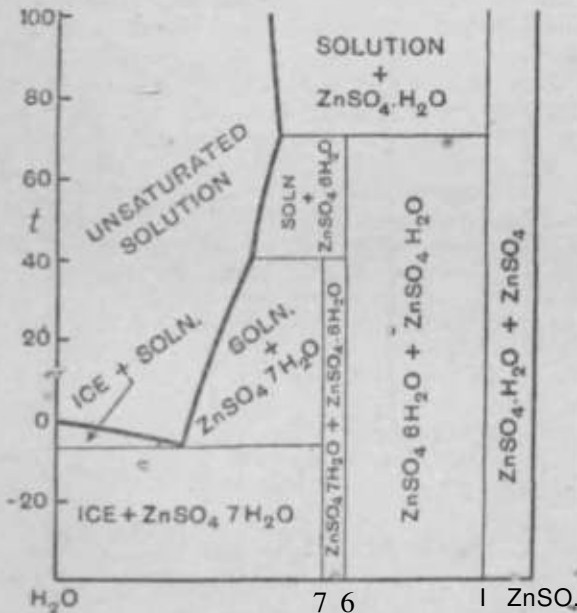

FIG. 46.

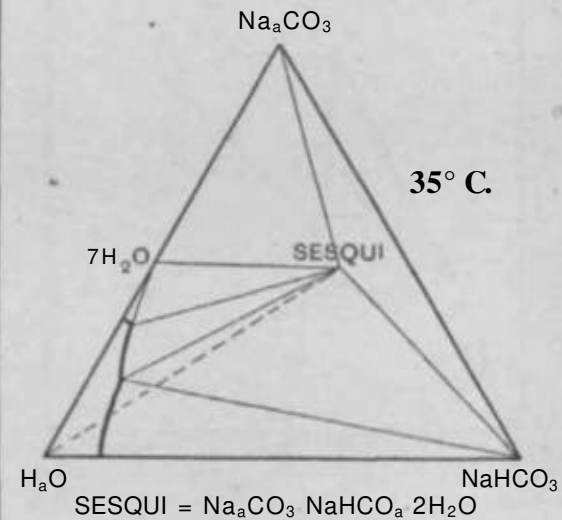

FIG. 48.

ternary systems containing water and certain binary salt groups from the above list; he also gave quantitative diagrams for separations based on the principles which have been discussed. Examples from Preeth's paper are given.

Fig. 49 relates to a cyclic separation of

the 50/50% mixture with water at  $60^\circ\text{C}$ . to yield a magma which represents 60% solution o and an excess of  $\text{Na}_2\text{SO}_4$ , which is separated. The diagrammatic representation of the operation will be evident from the lettering and arrows shown on the separation figures, which is an



irregular triangle within the main system equilateral triangle. The presentation of the quantitative aspect of this separation will be referred to later.

It should be made clear that care has to be exercised in discussing the separation of a "pseudo-binary" mixture such as

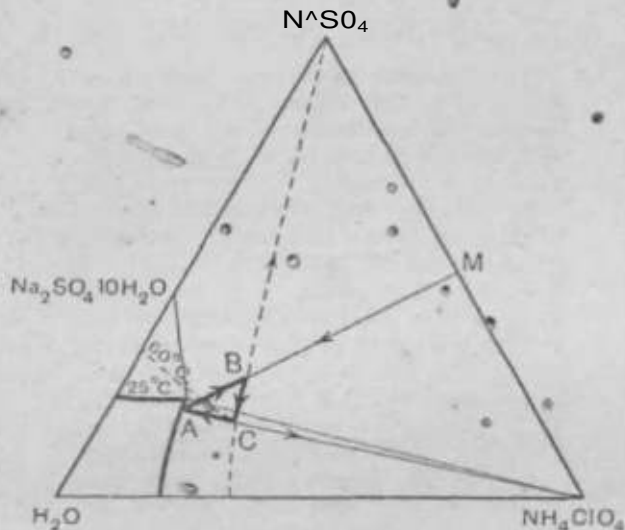
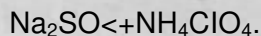

Fig. 49.

Before dealing with such a mixture it is essential to confirm that no double decomposition can occur in aqueous solutions in the temperature range available for separation treatment; usually this would lie between 0° and 100°C. For a true binary mixture which has a common ion, a good example of a cyclic non-dilution process can be arranged for a KCl+NaCl mixture.

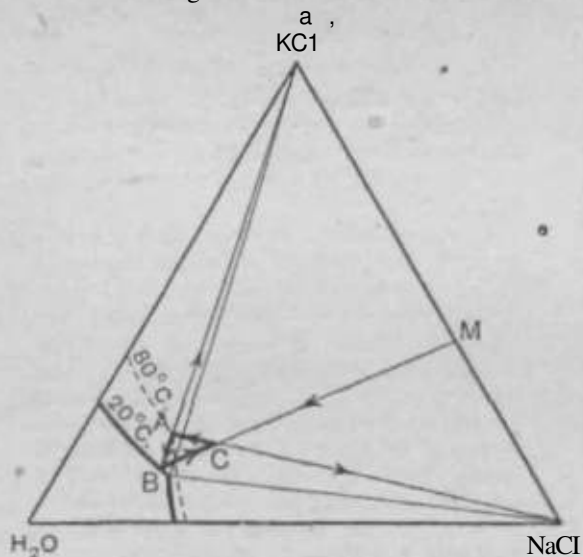

FIG. 50.

Blasdale (J. Ind. Eng. Chem. 1918, 10, 347) described the principles without presenting a cyclic quantitative scheme. The separation can, however, easily be constructed in the phase-equilibria manner by using data given by Blasdale and others for the system KCl-NaCl-H<sub>2</sub>O.

This has been done in Fig. 60 for a 40% KCl/60% NaCl mixture, employing the temperatures of 80° and 20° for the separation of NaCl and KCl, respectively.

Reverting to the paper of Freeth, a good example is given of a phase-rule separation of a binary mixture where dilution and evaporation is needed in the "liquo-ionic" pair of salts, NH<sub>4</sub>ClO<sub>4</sub> + (NH<sub>4</sub>)<sub>2</sub>SO<sub>4</sub>. This is illustrated in

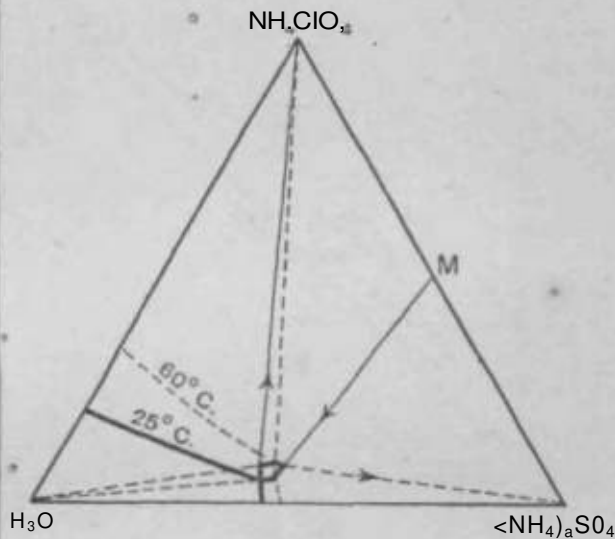

Fig. 51.

Fig. 51, where the separation figure is now in the form of an irregular pentagon instead of an inner triangle as in Figs. 49 and 50.

Another example involving a binary common ion mixture with dilution and evaporation included, is outlined in the patent of Freeth and Cocksedge, B.P. 124513, 1919. This deals with

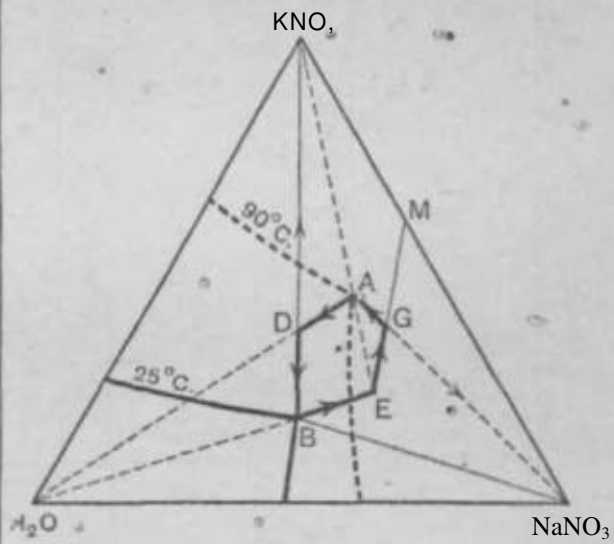

Fig. 52.

the recovery of KNO<sub>3</sub> from commercial sodium nitrate. Though no quantitative examples are given in the patent, it can readily be illustrated from published data relating to the system KNO<sub>3</sub>-NaNO<sub>3</sub>-H<sub>2</sub>O, as has been done by Liaid in J.S.C.1.1926,45, 315T, and by Purdon and Slater (*op. cit.*). A separation diagram,

employing the principle claimed by the authors, has been given in Fig. 52, using 90°C. as the separation temperature of  $\text{NaNO}_3$  and 25°C. for  $\text{KNO}_3$ .

Phase-equilibria separations which have been

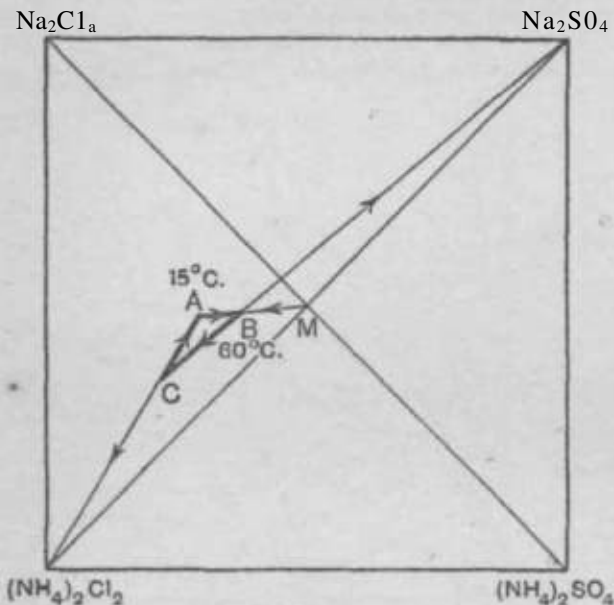

Fig. 63.

represented in Figs. 49-52 are not limited to the mixtures used as examples. Any proportion of the two solids can be dealt with on the same principles, the effect being to modify the size and

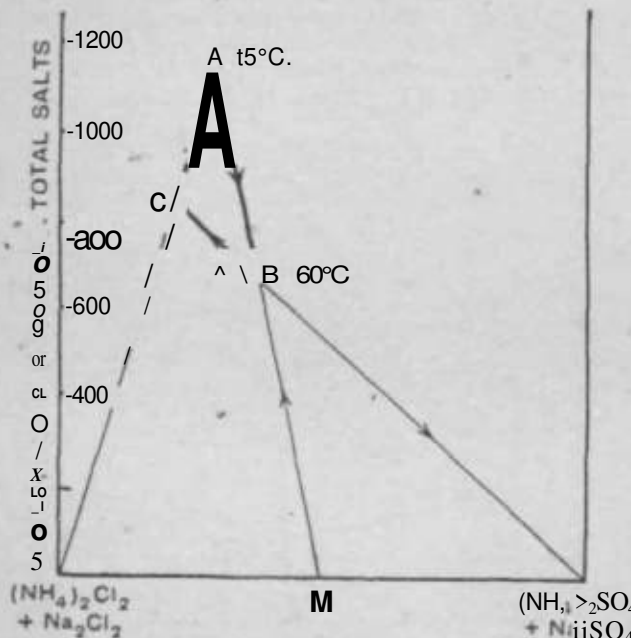

Fig. 64\*.

shape of the inner separation triangle or pentagon.

EXAMPLES INVOLVING DOUBLE DECOMPOSITION,

Actual examples of cyclic phase-rule processes involving double decomposition include that involved in the sulphate-perchlorate systems of

Freeth (*loc.*). The solubility results show that in the reaction:

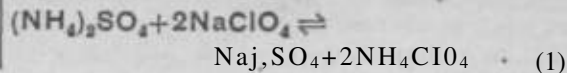

the compatible salts are:



and the incompatibles are:

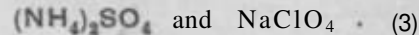

In considering a process based on reaction (1), the incompatible salts (3) become the reactants or raw materials, and the compatible salts (2) are the results or products.

If, in Fig. 49, the 50/50% weight mixture is replaced by an equivalent mixture of  $\text{Na}_2\text{SO}_4$  and  $\text{NH}_4\text{ClO}_4$ , the separation is unaffected in principle. It is also possible to substitute for the equivalent mixture of  $\text{Na}_2\text{SO}_4 + \text{NH}_4\text{ClO}_4$  equivalents of  $(\text{NH}_4)_2\text{SO}_4$  and  $\text{NaClO}_4$  and feed these as raw materials to a cycle similar to Fig. 49, obtaining the products  $\text{Na}_2\text{SO}_4$  and  $\text{NH}_4\text{ClO}_4$  at 60° and 25°, respectively.

In Fig. 23, Freeth's data have been plotted to show the form of the two isotherms. In Fig. 24 the vertical diagonal plane has been projected in the direction of the arrow in Fig. 23. In this projection are shown the operations involved in separating equivalents of  $\text{NH}_4\text{ClO}_4$  and  $\text{Na}_2\text{SO}_4$  from a process receiving equivalents of  $(\text{NH}_4)_2\text{SO}_4$  and  $\text{NaClO}_4$ .

Another double decomposition treated in this manner is described by Freeth and Cocksedge in B.P. 26263, 1909, and 86, 1910. This deals with the reaction:

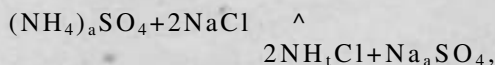

again a scheme where no dilution or evaporation is needed in the ideal state. The separation temperatures in this case are 60°C. for  $\text{Na}_2\text{SO}_4$  and 15°C. for  $\text{NH}_4\text{Cl}$ .

An example from B.P. 86, 1910 has been given in Figs. 53 and 54, which show the cyclic process operations.

Separations in reciprocal salt-pair schemes where dilution is required, include the preparation of  $\text{KNO}_3$  and  $\text{NaCl}$  from  $\text{NaNO}_3$  and  $\text{KCl}$ . This well-known process can be put on a cyclic basis by using solubility data (W. Reinders, Z. anorg. Chem. 1915, 93, 203; M. A. Hatnid, J.S.C.I. 1026, 45, 315).

Probably the best example of the industrial application of phase-equilibria methods to a double decomposition is the reaction between  $(\text{NH}_4)_2\text{SO}_4$  and  $\text{NaNO}_3$  to produce  $\text{NH}_4\text{NO}_3$  and  $\text{Na}_2\text{SO}_4$ . Freeth and Cocksedge (B.P. 12401, 1915; Chem. Met. Eng. 1919, 20, 320, 401) developed this process for the large-scale production of  $\text{NH}_4\text{NO}_3$  in Britain and America during the First World War. The presence of a number of double salts added to the difficulties which were encountered

in placing fchffl process on a firm manufacturing basis. This process separated  $\text{Na}_2\text{SO}_4$  in the hot ( $60^\circ\text{C}$ ) and  $\text{NH}_4\text{NO}_3$  was crystallised after diluting the  $\text{Na}_2\text{SO}_4$  mother-liquor and cooling to an average temperature of  $20^\circ\text{C}$ . (see Figs. 65 and 56).

An interesting improvement based on phase equilibria was subsequently claimed by Freeth and Cocksedge<sup>^</sup> B.P. 149095, 1920. This involved the reduction of the  $\text{Na}_2\text{SO}_4$  content of the  $\text{NH}_4\text{NO}_3$ ,  $9 \text{ NaNO}_3$ ,  $\text{Na}_2\text{SO}_4$  solution remaining from the double decomposition, by the addition of calcium sulphate to precipitate glauberite ( $\text{CaSO}_4 \cdot \text{Na}_2\text{SO}_4$ ), a compound which can exist in equilibrium with aqueous solutions which are unsaturated with  $\text{Na}_2\text{SO}_4$ . The reduction of the  $\text{Na}_2\text{SO}_4$  content of the process liquor enabled better yields of  $\text{NH}_4\text{NO}_3$  to be obtained.

Other examples include the preparation of calcium nitrate and sodium chloride from calcium chloride and sodium nitrate (J. G. Gilbert, B.P. 124780, 1916). In this case,  $\text{NaCl}$  is removed in the hot and  $\text{Ca}(\text{NO}_3)_2 \cdot \text{H}_2\text{O}$  crystallised after diluting and cooling.

A recent process developed by phase-equilibrium methods is that of Canadian Industries, Ltd., for the preparation of sodium sulphite and ammonium chloride from ammonia, sulphur dioxide, and sodium chloride (E. R. J. Cooke, Chem. Trade Journal, June 8th, 1945, p. 605; Canadian Chemistry and Process Industries, April, 1945, p. 221).

Among the more complex systems which have been studied in reference to "salt" formation is the notable series by J. H. van't Hoff and others in order to explain the formation of the oceanic salt deposits.

Another investigation is that of J. E. Teeple, "The Industrial Development of Searia Lake Brines," New York, 1929. In this monograph, Teeple describes the results of studies on many system combinations containing the ions  $\text{Na}^+$ ,  $\text{K}^+$ ,  $\text{Cl}^-$ ,  $\text{CO}_3^{2-}$ ,  $\text{HCO}_3^-$ ,  $\text{SO}_4^{2-}$ , and  $\text{BO}_3^{3-}$ . The principal aim of Teeple's work was the production of  $\text{KCl}$  and borax from the lake liquor containing all the ions referred to above.

In addition to publishing his solubility results and discussing them, Teeple reported their successful application to the manufacturing scale. He did not, however, discuss the process in detail, but merely referred to it in general terms.

Flow sheets (not quantitative) for the Searia Lake processes appear in Chem. Met. Eng., Oct. 1945, p. 134.

FLOW SHEETS FOR MATERIALS BALANCE.

It will be appreciated that an ideal separation scheme involves no wastage of salts or their solutions, since a "cold" mother-liquor is usually kept within the process and used to dissolve more "raw material" either partially or completely.

Reference has been made to the separation figure within an equilibrium diagram. This is bounded by lines which represent the change of solution or solid compositions during each operation. Since each individual movement of com\*

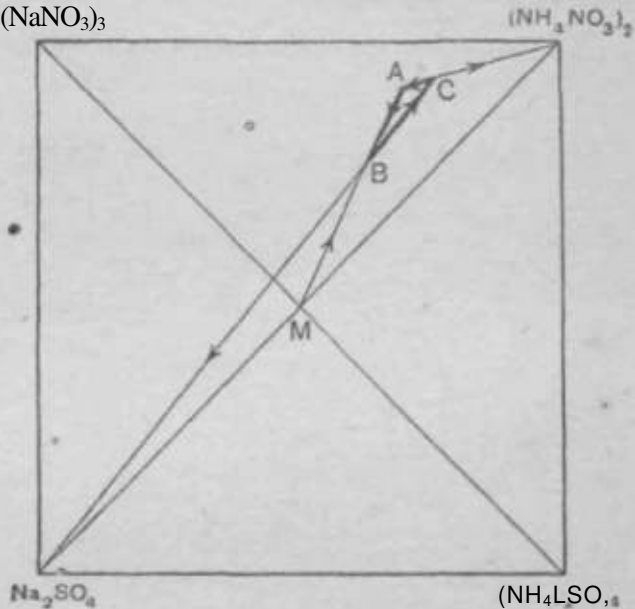

FIG. 55.

position depends on the amount of solids or water added, or removed at different points in the process, the size of the separation figure relative to that of the appropriate solid plus 0

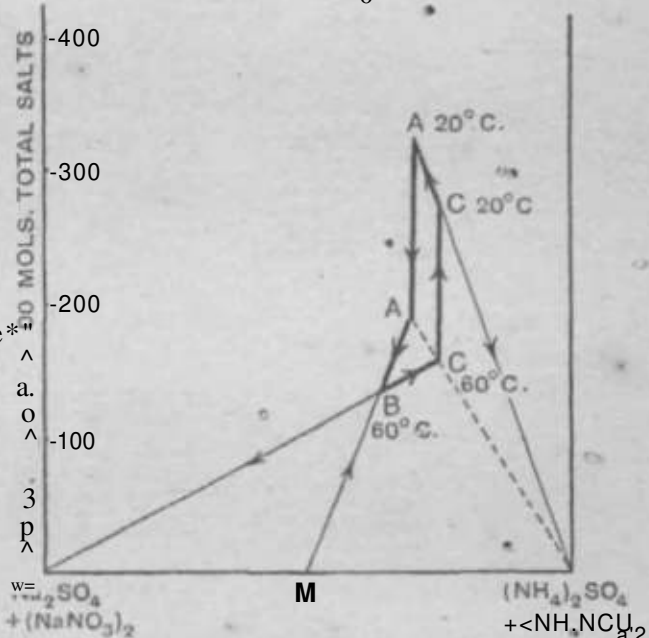

FIG: C8.

solution areas of the two isotherms, is an illustration of the efficiency from the standpoint of volume yields, and the amount of evaporation necessary per unit of the product. Some processes are chemically possible but the volume yields are too poor to make them economically attractive. Although it is difficult to generalise on this point, a yield may be considered satis-

factory if it is of the order 150-200 kg. of solid per cubic metre of liquor.

In the preceding discussions on the separation of salts from mixtures, and the products of decompositions, the various operations have been described with reference to diagrams. It

will be clear that theoretically 'the mother-liquors from the separated products will remain constant in composition and quantity, and in these ideal cases can continue to be returned to the process. Schemes of this type are usually called cyclic processes. It is well to note two

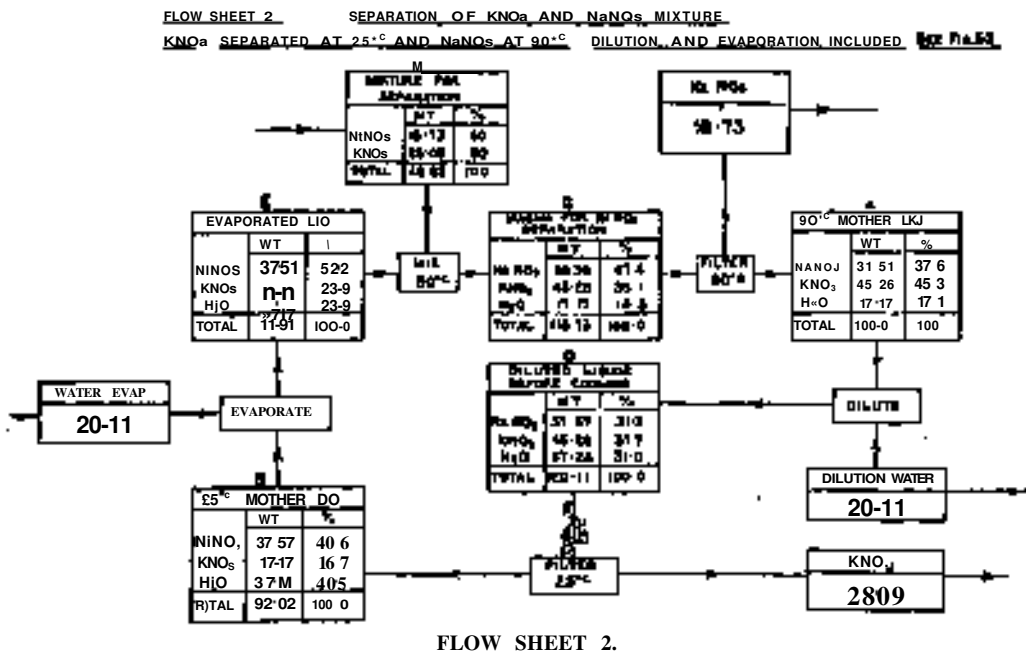
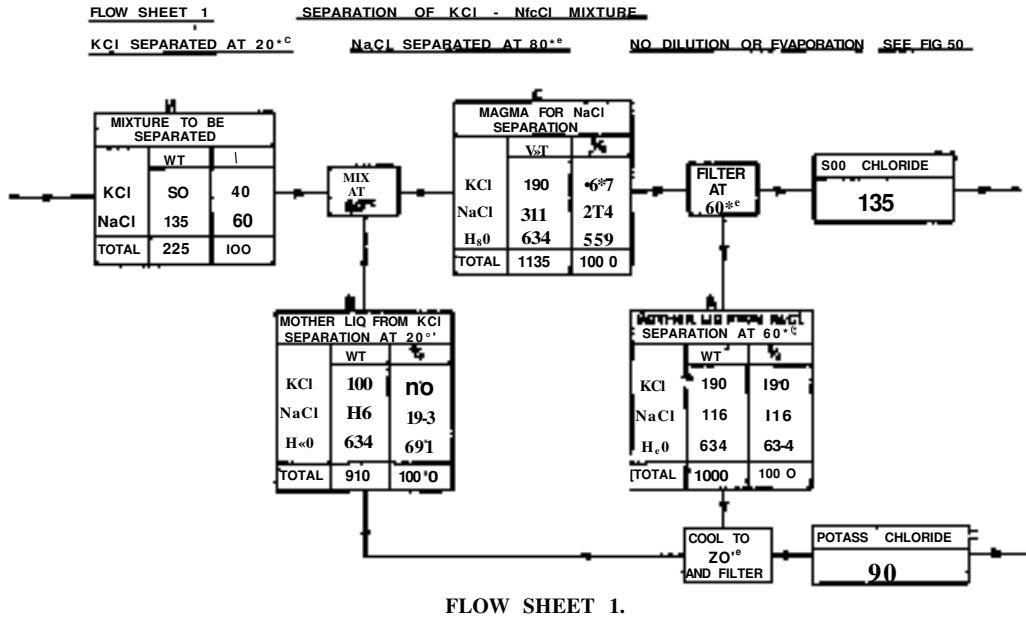

main characteristics of processes of this type which may seem rather obvious but which are sometimes overlooked:

1. The total stocks of liquor in a process working at a constant output will remain steady.
2. Everything which is introduced into the process as raw material will also ultimately appear as an equal weight of product or by-product.

The separation of salts in systems of three or four components can often with advantage be set out in "flow sheets." These form an excellent supplement to the phase-equilibrium separation diagram concerned, and they also enable exact material balances to be worked out for the schemes under consideration, and enable one to observe the two main principles which underlie the cyclic processes. The use of a flow sheet can best be followed by actual examples illustrating the separations which have been shown diagram-

matically. *the* ideal flow sheets, NOB. 1-4, showing the material balances, have been labelled Similarly to the corresponding diagrams in order to make cross-reference easy.

It will be understood that the flow sheets so far

considered relate to ideal processes with perfect material balances—these do not, of course, exist in practice and some of the disturbing factors will be considered later. Ideal flow sheets do, however, enable comparisons to be made

FLOW SHEET 3. DOUBLE DECOMPOSITION OF  $(NH_4)_2SO_4$  AND  $Na_2CO_3$  TO YIELD  $NH_4Cl$  AND  $Na_2SO_4$  AT 15°C AND 60°C. NO DILUTION OR EVAPORATION. SEE FIG. 53 A wd 54.

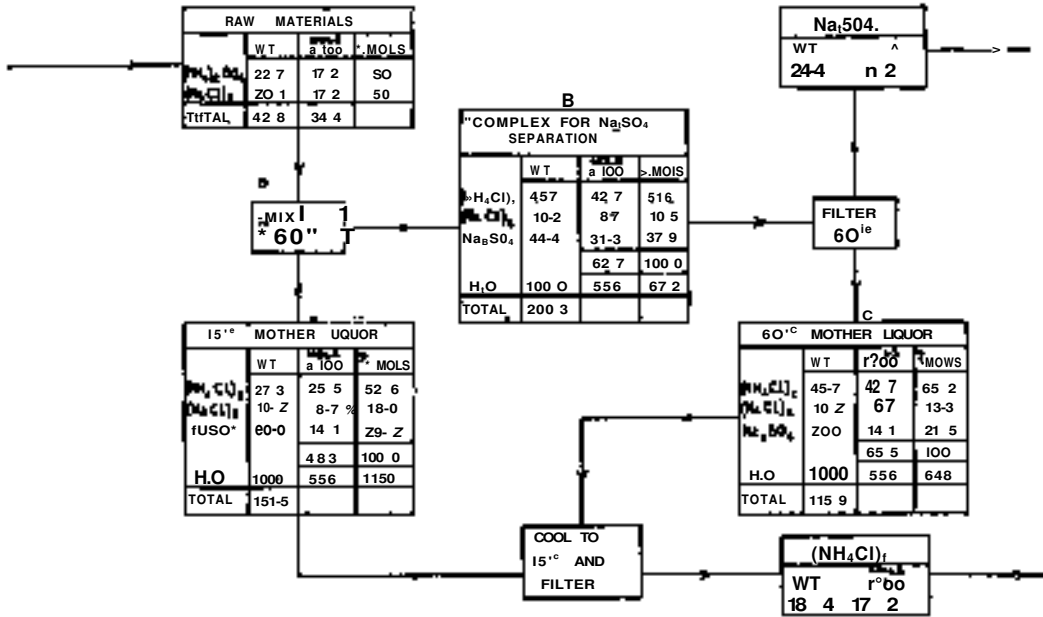

FLOW SHEET 3.

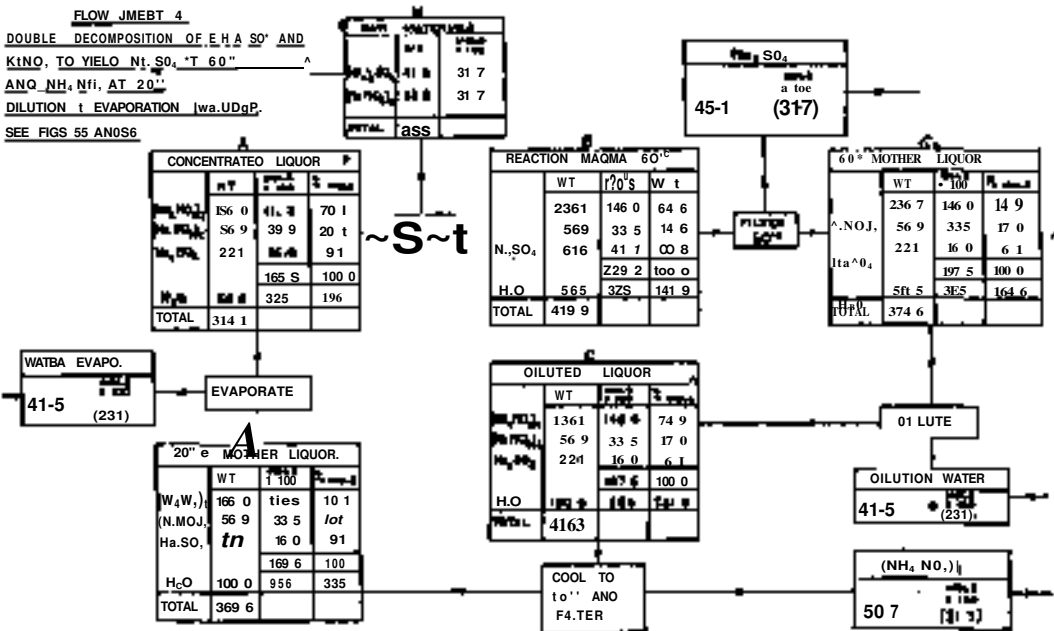

FLOW SHEET 4.

between different schemes, and they form the basis for flow sheets which approach more nearly to manufacturing conditions, where allowance has to be made for the influence of a number of other factors, including the time taken to reach equilibrium conditions.

FLOW SHEETS FOR MANUFACTURING CONDITIONS.

The variations in the ideal cycle, which are necessary under actual manufacturing conditions are due to a number of disturbing factors. In the following paragraphs the influences which

have to be reckoned with in a working process are discussed.

1. *The Need for a Safety Margin with respect to Unwanted Constituents.*—In order to ensure maximum volume yields in an ideal cyclic process it is usual to choose as mother-liquors at least one solution which is saturated with two or possibly three salts, but the extra salts should not be present in excess, otherwise they will contaminate one of the products. In order to prevent the inevitable plant fluctuations from causing an appearance of unwanted solids with the products, some or all of the following modifications may be made:

- (a) Less raw materials may be introduced in each cycle giving reduced yields of products.
- (b) The mixture before the "hot" separation may be super-heated beyond its normal temperature.
- (c) Two-stage counter current working can be employed to obviate the risk of unreacted raw material remaining with the product.
- (d) In order to prevent impurities appearing on cooling, this operation may be stopped before the lower temperature limit is reached, or a little dilution and subsequent evaporation can be introduced.

2. *Correction for Mother-liquor adhering to Products.*—In an ideal process it is assumed that the products are completely separated from the corresponding mother-liquor. In practice this is impossible, for a filtered product may retain adhering mother-liquor equal to 20-40% of its weight, while a centrifuged solid may contain 3-10% of adhering liquor. If impure products are satisfactory the only correction needed is the addition of sufficient components to replace the lost liquor. In general, however, the adhering liquor must be washed from the moist solids; the corrections then depend on the method of disposal of washings. If these can be wasted, it is again only a question of replacing lost liquor. If, as happens in most cases, the washings contain a component which must be recovered, it is necessary to reintroduce the washings at some suitable place or places in the cycle, then to evaporate in order to restore the water balance. It will be realised that correction has also to be introduced for the loss of yield due to dissolving a small proportion of the products by the wash water.

3. *Method of Disposal of Washings.*—If it is assumed that a product containing adhering mother-liquor has been washed with water, it is evident that the composition of the resulting wash liquor can itself be expressed in terms of dissolved product+mother-liquor+ excess  $H_2O$ . If the excess  $H_2O$  is evaporated and the mixture brought again to the separation temperature, a mixture of solid+mother-liquor results which can be returned to the magma for the main separation. Hence the ideal method for the disposal of washings which have to be returned to the process, is to have two evaporators which remove the excess water from the product and by-product washings, respectively, and to return

the evaporated complex to the corresponding magma before fagalling. If, for economic or other reasons, the washings are mixed and fed to one evaporator, some correction to the cycle becomes necessary in order to keep the products pure.

It is not suggested that any rigid method for the disposal of washings should be followed; variations can be introduced so long as they do not involve the contamination of the products. The first washings are mainly mother-liquor and would contain very little dissolved product.

4. *Impurities in Raw Materials.*—These may be either soluble or insoluble in the process liquors. In the latter case all the insoluble matter will appear with the first product obtained after the introduction of raw materials, unless some provision can be made for filter pressing before the hot-separation. • \*

The influence of soluble impurities introduced with the raw materials depends on their nature. If the impurities are readily soluble in the plant liquors, they will accumulate and some time may elapse before they appear in the product, but whether extremely soluble or only sparingly so, they will sooner or later appear in one or both products, because a balance must eventually be established between impurities entering and those leaving the cycle. This state of affairs could occur in one of two ways: (a) the mother-liquor of one or both products could become saturated with the impurity and cause the latter to be precipitated with the products, or (b) with a very soluble impurity and a process in which the products are not washed, or one in which the washings are rejected, it is possible that the adhering mother-liquor or the washings containing it would carry out of the process a quantity of impurity equal to that entering.

If pure products are required and if it is proposed to return wash liquors to the cycle, the elimination of soluble impurities can only be carried out by the regular or occasional rejection of a small amount of the plant liquor. The loss of dissolved salts entailed thereby will have to be made good by the addition of extra raw materials and an adjustment made to the amount of water to be evaporated.

It will be evident that soluble impurities may accumulate to an extent sufficient to modify the solubilities of the products, and therefore a working flow sheet will require some correction on this account. This is a point which can be best dealt with as analytical results of a series of cycles become available.

In certain favourable cases it may be possible to return the "rejected" liquor to the main process after subjecting it to a treatment which will remove a substantial amount of an accumulated impurity. Such treatment might simply be a precipitation, e.g., of sulphate by a barium salt or magnesium by calcium hydroxide. On the other hand it might involve a subsidiary fractional crystallisation based on solubility data.

5. *Metastable Equilibria.*—A feature of certain systems is their liability to produce metastable solutions, e.g., in the binary systems  $CaCl_2-H_2O$  and  $NaXO_3-H_2O$  it is possible, with care, to follow a hydrate solubility curve beyond its transition point, or to produce clear supersaturated

solutions whose compositions are intermediate between a stable and a metastable solubility curve. It is usual, in process working, to avoid such metastable solutions, though cases do occasionally occur where the metastability persists for a longer time than that required to perform some process operation, e.g., filtration to remove suspended matter. In such cases, the metastability can be put to good use. Extreme care is however necessary when deciding whether metastability can be permitted at any point in a process.

6. *Time Factor*.—The factor of which no account can be taken in calculating flow sheets is, as already stated, the time required to bring conditions to equilibrium or to carry out certain process operations. The effect of this in a working process is to make it essential to provide vessels, etc., of sufficient capacity to allow for the time factor and to store sufficient liquor to permit a process to be worked smoothly. This is essential even with batch working and becomes still more important with continuous working.

L. M. H.

## PHEILLANDRAL,

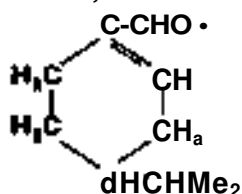

b.p. 75°/1-5 mm.,  $p^{20}$  0.9445,  $n_D$  1.4897,  $[a]_D$  +116.2°, -160.2°, *semicarbazone*, m.p. 204-205°, *oxime*, m.p. 87°, *phenylhydrazone*, m.p. 122-123°, *p-nitrophenylhydrazone*, m.p. 174-175°, 2:4-dinitrophenylhydrazon-e, m.p. 204°. *I*-Aldehyde occurs in water-fennel oil (from *Fanicidum vulgare*) and eucalyptus oils; *d*- in elemi and cinnamon oils.

J. L. S.

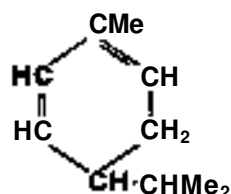
*a*-PHELLANDRENE,

b.p. 39°/4-5 mm.,  $p_f$  0.8324,  $n_f$  1.4724,  $[o]_D$  -177.4°, *a-nitrosite*, m.p. 121°,  $[a]_D$  +142.6°, *p-nitrosite*, m.p. 105-106°,  $[a]_D$  -160°. Occurs widely distributed in essential oils, more especially in eucalyptus oils.

J. L. S.

## 0-PHELLANDRENE,

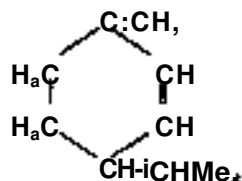

b.p. 171-172°, 57°/11 mm.,  $p^{TM}$  0.8520,  $n_D^{TM}$  1.4788,  $[a]_D$  +65.2°, -51.9°, *a-nitrosite*, m.p.

102-103°, *P-nitrosite*, m.p. 97-98°, *nitroa-chloride*, m.p. 106-107°. Occurs in many essential oils.

J. L. S.

PHEMITONE.  $\wedge$ -Methyl-S-phenyl-S-ethylbarbituric acid. "*Prominol*." Hypnotic and sedative: used in treatment of epilepsy. B.P. Add. III; B.P.C. Supp. III (w. SYNTHETIC DRUGS).

S. E.

PHENAOETIN. Aceto-*p*-phenetidine. Antipyretic and analgesic. B.P., B.P.C. (v. SYNTHETIC DRUGS).

S. E.

PHENACITE. A beryllium silicate mineral!  $Be_2SiO_4$ , containing BeO 45-6%. It usually occurs as crystals of rhombohedral form or as hexagonal prisms capped by a rhombohedron, and is so named on account of its having been mistaken for quartz. Phenacite has an imperfect prismatic cleavage and conchoidal fracture, whilst its great hardness (7-8) is of diagnostic value;  $p$  3.0. Colourless, white, sometimes pale red or bright yellow; lustre vitreous. It is a rare mineral, normally found in pegmatite veins associated with granite, and is often accompanied by topaz, beryl, and apatite. Phenacite is occasionally cut as a gemstone, and its high beryllium content makes it a valuable potential source of that metal.

D. W.

PHENANTHRENE. Although the presence in coal tar of a hydrocarbon isomeric with anthracene was recognised as long ago as 1872 (Fittig and Ostermayer, Ber. 1872, 5, 933; Annalen, 1873, 166, 361; Grabe, Ber. 1872, 5, 861, 968; Annalen, 1873, 167, 131) the chemistry of this compound, phenanthrene, and its derivatives, has been largely investigated during the last twenty years. This greatly increased interest in phenanthrene chemistry can be attributed to the discovery of a large number of naturally occurring compounds\* possessing a phenanthrene ring system in the molecule; these include the sterols, sex hormones, cardiac glycosides, bile acids, alkaloids of the morphine and apomorphine groups, etc. The need of identifying degradation products of these natural compounds and also of preparing suitable starting materials for attempted syntheses has given a great stimulus to the study of phenanthrene chemistry.

## ISOLATION AND PURIFICATION.

Phenanthrene is found in the anthracene-oil fraction of coal tar; it is more soluble in organic solvents than its isomer and this fact is utilised in its isolation. The crude anthracene is extracted with crude coal-tar solvent naphtha and that part of the solid which is readily soluble is *vised* for the production of phenanthrene. High boiling phenols are removed by extraction with caustic soda solution and acridine by means of sulphuric acid solution. Fusion with a mixture of sodium and potassium hydroxides frees the product from carbazole and diphenylene oxide. After distillation, that portion easily soluble in coal-tar naphtha is freed from any less soluble impurities by crystallisation from 95% alcohol (Clark, J. Ind. Eng. Chem. 1919, 11, 204; Wense,



Ber. 1886, 19, 761; Kraemer and Weissgerber, *ibid.* 1901, 34, 1665; G.P. 130679; B.P. 5047, 1901).

The separation of pure phenanthrene cannot be achieved by crystallisation alone. This process yields a material, m.p. ca. 102-115° (m.p. 101° when pure), which still contains appreciable amounts of anthracene, carbazole, and fluorene. With these substances phenanthrene forms mixed crystals with higher melting-points than that of the pure hydrocarbon (Pascal, Bull. Soc. chim. 1921, [iv], 29, 644).

In mixtures of anthracene and phenanthrene, the former is more easily oxidised. As phenanthrene can readily be separated from anthraquinone by extraction with a solvent, such as 85% alcohol, in which the quinone is only very slightly soluble, this constitutes a good and convenient method of purification. The oxidation may be effected with nitric acid (Schmidt, Ber. 1874, 7, 205; J. pr. Chem. 1874, [ii], 9, 256; Cohen and Cormier, J. Amer. Chem. Soc. 1930, 52, 4363) in which case some dinitroanthraquinone is formed, or with chromic acid in glacial acetic acid (Anschütz and Schultz, Annalen, 1879, 196, 35; Mortimer and Murphy, Ind. Eng. Chem. 1923, 15, 1140; Bachmann, J. Amer. Chem. Soc. 1935, 57, 555). In order to ensure the removal of the last traces of anthracene, a solution of the purified hydrocarbon in nitrobenzene is boiled with maleic anhydride (Clar, Ber. 1932, 65 [B], 1146) which reacts with anthracene but not with phenanthrene. Final purification of phenanthrene required for hydrogenation experiments is effected by heating with sodium at 200° and distilling. The sodium removes traces of a sulphur compound.

Other industrial methods of separating phenanthrene include the use of selective solvents with temperature and time control (Wilton and Priest, B.P. 546524; Gorelik and Taicher, Buss. P. 58326) and by the preferential sulphonation of impurities (Glösmann and Krassowitzkaja, Russ. P. 43418).

On a small scale it is often convenient to effect purification of phenanthrene in the form of its molecular compound with picric acid. The hydrocarbon can be recovered by distribution between aqueous ammonia or soda solution and ether (Limpricht, Ber. 1873, 6, 532).

Phenanthrene of high purity is stated to be produced by treating the dibromide with zinc dust (Vice, Arntzen, and Weaver, J. Amer.

Ch. T. S. 1938, 6, 287). Elopold has utilised the selective hydrogenation of impurities to obtain a product of m.p. 99-100° (Compt. rend. 1940, 211, 225).

The methods of estimating phenanthrene are based on its oxidation with iodic acid in glacial acetic acid solution to give phganthraquinone. The latter may then be precipitated with 3:4-tolylenediamine and weighed as toluphenanthrazine (Williams, J. Amer. Chem. Soc. 1921, 43, 1911; cf. Khmelevskii and Postovskii, Org. Chem. Ind. (Russ.), 1937, 4, 363), a correction being applied to allow for the slight solubility of the precipitate. Alternatively an aqueous solution of the bisulphite compound of the quinone may be converted into the quinoxaline derivative (Khmelevskii and Levin, *ibid.* 1940, 7, 241).

The amount of anthracene in a specimen of phenanthrene may conveniently be determined by the fluorescence spectrum (Hirshberg and Bergmann, Chem. and Ind. 1939, 823).

Colour reactions have been described for the detection of impurities in phenanthrene (Price, Arntzen, and Weaver, *I.e.*).

#### PREPARATION OF PHENANTHRENE AND PERIVATRINS.

Several syntheses of phenanthrene exist, but none is applicable to the industrial preparation of large quantities of the material.

Numerous methods have been developed for the preparation of derivatives of phenanthrene and a few are of such general applicability that they will be briefly described.

1. *Pschorr Synthesis* (Pschorr, Ber. 1896, 29, 496).—o-Nitrobenzaldehyde and phenylacetic acid are condensed and the resulting o-nitrostilbene carboxylic acid is converted via the amino compound into the diazonium salt which cyclises on treatment with copper powder. Decarboxylation of the product gives phenanthrene.

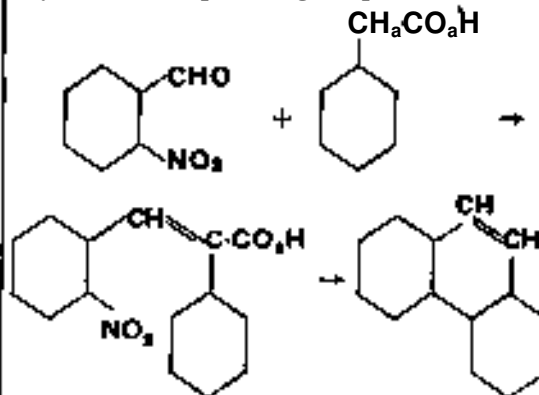

Substitution products of both starting materials can be employed for the production of a wide variety of polysubstituted phenanthrenes.

2. *Haworth Synthesis* (Haworth, J.C.S. 1932, 1125; Haworth, Mavin, and Sneldrick, *ibid.* 1934, 454).—Succinylation of naphthalene at low temperature in nitrobenzene solution in the presence of aluminium chloride gives a separable mixture of the 1- and 2-derivatives which on Clemmensen reduction give the  $\gamma$ -arylbutyric acids. These can be cyclised by treatment with 85% sulphuric acid, an alkyl group introduced by a Grignard reaction, and the product dehydrated and dehydrogenated to give an alkylphenanthrene as shown in the following partial formulae:

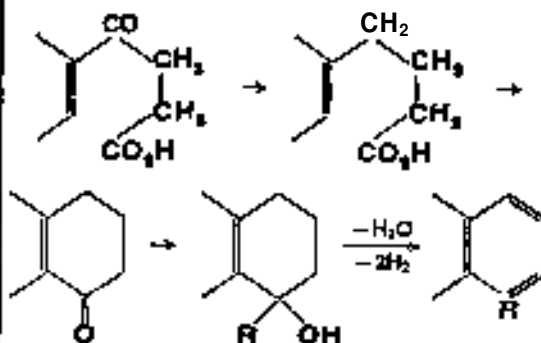

In a variation of this method the allyl group is introduced by a Grignard reaction on the ester of the naphthoylpropionic acid. The unsaturated acid thus obtained is hydrogenated and cyclised. The synthesis is completed by reduction and dehydrogenation.

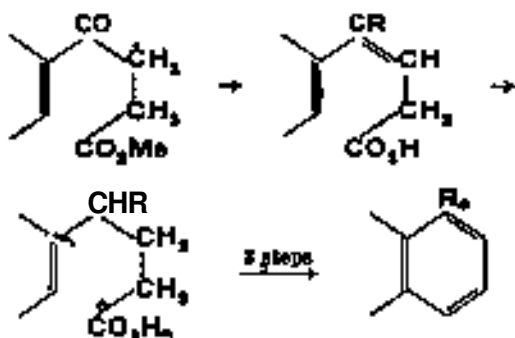

Methylsuccinic anhydride can be used, in which case condensation occurs at the less hindered carbonyl group, *i.e.*, that which is farther removed from the methyl substituent:

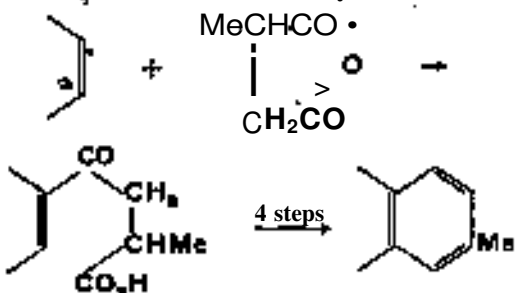

Substituents may also be introduced by carrying out the major acid synthesis on  $\alpha$ -bromo-ketone derivatives of naphthalene. The starting materials are obtained by brominating the ketones prepared by the Friedel-Crafts reaction.

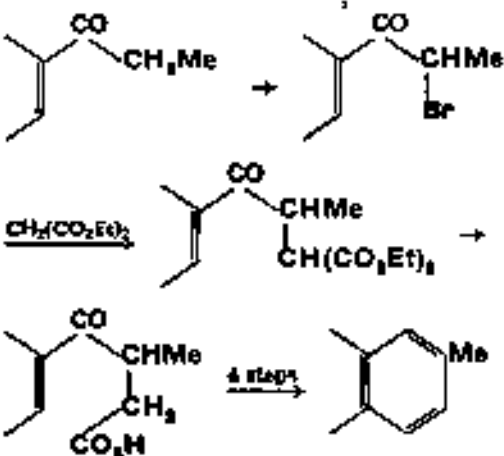

3. *Bardhar-Sengupta Synthesis* (Bardhan and Sengupta, *ibid.* 1932, 2520, 2798).—In the simplest example of this synthesis, *o*-phenylethyl bromide is condensed with the potassium derivative of cyclohexanone-2-carboxylic ester. Alkaline hydrolysis of the product is accompanied by decarboxylation. The ketone thus obtained is reduced to the alcohol, which on heating with phosphorus pentoxide in a vacuum undergoes

dehydration and cyclisation. The final stage in the synthesis consists in dehydrogenation with selenium.

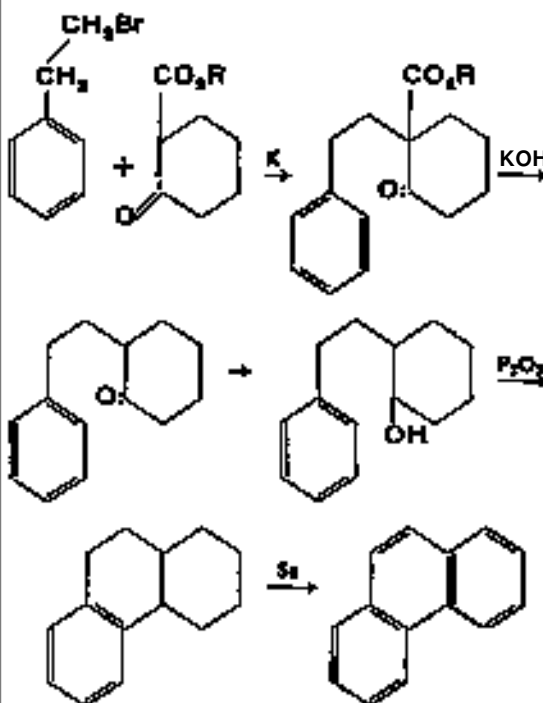

Substitution products of both the starting materials are readily available and hence the synthesis is capable of wide variation.

A synthesis similar to, but simpler than, the preceding has been devised by Perlman, Davidson, and Bogert (*v. Science*, 1933, 77, 298).

PBOPEBTIES OF PHENANTHRENE.

When pure, phenanthrene exists in colourless monoclinic scales (m.p. 101°; b.p. 332°) which are insoluble in water but readily soluble in most organic solvents, giving a blue-fluorescent solution. The absorption and fluorescence spectra of phenanthrene have been extensively investigated (*inter alia*, Johnson and Mathews, *J. Amer. Chem. Soc.* 1944, 66, 210; and Bowen and Sawtell, *Trans. Faraday Soc.* 1937, 88, 1425). Molecular compounds are formed with a large number of substances and these are often useful for purposes of identification (*e.g.*, *picrate*, m.p. 145°).

On the basis of the Fries rule, the bond structure (I) containing three normal Kekule rings, would be expected to be the most stable state of the molecule. From a consideration of the five possible valence-bond structures, each of which may be expected to contribute to the normal state of the molecule, L. Pauling, "Nature of the Chemical Bond," Cornell University Press, 1944, p. 142, has associated with the various linkages the amounts of double bond character shown in (II). It will be seen that the 9:10 bond is stated to approximate to an ordinary ethylenic bond and this is amply confirmed by the chemical reactions of phenanthrene.

Phenanthrene can give rise theoretically to five monosubstitution products and no less than twenty-six disubstitution products. As many

phenanthrene derivatives exhibit marked tendencies to polymorphism, the formation of supersaturated solutions and of mixed crystals,

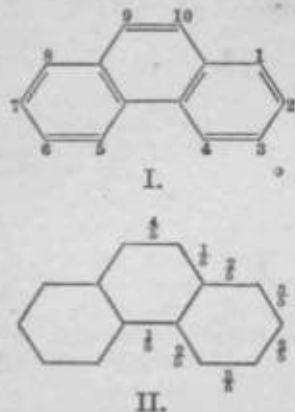

the separation of mixtures of products is often very difficult.

#### Reaction with Halogens.

Bromine combines readily with phenanthrene in cold carbon tetrachloride solution to give the 9:10-dibromide (m.p. 98°). The mechanism of this addition reaction, which is stated to proceed by a chain mechanism even in the dark, has been investigated in considerable detail (Fieser, Price *et al.*, *J. Amer. Chem. Soc.* 1936, 58, 1834, 1838, 2101, 2163; Lauer and Oda, *Ber.* 1936, 69 [B], 978; Kharasch, White, and Mayo, *J. Org. Chem.* 1938, 2, 674). The dibromide on heating at its melting-point readily loses hydrogen bromide and is converted to 9-bromophenanthrene (m.p. 63°) [*v. inter al.*, Fittig and Ostermayer, *Annalen*,

1873, 166, 363; Austin, *J.C.S.* 190S, 93, 1760), which, as a consequence of this reaction, is one of the most readily available derivatives of the hydrocarbon.

By employing 2-3 molar proportions of bromine and by carrying out the bromination at varying temperatures, a number of dibromophenanthrenes have been prepared {Henstock, *ibid.* 1923, 128, 3097}.

Reaction with chlorine gives either the 9:10-dichloride (m.p. 160°) mixed with the 9-chloro-compound or the 9:10-dichloro-compound (Sandqvist and Hagelin, *Ber.* 1918, 51, 1515). In the presence of halogen carriers, the 9:10-di- (Schmidt and Ladner, *ibid.* 1904, 87, 4403) and the 2:9:10-tri-chloro- (Schmidt and Schall, *ibid.* 1913, 39, 3892) derivatives are obtained.

#### Hydrogenation.

9:10-Dihydrophenanthrene (m.p. 35°) can be prepared by the chemical reduction of the hydrocarbon, *g.*, by the action of bromine in cold acetic acid solution (Henstock, *J.C.S.* 1921, 119, 1462) or of sodium and boiling amyl alcohol (Schmidt and Hezger, *Ber.* 1907, 40, 4240). A variety of catalytic methods have also been investigated and the derivative may conveniently be prepared (90%) by hydrogenation in the presence of nickel at 200° (*idem, ibid.*) or the copper chromite catalyst (Burger and Mosettig, *J. Amer. Chem. Soc.* 1935, 57, 2731; 1936, 68, 1857). The further hydrogenated derivatives of phenanthrene are best obtained by employing the Raney nickel catalyst under suitable conditions (Durland and Adams, *ibid.* 1937, 59, 136; 1938, 60, 1501) which are summarised below in graphical form:

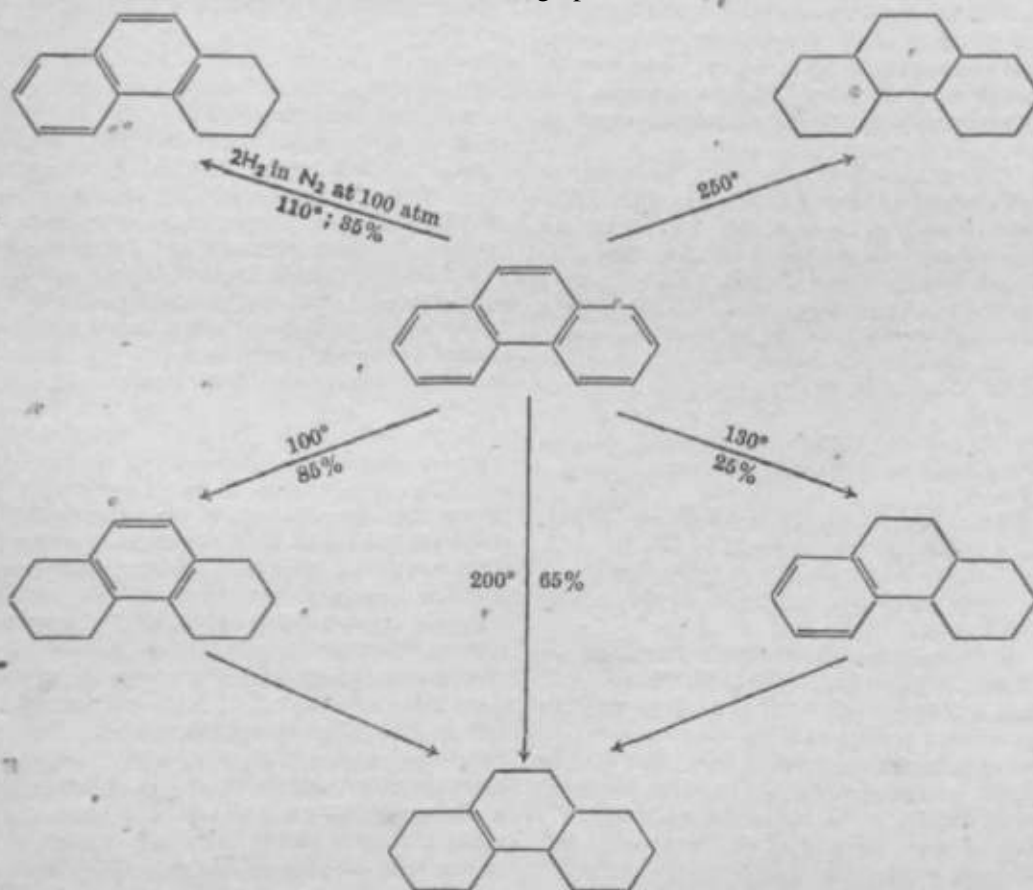

**Sulphonation.**

The positions that are favoured in the sulphonation of phenanthrene are 2, 3, 6, and 7, *i.e.*, those points corresponding to the  $\beta$ -positions in the naphthalene rings. The yields of the monosubstituted phenanthrenes obtained with 96% sulphuric acid at 60° and 120° are shown diagrammatically below:

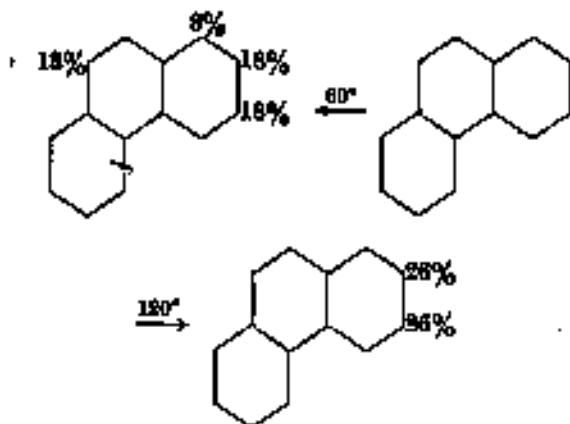

The reaction mixture resulting from sulphonation at 60° has also been shown to contain the 2:6-, 2:7-, 2:8-, 3:6-, and 3:8-disulphonic acids. From the product of sulphonation at 120°, the 2-acid is isolated as the sparingly soluble barium salt and the 3-acid by crystallisation of the potassium salt. The yield of the 2-sulphonic acid decreases with increasing time of sulphonation, *e.g.*, sulphonation with 2 mol. of concentrated sulphuric acid for 3 hours gives 25% of 2- and 27% 3-phenanthrenesulphonic acid. By increasing the time of reaction to 4 hours the yields of the acids are 18 and 27% respectively. It is noteworthy that the 1- and 9-acids do not appear among the products of sulphonation at 120°.

The monosulphonic acids may conveniently be characterised as their *ji*-toluidine salts, which crystallise well and have sharp melting-points (Fieser, *J. Amer. Chem. Soc.* 1929, 51, 2460; *cf.* Fieser and Young, *ibid.* 1931, 53, 4124; Dermer and Dermer, *J. Org. Chem.* 1942, 7, 581).«

At the higher temperature of reaction, disulphonation occurs very readily and in fact accounts for about 40% of the phenanthrene used. Disulphonic acids, however, accompany the monosulphonic acids even when phenanthrene is incompletely sulphonated at room temperature (Fieser, *l.c.*).

Further sulphonation with concentrated sulphuric acid at 120-130° of either the 2- or 3-monosulphonic acid gives a mixture of products arising from further substitution at the 6-, 7-, and 8-positions. The second sulphonic acid group is found to occupy the 6-position to a large extent. Further substitution in the same ring and attack at the 5- and 9- (10-)positions do not occur.

Ioffe (*Org. Chem. Ind. Russ.* 1940, 7, 374) has developed a method for the sulphonation of phenanthrene in the molten state with 92-94% sulphuric acid; 2- and 3-phenanthrene sulphonic acids are produced.

**Nitration.**

The nitration of phenanthrene by means of nitric acid (p 1.45) in the presence of a mixture of acetic acid and acetic anhydride gives rise to four of the five possible mononitrophenanthrenes. The yields of the various derivatives are shown diagrammatically:

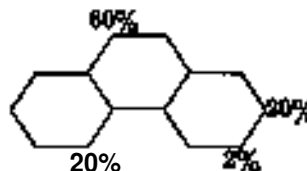

The yield of the 3-nitro-compound is increased by carrying out the nitration with nitric acid of p 1.56 at 0° (Schmidt and Heinle, *Ber.* 1911, 44, 1490).

According to Callow and Gulland (*J.G.S.* 1929, 2425), nitration of phenanthrene, under conditions similar to those of Schmidt and Heinle but by using nitric acid of p 1.5, instead of p 1.45, gives rise to some dinitro-derivative.

**9-Nitrophenanthrene** may be prepared from nitrodihydrophenanthrene oxide which is one of two addition compounds formed by reaction of phenanthrene, in benzene solution, with the "nitrous acid gas" obtained by the interaction of nitric acid and arsenious oxide. This addition product is converted by sodium methoxide into 9-nitrophenanthrene (Schmidt, *Ber.* 1900, 33, 3267).

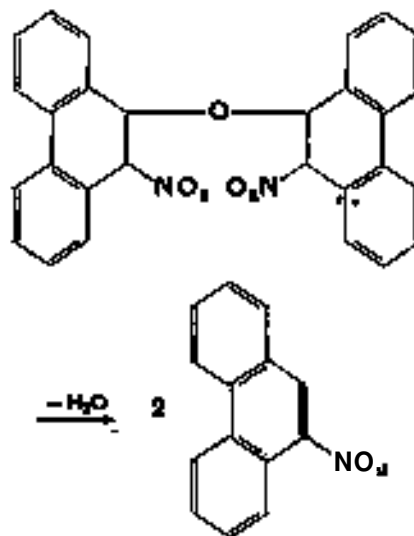

A method of nitration of phenanthrene at 0° in chloroform solution by means of nitrogen peroxide has been developed (Shorygin, Topchiev, and Anan'ina, *J. Gen. Chem. Russ.* 1938, B, 98i) and is claimed to give 100% of isomeric mononitrophenanthrenes, the 2-derivative being obtained in 32% yield.

**Acylation.**

Considerable difficulty was encountered when attempts were made to acetylate phenanthrene in carbon disulphide solution. However, the reaction was found to proceed smoothly and simply in nitrobenzene solution (Mosettig and

van de Kamp, J. Amer. Chem. Soc. 1930, 52, 3704). With acetyl chloride the 2-derivative (m.p. 143°) was prepared in 15% yield and the 3-derivative (m.p. 75°) in 64% yield. The 2-acetyl compound is less soluble and separation is easily effected by crystallisation. This reaction therefore provides a convenient method for preparing practical amounts of 3-acetophenanthrene which serves as the best source for other derivatives such as the corresponding acid and amine. The 2-acyl derivatives are, however, best prepared by the Friedel-Crafts acylation of 9:10-dihydrophenanthrene and dehydrogenation of the product. The dihydride, which may be considered as a derivative of diphenyl, is substituted exclusively at the carbon atom para to the diphenyl linkage, and the reaction is not accompanied by the usual resinous products which are obtained in the case of phenanthrene (Riegel, Gold, and Kubicek, *ibid.* 1942, 64, 2221).

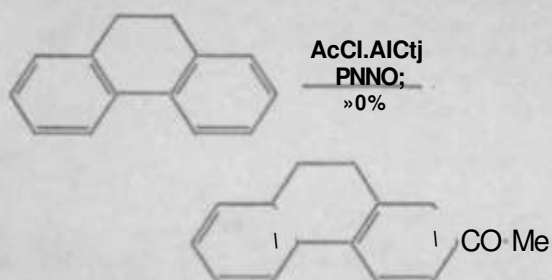

Bromination of these methyl ketones readily yields the corresponding *w*-bromoacetyl derivatives of phenanthrene (Mosettig and Von de Kamp, *ibid.* 1933, 55, 3448).

The succinylation of phenanthrene in nitrobenzene solution with succinic anhydride gives *p*-3-phenanthrolylpropionic acid (m.p. 149°) in fairly good yield (Haworth and Mavin, J.C.S. 1933, 1012).

When phenanthrene is benzoylated by a Friedel-Crafts reaction in nitrobenzene solution, attack occurs at the 1-, 2-, and 3-positions as indicated below (Bachmann, J. Amer. Chem. Soc. 1935, 57, 555; cf. Bachmann and Peace, *ibid.*, p. 1130);

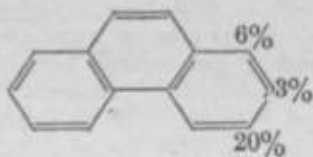

On addition of phenanthrene to a carbon disulphide solution of the Perrier compound (from benzoyl chloride and aluminium chloride), a portion of the reaction product separates as an insoluble complex which on decomposition gives exclusively the 1-benzoyl-derivative (m.p. 149.5°) in 8% yield (Bachmann, *loc. cit.*). The isolation of this ketone is so simple that it can be regarded as a readily available derivative in spite of the low yield.

#### Phenanthrylamines.

By far the most convenient method of preparing the *Q*-amine-derivative is from the phenanthrol by the Bucherer reaction, viz. heating with ammonium sulphite and ammonia in an

autoclave- (Fieser, Jacobsen, and Price, *ibid.* 1930, 58, 2163 { cf. Russ. P. 40988).

The readily available 2- and 3-acetylphenanthrenes are the best starting materials for the preparation of the 2- and 3-amino-compounds. The ketones are converted to the oximes, which are subjected to Beckmann rearrangement. The resulting *acetaminophenanthrylamine*s on hydrolysis yield the desired amines (Bachmann and Boatner, *ibid.* 1936, 68, 857, 2097; Mosettig and Krueger, *ibid.* 1936, 58, 1311; Fieser and Price, *ibid.* 1930, 58, 1838).

The 3- and 9-phenanthrylamines exist in two forms, the labile nidoform being converted into the stable one on heating, storage for some time, or on acetylation (Schmidt and Heinle, Ber. 1911, 44, 1490; cf. Cadre and Sudborough, J.C.S. 1916, 109, 1349).

The 1-, 2-, and 3-phenanthrylamines serve as starting materials in the preparation of the corresponding aldehydes (Bachmann and Boatner, J. Amer. Chem. Soc. 1936, 58, 857, 2194; Fieser and Price, *ibid.* 1936, 53, 1838). Bachmann and Boatner advocate the use of the DeMilt, and van Zandt (*ibid.* 1936, 58, 2044) method of dicotisation for weakly basic or insoluble amines and also of the introduction of chlorine and bromine atoms by Schwechten's modification of the Sandmeyer reaction (Schwechten, Ber. 1932, 65 [B], 1605).

#### Phenanthrols.

Owing to their relationship with some opium and Corydalis alkaloids, the phenanthrols have been investigated in some detail (*see* Knorr and Pschorr, *ibid.* 1905, 38, 3174). All the five possible hydroxy-derivatives of phenanthrene have been prepared but only the 2-, 3-, and 9-phenanthrols (m.p. 169, 123, and 153° respectively) are readily available.

Both 2- and 3-phenanthrol are easily obtained from the corresponding sulphonate. Mosettig and Burger (J. Amer. Chem. Soc. 1935, 57, 2189) have described a practical method of preparing 1-phenanthrol in 50% yield by bromination of 1-keto-1:2:3:4-tetrahydrophenanthrene and dehydrobromination of the product by treatment with diethylaniline.

Several methods have been employed for the preparation of 9-phenanthrol (*phenanthrone*) of which only two will be mentioned here. Treatment of phenanthraquinone with phosphorus pentachloride gives 10:10-dichloro-9-phenanthrone which on reduction, best with stannous chloride in acetic acid saturated with hydrogen chloride, gives phenanthrone (Schmidt and Lumpp, Ber. 1908, 41, 4215; Goldschmidt, Vogt, and Bredig, Annalen, 1925, 445, 135);

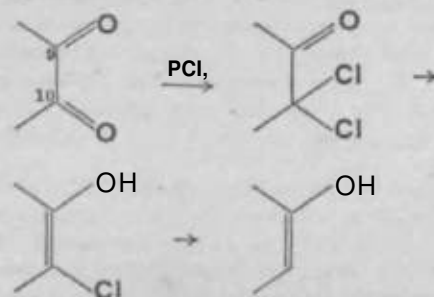

This compound is now easily obtained by the method of Fieser, Jacobsen, and Price (J. Amer. Chem. Soc. 1936, 58, 2163). These authors found that phenanthrene on treatment with bromine in methanol solution was converted into an unstable complex apparently consisting of 1 mol. of phenanthrene methoxybromide and one of the dibromide. This complex gives 9-methoxyphenanthrene and phenanthrene when warmed with alcoholic potassium hydroxide-acetate, and 9-phenanthrol is easily obtained (30% yield based on phenanthrene consumed) from the mixture.

#### Phenanthrene Carboxylic Acids

The readily available 2- and 3-acetylphenanthrenes can be converted in almost quantitative yield to the corresponding carboxylic acids (m.p. 254° and 269° respectively) by oxidation with sodium (or\* preferably calcium) hypochlorite solution (Mosettig and\* van de Kamp, *ibid.*, 1930, 52, 3704). This method has also been applied for the preparation of the 4-acid (Fieser, and Hershberg, *ibid.* 1936, 58, 2322).

**Phenanthrene-9-carboxylic acid (imp. 252°)** can conveniently be prepared in good yield from the 9-bromo-compound by two alternative routes: (1) conversion to the Grignard reagent followed by either direct carbonation, or condensation with ethyl chlorocarbonate and hydrolysis of the resulting ester (Bachmann, *ibid.* 1934, 56, 1363); (2) conversion to the nitrile by heating with cuprous cyanide at 260° followed by hydrolysis (Mosettig and van de Kamp, *ibid.* 1932, 54, 3328). Phenanthrene nitriles may also be prepared, and hence the acids by hydrolysis, from the sulphonic acids (Schultz and Japp, Ber. 1877, 10, 1661; Japp, J.C.S. 1880, 37, 83; Werner and Kunz, Annalen, 1902, 321, 323; Fieser, J. Amer. Chem. Soc. 1932, 54, 4110).

#### Phenanthraldehydes\*

The 2-, 3-, and 9-aldehydes may be prepared in excellent yield by reduction of the acid chlorides in decalin solution by means of the Rosenmund method (Mosettig and van de Kamp, *ibid.* 1933, 55, 2995). The conversion of the acid chlorides to the aldehydes by means of the Sonnfeld-Müller method results in lower yields (Shopee, J.C.S. 1933, 37; Bachmann, J. Amer. Chem. Soc. 1935, 57, 555; Bachmann and Boatner, *ibid.* 1936, 58, 2097; Bachmann and Kloetzel, *ibid.* 1937, 59, 2207).

Phenanthrene-9-magnesium bromide reacts with ethyl orthoformate to give the acetal, from which the aldehyde may be obtained by hydrolysis (Miller and Bachman, *ibid.* 1935, 57, 766).

When subjected to a Gattermann reaction in chlorobenzene solution, phenanthrene is attacked in the reactive 9-position and the 9-aldehyde is obtained in 44% yield (Hinkel, Ayling, and Beynon, J.C.S. 1936, 339).

#### Phenanthraquinone.

Oxidation of phenanthrene proceeds by means of an attack on the reactive 9:10-positions with formation of a typical ortho-quinone. The hydrocarbon can be oxidised in glacial acetic acid solution with chromic acid (Graebe,

Annalen, 1873, 167, 140) or, more economically, in aqueous suspension using potassium dichromate (Anschütz and Schultz, *ibid.* 1879, 196, 37; Oyster and Adkins, J. Amer. Chem. Soc. 1921, 43, 208). The yield obtained is 50-60%. The orange-coloured phenanthraquinone is easily purified by extraction from the reaction mixture as the colourless, water-soluble bisulphite compound from which the quinone may be regenerated by acidification or addition of alkali (Graebe, Annalen, 1873, 167, 131). In this manner all traces of anthraquinone can be removed. Phenanthraquinone is itself easily oxidised further, by cleavage of the bond between the two carbonyl groups, to diphenic acid. This fact constitutes the chief difficulty in obtaining a high yield of the quinone. The further oxidation of phenanthraquinone is most conveniently effected with hydrogen peroxide in either glacial acetic acid solution (Holleman, Rec. trav. chim. 1904, 23, 169) or alkaline medium (Weitz, Schobbert, and Seibert, Ber. 1935, 62 [B], 1163).

Other methods of oxidation have been employed, however, and include sodium chlorate and acetic acid in the presence of ruthenium salts (Badische, G.P. 275518), electrolytic oxidation in the presence of manganese sulphate (Lang\* G.P. 189178) or cerium sulphate (Meister, Lucius, and Briining, G.P. 152063; B.P. 19178, 1902).

Alkylphenanthrenes in which the 9- and 10-positions are unsubstituted are smoothly oxidised to the alkyl-9:10-phenanthraquinones with chromic acid. Similarly most substituted phenanthrenes can be converted into the 9:10-quinones; hydroxyl and amino groups may be adequately protected by acetylation. It is by this method that the majority of the derivatives of phenanthraquinone are prepared, since direct substitution of phenanthraquinone usually takes place at the 2- and 7-positions (*cfi* the meta directing effect of a carbonyl group on further substitution in a benzene ring).

Oxidation of aminophenanthrols has been employed for the preparation of the 1:2-, 1:4-, and 3:4-phenanthraquinones (Fieser, J. Amer. Chem. Soc. 1929, 51, 946, 1896, 2469), but these compounds are not of great importance.

A substituent in the central ring of phenanthrene is eliminated in the process of oxidation and a 9:10-quinone is again produced. This reaction frequently finds application in the elucidation of the structures of phenanthrene derivatives.

**Properties.**—Phenanthraquinone crystallises in long needles (m.p. 205°), may be boiled (>360°) without decomposition and on sublimation gives orange-red prisms. It exhibits polymorphism (Lindpaintner, Mikrochem. 1939, 27, 21). The spectrographic properties have been studied (Seshan, Proc. Indian Acad. Sci. 1936, 3A, 172).

A sensitive colour test which is capable of detecting 0.0005 g. of phenanthraquinone has been described (Laubenheimer, Ber. 1875, 8, 224; Meyer, *ibid.* 1883, 16, 1624, 2972).

Chemically, phenanthraquinone resembles 0-naphthaquinone, but differs from the latter in that it can be prepared by direct oxidation of the hydrocarbon.



The quinone forms a phenylwrazone (m.p. 162-163°) (Werner and Froy, *J. & A. J.*, 1902, 321, 304) and both a mono- (m.p. 158°) and di-oxime (m.p. 202°) (Meyor and Auwers, *Ber.* 1SS9, 22, 19S9). The oximea form complex metallic salts and the monoxime is a very sensitive reagent for cobalt and ferrous salts (Ciusa, *Gazzetta*, 1936,66,591).

In the presence of alkalis, phenanthraquinones undergo the benzilic acid rearrangement. This fact accounts for the formation of fluorenone (m.p. 84°) when phenanthrene is oxidised with alkaline potassium permanganate (Anschütz, and Japp, *Ber.* 1878,11, 211).

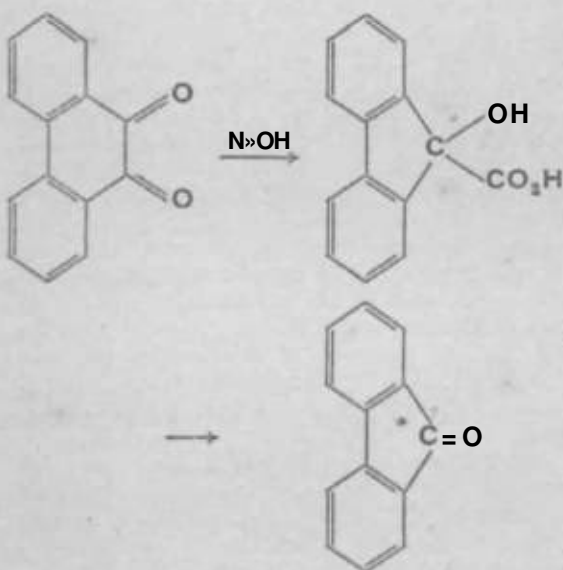

Phenanthraquinone and its derivatives, by virtue of the  $\alpha$ -diketone grouping they possess, undergo condensation reactions with a large variety of chemical compounds. Among the products produced are some which are claimed to have tinctorial properties and to have application in the dyestuff field, but none has attained any eminence industrially. Among the many classes of compounds that have been employed in these condensations may be cited the following: orthodiamines (Badische, G.P. 79570; 90212; Sircar and Butt, *J. Indian Chem. Soc.* 1924, 1, 201; Dutta, *Ber.* 1933, 66 [B], 1220), diaminoftntliraqui nones (Scholl and KoCer, *ibid.* 1904, 87, 4532), substituted phenylhydraxines (Guha and De, *J. Indian Chem. Soc.* 1926, 3, 55), substituted anilines (Fries, G.P. 130743; Sircar and Roy, *J.C.S.* 1924, 125, 543), aromatic aldehydes and their derivatives (*idem, ibid.* 1925, 127, 1048, Sircar and Sircar, *ibid.* 1923, 123, 1500) and various thio- compounds (Guha *et al.*, *J. Indian Chem. Soc.* 1927, 4, 242; 192S, 5, 155; De, *ibid.* 1930, 7, 361; Schiinberg and Schutz, *Ber.* 1927, 60 [BJ, 2347). Fonsome other mordant, vat, or azine dyea derived from phenanthraquinone, *cf.* Mukherjise and Watson, *B.P.* 9311,1915; *J.C.S.* 1916,109, 617; Watson and Dutt, *ibid.* 1921, 119, 1211.

The quinone forms a *dibromide* (Schmidt and Junglmus, *Ber.* 1904, 37, 3556). The 2-*bromo-phenarlhsaquinone* (m.p. 233°), also formed as a minor product, is prepared in better yield by bromination at 100° under pressure. Further bromination at 150-160° gives the 2-*l-dibromo-*

derivative (m.p. 323°). The 3-*6-iaamer* is stated to be prepared in nitrobenzene solution (Courtot and Kronstein, *Chira. et Ind.* 1941, 45/66).

When phenanthraquinone is boiled with concentrated nitric acid for a short time the 2- (m.p. 257-258°) and the 4- (m.p. 179-180°) *nitro-derivatives* are obtained (Schmidt and Austin, *Ber.* 1903, 36, 3731; Schmidt and Kampf, *ibid.*, p. 3730. Further nitration gives the 2-7- (m.p. 3W) and the 4-5- (m.p. 228°) di-substitution products (Schmidt and Kampf, *I.e.*).

Phenanthraquinone, or its bisulphite compound, can be reduced to 9:10-*dihydroxyphenantftrene* (Schmidt and Kampf, *ibid.* 1902, 35, 3121; Knesch, G.P. 151981). Its conversion to *phcnanthTol* has already been mentioned.

Phenanthraquinone can be completely hydrogenated over platinum at room temperature and over Kaney nickel at 60° without loss of oxygen. The products obtained are *perhydro-9ilO-dihydroxyphenanikyenea* (Liustead and Levine, *J. Amer. Cem. Soc.* 1942, 64, 2022). Over nickel at 120°, hydrogenation yields mainly *decahydro-QAO-dihydroxyphenaiithrene* (*cf.* Skita, *Bor.* 1925, 68 [BJ, 2685).

B. C. L. W.

PHENAZONE. 1 - Phenyl • 2&- dimethyl-6 - pyrazolone. " *Anlipyrine.*" Antipyretic. B.P., B.P.C. (p. SYNTHETIC DfUGS).

PHENOBARBITONE. fi-PhenyI-5-ethyl- barbiturio acid. " *LuminaV* Hypnotic and sedative; used in treatment of epilepsy. B.P., B.P.C. (v. SYNTHBTIO DRUGS).

PHENOBARBITONE SOLUBLE.

Sodium 6 - phSnyl - &- ethylbar^aturate. Hypnotic and sedative. B.P., B.P.C. (v. SYNTHETIC DBUQS).

S. E.

PHENOL AND ITS HOMOLOGUES."

Replacement of one of the BUC hydrogen atoms in benzene by the hydroxyt group gives phenol (also known as carbolic acid), *i.e.*, monohydroxy-bonzone, which is the first member of a very important homologous series, the inonohydrk phenols. The other members of this soriea are formed by replacement of one up to five of the remaining hydrogen atoms by alkyl groups. It will be clear that position isomerism of the hydroxyl and aUtyl groups in the benzene ring can occur, as well as isomerism in the alkyl side chains themselves in the case of alkyl substituents higher than ethyl; relatively large numbers of isomeric phenols can therefore exist when the substituent or substituents are from among the higher alkyl groups. Thus, in the case of methyl substituted hydroxybenzene, the methyl group can occupy one of three positions, ortho-, meta-, or para- with respect to the hydroxy-group. The three isomers resulting are the so-called cresols. With two methyl substituents it is easily seen that six isomers are possible, the so-called xylenea. The position is similar for ethyl substituents. With onepropyl substituent, there are three position isomera resulting from isomerism in the ring, and two possible propyl isomers leading to the existence of six isomeric propyl phenols, and so on with other alkyl substituted phenols.



The most important monohydric phenol is phenol itself, followed by the alkyl phenols in which there are only one or two alkyl substituents and in which the alkyl substituents have a relatively small number of carbon atoms.

If two of the hydrogen atoms in benzene are replaced by hydroxyl groups, it is apparent that there can exist three isomers, the ortho-, meta-, and para-dihydroxybenzenes, known respectively as catechol, resorcinol, and hydroquinone, which, in a manner strictly analogous to the case of phenol, form the first members of other homologous series, the dihydric phenols.

In like manner are formed the homologous series of tri-, tetra-, and penta-hydric phenols. When six hydrogen atoms in benzene are replaced by hydroxyl groups, hexahydric phenol results, and is the sole member of the homologous series. In the case of these polyhydric phenols, only the unsubstituted di- and tri-hydric phenols are of industrial importance.

#### General Properties.

**Physical.**—When pure, phenols are white solids or colourless liquids at room temperature.

Monohydric phenols have very characteristic burning tastes, and odours varying from the bland sweetish smell of the lowest member of the series, phenol, to the sharp spicy type of smell possessed by the higher homologues. The dihydric phenols have slight odours, while the tri-, tetra-, penta-, and hexa-hydric phenols are almost odourless.

Monohydric phenols are soluble in water at room temperature, the solubility decreasing from about 7-5% in the case of phenol, to below 0.2% in the case of the higher homologues such as butylphenol; polyhydric phenols are much more soluble. In organic solvents, monohydric phenols are, in general, easily soluble, especially in oxygenated solvents; the polyhydric phenols are easily soluble in oxygenated solvents but much less soluble, or in the case of the tri- and higher poly-hydric phenols, only slightly soluble in other organic solvents.

All phenols have antiseptic and germicidal properties, the effect increasing to a maximum on increasing the length of the alkyl side chain substituents to about six carbon atoms, and being affected by the number of hydroxyl groups present.

Phenol, the lowest member of the monohydric phenols, is highly toxic and caustic, the cresols being less so, with a further progressive falling off as the higher members of the series are reached. Polyhydric phenols, while being less caustic than the monohydric, are still markedly toxic; the toxicity appears, in part at least, to be associated with their general strong reducing properties.

**Chemical.**—Phenols behave as weak mono- or poly-basic acids, depending upon the number of hydroxy-groups present, the acidity diminishing with increase in length of the alkyl substituent side chains, and with the number of alkyl substituents. The hydroxy-group in phenols also exhibits properties similar to that in the alcohols, especially tertiary alcohols. Thus, phenols form esters with acids, and ethers by condensation with other phenols or alcohols.

The presence of the hydroxyl group in phenols facilitates the substitution of the hydrogen atoms attached to the benzene nucleus, by such substituents as the halogens, cyano-groups, nitro-groups, sulphonic acid groups, amino-groups, etc., and large numbers of phenols so substituted are known. The substitution of hydrogen, by azo-groups is especially important, since a considerable number of azo dyes (*q.v.*) are thus prepared. The reaction is, in general, carried out by reaction between diazo-compounds (*q.v.*) and sodium salts of phenols in aqueous alkaline solution.

Heating phenols with zinc dust results in partial reduction to the parent hydrocarbon, *e.g.*, phenol itself gives benzene.

Reaction of phenols, especially nitro-phenols, with phosphorus pentachloride results in the substitution of the hydroxyl group by chlorine; with phosphorus sulphide, thiophenols are produced. Heating phenols under pressure with aqueous ammonia results in the replacement of  $\text{-OH}$  by  $\text{-NH}_2$ , giving aniline or nuclear substituted anilines.

Dialkyl salts of phenols are converted by carbon dioxide at temperatures around 150–200°C. to the alkali salts of ortho- and/or para-phenolcarboxylic acids; *e.g.*, phenol gives salicylic acid (*q.v.*). These carboxylic acids are also formed by heating aqueous alkali phenates with carbon tetrachloride. If chloroform is substituted for carbon tetrachloride, the corresponding aldehydes are formed.

With formaldehyde, phenols react to give phenol alcohols thus: \*

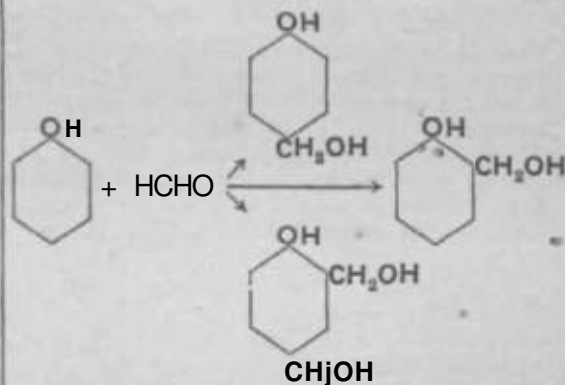

which can further condense to give phenol-formaldehyde resins (*v. PLASTICS*). These resins have, during the past 20 years, found many important uses, and their manufacture absorbs a substantial percentage of the world's phenol production.

On reaction with benzotrichloride, phenols give triphenylmethane derivatives, which are the parent substances for certain triphenylmethane dyestuffs.

Phthalic anhydride reacts with phenol to give the phthaleins.

Catalytic reduction of phenols with hydrogen under suitable conditions gives substituted cyclohexanols or cyclohexanones; substituted tetra- and hexa-hydrobenzenes are also obtained.

With powerful oxidising agents, such as permanganate in aqueous solution, phenols can be completely oxidised to carbon dioxide and water.

TABLE I.

Phenol.	M.p. or p.p. (crystal- ising point), °C	Boiling point, °c. at mm. Hg.				Density, g. per ml. at t° C
		760.	400.	100.	20.	
Phenol	41-0 (i)	181-7 (0)	1600 (6)	120-2 (6)	85-8 (6)	1-073/20 (i)
o-Cresol	31-0 (j)	191*0 (i)	168-4 (6)	127-4 (6)	96-6 (6)	1-051/20 (i)
m-Cresol	12-0 (i)	202-2 (0)	1790 (6)	138-0 (6)	101-3 (3)	1-035/20 (i)
p-Cresol	34-7 (i)	202-0 (0)	179-4 (6)	138-4 (6)	101-8 (3)	1-035/20 (i)
o-3-Xylenol	75-0 (i)	218-0 (0)	—	160(2)	112(2)	—
o-4-Xylenol	65-0 (1)	227-0 (i)	—	160 (2)	122(2)	—
m-2-Xylenol	450 (0)	201-0(1)	* —	—	—	—
m-4-Xylenol	26-0 (0)	211-5 (i)	—	143 (2)	105 (2)	1-026/20 (0)
w-5-Xylenol	640 (i)	221-5 (i)	—	155(2)	117-6(2)	1-017/20 (i)
p-2-Xylenol	75-0 (0)	211-5 (i)	—	143 (2)	105 (2)	1-026/20 (i)
o-Ethylphenol	< -18 (2)	206-5(3)	—	138-5 (2)	101-5 (2)	-037/f <sup>(2)</sup>
m-Ethylphenol	-40(2)	214(2)	—	IK (2)	114-6 (2)	iWf <sup>(2&gt;</sup>
p-Ethylphenol	470(2)	218-5-219-5 (3)	—	153(2)	115(2)	ion/f><2>
Mesitol (2:4:6-Trimethyl-phenol)	68-69 (3)	219-5 (3)	—	—	—	—
Cuminol (2:3:5-Trimethyl-phenol)	95(3)	230-231 (3)	—	—	—	—
Hemellitphenol (3:4:5-Trimethylphenol)	81(3)	—	—	—	—	1
2:3:4-Trimethylphenol (consecutive 0-cuminol)	62(7)	—	—	—	—	—
2:4:5-Trimethylphenol	71-72(3)	234-235 (3)	—	—	—	—
o-Propylphenol	—	224-0-226-8 (3)	—	—	—	—
o-isoPropylphenol	16-16(3)	212-0-213-6 (3)	—	—	—	—
m-Propylphenol	26(3)	228 (3)	—	—	—	—
iw-woPropylphenol	47-48(3)	260-262, d. (3)	—	—	—	—
3>-Propylphenol	—	230-232-6(3)	—	—	—	—
2-Methyl-4-ethylphenol	—	224-5/740	—	—	—	—
		mm. (*)				
2-Methyl-5-ethylphenol	—	224 O	—	—	—	—
2-Methyl-6-ethylphenol	—	212-214 (10)	—	—	—	—
3-Methyl-4-ethylphenol	26(7)	235(7)	—	—	—	—
3-Methyl-5-ethylphenol	51 (4)	233 (7)	—	—	—	—
3-Methyl-C <sup>h</sup> ylphenol	43-44(W)	—	—	—	—	—
4-Methyl-3-ethylphenol	—	234-235 (7)	—	—	—	—
4-Methyl-6-ethylphenol	—	216-218(8)	—	—	—	—
2-Propyl-4-methylphenol	—	—	—	—	128-130/ 27 mm. <sup>(B)</sup>	—
Thymol (3-Methyl-6-wo-propylphenol)	51-5 (»)	231*8 (»)	—	—	—	0-969 (")
Carvacrol (2-Methyl-5-wo-propylphenol)	05 (")	237*9(11)	* —	—	—	0-976 (ii)
o-fert.-Butylphenol	—	221 (2)	—	153 (2)	114 (2)	—
?-te/*.-Butylphenol	100X <sup>2</sup> )	237(2)	—	170(2)	130-5 (2)	0-908/14 (2)
2:4-Dimethyl-6-ethylphenol	—	227-228 (10)	—	—	—	—
3:4-Dimethyl-6-ethylphenol	51-52(W)	—	—	—	—	—
p-ferf.-Amylphenol	93(2)	262-5(2)	—	—	138-5 (2)	0-962/20(2)
3-Methyl-4-amyphenol (Amyl-m-cresol)	—	—	—	—	—	—
p-di <sup>o</sup> -BUylphenol	84(5)	280-283 (*)	—	—	—	—
2:4:5-Trimethyl-6-ethyl-phenol	47-49 (10)	250-252 (10)	—	—	—	—
2:3:4:5-Tetramethylphenol	86-87 (3)	248-250 (3)	—	—	—	—
2:3:4:6-Tetramethylphenol	80-81 (3)	—	—	—	—	—
2:3:5:6-Tetramethylphenol	117(3)	249-250(3)	—	—	—	—
Pentamethylphenol	125(3)	267(3)	—	—	—	—

1 Standardisation of Tar Products Tests Committee,  
 "Standard Methods for Testing Tar and its Products,"  
 2nd ed., 1938, p. 380.  
 2 Pardee/ind Weinrich, Ind. Eng. Chem., 1944, 36, 596.  
 3 U.S. Bur. Mines Bull. Tech. Papers and Report In-  
 vest. No. 2968.  
 < Eruber and Schmitt, Ber. 1931, 64 [B], 2270.  
 ' Niederl, Ind. Eng. Chem. 193d, 30, 1269.

6 Kahlbaum, Z. Physik. Chem. 1898, 26, 603.  
 7 Morgan and Pettit, J.C.S. 1934, 418.  
 > Hill and Graf, J. Amer. Chem. Soc. 1915, 37, 1843.  
 9 Clemmensen, Ber. 1914, 47, 51.  
 10 Auwers, Bundesmann, and Wieners, Annalen,  
 1898, 447, 167.  
 "Int. Crit. Tables, Nat. Bes. Council U.S.A., 1st  
 ed., 1926, Vol. I, p. 2^7.

By suitable control of the conditions, intermediate products such as oxalic or tartaric acids can be isolated.

Space will not permit more than the above brief outline of the properties being given here, and for a good detailed review, and a full bibliography of the subject, the reader is referred to "Traite de Chimie Organique," Tome VI (publie sous la direction de Victor Grignard, G. Dupont, et R. Locquin; Massoitfet Cie, Editeurs, Paris, 1940).

A. THE MONOHYDRIC PHENOLS.

*Physical Constants.*—Useful physical constants of some of the most important and better known monohydric phenols are given in Table I, together with such incomplete data as is available for some of the less well-known members of the series. Literature references are given in brackets thus (\*) by the side of the physical

constants, the key to these numbers being given immediately after the table. In order to avoid unduly lengthening the literature references, some of the very early ones are taken from a collected data review (6).

*Characterisation.*—Derivatives of the monohydric phenols suitable for use in characterisation, and also in certain cases for qualitative separation of mixtures, are: (i) the aryloxy-acetic acids usually prepared by reaction between the sodium salt of the phenol and sodium chloroacetate in aqueous solution; (ii) the phenylurethanes made by reaction between the dry phenol with phenylisocyanate at 100°C.; (iii) the xenylurethanes similarly formed from the dry phenol and ^-xenylisocyanate at 110°; and (iv) the 3:5-dinitrobenzoates formed by warming the phenol and acid chloride, and crystallising the product from a suitable solvent. Table II gives the melting-points of a number of these derivatives.

TABLE II.

Phenol.	Derivatives, with m.p., °o.			
	Aryloxyacetic acid.	Phenyl methanes.	Xenyl methanes.	3:5-Dinitrobenzoates.
Phenol	98-99 (i)	120 (11)	173 (12)	145-8 (13)
o-Cresol	151-152 (3)	144 (11)	151 (12)	138-4 (13)
m-Cresol	102 (3)	125 (11)	164 (12)	165-4 (13)
p-Cresol	135-136 (5)	115 (11)	198 (12)	188-6 (13)
m-2-Xylenol	140-141 (5)	138 (11)	198 (12)	158-8 (13)
m-4-Xylenol	141-6 (4)	112 (11)	184 (12)	164-6 (13)
p-2-Xylenol	118 (4)	162 (11)	202 (12)	137-2 (13)
o-3-Xylenol	185-187 (5)	176 (11)	—	—
w-5-Xylenol	111 (1)	—	150 (10)	195-4 (1)
o-4-Xylenol	162-5 (8)	130 (11)	183 (10)	181-6 (13)
o-Ethylphenol	140-141 (3)	141 (11)	—	—
m-Ethylphenol	75-0-75-5 (3)	138-8 (11)	—	—
p-Ethylphenol *	96-97 (3)	120 (3)	—	—
2:3:6-Trimethylphenol (i) (consecutive <i>tp</i> -cumenol)	—	—	189 (13)	—
2:4:5-Trimethylphenol (i) (0-cumenol)	—	110 (13)	196 (13)	—
2-Methyl-5-ethylphenol (i)	—	—	160 (13)	—
2-Methyl-6-ethylphenol (1)	—	150-15K")	—	—
3-Methyl-4-ethylphenol (1)	—	—	152 (13)	—
3-Methyl-5-ethylphenol (1)	—	151 (13)	125 (13)	—
3-Methyl-e-ethylphenol (1)	—	—	—	—
4-Methyl-2-ethylphenol (1)	—	127-12S(ii)	—	—
4-Methyl-3-ethylphenol (1)	—	99 (11)	168 (11)	—
4-Methyl-6-ethylphenol (1)	—	101 (11)	—	—
2-Propyl-4-methylphenol (1)	—	99 (12)	—	—
Thymol	—	106 (10)	194 (10)	103-2 (13)
Carvacrol	—	135 (10)	166 (10)	76-77 (i*)
2:4-Dimethyl-6-ethylphenol (0)	—	113-5(11)	—	—
3:4-Dimethyl-6-ethylphenol (13)	—	51-52(13)	—	—
2:4:5-Trimethyl-6-ethylphenol (1)	—	136-138(11)	—	—

1 Hantzsch, Ber. 1886,19,1296.  
 2 Oglialoro and Gannonè, Gazzetta, 1888,18, 511.  
 3 Oglialoro and Foret, Gazzetta, 1890, 20, 508.  
 4 Gabriel, Ber. 1881,14, 923.  
 5 Steinknopf and (HSpner, J. pr. Chem. 1926, [il], 113,137.  
 \* Gluud and Breuer, Ges. Abh. Kennt. Kohle, 1918, 2, 257.  
 7 U.S. Bur. MineB, Bull. Tech. Papers and Report Invest. No. 2968.  
 • Fromm and Eckard, Ber. 1923 56 [B], 953.

9 Phillips and Keenan, J. Amer. Chem. Soc. 1931, 53, 1924.  
 10 Morgan and Pettet, J.C.S. 1931,1124\*  
 11 Auwers, Bundesmann, and Wieners, Annalen, 1926, 447, 162.  
 12 Hill and Graf, J. Amer. Ghem. Soc. 1915,37,1843.  
 13 Morgan and Pettet, J.C.S. 1934, 418.  
 14 X. M. Heilbron and H. M. Bunbury, " Dictionary of Organic Compounds/ 2nd ed., Eyre and Spottiswode, 1943.

Wales and Palkin (J. Amer. Chem. Soc. 1926, 48,810; cf. Formánek and Knop, Z. anal. Ghem. 1917, 56, 273) proposed to characterise phenols by spectroscopic examination in various solvents of the azo dyes formed from them by coupling with jMiitrobenzenediazonium chloride. The adsorption bands, however, tend to be broad,

and the differences in maxima between closely related phenols rather small. Of much greater interest is the recdht work by Thompson *et al.* (J.G.S. 1945, 268; Trans. Faraday Soc. 1945,41,279,200) which has shown that the infra-red absorption spectra for a number of different phenols in the range 7-15/t.

are highly characteristic, as is the case with many other groups of compounds. Extension of this method should form the basis of a general method of characterisation.

*Sources.*—When organic matter, especially that of vegetable origin, is destructively distilled, phenols are usually found in the distillates; destructive distillation or carbonisation of coal, as in gasworks or coke-oven plants (v. Vol. III, 258), gives as distillate coal tar (cf. Vol. III, 207) containing up to 50% phenol, cresols, xylenols, and other higher phenol homologues, the proportion of the various phenols and the total amount depending upon the kind of coal carbonised, and upon the conditions of carbonisation. Coal tar forms one of the main sources of these phenols (for detailed methods of manufacture, see Vol. II, 303; Vol. III, 424, 426).

Petroleum distillates often contain appreciable amounts of phenols and its homologues. The phenols are isolated from the distillates to a considerable extent in the U.S.A. and probably also in Russia.

Certain essential oils, obtained by pressing or steam distilling seeds or leaves of certain plants, contain phenols, and often form valuable commercial sources: thus a considerable amount of thymol is obtained from Indian Ajowan Seed Oil. The essential oils of Origanum and Thyme, depending upon their origin, contain up to 60-80% of thymol or carvacrol. For fuller details, see Bull. Imp. Inst. 1924, 22, 265; Pellini, Annali Chim. Appl. 1923, 13, 97.

Modern demands, however, for many phenols are such that the so-called natural sources mentioned above are totally inadequate, and accordingly the phenols have largely to be manufactured by synthetic methods, as is the case with phenol itself, and its homologues carvacrol and thymol, to mention only three. In some cases no natural sources of the phenols are known, and thus they have to be obtained by synthetic methods, e.g., *p*-tert.-sulnyl- and *p*-tert.-octyl-phenols.

### Phenol (Carbolic Acid).

This has been dealt with at length in the article on CARBOLIC ACID (Vol. II, 303c); additional information given here will serve to supplement the earlier data.

#### *Manufacture.*

*Natural Phenol (so called) from crude Carbolics and Cresylics (Tar Acids) obtained from Coal Tar.*—Continuous vacuum fractional distillation, worked so largely in the petroleum industry, has, in recent years, been adapted to the separation of phenol, especially in the U.S.A. and to a lesser extent in this country. By suitably designing columns and working at reflux ratios appropriate to the crude tar acids being distilled, it is possible to obtain, directly, phenol of o.p. 39-41°j.p. which is of sufficient purity for many uses other than pharmaceutical. One of the advantages over other methods, involving batch distillation and refrigeration, is the marked saving in energy requirements per unit of phenol produced.

*Synthetic Phenol.*—(a) The classical benzene-sulphonation alkali-fusion method, as befits its importance (indicated by the fact that a large proportion of the synthetic phenol made is still produced by this method), continues to engage attention directed to ways and means of improving its economics, to enable it to meet increasing competition from the newer methods: (i) Kokatnur (U.S.P. 2111973; cf. Othmer and Leyes, Ind. Eng. Chem. 1941, 33, 158) proposes the use of partial-pressure evaporation techniques in both the sulphonation and fusion stages. Benzene is sulphonated in the presence of a high-boiling naphtha cut, and the resulting sodium benzenesulphonate obtained after neutralisation is fused with caustic soda in a high-boiling kerosene fraction. Only a very small excess of sulphuric acid and of caustic soda (1.5%) over theory are required. A yield of 92% theory of phenol on benzene is indicated, (ii) Bouvier *et al.* (B.P. 406646; 416930; U.S.P. 1998167; cf. Tyrer, B.P. 554878; 559642) claim a process for economising in alkali in manufacturing phenol and homologues by carrying out the fusion of the benzene or other sulphonates in molten sodium phenates, and carrying over the phenol produced by hydrolysis of the phenate in a current of steam passed through the reactants in the temperature range of 280-370°C, thus leaving free caustic to react with the sulphonates to give further phenol (cf. Tyrer, B.P. 554878; 559642, which claims the use of inorganic bases other than caustic alkali), (iii) Miller (U.S.P. 2378314) and Harris (U.S.P. 2353237), pointing out some inherent disadvantages in the standard fusion technique, claim a continuous fusion method which involves feeding the reactants, sulphonates and caustic soda, into an agitated horizontal reaction vessel maintained in the temperature range of 320-410°C. In the case of sodium benzenesulphonate, a 96% theory-yield of sodium phenate is claimed with a reaction period of about 30 minutes.

(b) Increasing attention has been paid during the last few years to new and non-classical methods of manufacturing phenol. Of these methods depending upon alkali hydrolysis of chlorobenzene have been fully discussed in the article on carbolic acid; three other methods, however, call for brief discussion, their success depending as much upon sound chemical engineering as upon their chemistry.

(i) The first method (B.P. 387832; 410331; cf. U.S.P. 2138609) depends upon the steam hydrolysis of chlorobenzene at atmospheric pressure. The process was worked in Germany for several years after the beginning of the 1939 war, and since 1940, on a much larger scale, in the U.S.A., where about 15,000,000 lb. of phenol per annum were produced (Chem. Met. Eng. 1940, 770; 1945, 107; Ind. Eng. Chem. 1941, 33, 278). In brief, the reaction is carried out in two stages. In stage (1), benzene vapour is partially chlorinated catalytically by hydrochloric acid and air in an exothermic reaction taking place at about 210°C. thus:



About 10% of the benzene is chlorinated per pass to monochlorobenzene, while a very small

percentage is chlorinated to di- and higher chlorobenzenes which form practically the only by-products of the process. The benzene-chlorobenzene-water mixture is fractionated, giving benzene as the overhead, which returns to the chlorination stage, and chlorobenzenes as still residue, which, after fractional distillation, is passed (stage 2) in vapour form with the water obtained in stage (1) over a hydrolysis catalyst at about 400° where by part is hydrolysed thus:

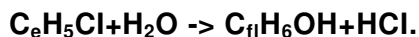

Phenol for sale is separated by distillation, the acid formed goes back to stage (1) and the unchanged chlorobenzene is returned to stage (2). To render the process economic, highly efficient heat exchange is necessary, while the corrosion problem involved in handling wet hydrochloric acid gas is overcome by using, to a large extent, brick-lined and earthenware equipment with tantalum coils for steam heating.

(ii) The second process (Canad. P. 391844; U.S.P. 2223383; 2303658; 2328920; 2382944; see also Newitt and Burgoyne, Proc. Roy. Soc. 1936, A, 153, 448) involves the direct air oxidation of benzene in vapour phase at pressures near atmospheric, by passing the reactants, air-benzene mixture, into a chamber kept at about 800°, with its walls specially coated to eliminate catalytic effects. Only partial reaction is accomplished per pass, and after separating the phenol produced the unreacted benzene is recycled. This process is still in its initial stages, and further developments should be interesting, especially in view of the fact that a most recent development of the method (J.S.P. 2382148), claims that using iodine as a catalyst the yield of phenol on benzene consumed can be raised from about 40% without catalyst to about 56% theory with catalyst.

(iii) The third and last process to be mentioned (U.S.P. 2321551) is unlike any other synthetic method so far described, and depends upon a hydrogen exchange reaction, cyclohexane, which can be obtained by the catalytic hydrogenation of benzene, is oxidised in the presence of a cobalt acetate catalyst at around 173°/30 atm. to give a mixture of cyclohexanol and cyclohexanone.

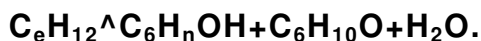

The cyclohexanol-cyclohexanone reaction product is then caused to undergo hydrogen exchange reactions by mixing it with benzene and flowing the mixture through a converter containing a nickel catalyst (which acts as a hydrogenation and dehydrogenation catalyst) under an autogenously-developed hydrogen pressure of 30 atm., and at about 250°C. The reaction product is a mixture of phenol, cyclohexanol, cyclohexanone, cyclohexane, and benzene, which is separated by fractional distillation. The cyclohexane, cyclohexanol, cyclohexanone, and benzene are recirculated with suitable reactant make-up. The overall result is the indirect oxidation of benzene to phenol, the yield of which is stated to be 863 g. from 277 g. cyclohexane and 623 g. benzene, which is equivalent to 81.3% theory overall on the hydrocarbons

consumed. The inventor states that the hydrogen exchange reaction can be carried out in two steps involving endo- and exo-thermic reactions, which practically balance out. The overall reaction thus requires little or no external heat. Accepting the yield mentioned in the patent as being obtainable on the large scale, it would appear that this process is economically feasible, and, in the writer's opinion, further developments are to be expected.

Uses.

In addition to the uses detailed in the earlier article on carbolic acid, considerable phenol tonnage is chlorinated to tri-, tetra-, and pentachlorophenol; 2:4:6-trichlorophenol has marked preservative and fungicidal properties, while the tetra- and penta-chlorophenols are even more antibiotic and, being nearly insoluble in water and possessing very low volatility at room temperatures, have great value for outdoor wood and fabric preservation. The free phenols are usually applied in an oil solution, but aqueous solutions of the sodium salt of tetra- and pentachlorophenol are largely used for dipping freshly-sawn wood in Scandinavia, U.S.A., and Canada; acids in the wood cause deposition of free phenols in the wood structure, which effectively prevent attack by sapstain organisms, various wood-rotting organisms, and certain insects. For a detailed account of pentachlorophenol, free and as sodium salt, see Carswell and Nason, Ind. Eng. Chem. 1938, 30, 622. Certain chlorophenol and chlorophenol homologue derivatives, namely chlorophenoxyacetic acids, have recently found considerable application in synthetic plant hormones which cause pathogenetic fruit formation and which form the basis of certain selective weed killers.

One new and substantial use, and one which should largely increase during the next decade, is as a raw material for "Atycro" production, in which phenol is reduced catalytically by hydrogen to cyclohexanol, from which adipic acid is made, and which, by further condensation with hexamethylenediamine, produces "Nylon" (v. Vol. IV, 125c).

Production.

Few reliable figures are available for phenol production in this country, but the following, relating to natural (coal tar) phenol production during the years 1942, 1943, and 1944, taken from the Ministry of Fuel and Power (Statistical Digest 1944, Cmd. 6639) will be of interest:

Year . . . .	1943	1944	1945
Production, in tons.	8,200	8,700	9,200

Corresponding figures for synthetic phenol production can be given, but it is considered to amount to a substantial fraction of the natural product.

Far more data are published relating to U.S.A. manufacture, and figures showing the trend during the past thirty years (U.S. Tariff Commission Reports Nos. 131, 136, 140; 148; Preliminary Reports on Production and Sales of Synthetic Organic Chemicals, 1944, 1946; Chemistry of Coal Utilisation, Chapman and

Hall, 1945, Vol. II, pp. 1346-1346) are given in round numbers in tabular form below:

Year.	Total phenol production in millions of lb.	Period.
1914	1	First World War.
1916	65	
1918	108	Peace.
1919	1	
1923	3	
1925	15	
1927	8	
1929	25	
1932	14	
1934	45	
1935	43	
1937	66	
1938	44	
1940	69	Peace.
1944	202	
1946	f 184 (synthetic) 20 (natural)	

It may be mentioned that Natural Phenol, 1,000,000 lb., accounted for the whole production in 1914; the figure for Natural Phenol production in 1944 had risen to 29,000,000 lb., but this substantial increase is completely overshadowed by the vast developments in synthetic phenol production, rising from nil in 1914 to 173,000,000 lb. in 1944. It is of interest also to note that the increased production in the First World War was mainly due to its use in explosive (picric acid) manufacture, whereas, in the Second World War, the increase was associated with a large increased use as a basic raw material for synthetic resin manufacture, and by a large new use in the recently established "Nylon" industry. In 1944, the average U.S.A. price for synthetic phenol was 0.10 dollars per lb. and for natural phenol 0.09 dollars, as compared with about double the first figure in this country. The greater part of the higher cost in this country is undoubtedly due to the much smaller scale of working, but part appears to be due to the use of less efficient manufacturing methods and, in addition in the case of synthetic phenol, to the high basic production-cost of benzene.

#### THE CRESOLS.

Coal tar forms the main source of these phenols, which have been dealt with at length in the earlier articles on CBESOL (Vol. III, 4246) and CBESYLIO ACID (Vol. III, 4266); supplementary information only is given here.

#### o-Cresol.

##### Manufacture.

As is the case with phenol, continuous vacuum fractionation can be used instead of batch fractionation for separating an o-cresol-rich fraction from the residue remaining after phenol recovery from tar-acid mixtures.

#### m- and p-Cresols.

##### Manufacture.

The separation of m- and p-cresols from coal tar cresols-distillate fractions still continues to engage attention, indicating that the earlier processes are subject to certain chemical or

economic limitations. Undoubtedly the uses of these cresols would be considerably expended if methods of manufacture were available giving the pure isomers at a cost comparable with that of phenol.

(i) Carswell (U.S.P. 2042331) proposed a method of separation depending upon the fact that ra-cresol and phenol form a crystalline compound even in the presence of p-cresol (*cf.* Dawson and Mountford, J.C.S. 1918, 113, 923, 935; *cf.* Kendall and Beaver, J. Amer. Chem. Soc. 1921, 43, 1853). Carswell adds phenol in amount necessary to form the compound in a m-, p-cresol fraction, cools, separates off the crystalline compound, and resolves it by fractional distillation. From the mother liquors, a cresol is said to be obtainable by refrigeration.

(ii) Weinrich (Ind. Eng. Chem. 19/13, 35, 264) and Stevens (*ibid.*, p. 653; *cf.* U.S.P. 2290602; 2297588; 2327938) give details of a rather novel method of separation involving dibutylation, separation of the butylated cresols by fractional distillation, and finally debutylation to give pure m- and p-cresols. A somewhat similar method is described in B.P. 557519.

(iii) It has been proposed to manufacture p-cresol synthetically by a sulphonation-alkali fusion process from toluene analogous to the phenol process from benzene but, as far as is known, without commercial success. Recently (B.P. 518450) difficulties inherent in this method are pointed out, and an improved process claimed, in which sodium o-toluenesulphonate is fused along with another arylsulphonate such as sodium benzenesulphonate. From the fusion product, a mixture of phenol and p-cresol results which can be separated by fractional distillation. No yield figures are given, but if it should be possible to get yields comparable with those of phenol from benzene, and if a large-scale usage of p-cresol developed, this method would enable p-cresol to be produced at a price not much higher than that of phenol.

It has been proposed to manufacture m-cresol synthetically from either o- or p-chlorotoluene by vapour-phase hydrolysis with steam at 400-650°C. in the presence of a suitable hydrolytic catalyst (Shreve and Marsel, Ind. Eng. Chem. 1946, 88, 254). During, or after, the hydrolysis, rearrangement of the hydroxy-substituents in the benzene ring from the ortho- or para-position to the more stable meta-position must occur, a rearrangement which is by no means uncommon (*cf.* Baddeley, B.P. 555751; J.C.S. 1943, 527). Nothing is known, as yet, of large-scale developments of this method.

#### Analytical Methods.

Harrison (J.S.C.I. 1943, 62, 119; *ibid.* 1944, 63, 347) gives details of the application of the Spekter absorptiometer to cresol-mixture analysis, depending upon the use of this instrument to measure the intensity of colour developed by these phenols when treated with Millon reagent. The method is said to give satisfactory results and to be reasonably rapid. Thompson and Whiffin (J.C.S. 1945, 268) have given details of a method for the rapid and accurate analysis of cresol mixtures based on infra-red spectra measurements in ethoxyhexane

solutions, phenol can be detected in cresol mixture?\* and data given indicates that the method is capable of application to the analysis of xylenols-ethylphenol mixtures. With the exception of the cineole method for o-cresol, present-day methods for accurate estimation of phenol and the other cresols are, in general, slow, and in the case of xylene mixtures practically non-existent, so that the importance of the new technique is obvious ^

#### Uses.

The main uses have been detailed in the earlier articles on cresol and cresylic acid ( $q.v.$ ), from which it will be seen that the pure isomers, especially the meta- and para- isomers, are mainly used in small-scale speciality products. A greatly extended use in synthetic resin manufacture can be envisaged, and when they become available in large quantities, at a price comparable with that of phenol. The resins derived from m-cresol are in many ways comparable with those from phenol, while valuable oil-soluble resins can be manufactured from p-cresol.

#### Production.

No production data are available in this country, but figures for the U.S.A. taken from the same source as those given for synthetic phenol show that the production of o-cresol in round numbers in millions of pounds in 1942, 1943, and 1944 were 1, 4, and 4 respectively, the price dropping concomitantly with increase in production from 0-15 to 0-13 dollars per lb. No figures are published for m- and p-cresol here or in the U.S.A., but it is clear from their known uses that these must be very small in each case as compared with those, for phenol or cresol mixtures.

#### THE XYLENOLS.

The xylenols (dimethylphenols) form, together with m-, p-cresol and the ethylphenols, a considerable proportion of the phenols fraction from coal tar boiling in the range 200-230°C. (Raschig, *Z. angew. Chem.* 1912, 25, 1939; Brücker, *ibid.* 1928, 41, 1043, 1062) and, up to recently, this fraction has constituted the sole source of such xylenols as have been prepared in pure form in any quantity. A considerable amount of ingenuity and time has been expended in trying to develop methods for the economic separation of pure xylenols from the fraction containing them, such as: (i) The separation of 2:5- and 2:4-dimethylhydroxybenzene from the tar-acid fraction b.p. ca. 211°C. by sulphonation and crystallisation of the sulphonic acid of the 2:5-(p) xylene from the mixture, and of the potassium salt of the sulphonic acid of the 2:4-xylene from the residue, followed in both cases by steam hydrolysis to give the free phenols, (ii) The separation of the 2:5-xylene from the fraction b.p. 210-212°C. by sulphonation and crystallisation of its ammonium sulphonate (Morgan and Pettet, B.P. 397148). (iii) The separation of various xylenols from mixtures by forming additive compounds from them with bases such as benzidine (Bentley and Catlow, B.P. 374010; cf. U.S.P. 1980901). (iv) Separation by alkylation such as butylation, followed by fractiona-

tion of the alkylated mixture, and dealkylation in a manner analogous to the similar method proposed for separating m-o-cresol mixtures (Luten and Benedictis, B.P. 557519; cf. U.S.P. 2290602; 2297588). The methods mentioned have not as yet been commercially exploited on any considerable scale.

#### m-Xylenol, s/m.-m-xylene, 3:5-dimethyl-1-hydroxybenzene.

This is the most abundant xylene present in coal tar (Raschig, *l.c.*) and the only xylene manufactured in substantial amount from the xylenols fraction of coal tar.

#### Manufacture.

It is obtained by fractional distillation of a xylene mixture followed by crystallisation, or solvent crystallisation, of the fraction b.p. 217-222°C. (Kester, *J. Ind. Eng. Chem.* 1922, 24, 770; "Chemistry of Coal Utilisation," Chapman and Hall, 1945, Vol. II, M, 1347).

Recently a new synthetic method has been disclosed by Williams and Ballard (U.S.P. 2369196) in which isophorone, a 3:5:5-trialkylmonocyclic aliphatic ketone, is subjected to pyrolysis at 575-700°C. under controlled conditions, giving up to 40% yields of the xylene. This reaction is applicable to 3:5-dialkylphenols in general, and since the ketones are apparently obtained from petroleum products, the method appears to offer a low-priced route to such phenols. Baddeley (*J.C.S.* 1943, 527) shows that under treatment under controlled conditions with aluminium chloride, xylenols and other substituted phenols tend to undergo interconversion to the more stable meta-substituted forms; in B.P. 555751 he claims a process for manufacturing 3:5-xylene based on this work.

#### Production and Uses.

No production figures are available. The main use of the xylene is as the source of its p-chloro-derivative, which finds very considerable application in the preservative and disinfectant field. The phenol has also been found of considerable use in the synthetic resin field, but this application is hampered by its relatively high price and its strictly limited availability, although the synthetic routes to its manufacture mentioned above promise to increase the availability.

#### BUTYLPHENOLS.

One only, p-tert-butyl phenol is industrially important.

#### Manufacture.

There are several possible methods of preparation from phenol and isobutyl alcohol or tert-butyl chloride, and by rearrangement of phenyl tert-butyl ether, for details of which see Liebmann (*Ber.* 1881, 14, 1842; *ibid.* 1882, 15, 150; G.P. 17311); Lewis (*J.C.S.* 1903, 88, 329); Curewitsch (*Ber.* 1905, 38, 2428); Hartmann and Gattermann (*ibid.* 1890, 23, 3332); Smith (*J. Amer. Chem. Soc.* 1933, 55, 3701); B.P. 409131; U.S.P. 1972599; 1991332; Tsukervanik and Nazarova (*J. Gen. Chem. Russ.*



1935, 5, -767); Huston and Hsieh (J. Amer. Chem. Soc. 1936, 58, 439); U.S.P. 2039344; 2091565. The most economic methods of manufacturing the phenol on the large scale, and probably the ones which are used to produce the bulk of the phenol, are those involving the reaction of phenol and di-*n*-butylene (U.S.P. 2091565) or the reaction of phenol and *iso*-butylene (U.S.P. 1892990) in the presence of aluminium chloride. In the former case, 60 mol. of phenol and 1 mol. of aluminium chloride are stirred, and 20 mol. of di-*isobutylene* slowly added at about 85°C. The temperature is raised to 120°C., the mixture cooled and neutralised with sodium carbonate solution and, after filtration, vacuum fractionally distilled to give a first fraction of phenol which can be re-used, and a residue of the butylphenol. In effect, in this method of manufacture, the di-*n*-butylene molecule depolymerises either during or after condensation with the phenol. Actually it is possible by reaction of di-*n*-butylene with phenol under suitable conditions (B.P. 409111) to get *di-isobutylphenol* which can be converted by the action of aluminium chloride (Smith and Bodden, J. Amer. Chem. Soc. 1937, 59, 2353) into *p*-*tert*-butylphenol. Other methods of manufacture from *isobutylene* or di-*isobutylene* and phenol, using sulphuric acid catalyst, have been proposed (B.P. 420636; 452335). It may be mentioned that *isobutylene* and di-*n*-butylene are obtained in bulk and at relatively low prices in petroleum refineries, which explains why methods of manufacture using these products are more economic than those utilising the much more expensive *tert*-butyl alcohol, or chloride.

#### Production and Uses.

Although no figures can be given it is known that *p*-*tert*-butylphenol is manufactured in very substantial and probably increasing amounts, especially in the U.S.A.; it is significant that the U.S.A. production of unmodified *p*-*tert*-butylphenol-formaldehyde resins amounted to 3.3 million pounds in 1946. These resins on dissolving in unsaturated oils, such as tung oil, followed by suitable heat treatment, condense with constituents of the tung oil, giving varnish (coating) bases having extremely valuable properties (B.P. 334572; 417222; 426249). The phenol has also useful disinfectant properties and has been proposed for use in disinfectant preparations (B.P. 484228).

#### OCTYLPHENOLS.

A considerable amount of work has been done on one octylphenol, *p*-di-*n*-butylphenol, or *p*-tetramethylbutylphenol (Nietferl, Ind. Eng. Chem. 1938, 30, 1267-74) which is obtained by reaction between phenol and *diisobutylene* in the presence of a small amount of sulphuric acid (B.P. 409111). A whole series of derivatives is described, some of which are patented for use as germicides, disinfectants, plasticisers, photographic developers, wetting and tanning agents. For further details, see U.S.P. 2008032; 2029539; 2073316; B.P. 431487; Niederl, I.e.

#### TRIMETHYLPHENOLS.

One of the isomeric trimethylphenols; namely 2:3:5-trimethylphenol, or cuminol, has recently been separated from crude phenol mixtures obtained from coal tar or cracked petroleum distillates by close fractional distillation and static crystallisation of the fractions, b.p. ca. 235°C. The crude phenol so obtained is purified by repeated crystallisation from suitable solvents such as *n*-propyl alcohol, or ether (B.P. 561738). The phenol is of considerable interest because it can be easily converted by oxidation to its quinone, 2:3:5-trimethylhydroquinone which, on reaction with phytyl bromide, gives alpha-tocopherol, which is one of the most potent of the vitamin-A group. The isolation of the 2:3:5-trimethylphenol from phenolic mixtures, such as those mentioned, should enable this vitamin to be manufactured much more conveniently than has been hitherto possible.

#### METHYLPROPYLPHENOLS.

Two only are of industrial importance, namely thymol, \* 3-methyl-6-isopropylphenol and carvacrol, 2-methyl-5-*n*-propylphenol.

#### Thymol.

The more important of the two phenols occurs naturally in various essential oils including those of Ajowan, Ocimum, Viride, Monarda, Punctata, *Origanum floribundum*, *Thymus capitatus*, and Thyme. In fact, Ajowan oils contain over 50% thymol, and substantial amounts of the phenol are\* obtained by washing this oil with caustic soda of about 10% concentration, and then obtaining the phenol from the alkali solution by methods quite similar to those used in obtaining carbolic acid (*q.v.*) from coal-tar distillates.

Synthetic thymol is manufactured by several methods, the most important being:

(i) From *m*-cresol by condensation with *isopropyl* alcohol or chloride or with propylene. For details of typical methods, see B.P. 551624; U.S.P. 2103736; 2286953; Chemical Trade Journal, 1936, 99, 387.

(ii) Of less importance is an older synthetic method of preparation from cymene by nitration, reduction and diazotisation with replacement of the diazo-group by hydroxyl.

#### Carvacrol.

Like thymol, also occurs in several essential oils, such as those of *Origanum hirtum*, *Montana*, *Thymus serpyllum*, and *Monarda fistulosa*. Oil of *Origanum* contains up to 80% of carvacrol which is obtained on a commercial scale from this oil by alkali washing, as in the case of thymol.

Synthetic carvacrol is also manufactured to some extent by sulphonating *p*-cymene, followed by alkali fusion of the sulphonic acid.

#### Uses.

Both carvacrol and thymol have very useful bactericidal properties, as also have their

chloro-derivatives. The phenols and these derivatives have therefore found limited applications as the bases of speciality antiseptic and disinfectant preparations in the pharmaceutical field. As an indication of their relative industrial importance compared with other phenols, it may be mentioned that the United States production of thymol in 1942 amounted

to 110,476 lb., the average selling price being 2-32 dollars per lb.

**B. THE DIHYDRIC PHENOLS.**

*Physical Constants.*—Useful physical constants for the lower members of the series are tabulated below.

Phenol.	M. p. or c. p., °C.	B. P., °C./760*mm.	Density, g. per ml. at 20°.
Catechol, 1:2-dihydroxybenzene	105 (i)	245(2)	1-344/4(3)
Homocatechol, 1:2-dihydroxy-3-methylbenzene		241 (s)	—
Homocatechol, 1:2-dihydroxy-4-methylbenzene	65(9)	251 (s)	—
1:2-Dihydroxy-4:5-dimethylbenzene		—	—
1:2-Dihydroxy-3:5-dimethylbenzene		—	—
Resorcinol, 1:3-dihydroxybenzene	126-5-128-0 (12)	280-8 (5)	1-2728/0 (s)
Resorcinol, 1:3-dihydroxy-4-methylbenzene	116-121 (3)	267-270 (11)	—
Orcinol, 1:3-dihydroxy-5-methylbenzene	146-147 (s)	287-290 (11)	—
2-Methylresorcinol, 1:3-dihydroxy-2-methylbenzene	136-137 (s)	—	—
1:3-Dihydroxy-2:4-dimethylbenzene	124-5-1250 (1s)	276-279 (is)	—
1:3-Dihydroxy-4:5-dimethylbenzene	172(1); 170-3 (?)	285/730 (2)	1-324-8/4(3)
m-Xylorcin, 1:3-dihydroxy-4:6-dimethylbenzene		—	—
Hydroquinone, 1:4-dihydroxybenzene	124-125 (12)	—	—
Toluhydroquinone, 1:4-dihydroxy-5-methylbenzene	170 (20)	—	—
1:4-Dihydroxy-2:5-dimethylbenzene	217 (21)	—	—
1:4-Dihydroxy-2:6-dimethylbenzene		—	—

- (a) Form stable above 70-8°o.
- (b) Form stable below 70-8°c.
- i Kempf, J. pr. Ghem. 1908, [iii], 78, 236, 256, 257.
- z Grabe, Annalen, 1889, 254, 296 (ann.).
- z Schroder, Ber. 1880, 12, 563.
- z Lautz, Ph. Ch. 1913, 84, 611.
- z Herzig, Wenzel, and Halsler, Monatsh. 1903, 24, 906.
- z Calderon, Bull. Soc. chim. 1873, [iii], 29, 234.
- z Hartley and Little, J.C.S. 1911, 09, 1081.
- z Limpach, Ber. 1891, 24, 4137.
- z Pauly, *ibid.* 1909, 42, 422.

- 10 Wallach, Ber. 1862, 15, 2835.
- 11 Knecht, Annalen, 1882, 215, 93.
- 12 Nevile and Winther, Ber. 1882, 15, 2979, 2989.
- 13 Dumas, Annalen, 1833, 27, 143.
- " Diepolder, Ber. 1911, 45, 2501.
- is Hodgkinson and Limpach, J.G.S. 1893, 63, 108.
- is Wischen, Ber. 1890, 3, 3114.
- is Simon, Annalen, 1903, 329, 305.
- 18 Pfaff, Ber. 1883, 16, 1138.
- 19 Kostanecki, *ibid.* 1886, 19, 2323.
- 20 Bamberger and Rising, Annalen, 1901, 318, 302.
- 21 Bamberger and Blangry, *ibid.* 1911, 384, 291.

**Catechol.**

This substance, o-dihydroxybenzene, also called *pyrocatechol* (v. Vol. II, 429c), is the least industrially important of the dihydric phenols, but of recent years interesting new uses and applications of the phenol and its derivatives have been found.

**Manufacture.**

Undoubtedly, methods of manufacture showing promise of producing catechol at a reasonably low price are those based on the alkaline pressure-hydrolysis of o-dichlorobenzene and of o-chlorophenol, and it is considered probable that the main part of the world's catechol is made in this manner, especially in the U.S.A. After hydrolysis, the cooled charge is acidified and the catechol obtained by solvent extraction and distillation. The following references are pertinent: U.S.P. 1970364; 2001014; 2041592; 2126648; B.P. 425230. A further manufacturing method which may have possibilities is that from safrole (Teikiche Hiraidzumi, J. Chem. Soc. Japan, 1934, 55, 601).

**Uses.**

Catechol and its derivatives may be used as antioxidants for preventing the oxidation of fats

and oils with consequent development of rancidity, and also for inhibiting oxidation of other organic products (B.P. 344690; U.S.P. 2124749; Tattersfield, Analyst, 1932, 57, 401; Light and Barry, Official Printing Ink Maker, 4, No. 3, 10, 22, 24). They are also used in the manufacture of azo-dyes suitable for dyeing leather yellow or brown.

Alkylated catechols have pronounced germicidal properties, hoxyocatechol being more potent than hexylresorcinol (U.S.P. 2067452). The monoethers also have bactericidal properties (Klarman *et al.* J. Amer. Soc. 1932, 54, 1204-1211).

Catechol forms the basis of really excellent developers but probably owing to its relatively high cost has not been used to the extent that might be expected (Eder, Phot. Korr. 1933, 69, 172). More recently, catechol has been used in the form of its double compound with p-phenylenediamine as the basis for fine-grain developers (B.P. 466626).

**Resorcinol.**

Resorcinol, m-dihydroxybenzene, is formed when certain resins, e.g., Asafoetida, Galbanum\* are heated with potash, or when Brazil wood extracts are distilled, but such methods of preparation are of no commercial interest.

*Manufacture.*

The only method of importance is that based upon the disulphonation of benzene to the *m*-disulphonic acid which is neutralised to give its sodium salt. This is fused with excess caustic soda at about 320°C., giving the disodium salt of resorcinol, and sodium sulphite, from which crude resorcinol is obtained by solution in water, acidification, and ether extraction. After removal of the solvent by distillation, the crude product is vacuum distilled and, if required, further purified by sublimation for pharmaceutical usage. Brief details of this method as worked in Germany at the Hoechst I.G. Works are as follows: 600 weight parts of benzene are heated with stirring at about 50°C. with 1,500 parts 100% sulphuric acid and the mixture heated to 100°C. to complete the sulphonation to benzene-monosulphonic acid. The sulphonation product is run slowly into 2,050 weight parts of 65% oleum at 30°C. rising to 80°C. with stirring, whereby benzene-*m*-disulphonic acid is formed. The reaction mixture is run into sodium sulphate solution, containing sodium sulphate equivalent in amount to the disulphonic acid, and the mixture neutralised with lime slurry and filtered from the calcium sulphate precipitated. Small amounts of calcium salts remaining in solution are removed by treatment with a little sodium carbonate followed by filtration. The resulting solution of disodium sulphonate is evaporated to dryness to give a 98% theory yield on benzene of the dry salt, 800 weight parts of which are fused with 500 weight parts of caustic soda at a temperature rising to 340°C. The fusion product is stirred with water, sodium sulphite left undissolved separated by filtration, and the filtrate neutralised with hydrochloric acid and extracted with ether. After removal of the ether, the crude resorcinol left is vacuum distilled to give technically pure product in approximately 85% theory yield (File F.D. 4409/45, Folder B., Hoechst Werk, Foreign Documents Unit).

For further details of manufacturing or proposed manufacturing methods, see

(i) Sulphonation and disulphonation of benzene: Kosner and Monsilise (Ber. 1879, 9, 583); Engli (*ibid.* 1878, 8, 817; Aylsworth (U.S.P. 1260852); Downs (U.S.P. 1279295; 1279296); Senseman (J. Ind. Eng. Chem. 1921, 13, 1124); Ambler and Cotton (*ibid.* 1920, 12, 968); Weiss (U.S.P. 1547186); Cotton (U.S.P. 1915925); Carr and Dahlen (U.S.P. 1999955; 2007327); Hauser and Korovetzkaja (Mem. Inst. Ghem. Tech. Ukraine Acad. Sci. 1938, No. 9, 135).

(ii) Fusion\* of *m*-benzenedisulphonic acid with alkali and working up to resorcinol: Boswell and Dickson (J. Amer. Chem. Soc. 1916, 88, 1786); Goodman and Grubman (U.S.P. 1314138); Phillips and Gifcs (J. Ind. Eng. Chem. 1920, 12, 857); Downs (U.S.P. 1658230); Volujnkin (J. Appl. Chem. Russia, 1936, 9, 885); Burroughs (U.S.P. 2043232); Kaminskii (Org. Ind. U.S.S.R. 1939, 6, 364).

*Uses.*

Of the dihydric phenols, resorcinol is industrially second to hydroquinone in importance, and is used in considerable amount, but reliable quantitative data on usage are not published.

Resorcinol is used to a considerable extent as one of the intermediates in certain Azo Alizarin, Coomassie union blacks, Cyanin, Eosin, Oxazine, Pyrimidine, Stilbine, and Sulphur dyestuffs.

Formaldehyde-resorcinol resins find appreciable use as adhesives in the plywood industry. The resins are also useful as impregnants for paper-board and products made therefrom.

Resorcinol itself is used in dermatology as also is the monoacetate. Hexylresorcinol has marked germicidal properties and finds some application in certain speciality germicides.

The monoacetate is useful in increasing low temperature resistance of cellulose acetate plastics while the diacetate can be used as a plasticiser for nitrocellulose.

**Hydroquinone.**

Hydroquinone, *p*-dihydroxybenzene, occurs naturally combined with glucose in the glycoside arbutin, and as its monomethyl ether in the glycoside methylarbutin (v. Vol. VI, 86a). It is also obtained when quinic acid is dry distilled, or treated in an aqueous solution with lead dioxide (Wohler, Annalen, 1848, 65, "349). No useful natural source of the phenol exists, and, accordingly, the demands of industry are met by synthetic production.

*Manufacture.*

Aniline is the usual starting material for hydroquinone production, although more recently it has been proposed to prepare the phenol by electrolytic oxidation of benzene, or by alkaline hydrolysis of *p*-bromophenol.

(i) From aniline: Aniline is oxidised in sulphuric acid solution with manganese dioxide or sodium dichromate, giving quinone which on reduction with sulphur dioxide or iron gives hydroquinone,

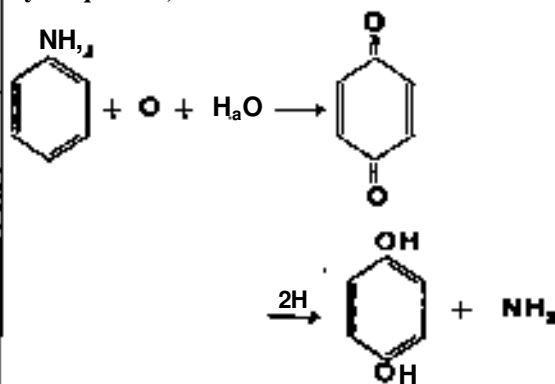

Of the two oxidising agents, manganese dioxide is the more important, and a typical manufacturing method as worked in Germany (C.I.O.S. Report No. 22, File No. XXVII-50, published for Board of Trade by H.M. Stationery Office, 1946; Chem. Trade J. 1946, 465; cf. U.S.P. 2043912) may be summarised thus:

Into a stirred mixture of 2,000 l. of 60°Bé sulphuric acid cooled to 3°C. approx. 470 kg. of pyrolusite containing about 80% MnO<sub>2</sub> are added, the mixture being again cooled to 3°C. 500 Kg. aniline as sulphate solution of specific gravity 12-14° Bé., at 30-35°C. are added over a period of about 1 hour, when 930 kg. of the pyrolusite (i.e., 1,400 kg. in all; 120% of theory)

are added, the temperature being kept at 3-10° for the reaction period of 11-12 hours. The reaction mixture is steam distilled, giving quinone in crystalline form of 99-100% purity. The quinone is reduced by means of finely ground metallic iron in stirred, neutral, aqueous solution. After reduction, the reaction mixture is heated to 80°c, filtered, and technically pure hydroquinone recovered from the filtrate by evaporation in a triple-stage vacuum-evaporator, with final drying on a drum dryer. Further purification is by vacuum distillation, followed by crystallisation. The yield of technically pure hydroquinone is about 84% theory which on further refining gives 88-91% of purified product.

For a method using dichromate as the oxidising agent, see Austral. P. 9814£.

(ii) From benzene: B.P. 430572 and 556166 claim to manufacture hydroquinone by electrolytic oxidation of benzene to quinone which is reduced by iron or sulphur dioxide to hydroquinone. Benzene is added continuously to 10% sulphuric acid in an undivided electrolytic cell having a PbO<sub>2</sub>/Pb, or Pb/Sb, or Pb/Be alloy anode and a smaller water-cooled lead cathode. The quinone produced by electrolytic oxidation is extracted by the benzene continuously flowing through the cell and the dilute quinone solution passes to a reduction cell containing water and the reducing agent kept above the boiling-point of benzene. Benzene distils continuously and is returned to the electrolytic cell, while the quinone passes into the aqueous phase and is reduced to hydroquinone.

(iii) From p-bromophenol: U.S.P. 1934656 claims the manufacture of hydroquinone by hydrolysis of p-bromophenol in aqueous 5-15% caustic soda solution at 70-150°c. in the presence of copper or cuprous oxide catalyst.

For further details of manufacture of hydroquinone and its purification, see Thatcher (Trans. Amer. Electrochem. Soc. 1919, 36, preprint); Sladek (Casoas, Ceskoslovenskeho, Lekarnictva, 1927, 7, 299; B.P. 174554; 430572; 455692; U.S.P. 1318631; 1322580; 1421869; 1880534; 1883284; 1943656; 1998177; 2006324; 2041592; 2066951; 2129429; 2130151.

Production,

Hydroquinone is manufactured in two main grades: (1) The technically pure product used in industry for purposes other than photographic, and (2) a purer product known as the photographic grade used mainly in the photographic industry. Figures are not published relating to production in this country, but such production is small compared with that of the U.S.A. for which production figures, together with average selling price for recent years, are tabulated below. (Source as given for phenol.)

Grade.	Yearly production in millions of pounds (and price in dollars).		
	1942.	1943.	1944.
Photographic	3.00 (0.67)	2.66 (0.65)	1.0 (0.86)
Technical.	—	3.03 (0.59)	3.65 (0.56)

Uses.

The largest single use is undoubtedly in photography (q.v.), where it forms the basis of the universally used metol-quinol (MQ) developer, the greater proportion of which is absorbed by the cine-film industry. The chloro- and bromo-derivatives are also used in photographic developers.

Another very important use of hydroquinone is either as such, or in the form of derivatives such as chloro- mono-ethers and esters, condensation products with p-phenylenediamine, etc., to inhibit oxidation in a wide range of products, including rubber and other plastics, paints and other coating compositions, motor fuel, animal and vegetable oils, waxes, etc. The phenol also finds use in making certain dyestuffs, e.g., quinizarin, and in the manufacture of synthetic pharmaceuticals.

C. THE TRIHYDRIC PHENOLS.

Physical Constants.—Some physical constants of the lower members of this series are tabulated in Table III.

TABLE III.

Phenol.	M.p. or c.p., °O.	B.p., °O.	Density, g. per ml. at °O.
Pyrogallol, 1:2:3-trihydroxybenzene	132.5 (i)	309(2)	1.453/4 (2)
4-Methylpyrogallol, 1:2:3-trihydroxy-4-methylbenzene	140-141 (3)	—	—
5-Methylpyrogallol, 1:2:3-trihydroxy-5-methylbenzene	229(4)	—	—
Oxyhydroquinone, 1:2:4-trihydroxy benzene	140.5 (5)	—	—
3-Methoxyhydroquinone, 1:2:4-trihydroxy-3-methylbenzene	117-118(3)	—	—
5-Methoxy hydroquinone, 1:2:4-trihydroxy-5-methylbenzene	130-131 (6)	—	—
6-Methoxyhydroquinone, 1:2:4-trihydroxy-6-methylbenzene	128-129 (7)	—	—
Phloroglucinol, 1:3:5-trihydroxybenzene	217-219 (8); 117 (a) (9)	—	—
2-Methylphloroglucinol, 1:3:5-trihydroxy-2-methylbenzene	214(W)	—	—

i) M.p. of dihydrate from water.  
 1) Cazeneuve, Compt. rend. 1892, 114, 1486.  
 2) Perkin, J.C. 3, 1896, 69, 1185.  
 3) Majima and Okazaki, Ber. 1916, 49, 1490, 1492.  
 4) Hofmann, *ibid.* 1879, 12, 1376.  
 5) Barth and Schreder, Monatsh. 1884, 6, 592.

6) G.P. 101607.  
 7) Henrich and Nachtigall, Ber. 1903, 36, 894.  
 8) Baeyer, *ibid.* 1886, 19, 2187.  
 9) Will, *ibid.* 1887, 20, 297.  
 10) Boehm, Annalen, 1901, 318, 286.

Of the trihydric phenols only two are of any substantial technical importance at the present time, namely, pyrogallol and phloroglucinol.

### Pyrogallol.

This exists in the form of ethers in certain fractions of Wood Creosote (*v.* Vol. III, 419c), as glycosides of its monocarboxylic acid (gallic acid) in many of the tannins, and free in certain plants and fruits such as aB tea, mangoro, *Caeaalpinia coriaria*.

### Manufacture.

The main and probably only present method of manufacture is from gallic acid (*v.* Vol. V\* 417a) which is autoclaved with half its weight of water at a temperature rising to 175°C. over a period of 3 hours; after cooling, treating with carbon and filtering, the solution is concentrated until nearly all the water has evaporated, then poured into trays and cooled to give solid crude pyrogallol, which is purified by distillation and sublimation {*cf* Braconnet, *Annalen*, 1832, 1, 26; Pelouze, *ibid.* 1834, 10, 159; Laynes and Espernandieu, *Z. angew. Chem.* 1887, 1, 702).

It has been proposed to manufacture synthetic pyrogallol by alkali hydrolysis of 2:6-dichlorophenol-4-sulphonic acid to pyrogallol-5-sulphonic acid, which on heating gives pyrogallol (G.P. 207374) and also by pressure hydrolysis of certain wood creosote fractions (Ugriumov, *Leaokhim Prom.* 1933, 2, No. 3, 19; Sumarokov and Ugriumov, *J. Appl. Chem. Russia*, 1936, 9, 2222; Sumarokov and Stepanova, *ibid.* 1937, 10, 1248). For a discussion of the methods of preparation of pyrogallol, *see also* Schwyzer (*Pharm. Ztg.* 1929, 49, 1), and for purification, Cutrona, McCann, and Bissell (U.S.P. 1434593).

### Production and Uses.

No reliable, production figures are available for manufacture in Europe, but the U.S.A. produced 57,423 lb. in 1942, which was sold at an average of 2.04 dollars per lb., according to the United States Tariff Commission Preliminary Report for 1942, dealing with the Production and Sales of Synthetic Organic Chemicals.

Pyrogallol finds use in quite a large number of rather small-scale speciality fields.

Pharmaceutical chemicals include the mono- and tri-acetates, the\* salicylates, the sulphonic acid sodium salt.

Dyes, *e.g.*, Alizarin and Anthracene Yellows, certain azo dyestuffs such as azogallein, Chrome Brown RR, and some xylonone dyestuffs are manufactured from pyrogallol.

In photography, the phenol is used extensively in this country as the basis of the so-called "Pyro" negative developers\* especially among professional photographers, and "Pyro quality in a negative" is still looked upon as a hallmark of goodness. In the U.S.A. pyro developers are probably not so much used, but the alkyl ethers have been claimed (U.S.P. 2017295) as the basis of developers having little tendency to become oxidised. \*

Antioxidants for petroleum distillates and wax, or wax-like products, *cf* U.S.P. 1752933. Certain alkyl ethers have been proposed for use

as petroleum antioxidants, but<sup>1</sup> have been shown by Schumann and Haslam (*Tfid. Eng. Chem.* 1934, 34, 455) to have no outstanding advantages over other substances in this connection.

### Phloroglucinol.

This occurs in combined form in many glycosides, such as Hesperidin, Quercetin, and Phlorizin, in certain resins<sup>1</sup>, Catechu, Gamboge, Kino, and also in many tannins, and is formed as its potassium salt by fusion of resorcinol with caustic soda.

### Manufacture.

The phenol is made in the relatively small quantity required technically by nitration of benzoic acid to 2:4:6-trinitro-derivative, reduction of this with tin and hydrochloric acid to the stannichloride of triaminobeyttic acid, which on boiling with water loses carbon dioxide and ammonia giving phloroglucinol in aqueous solution from which it is obtained by evaporation and crystallisation (Cassella, G.P. 102358; Flesh, *Monatsh.* 1899, 18, 758; Weidel and Pollak, *ibid.* 1000, 21, 20).

### Uses.

Phloroglucinol finds its main industrial application as a component of developers used in dyeline printing processes; it has to a very small extent found some usage as a decalcifying\* agent for bones, and as an analytical reagent in the determination of pentoses.

### D. THE TETRA-, PENTA-, AND HEXA-HYDRIC PHENOLS.

These phenols have, up to the present, found no industrial application, and for that reason are only briefly mentioned here. When pure, all form colourless crystals, and, with the exception of Apionol, are unstable in air and especially so in aqueous and alkaline solutions, when they undergo oxidation to quinones or other bodies of unknown composition. All the three tetrahydric phenols are known, namely, 1:2:3:4-, 1:2:3:5-, and 1:2:4:5-tetrahydroxybenzene.\*

1:2:3:4-Tetrahydroxybenzene (Apionol) occurs in the form of derivatives in the apionols (*see* articles on essential oils). It has been prepared by hydrolysis of aminopyrogallol hydrochloride (Einhorn *et al.*, *Ber.* 1904, 37, 119) and has m.p. 161°C; *tetra-acetale*, m.p. 142°C; *tetramethyl ether* (Apiol), m.p. 89°C. For further details of this phenol and its derivatives, *see* Ciamician and Silber (*Ber.* 1896, 29, 1808), Wesseley and Lethner (*Monatsh.* 1932, 60, 159).

1:2:3:5-Tetrahydroxybenzene (Oxyphloroglucinol) has been prepared by reduction of picric acid to the triamino-compound and by hydrolysis of this. Will (*Ber.* 1888, 21, 609, 2020; *cf* Posternak, *Helv. Chim. Acta*, 1936, 19, 1937) has prepared the phenol from 2-hydroxy-6-methoxybenzoquinone. The phenol melts at 165-167°C, and on reduction with sodium amalgam gives oxyphloroglucinol. *1-Methyl ether*, m.p. 235°C.; *tribenzoate*, m.p. 103°C. For further details, *see* Grache and Luter (*Annalen*,

1905, 340, 222), Barzellini and Bene (Chem. Zentr. 1911, 1, 392); Postemak (*I.e.*).

1:2:4:5-Tetrahydroxybenzene is conveniently prepared by heating dibromo-1:4-dihydroxyquinone with aqueous potassium sulphite solution. It has no sharp melting-point. *Tetra-acetate*, m.p. 226-227° (Jackson and Biggs, J. Amer. Chem. Soc. 1914, 36, 1216). For further derivatives, see Mulzerji (J.C.S. 1922, 121, 545).

Only one pentahydric phenol, quercitol, 1:2:3:4:5-pentahydroxy benzene, can exist. A compound considered to be this phenol was prepared by Einhorn *et al.* (Ber.-1904, 37, 122) by the hydrolysis of 4:6-diaminopyrogallol hydrochloride. The phenol so obtained had no definite melting-point, and its *penta-acetate* melted at 165° (decomp.) (*cf.* Wenzel and Weidel, Chem. Zentr. 1906, n, 829).

Hexahydroxybenzene, can be easily prepared by the reduction of tetrahydroxyquinone (Bacher and Boan, Bee. trav. chym. 1937, 56, 1161) and also from hydroquinone (Nietzki and Benckiser, Ber. 1885, 18, 499, 1833). The potassium salt is apparently identical with the compound obtained by the action of carbon monoxide on molten potassium (Gmelin, Pogg. Ann. 1825, 4<sup>35</sup>). *Hexa-acetate*, m.p. 222°. On reduction with hydrogen with palladium black catalyst, the phenol gives inositol (Wieland and Wisnar, Ber. 1914, 47, 2084). Several esters are described by Bacher and Boan (*I.e.*).

#### PHENOTHIAZINE.

"Thiodiphenylamine." Anthelmintic (veterinary) (v. SYNTHETIC DRUGS).

W. E. H.

S. E.

PHENYLCACETIC ACID,  $\text{C}_6\text{H}_5\text{CH}_2\text{CO}_2\text{H}$ . Phenylacetic acid, first obtained in 1855 by hydrolysis of benzyl cyanide (Cannizzaro, Annalen, 1855, 96, 247; *see also* Hofmann, Ber. 1874, 7, 519; Mann, *ibid.* 1881, 14, 1645; Staedel, *ibid.* 1886, 19, 1949) is best obtained by this method using sulphuric acid (Organic Syntheses, Coll. Vol. I, 436). It has also been synthesised by reduction of mandelic acid with phosphorus and hydriodic acid (Crum Brown, Z. für Chem. 1865, 443), by decarboxylation of phenylmalonic acid (Wislicenus, Ber. 1894, 27, 1094), by carboxylation of benzylmagnesium chloride (Houben and Kesselkaul, *ibid.* 1902, 35, 2523) and from phenylpyruvic acid with hydrogen peroxide (Mauthner, Annalen, 1909, 370, 371; Sugawara and Tsuda, J. Pharm. Soc. Japan, 1935, 55, 1050).

It has been obtained by baryta hydrolysis of vulpinic acid (Möller and Strecker, Annalen, 1860, 113, 64), by fusion of atropic acid with potassium hydroxide (Kraut, *ibid.* 1868, 148, 242), during putrefactive decomposition of certain proteins (E. and H. Salkowski, Ber. 1879, 12, 649; Z. physiol. Chem. 1878, 2, 420; 1885, 9, 499, 507), in acetone-soluble fat from tubercle bacillus (Stendal, Compt. rend. 1934, 198, 400) and as a hydrolytic product of benzylpenicillin (Nature, 1945, 156, 756).

It crystallises from hot water, forming thin plates, m.p. variously quoted from 76-78°; b.p. 265-6° (corr.), 144-2-144-8°/12 mm. Very easily soluble in alcohol and ether. For ultra-

violet absorption spectra, *see* Baly and Collie (J.C.S. 1905, 87, 1344), Baly and Tryhorn (*ibid.* 1915, 107, 1065), and Guilmart (Bull. Soc. chim. 1938, [v], 5, 1209). Classical dissociation constant,  $5.06 \times 10^{-8}$ ; thermodynamic dissociation constant,  $4.88 \times 10^{-8}$  (Dippy and Williams, J.C.S. 1934, 161; Jeffrey and Vogel, *ibid.* 1934, 166).

Administered to dogs and cats, it is converted to phenylacetyl glycine, and, in humans, hippuric acid is said to be formed (Hotter, J. pr. Chem. 1888, pi], 38, 117) only about 5-7-5% being conjugated with glucuronic acid (Wagreich, Kamin, and Harrow, Proc. Soc. Exp. Biol. Med. 1940, 43, 468). It acts as a plant hormone in low concentrations (*see, e.g.*, Pearse, Nature, 1936, 138, 363), but may retard growth at higher concentrations (Borgström, Bot. Notiser. 1939, 207; Hamner, Bot. Gaz. 1942, 103, 576). The esters are also active (Zimmerman, Hitchcock, and Wilcoxon, Contrib. Boyce Thompson Inst. 1936, 8, 105).

It forms water-insoluble salts with most heavy metals, usually hydrated; the *benzylammonium salt*, m.p. 122-122-6° corr., and a *phenylethylammonium salt*, m.p. 115-6-116-4° corr., are useful for identification.

Methyl ester, b.p. 220°; ethyl ester, b.p. 227°.

**Phenylacetyl chloride**, b.p. 110-105°/16 mm.,

$n_D^{20} = 1.674$ , is most conveniently prepared by the action of thionyl chloride on the acid; on heating with the silver salt or with oxalic acid, **the anhydride**, m.p. 72-5°, is formed. **Phenylacetamide**, best prepared by the action of dry ammonia gas on an ether solution of the chloride, has m.p. 154-155°, b.p. 281-84°; **diethylamide**, m.p. 86°; **diphenylamide**, m.p. 72°; **hydrazide**, m.p. 116°; **benzylamide**, m.p. 122°.

R. B.

PHENYLALANINE, *a-Amino-0-phenylpropionic Acid*,  $\text{C}_6\text{H}_5\text{CH}_2\text{CH}(\text{NH}_2)\text{CO}_2\text{H}$ .

Phenylalanine, first discovered in etiolated seedlings of *Lupinus luteus*, occurs in many other germinating plants (Schulze and Barbieri, Ber. 1879, 12, 1924; 1881, 14, 1785; Schulze, rZ. physiol. Chem. 1888, 12, 405; 1892, 17, 193; 1894, 20, 306; 1896, 22, 411; 1900, 30, 241) and is readily obtained by hydrolysis of many proteins. Its constitution was determined by Schulze, and confirmed by synthesis (Erlenmeyer and Lipp, Ber. 1882, 15, 1006; Annalen, 1883, 219, 186, 194).

It occurs in the fraction of esterified protein hydrolysates, b.p. 130-180°/0.5 mm., being isolated by precipitation with water (Fischer, Z. physiol. Chem. 1901, 33, 412). It is also separated by fractionation of its sparingly water-soluble copper salt (Brazier, Biochem. J. 1930, 24, 1188) or by salting out from protein hydrolysates (Baptist and Robson, *ibid.* 1940, 34, 221) and is quantitatively separated by chromatographic adsorption on charcoal (Wachtel and Cassidy, J. Amer. Chem. Soc. 1943, 65, 665; Schramm and Primosigh, Ber. 1943, 76 [B], 373).

It may be colorimetrically estimated by nitration with nitric-sulphuric acids, reaction of the product with hydroxylamine and ammonia yielding the violet coloured ammonium salt of

3:4 - di-Monitrodihydrobenzoic acid (Kapeller-Adler, *Biochem. Z.* 1932, 252, 185; Brown, *J. Biol. Chem.* 1944, 155, 277), and gravimetrically by reaction with potassium cyanate and xanthidrol, precipitating the xanthylhydantoic acid as silver or barium salt (Fosse, de Graeve, and Thomas, *Gompt. rend.* 1935, 200, 872).

Naturally occurring phenylalanine is SBVO-rotatory,  $\bar{Z}(-)$ , being configurationally related to natural *l*(-) leucine or *l*(+) alanine (Karrer and Kehl, *Helv. Chim. Acta*, 1930, 13, 50; *cf. ibid.* 1926, 9, 301). The synthetic form (*q.v.*) is resolved by fractional crystallisation of the cinchonine salt of the *N*-benzoyl derivative (Fischer and Mouneyrat, *Ber.* 1900, 83, 2383), the brucine salt of the *N*-formyl derivative (Fischer and Schoeller, *Annalen*, 1907, 357, 1), or the strychnine salt of  $\beta$ -phenyl- $\alpha$ -ureidopropionic acid (Dakin and Dudley, *J. Biol. Chem.* 1914, 17, 29). The selective action of yeast on the  $\langle U$ -form yields the *d*-isomer (Ehrlich, *Biochem. Z.* 1908, 8, 438); *B. proteua* attacks the *S*omer, *B. subtilis* attacks both, and *Loctobocillus cosei* utilises the *rf*-isomer (Stokes and Gunnels, *J. Biol. Chem.* 1944, 154, 715). Asymmetric enzymic synthesis has been used to resolve the *cW*-form (Behrens, Doherty, and Bergmann, *ibid.* 1940, 136, 61).  $\wedge$ Phenylalanine has been obtained by acid hydrolysis of tyrocidine (Gordon, Martin, and Synge, *Biochem. J.* 1943, 37, 313).

*l*-Phenylalanine crystallises from water; 100 g. of water dissolve 2.965 g. at 25°, and 4.431 g. at 50° (Dalton and Schmidt, *J. Biol. Chem.* 1935, 109, 241).  $\{t$  has m.p. 283° (con.) (decomp.);  $[a]_D^{25}$   $\wedge$ 35.1° (Fischer and Schoeller, *ibid.*), and a slightly bitter taste. The *hydrochloride* and *hydrobromide* are stable crystalline compounds,  $C_9H_{11}O_2NHX$ . The *ethyl ester*,  $C_8H_{10}N \cdot CO_2Et$ , an oil, forms a crystalline hydrochloride (Fischer and Luniak, *Ber.* 1909, 42, 4752). *M*-formyl compound,  $C_{10}H_{11}O_2N$ , four-sided plates from water, m.p. 167° (corr.),  $[oQ] +75.2^\circ$  (in ethanol). *N*-*p*-toluenesulphonyl derivative,  $C_{16}H_{17}O_4NS$ , m.p. 164-165° (corr.),  $fag?$  -2-12° (in acetone) (Fischer and Lipschitz, *ibid.* 1915, 48, 360; McChesney and Swann, *J. Amer. Chem. Soc.* 1937, 59, 1116).

*d*-Phenylalanine crystallises in plates, m.p. 283-284° (corr.) (decomp.); 1 part dissolves in 35.3 p#rts of water at 16°;  $[cd]_D^{25}$  -35.08° (2% aq. solution);  $[ag] -7.07^\circ$  (3.5% in 18% hydrochloric acid) (Fischer and Mouneyrat, *I.e.*). It has a  $\wedge$ weet taste; the *hydrobromide*,  $C_9H_{11}O_2NHBr$ , forms silky needles from alcohol-ether; the *H*-formyl compound,



needles or plates from water, m.p. 167° (corr.),  $[a]_D^{25}$   $\wedge$ -75.43°, soluble in 145 parts water at 27°; the *N*-benzoyl compound,  $C_{16}H_{15}O_3N$ , colourless needles, m.p. 145-146° (corr.),  $[a]_D^{25}$  -17.1° (in 7% alkaline solution); the *cinchonine salt*, m.p. 180-181°. *Phenyliaocyanate* derivative,  $C_{18}H_{16}O_3N_8$ , has m.p. 180-181° (corr.),  $[a]_D^{25}$   $\wedge$ +61.27° (in 8% alkaline solution);

the *a*-naphthyl*i*Bocyanate,  $C_{22}H_{19}O_3N_8$ , m.p. 150-151°; the *ip*-toluenesulphonyl derivative,  $C_{16}H_{17}O_4NS$ , m.p. 164-165° (corr.),  $[a]_D^{25}$   $\wedge$ +2.30° (in acetone).

(*l*-Phenylalanine, first synthesised from phenylacetaldehyde, via the amino-nitrile, and by reduction and hydrolysis of 2-phenyl-4-benzylidene-oxazolone (Plöchl, *Ber.* 1883, 16, 2815; 1884, 17, 1623.; *see also* Erlenmeyer and Kunlin, *Annalen* 1889, 307, 146, 163). Hydriodic acid and red phosphorus are used for simultaneous reduction and hydrolysis of the intermediate *a*-benzoylaminocinnamic acid (Harington and McCartney, *Biochem. J.* 1927, 21, 852; Lamb and Robson, *ibid.* 1931, 25, 1231).

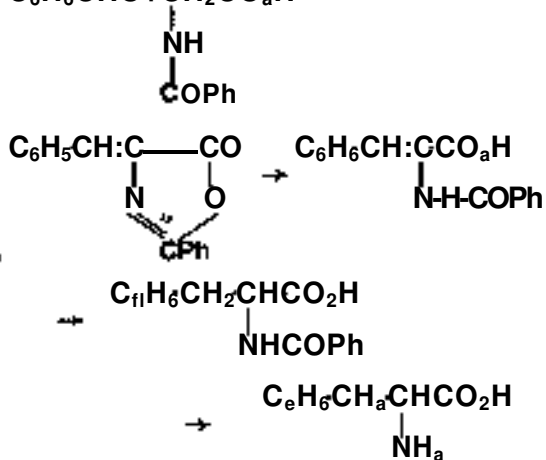
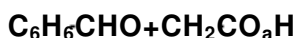

In Fischer's synthesis (*Ber.* 1904, 37, 3062) benzylmalonic acid was brominated, decarboxylated and the  $\alpha$ -bromo- $\beta$ -phenylpropionic acid treated with ammonia (*su Organic Syntheses*, 1941, 21, 99).

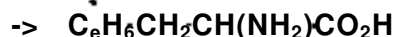
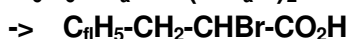
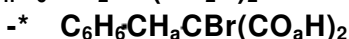

Derivatives of aminomalonic ester have been used to synthesise phenylalanine:

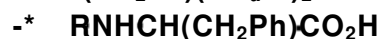
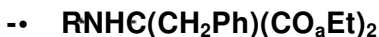
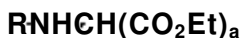

( $R=H$ , Cherchez and Locquin, *Bull. Soc. chim.* 1930, [iv], 47, 1274, 1386;  $R=PhCO$ , Dunn, Smart, Redemann, and Brown, *J. Biol. Chem.* 1931, 94, 599; Redemann and Dunn, *ibid.* 1939, 130, 341;  $R=MeCO$ , Albertson and Archer, *J. Amer. Chem. Soc.* 1945, 67, 308).

It is formed by reduction of the  $\alpha$ -oxime of phenylpyruvic acid, with zinc and hydrochloric acid (Erlenmeyer, *Ber.* 1897, 30, 2976), with aluminium amalgam (Knoop and Hoessli, *ibid.* 1906, 39, 1477) or catalytically (Shemin and Herbst, *J. Amer. Chem. Soc.* 1938, 60, 1901).



<Q-Phenylalanine forms short prisms from water, or shining plates (aq. ethanol), m.p. 263-265°\* (decomp.)  $pJ^{\wedge}_b=2.58$ ;  $p^{\wedge}=9.24$ ; isoelectric point,  $pI'=5.9$  (Miyamoto and Schmidt, J. Biol. Chem. 1931, 90, 165). Apparent acid dissociation constant in 9% aq. formaldehyde,  $pZ|_f=6.8$  (Dunn and Loshakoff, *ibid.* 1936, 113, 691). Ultra-violet absorption spectra may be used for identification, tyrosine and tryptophane being present in minimal amounts (Ross, *ibid.* 1934, 104? 531). It is less soluble than the Z-isomer (100 g. of water dissolves 1.411 g. at 25°, 2.187 g. at 50°; Dalton and Schmidt, *ibid.* 1933, 103, 549), indicating that it is a racemic compound, not a mixture.

**Derivatives.**—The hydrochloride, platinichloride, nitrate, sulphate, picrate (m.p. 173°), and picrolonate (m.p. 183°) are crystalline solids. Methyl ester, b.p. 141°/1 mm., *pf* 1-096, *ng* 1-5203, forms a hydrochloride, m.p. 158°. Ethyl ester, b.p. 143°/10 mm.,  $p^{15}$  1-065, sparingly water-soluble, forms a hydrochloride, nfp. 127°, and picrate, m.p. 156.5° (Curtius and Muller, Ber. 1904, 37, 1261). Diazomethane yields the methyl ester (50%) and the Jjetaine (39%) (Kuhn and Brydówna, *ibid.* 1937, 70 [B], 1333). Sodium amalgam reduction of the ethyl ester yields *d*?-*a*-amino-*p*-phenylpropionylacetal, b.p. 153.5°/11 mm. (Fischer and Kametaka, Annalen, 1909, 365, 7).

*N*-formyl derivative, soluble in 240 parts of water at 27°. *N*-benzoyl derivative, m.p. 187-188°, forms methyl ester, m.p. 87° (corr.) and ethyl ester, m.p. 95° (corr.) (Max, *ibid.* 1909, 369, 276). The amide, m.p. 138-139° (corr.) yields a *N*-*p*-naphthalenesulphonyl derivative, m.p. 141°. *N*-*p*-toluylacetyl derivative\* m.p. 126°; *N*-*p*-toluylsulphonyl derivative, m.p. 134-135°; phenylisocyanate derivative, m.p. 182° (decomp.); *N*-methyl derivative, m.p. 252-254°; phenyl-lactimide, 3:6-dibenzyl-2:5-diketopiperazine, m.p. 300° (corr.). Potassium cyanate yields *dl*-*a*-ureido-*p*-phenylpropionic acid, m.p. 188-191°. Acetic anhydride in pyridine yields benzylacetaminoacetone (Dakin and West, J. Biol. Chem. 1928, 78, 91).

**Metabolism of Phenylalanine.**

In normal individuals, phenylalanine is completely destroyed in the system, but in the abnormal, hereditary case of alcaptonuria, complete oxidation does not occur, and it is excreted as homogentisic acid (2:5-dihydroxyphenylacetic acid, *q.v.*). With the 2-isomer conversion is practically complete (Papagorge, Froehlich, and Lewis, Proc. Soc. Exp. Biol. Med. 1938, 38, 742; Lanyar, Z. physiol. Chem. 1942, 275, 217; 1943, 278, 155) but with the *c*Z-form only 40-45% is recovered; the conversion of the racemic form is also less complete (Falta and Langstein, *ibid.* 1903, 37, 513). The first step in the metabolism is probably the conversion to *p*-hydroxyphenylalanine (tyrosine), but a certain amount may be oxidised to phenylpyruvic acid. Phenylalanine is an essential amino-acid (*e.g.*, Womack and Rose, J. Biol. Chem. 1934, 107, 449) and cannot be replaced by tyrosine; deuterophenylalanine in normal rats is converted into tyrosine containing nuclear deuterium (Moss

and Schoenheimer, *ibid.* 1940, 185, 415). Phenylpyruvic acid may replace phenylalanine (Rose, Science, 1937, 86, 298).

R. B.

**PHLORETIN** occurs in the form of its glucoside *phloridzin*,  $C_{21}H_{24}O_{10} \cdot 2H_2O$ , m.p. 109°, in the bark and root bark of apple, pear, plum, and cherry trees. *Glycyphyllin*,



m.p. 175-180°\* which is present in the leaves of *Smilax glycyphytta* appears to be a rhamnoside of phloretin (Wright and Rennie, J.C.S. 1881, 39, 237; Rennie, *ibid.* 1886, 49, 857).

Phloretin,  $C_{16}H_{14}O_6$ , (I), needles, m.p. 262-264°, is soluble in alkalis with a yellow colour and on hydrolysis with aqueous potassium hydroxide yields phloroglucinol (II) and phloretic acid which Bougault (Compt. rend. 1900, 131, 42) showed to be identical with dihydro-*p*-coumaric acid (III). E. Fischer and Noun (Ber.

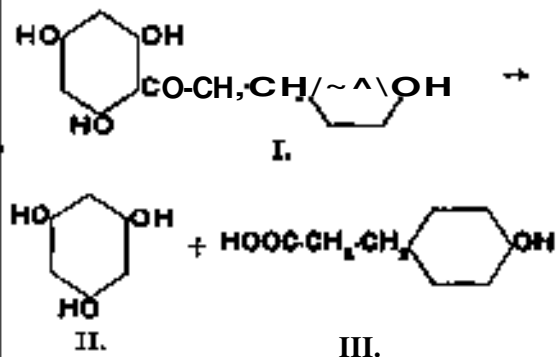

1917, 50, 611) synthesised phloretin by the hydrolysis of the ketone-imide prepared by condensing acetylphloretonitrile with phloroglucinol. Later syntheses are recorded by Zemple'n, Csirds, Gerecs, and Aczel (*ibid.* 1928, 61 [B], 2486) and Shinoda, Sato, and Kawagoe (J. Pharm. Soc. Japan, 1929, 49, No. 5ft, 123).

It is interesting that naringenin (5:7:4'-trihydroxyflavanone) which is present as the glucoside naringin in the blossoms of *Citrus aurantium* yields phloretin on catalytic reduction (Franck, Chem. Zentr. 1914, n, 253; Rosenmund and Rosenmund, Ber. 1928, 61 [B], 2608; see also Asahina and Inubuse, *ibid.* p. 1514).

Phloridzin%—On methylation with diazomethane, phloridzin yields\* a trimethyl derivative from which, by hydrolysis with acid, glucose and phloretin trimethyl ether (2-hydroxy-4:6-dimethoxyphenyl 0-*p*-methoxyphenylethyl ketone) are obtained (Wessely and Sturm, Monatsh. 1929, 53/54, 554; Johnson and Robertson, J.C.S. 1930, 21). Phloridzin, therefore, has the structure:

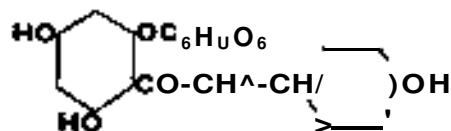

By methylating *phloridzin trimethyl ether*, m.p. 75-76°, with methyl iodide and silver oxide, Müller and Robertson (*ibid.* 1933, 1170) obtained a syrupy heptamethyl ether which on hydrolysis

yielded phlorizin trimethyl ether and 2:3:4:6-tetramethylglucose, indicating that phlorizin is a  $\beta$ -glucopyranoside. This was confirmed by the synthesis of trimethylphloretin  $\beta$ -D-glucoside. (See also Moelwyn-Hughes, J. Gen. Physiol. 1930, 13, 807; Bridel, Bull. Soc. Chim. biol. 1930, 12, 921; and Weidenhagen, Z. Ver. deut. Zucker-Ind. 1931, 81, 125.)

Zemle'n and Bognár (Ber. 1942, 75 [B], 1040) synthesised phloridzin by the action of aceto-bromoglucose on 4-benzoylphloracetophenone in aqueous acetone in presence of potassium hydroxide at room temperature; the resulting 2- $\alpha$ -glucosido-4-benzoylphloracetophenonetetraacetate was condensed with *jp*-hydroxybenzaldehyde under the influence of potassium hydroxide to naringenin 5-glucoside which on catalytic hydrogenation yielded phloridzin.

For the spectrographic study of phloretin and phloridzin, see Lambrechts (Compt. rend. 1933, 196, 295; 1934, 198, 1852).

Thermal decomposition of phloridzin heptaacetate gives  $\beta$ -D-glucose penta-acetate and 5-hydroxy-7-acetoxy-4-(4'-acetoxyphenyl)-ethyl coumarin (Jerzmanowska and Klosdwna, Roczn. Chem. 1938, 18, 234).

According to Bridel and Kramer (Compt. rend. 1931, 193, 748; Bull. Soc. Chim. biol. 1933, 15, 531) phloridzin is present in the leaves of *KtUmia latifolia*.

Asebotin,  $C_{22}H_{26}O_{10}$ , m.p. 148°,  $[\alpha]_D^{20}$  -46.2° in absolute alcohol, which is present in the leaves of *Andromeda japonica* Thunb., is phloridzin 4-methyl ether (Tamura, Bull. Chem. Soc. Japan, 1936, 11, 781; Z-mplén and Kester, Ber. 1942, 75 [B], 1298J).

E. J. C.

PHLORIDZIN (v. PHLOBETIN, this Vol., p. 481c).

PHCENICEIN («. PHCBNIN, *infra*).

PHCENIN,  $C_{14}H_{16}O_7$ , is found in the bark parenchyma cells of purple wood (*Copaifera bracteata*) and crystallises from water in minute colourless needles or rods which on exposure to air become slightly violet. By heating for an hour at 150-160°, or by the action of dilute acids, phoanin is converted quantitatively into the red colouring matter *ph&nicein* with elimination of 1 mol. of water.

Phoenicein,  $C_{14}H_{14}O_8$ , minute rods darkening at about 190°, is soluble in alkalis with a blue colour which becomes violet and finally brown. When treated with nitric acid it yields trinitroresorcinol and carbon dioxide, and the latter is also eliminated by dry distillation or by the action of alkali. Acetylphoenicein, obtained as a yellowish-white powder by the action of acetic anhydride, appears to contain three acetyl groups. The following is thus suggested as a possible formula for phoenicein:

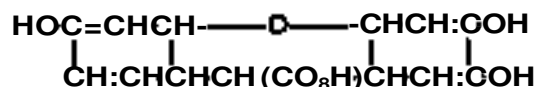

Purple wood yields approximately 2% of phoenicein (Kleerekoper, Chem. Zentr. 1901, n, 858, 1085).

E. J. C.

PHOLEDRIN E. *a-p*-Hydrjxyphenyl- $\beta$ -methylaminopropane. "Veritol" Circulatory stimulant. B.P.C. (Supp. III, App. XIV) (v. SYNTHETIC DRUGS).

S. E.

PHOSPHATE ROCK or PHOSPHORITE. The phosphate minerals of commercial importance contain calcium tribasic phosphate as their main constituent. They include apatite, a crystalline mineral of widespread occurrence in igneous and metamorphic rocks, and the amorphous or sub-microcrystalline hydrous calcium phosphates found in sedimentary rocks of various geological ages. The phosphatic content\* of rocks may be stated as percentage of calcium phosphate (sometimes called bone phosphate of lime, or briefly B.P.L.), or in terms of equivalent phosphorus pentoxide ( $P_2O_5$ ). Phosphate rock as mined varies greatly in composition, ranging from 25 to 90%  $Ca_3(PO_4)_2$ , or 10-40%  $P_2O_5$ . A typical commercial sedimentary rock phosphate from Florida, when cleaned, contains (approximately)  $Ca_3(PO_4)_2$  70,  $Fe_2O_3$  6,  $Al_2O_3$  6,  $SiO_2$  6, and F 2%.

Sedimentary rock phosphate, or phosphorite, occurs in two forms: in thick beds, usually of high phosphatic content; and in layers of nodules, commonly of lower phosphatic grade. The bedded phosphates are generally interstratified with calcareous formations, and may themselves contain much calcium carbonate. Richer varieties are often oolitic or concretionary, dark coloured rocks, sometimes with a whitish efflorescence; the poorer kinds may be described as phosphatic marls, limestones, or sands. Specimens vary from granular, loosely consolidated material to hard, dense varieties somewhat resembling chalcedony. They range in hardness from 2 to 5, but are usually harder than limestone, and slightly heavier. The colour of phosphorite varies from white, through grey and brown to almost black, the darker tones being commonly associated with a higher content of organic matter, which may reach 10%.

In addition to the extensive sedimentary phosphorites, such as those of Florida, Tennessee, Algeria-Tunisia, and Morocco, there are high-grade phosphate deposits in several islands of the Pacific and Indian Oceans. These consist of coral limestones that have been converted into phosphate rock by the infiltration of phosphatic solutions derived by the leaching of overlying beds of guano, the excrement of sea-birds.

Sedimentary phosphates consist mainly of amorphous or crypto-crystalline minerals, of which *coUoptonite*,  $Ca_3(PO_4)_2 \cdot H_2O$ , is a principal species. X-Ray diffraction patterns also indicate the common presence in phosphorites of *fluorapatite*, *hydroxyapatite*, *staffelite*, and *dahlite*; in the last two minerals the fluorine of fluorapatite,  $Ca_5F(PO_4)_3$ , is partly or wholly replaced by the carbonate radical, whilst in hydroxyapatite all or most of the fluorine is replaced by OH. Recent American investigators assert that the phosphate of all commercial varieties of phosphate rock mined throughout the world is an apatite-like mineral and mostly is fluorapatite or hydroxyapatite.

The term phosphate rock, as used in the trade, includes deposits of igneous origin which are rich

in the mineml apatite,  $\text{Ca}_6\text{F}(\text{PO}_4)_3$  with traces of chlorine. Immense bodies of crystalline granular apatite are now being exploited in the Kola Peninsula, near Kirovsk, U.S.S.R., where the phosphate rock occurs as a great lens within alkaline igneous rocks.

A ready field test for phosphorus can be made by adding a few drops of a nitric acid solution of ammonium molybdate to a freshly broken surface of the rock, which quickly becomes coated with a film of yellow ammonium phosphomolybdate if any phosphate is present.

The average world production of phosphate rock (including apatite) during 1934-38 was 11,200,000 tons. This was obtained as follows: U.S.A. 31% (mainly from the "land pebble" deposits of Florida, and the residual "brown" rocks, of Tennessee); U.S.S.R. 18% (chiefly from the K&L apatite deposits); Tunisia 15%; French Morocco 12%; Ocean and Nauru Islands 8%; Algeria 5%; Egypt 4%; Japanese Islands 2%; Christmas Island 1.4%; others 3.6%.

About 90% of the total production of phosphate rock is utilised for making fertiliser. Ordinary superphosphate, made by treating the raw phosphate with sulphuric acid, contains about 18% of  $\text{P}_2\text{O}_5$  in soluble form, but double and triple superphosphates made by treating the raw material with phosphoric acid have a range of 40-60% of water-soluble  $\text{P}_2\text{O}_5$ . For the cultivation of certain crops the place of superphosphate may to some extent be taken in the future by the "Rhenania," or high-temperature phosphates formed by fusing or sintering mineral phosphate with sand and soda at a temperature high enough to eliminate fluorine. The resulting soda-lime silico-phosphate has a high citric-acid solubility, the total available  $\text{P}_2\text{O}_5$  amounting to about 25% of the material.

Small amounts of phosphate rock are used for the production of elemental phosphorus, phosphoric acid, trisodium phosphate, and other phosphorus chemicals, and in the manufacture of safety matches, baking powder, stock food, etc. A considerable tonnage of the raw material is also required in blast-furnaces for the making of ferrophosphorus, and phosphor-bronze is a widely-used alloy. Some colloidal phosphate and finely pulverised phosphate rock is employed for direct application to the soil as a fertiliser.

*Reference.*—"Industrial Minerals and Rocks"/American Institute of Mining and Metallurgical Engineers, New York, 1937, Chap. XXXIII, by H. S. Martin and J. Wilding (brief review and bibliography).

D. W.

## PHOSPHORUS.

### SYNOPSIS.

- I. *Elemental Phosphorus* (p. 483c). Isotopes. Allotropic forms. Chemical properties. Phosphorus vapour, molecular constants, and thermodynamic functions. White phosphorus, physical properties. Radioactive phosphorus.
- II. *Manufacture of White Phosphorus* (p. 486\*). Early manufacture. Blast furnace. Electrothermal process. Treatment of phosphorus. By-products.
- III. *Manufacture of Phosphoric Acid* (p. 491c). Conversion of phosphorus to phosphoric acid. Treatment of the phosphoric acid. Wet-process phosphoric acid. Purification. Uses.
- IV. *Red Phosphorus* (p. 49W). Physical properties. Manufacture.

- V. *Phosphorus as an Industrial Hazard* (p. 4996). Poisonous properties. Spontaneous combustion. Burns.
- VI. *Oxides and Sulphoxides of Phosphorus* (p. 4994).
- VII. *Oxyacids of Phosphorus. Peracids of Phosphorus* (p. 5024).
- VIII. *Pyrophosphates, Metaphosphates, and Polyphosphates of Sodium* (p. 508c).
- IX. *Phosphides* (p. 514c). Hydrogen phosphides. Metallic phosphides.
- X. *Halides of Phosphorus* (p. 517a).
- XI. *Oxyhalides and Thiohalides of Phosphorus* (p. 519a).
- XII. *Phosphorus Cyanides and Related Compounds* (p. 522a).
- XIII. *Sulphides of Phosphorus* (p. 522c).

### I. ELEMENTAL PHOSPHORUS.

Sym. P. At. wt. 30.98. *Isotopes*: One stable,  $^{31}\text{P}$ , with nuclear spin  $\frac{1}{2}$  Bohr unit; two unstable,  $^{30}\text{P}$ , half-life 3.2 min., emits positrons;  $^{32}\text{P}$ , half-life 14.3 days, emits electrons.

*Allotropic Forms.*—Ordinary white phosphorus crystallises in the cubic system. At  $-77^\circ$  under atmospheric pressure there is reversible transformation to a second, slightly denser, form of white phosphorus (hexagonal modification). Crystalline black phosphorus, orthorhombic, density 2.69-2.70, is formed by heating to  $200^\circ\text{C}$ . under 12,000 atm. It resembles graphite in appearance, and has a specific conductance of  $1.4\ \text{ohm}^{-1}$  at room temperature, increasing at higher temperatures. The thermal conductance also increases with temperature. The discovery of these two allotropes is due to P. W. Bridgman's investigations at very high pressures (J. Amer. Chem. Soc. 1914, 36, 1344). Crystalline black phosphorus is the densest, and chemically the least reactive of the allotropes. A black phosphorus has also been obtained from white at room temperature, by application for a short time of 100,000 atm. pressure. This reverted to white phosphorus on keeping at ordinary pressure (P. L. Günther, J. Gesell, and W. Reberisch, Z. anorg. Chem. 1943, 250, 373). The stability of black modifications of phosphorus relative to other forms awaits clarification. An amorphous variety of black phosphorus, density 2.25, is also obtained by heating white phosphorus under pressure (E. B. Jacobs, J. Chem. Physics, 1937, 5, 945).

White phosphorus, protected from air and light, remains unchanged indefinitely at ordinary temperatures. When heated under normal or not very high pressures to about  $200^\circ\text{C}$ . (or even  $100^\circ\text{C}$ . in the presence of an active catalyst such as phosphorus di-iodide) it changes slowly into a bright red form. The white phosphorus may be molten or in solution; in phosphorus tri-bromide, for example, which is both a solvent and a catalyst, red phosphorus slowly forms at the boiling-point of the solvent. A similar red form is produced by the action of light or X-rays. The colour, density, and reactivity of red phosphorus, even when produced without the intervention of solvents or catalysts, are to some degree a function of the conditions (temperature and time) of the transformation (v. Bed Phosphorus, Manufacture, p. 497Z). Some authors refer to violet phosphorus, and this is a closer description of the colour of the chemically fairly stable material made commercially.

Bed phosphorus is chemically less reactive than white, except under circumstances where the small specific surface of molten white phosphorus is the obvious explanation of the contrary observation. It is denser, has a much lower vapour pressure, and is almost insoluble even in solvents which freely dissolve white phosphorus; in these respects red phosphorus resembles black. The marked differences between white phosphorus and the coloured allotropes are associated with a major difference of molecular structure. White phosphorus is composed of  $P_4$  molecules, tetrahedral in shape, each atom being symmetrically linked to three others. The atomic distance is 2.21 Å. (L. R. Maxwell, S. B. Hendricks, and V. M. Mosley, *ibid.*, 1935, 3, 699). The only forces acting between these non-polar molecules are of the van der Waals type, and in solution, in the molten state, and in the saturated vapour at least up to 700°. an adequate description of the molecular state of white phosphorus is that it consists of stable and unassociated  $P_4$  molecules. Black and red phosphorus, on the other hand, are high polymers. In crystalline black phosphorus the atoms are co-valently linked in extended networks or layers, and crystalline red phosphorus has a similar structure. The atomic spacings have been studied by X-ray diffraction (B. Hultgren, N. S. Gingrich, and B. E. Warren, *ibid.* 1935, 3, 351; C. D. Thomas and N. S. Gingrich, *ibid.* 1938, 6, 659).

**Chemical Properties of Elemental Phosphorus.**—Phosphorus, especially white phosphorus, is a very reactive element. It combines directly and often, vigorously with most other elements; exceptions are carbon, boron, silicon, and the rare gases, possibly also titanium, zirconium, lead, bismuth, and mercury. With the halogens and with oxygen reaction is spontaneous and highly exothermic. With sulphur, and with the alkali metals, vigorous reaction starts below 250°. Metals in general form phosphides (*q.v.*) by heating in phosphorus vapour or with red phosphorus. In many instances, including iron, nickel, copper, and platinum, the mass may become incandescent. Gaseous atomic hydrogen and nascent hydrogen form phosphine; molecular hydrogen reacts with phosphorus under pressure at 360°. Binary compounds of phosphorus with all other elements except the rare gases are known or must be presumed by analogy.

Characteristic of the chemical behaviour of elemental phosphorus is its strong reducing action. Water at high temperatures and pressures is decomposed by white or red phosphorus, with formation of oxyacids of phosphorus and phosphine and hydrogen. Alkaline solutions attack white phosphorus slowly even in the cold (*v. Hypophosphites*, p. 501*d*). White phosphorus precipitates metals such as copper, silver, and others electrochemically less positive, from solutions of their salts. Physiologically, white phosphorus is a strong poison; red phosphorus is inert.

The oxidation of white phosphorus is accompanied by remarkable phenomena which have been the subject of many investigations but are still interpreted only with the aid of speculation.

White phosphorus, in moist air at room temperature, glows brightly with a greenish light. The glow intensity is parallel to the rate of oxidation of phosphorus, and it is attributed to reactions in which phosphorus vapour is concerned. The radiation extends into the ultraviolet region. The glow is destroyed or diminished by many organic vapours (ethylene, turpentine, iodobenzene) and many other substances, notably phosphine. There is a definite upper limit to the partial pressure of oxygen in which phosphorus will glow, the limit being a function of temperature and of water vapour content. For example, at 15°. the limit for oxygen saturated with water vapour is 600 mm. Only a trace of oxygen is required to produce the glow in carbon dioxide or hydrogen chloride.

Besides the upper pressure-limit for the glow there is a lower limit to the oxygen pressure or partial pressure at which phosphorus vapour will oxidise. The lower limit is a function of temperature, partial pressure of phosphorus vapour, presence of inert gases, shape and size of reaction vessel. The discovery and investigation of this pressure limit by J. Chariton and Z. Walta (*Z. Physik*, 1926, 39, 547) and N. Semenov (*ibid.* 1927, 46, 109) played an important part in the development of the kinetic theory of chain reactions in gases.

Associated with the low temperature oxidation of phosphorus under glow conditions are also the production of ions in the gas phase, and of ozone. The older literature on the glow of phosphorus and associated phenomena is reviewed by J. W. Mellor, "A Comprehensive Treatise on Inorganic and Theoretical Chemistry," Vol. VIII, Longmans, 1928. A recent study of the relation between the glow of phosphorus and its ignition has been reported by F. S. Dainton and J. C. Bevington (*Trans. Faraday Soc.* 1946, 42, 377).

The products of oxidation of phosphorus at comparatively low temperatures in an excess of dry oxygen are phosphorus tetroxide and pentoxide (C. C. Miller, *J.C.S.* 1929, 1829), whereas burning in a deficiency of oxygen gives a mixture of trioxide and pentoxide.

**Phosphorus Vapour.**—The vapour of white phosphorus in the neighbourhood of its boiling-point consists of  $P_4$  molecules, as Dumas showed in 1823. At considerably higher temperatures dissociation to  $P_2$  molecules occurs. A careful study of the equilibrium  $P_4 \rightleftharpoons 2P_2$  was made by A. Stock, G. E. Gibson, and E. Stamm (*Ber.* 1913, 45, 3527). Up to 700°C. no measurable dissociation occurs. Between 900° and 1,200°. the dissociation constant (expressed in atm.) increased from  $6.45 \times 10^{-3}$  to  $6.118 \times 10^{-1}$ . A statistical mechanical evaluation of  $\Delta H$  from the four equilibrium constants in this temperature range determined by A. Stock, G. E. Gibson, and E. Stamm, has been made by D. P. Stevenson and D. M. Yost (*J. Chem. Physics*, 1941, 9, 403), who found  $\Delta H$  satisfactorily constant at 53,615 g.-cal. per g.-mol. of  $P_4$ . Similarly, using a spectroscopic estimate of  $J/J = 115,450$  g.-cal. per g.-mol. of  $P_2$  for the further dissociation into atoms, the dissociation constant at 1,100°C. is  $3.6 \times 10^{-1}$ , in agreement with A. Stock, G. E. Gibson, and E. Stamm's conclusion that it is

immeasurably small, and contrary to the experimental work of G. Preuner and I. Brockmüller (Z. physikal. Chem. 1913, 81, 129). A statistical computation of the equilibrium  $P_4 \rightleftharpoons 2 P_2$  has been given by H. Zeise (Z. Elektrochem. 1934, 40, 885).

**Molecular Constants and Thermodynamic Functions of Gaseous  $P_4$ ,  $P_2$ , and P.**—Calculated values, of the *heat content*, *heat capacity*,  $C_p$ , and *Gibbs free-energy* are tabulated below. The *entropy* for the standard state (298.1° and 1 atm.) is also given. The evaluations are based on the following data and assumptions. The substances are treated as perfect gases. The P atom is in a  $^4S$  state and the  $P_2$  molecule is a  $^3\Sigma$  state. The electronic statistical weight of the  $P_4$  molecule is unity. The nuclear spin contribution to the partition functions is excluded. The moment of inertia of  $P_2$  is  $92.36 \times 10^{-40}$  g.-cm.<sup>2</sup> (G. Herzberg, Canad. J. Res. 1940, 18, 139). The moments of inertia of the tetrahedral  $P_4$  molecule are  $251 \times 10^{-40}$  g.-cm.<sup>2</sup>, corresponding to the interatomic distance quoted above. The frequency  $\nu_e$  of the vibrational energy terms of  $P_8$  is  $780.34 \text{ cm.}^{-1}$ , and the first anharmonicity constant  $x_{e0}$  is  $2.804 \text{ cm.}^{-1}$  (G. Herzberg, "Molecular Spectra and Molecular Structure," Vol. I, Prentice-Hall Inc., New York, 1939); since only the first two or three levels contribute appreciably to the partition function of  $P_4$  even at  $1,500^\circ \text{K.}$ , a constant frequency ( $\nu_e - 2x_{e0} < a_e$ ) =  $774.8 \text{ cm.}^{-1}$  has been used in the vibrational partition function. The frequencies and degeneracies for  $P_4$  are 363 (2); 465 (3); 606 (1) (see G. Herzberg, "Infra Red and Raman Spectra of polyatomic Molecules," D. van Nostrand Co. Inc., New York, 1945). These frequencies have been used in the harmonic oscillator partition function. Interaction of rotation and vibration has been neglected for both molecules. The heat content  $H^\circ$ , and the negative of the Gibbs free energy divided by the absolute temperature,  $-G^\circ/T$ , are relative to the lowest energy state of the specified system (atom or molecule). The entropy  $S_{298.1}^{\text{int}}$  and the Gibbs free energy are for 1 atm. pressure.

Temp., °K.	#0, kg.-cal. per g.-mol.		Cp, g.-cal. per g.-mol. per °C.	
	P2.	P4.	P2.	P4.
223	1.57	2.24	7.30	14.12
248	1.75	2.60	7.42	14.88
273.1	1.94	2.98	7.53	15.12
298.1	2.13	3.38	7.65	16.05
350	2.53	4.24	7.86	16.91
400	2.93	5.10	8.04	17.51
500	3.75	6.89	8.29	18.08
600	4.58	8.74	8.46	18.73
700	5.43	10.63	8.57	19.01
800	6.30	12.54	8.65	19.20
900	7.16	14.47	8.70	19.34
1,000	8.04	16.41	8.74	19.44
1,100	8.91	18.38	8.78	19.51
1,200	9.79	20.31	8.80	19.56
1,300	10.67	22.27	8.82	19.61
1,400	11.55	24.23	8.83	19.64
1,500	12.44	26.19	8.85	19.67

Temp., °K.	-G*/T, g.-cal. per g.-mol. per °.		
	P.	P2.	P4.
223	32.59	42.89	52.51
248	33.12	43.67	53.55
273.1	33.60	44.03	54.64
298.1	34.03	44.95	55.61
350	34.83	46.10	57.49
400	39.49	47.07	59.14
500	36.60	48.73	62.11
600	37.51	50.13	64.68
700	38.28	51.30	66.98
800	38.94	52.34	69.05
900	39.52	53.26	70.91
1,000	40.04	54.11	72.64
1,100	40.52	54.88	74.30
1,200	40.95	55.59	75.67
1,300	41.35	56.24	77.04
1,400	41.72	56.85	78.31
1,500	42.06	57.42	79.51

-S <sub>298</sub> g.-cal. per g.-mol. per °.		
P.	P2.	P4.
38.99	52.10	66.95

**Heat Capacities.**—Empirical equations have been derived by H. M. Spencer and G. N. Flanagan (J. Amer. Chem. Soc. 1942, 64, 2511) from a tabulation of heat-content values calculated by D. P. Stevenson and D. M. Yost (J. Chem. Physics, 1941, 9, 403). The latter are similar to the values given above, but some discrepancies in the free-energy values given by these authors made a complete recalculation necessary. For gaseous  $P_2$ ,  $C_p = 8.643 + (0.202 \times 10^{-3})T - (1.030 \times 10^{-6})/T^2$ , and for gaseous  $P_4$ ,  $C_p = 19.227 + (0.509 \times 10^{-3})T - (2.075 \times 10^{-6})/T^2$ , where in both formulae  $298 < T < 1,600$ .

**White Phosphorus, Cubic Modification and Liquid, Physical Properties.**—M.p.  $44.25 \pm 0.05^\circ \text{C.}$  at 1 atm. (Numerous less accurate figures appear in the literature, doubtless chiefly because of the presence of traces of arsenic and sulphur which are not readily removed by vacuum or steam distillation. The high molecular lowering of the freezing-point ( $39^\circ$ ) necessitates a purity exceeding 99.99% if the melting-point is to be reliable to within  $0.1^\circ \text{C.}$  Also, because of the large pressure-dependence of the melting-point ( $0.033^\circ \text{C.}$  for 1 atm) it is desirable to adopt a procedure for determining the melting-point which avoids stresses that may be present in the glass-like mass obtained when slightly supercooled phosphorus solidifies.) Under water, the melting-point at atmospheric pressure of otherwise pure phosphorus is still within the temperature range  $44.25 \pm 0.05^\circ \text{C.}$  Molten white phosphorus supercools readily, and may remain liquid as much as  $50^\circ \text{C.}$  below the melting-point. If the supercooling amounts to more than a few degrees, crystallisation spreads from a nucleus at a very high linear rate. *Latent heat of fusion*  $601 \pm 2$  g.-cal. per g.-mol. of  $P_4$  at the melting-point (F. E. Young and J. H. Hildebrand, J. Amer. Chem. Soc. 1942; 64, 839). *Density. Solid*  $\rho_4^{\text{TM}} = 1.8233$ ;  $\rho_4^{\text{L}} = 1.8079$ . The expansion on melting at atmospheric pressure

is 3-26%. *Liquid p* =  $l-76705-00009222(*-20)$  where  $20^\circ < t^\circ \text{C.} < 280^\circ$  (St. Dobinski, Z. Physik, 1933, 83, 129). *Viscosity*. An interpolation formula consistent with the data of St. Dobinski (Bull. Acad. Polonaise, 1934, A, 103) and A. N. Campbell and S. Katz (J. Amer. Chem. Soc. 1935, 57, 2051) is  $\log_{10} \eta$  (poises) =  $-2.6318 - 10.67/T + (9.00 \times 10^4)/T^2$ , where  $290^\circ < T^\circ \text{K.} < 415^\circ$ . *Surface tension*,  $\gamma$  (dynes per cm.) =  $69.70$  at  $50.0^\circ \text{C.}$ ;  $68.53$  at  $540.0^\circ$ ;  $66.95$  at  $60.2^\circ$ ;  $64.95$  at  $68.7^\circ \text{C.}$  (all  $\pm 0.3$  unit) (E. Hutchinson, Trans. Faraday Soc. 1943, 39, 229). The *parachor* of  $P_4$  is 205. *Heat capacity, solid, white (cubic)*,  $C_p = 21.46 + (2.872 \times 10^{-5})t$  per g.-mol. of  $P_4$ , where  $0^\circ < t^\circ \text{C.} < 44.2^\circ$ . *Liquid*,  $C_p = 24.47 - (9.521 \times 10^{-3})t - (3.927 \times 10^{-5})t^2$  per g.-mol. of  $P_4$ , where  $25^\circ < t^\circ \text{C.} < 97^\circ$ . Both formulae are given by F. E. Young and J. H. Hildebrand (J. Amer. Chem. Soc. 1942, 64, 839). *Vapour pressure, liquid*. The only accurate data are those of D. Macrae and C. C. van Voorhis (*ibid.* 1921, 43, 547) summarised by  $\log_{10} p(\text{mm.}) = 7.9542 - 2.7575/T$ , where  $317^\circ < T^\circ \text{K.} < 423^\circ$ . The accuracy claimed is  $\pm 0.5\%$  from  $150^\circ$  to  $100^\circ \text{C.}$ , and  $\pm 5\%$  at  $44^\circ \text{C.}$  Calculated from this vapour pressure formula, the *latent heat of vaporisation of liquid phosphorus* is 12,612 g.-cal. per g.-mol.  $P_4$ . Liquid white and liquid red phosphorus (*q.v.*) are believed to be the same, and the formula  $\log_{10} p(\text{mm.}) = 11.5694 - 2.898/T - 1.2566 \log_{10} T$  is given by D. Macrae and C. C. van Voorhis (*ibid.*) as representing all the reasonably reliable data by different investigators of white and red phosphorus, in the range  $317^\circ < T^\circ \text{K.} < 907^\circ$ . *Vapour pressure, solid white (cubic)*. The published measurements are not very satisfactory. Calculation from measurements on the liquid, together with available data for the heat capacities of liquid, vapour, and solid, and the heat of fusion, is more accurate. Taking the latent heat of vaporisation derived from the two-constant formula of D. Macrae and C. C. van Voorhis (*v. supra*) as applying best to the middle of their temperature range, and utilising thermal data already quoted, the *latent heat of vaporisation of solid white phosphorus (cubic)* is calculated to be 13,570 g.-cal. per g.-mol. of  $P_4$ , at the melting-point. Introducing additionally the heat capacity of solid white phosphorus (cubic) the Clausius-Clapeyron equation can be integrated from the melting-point to that at which the vapour pressure is equal to 0.181 mm., from the vapour pressure data for the liquid) over the range of validity of the expression for the heat capacity of the solid. The resulting expression containing five terms does not differ numerically by as much as 1% from the simpler formula  $\log_{10} p(\text{mm.}) = 8.7011 - 2.9962/T$ , where  $273^\circ < T^\circ \text{K.} < 317.3^\circ$ . Some of the measurements of M. Centnerszwer from  $20^\circ$  to  $40^\circ \text{C.}$  (Z. physikal. Chem. 1913, 85, 99) are consistent with this, but those of K. Fischbeck and H. Eich (Z. anorg. Chem. 1937, 235, 83), particularly in the lower half of their temperature range  $0$ - $20^\circ \text{C.}$ , are considerably smaller.

*Solubility of White Phosphorus*.—Phosphorus is almost-insoluble in water. It is extremely soluble in carbon disulphide (31-40 at  $-10^\circ \text{C.}$ , 81-27 at  $0^\circ \text{C.}$ , 89-8 wt.-% of P at  $10^\circ \text{C.}$ ). It is soluble in many, probably in most, organic

liquids to a small extent. The following are in g. per 100 g. of solvent: benzene at  $20^\circ \text{C.}$ , 3-2; at the boiling-point, 10-03; paraffin at  $15^\circ \text{C.}$ , 1-5; diethyl ether at  $20^\circ \text{C.}$ , 0-9; ethyl alcohol at  $20^\circ \text{C.}$ , 0-3; glycerol at  $15^\circ \text{C.}$ , 0-25.

*Applications of Radioactive Phosphorus*.—The isotope JJP, with a half-life of 14.3 days, has been used as a tracer in analytical work (A. Langer, J. Physical Chem. 1941, 45, 639) and for studying the facility of interchange of phosphorus atoms between molecules, for example in ortho-, pyro-, and meta-phosphates (D. E. Hull, J. Amer. Chem. Soc. 1941, 63, 1269). An interesting example of its use to investigate the mechanism of a chemical reaction is E. Chargaff's work on the  $\alpha\beta$  isomerism of glycerophosphates (J. Biol. Chem. 1942, 144, 455). Numerous applications of  $^{32}\text{P}$  as a tracer in biological work (G. von Hevegy, Enzymologia, 1938, 5, 139, and J.C.S. 1939, 1213) include rate determinations for phosphorus metabolism, uptake by bone tissue, and the formation in the body of particular organic phosphorus compounds. It appears that phosphorus is selectively concentrated in certain parts of the body where growth and new cell formation are most active. A new method of treating some diseases is thus available, by selective radiation of the absorbing tissue (W. E. Chamberlain, Chem. Eng. News, 1946, 24, 1352).

## II. MANUFACTURE OF WHITE PHOSPHORUS.

Although white phosphorus had been sold as a curiosity from the time of its discovery, manufacture as a serious commercial venture did not start before about the end of the first quarter of the nineteenth century. The first production was in France and Germany. In England Arthur Albright established manufacture in 1844, at Birmingham. Until the end of that century the chief uses were in the making of matches and pharmaceutical chemicals.

From the early years of the present century, and to a continuously increasing extent, elemental phosphorus has been burnt to phosphorus pentoxide. Either simultaneously or in a subsequent step the pentoxide is hydrated to concentrated phosphoric acid, from which is made a large fraction of the industrially useful phosphates and some phosphate fertiliser; the scale of present-day manufacture of phosphorus is controlled by these outlets.

*Early Manufacture*.—The earliest manufacturing process for obtaining phosphorus from calcium phosphate (bone ash originally, later phosphate ore), which was employed for very many years but is now only interesting historically, took advantage of the comparative ease of reduction of phosphoric acid by making first the acid from sulphuric acid and calcium phosphate. The phosphoric acid, concentrated by evaporation, was mixed with sawdust, charcoal or coke, and the mixture dried and charred. The product was charged into bottle-shaped fire-clay retorts set in a coal-fired brick furnace. At a temperature approaching white heat phosphorus distilled out and was condensed under water:

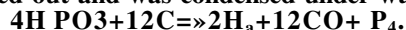

distinct from phosphate fertiliser manufacture). Moreover, in most countries where only the fertiliser scale of manufacture could justify so large a phosphorus unit as an efficient blast furnace, the situation has been dominated by the alternative process for making phosphate fertilisers, namely reaction of phosphate ore with sulphuric acid (superphosphate or triple superphosphate). However, it is reasonable to expect that progressive technical integration of heavy chemical manufacture may alter the balance of cost factors and therefore the choice of method; one possibility which has been considered is the improvement of the performance of the blast furnace by supplying it with oxygen enriched air, whilst collaterally utilising the nitrogen enriched air.

**Electrothermal Process.**—The earliest patent protecting the use of electrical energy for producing phosphorus was granted in England, to J. B. Readman, in 1888; T. Parker and A. E. Robinson applied for letters patent a little later in the same year. Readman tried out his ideas

in conjunction with the Cowles Coy. Ltd., near Stoke-on-Trent, and Parker and Robinson (the Electric Construction Co., Ltd.) experimented independently, near Wolverhampton. About 1891 a new phosphorus factory was constructed near Wolverhampton as a joint venture, to prove the commercial feasibility of the Readman-Parker-Robinson furnace. A number of small furnaces each of 60 kw. were used, and a volatilisation of over 75% of the phosphorus, with an electrical energy consumption under 10 kw.-hr. per lb. of phosphorus was achieved.

Although the evolution of design of electrothermal phosphorus furnaces through half a century of experience has resulted in considerable variations of detail in different works and different countries, there are probably no important differences of principle. It is usual to have several furnaces in a factory, so that the electrical load is not subject to a large percentage change when a furnace is shut down for repairs. The smallest commercial units consume about 1,500 kw., the largest at present (1946) in use

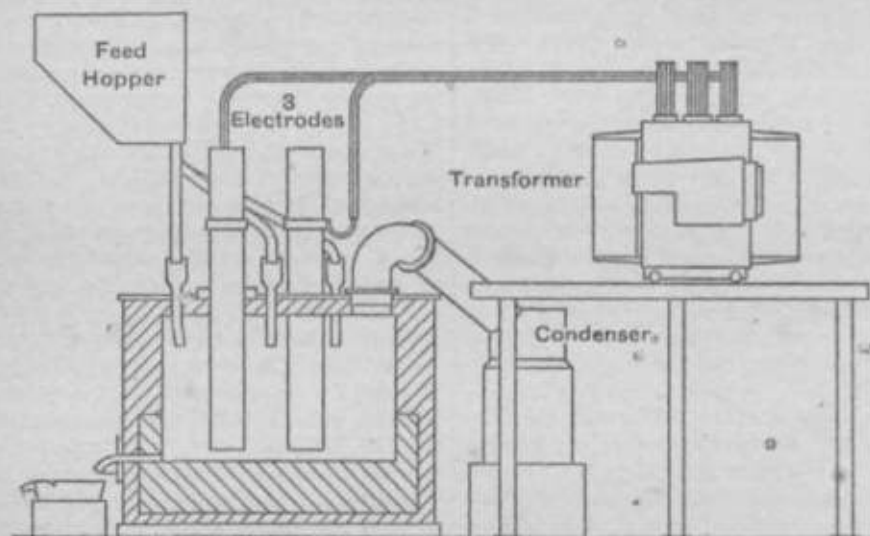

FIG. 1.

probably about 15,000 kw. According to the quality of raw materials available and the size of the furnace, the consumption of electrical energy varies in the range 5-8-7-0 kw.-hr. per lb. of phosphorus produced, including phosphorus in the by-product ferrophosphorus.

Phosphorus furnaces are three-phase, and operate at commercially available frequencies with a voltage of 170-260 between electrodes. During the past twenty years the tendency has been towards increased voltages, and manufacturers are contemplating trials with still higher voltages. The electrodes are cylindrical and hang vertically in the furnace. Fig. 1 shows a section through a furnace; in plan it is circular with the three electrodes symmetrically placed. (Phosphorus furnaces are sometimes built rectangular in plan, the advantage being simplicity of furnace superstructure, especially the Dus-bar layout, and ease of access to the electrodes for renewal.) The electrodes are either of the Soderberg type, or hard carbon, usually the latter. Electrode current\* run from

6,000 to 30,000 amp., the large values requiring water-cooled electrode clamps for connection to the bus-bars, and carbon electrodes of up to 40 in. diameter. As in all electric furnaces, care must be taken in the design of the secondary bus-bars to obtain minimum reactance. The furnace power factor usually lies between 0.90 and 0.98. To minimise eddy-current losses and reactance, sections of the furnace cover are made of non-magnetic material. The furnaces are best operated as constant current units and automatic control of the position of the electrodes (*i.e.*, distance of the electrode end above the molten slag pool) is customary; for this purpose electromagnetic relays are used to operate the winches attached to the electrodes. The relays themselves are actuated by current transformers placed in either the primary or the secondary circuits of the main furnace transformer. Primitive stuffing boxes are fitted where the electrodes pass through the furnace cover; on large furnaces they are water-cooled. The gas pressure in the furnace is only a fraction of an



The article entitled PHOSPHORUS in Vol. IV of the 1913<sup>rd</sup> edition of this Dictionary contains an authoritative and detailed description by J. B. Headman of this early process.

The economic disadvantages of the earlier process had been conspicuous for many years before it was superseded. Changes obviously desirable were elimination of use of sulphuric acid, and a furnace that would work continuously. Both are achieved by heating a mixture of calcium phosphate, silica, and carbon to white heat, as first proposed by F. Wöhler (Pogg. Annalen, 1829, 17, 179).

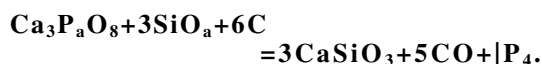

The calcium oxide is eliminated from the system as molten calcium silicate and uninterrupted operation of the furnace becomes feasible. (In the absence of all acidic flux such as silica or alumina, higher temperatures are necessary, and, depending upon the conditions, calcium phosphide or carbide is formed, but cannot readily be slagged out of the furnace.) The necessary heat is supplied either by burning excess fuel, as in the blast-furnace method, or electrically. The industrial use of silica as a flux was foreshadowed in 1867 by V. Aubertin and Boblique (F.P. 77454) and the idea of reducing phosphate by means of a blast furnace was the subject of B.P. 3515, 1868 (to Brison), 1593, 1870 (to Aubertin), and 49, 1879 (to Serve). The earliest serious practical attempt (although only on a pilot-plant scale) to use the principle of the blast furnace seems to have been about 1887 by J. B. Readman, in the neighbourhood of Edinburgh; the effort was unsuccessful because the temperature could not be kept high enough to get the slag sufficiently fluid.

**The Phosphorus Blast Furnace.**—The experimental difficulties of full-scale phosphorus manufacture by the blast-furnace principle were overcome in the U.S.A., and one or two phosphorus blast furnaces have been worked in that country. An illustrated description of pilot plant work and full-scale design and operation of a blast furnace built at Nashville, Tennessee, by the Victor Chemical Co. has been given by H. W. Easterwood (Trans. Amer. Inst. Chem. Eng. 1933, 29, 1). This furnace had a capacity of 15,000 tons of phosphorus per year in the form of "furnace gas" consisting principally of phosphorus vapour, carbon monoxide, and nitrogen. The furnace gas carried some silica and carbonaceous dust which was removed by passage through a series of dust collectors. The treatment of the clean furnace gas was to cool a proportion of it by water sprays, separating molten phosphorus under hot water, and to burn the remainder. The gas to be burnt was divided into two streams, part being burnt in heat exchange stoves which served to preheat the air-blast for the furnace to 600-700°C, the remainder being burnt in steam-raising boilers. The gaseous combustion products carrying phosphorus pentoxide vapour were hydrated and cooled by internal evaporation of water; a mist was produced from which phosphoric acid was collected partly in the hydrator itself, partly in the connecting mains, and finally by electro-

static precipitation. The acid obtained in this plant, although more concentrated (up to 90%  $\text{H}_3\text{PO}_4$ ) than phosphoric acid made by the "wet process" (*v. infra*) was much less pure than acid made by separating the phosphorus first and burning it in a separate stage. Typical analytical data are:  $\text{P}_2\text{O}_5$  54-88, (Fe and Al)  $\text{PO}_4$  0-13,  $\text{SO}_3$  0-01, total bases 0-60%.

The blast furnace was charged with skip-loads of dried briquettes of ground phosphate rock mixed with about half the carbon stoichiometrically required for reduction of the phosphate; mixed with the briquettes were silica (gravel) and coke. The overall weight ratio of silica to lime in the materials fed to the furnace was adjusted so that the slag had a lime to silica weight ratio of 1.2 to 1, because experience showed that trouble from volatilised silica was reduced thereby. Slag was tapped hourly. Almost the whole of the iron content of the ore, gravel, and coke was reduced to ferrophosphorus (containing 20-25% of P) and this was tapped twice daily. The silicate slag contains about 1% by weight of phosphorus, partly in the form of calcium silicophosphate, partly as suspended particles of ferrophosphorus. Fluorine is contained in the furnace charge because the phosphate ore is normally closer in composition to fluorapatite,  $\text{CaF}_2 \cdot 3\text{Ca}_3\text{P}_2\text{O}_8$ , than to tricalcium phosphate. The greater part of the fluorine was found in the slag, but some was volatilised as  $\text{SiF}_4$ . The deliberate use of hydrofluosilicic acid dissolved out of the moist furnace gases after spray cooling, to promote breakdown of the emulsion of condensed phosphorus droplets, is described in G.P. 634949, 1932 (ft Metallgesellschaft); it arose from trouble encountered during the brief operation of a blast furnace in Pembroke, Florida.

The yield of volatilised phosphorus was as high as 95%, and the yield as phosphoric acid was up to 90% of the total phosphorus content of the furnace charge. No phosphorus blast furnace has been operated on a commercial scale in the United Kingdom, and published information is virtually restricted to the article by Easterwood.

At the present time in all countries most, if not all, of the phosphorus, and phosphoric acid or phosphates so far as these are derived from phosphorus, are produced electrothermally. It cannot be concluded that the blast furnace is necessarily inferior to the electric phosphorus furnace. Decisive economic factors are the costs of transported phosphate rock, and of energy; development of low-priced hydroelectric power during the last two decades, particularly in the Tennessee Valley, has been accompanied by considerable growth of electrothermal phosphorus production in the U.S.A. Another influential factor is the circumstance that a phosphorus blast furnace has to be large in order to be economical, whereas electrothermal phosphorus units are only marginally less efficient at a capacity of 2,000 tons of phosphorus per annum than at 20,000 tons. This gives a flexibility to the scale and capital cost of electrical manufacture well suited to recent conditions of change in the total requirement of phosphorus as an intermediate for chemical manufacture (as

p

inch (water-gauge) above atmospheric, and the seal in Aho stuffing boxes may be made by asbestos or sand or slag wool. The hearth consists of hard carbon blocks which extend also 2 or 3 ft, up the inside. Carbon is used because the molten silicate slag rapidly attacks refractory ceramic linings. The life of the hard carbon hearth and lining may be anything from nine months to several years; much depends upon strict attention to the correct proportion of carbon in the mixture charge to the furnace. Usually there is a firebrick lining outside the hard carbon, extending up to the top of the easing and under the roof. The outside steel shell is sometimes water-cooled by sprays. The furnace shown has a single tap-hole from which both slag and ferrophosphorus are drawn, but in large furnaces a second tap-hole at a lower level is sometimes used for withdrawing ferro-

phosphorus only. Tapping is done at intervals of a few hours, the tap-hole being plugged with clay when the slag stream ceases. When slag and ferrophosphorus are tapped together the two are separated by running the molten stream first into a catch-pot, from which the lighter slag overflows into a slag pit, or into a tank in which it is quenched and granulated with water.

The furnace is kept fully charged (although not full to the roof) by allowing the mixture to feed automatically down from an overhead bin through feed-hoppers in the furnace cover; the hoppers are arranged to give more or less an even depth of charge across the furnace. The feed pipes from the hoppers extend a foot or so below the underside of the roof, to ensure a free passage for the gases across to the outlet pipe.

The flow sheet of Fig. 2 indicates the quantitative aspect of the process, when good quality

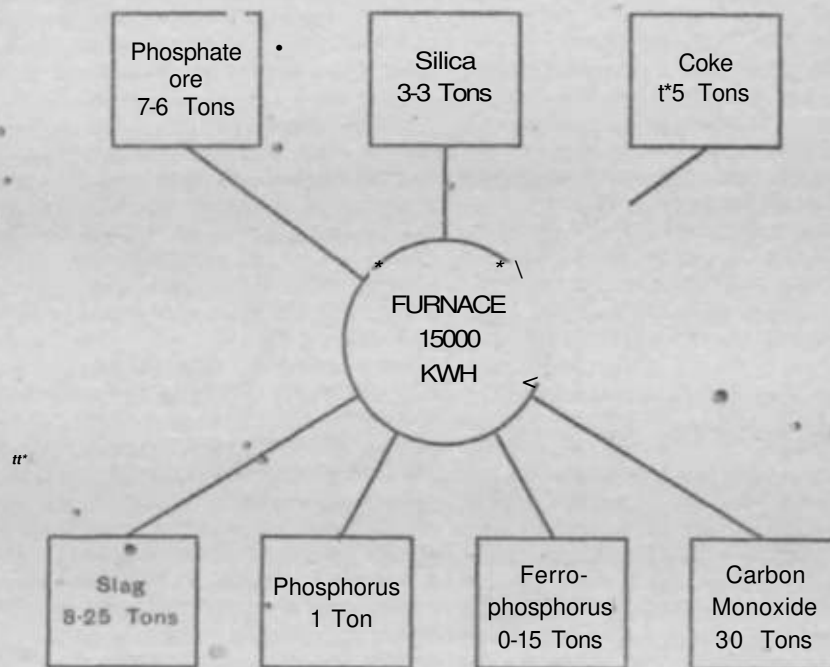

Fig. 2.

phosphate ore and coke are used. The ingredients of the furnace charge are, if necessary, dried before weighing.

Adequate porosity of the furnace feed is important, since a large volume of gas must continuously escape from the reaction zone deep in the furnace. The most satisfactory grading for the phosphate and silica is pieces of about 1/2 in., whilst the coke is usually 1/4-1/2 in. The coke and silica present no problem, but the phosphate from most mines is too fine or too friable to be used directly. It is "sintered" by a process introduced by Metallgesellschaft in 1928, the temperature being raised until incipient fusion binds the particles into a reasonably coherent mass which is cooled and crushed to size, the under-size being returned for reheating. Plant for the sintering operation is a moving belt with cast iron plates, which acts as a grate (Dwight and Lloyd continuous sintering plant is usual). The phosphate rock is mixed (moist) with fine coke and a little clay, fed to the moving grate,

and heated by oil or gas burners until the coke ignites and burns out under forced air draught. At the present time most of the phosphorus furnaces in the U.S.A. work on "wintered" or "nodulised" phosphate. (The latter term is applied to a heat treatment in rotary kilns, omitting the coke and firing by gas or oil.) In England and European countries the tendency has been to use Florida pebble phosphate or Russian Kola concentrates; the former can be used directly, the latter after sintering. From the point of view of phosphorus furnace operation there is little to choose between sintered and pebble phosphate of comparable phosphorus content, and the choice turns on availability and delivered price.

It is interesting that a substantial proportion (30-50%) of the fluorine is driven out of the fluorapatite in the sintering or nodulising operation. The conditions under which fluorine can be more nearly completely removed from fluorapatite have been studied at the Bureau of

Chemistry and Soils, Washington. It appears that by the action of steam on the phosphate ore at 1,400°C. 95% and upwards of the fluorine can be removed. Silica (which is present in most naturally occurring phosphates, and can be supplemented as required) assists materially. The phosphate product is a mixture of hydroxyapatite, tricalcium phosphate, and tetracalcium phosphate ( $\text{Ca}_4\text{P}_2\text{O}_9$ ) according to the conditions employed. The following papers may be consulted, where also references to other work will be found: D. S. Reynolds, K. D. Jacob, and L. F. Rader, *Ind. Eng. Chem.* 1934, 26, 406; D. S. Reynolds, K. D. Jacob, H. L. Marshall, and L. F. Rader, *ibid.* 1935, 27, 87; 1936, 28, 678; H. L. Marshall, D. S. Reynolds, K. D. Jacob, and L. F. Rader, *ibid.* 1935, 27, 205; also T. P. Hignett and T. N. Hubbuch, *ibid.* 1946, 38, 1208. This work on defluorination, done with the object of converting the non-accessible phosphorus pentoxide of natural fluorapatites into an available form for agriculture, is also interesting to the phosphorus manufacturer in connection with the properties of the furnace slag; for instance, fluorine is an undesirable constituent which militates in some way, not yet understood, against the use of phosphorus furnace slag as a basis for cement clinker.

Quartz and quartzites used in the industry vary from 85%  $\text{SiO}_2$  upwards. The raw materials are continuously weighed and roughly mixed before being fed into the furnace. The chemical reaction can be approximately formulated as

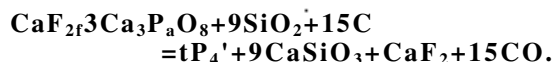

Any iron present in the raw materials is converted to ferrophosphorus, which forms a molten layer under the silicate slag. It is usual to keep the weight ratio of  $\text{CaO}$  to  $\text{SiO}_2 + \text{Al}_2\text{O}_3$  in the slag at about unity in the interest of smooth working of the furnace. Whilst lower ratios give more easily fusible slags and tend to improve the yield of volatilised phosphorus, the advantage is offset by increase in energy consumption because of the larger amount of molten slag produced, and a tendency to attack the lining of the furnace. Volatilisation of silica is not a serious problem in electric furnaces although the siliceous, carbonaceous, and phosphate dust carried by the furnace gases causes trouble (unless effectively removed from the gas stream). The dust mixes with the condensed phosphorus forming a difficult material referred to as "phosphorus mud"; this is usually returned to the furnaces or distilled in separate resistance-heated furnaces.

The gaseous reaction products are taken off through a wide pipe at the top of the furnace, to the condensers. The partial pressure of phosphorus vapour is about 60 mm. corresponding to a dew-point of about 175°C. Arrangements for cleaning the furnace gas from dust and for condensing vary somewhat; the plant items utilised up to 1945 by I.G. Farbenindustrie in the works of the Bayerische Stickstoffe A.-G. at Piesteritz in Germany are representative of good practice. They are described in a detailed report on the German phosphorus industry

(B.I.O.S. Report No. 562 (Item-22), 1946)\* The gas leaves the furnace at 250-300°C, and is passed dry through electrostatic precipitators well above the phosphorus dew-point. Each furnace is provided with a set of two electrostatic precipitators and three condensers all in series, the whole being duplicated for each furnace by a stand-by set. The shells of the condensers are of metal cooled externally by sprays and internally by shaft-driven rotating metal discs which dip into a water layer at the bottom of the condensers. A simpler type of condenser, consisting of a number of vertical towers in series, with internal sprays of warm water, is often employed. The water is kept above 44°C. so that the phosphorus remains molten and can be run to storage tanks. At this stage the condensed phosphorus is at least 99.8% pure. There is always some phosphoric acid in the internal condenser water because of slight oxidation of phosphorus in the upper part of the furnace and by dissolved air in the condenser water. Hydrofluosilicic acid is also present since a variable proportion (usually less than one-third) of the fluorine in the phosphate rock is volatilised as silicon tetrafluoride.

With high-grade raw materials the yield of phosphorus as element is 85-90% of the total charged to the furnace, with a further 2-5% in the recovered ferrophosphorus. Unvolatilised phosphorus remaining in the slag varies from 3-6%, and there is an "unaccounted-for" loss of 2-4%.

Treatment of the Phosphorus.—Arsenic and sulphur are invariably present in the raw materials, and both are found in the phosphorus, usually to the extent of 100-200 p.p.m. There are also traces of organic matter. For many purposes these impurities are unimportant, and the only purification of phosphorus sold as such is bleaching (by stirring with a hot acidified solution of sodium dichromate) and filtration. Treatment of molten phosphorus with fuller's earth or active carbon removes the organic matter and gives an entirely colourless product. Elimination of arsenic from elemental phosphorus is difficult. Some reduction is effected by steam distillation, but the claim for complete removal (E. Noelting and W. Feuerstein, *Ber.* 1900, 33, 2684) goes too far. Partial removal can be effected by vigorously shaking molten white phosphorus with yellow ammonium sulphide solution. Fortunately arsenic is quite easily removed from phosphoric acid and solutions of phosphates. White phosphorus of English manufacture is sold in the form of "wedges" made by casting under water into flat cylinders with star-shaped partitions, or as sticks made by casting or by drawing through glass tubes under cold water in the manner described by K. Seubert (*Annalen*, 1844, 49, 346).

By-products from Electrothermal Phosphorus Manufacture.—Carbon monoxide at 80-90% purity is obtained from the condensers. The principal impurities are nitrogen, water vapour, methane, carbon dioxide, hydrogen, and fractional percentages by volume of phosphorus and sulphur compounds. Part of the gas is sometimes used for drying and calcining the raw materials for the furnaces. A surplus is avail-

able as fuel or for conversion to chemical products.

Phosphorus furnace-slag, consisting essentially of calcium silicate, has typically the composition: CaO 47; SiO<sub>2</sub> 42; Al<sub>2</sub>O<sub>3</sub> 5; P<sub>2</sub>O<sub>6</sub> 1.5-2.5; F 1-3; Na<sub>2</sub>O+K<sub>2</sub>O+MgO 2-5%; Mn, Ti, S, C, As in traces. A variable proportion (it may be over one-third) of the ferrophosphorus corresponding to the iron content of the raw materials remains dispersed in the slag; the amount depends upon the location of tap holes and tapping procedure.

The slag is a potentially valuable commodity but a total in all countries of probably more than a million tons annually is dumped or used for road construction. Recently effort has been directed to finding outlets for it. The Tennessee Valley Authority has explored its use for agriculture, principally as a source of lime. Bulletin No. 184 from the University of Tennessee Agricultural Experiment Station\* (1943) entitled "Quenched Calcium Silicate Slag—a by-product Substitute for Limestone and Superphosphate," by W. H. MacIntire and S. H. Winterberg, describes the production of the slag in a suitable form, and the results of agricultural trials. The slag is quenched by high pressure water jets impinging on the molten stream as it falls over a weir, the result being a granular glassy product. Lime is readily released from this by hydrolytic action of soil moisture, and it is further claimed that the small phosphate content is also available, and that the fluorine in the slag is harmless to plants. Another use for the slag is conversion into "mineral wool" for insulation. By less drastic quenching a cellular product (foamed slag) has been made, useful for insulation or as a light-weight aggregate in concrete. Attempts to produce a hydraulic cement by raising the lime-silica ratio into the Portland-cement range have not been successful. It has been proposed to replace all or some of the silica in the furnace charge by bauxite to give slags consisting of calcium aluminate, or at least containing a considerable proportion of alumina; such slags are claimed as hydraulic materials (B.P. 264520, 285055, and 287036, to I.G. Farbenindustrie; G.P. 490803, to W. Schroder). Ferrophosphorus finds a market as a subsidiary material in the manufacture of steel. When demand exceeds supply, scrap iron can be added to the furnace charge. If supply persistently exceeds demand, the phosphorus content can be recovered as trisodium phosphate (U.S.P. 1888003 and 1926747, to Victor Chemical Works) by mixing finely ground ferrophosphorus with soda ash and heating in an air stream:

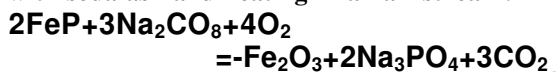

Another furnace by-product can be sodium silicofluoride, made from the silicon tetrafluoride dissolved out of the furnace gas in the condensers.

Attempts to devise furnace processes which would combine the manufacture of phosphorus with other products for which an outlet exists on a stoichiometrically relevant scale have appeared in patent specifications, but so far none appears to have been developed successfully. An interesting example is manufacture

of calcium carbide and phosphorus simultaneously by the reaction

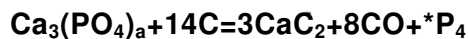

(G.P. 92838, 1895, to H. Hilbert and A. Frank). It is claimed that the calcium carbide, although unsuitable for acetylene manufacture (it contains calcium phosphide), can be used for making calcium cyanamide.

### III. MANUFACTURE OF PHOSPHORIC ACID.

Conversion of Phosphorus to Phosphoric Acid.—In some plants the whole furnace gas after removing dust is burnt; in others the phosphorus is condensed and burnt separately. The latter is the more usual at the present time. If the by-product carbon monoxide is used for its fuel value only, there is not necessarily any economy over the more direct process of burning the gas along with the phosphorus vapour. The utilisation of the heat of combustion of both phosphorus and carbon monoxide, together or separately, is a problem of chemical engineering design and of the balance between the cost and usefulness of steam on site versus capital amortisation. Until recently the recovery of the heat from combustion of phosphorus or furnace gas has been rather unimportant, but latterly the growth of the phosphorus industry together with its increasingly competitive character and the rising cost of coal is directing attention to the economy possible.

When the phosphorus is isolated and burnt separately, two procedures are possible. The phosphorus can be burnt in excess dry air, and the anhydride vapour condensed to the familiar white powder, which is then hydrated in a separate stage. Alternatively the hot gaseous product of phosphorus combustion in air can be treated directly with steam or water sprays. Both methods have been used successfully. The condensation of phosphorus pentoxide vapour to a satisfactory "snow" involves unusual problems of heat transfer. Large volumes and areas of condensation space seem to be necessary. B.P. 197863 (to R. Throfall) indicates some of the factors involved. When the hot gaseous products of combustion are hydrated directly, a mist of phosphoric acid droplets is formed, which can be separated from the accompanying nitrogen by filtration at high linear rates of flow through packed towers (W. H. Baskerville, Trans. Amer. Inst. Chem. Eng. 1941, 37, 83) or by electrostatic precipitation. A different method, avoiding formation of acid mist, is absorption of the hot phosphorus pentoxide vapour into concentrated phosphoric acid, which is cooled and re-cycled through the absorption tower with continuous addition of the stoichiometrically needed water and take-off of concentrated acid (J. H. Walthall and M. M. Striplin, Ind. Eng. Chem. 1941, 33, 995). The engineering difficulties encountered in the design of large-scale plant for converting phosphorus to phosphoric acid have been serious because of the high temperature and corrosive nature of the acid. Reference may be made to papers already mentioned and to H. A. Curtis, Trans.

sodium silicofluoride). A proportion of the phosphoric pentoxide content of the crude acid is lost in the precipitate (or must be re-processed). The consumption of filter aid, decolorising carbon, and barium carbonate for sulphate removal, together with evaporation and operating expense, has the effect (in regions where the industrial economy is based on coal) of bringing the manufacturing cost to about the level of the same salts made with acid from elemental phosphorus. The acid phosphates found in foodstuffs (chiefly acid calcium orthophosphate and acid sodium pyrophosphate) cannot be manufactured directly from crude wet-process acid, and there is no economical way of removing the impurities (particularly iron, aluminium, and fluorine) from the acid of acid salts, if the phosphate ore contains substantial percentages of these elements. \*

Details of process and plant for making phosphoric acid by continuous-flow "wet processes"

vary somewhat, but it does not appear that the cost and quality are much affected by differences in present-day operation. The application of the Dorr system of continuous counter current decantation to the separation of gypsum from the phosphoric acid was a marked advance over primitive batch drainers or filter presses; it produced phosphoric acid at about 20-24% of  $P_2O_5$ , with good extraction efficiency, and has been widely used for large-scale manufacture. More recently the size of plant required for a given output has been reduced, and the concentration of the acid obtained without evaporation has been improved somewhat, by the introduction of the Dorr "strong-acid" process (U.S.P. 2049032, 1936). The numerous decantation tanks and thickeners of the older process are replaced by two rotary filters and an intermediate re-slurrying tank; acid of concentration about 30%  $P_2O_5$  is produced before evaporation.

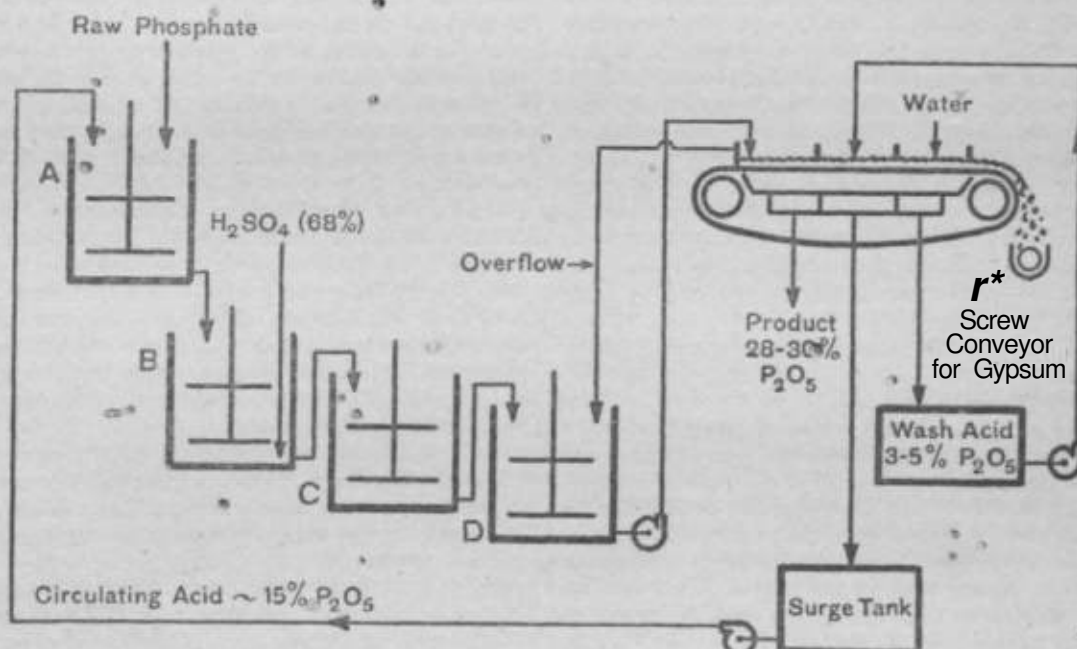

FIG. 3.

A type of filter originally designed specifically for phosphoric acid manufacture is the Landskrona belt, developed and used in the superphosphate factory at Landskrona, in Sweden. This filter, which is now in use in several countries, is described in B.P. 418075, 1934, and 457320, 1930 (both to Aktiebolaget Kemiaka Patenter); improvements in detail have since been incorporated as a result of operating experience.

The following brief account describes one form of modern practice in the production of phosphoric acid by the "wet process" or "sulphuric acid process." The plant arrangement is indicated diagrammatically in Fig. 3. Phosphate ore of almost any origin can be used. The ore is ground so that 90% passes 100 mesh, and is fed by a screw into vessel A, where it is mixed with dilute phosphoric acid derived from the filter. Little reaction occurs in this vessel, its main purpose being to provide a suitable slurry

to which sulphuric acid can be added without unduly violent reaction or excessive frothing. Frothing occurs with ore\* containing a proportion of carbonate; its extent is a function also of the organic matter content of the ore, and is most marked with African phosphates. The slurry from vessel A overflows continuously into a second mixing vessel B where sulphuric acid at 65%  $H_2SO_4$  is added. The heat of reaction maintains the temperature here at  $80^\circ$ . The slurry flows through two further stirred vessels C and D from which it is pumped on to the belt filter. The volume of slurry contained in these vessels is so related to the through-put as to allow a reaction time of eight hours, which extracts about 97-98% of the  $P_2O_5$ . Usually about one-quarter of the fluorine vaporises as hydrogen fluoride and silicon tetrafluoride from the reaction vessels. The filter cloth is carried on a thick endless rubber belt constructed in the form of a shallow trough (Fig. 4), ribbed and

Amer. Inst. Chem. Eng. 1935, 31, 278; H. A. Curtis, Chem. Met. Eng. 1935, 42, 320; H. A. Curtis and A. M. Miller, *ibid.* 1936, 43, 408; H. A. Curtis, A. M. Miller, and B. H. Newton, *ibid.* 1938, 45, 193; U.S.P. 2272402, 1942, to Monsanto Chemical Co.

The possibility of preferentially burning the phosphorus vapour in the furnace gas to phosphorus pentoxide without oxidising much of the carbon monoxide has been examined by G. L. Frear, E. F. Ogg, and L. H. Hull (Canad. Chem. 1942, 26, 268) and appears to be feasible. G.P. 449585 and 475128 (to W. Kyber) claim the application of this effect to the production of phosphoric acid and high-grade generator gas, by mixing with the gas obtained from a phosphorus blast furnace just sufficient air to oxidise the phosphorus only. The proposal is extended to the oxidation of phosphorus vapour at high temperature by carbon dioxide, which is reduced to carbon monoxide. A cognate question is the nature of the gas-phase equilibria among the species  $P_2$ ,  $P_4$ ,  $P_4O_6$ ,  $(P_4O_4)_n$ ,  $P_4O_{10}$ , and  $CO$  and  $CO_2$ , which has been examined in a preliminary manner by E. V. Britzke and N. E. Pestov, Trans. Sci. Inst. Fertilisers (U.S.S.R.), 1929, No. 59, 5, and by P. H. Emmett and J. F. Schultz, Ind. Eng. Chem. 1939, 31, 105. Contrary to claims in several patents that phosphorus vapour can be completely oxidised by carbon dioxide to phosphorus pentoxide, it is clear from the work of these authors that the reaction (in the neighbourhood of 1,000°C.) tends to an equilibrium involving  $(P_2O_4)_n$  as well as  $P_4O_{10}$ . Emmett and Schultz, however, show that if the  $P_4O_{10}$  is removed from the gas phase, as for example by reaction with calcium phosphate to form calcium metaphosphate, complete oxidation to 'quintivalent phosphorus' is possible, and they suggest the possible application of this to the simultaneous production of a concentrated fertiliser and hydrogen by interaction between the carbon monoxide and water vapour, and re-cycling the carbon dioxide from the water-gas conversion. Reference may be made here to a description by H. A. Curtis, R. L. Copson, A. J. Abrams, and J. N. Junkins (Trans. Amer. Inst. Chem. Eng. 1938, 34, 287) of the full-scale production by the Tennessee Valley Authority of calcium metaphosphate, employing, however, the gaseous product of combustion of phosphorus alone in air. The manufacture of calcium metaphosphate in this way was introduced by the Aussig Verein in 1929 (Czech. P. 38892; F.P. 712589).

Treatment of the Phosphoric Acid.—All variants of the phosphorus combustion process give hot concentrated acid in the first instance, which is bleached, if necessary, before cooling, de-arsenicated, and filtered and diluted to a definite concentration.

Methods of de-arsenication applicable to concentrated acid include: (a) treatment with hydrogen sulphide or sodium sulphide, preferably at 70-80°C. To avoid having the whole volume of the viscous acid to filter the I.G. Farbenindustrie (S.I.O.S. Report No. 562 (Item 22), p. 41) add mineral oil and blow with air, so that the arsenic sulphide collects in the froth; the flotation layer is filtered with kieselguhr and

carbon black as filter aid. (b) Electrolysis of the concentrated acid, the arsenic being in part reduced to arsine, in part deposited on the cathode, which is separated from the anode by a diaphragm. This method lends itself to continuous-flow operation, and the consumption of platinum at the anode is not excessive, although the initial cost is high. Small particles of arsenic occasionally flake off from the cathode, and rough filtration is necessary to retain them. The addition of copper to the acid to aid in the electrolytic removal of the arsenic is recommended, (c) The Monsanto Chemical Co. (U.S.P. 2287683, 1942) describes another method applicable to viscous acid, even up to a concentration as high as tetraphosphoric acid,  $H_6P_4O_{13}$ . The acid is heated to about 105°C. and passed through a vessel packed with thin copper foil. The arsenic is converted into a black coating of copper arsenide on the copper surface; fragments of the coating which become dislodged are retained by a coarse filter. It is claimed that the presence in the acid of 0.01-0.2% of hydrochloric acid almost entirely prevents solution of copper in the acid, provided that air is excluded. (d) Other chemical methods of reducing the arsenic to the elemental condition are applicable. These are mentioned in connection with "wet-process" acid.

In England phosphoric acid is marketed as acid of density ( $\rho$ ) 1.750 at 60°F., corresponding to 65.03% of  $P_2O_5$ ;  $\rho$  1.650, corresponding to 58.82% of  $P_2O_5$ ; and  $\rho$  1.500, corresponding to 48.71% of  $P_2O_5$ . In bulk the acid is transported in stainless-steel tanks, smaller quantities being carried in crated glass carboys. Although the acid at  $\rho$  1.750 is theoretically liable to crystallise at any temperature below 28°C., in practice the tendency to remain supercooled is so strong that freezing occurs only in very cold weather. The acid can be melted by standing the glass carboys in warm water, with remarkably few casualties.

Wet-process Phosphoric Acid.—In the "wet process" raw phosphate is decomposed by sulphuric acid under conditions which ensure the reaction

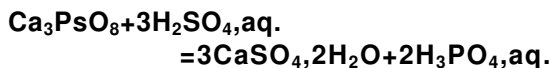

Compared with combustion of electrothermal phosphorus or furnace gases, the wet process can produce phosphoric acid more cheaply per unit of phosphorus pentoxide content, except where electric power is available at exceptionally low cost. On the other hand, the acid is very impure, and unless concentrated by evaporation does not usually contain more than 30% of  $P_2O_5$ , often less. An important use of crude phosphoric acid from the wet process is in the manufacture of concentrated phosphate fertilisers, including to an increasing extent "triple" superphosphate, and for this purpose the impurities are not of primary importance. When the crude acid is used for making alkali phosphates such as di- and tri-sodium phosphates the impurities are in part eliminated as insolubles (iron, aluminium, and calcium phosphates, and in part the fluorine as cryolite or



perforated for liquor flow. The belt runs over cast iron or rubber-lined drums at both ends of the filter. Approximate dimensions and operating data for a filter with a capacity of 50 tons of acid per 24 hours (at a concentration of 25-28% of  $P_2O_5$ ) are: filtration area 3 sq. m.; belt width 1 m.; diameter of pulleys 1 m.; belt speed 0.5-1 m. per min.; thickness of gypsum cake, up to 10 cm.; suction is maintained in the suction boxes at about 26 in.; temperature of acid slurry at the feed end of the belt, 60-70°. The washed gypsum falling off the belt carries 40-60% of water. The filter cloth is of wool, and is stretched over the rubber belt, but is not attached to it. The life of a woollen filter cloth is about 100 hours; 2 hours is required for replacement. The best material for the belt is natural rubber, and the life is several years. The suction box (fabricated from molybdenum-bearing stainless steel or rubber covered steel) is divided into three sections, giving three zones of action on the belt. In the first zone the hot slurry is pumped on to the belt, the excess flowing back over a weir and returning to the vessel D and circulating system. The gypsum cake forms at a thickness (4 in. is usual) controlled by a shutter. The filtrate from this section is the

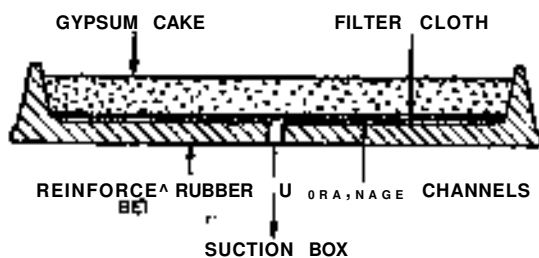

FIG. 4.

process product. By carrying the filter on a platform, a barometric leg is inserted between the suction box and the tanks which receive liquor from the three sections of the box. The second zone is sprayed with weak acid derived from the third section, and the filtrate from this section is returned to the first mixing vessel A. The third zone is sprayed with water, the filtrate carrying about 4% of  $P_2O_6$ . The concentration of the finished product from the belt is in practice sensitive to the quality of the phosphate ore, phosphate with 25% of  $P_2O_6$  giving acid at 26-27%  $P_2O_6$ , whereas with phosphate at 23%  $P_2O_6$  the acid concentration drops to 23-24% of  $P_2O_6$ .

The mixing vessels, provided with powerful agitating paddles and internal baffles to improve the turbulence, are constructed of lead-lined wood or homogeneously lead-lined steel. An excess of sulphuric acid is used in the process, so that the recirculated phosphoric acid returned from the second zone of the filter to vessel A maintains there a small free sulphuric acid concentration; in the other mixing vessels there is rather more free sulphuric acid. When the plant is working without interruption, the lead linings are fairly effectively protected by a film of lead sulphate.

The operating conditions throughout the process are controlled to ensure the highest efficiency

of filtration and washing. Details of filtration rates and relative quantities of recirculated acid and acid finally produced are explained in B.P. 457163, 1936 (to Aktiebolaget Kemiska Patent, Landskrona). The gypsum is in the form of narrow monoclinic crystals mostly about 30-70  $\mu$  long, often twinned so that they appear "swallow-tailed" at one end. It is usual to use about 2% excess sulphuric acid, which is advantageous in improving the extraction efficiency of phosphorus pentoxide from the ore, and in reducing the percentage of calcium in the phosphoric acid. The cake on the filter cloth is kept covered with liquid at all places except over about the second half of the third zone; continuous attention is given to see that the flow of liquids is not too fast, resulting in flooding over the sides of the belt, nor too slow so that the cake sucks dry and cracks. The efficiency of the washing is good, and the wet cake (discharged from the belt with about 60% of solids) carries in soluble form as little as 1% of the total phosphorus pentoxide charged to the process, in addition to the 2-3% of so-called "insoluble" phosphorus pentoxide. Bringing into account & loss in grinding of about 1%, and slight losses by leakage of acid liquora, the overall recovery of phosphorus pentoxide is 94-95%.

Attempts have been made, including the full scale, to produce more concentrated acid directly from the filtration stage by working at higher temperatures and concentrations, and even by treating the ground ore with sulphuric acid in autoclaves. Most of the schemes described involve either anhydrous calcium sulphate or the hemi-hydrate (B.P. 314976 and 314977, 1930, to Aktiebolaget Kemiska Patent, Landskrona).

On the filters, less hydrated forms of calcium sulphate than gypsum are troublesome because of rehydration and slow washing. A process has been described which involved producing the hemi-hydrate initially, filtering, then converting to di-hydrate and filtering again. However, processes not involving the direct production of gypsum are not now recommended. A possible exception to this generalisation is a process patented by the Southern Phosphate Corporation which is described in a later paragraph in connection with the removal of impurities from crude phosphoric acid.

A typical analysis of the crude acid from a high-grade Florida pebble phosphate is: total  $P_2O_5$  280,  $SO_4$  1.8,  $SiO_2$  0.35,  $Fe_2O_3$  0.8,  $Al_2O_3$  1.0, F M, As 0.005, Pb 0.0015, CaO 0.08%. The CaO content is fairly constant if the  $SO_4$  is kept steady, but the  $Fe_2O_3$ ,  $Al_2O_3$ , and F vary considerably according to the type of ore used. The colour of the acid is dark brown from Florida phosphate, brown from Russian and Swedish apatite, and green from Moroccan phosphate. The arsenic is derived partly from the ore and partly from the sulphuric acid used. Besides the impurities mentioned, there are traces of other elements (W. L. Hill, H. L. Marshall, and K. D. Jacob, Ind. Eng. Chem. 1932, 24, 1064); in part, these enter with the sulphuric acid used, and from the materials of construction of the plant. Traces of vanadium are present in many phosphate ores, and



Impart a blight green colour to the crude acid, which is not removed by active carbon. Some ores, especially those mined in the west of North America, contain enough vanadium to make its elimination from the acid desirable and possibly even directly profitable.

Difficulties which are encountered in the concentration of crude phosphoric acid arise from its corrosive nature (much worse than pure phosphoric acid at equivalent strength), and on evaporation deposition of seal? on the heating surface, and evolution of hydrofluoric acid and silicon tetrafluoride. For some purposes concentration of the free acid can be avoided, the necessary evaporation being done on the solution of a soluble salt of the acid, which is alkaline or at worst only weakly acid. On the other hand, evaporative concentration goes some way towards purifying the acid, since much of the fluorine, sometimes all of the silica, and most of the calcium, along with some of the sulphate, are eliminated. The scale which forms contains Ca, Fe, Al, SO<sub>4</sub>, PO<sub>4</sub>, and F, but no SiO<sub>2</sub>. For fertiliser purposes, when the removal of impurities during the concentration is of subsidiary importance to economy of fuel and simplicity of plant, submerged combustion with stainless steel burners is applicable. An alternative method is by blowing hot air or combustion products at 200-300° o. through a number of nozzles of hard lead (or carbon) dipping just below the surface of a shallow stream of the acid, in a long trough-shaped enclosed chamber, preferably constructed of homogeneously lead-lined steel or of acid-resisting brick. One of the most resistant materials to attack by phosphoric acid is carbon, either as hard carbon or as graphite. The porosity difficulty is overcome by impregnation with acid-resistant thermo-setting resin. Tubes and vessels can be made from such non-porous graphite which have excellent heat conductance, and multi-effect evaporators of normal design have become possible.

**Purification of "Wet-process" Phosphoric Acid.**—Several patents describe methods of removing or reducing particular impurities. U.S.P. 2165100, 1939 (to the Virginia Chemical Corporation) gives a method and apparatus for reducing the fluorine content to less than 50 p.p.m. by blowing superheated steam through a carbon or silica diffusion disc submerged in acid of not less than 50% P<sub>2</sub>O<sub>5</sub> content. U.S.P. 1487205, 1925 (to J. N. Carothers and A. B. Gerber) proposes the removal of fluorine by addition of sodium silicate to the crude acid, followed by filtration through a sand filter. Vanadium can be removed by addition of a soluble ferrocyanide, which precipitates some of the iron present along with all of the vanadium (U.S.P. 1544911, 1925, to F. Laist). Arsenic can be removed as sulphide by treatment with hydrogen sulphide or addition of a small quantity of sodium sulphide. The precipitation is best done at 40-60° o.; excess hydrogen sulphide is removed by blowing air or inert gas through the liquid, and the arsenic sulphide filtered out.

Other methods involve reduction of the arsenic to the elemental condition; it is claimed that this can be done by the use of phosphorus hydrides (G.P. 413377; B.P. 234122, to E. Merck).

A process for making purified phosphoric acid has been described by the Southern Phosphate Corporation (B.P. 664574, 1944) which utilises sulphuric acid but differs considerably from the usual conception of the "wet process." It is claimed that 95-98% of the fluorine is eliminated, and also the iron and aluminium. Ground phosphate ore is mixed with 70% phosphoric acid obtained from a later stage in the process, the temperature being raised partly by the exothermic reaction, partly by external heating, to 125° o.; the proportions and time of mixing of the ore and phosphoric acid are such that a dry solid is obtained with CaO/P<sub>2</sub>O<sub>5</sub> in molecular ratio between 1 and 0.5. This mixture is then calcined at a temperature between 350° and 400° c. Fluorine is liberated during all stages of the heating. Under these conditions iron and aluminium metaphosphates are formed, and are not soluble in the next stage of the process; at the same time organic matter is thoroughly charred. In the next stage, the calcined product is digested with 100% orthophosphoric acid (obtained from a further stage of the process) by stirring and heating to 150° o. After the acid calcium metaphosphate has been dissolved, concentrated sulphuric acid equivalent to the calcium is added along with more phosphoric acid less concentrated than 100%, so that the phosphoric acid concentration in the reacting mixture is 100%. A portion of this is taken for recycling, the remainder being diluted to about 75% and filtered on a rotary filter. It is claimed that the calcium sulphate present does not rehydrate readily; the iron and aluminium metaphosphates are filtered out along with charred organic matter, calcium sulphate, and any other insoluble materials. The filter cake is then washed with water and the resulting dilute phosphoric acid is used in earlier stages. The patent describes quantitatively various applications of the principle involved. Except for fluorine, no data are given to show the extent of elimination of impurities, but the process is such that residual quantities of these, and also sulphate, should be much lower than in the usual forms of the wet process. It may be noted that purification of phosphoric acid from iron and aluminium by taking advantage of the insoluble character of their metaphosphates after the crude acid had been heated between 320° and 360° o. was originally proposed by W. Gregory (Annalen, 1845, 54, 94).

Apart from the manufacture of acid calcium phosphate for inclusion in foodstuffs, the most important commercial use of purified phosphoric acid is in the production of mono-, di-, and tri-sodium orthophosphates, and also meta-, pyro-, and poly-phosphates obtained by elimination of the elements of water from anhydrous mono-, di-, or mixed mono- and di-orthophosphates of sodium. Pure monosodium phosphate occupies a key position in this group of sodium compounds, since all the others can be easily obtained from it by thermal treatment alone or by addition of sodium carbonate and caustic soda followed by thermal treatment if required. It is fortunate therefore that monosodium orthophosphate readily yields good crops of clean crystals. An interesting example which includes

utilisation of this circumstance is described in U.S.P. 1961127, 1934 (to The Warner Chemical Co.), concerned with the manufacture of disodium phosphate. The process starts with ground phosphate rock, which is decomposed by a deficiency of dilute sulphuric acid and filtered, so that about one-quarter of the phosphate is in solution as acid calcium phosphate, the remainder as free phosphoric acid. Sodium sulphate just in excess of the calcium present is added, and after filtration of gypsum together with a little sodium fluosilicate, soda ash is added to form a solution of monosodium-phosphate. At this stage a large precipitate forms containing iron and aluminium phosphate, together with some fluorine as either cryolite or additional sodium fluosilicate; it is claimed that recovery of the phosphate value from this precipitate is more economical than from the corresponding precipitate in the ordinary "wet process." The hot clear filtrate is crystallised and evaporated as necessary to give successive crops of monosodium phosphate; ultimate mother-liquor containing some accumulated sodium sulphate or acid calcium phosphate is returned to the process at the stage where calcium sulphate is precipitated. It is claimed that the mother-liquors do not contain impurities which interfere with the purity of the crops of monosodium phosphate, except that occasional purging of sodium chloride accumulation may be necessary. It should be remarked, however, that arsenic must be separately removed if its presence is undesirable, and that residual fluorine in the monosodium phosphate solution will be distributed between the crops and their mother-liquors rather evenly. It is probable that most manufacturers who crystallise monosodium phosphate as a pure chemical, dispose of the mother-liquors by conversion to di- or trisodium phosphate for detergent purposes, whereby some further precipitation of impurities is possible.

The manufacture of sodium phosphates from "wet-process" phosphoric acid is an important section of the phosphate industry. Detailed information is not generally accessible concerning the methods currently used by different manufacturers for removing the bases introduced along with the acid. When sodium carbonate is progressively added to the crude acid, a series of consecutive precipitation and re-solution reactions occur. From pH 1.2 ferric iron is precipitated as  $\text{FePO}_4$  until the pH has been increased to 2.2, after which hydrolysis to hydrated ferric oxide, accompanied by re-solution of the phosphate anion, begins, and is complete at about pH 9. Aluminium is precipitated as  $\text{AlPO}_4$  from pH 2.7 and re-solution of the phosphate anion occurs from pH 3.7 upwards. At much higher pH values, certainly above 8, the acidity of hydrated aluminium oxide causes re-solution of aluminium also. Precipitation of calcium and magnesium phosphates begins below pH 5.3 and 7.5, respectively. Little re-solution of phosphate anions from the calcium phosphate occurs below pH 11, but there is rapid passage of phosphate into solution from magnesium phosphate above pH 10.5. Reference may be made to a study of the solu-

bility equilibria involved (with special reference to the fate of phosphate in the soil) published in 1930 by T. Gaarder, "Die Bindung der Phosphorsäure im Erdboden," in *Meddelelser fra Vestlandets Forstlige Forsoksstation*, Vol. 4, Part 4 (Bergen).

Uses.—Phosphoric acid made by the "wet process" is mainly used in the manufacture of double or triple superphosphate or other phosphate fertilisers. In addition a considerable amount is consigned in the production of detergent phosphates. The stronger acid obtained by burning phosphorus is also used for making very concentrated phosphate fertilisers, in regions where the cost of transport to the consumer is an important item and the cost of electric power is sufficiently low.

Outside the fertiliser field, by far the greater part of the phosphoric acid made is converted to acid calcium phosphate and acid sodium pyrophosphate of foodstuff quality; the group of sodium phosphates used for detergent purposes and water treatment; ammonium phosphates, for yeast food and fireproofing; dicalcium phosphate and calcium hydroxyphosphate. Other applications include pickling of steel; manufacture of acid manganese and acid zinc phosphates for rust-proofing; yeast, penicillin, and other fermentation processes; gelatin and sugar manufacture; tonic medicines and phosphate drinks; activated carbon manufacture; textile dyeing; removal of milk-stone from dairy equipment. Frequent proposals in patent literature and otherwise are made for the use of phosphoric acid in preparing silage; in electrolytic metal polishing; as a catalyst for condensation and polymerisation reactions; for latex coagulation.

#### IV. RED PHOSPHORUS.

The discovery of red phosphorus is generally credited to A. Schrötter, the first investigator to demonstrate experimentally the allotropic relation of red to white phosphorus (*Sitzungsber. Akad. Wiss. Wien*, 1848, 1, 130). J. J. Berzelius (1843) suggested, but without proof, that the red substance produced by sunlight acting on white phosphorus is merely another form of phosphorus. The historical point\* over which there was some controversy, was discussed by J. Nicklés (*Compt. rend.* 1856, 42, 646) and by M. Kohn (*J. Chem. Educ.* 1944, 21, 522).

Physical Properties.—The allotropic relation of red to other forms of phosphorus has already been discussed in part (*v. Allotropic Forms*, p. 483c). The phase equilibrium diagram of white and red phosphorus is illustrated schematically in Fig. 5.

Curve EO is the vapour-pressure curve of solid red phosphorus, ending at o in the triple point ( $590^\circ\text{C}$ .; 43 atm.) at which red phosphorus melts to a yellow liquid. To the right of o lies the vapour-pressure curve of molten red phosphorus, which has been followed up to  $634^\circ\text{C}$ ., 59 atm. The vapour-pressure curve of the liquid has been followed down to  $504^\circ\text{C}$ ., 23 atm., the section cz' representing this supercooled liquid in equilibrium with phosphorus vapour and metastable with respect to red phosphorus.

The most reliable vapour-pressure measurements on red phosphorus are probably those of A. Smits and S. C. Bokhorst (Z. physikal. Chem. 1916, 91, 249) who found for solid red phosphorus

$$\log_{10} p \text{ (mm.)} = -5.667 - 7/y + H0844$$

where  $653 < r^0 \text{K.} < 863$ .

For molten red phosphorus (identical with molten white phosphorus) the vapour-pressure formula already given (v. supra) supersedes that of A. Smits and S. C. Bokhorst, and covers a greater temperature range.

The curve BZ is the vapour-pressure curve of molten white phosphorus, which has been measured from the melting-point of white phosphorus (44.25°C, 0.181 mm.) up to about 400°C.; a practical limit to the possibility of measurement beyond this point is set by the increasing rapidity of the change from white to red phosphorus. The section zz' is hypothetical—there is here a gap of about 100° in which no equilibrium pressure has been measured. Careful study of the sections BZ and Z'CD leads to the conclusion that they are in all probability parts

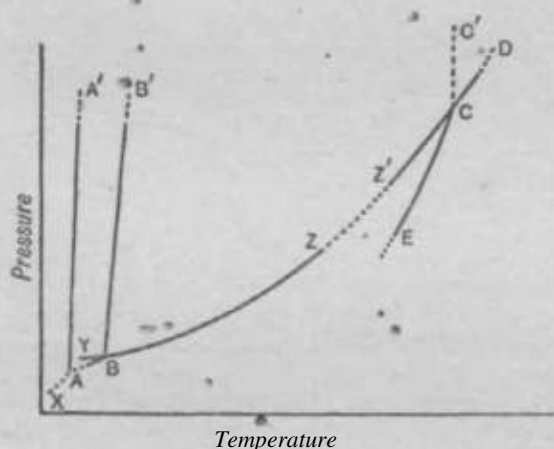

Fig. 5.

of a single vapour-pressure curve, that of molten red phosphorus, so that molten white phosphorus is to be considered as being also supercooled red phosphorus. The equation of this curve has already been given (v. White Phosphorus, p. 486a). The critical temperature and pressure which terminate the curve OD lie in the region of 700°C. and 82 atm., respectively. It was realised, long before the results of X-ray investigations of the structure of red phosphorus were available, that the slow transformation of white to red phosphorus, the physical properties of the latter, and the identity of the vapour in equilibrium with white or red phosphorus, were most readily intelligible on the supposition that red phosphorus is a highly polymerised form.

Curve BA is the vapour-pressure curve of solid white phosphorus (cubic) down to the transition temperature at -77° where change to the hexagonal variety occurs. The steep curves AA' and BB' represent the effect of pressure on the transition temperature and the melting-point, respectively, VB is the vapour-pressure curve of liquid white phosphorus, here supercooled with respect to both cubic white phosphorus and red phosphorus, and XA is the vapour-

pressure curve of hexagonal white phosphorus, oo' represents the effect of pressure upon the melting-point of red phosphorus.

The more important experimental studies of the equilibrium behaviour of phosphorus at high temperature are by the following authors.\* W. Hittorf (Pogg. Annalen, 1805, 126, 193); L. Troost and P. Hautefeuille (Ann. Chim. Phys. 1874, [v], 2, 1+5); P. Jolibois (Compt. rend. 1909, 147, 287; 1910, 151, 382); A. Smits and S. C. Bokhorst (Z. physikal. Chem. 1916, 91, 249); W. Marekwald and K. Helmholtz (Z. anorg. Chem, 1922, 124, 81); IX L. Chapman (J.C.S. 1899, 75, 784); A. Stock and F. Gomolka (Ber. 1909, 42, 4510); A. Stock and E. Stamm (ibid. 1913, 46, 3497); W. A. Wail (Meddelanden fran Finska Kemist-Samfundet, 1913, p. 3).

Heat Capacity of Red Phosphorus.—For the mean atomic heat  $C_p$  from 22 to 300°C. and to 500°C, respectively, the values 601 and 6.82 g.-cal. per °C. are given by O. Knbaschewski and G. Schrag (Z. Elektrochem. 1940, 46, 678). From 16 to 98°C., V. Regnault (Ann. Chim. Phys. 1853, [iii], 38, 129) found 5.27. Somewhat inconsistent with those values are measurements by A. Wigand (Ann. Physik, 1907, [W], 22, 64) in the temperature range 0-199°C. Measurements in the temperature range -252.75° to -195.7°O. gave  $\bar{O}_j = -1.34 \pm 0.04$  g.-cal. per °C. (J. Dewar, Proc. Roy. Soc. 1913, A, 89, 158).

In contrast to these equilibrium studies, a kinetic study of the vaporisation and condensation of red phosphorus has been made by H. W. Melville and S. C. Gray (Trans. Faraday Soc. 1936, 32, 271, 1086). Although there are unfortunately obstacles to accepting fully the authors' quantitative results, these experiments in the low-pressure range provide stimulating insight into the kinetic chemical behaviour of the species  $P_2$  and its relation to red phosphorus. It is concluded *inter alia* that red phosphorus depolymerises directly to  $P_a$ , and, that  $P_B$  molecules striking a surface of cold red phosphorus combine with it to form more red phosphorus.

Manufacture.—The change, on heating, of white phosphorus into red is greatly accelerated by addition of small quantities of certain substances, notably phosphorus di-iodide, sulphur, selenium, or sodium. In practice, however, it is not an advantage to use any catalyst. Although the literature contains a considerable volume of discussion of this allotropic change, neither the catalysed nor the uncatalysed reaction is understood from the mechanistic viewpoint. The visible phenomena are clearly described in the following quotation from T. W. DeWitt and Sol Skolnik ("Conversion of Liquid White Phosphorus to Red Phosphorus. I, Kinetics of the Reaction," J. Amer. Chem. Soc. 1946, 68, 2305).

"There are several qualitative aspects of the conversion of liquid white phosphorus to red phosphorus that are informative. The reaction mixture remains fluid until about 50% conversion is reached. On further reaction the mixture rapidly becomes viscous, passes through a plastic or mud-like stage, and finally solidifies. Below 50% conversion the reaction mixture contains suspended particles of red phosphorus large

enough to settle rather rapidly on standing. Even at 6-10% conversion, many of the particles have diameters of 20-30 microns. Apparently these particles of red phosphorus grow both in size and number until, in the region of 50% conversion, they begin to touch one another and grow together to form an interlocking mass. When it is considered that uniform touching spheres with cubic packing have about 50% free volume and that the density of red phosphorus is only about 20% greater than that of white phosphorus, it is quite understandable that, in the neighbourhood of 50% conversion, further growth of the particles requires that they grow into one another to form a more or less rigid structure. The appearance of large particles, even in the early stages of the reaction, is an important fact for which any postulated mechanism must account."

A similar description is given by Schrötter himself in his original communication in 1848.

The more important physicochemical facts relevant to manufacture are these: the formation of red phosphorus is exothermic by approximately 16 kg.-cal. per g.-mol. of  $P_4$ , whilst the latent heat of vaporisation of white phosphorus is approximately 10 kg.-cal. per g.-mol. of  $P_4$  at the boiling-point ( $280^\circ\text{C}$ ). The uncatalysed reaction is kinetically first-order with respect to white phosphorus, the rate-controlling step being uninfluenced by the presence of red phosphorus or even by nuclei of the nascent red-phosphorus phase at any stage of the conversion. The first-order velocity constant is  $k = (4.17 \times 10^{12}) \exp.(-37,800/RT)$  reciprocal minutes (T. W. DeWitt and Sol Skolnik, *l.e.*).

A batch conversion process has been widely used because of the simple and robust nature of the plant required. The actual conversion is done in a cast-iron or steel pot holding a 1-ton charge of phosphorus. Molten phosphorus is run in from a storage tank, under a shallow layer of water which later distils out. The pot is closed by a well-fitting lid luted and clamped down. The lid is provided with a vapour escape pipe sealed under water, and with thermocouple pockets. The pot, surrounded by a brick setting, is heated externally by gas or electricity in accordance with a definite schedule of time and temperature. Careful control of the heat input is essential, particularly when the heat of reaction begins to increase the rate of rise of temperature, to avoid vaporising out of the pot an unnecessary amount of phosphorus. The need for caution during the active stages of the conversion is evident from the data given above. For example, suppose that the phosphorus is 60% converted and the temperature is  $280^\circ\text{C}$ . The mass has become semi-rigid. From the velocity constant it is seen that the remaining 40% of white phosphorus is changing at the rate of about 2 mg. per minute for each g. of total phosphorus present. The specific heat of the phosphorus mixture is 0.2, so that the reaction is producing enough heat to raise the temperature about  $1^\circ\text{C}$ . per minute and if the temperature does rise, the whole process will accelerate because of the considerable temperature coefficient of the reaction. Violent eruption of vapour breaking through the solid mass is a

likely consequence. Provided that the conversion speed does not get out of control, a short reflux condenser attached to the escape pipe will return most of the vaporised phosphorus to the pot. When the conversion is complete, or nearly so, the external heating is increased so that the temperature of the red phosphorus is held for some hours somewhat below the temperature ( $420^\circ\text{C}$ .) at which the vapour pressure of red phosphorus reaches 1 atm.

When cold, the pot contains a hard and rather brittle mass of dark red to violet phosphorus, which is swamped with water and cut out. This mass exhibits no visible crystalline character when broken, and the contrast with this respect with a fracture surface of white phosphorus is probably the reason for the commercial name "amorphous phosphorus" which is still common in English-speaking countries. At this stage the product still contains traces of white phosphorus, and is liable to ignite spontaneously, if it is ground wet, and boiled with sodium carbonate solution until all white phosphorus is destroyed. The red phosphorus is then sieved wet (the oversize material being re-ground), filtered and washed on a rotary filter, and dried in vacuum. The dry cake is brushed through a sieve and packed into tins or steel drums.

A process employing gas-heated ball-mill converters was used by the I.G. Farbenindustrie at Bitterfeld in Germany up to 1945 (B.I.O.S. Report No. 562 (Item 22) gives a detailed description). A batch of phosphorus was 4,000 kg., and the cycle of operations required 3 days. Steel balls of 10, 12, and 14 cm. diameter were used; mill r.p.m. 14. Before charging with white phosphorus, air is displaced from the mill by inert gas. The mill is connected to a water seal until the white phosphorus has been at  $180-190^\circ\text{C}$ . for 2 hours, to dry out any water present. It is then closed completely, and the phosphorus temperature raised in a further 20 hours to  $270^\circ\text{C}$ . Thereafter the exothermic reaction raises the temperature during a further 4 hours to  $290^\circ\text{C}$ , the internal pressure rising to 2 or 3 atm. When the exothermic stage is finished, heating is recommenced, and the temperature taken up to  $360^\circ\text{C}$ . for 5 hours. The red phosphorus contains less than 0.1% of white phosphorus, which is removed by boiling with dilute caustic soda solution. An earlier description of a conversion process, based on a gas-heated ball-mill with iron or porcelain balls, is given in Russ. P. 35829, 1934 (to M. D. Senilov and A. A. Shalabanov).

The chief advantage that ball-mill processes have over the older procedure of heating a stationary charge of phosphorus, lies in the avoidance of the unpleasant operation of cutting and digging the hard mass of red phosphorus out of the pot. Another process has been patented which also avoids the cutting-out operation (U.S.P. 2397951, T. W. DeWitt, to the Tennessee Valley Authority, 1946). In this process, conversion to red phosphorus is continued only to a stage (about 50%) at which the substance is still liquid enough to be pumped. The removal of the unconverted phosphorus is effected by distillation in vacuum or in an inert gas, the still pot

being equipped with an agitator. Removal of a proportion\* of the unconverted phosphorus, by allowing the red phosphorus to separate as far as it will by sedimentation, is also recommended.

It is desirable to have the red phosphorus as stable as possible in respect of its tendency to ignite when accidentally struck or rubbed, and tendency to oxidise slowly to acidic products. Adequate heating Airing the conversion and complete elimination of white phosphorus are first essentials, but artificial stabilisation is possible. U.S.P. 2359243 (to Oldbury Electro-Chemical Co., 1944) describes an effective method which consists in suspending the red phosphorus (ground to pass 100 mesh) in a 1% solution of alkali-metalaluminate, and aerating the suspension, preferably at 80-90°C., for several hours. It is possible that the more readily oxidisable particles of red phosphorus (or localised spots of high activity on the surface of particles) begin to oxidise, become locally acid, and precipitate a protective layer of alumina. Traces of some metals of variable valency increase the liability to oxidation. Red phosphorus made in Germany was stabilised by precipitation of approximately 1% of magnesium oxide (from magnesium chloride solution and sodium hydroxide) before washing and drying. Commercial red phosphorus which has not been stabilised sometimes oxidises rapidly in warm air of high humidity.

#### V. PHOSPHORUS AS AN INDUSTRIAL HAZARD.

The following dangers arise from the use of phosphorus in industry:

(i) The Poisonous Properties of the Vapour.—Prolonged inhaling of vapours from white phosphorus (probably phosphorous oxide vapour) gives rise to\* necrosis of the jaw—the notorious "phossy-jaw," which was so well known during the nineteenth century but is practically unknown now that phosphorus sesquisulphide is used in the manufacture of matches and the use of white phosphorus for that purpose is prohibited.

(ii) The Poisonous Properties of the Solid.—Solid white phosphorus is poisonous when taken internally, and is widely used in rat and vermin poisons, which normally contain 1-4% of phosphorus.

The toxic dose depends upon the personal peculiarities of the individual and upon the physical state of the phosphorus, which governs the rate of absorption. Recovery has occurred after the taking of about 400 mg. but in general a dose of 50 mg. or above is liable to be fatal.

The symptoms are due to two causes, irritation of the gastro-intestinal tract and the slower action of the absorbed poisons. The former causes abdominal pain, nausea, vomiting, and diarrhoea, which develop during the first few hours. Thirst is intense and the breath has a garlic-like odour. If the shock of the first few hours is withstood then follow two or three days of comparative well-being before the absorbed poisons come into full action. This action causes further vomiting and diarrhoea, often nose-bleeding, headache, weakness, and enlargement

of the liver. The patient usually dies about a week after taking the poison.

Quick treatment is very desirable because of the speed with which phosphorus is absorbed through the gastro-intestinal tract. A simple treatment is to give the patient 0.25 g. of copper sulphate in a glass of water; this coats the phosphorus with copper or copper phosphide. Gastric lavage should also be performed as early as is possible, followed by Epsom salts. Subsequent treatment includes a diet high in protein and carbohydrate but low in fat, accompanied by injection of grape sugar and insulin. Large doses of ascorbic acid, thiamine, and calcium gluconate are also said to be valuable.

(iii) Spontaneous Combustion.—White phosphorus will ignite spontaneously in air unless its surface is kept wet. Phosphorus alone is a very ineffective incendiary, since its flame will not normally ignite wood and similar materials; this is to a large extent due to the production of phosphoric acid when it burns in moist air; this gives a fireproof coating on anything touched by the flame. On the other hand, a phosphorus flame will immediately ignite readily combustible materials such as petrol, paper, or celluloid.

(iv) Burns.—These are caused when phosphorus burns in contact with the skin. They heal more slowly and suppurate more easily than ordinary heat burns. The treatment is as follows:

1. Wash the burn immediately and very thoroughly with sodium carbonate solution (2 tablesp<sup>ms</sup>ful to a pint of water). This neutralises phosphoric acid, etc., formed during the burning. Whilst the burned area is still wet pick off any visible white phosphorus (often this can best be seen in the dark).
2. Wash with copper sulphate solution (1 heaped teaspoonful to a pint of water). Remove any dark-coloured deposit with forceps. The copper sulphate combines with or coats any free phosphorus and prevents further burning.
3. Wash with water containing a weak anti-septic such as boracic acid.
4. Now treat as a normal burn.

The use of ultra-violet light on the burn is beneficial. The healing period is usually about three to four weeks.

#### VI. OXIDES OF PHOSPHORUS.

Three well-defined oxides exist: phosphorus pentoxide or phosphoric anhydride,  $P_4O_{10}$ ; phosphorus trioxide, or phosphorous oxide,  $P_4O_6$ ; and an oxide intermediate between these two in state of oxidation, phosphorus tetroxide,  $(PO_2)_n$ .

Phosphorus Pentoxide.—The familiar white powder is made by burning phosphorus in a stream of dried air. Using a steady feed of molten phosphorus, a controlled excess of air, and a correctly designed burner large enough to allow adequate time for completion of reaction before the gases are cooled, phosphorus pentoxide is obtained so free from lower oxides that

it will not decolorize dilute permanganate solution even after standing for hours. The gaseous combustion products are chilled by injecting them into a large chamber, air- or water-cooled externally, where rapid mixing with cold gas causes condensation. The appearance inside such a chamber, illuminated by light from the phosphorus burner, resembles a snowstorm. This white powder consists predominantly of the most volatile of the three crystalline modifications described below. Usually it is so finely divided that its crystalline character is not visible; if the condensation is allowed to take place in a chamber maintained externally at 170-200°o. a denser and more obviously crystalline product is obtained, which, however, differs only in habit.

**Phosphorus Pentoxide Vapour.**—This consists predominantly of  $P_4O_{10}$  molecules, as appears from vapour density measurements (Victor Meyer method) by W. A. Tilden and R. E. Barnett (J.C.S. 1896, 69, 154), by C. A. West (*ibid.* 1902, 81, 928) up to 1,400°c, and by E. V. Britzke and E. Hoffmann (Monatsh. 1938, 71, 317) up to 1,100°c. Both the vapour density and the heat capacity of the vapour suggest that appreciable association occurs at least below,

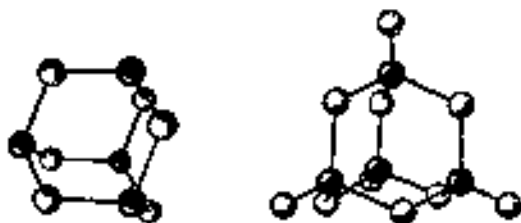

Phosphorus Trioxide.

Phosphorus Pentoxide.

FIG. 6.

1,100°o. The *heat capacity*  $C_p$  expressed per g.-mol. of  $P_4O_{10}$  is  $73.6 \pm 2.0$  g.-cal. per g.-mol. per °c, and remains constant over the range 360-1,100°c. (M. Frandsen, Bur. Stand. J. Res. 1933, 10, 35).

The structure of the isolated  $P_4O_{10}$  molecule has been worked out by G. G.-Hampson and A. J. Stosick (J. Amer. Ghem. Soc. 1938, 60, 1814). The structure consistent with their electron diffraction measurements is shown in Fig. 6, drawn from a photograph of a model in the journal referred to. The P atoms form a regular tetrahedron, each having one closely bound O atom which is not otherwise attached. Each of the remaining six O atoms is attached to two P atoms, so that the formula may be written  $(OP)_4O_6$ .

**Polymorphism of Phosphorus Pentoxide.**—The most recent studies of this problem are by W. L. Hill, G. T. Faust, and S. B. Hendricks (*ibid.* 1943, 65, 794) employing optical and X-ray methods; H. G. J. de Decker and G. H. MacGulavry (Rec. trav. chim. 1941, 60, 153) and H. C. J. de Decker (*ibid.*, p. 413) employing X-ray methods; and J. C. Southard and R. A. Nefeeon (J. Amer. Ghem. Soc. 1937, 59, 911) and A. Smits, E. P. S. Parvrf, P. G. Meerma, and H. C. J. de Decker (Z. physikal. Chem. 1940, B, 46, 43) by vapour-pressure measurements. Extensive earlier work, particularly on the

pressure-temperature relations, is referred to in these papers.

Three crystalline modifications have been studied: *hexagonal*, m.p. 420°c, the triple-point pressure being 3,600 mm. (This melting-point can be realised only by very quick heating because of the instability of the hexagonal form, which polymerises rather rapidly when heated; the liquid polymerises and quickly solidifies to a mixture of crystals of the orthorhombic form with some glass. Density, 2.3. Heat capacity,  $C_p = \{22.17 + 0.07804 \times 10^{-5} T^2\} \pm 1.6$  g.-cal. per g.-mol. of  $P_4O_{10}$  per °c. for  $25^\circ < T < 350^\circ$  (M. Frandsen, *loc. cit.*). Because of probable partial conversion of hexagonal to orthorhombic, this formula may give values slightly too high above 250°o. Vapour-pressure formula  $\log_{10} p$  (mm.) =  $10.792 - 5,000/ST$ , giving 760 mm. at  $T = 632^\circ K.$ , and a latent heat of sublimation of 22,800 g.-cal. per g.-mol. of  $P_4O_{10}$ . X-Ray diffraction established the fact that this form is a molecular lattice of individual molecules of  $P_4O_{10}$ , having the same structure as in the vapour. The crystals are soft.

Although the hexagonal form is stable indefinitely at room temperature, on heating it changes to the orthorhombic form. The change requires about two months at 180°o., but may be complete in a few hours at 250°c. The speed of the transformation is apparently very sensitive to conditions which have not yet been ascertained, and widely differing qualitative observations appear in the literature. The vapour pressure of orthorhombic phosphorus pentoxide is much smaller than that of the hexagonal form:  $\log_{10} p$  (mm.) =  $12.113 - 7,930/T$ , giving 36,400 g.-cal. per g.-mol. of  $P_4O_{10}$  for the latent heat of sublimation. The melting-point lies between 550° and 570°c.; the vapour pressure at the melting-point is about 400 mm. The fusion process is considered to be abnormally slow at this melting-point. Rapid fusion occurs at 571°c, and the suggestion is made (W. L. Hill, G. T. Faust, and S. B. Hendricks, *loc. cit.*) that both melting-points are metastable triple-points, and that the two liquid phases are structurally different. The crystal structure of orthorhombic phosphorus pentoxide shows that this modification is an infinite sheet polymer built up of  $PO_4$  tetrahedral groups, three of the O atoms being shared with neighbouring P atoms, the fourth being linked to a single P atom. The atomic spacings are close to those of the  $P_4O_{10}$  molecule. The crystals are hard and brittle, as is to be expected from the structure.

The third crystalline modification (possibly *trigonal*) is thermodynamically the most stable, at least in the temperature range from 70°o. up to its melting-point at  $580 \pm 5^\circ c$ , where the triple-point pressure is 550 mm. This stable modification is prepared by heating either of the other forms to 450°c. for 24 hours, whereby a horny mass of aggregated and twinned crystals is obtained. Its fusion is a slow process, and superheating of the crystals readily occurs; the melt is a very viscous fluid. The superheating phenomenon was reported by A. Smits and H. W. Deinum (Proc. Acad. Sci. Amsterdam, 1930, 33, 514) and by W. L. Hill, G. T. Faust,

ff&d S. B. <Hendricks (*I.e.*). The *density* calculated from the indices of refraction is 2.89. T&s is in agreement with the conclusion from directly measured (but not very concordant) values of various authors which make this the densest form. The *vapour pressure* of a high-temperature form of phosphorus pentoxide was measured by A. Smits, with H. W. Deinum (*Z. physikal. Chem.* 1930, A, 149, 337), under experimental conditions which make it likely that they were dealing with? the tetragonal modification, and with the liquid phase obtained by its fusion; the observations on the molten state extend some distance into the region of supercooling. Their data for the solid phase\* are consistent with  $\log_{10} p$  (mm.) =  $11.4664 - 7.437/T$ , from  $T = 758^\circ\text{K.}$  up to the melting-point, at  $T = 553^\circ\text{K.}$  The data for the liquid are consistent with  $\log_{10} p$  (mm.) =  $7.5492 - 4.100/T$ , where  $785 < T < 973^\circ\text{K.}$  The X-ray structure of the stable form of phosphorus pentoxide has not been worked out. The high density and the mode of cleavage suggest that it is a three-dimensional rather than a sheet polymer.

Besides appearing in the crystalline modifications, phosphorus pentoxide has a strong tendency to form glasses.

Nothing is known about the molecular weight of the  $(\text{P}_2\text{O}_6)_w$  species actually depolymerising from the polymeric crystalline modifications into the vapour. There is no reason to doubt that in all cases the vapour rapidly adjusts itself to an equilibrium in which the predominant species is  $\text{P}_4\text{O}_{10}$ .

**Chemical Properties of Phosphorus Pentoxide.**—In its most characteristic capacity, that of tin acid anhydride, phosphorus pentoxide reacts vigorously with water, forming first a mixture of partially hydrated polymeric acids and ultimately  $\text{H}_3\text{PO}_4$ . With metallic oxides or carbonates at high temperatures, salts of similar acids are formed. With alcohols and ethers analogous reactions occur, provided that the reactions are controlled by cooling to restrain the tendency of the esters to lose the elements of water with formation of olefins and phosphoric acid. The avidity with which the first stage in the hydration takes place is responsible for the common use of phosphorus pentoxide as a dehydrating reagent. A variety of ill-defined products of the partial reaction of phosphorus pentoxide with water may be encountered, depending upon whether  $\text{P}_4\text{O}_{10}$  vapour or one of the crystalline forms is hydrated, and upon the amount of water and the degree of cooling. Interesting differences in behaviour on hydration of the non-polymerised and the polymerised forms of the oxide have been mentioned from time to time, for example by W. L. Hill, G. T. Faust, and S. B. Hendricks (*I.e.*). It may be remarked that in industrial practice phosphoric acids of definite composition, corresponding to  $(\text{HPO}_3)_n$ ,  $\text{H}_n\text{P}_4\text{O}_{13}$ ,  $\text{H}_4\text{P}_a\text{O}_7$ , and  $\text{H}_3\text{PO}_4$  are all made from the oxide under conditions which are equivalent to having an excess of water vapour present at a controlled temperature and partial pressure corresponding to evaporative equilibrium for the acid required.

**Phosphorus pentoxide is comparatively readily reduced, if the temperature is high enough, by**

elements with a comparable heat of reaction with oxygen. Because of the high temperature, volatile phosphorus reaction products are usually either phosphorus itself or the oxide  $(\text{PO}_2)_n$ . With metals, usually a mixture of phosphate and phosphide is obtained.

A few special reactions are interesting. With halogens except fluorine there is no reaction, but phosphorus pentoxide heated in fluorine forms  $\text{POF}_3$  and  $\text{PF}_5$  (H. Moissan, *Bull. Soc. chim.* 1891, [iii], 5, 458). Dry hydrogen fluoride, chloride, and bromide react to some extent, producing the oxyhalides and metaphosphoric acid. The reaction  $3\text{PCl}_5 + \text{P}_2\text{O}_5 = 5\text{POCl}_3$  and the corresponding reaction with the bromide can be controlled to proceed almost quantitatively. Phosphorus pentoxide at high temperatures attacks all ceramic materials and fused silica ware.

**Phosphorus Trioxide.**—The usual method of preparation is that of T. E. Thorpe and A. E. H. Tutton (*J.C.S.* 1890, 57, 545; 1891, 59, 1019) by burning white phosphorus in a restricted stream of dry air. The products consisting of  $\text{P}_4\text{O}_6$ ,  $\text{P}_4\text{O}_{10}$ ,  $(\text{PO}_2)_n$ , and some  $\text{P}_4$ , are drawn through a glass wool filter at  $60^\circ\text{C.}$  to remove solid particles, and the volatile trioxide is condensed by cooling to below  $0^\circ\text{C.}$  Yields of over 50% are possible by correct conditions (L. Wolf and H. Schmagel, *Ber.* 1929, 62 [B], 771). The excess of phosphorus can be removed by prolonged irradiation from a mercury arc, then distilling the trioxide from the red phosphorus formed (C. C. Miller, *J.C.S.* 1929, 1823). An alternative preparation is by reaction of phosphorus trichloride and phosphorous acid, followed by vacuum distillation of the trioxide. (This is briefly referred to by F. Krafft and R. Neumann, *Ber.* 1901, 34, 566.)

**Physical Properties.**—Soft, colourless, monoclinic crystals, soluble in many organic solvents. *M.p.*  $23.8^\circ\text{C.}$ ; *b.p.*  $175.4^\circ\text{C.}$  *Vapour-pressure* formula  $\log_{10} p$  (mm.) =  $-2.860 - 0.00400T + 11.0516$  (P. M. van Doormaal and F. E. C. Scheffer, *Rec. trav. chim.* 1931, 50, 11QP). *Latent heat* at the boiling-point (calculated) 9,406 g.-cal. per g.-mol. of  $\text{P}_4\text{O}_6$ . *Vapour density* corresponds to  $\text{P}_4\text{O}_6$  (T. E. Thorpe and A. E. Tutton, *I.e.*). In solution in benzene and naphthalene the molecular weight corresponds to  $\text{P}_4\text{O}_6$ . The *molecular structure* from electron diffraction (G. C. Hampson and A. J. Gtosick, *J. Amer. Chem. Soc.* 1938, 60, 1814) is shown diagrammatically in Fig. 6. It resembles  $\text{P}_4\text{O}_6$  except for the absence of the four "phosphoryl" O atoms. *Density*,  $\rho$  of the solid, 2.135; of the supercooled liquid, 1.943. *Surface tension* 36.6 dynes per cm. at  $34.3^\circ\text{C.}$ , decreasing to 27.8 at  $109.4^\circ\text{C.}$  (R. Schenck, F. Mihr, and H. Baethien, *Ber.* 1906, 39, 1506).

**Chemical Properties.**—Phosphorus trioxide vapour is stable only up to about  $200^\circ\text{C.}$ ; the thermal decomposition produces phosphorus tetroxide and red phosphorus. (Here, as in almost every chemical reaction which occurs in a system containing oxygen, free or combined in any way, and which has red phosphorus as one of the reaction products, there is doubt whether a possible sub-oxide such as  $\text{P}_4\text{O}$  may



not also be present.) Phosphorus trioxide can be ignited and burnt in air.

Much of the early work with this oxide seems to have been done with preparations containing some white phosphorus, which is not easily removed by distillation. Some of the confusing observations on the oxidation may be explicable in this way. It has been shown by G. C. Miller (J.C.S. 1928, 1847) that phosphorus trioxide neither glows nor is oxidised in air or oxygen at ordinary temperature. In dry ozonised oxygen the overall reaction is represented by

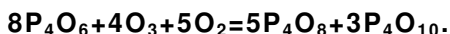

The phosphorus tetroxide (written as  $P_4O_8$ ) is not further oxidised by ozone at room temperature.

With cold water, or cold dilute alkali solutions, phosphorus trioxide behaves as the anhydride of phosphorous acid. As long as the liquid is cold, the trioxide dissolves slowly and the process is easily controlled. With hot water or concentrated alkali solutions the reaction may become violent, and phosphorus (possibly sub-oxide), hydrogen phosphides, and phosphate are also formed. An interesting reaction takes place under suitable conditions with chlorine (analogously with bromine) by which equimolecular quantities of  $POCl_3$  and (polymerised) metaphosphoryl chloride,  $(PO_nCl)_n$ , are produced. Sulphur adds on to form phosphorus sulphoxide (*q.v.*).

**Phosphorus Tetroxide.**—This little-investigated compound is a product of both thermal decomposition and oxidation of the trioxide (*q.v.*). It is separated from accompanying red phosphorus, or pentoxide, by vacuum sublimation, and appears as white crystals, probably orthorhombic. It was first analysed and characterised by T. E. Thorpe and A. E. Tutton (*ibid.* 1886, 49, 833).

Phosphorus tetroxide is very stable to heat. Vapour density, determined by C. A. West (*ibid.* 1902, 81, 923) at over  $1,400^\circ C$ , corresponded approximately to  $(PO_2)_7$ . Apparently no volatilisation occurred at  $900^\circ C$ . On the other hand, P. H. Emmett and J. F. Schultz (*Ind. Eng. Chem.* 1939, 31, 105) found, but not conclusively, a density corresponding to  $P_4O_8$  at  $500^\circ C$ .

Density,  $p_4^{2.6}$  of the crystals obtained by vacuum sublimation is 2.537 (C. A. West, *I.e.*). Melting has not been observed. No solvent has been found which does not react chemically.

**Chemical Properties.**—Heated in oxygen, phosphorus pentoxide is formed at about  $420^\circ C$ . In air, oxidation is slow at  $350^\circ C$ , rapid at  $500^\circ C$ , in the absence of a catalyst. Platinised asbestos greatly accelerates the oxidation. The crystals are deliquescent and dissolve in water with vigorous heat evolution. The solution gives the fractions of phosphorous and phosphoric acids, but it is not clear whether hypophosphoric acid is an intermediate product. The structure of phosphorus tetroxide is not known, and a review of the available evidence leaves it uncertain whether the tetroxide can be considered to be the anhydride of hypophosphoric acid.

**Other Oxides of Phosphorus.**—Two lower oxides have been repeatedly described, but proof

of the individuality of either is lacking. The case against  $P_4O_8$  has been made out by L. S. L. Chalk and J. R. Partington (J.C.S. 1927, 1980).  $P_4O_8$  is critically discussed by D. L. Chapman and F. A. Lidbury (*ibid.* 1899, 75, 973) and C. H. Burgess and D. L. Chapman (*ibid.* 1901, 79, 1243).

**Sulphoxides of Phosphorus.**—An addition product  $P_4O_6S_4$  of sulphur and phosphorus trioxide is formed quantitatively with vigorous heat evolution when the reactants are warmed to  $160^\circ C$  in an inert atmosphere (T. E. Thorpe and A. E. Tutton, *ibid.* 1891, 59, 1019). The substance sublimes in vacuum to colourless crystals, which melt at  $102^\circ C$  to a liquid of *normal* b.p.  $295^\circ C$ . The vapour density at  $350-400^\circ C$  corresponds with the formula as written above. The structure, which may be written  $(SP)_4O_6$ , has been determined by electron diffraction (A. J. Stosick, J. Amer. Chem. Soc. 1939, 61, 1130). It resembles  $P_4O_{10}$  except that the four "phosphoryl" O atoms are replaced by S atoms. The inter-atomic distances and angles are: P-O, 1.61 Å; P-S, 1.85 Å; P-P, 2.85 Å; angle O-P-O,  $101.5^\circ$ ; angle P-O-P,  $123.5^\circ$ ; angle O-P-S,  $116.5^\circ$ . Phosphorus sulphoxide crystallises in large tetragonal crystals from solution in carbon disulphide. It is deliquescent and reacts with moisture forming phosphoric acid and hydrogen sulphide.

**Phosphorus Oxysulphide,  $P_4O_4S_3$ ,** was prepared by A. Stock and K. Friederici (Ber. 1913, 46, 1380) by passing oxygen into a solution of  $P_4S_3$  in carbon disulphide, or ozonised oxygen into a solution of  $P_4S_3$  in carbon tetrachloride. It forms a pale-yellow amorphous powder, insoluble in the usual organic solvents. This oxysulphide is an extremely hygroscopic substance, which is decomposed by water. On heating it begins to fuse at about  $150^\circ C$ , and forms a yellow liquid at  $150^\circ C$ ; decomposition occurs.

**Phosphoric Oxysulphide,  $P_2O_2S_3$ ,** was discovered (A. Besson, Compt. rend. 1897, 124, 151) as a product of the reaction

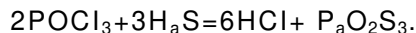

Other products, including an oxychlorosulphide,  $P_2G_2S_4$ , are formed at the same time.  $P_2O_2S_3$  is a pale-yellow amorphous solid, which melts at about  $300^\circ C$  and crystallises on cooling. Heated in vacuum, even at  $150^\circ C$ ,  $P_4S_{10}$  slowly sublimes, leaving  $P_4O_{10}$ .

## VII. OXYACIDS OF PHOSPHORUS.

The following are individuals of definite composition:

(Ortho) Phosphoric acid	$H_3PO_4$
Pyrophosphoric acid	$H_4P_2O_7$
Metaphosphoric acid	$(HPO_3)^*$
Hypophosphoric acid	$H_4P_2O_6$
(Ortho) Phosphorous acid	$H_3PO_3$
Pyrophosphorous acid	$H_4P_2O_5$
Metaphosphorous acid	$(HPO_2)^*$
Hypophosphorous acid	$H_3PO_2$

There is also a complete range of intermediate "phosphoric acids" of graded composition with H, O : P, O<sub>5</sub> ratios varying between 1:1 and 3:1,

{rbrch are considered to consist of mixtures of toplyphosphoric acids of varying degree of condensation,  $(H_2O)^x(P_2O_5)_y$ . They are produced by hydrating phosphorus pentoxide (*q.v.*) with water or steam at a moderately high temperature. A very concentrated acid is marketed in the U.S.A. under the names *Tetraphosphoric Acid*, or *Phospholeum*,  $H_6P_4O_{13}$ . It is a viscous liquid,  $p^{80}$  2.06, which does not crystallise at  $-50^\circ C$ , and is an economical material to transport for subsequent dilution.

PHOSPHORIC ACID,  $H_3PO_4$ .

The manufacture has been described in an earlier section of this article. This is the only acid containing phosphorus which is a large-scale industrial chemical.

**Physical Properties.**—Anhydrous phosphoric acid is a crystalline solid, m.p.  $42.3^\circ C$ . The only hydrate commonly encountered is  $H_3PO_4 \cdot H_2O$ , which contains 91.58% of  $H_3PO_4$ . Fig. 7 represents the equilibrium freezing-points for the concentration range of

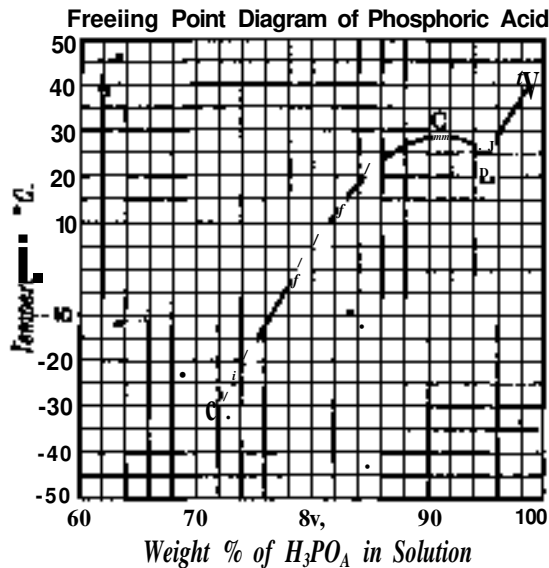

FIG. 7.

most practical interest. The equilibrium temperatures of solid  $H_3PO_4$  with solutions of different concentrations lie between the melting-point A and the eutectic B. Curve BCD represents equilibrium of the solution with the hemihydrate as the solid phase. Curve CB shows the depression of the melting-point of  $H_3PO_4 \cdot H_2O$  by addition of  $H_3PO_4$ , B (at  $23.5^\circ C$ .) being the eutectic at which  $H_3PO_4 \cdot H_2O$  and  $H_3PO_4$  co-exist as solid phases with solution, CD shows the depression of the melting-point of  $H_3PO_4 \cdot H_2O$  by addition of  $H_2O$ ; this curve continues without a break down to the eutectic point at which  $H_3PO_4 \cdot H_2O$  and ice co-exist with solution ( $-85^\circ C$ .; 62.5%  $H_3PO_4$ ). The curve as given is due to W. H. Boss and R. M. Jones (J. Amer. Chem. Soc. 1925, 47, 2105). It is to be noted that the experimental method by which it was obtained was in effect a method of investigating the equilibria of the two solids  $H_3PO_4$  and  $H_3PO_4 \cdot H_2O$  with solutions:

there is, however, good evidence that another hydrate,  $10H_3PO_4 \cdot H_2O$  may intervene in the region covered by AB (see A. Smith and A. W. C. Menzies, *ibid.* 1909, 31, 1183).

**Density and Composition.**—The values tabulated below\* are reproduced from a density composition table given in "A. and W. Chemicals," Albright and Wilson, Ltd., 1937, p. 69. The data for densities below 1.500 are based on a critical survey of the literature; those above this value were determined by Albright and Wilson, Ltd.

DENSITY OF AQUEOUS SOLUTIONS OF ORTHOPHOSPHORIC ACID.

$p^{80}$	Decrease per $1^\circ C$ .	Wt.-% $H_3PO_4$ .	Wt.-% $P_2O_5$ ?	Wt.-% P.
MOO	000030	17.52	12.69	6.54
1150	000035	25.25	18.29	7.99
1.200	000045	32.52	23.56	10.29
1.250	000050	39.22	28.41	12.41
1.300	000055	45.51	32.97	14.40
1.350	000060	51.22	37.10	16.21
1.400	000060	56.85	41.18	17.99
1.450	0.00060	62.27	45.11	19.70
1.500	000065	67.35	48.79	21.31
1.550	0.00070	72.11	52.24	22.82
1.600	000075	76.76	65.60	24.28
1.650	000075	81.30	68.89	25.72
1.700	000080	85.63	62.03	27.09
1.750	000080	89.88	65.11	28.44
1.800	0.00080	94.15	68.20	29.79
1.850	000080	98.13	71.08	31.05
1.874	0.00080	100.00	72.44	31.64

**Accuracy.**—Between 60 and 95% the uncertainty in composition for a stated density does not exceed 1 part in 400; above and below this range the uncertainty is slightly greater. The figures in the second column refer to expansion of the acid solutions in the neighbourhood of  $15^\circ C$ . Below about 50%  $H_3PO_4$  the thermal expansion increases rather rapidly between  $5^\circ$  and  $25^\circ C$ ., and the figures given are to be taken as an average for the range  $10-20^\circ C$ .

It should be noted that in England phosphoric acid is marketed in grades defined by density, commonly 1.500, 1.600, 1.650, 1.700, and 1.750. For these grades of pure acid the densities at  $60^\circ F$ . ( $p^{60}$ ) are as follows:

$p^{60}$	Decrease per $1^\circ p$ .	Wt.-% $H_3P^{(4)}$ .	Wt.-% $P_2O_5$ .	Wt.-% P.
1.500	000036	67.25	48.71	21.28
1.600	000042	76.65	55.52	24.25
1.650	000042	81.20	58.82	25.69
1.700	000044	85.53	61.96	27.06
1.750	000044	89.77	65.03	28.40

\*Solutions of phosphoric acid containing more than 72.44% of  $P_2O_5$  are generally considered to consist of equilibrium mixtures of orthophosphoric acid with pyro- and meta-acids, and probably other complex acids. The density of these more concentrated acids increases approximately linearly with the excess of  $P_2O_5$ , over 72.44%, according to the equation:

$$p^{60} = -1.874 + 0.0171(p - 72.44)$$

which holds for the range 72-44 < a % P<sub>2</sub>O<sub>5</sub> < 85 (cf. J. H. Lum, J. E. Malowan, and C. B. Durgin, Chem. Met. Eng. 1937, 44, 721).

*Viscosity.*—The values tabulated below are based on measurements by Albright and Wilson, Ltd., extended to acids stronger than 100% H<sub>3</sub>PO<sub>4</sub> by inclusion of data from J. H. Lum, J. E. Malowan, and C. B. Durgin (*I.e.*).

Viscosity IN CENTISTOKES.

Wt.-% H <sub>3</sub> PO <sub>4</sub>	69.0	75.9	82.8	89.7	96.6	—	—	—
Wt.-% P <sub>2</sub> O <sub>5</sub>	50	55	60	65	70	75	80	85
At 25°C.	8.4	12	20	37	83	260	—	—
50°C.	—	5.5	8.1	14	25	71	430	—
100°C.	—	—	2.8	4.0	6.6	15	56	590
150°C.	—	—	—	2.2	3.2	5.8	16.2	126
170°C.	—	—	—	1.9	—	4.2	—	—

*Vapour Pressures and Boiling-Points.*—Data are scanty and not very concordant. The following boiling-points at atmospheric pressure of solutions of phosphoric acid are based upon a consideration of the published vapour-pressure measurements of I. A. Kablukov and K. I. Zagvosdkin (*Z. anorg. Chem.* 1935, 224, 315), M. M. Striplin (*Ind. Eng. Chem.* 1941, 33, 910) and some boiling-point determinations by Albright and Wilson, Ltd. At concentrations close to 100% H<sub>3</sub>PO<sub>4</sub> the boiling-point is rising very steeply, and the data may possibly be in error by ±15°.

Wt.-% H <sub>3</sub> PO <sub>4</sub>	50	60	70	75	80	85
B.p., °C.	109	117	129	136	147	159
Wt.-% H <sub>3</sub> PO <sub>4</sub>	90	92	94	96	98	100
B.p., °C.	176	185	194	206	228	270

For more dilute solutions, vapour-pressure data at 100°C. are given by G. Tammann (*Landolt-Börnstein, "Physikalisch-Chemische Tabellen,"* Vol. II, 1923, p. 1389), by I. A. Kablukov and K. I. Zagvosdkin (*I.e.*) at temperatures from 25° to 80°C, and by G. S. Kasbekar (*J. Indian Chem. Soc.* 1940, 17, 657) at 25°C. Further measurements (calculated to activities) at 25°C. are given by K. L. Elmore, C. M. Mason, and J. H. Christensen (*J. Amer. Chem. Soc.* 1946, 68, 2528) for the range 0-75 mol.-% H<sub>3</sub>PO<sub>4</sub>. It appears that Kablukov and Zagvosdkin's values at this temperature are somewhat too high for concentrations higher than 25 mol.-% H<sub>3</sub>PO<sub>4</sub>. A nomograph for the range 25-40°C. and 77-94% H<sub>3</sub>PO<sub>4</sub> is given by J. H. Perry and H. C. Duijs (*Chem. Met. Eng.* 1934, 41, 74).

*Specific Heat.*—Specific heats of phosphoric acid solutions at 21-3°C., and the mean specific heats over certain useful temperature ranges, have been determined by M. M. Popoff, S. M. Skuratoff, and N. N. Feodosjeff (*Z. physikal. Chem.* 1933, A, 167, 42). The values at 21-3°C. are consistent with the formula:

$$\text{Sp.-heat (21-3°C.)} = 1000 - (7.54 \times 10^{-2})x - (4.3 \times 10^{-6}) * H(1.827 \times 10^{-7})x^2$$

for 0 < x % H<sub>3</sub>PO<sub>4</sub> < 90. This formula is probably correct to within one part in fifty. An

independent measurement at n=160 gave 0.3ff The data for the mean specific heat between 20°C. and 100°C. are consistent with the formula:

$$\text{Sp. heat (20-100°C.)} = 1.0109 - 0.00709n,$$

for 0 < x % H<sub>3</sub>PO<sub>4</sub> < 60. The values obtained from this formula are probably accurate to within one part in fifty. For acids of concentrations higher than 60% the mean specific heats are given by these authors for the temperature ranges from about 20°C. to temperatures close to the boiling-points of the solutions. The data are tabulated below (rounded figures).

% H <sub>3</sub> PO <sub>4</sub>	Temperature range, °C.	Mean specific heat.
65	20-118	0.59
70	20-120	0.57
75	20-130	0.54
80	20-140	0.52
85	21-150	0.49
90	22-150	0.48

*Heat Transfer, Film Coefficient.*—H. E. Zinn, H. G. Thoeming, and C. G. Duncan-Clark (*Trans. Amer. Inst. Chem. Eng.* 1941, 37, 399) determined the film coefficients, *h*, B.Th.U. per hr. per sq. ft. per °F., for heat transfer from phosphoric acid to impregnated graphito (Karbate). Their data for acids of three concentrations can be summarised by the equation log<sub>10</sub> *h* = *A* log<sub>10</sub> *R<sub>e</sub>* - *B*, where *R<sub>e</sub>* is the Reynolds number, and *A* and *B* are constants which have the following values:

Wt.-% H <sub>3</sub> PO <sub>4</sub>	<i>A</i>	<i>B</i>	Temperature range, °C.
55	0.73	0.24	30-80
80	0.84	0.62	30-80
90	0.98	1.07	40-80

*Latent Heats of Fusion.*—From the measurements of heats of solution by J. Thomsen and A. Joly (*J. Thomsen, "Thermochemische Untersuchungen,"* Leipzig, 1882-86) the following values for the heats of fusion are derived:

	Kg.-cal. per g. formula weight.	G.-cal per g.
H <sub>3</sub> PO <sub>4</sub>	2.52	25.7
H <sub>3</sub> PO <sub>4</sub> .JH <sub>2</sub> O	3.64	340

*Heats of Dilution.*—The data tabulated below are based mainly upon the measurements of J. Thomsen and A. Joly (*J. Thomsen, op. cit.*). The first column gives the percentage by weight of H<sub>3</sub>P.O<sub>4</sub> in the liquid before dilution. The second column gives the density *p*<sup>5</sup> of the liquid. The third column gives the heat evolved (per g. of H<sub>3</sub>PO<sub>4</sub> contained in the solution) on diluting

the acid to a very low concentration (i.e., the limiting heat for "infinite dilution"). The last column gives the corresponding heat evolution per litre of solution taken for dilution. The heat evolved on dilution from one concentration to another is obtained by combination of the appropriate heat values in the third column. The heat values apply strictly to dilution at 19°C.

% H <sub>3</sub> PO <sub>4</sub> .	G., cal per g. H <sub>3</sub> PO <sub>4</sub> .	Kg.-cal per litre solution.
10000	54.6	1021
8500	45.3	73.4
7000	43.2	68.2
6000	38.0	55.3
5000	32.6	42.7
4000	25.4*	27.2
3000	23.7	23.9
2000	19.8	17.0
1000	14.9	10.0
500	10.3	5.2
200	5.2	1.2
100	3.0	0.3

*Dissociation Constants.*—The thermodynamic constants\* for the dissociation of H<sub>3</sub>PO<sub>4</sub> are expressed by:

$$pK_1 = 2.0304 + (5 \times 10^{-5})(t + 18)^2$$

for 0 < t < 60, with a probable error of less than 1% (L. F. Nims, J. Amer. Chem. Soc. 1934,

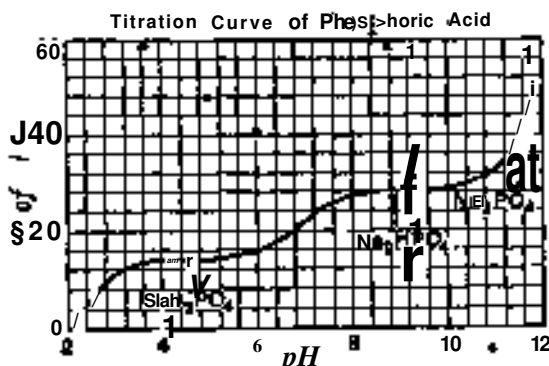

FIG. 8.

56, 1110). This gives  $K_1 = 7.54 \times 10^{-3}$  at 25°C. The thermodynamic constants for the dissociation of H<sub>3</sub>PO<sub>4</sub> are expressed by:

$$pK_2 = 2.0730 - 0.0005(T - 5) + 0.000012T^2$$

where  $K_2 = 7.54 \times 10^{-3}$ , and 0 < t < 50 (R. G. Bates and S. F. Acree, J. Res. Nat. Bur. Stand. 1945, 84, 373), whence at 25°C.  $pK_2 = 7.1993$ , or  $K_2 = 6.32 \times 10^{-8}$ . Within the stated temperature range the equation reproduces the measurements with a maximum departure of 0.0023. At 55° and 60°C, the experimental values of  $pK_2$  are respectively 7.1870 and 7.1944. Other, somewhat less recent, data for  $pK_2$  and  $pH_2$  are in agreement.

The third dissociation constant is only approximately known;  $pK_3$  is between 12 and 13, so

that trisodium phosphate is considerably hydrolysed in solution.

*Titration Curve of Orthophosphoric Acid.*—The fact that  $K_1$ ,  $K_2$ , and  $K_3$  are of quite different orders of magnitude makes the titration curve of considerable interest. When sodium hydroxide solution is added to a solution of phosphoric acid, neutralisation to NaH<sub>2</sub>PO<sub>4</sub>, Na<sub>2</sub>HPO<sub>4</sub>, and Na<sub>3</sub>PO<sub>4</sub> occurs in three separate stages. Fig. 8 shows the variation in pH during the addition of NaOH solution (0.0919 N.) to 100 c.c. of H<sub>3</sub>PO<sub>4</sub> solution (0.01277 M.) at 20°C. (data from H. T. S. Britton, J.C.S. 1927, 614).

PYROPHOSPHORIC ACID, H<sub>4</sub>P<sub>2</sub>O<sub>7</sub>.

*Preparation.*—Aqueous solutions of the free acid are readily prepared by passing hydrogen sulphide through suspensions of lead or copper pyrophosphate and concentrating the filtered solutions by freezing or vacuum evaporation. Hydrolysis to orthophosphate is slow at room temperature, but rapid at 100°C. The usual method of manufacture of pyrophosphoric acid is from orthophosphoric acid, either by heating to remove water (at about 250°C.) or, preferably, by adding phosphorus pentoxide and heating and stirring. By either method, when the composition has been adjusted to H<sub>4</sub>P<sub>2</sub>O<sub>7</sub> a viscous liquid is obtained which usually remains liquid at room temperature for a long time; eventually solidification occurs.

*Properties.*—The melting-point of the anhydrous acid is about 61°C. A hydrate, H<sub>4</sub>P<sub>2</sub>O<sub>7</sub> · 1/2 H<sub>2</sub>O, m.p. 26°C, has been reported (H. Giran, Compt. rend. 1908, 146, 1270). The density of the liquid of empirical composition H<sub>4</sub>P<sub>2</sub>O<sub>7</sub> is expressed by  $d = 1.992 - 0.000683(t - 20)$ , for temperatures t° (J. H. Lum, J. E. Malowan, and G. B. Djirgin, Chem. Met. Eng. 1937, 44, 721). For strong acids of a range of composition including H<sub>4</sub>P<sub>2</sub>O<sub>7</sub>,  $pK_1$  is given under the heading Phosphoric Acid.

*Viscosity.*—The liquid acid is included in the table of viscosities given under Phosphoric Acid. H<sub>4</sub>P<sub>2</sub>O<sub>7</sub> contains 79.76% of P<sub>2</sub>O<sub>5</sub>.

When solid anhydrous pyrophosphoric acid is carefully dissolved in water, hydrolysis through temperature rise being avoided, analysis (see A. B. Gerber and F. T. Miles, Ind. Eng. Chem. [Anal.], 1938, 10, 519) shows that the solution remains essentially pyrophosphoric acid. If, however, the acid is first heated above its melting-point, and the liquid cooled to room temperature and dissolved, a substantial proportion of the acid is found in the form of a mixture of meta- and ortho-phosphoric acids. It should be noted that pyrophosphoric acid is not used as a starting point for the large-scale manufacture of pyrophosphates.

*Dissociation Constants.*—The four dissociation constants are known with only moderate accuracy: at 18°C.,  $pK_1 = 0.85$ ,  $pK_2 = 1.96$ ,  $pK_3 = 6.68$ ,  $pK_4 = 9.39$ ; the first two values are those of G. A. Abbott and W. C. Bray (J. Amer. Chem. Soc. 1909, 31, 729) and the last two of I. M. Kolthoff and W. Bosch (Rec. trav. chim. 1928, 47, 819).

METAPHOSPHORIC ACID, (HPO<sub>3</sub>)<sub>n</sub>.

When phosphorus pentoxide reacts with the correct amount of water, and the product is heated until it becomes physically homogeneous (in practice this means obtaining a liquid at 350° or over) and then cooled, metaphosphoric acid is obtained with physical properties which depend upon the temperature and duration of heating and the rate of cooling. It is more usual to start with orthophosphoric acid and dehydrate it by strong heating. Metaphosphoric acid has been obtained in various stages of polymerisation, but much of the work reported is in need of repetition with attention to purity; the extremely corrosive nature of hot metaphosphoric acid requires special consideration. Reference may be made to the work of P. Pascal and Mme. Réchid (*Compt. rend.* 1933, 196, 828); Mme. Réchid (*ibid.*, 1933, 196, 860); A. Travers and Y. K. Chu (*ibid.* 1934, 198, 2100), where the preparation and some properties of dimetaphosphoric acid, H<sub>2</sub>P<sub>2</sub>O<sub>6</sub>, are described. All varieties of metaphosphoric acid vaporise when heated to 1,000° c. According to W. A. Tilden and R. E. Barnett (*J.C.S.* 1896, 69, 154) the vapour density, by the Victor Meyer method in platinum apparatus, is compatible with the dimeric formula H<sub>2</sub>P<sub>2</sub>O<sub>6</sub>; however, there are indications of decomposition with loss of water, and this interpretation of the vapour density is uncertain.

As marketed commercially, metaphosphoric acid (or glacial phosphoric acid) appears as a sticky solid. For some purposes this is hardened by inclusion of a considerable proportion of sodium metaphosphate, to make it easier to handle. The highly polymerised forms of metaphosphoric acid (glasses) all possess the property of coagulating albumen, and in general of reacting with proteins. The acid strength of metaphosphoric acid is somewhat greater than that of H<sub>3</sub>PO<sub>4</sub>.

HYPOPHOSPHORIC ACID, H<sub>4</sub>P<sub>2</sub>O<sub>6</sub>.

**Preparation.**—When white phosphorus partially immersed in water is allowed to oxidise in air, a mixture of hypophosphoric, phosphorous, and phosphoric acids is formed. Addition of sodium acetate precipitates the slightly soluble salt Na<sub>2</sub>H<sub>2</sub>P<sub>2</sub>O<sub>6</sub>·6H<sub>2</sub>O. Anodic oxidation of copper phosphide yields up to 60% of the dissolved phosphorus as hypophosphate (A. Rosenheim and J. Pinsker, *Ber.* 1910, 43, 2003). This has been confirmed by S. C. Frowde (University of London Thesis, 1938, "The Preparation and Anodic Oxidation of Metallic Phosphides"). Oxidation of red phosphorus by cold sodium hypochlorite solutions gives a 25% yield of hypophosphate (J. Probst, *Z. anorg. Chem.* 1929, 179, 155).

• **Structure.**—There is no reasonable doubt that the double formula H<sub>4</sub>P<sub>2</sub>O<sub>6</sub> is correct. None of the properties of the acid or its salts is definitely inconsistent with the double formula, whereas the freezing-point lowering, allowing for dissociation and the ionic field effect (P. Nylón and O. Stelling, *ibid.* 1933, 212, 169), the Raman spectrum (J. Gupta and A. K. Majumdar, *J. Indian Chem. Soc.* 1942, 19, 286), and decisively

the diamagnetism of hypophosphates in general (F. Bell and S. Sugden, *J.C.S.* 1933, 48) are compatible with the simple formula; H<sub>2</sub>P<sub>2</sub>O<sub>6</sub> and its salts would contain an odd number of electrons, and would therefore be paramagnetic. As between the unsymmetrical structure (HO)<sub>2</sub>(PO)O(PO)OH and the symmetrical structure (HO)<sub>2</sub>(OP)-(PO)(OH)<sub>2</sub>, (or their corresponding 4-co-ordinated forms,



the symmetrical is the more likely. It explains the tetrabasicity of hypophosphoric acid, and the position and singleness of the X-ray absorption edge associated with the P atom; the only evidence favouring the unsymmetrical structure is the fact that sodium hypophosphate can be oxidised to sodium pyrophosphate by bromine water, suggesting the existence of the P-O-P linkage (B. Buser and P. Halpern, *Z. anorg. Chem.* 1933, 215, 33). However, a consideration of the comparative structures of the P<sub>4</sub> molecule and the P<sub>4</sub>O<sub>6</sub> molecule, which is formed at low temperatures from P<sub>4</sub>, weakens this argument. It is also interesting that the methods by which hypophosphoric acid has been obtained either involve oxidation of elemental phosphorus, or hydrolysis and oxidation of P<sub>2</sub>I<sub>4</sub> (J. H. Koltowska, *ibid.* 1937, 230, 310), or oxidation of phosphorous acid by iodine, and in all of these the formation of a P-P bond seems readily intelligible.

Hypophosphoric acid slowly hydrolyses in aqueous solution (much more rapidly in the presence of added strong acids, or when heated) to orthophosphoric and phosphorous acids. Alkalis do not accelerate the hydrolysis; at first sight this is unexpected in view of the P-P bond, but the strong repulsion of the OH<sup>-</sup> ion by the quadruple charge of the hypophosphate anion may be the explanation.

**Properties.**—Hypophosphoric acid forms a hydrate H<sub>4</sub>P<sub>2</sub>O<sub>6</sub>·2H<sub>2</sub>O, m.p. 62° c. This slowly loses water in a desiccator, partial liquefaction occurs, and the anhydrous acid separates, m.p. 55° c. (A. Joly, *Compt. rend.* 1886, 102, 110). The hydrated acid is stable in the solid state, but decomposes rapidly and exothermally just above its melting-point into phosphorous and phosphoric acids. It is a very soluble substance.

The four dissociation constants are approximately:  $\nu K_1 = 2 \times 10^{-2}$ ;  $\nu K_2 = 2 \times 10^{-3}$ ;  $\nu K_3 = 7 \times 10^{-4}$ ;  $\nu K_4 = 10^{-10}$ . All four series of sodium and ammonium salts are known, and also some salts that are more acid. The silver and thorium salts, Ag<sub>4</sub>P<sub>2</sub>O<sub>6</sub> and ThP<sub>2</sub>O<sub>6</sub>, are very insoluble and have been used in analysis. Many hypophosphates are sparingly soluble. They decompose when strongly heated, much in the same way as phosphites.

PHOSPHOROUS ACID, H<sub>3</sub>PO<sub>3</sub>.

Two methods of preparation are used for commercial purposes. Phosphorus trichloride can be hydrolysed by water (it is best to use a concentrated solution of hydrochloric acid as the source of water, and to cool during the reaction). Evaporation up to but not exceeding 180° c. gives a good yield of the crystalline acid. Alternatively, white phosphorus can be boiled with

'Strong caustic soda solution, whereby phosphine, hydrogen, and sodium phosphite are produced, but not hypophosphite, and the free acid obtained via the rather insoluble barium salt. A variant of this is the use of by-product calcium phosphite obtained in the manufacture of calcium hypophosphite.

Properties.—Phosphorous acid is a very hygroscopic crystalline solid, m.p.  $\approx 73^\circ\text{C}$ . It is extremely soluble in water? It is a dibasic acid, forming two series of salts corresponding to  $M_2\text{HPO}_3$  and  $M\text{H}_2\text{PO}_3$ , and in addition some still more acid salts. In general, metallic phosphites, particularly the acid salts, are readily soluble, although  $\text{CaHPO}_3 \cdot \text{H}_2\text{O}$  and  $\text{BaHPO}_3 \cdot \text{H}_2\text{O}$  are exceptions. The free acid and all the salts decompose to phosphate, phosphine, and water vapour on heating to temperatures above about  $200^\circ\text{C}$ . Dehydration of  $\text{NaH}_2\text{PO}_3$  well below this temperature gives the pyrophosphite  $\text{Na}_2\text{H}_2\text{P}_2\text{O}_5$ , which in aqueous solution hydrolyses at the boiling-point to phosphite.

Phosphorous acid and the phosphites are strong reducing agents, but as with hypophosphites, the action is often unexpectedly slow. Boiling with caustic alkalis does not liberate hydrogen. The kinetics of oxidation by halogens have been extensively studied (A. D. Mitchell, J.C.S. 1923, 123, 2241; A. Berthoud and W. E. Berger, J. Chim. phys. 1928, 25, 568; B. O. Griffith and A. McKeown, Trans. Faraday Soc. 1933, 29, 611).

It is generally considered that phosphorous acid has the 4-co-ordinated structure  $[\text{O}_3\text{PH}]\text{H}_2$ , or at least that this is the best simple representation for the structure of the inorganic phosphites. The first "dissociation constant of phosphorous acid,  $pK_1$  corresponds to a very much stronger acid than would be anticipated for the structure  $\text{P}(\text{OH})_3$ ." The point is discussed by G. E. K. Branch and M. Calvin ("The Theory of Organic Chemistry," Prentice-Hall, Inc., New York, 1941) who point out that a tauto-

merism  $\text{P}(\text{OH})_3 \rightleftharpoons \text{HPO}(\text{OH})_2$ , with dissociation of protons from the O atoms, goes some way towards accounting for the discrepancy, but does not explain why phosphorous acid is even stronger than phosphoric, and also\* that it is not clear why  $\text{P}(\text{OH})_3$  should not be the stable structure. (Dissociation of a proton from the P atom leaves the same anion as would be given by  $\text{P}(\text{OH})_3$ , and, as these authors point out, the dissociation constant would then be less than that expected for the structure  $\text{P}(\text{OH})_3$ .) Branch and Calvin discuss the possible resonance structures which may be involved (and which are not possible with  $[\text{PO}_4]\text{H}_3$ ) and conclude that the apparently anomalous acid strength is to be explained by these structures.

#### PYROPHOSPHOROUS ACID.

This dibasic acid was prepared by V. Auger (Compt. rend. 1903, 136, 814) by shaking together orthophosphorous acid and excess of phosphorus trichloride:

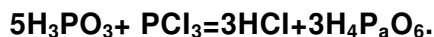

The reaction takes place over several hours at  $30-40^\circ\text{C}$ ., and is completed by standing in a desiccator with caustic potash for some days. Pyrophosphorous acid forms needle crystals which melt at  $38^\circ\text{C}$ .; the liquid decomposes at about  $100^\circ\text{C}$ . Water hydrolyses it instantly to phosphorous acid.

#### METAPHOSPHOROUS ACID, $(\text{HPO}_2)_n$ .

Oxidation of phosphine by oxygen produces phosphoric acid, or phosphorous acid, or a compound  $\text{HPO}_2$ , according to the conditions of reaction. The last named is produced by the reaction  $\text{PH}_3 + \text{O}_2 = \text{H}_2 + \text{HPO}_2$ , which takes place at room temperature when phosphine and oxygen, both initially at or below 25-5 mm. pressure, are allowed to mix slowly by diffusion. Feathery white crystals, melting-point higher than  $80^\circ\text{C}$ ., are formed on the walls of the reaction vessel. Nothing else is known about this compound except that it reacts with water forming phosphorous acid, and hence it was considered by its discoverer, H. J. van de Stadt (Z. physikal. Chem. 1893, 12, 322) to be metaphosphorous acid.

#### HYPOPHOSPHOROUS ACID, $\text{H}_3\text{PO}_2$ .

Properties.—The pure acid forms colourless deliquescent crystals, m.p.  $26.5^\circ\text{C}$ ., which decompose above  $130^\circ\text{C}$ . into phosphoric and phosphorous acids and hydrogen and phosphine. Structurally the substance is written  $\text{OPH}_2\text{OH}$ , which is confirmed by the Raman frequencies (A. Simon and F. Fehér, Z. anorg. Chem. 1937, 230, 289) and by X-ray analysis of the ammonium salt (W. H. Zachariasen and R. C. L. Mooney, J. Chem. Physics, 1934, 2, 34). Hypophosphorous acid is a monobasic acid, with  $pK_1$  about the same as  $pK_1$  for  $\text{H}_3\text{PO}_4$ . As with phosphorous acid (*q.v.*), hypophosphorous acid is considered to be too strong to be  $\text{HP}(\text{OH})_2$ , and it is concluded that the anomalous strength is a consequence of resonance.

Almost all metallic hypophosphites are readily soluble in water. In aqueous solution the acid and its salts are strong reducing agents, although the rate of reaction is often surprisingly small. The kinetics of oxidation of hypophosphorous acid in aqueous solution by the halogens (A. D. Mitchell, J.C.S. 1920, 117, 1322; R. O. Griffith and A. McKeown, Trans. Faraday Soc. 1934, 30, 530) and by cupric and mercuric chlorides (A. D. Mitchell, J.C.S. 1922, 121, 1624) have been intensively studied.

Manufacture.—Free hypophosphorous acid as a commercial commodity is in small demand. It is usually marketed in the form of a 30% solution. It is made from the calcium or barium salt by precipitation with sulphuric acid. Hypophosphites, on the other hand, have for many years been used in pharmaceutical preparations. The manufacture is always based upon direct reaction of white phosphorus with alkaline solutions, usually a boiling slurry of lime. The products of the reaction are calcium hypophosphite (in solution), calcium phosphite (insoluble), phosphine (containing sufficient  $\text{P}_2\text{H}_4$  to make it spontaneously inflammable) and hydrogen. The mechanism of this complicated

reaction is not understood. The action is often represented by two equations:



The first of these equations requires that one-fourth of the reacting phosphorus shall appear as phosphine, and the second requires that the volume of hydrogen formed shall be proportional to the amount of phosphite\*. However, in a study of the process by Albright and Wilson, Ltd., it has been shown that neither requirement is fulfilled, and practical results are much more nearly consistent with:

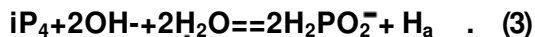

In agreement with these equations, the data show that equal amounts of phosphorus appear as phosphine and as phosphite, and the volume of hydrogen liberated is more nearly proportional to the hypophosphite formed than to the phosphite. These generalisations applied to both calcium and sodium hydroxides as sources of OH<sup>-</sup>. A certain amount of decomposition of hypophosphite by alkali must also occur through reaction (2), but it seems to be of subsidiary importance, especially when lime is used. The kinetics of reaction (2) have been studied by A. Sieverts and F. Loessner (*Z. anorg. Chem.* 1912, 76, 10) and it appears that the rate-controlling step is first-order with respect to the ion H<sub>2</sub>PO<sub>2</sub><sup>-</sup> and second order with respect to OH<sup>-</sup>.

#### PBBACID3 OF PHOSPHOBUS.

There is indirect evidence that two peracids exist, permonophosphoric acid, H<sub>3</sub>PO<sub>5</sub>, and peridiphosphoric acid, H<sub>4</sub>P<sub>2</sub>O<sub>8</sub>. Neither has been obtained as the free acid in a pure state. A number of phosphates and pyrophosphates containing co-ordinated hydrogen peroxide have been prepared, and these, as S. Husain and J. R. Partington emphasise (*Trans. Faraday Soc.* 1928, 24, 235), have sometimes been confused with true perphosphates. A list of such compounds will be found in the reference given. It does not appear that either the peracids or the hydrogen peroxide compounds have been found useful in industry.

Permonophosphoric acid was prepared by J. Schindlin and P. Massini (*Ber.* 1910, 43, 1162) by acting upon phosphorus pentoxide with very concentrated hydrogen peroxide (96.3% H<sub>2</sub>O<sub>2</sub>). Using acetonitrile as an inert solvent for the hydrogen peroxide, G. Toennies (*J. Amer. Chem. Soc.* 1937, 59, 555) obtained comparatively stable solutions of the peracid in 65% yield:

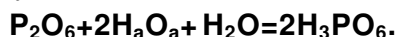

Attempts to crystallise solid salts of this acid led to decomposition.

Solutions of peridiphosphoric acid have been prepared by electrolysis of potassium or ammonium dihydrogen phosphate in the presence of fluoride (Fr. Fichter and E. Gutzwiller, *Helv. Chim. Acta*, 1928, 11, 323). Another method of preparation is by the action of hydrogen per-

oxide upon pyrophosphoric acid. The solution of the acid is rather more stable and less reactive than permonophosphoric acid; in particular it reacts more slowly with iodide, and an analytical distinction between the two is based upon this fact. Some peridiphosphates are stable in the solid state. A high concentration of hydron hydrolyses peridiphosphoric acid to permonophosphoric acid.

#### VIII. PYROPHOSPHATES, METAPHOSPHATES, AND POLYPHOSPHATES OF SODIUM.

Metaphosphoric acid was first reported by J. J. Berzelius in 1816, and the tetrafluoride salt of pyrophosphoric acid by L. Clark in 1827. Systematic study of the salts of condensed and polymerised phosphoric acids began with the recognition by T. Graham (*Rtil. Trans.* 1833, 123, 253) of the constitutional relationship of ortho- to pyro-, and meta-phosphates, and the distinction between different forms of sodium metaphosphate. A voluminous literature on this section of inorganic chemistry now exists; unfortunately some of the earlier work did not take advantage of physical principles which were understood at the time, and numerous contradictions are superimposed on a chaos of nomenclature. Historical reviews of the early development have been presented by F. Warschauer (*Z. anorg. Chem.* 1903, 36, 137) and K. Karbe and G. Jander (*Kolloid-Beih.* 1942, 54, 1).

The information presented here is confined to the sodium salts, and further restricted to those which are well-defined or which have industrial importance. Parenthetically it may be observed that in recent years (1935-) there has been remarkable growth in the consumption of several phosphates of sodium. Di- and tri-sodium orthophosphates and tetrasodium pyrophosphate are widely used in the treatment of water for industrial purposes, and as detergents and in the manufacture of soap preparations. Sodium tripolyphosphate has recently been included among the phosphates used in controlling hardness of water, and its use is likely to expand. Sodium metaphosphates and the soluble glasses intermediate between NaPO<sub>3</sub> and Na<sub>5</sub>P<sub>3</sub>O<sub>10</sub> have become versatile industrial chemicals through their power of forming stable soluble complexes with bivalent and trivalent cations, and because of the possession of remarkable surface-active properties. Acid sodium pyrophosphate Na<sub>2</sub>H<sub>2</sub>P<sub>2</sub>O<sub>7</sub> is one of the more important acidic constituents now used for aeration in baking.

Sodium Pyrophosphates.—The hydrogen atoms of H<sub>4</sub>P<sub>2</sub>O<sub>7</sub> can be successively replaced by sodium. NaH<sub>3</sub>P<sub>2</sub>O<sub>7</sub> is a very deliquescent substance prepared by mixing pyrophosphoric acid and acid sodium pyrophosphate, but has not been studied to any extent. Na<sub>3</sub>H<sub>2</sub>P<sub>2</sub>O<sub>7</sub> is prepared by dissolving Na<sub>2</sub>H<sub>2</sub>P<sub>2</sub>O<sub>7</sub> and Na<sub>4</sub>P<sub>2</sub>O<sub>7</sub> and crystallising the solution. Below 29°C. Na<sub>3</sub>HP<sub>2</sub>O<sub>7</sub>·9H<sub>2</sub>O separates; this is an efflorescent substance which loses water vapour to form Na<sub>3</sub>HP<sub>2</sub>O<sub>7</sub>·H<sub>2</sub>O. Intermediate hydrates, which have been reported, appear to be



mixtures of these two. Neither salt has found practical application.

**Isid Sodium Pyrophosphate**,  $\text{Na}_2\text{H}_2\text{P}_2\text{O}_7$ , forms large crystals of an efflorescent hexahydrate. The transition temperature at which hexahydrate, anhydrous salt, and saturated solution co-exist is  $27^\circ$ . The solubility is 16.5 g. of  $\text{Na}_2\text{H}_2\text{P}_2\text{O}_7$  per 100 g. of  $\text{H}_2\text{O}$  at  $25^\circ\text{C}$ .

The anhydrous salt, in a finely ground condition, is the form used in baking powder. Many thousands of tons are used annually for this purpose in England alone. It is manufactured by dehydrating monosodium orthophosphate with careful control of temperature and time of heating. The process control in practice tends to be closer than would be inferred from the temperatures at which 1 atm. pressure of water vapour is reversibly established in the systems:

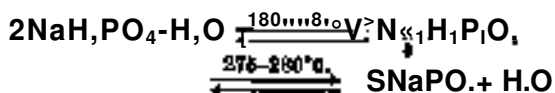

It is possible to manufacture acid sodium pyrophosphate containing consistently less than 1% of orthophosphate and less than 1% of metaphosphate. Several types of equipment are in use for the conversion process; batch ovens with the orthophosphate on trays, operated according to a time-temperature cycle; rotating drums in which orthophosphate batches are heated by internal or external firing; or continuous internally gas-fired rotary driers.

**Tetra Sodium Pyrophosphate** forms a well-defined hydrate  $\text{Na}_4\text{P}_2\text{O}_7 \cdot 10\text{H}_2\text{O}$  by crystallisation between the transition temperature ( $79.5^\circ$ ) according to the solubility data of H. Menzel and L. Sieg, *Z. Elektrochem.* 1932, 38, 283), at which the anhydrous salt is the second solid phase. The solubility according to these authors is:

Temp. $^\circ\text{C}$	0	200	400	600	79.5	1000
G. of $\text{Na}_4\text{P}_2\text{O}_7$ in 100 g. of $\text{H}_2\text{O}$	2.2	5.5	10.9	24.6	57.5	43.5

The anhydrous salt is usually manufactured by heating disodium orthophosphate in ovens or rotary kilns to a temperature of  $400-500^\circ$ . No special control is required, the salt being thermally stable, and melting at  $985^\circ$ .

In aqueous solution at  $100^\circ\text{C}$ , hydrolysis of pyrophosphate to orthophosphate is rapid in the presence of hydriion and extremely slow at pH values between 9 and 13. Concentrated caustic alkalis, however, hydrolyse it readily.

**Sodium Trimetaphosphate**.—The anhydrous salt is made by heating  $\text{NaH}_2\text{PO}_4$  or  $\text{Na}_2\text{H}_2\text{P}_2\text{O}_7$  to  $500-600^\circ\text{C}$ . All other forms of sodium metaphosphate (*Maddrell salt*, *Kurrol salt*, sodium metaphosphate glass) are converted into trimetaphosphate in this temperature range. It is a colourless substance, m.p.  $628^\circ$ , which crystallises well from molten  $\text{NaPO}_3$ , and is readily soluble in cold and hot water. Two hydrates are known,  $\text{Na}_3(\text{PO}_3)_3 \cdot 6\text{H}_2\text{O}$ , obtained by recrystallisation from water, and  $\text{Na}_3(\text{PO}_3)_3 \cdot \text{H}_2\text{O}$  obtained by precipitation from a hot solution with alcohol. At moderate concentrations  $\text{Na}_3(\text{PO}_3)_3$  does

not form precipitates with  $\text{Ag}^+$ ,  $\text{Pb}^{++}$ ,  $\text{Ca}^{++}$  or  $\text{Ba}^{++}$ . Almost all trimetaphosphates are at least moderately soluble. Stable complex ions are not formed, and the substance has found no useful application except as an intermediate in the manufacture of hydrated sodium tripolyphosphate (*q.v.*).

It is probable that the structure of the trimetaphosphate ion will prove to contain a symmetrical six-membered ring with alternate P and O atoms. If so, it is the anion of an acid in which the three acid functions are so strong that they titrate together. Freezing-point depression in water indicates a trimeric formula (P. Nyten, *Z. anorg. Chem.* 1936, 229, 30). Conductance measurements also support this formula (A. Wiesler, *ibid.* 1901, 28, 177). Further evidence is provided by the production of sodium tripolyphosphate on hydrolysis by caustic soda:

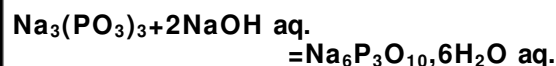

The tripolyphosphate is comparatively stable in alkaline solution, and this hydrolysis of trimetaphosphate is the basis of one of the industrial methods of manufacturing hydrated sodium tripolyphosphate (U.S.P. 2365190, 1944, to G. B. Hatch; G.P. 734511, 1943, to W. Faber). If the hydrolysis is catalysed by hydriion instead of hydroxyl ion, further hydrolysis to orthophosphate plus pyrophosphate readily occurs; the reaction can be arrested at the tripolyphosphate stage by using as the acid hydrolytic reagent acetic acid and zinc acetate, whereby a crystalline precipitate of hydrated zinc sodium tripolyphosphate is produced:

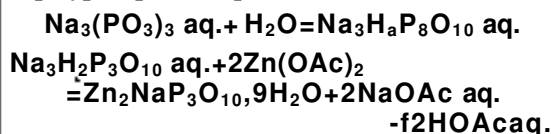

This hydrated zinc sodium tripolyphosphate was frequently encountered by investigators of trimetaphosphate, but often mistaken for other compounds.

**Sodium Tetrametaphosphate**.—F. Warschauer (*Z. anorg. Chem.* 1903, 36, 137) made this salt by treating copper oxide with excess of orthophosphoric acid at a temperature not exceeding  $400^\circ\text{C}$ . From the resulting copper metaphosphate the sodium salt was obtained by treatment with sodium sulphide solution. Crystallisation gave needle-like crystals of a tetrahydrate  $\text{Na}_4(\text{PO}_3)_4 \cdot 4\text{H}_2\text{O}$ . A decahydrate also exists, which decomposes to the tetrahydrate on exposure to air or in the saturated solution at room temperature. The cold saturated solution contains about 10% of  $\text{NaPO}_3$ . Conductance measurements by F. Warschauer (*l.c.*), measurements of freezing-point lowering by P. Nyl6n (*ibid.* 1936, 229, 30), the work of A. Boultt (*Ann. Chim.* 1942, [xi], 17, 213) on conductance and freezing-point lowering, and of P. Bonneman-Bemia (*ibid.* 1941, [xi], 16, 395) on freezing-point lowering, all support the tetrameric formula. Claims that this salt is reversibly convertible at high temperatures into trimetaphosphate have not been substantiated. It is

possible that the structure of the anion contains an eight-membered ring with alternate P and O atoms. A cyclic structure would be consistent with its resemblance to sodium trimetaphosphate in possessing a well-defined crystalline character, absence of the weak acid character associated with terminal groups of structure  $-(\text{PO}_4)^{3-}$  (v. *infra*) and small power of complex-ion formation (v. *infra*).

*Sodium Metaphosphate Glasses.*—When a melt of composition  $\text{NaPO}_3$  is rapidly chilled a transparent glass is obtained. In manufacturing practice this can be done by running a continuous thin stream of the melt at about 700° on to a pair of parallel internally water-cooled steel rolls which rotate slowly; the metaphosphate glass is squeezed into a thin brittle sheet in the narrow gap between the rolls. This glassy form {Graham's salt} was first reported by T. Graham (Phil. Trans. 1833, 123, 253), and has since been the subject of many investigations. It is often designated as sodium hexametaphosphate. There is reason to believe that the solution obtained by dissolving the glass in water contains a mixture of polymers mostly of higher molecular weight than  $(\text{NaPO}_3)_n$  (cf. O. Lamm, Arkiv Kemi, Min. Geol. 1944, 17, A, No. 25). Dialysis experiments by K. Karbe and G. Jander (Kolloid-Beih. 1942, 54, 1) lead to the conclusion that the polymerisation is much greater than sixfold, and is sensitive to the conditions of preparation, especially the temperature from which the melt is chilled, and the closeness of the composition ratio  $\text{Na}_2\text{O}:\text{P}_2\text{O}_5$  to unity.

The softening point of the glass is slightly above 600°c. It is extremely soluble in water. The solutions are comparatively stable when cold, but hydrolysis to acidic products including acid pyrophosphate and monosodium orthophosphate occurs to a substantial extent in a few hours at the boiling-point. Hydrolysis is catalysed by hydrion and hydroxyl ion, the stability maximum being a little on the alkaline side of neutrality.

Molten sodium metaphosphate at 700°c. retains a small proportion of water for a long time. This is so even when the ratio of  $\text{Na}_2\text{O}$  to  $\text{P}_2\text{O}_5$  is accurately unity. On slow cooling, water vapour is evolved whilst crystallisation of sodium trimetaphosphate proceeds. It may be surmised that the water is combined and that the molten substance really contains polyphosphates in which a minor proportion of the negative charges are neutralised by  $\text{H}^+$  ions. The glass obtained by rapid chilling of the melt retains some of the water. For every combined  $\text{H}_2\text{O}$  molecule in a compound  $(\text{NaPO}_3)_x \cdot (\text{H}_2\text{O})_y$ , there must be formed two dibasic groups  $-(\text{PO}_4)^{2-}$ , each with one  $\text{H}^+$  ion attached, and this will have an acid strength of  $pK$  between 6 and 8. Actually, metaphosphate glasses with the correct  $\text{Na}_2\text{O}$  to  $\text{P}_2\text{O}_5$  ratio do give slightly acid solutions. Also, although the titration curve is essentially that of a strong acid (E. P. Partridge, Dual Service News, Hall Laboratories, Pittsburgh, 1937) deviations from the titration curve of sodium trimetaphosphate, in the expected direction, have been found (H. Rudy and H. Schloesser, Ber. 1940, 73 [B], 484).

The description of polymeric meta- and poly-

phosphates in terms of the electron-Octet picture is suggestive. A chain in which the \* repeating unit is  $(\text{PO}_3)^-$  is easily formulated with completed octets on both P and O atoms, by introducing the concept of electron pairs donated in the sense  $\text{O} \rightarrow \text{P}$ . But, were the substance exactly  $(\text{NaPO}_3)_z$ , an open-chain polymer so formulated would have one end terminated by the group  $(\text{PO}_4)^-$ — and at the other end the group  $(\text{PO}_3)$  with 6 electrons in the outer shell of the P atom and zero net charge on the group. Joining the ends by an  $\text{O} \rightarrow \text{P}$  linkage gives a symmetrical cyclic structure with all octets completed, and eliminates the weak acid function of the terminal  $(\text{PO}_4)^-$  group. The fact that "weak acid" behaviour is not found in the titration curves of sodium trimetaphosphate and sodium tetrametaphosphate is the main reason for ascribing to them cyclic structures, since an open-chain polymer will have at least one  $-(\text{PO}_4)^-$  group. Moreover, it seems not unlikely that the terminal  $(\text{PO}_3)$  group would immediately react with water by co-ordinating oxygen, completing all octets, and forming the terminal group  $(\text{PO}_4)^{2-}(\text{H}^+)_2$ . In this connection, it is interesting that attempts to prepare a monomeric  $\text{HPO}_3$  or  $\text{NaPO}_3$  have been unsuccessful. From this point of view the metaphosphates exist only as cyclic structures. The titration curves of polyphosphates will approximate more closely to the curve for trimetaphosphate as the chain length of the polymer increases, since the proportion of "weak acid" groups is inversely proportional to the chain length. An attempt has been made to utilise the form of the titration curve to ascertain the chain length (O. Samuelson, Svensk Kern. Tidskr. 1944, 56, 343), and, for  $\text{NaPO}_3$  glass, molecular weights of over 10,000 were found.

Pure metaphosphate glasses are not often used industrially; most of the commercial products contain a higher ratio of  $\text{Na}_2\text{O}$  to  $\text{P}_2\text{O}_5$  than unity. For example, in England, the U.S.A., and Germany a product known as "Calgon" has been widely used for the past ten years; this usually has an  $\text{Na}_2\text{O}:\text{P}_2\text{O}_5$  mol. ratio approximately 1\*1:1; other metaphosphate glasses are marketed with a somewhat higher ratio. All these products must in the main consist of mixtures of polyphosphates, but they differ little from pure metaphosphate glasses in many respects. They have, however, practical advantages over the latter, being more rapidly soluble and developing acidity in solution more slowly. "Calgon" and similar condensed phosphate glasses are marketed as "plate," which is the sheet glass broken into small pieces, or in a granular form, or ground to a powder. In all forms it is very hygroscopic. The applications of "Calgon" most of which depend upon an ability to form stable complexes with calcium and magnesium ions, are discussed later together with the applications of other sodium metaphosphates and tripolyphosphate.

*Insoluble Sodium Metaphosphate (Maddrell Salt).*—When monosodium phosphate is dehydrated at a temperature not exceeding 400°c., the final product consists of a mixture of soluble sodium trimetaphosphate (which can be removed by washing) and an insoluble metaphosphate

possessing a characteristic X-ray pattern. The proportion of insoluble metaphosphate is very sensitive to the exact conditions of dehydration, and may vary in a seemingly capricious way from 5 to 98%. The relation between sodium trimetaphosphate and insoluble sodium metaphosphate is not quite clear; the latter is certainly rapidly converted into the former at temperatures above about 450°C, and there are indications that the reverse change occurs very slowly below about 410°C.

Insoluble sodium metaphosphate may be a mixture of more than one polymer, but there is no reliable evidence. Although frequently designed as sodium nonometaphosphate (this is certainly wrong). It must be a highly polymerised form, because on dissolving by the aid of ammonium chloride [*vide infra*] a treacly phase separates on addition of alcohol, and this after washing to remove ammonium chloride redissolves in water to give a viscous solution. It is sometimes referred to as *Maddrell salt*, having been prepared by R. Maddrell (Phil. Mag. 1847, [iii], 30, 322) by heating sodium nitrate and concentrated phosphoric acid. The original preparation by heating monosodium orthophosphate was due to T. Graham (*l.c.*). The only substantial established application of insoluble sodium metaphosphate is in dentifrice.

A peculiar property of Maddrell salt is that although practically insoluble in boiling water (and only very slowly hydrolysed) it dissolves comparatively freely in the presence of salts of univalent cations other than sodium, for example potassium nitrate or carbonate, or ammonium chloride or nitrate; moreover a mixture of finely ground Maddrell salt with insoluble potassium metaphosphate (the latter resembles Maddrell salt in method of preparation and insolubility in water) will gradually dissolve on boiling giving a solution of both sodium and potassium metaphosphates. Calcium ions in small proportion also increase the rate of passage into solution. The interpretation of these facts is not clear. The observation concerning the effect of potassium and ammonium ions was made by A. G. Taylor (B.P. 543218, 1940) where it is also shown that the stability against hydrolysis of the dissolved metaphosphate is higher than that of glassy metaphosphate.

*Kurrol Salt.*—This is a remarkable form of sodium metaphosphate, which may be described as insoluble, in a restricted sense. It was first mentioned by Q. Tammann (J. pr.

Chem. 1892, [ii], 45, 467) and attributed to a collaborator after whom it was named. *Kurrol salt* is a fibrous crystalline substance, with a characteristic X-ray pattern. In cold water it very slowly swells, so that the asbestos-like crystals soften and pass into a gel, which ultimately disperses to a highly viscous solution. The presence in the water of small concentrations of ions other than sodium, *e.g.*, potassium, ammonium, or calcium, assists this process. Analogous behaviour has been described for insoluble potassium metaphosphate, which is a substance more akin to sodium Kurrol salt than to Maddrell salt. In the presence of small concentrations of sodium or ammonium ions, swelling of the metaphosphate occurs, and ultimately dispersion to a viscous solution (A. G. Taylor, U.S. G.P. 743002, 1943, to H. Huber and B. L. von Reppert). The viscosity is much reduced by boiling before any substantial hydrolysis to pyro- and ortho-phosphate has occurred. In the cold, the solutions retain their high viscosity for months.

Sodium Kurrol salt is not difficult to prepare even on a manufacturing scale if the conditions are properly adjusted. Sodium metaphosphate, or materials which give it on dehydration (which may have a very slight excess of  $P_2O_5$ , but must not have a deficiency), is melted, and allowed to cool at a moderate rate until solid. (Too rapid cooling gives glass, and too slow cooling gives trimetaphosphate only.) A small proportion of Kurrol salt mixed with some glass and some fed metaphosphate is the usual result. From this the Kurrol salt can be stained by washing away the freely soluble metaphosphate. Repetition of the fusion and moderately slow cooling, but now seeding the melt generously with powdered Kurrol salt just before solidification begins, gives a large proportion of well crystallised Kurrol salt. Once the melt has solidified, the further cooling should be rapid, to prevent transformation into trimetaphosphate. The reality of sodium Kurrol salt has more than once been incautiously denied. An account of the preparation and of some properties of sodium Kurrol salt is given by H. Huber and K. Klumpner (Z. anorg. Chem. 1943, 251, 213).

*Relations among the Sodium Metaphosphates.*—The diagram below summarises the relations among those forms of sodium metaphosphate the existence, except for sodium tetrametaphosphate, and properties of which have been established beyond question. Several other

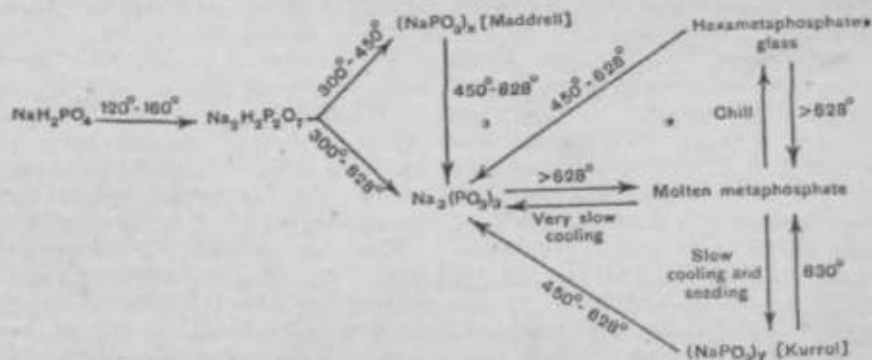

FIG. 9.

forms have been reported, but their existence is doubtful. The transformation of trimetaphosphate to Maddrell salt below 410° has been omitted from the diagram, as being still in need of confirmation.

**Sodium Tripolyphosphate.**—This compound is often, and perhaps better, called sodium triphosphate. It is usually encountered as a finely divided anhydrous powder, which hydrates slowly to  $\text{Na}_6\text{P}_3\text{O}_{10}\cdot 6\text{H}_2\text{O}$  by absorption of water vapour, but remains almost free-flowing. The hexahydrate is also formed by evaporation of the aqueous solution below about 60°.

Sodium tripolyphosphate was first reported by F. Schwarz (*ibid.* 1895, 9, 249), but its existence was doubted by many workers until confirmation was supplied by H. Huber (*Angew. Chem.* 1937, 50, 323) and K. R. Andress and K. Wüst (*Z. anorg. Chem.* 1938, 237, 113; 1939, 241, 196). The work of E. P. Partridge, V. Hicks, and G. W. Smith (*J. Amer. Chem. Soc.* 1941, 63, 454), using X-ray and thermal analysis

methods, has brought enlightenment about the conditions of formation and stability of sodium tripolyphosphate; their results have recently been confirmed by G. W. Morey and E. Ingerson, using optical methods (*Amer. J. Sci.* 1944, 242, 1). The situation is most easily understood in terms of the phase diagram of Fig. 10, taken from the paper of E. P. Partridge *et al.* Composition for any system in the range  $\text{Na}_2\text{O}:\text{P}_2\text{O}_5=2:1$  to  $\text{Na}_2\text{O}:\text{P}_2\text{O}_5=1:1$  & expressed in terms of the components  $\text{Na}_2\text{P}_2\text{O}_7$  and  $\text{NaPO}_3$ , the percentage by weight of  $\text{Na}_2\text{P}_2\text{O}_7$  being plotted as abscissae; thus  $\text{Na}_5\text{P}_3\text{O}_{10}$  appears at 72.3%  $\text{Na}_2\text{P}_2\text{O}_7$ . It will be seen that on cooling a melt which has the empirical composition of  $\text{Na}_5\text{P}_3\text{O}_{10}$ ,  $\text{Na}_4\text{P}_2\text{O}_7$  separates first, leaving a liquid richer in  $\text{NaPO}_3$ ; to obtain pure sodium tripolyphosphate, the melt should be cooled slowly from the peritectic temperature of 622° down to about 550°, so that the crystals of  $\text{Na}_4\text{P}_2\text{O}_7$  have time to redissolve in the remaining liquid as it becomes progressively richer in

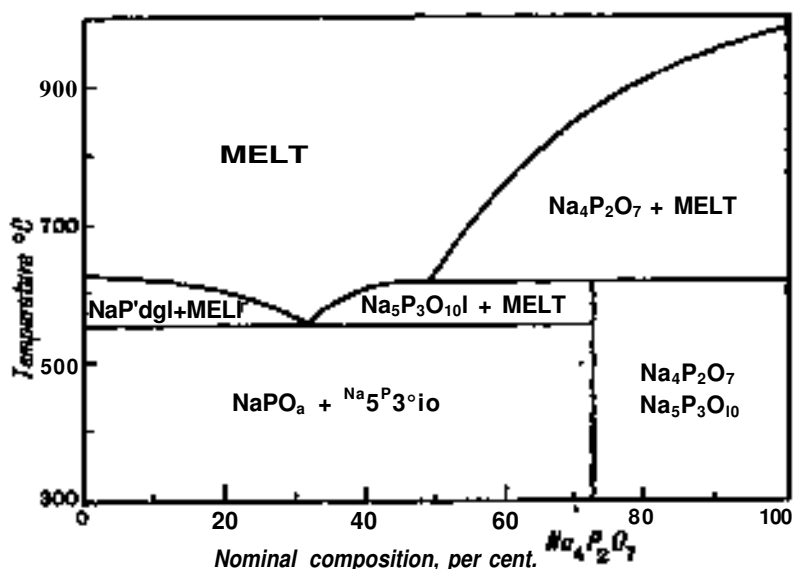

FIG. 10.

**NaPO<sub>3</sub>.** If the cooling in this temperature range is too rapid, the product contains much crystalline  $\text{Na}_4\text{P}_2\text{O}_7$  and glassy material rich in  $\text{P}_2\text{O}_6$ . When the proportion of true sodium tripolyphosphate is high, the solid breaks up into a powder as cooling towards ordinary temperature proceeds; doubtless this is caused by a polymorphic change discovered by E. P. Partridge *et al.* (*l.c.*).

**Sodium Tetrapolyphosphate (Sodium Tetraphosphate).**—In the literature and in patents there are numerous references to sodium tetrapolyphosphate, but it is generally believed now that no true compound of formula  $\text{Na}_6\text{P}_4\text{O}_{13}$  has yet been isolated. Commercial phosphate glasses referred to as sodium tetrapolyphosphate have the same uses as "Calgon."

Calcium Complexes formed by Metaphosphates and Polyphosphates. — The property, possessed by solutions of glassy sodium metaphosphate, of forming stable complex ions with calcium and magnesium was discovered

and utilised by R. E. Hall (*see* B.P. 424677 and 424959, 1935, to Hall Laboratories Inc., of Pittsburgh). The stability of the complex ions is such that calcium salts as little soluble as the oxalate and carbonate, and some calcium soaps, are dissolved by dilute metaphosphate solutions. The property of forming such (anionic) complexes is shared by all the sodium meta- and poly-phosphate glasses, and by the solutions, described above, of Maddrell salt and sodium Kurrol salt. It is also possessed by sodium tripolyphosphate. The term "sequestering" introduced by Hall Laboratories to designate the virtually complete elimination of  $\text{Ca}^{++}$  ions whilst retaining the calcium in solution in the form of a soluble complex, has become current in relevant United States and English industrial literature. The sequestering action is not confined to calcium and magnesium, and it is used to suppress other unwanted ions in special applications, such as bivalent copper. Ferric iron is sequestered (for example the ferric thiocyanate

complex is (Jecolourised by metaphosphate), but the stability of the metaphosphate ferric complex is ifpt sufficient to prevent precipitation of ferric hyaroxide if the pH is high. As a qualitative description of the action upon calcium ions, one part by weight of  $\text{Ca}^{++}$  is sequestered by approximately 14 parts of  $(\text{NaPO}_3)_x$  the criterion of the elimination of  $\text{Ca}^{++}$  ions being the usual soap-lather test.

As an order-of-magnitu4e measure of the stability of the calcium complexes, the dissociation constant at 25°c. of the complex ion consisting of  $\text{Ca}^{++}$  sequestered by sodium tripolyphosphate is  $3 \times 10^{-7}$  g.-mol. litre<sup>-1</sup>. The experimental method used was measurement of the solubility of calcium oxalate in dilute sodium tripolyphosphate solutions. Determinations of the effect of sodium tripolyphosphate upon the potential of a vine electrode gave a value of  $K$  for the  $\text{Ca}^{++}$  complex of the same order of magnitude. Thus the addition of 2 millimols. of  $\text{Na}_5\text{P}_3\text{O}_{10}$  to a solution of 1 millimol. of  $\text{Ca}^{++}$  in a litre reduces the  $\text{Ca}^{++}$  ion concentration to 0\*03% of its original value. The measurement was made in a solution adjusted to pH 11. Pure sodium metaphosphate glass, in a solution of pH 10, forms an even more stable calcium complex than  $\text{Na}_5\text{P}_3\text{O}_{10}$  at pH 11. When the sequestering agent is a polyphosphate, the action is much more pronounced in alkaline than in neutral or slightly acid solution; with substantially pure metaphosphate the effect of high pH is much less. If the suggestion is acceptable that the complexes are merely an extreme case of "ion association" by electrostatic attraction, the stronger pH effect with tripolyphosphate is readily explicable. Two of the five negative charges of the  $(\text{P}_3\text{O}_{10}^{4-})$  anion are associated with acidic functions having\* dissociation constants comparable with  $3 \times 10^{-7}$ , so that hydrogen ion competes effectively with  $\text{Ca}^{++}$  ion for the available negative charge. The converse, *i.e.*, a decrease of pH when  $\text{Ca}^{++}$  is sequestered, also occurs. That this pH effect is much less conspicuous with pure glassy metaphosphate than with polyphosphate, is in accordance with the much higher dissociation constant of the hydrogen ion from the singly charged  $\text{PO}_3$ -groups of a metaphosphate polymer. \*

In support of the view that electrostatic attraction offers a sufficient explanation of the force responsible for the sequestering effect, attention is drawn to the circumstance that the meta- and poly-phosphates in question are essentially flexible structures carrying a multiplicity of negative charges. Such structures can adapt themselves with little strain so that two or more of the seats of negative charge lie in close proximity to a positive ion. With bi-bivalent electrolytes such as calcium sulphate or zinc sulphate there is little doubt that association into ion pairs as envisaged by N. Bjerrum does occur to a substantial extent. Estimates of the dissociation constant  $K$  have been made for zinc sulphate, ranging from 0-003 to 0-005 g.-mol. litre.\* (*see* H. S. Harned and B. B. Owen, "The Physical Chemistry of Electrolytic Solutions," Reinhold Publishing Corporation, 1943, p. 425). If the sulphate ion is replaced by a flexible

multiply charged anion such as tripolyphosphate  $^--\text{O}_3\text{PO}(\text{PO}_3^j)\text{OPO}_7^{\text{---}}$ , it is *d fortiori* to be expected that bivalent cations will form associated ion pairs. Since the anion now has its charge distributed over more than one centre, the expression relating  $K$  to the valency factor<sup>^</sup>  $|Z_x Z_z|$  in N. Bjerrum's theory is not directly applicable. However, the electrical contribution to the free energy may be at least twice as large as with a bi-bivalent ion pair, whilst the main factor favouring the dissociated state, namely, the entropy increase on separation into two independently moving ions, is not very different whether the anion is sulphate or a meta- or poly-phosphate ion. Further consideration of this situation shows that there is no difficulty in understanding, qualitatively at least, the sequestering of bi- or poly-valent cations in terms of the simple picture of association into ion pairs, in which the only source of energy balancing the entropy increase on dissociation derives from the mutual electrostatic attraction of the opposite charges. Univalent cations, on the same basis, will be associated in ion pairs with the polyphosphate ion to the extent of a few per cent, only; this is in agreement with the absence of appreciable sequestering of silver. An important factor affecting the usefulness of meta- and poly-phosphates is their liability to slow hydrolysis. Hydrolysis of the meta- or poly-phosphate complex anions to pyrophosphate and orthophosphate sets free calcium, which may precipitate out either as calcium pyrophosphate or orthophosphate or hydroxyapatite, or as some other very insoluble compound such as a calcium soap. In most industrial applications of sequestering, the water is alkaline, and hydrolysis depends upon attack by  $\text{OH}^-$ . The association of  $\text{Ca}^{++}$  with the meta- or poly-phosphate anion would be expected to lower the activation energy of the hydrolytic reaction in virtue of the reduced electrostatic repulsion exerted by the complex ion upon the  $\text{OH}^-$ . Moreover, an amount of calcium much less than could be sequestered by the complex phosphate present might be effective in increasing the hydrolytic instability of the whole, since it will be continually re-sequestered to act as a catalyst for hydrolysis until there is no longer sufficient complex phosphate left to hold in solution even the small quantity of calcium. Experience amply confirms this expectation for alkaline solutions. In metaphosphate solutions adjusted to lower pH values than the pH of the hydrolytic stability maximum, similar small proportions of calcium would not be expected to have any appreciable effect. The hydrolytic attack is then by  $\text{H}_3\text{O}^+$ , and the only result of the sequestering will be to increase the hydrolytic stability of a small fraction of the complex phosphate present. Such evidence as is available verifies this prediction also.

Uses of Sodium Metaphosphates and Polyphosphates.—When sodium meta- or poly-phosphate glass is added to hard water the virtually complete elimination of free  $\text{Ca}^{++}$  and  $\text{Mg}^{++}$  ions is equivalent to softening the water. Use is made of this in many detergent operations where hardness of the water would reduce the effectiveness of soap and alkalis. Moreover, in

textile and laundry processing, deposits already formed can be removed, and "Calgon" is used in rinse water for this purpose.

Several applications depend upon the surface adsorption of meta- or poly-phosphates. Insoluble solids are deflocculated, so that finely divided pigments and clays and abrasives can be dispersed. Very small concentrations (in the range 0.26-10 p.p.m.) of "Calgon" have a remarkable power of delaying the growth of crystalline precipitates from solutions supersaturated with respect to calcium carbonate (v. R. F. Reiteineier and T. F. Buehren, *J. Physical Chem.* 1940, 44, 535). This effect, which is different in nature from the permanent sequestering of calcium, is used to avoid formation of scale when waters of high temporary hardness are heated, as in hot-water systems and condensers. Similarly, hard waters can be stabilised against the formation of scale when alkalis are added, and advantage is taken of this in cases such as the partial softening of domestic water supplies by lime when "after-precipitation" is to be avoided; in the wayside treatment of locomotive feed waters with sodium carbonate; and the addition of ammonia before chlorination. The separation of iron compounds out of well waters containing ferrous bicarbonate in solution is prevented by adding about twice as many parts per million of "Calgon" as there are of iron in the water. In the technical literature of water treatment, this action of sodium metaphosphate and polyphosphates is referred to as the "threshold effect" presumably to distinguish it from the "sequestering effect" which normally operates at much higher concentrations. The distinction in principle between the two is that the former acts by retarding the rate of an unwanted precipitation, the latter eliminates it by establishing a new equilibrium state.

An interesting application of sodium metaphosphate in "threshold" concentrations is the protection of metal surfaces by the formation of corrosion-inhibiting films. Besides iron and steel, zinc, copper, brass, aluminium, and lead can be given a considerable degree of protection from corrosion by a few parts per million of metaphosphate glass dissolved in the water. The conditions and the problems of municipal and industrial raw water supplies are very varied, but to an increasing extent "threshold treatment" is being tried for control of corrosion of water pipes and tanks, or for a combination of corrosion control and retardation of deposition. Numerous accounts of the "threshold effect" have appeared, particularly in journals devoted to water treatment; summaries and further references will be found in papers by G. B. Hatch and O. Rice (*Ind. Eng. Chem.* 1939, 31, 51 and 58; 1940, 32, 1572; 1945, 37, 710, 752; O. Rice and E. P. Partridge, *ibid.* 1939, 31, 58). See also \*E. G. B. Gledhill and A. W. H. McCanlis (*J. Inst. of Water Engineers*, 1944, pp. 278-359); also Committee Reports (*J. Amer. Water Works Assoc.* 1941, 33, 1534; 1942, 34, 1807) and H. Ingleson and G. Thomas (*Water and Water Engineering*, 1946, 14).

Phosphate conditioning of feed water for prevention of scale deposition, in high-pressure

boilers is sometimes done with sodium metaphosphate instead of di- or tri-sodium phosphate, when the conditions are such that metaphosphate will pass through the feed lines and neat economisers without premature deposition of calcium phosphate. In the boiler it is rapidly hydrolysed to the required orthophosphate, and a non-adherent boiler sludge is produced instead of hard scale. A discussion of the chemical conditioning of boiler-water, treatment, including different ways in which various phosphates are used, has been given by C. W. Tod (*Proc. Chem. Eng. Group*, 1936, 18, 52). For a more general review of the use of phosphates in water conditioning, with an extensive bibliography, see C. Schwartz and C. J. Hunter (*Ind. Eng. Chem.* 1942, 34, 32).

### IX. PHOSPHIDES.

Hydrogen Phosphides.—The most important are  $\text{PH}_3$ ,  $\text{P}_2\text{H}_4$ , and  $\text{P}_2\text{H}_6$ , although others have been reported.

Phosphine,  $\text{PH}_3$ . *Preparation.*—The most convenient laboratory method is the decomposition of phosphonium iodide (v. *infra*) by dilute aqueous alkali. The gas contains traces of  $\text{P}_2\text{H}_4$ , hydrogen, and hydrogen iodide, the latter despite the use of alkali in the water. Purification is by bubbling through concentrated hydrochloric acid (to remove  $\text{P}_2\text{H}_4$ ), then strong caustic soda solution to remove traces of acid; the gas is dried by calcium chloride followed by phosphorus pentoxide. Traces of hydrogen are removed if necessary by condensing the phosphine by liquid air and pumping off. For larger quantities the best method is treatment of mixed magnesium-aluminium phosphide (v. *infra*) with water:

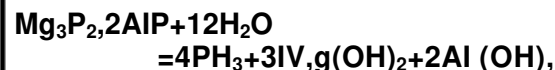

The water is slowly dropped on to the phosphide. The gas evolved is not spontaneously inflammable before drying. After drying it contains over 96% of  $\text{PH}_3$ , the remainder being hydrogen. An alternative to the use of magnesium-aluminium phosphide is the use of aluminium phosphide alone (see C. Matignon, *Compt. rend.* 1900, 130, 1393); it is then necessary to use dilute sulphuric acid, with risk of hydrogen production from any free metal present.

*Spontaneous Inflammability.*—Some of the applications of phosphine or of phosphides from which phosphine is generated depend upon the property of spontaneous inflammability. Pure dry phosphine is spontaneously inflammable in air (see M. Ritchie, *Proc. Roy. Soc.* 1930, A, 128, 551; also C. C. Stephenson and W. F. Giauque, *J. Chem. Physics*, 1937, 5, 149). Moist but otherwise pure phosphine does not ignite when mixed at atmospheric pressure and temperature with air; if the pressure is reduced, the mixture explodes. Phosphine which contains a small percentage (upwards of 0.2%) of  $\text{P}_2\text{H}_4$  is spontaneously inflammable, and this is the reason for the self-ignition of the gas prepared by the action of water upon commercial calcium phosphide and certain other metallic phosphides,

notably sodium phosphide containing a high proportion of combined phosphorus. It should be remarked that the  $P_4H_4$  is removed if the gas is allowed to bubble through any considerable depth of water. Moist but otherwise pure phosphine ignites in air on contact with a surface above about  $100^\circ C$ . A useful device for imparting the property of self-ignition to a stream of phosphine is to add to it a small percentage (0.1-1%) of nitric oxide. The mixture must be freshly prepared, because the gases slowly react.  $P_4H_4$  should be absent; it is probable that NO and  $P_2H_4$  are mutually destructive.

**Phosphonium Compounds.**—Phosphine combines with hydrogen chloride, bromide, and iodide to form phosphonium halides of the type  $PH_4X$ . These are rather unstable substances having dissociation pressures equal to 1 atm. at approximately  $-30^\circ C$ ,  $+40^\circ C$ , and  $+70^\circ C$ , respectively. Phosphonium iodide is conveniently made by dropping water (60 g.) on to the solid product obtained by the action of 100 g. of white phosphorus on 175 g. of iodine in carbon disulphide solution and distilling off the solvent. It sublimes in large transparent crystals, which fume in moist air.

**Toxicity of Phosphine.**—Phosphine is a highly toxic gas and special care is needed in handling zinc, calcium, magnesium, aluminium, and sodium phosphides, and also ferrophosphorus, which react with moisture and evolve phosphine. The odour provides a warning since the normal person can detect 1-10 p.p.m., and it is at the level of 10-100 p.p.m. that danger of poisoning arises. The symptoms of acute phosphine poisoning are biliousness, weakness, and cold sweat, usually followed by stupor, depression, and thirst. It is reported (F. Flury, *Anz. Schädlingskunde*, 1937, 13, 26) that phosphine acts on the central nervous system and that death is usually due to paralysis of the respiration. No evidence exists to show that phosphine poisoning can be chronic; on the other hand W. Müller (*Arch. exp. Path. Pharm.* 1940, 195, 184) declares that in the case of rabbits the poisoning is cumulative.

**Properties.**—Phosphine is a colourless gas, condensing to a liquid, b.p.  $-87.72^\circ C$ . The low-temperature thermodynamic properties have been carefully studied by several authors, in particular by C. C. Stephenson and W. F. Giauque (*J. Chem. Physics*, 1937, 5, 149). Four different forms of solid phosphine are known, the melting-point of the form stable at the highest temperature being  $139.35^\circ K$ . under the triple point pressure of 27-33 mm. Slow interconversion of two of the low-temperature forms made possible an excellent verification of the Third Law of Thermodynamics.

**Vapour-pressure Data.**—For solid phosphine:

$$\log P \text{ (mm.)} = 7.86434 - 895.700/T$$

for  $128.67 < T^\circ K < 139.35$  (triple point). For liquid phosphine:

$$\log P \text{ (mm.)} = 10.73075 - 1,027.300/T - 0.0178530r + (2.9135 \times 10^{-5})T^2$$

for (triple point)  $139.35 < T^\circ K. < 185.562$ . Above the boiling-point the vapour pressure, according

to "International Critical Tables," Vol. III, 1928, is:

$t^\circ Q.$	-87.5	-60	-30	0	+10
$p$ (atm.)	100	3.47	9.7	21.6	27.4
$t^\circ C.$	+20	+30	+40	+51 (critical temp.)	
$V$ (atm.)	34.2	42.3	51.9	64 (critical pressure)	

**Solubility.**—Water at room temperature dissolves about one-quarter of its own volume of phosphine at atmospheric pressure. The density of liquid phosphine is given by  $p = 0.693 - (6 \times 10^{-5})t$ , for  $-106 < t^\circ C. < -80$  ("International Critical Tables," Vol. III, 1928).

The free energy of formation of phosphine from its elements is important in connection with the possible industrial interest of the reaction between phosphorus and water, giving as desirable products phosphoric acid and hydrogen. Experimental determinations of the equilibrium:

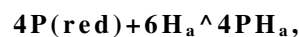

were made by W. N. Ipatiev and A. W. Frost (*Ber.* 1930, 63 [B], 1104). The data have been analysed by D. P. Stevenson and D. M. Yost (*J. Chem. Physics*, 1941, 9, 403) with the aid of molecular constants available in the literature, and summarised in their paper. Bringing into account also the vapour pressure data for red and white phosphorus, Stevenson and Yost's interpretation of the data gives for the gas phase reaction:



$\Delta F^\circ = -RT \ln K_p = -1 \times 10^{-11}$  (atm.)<sup>-3</sup> at  $354^\circ C$ . and  $1.9 \times 10^{-12}$  (atm.)<sup>-3</sup> at  $498^\circ C$ . Calculation for  $25^\circ C$ . gives the standard free energy change for the reaction:

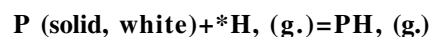

as  $\Delta H^\circ = -3,140$  g.-cal. per g.-mol. so that, so far as equilibrium data are concerned, there is a definite tendency for white phosphorus to combine with hydrogen at ordinary temperature and pressure. D. P. Stevenson and D. M. Yost (l.c.) tabulate values of  $(H^\circ - H^\circ_0)$  and  $-(G^\circ - U_j)/T$  for graduated temperatures from  $298.15$  to  $1,500^\circ K$ .

A rather complete summary of these and other physical properties of phosphine is given by D. M. Yost and H. Russell, "Systematic Inorganic Chemistry of the Fifth and Sixth Group Non-metallic Elements," Prentice-Hall, Inc., 1944, pp. 245-248.

**Tetrahydrogen Diphosphide,  $H_2P_2$ .**—This hydride, which is a liquid, b.p.  $58^\circ C$ , can be condensed out of the (dried) impure phosphine obtained by acting on commercial calcium phosphide (q.v.) or by acting on white phosphorus with strong warm caustic alkali solution. The preparation and properties are described in detail by L. Gattermann and W. Hausknecht (*Ber.* 1890, 23, 1174). It is unstable and decomposes slowly into phosphine and the hydride  $P_2H_4$ . Its practical importance in connection with the self-ignition of phosphine has been referred to above. It seems, at least between  $12^\circ$  and  $16^\circ C$ ,



that the coefficient of expansion is negative. The vapour density agrees with the formula  $P_2H_4$ .

**Solid Hydrogen Phosphide,  $P_{12}H_6$ .**—This is obtained as a canary-yellow powder. In a more or less impure form it appears as a by-product of many reactions. The commercial method of preparation is by the action of hydrochloric acid upon commercial calcium phosphide. The product is impure and contains calcium. In the early years of the present century it was manufactured on a small scale in England, with a view to its possible use as a material for match manufacture, but it did not compete economically with phosphorus sesquisulphide. The ignition temperature in air is  $150-200^\circ$ . It has been suggested (P. Eoyen and K. Hill, *Z. anorg. Chem.* 1936, 229, 97; P. Boyen, *ibid.* 369) that solid hydrogen phosphide, prepared by the reaction  $15P_2H_4 = 18PH_3 + P_{12}H_6$ , in reality consists of a new amorphous form of phosphorus with adsorbed phosphine.

Solid phosphorus hydride is insoluble in most liquids, but it dissolves in  $P_2H_4$  and in molten white phosphorus. The formula  $P_{12}H_6$  is based on a molecular weight determination in molten phosphorus. It decomposes on heating, giving phosphine and phosphorus.

**Sodium Phosphides.**—The sodium phosphides described in the literature are claimed to be  $NaP_3$ ,  $Na_2P_5$ , and  $Na_3P$ .  $NaP_3$  is made from the elements in the presence of gaseous ammonia at a low temperature (C. Hugot, *Compt. rend.* 1895, 121, 206).  $Na_2P_5$  is made from the elements by reaction in vacuum at  $450^\circ$ . (L. Hackspill and R. Bossuet, *ibid.* 1912, 154, 209).  $Na_3P$  is made from  $NaH_2P$  by heating to drive off  $PH_3$  (A. Joannis, *ibid.* 1894, 119, 557).

Sodium phosphide has been used as the active constituent of sea-flares (*v. infra*). The percentage of phosphorus varies from 20 to 60%, according to the purpose for which the phosphide is required. The compounds of low phosphorus-content contain two distinct types of solid, whilst materials containing 30-60% of phosphorus have a shiny blue-black crystalline appearance.

These phosphides are made commercially by direct union of the elements. Unless the phosphorus content is very low the whole mass becomes fluid due to the heat of reaction. The product is removed from the reaction vessel under oil, since sodium phosphides inflame in damp air.

**Magnesium Phosphide,  $Mg_3P_2$ .**—This material (or the mixed  $Mg_3P_2, 2AlP$ ) is made commercially by applying a local hot-spot to an intimate mixture of the theoretical proportions of metal powder and red phosphorus contained in an iron vessel. The reaction spreads through the whole mass, which becomes bright red-hot (*nee* F. Bodroux, *Bull. Soc. chim.* 1902, [iii], 27, 568). The product is a shiny yellowish-grey fused crystalline mass which is stable in dry air but is slowly decomposed by damp air into phosphine and magnesium hydroxide. It will evolve about 50% of its weight of almost pure phosphine on reaction with water:

**Aluminium Phosphide, AlP.**—Prepared in

much the same way as  $Mg_3P_2$  \*{see Fonzen-Diacon, *Compt. rend.* 1900, 130, 1315). Its main interest lies in its use in fumigation, *v. infra*.

**Calcium Phosphide.**—The calcium phosphide of commerce is made by heating quicklime in phosphorus vapour; it contains a substantial proportion of calcium phosphate. The product is a brown solid which contains up to 25% by weight of combined phosphorus and will evolve about 10% of its weight as phosphine and  $P_2H_4$  when treated with water.

**Zinc Phosphide.**—Zinc phosphides containing various proportions of zinc and phosphorus are mentioned in the literature, but the only one commercially available is  $Zn_3P_2$ . It is made by heating an intimate mixture of zinc powder and red phosphorus. The reaction is highly exothermic. The product is a dark grey powder which reacts only very slowly with water, but rapidly with mineral acids, evolving phosphine.

**Iron Phosphides.**—The four phosphides of established composition are  $Fe_3P$ ,  $Fe_2P$ ,  $FeP$ , and  $FeP_2$ ; all are hard, brittle, dark-grey solids. The ferrophosphorus of commerce does not conform exactly to any of the above formulas but usually contains 20-27% of P and is best considered as being mainly  $Fe_2P$  with some  $FeP$ . The remaining 70-80% is mainly iron, the major impurity being up to 2% of silicon. It is obtained as a by-product in phosphorus manufacture (*q.v.*). It is used as an auxiliary material in the manufacture of steel.

**Properties and Uses of Phosphides.**—The commercial value of the phosphides of sodium, potassium, magnesium, aluminium, calcium, and zinc lies in their ability to react with water to evolve a mixture of phosphine and hydrogen; this reaction is vigorous except in the case of aluminium and zinc phosphides. The gas is spontaneously inflammable in air in the case of the phosphides of sodium, potassium, and calcium as usually made, and this is due to traces of  $P_2H_4$  and possibly higher hydrides.

The gas evolved by the action of water on the phosphides of aluminium and magnesium (and from the mixed phosphide of these two metals which is manufactured commercially) is much purer, containing 96-98% of  $PH_3$ , the remainder being mainly hydrogen. This gas is not spontaneously inflammable in air but becomes so when about 0.1-1.0% of nitric oxide is mixed with it. The principle of admixing nitric oxide with phosphine has been applied in certain sea-flares since the reaction of sea-water with magnesium phosphide or magnesium-aluminium phosphide is the most efficient method known of producing phosphine for this purpose. The phosphine produced from devices of this kind burns in air to give (hydrated) phosphorus pentoxide and water vapour,

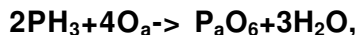

the smoke and the highly luminous phosphine flame being visible by day and night, respectively.

Aluminium phosphide has been used fairly extensively in fumigation. This is particularly so in Germany where technical aluminium phosphide is sold as "*Delicia*." Fumigation for

weevil in grain is done by burying packets of phosphide in the grain for periods of 12-24 hours and then recovering the packets by pulling long strings to which they are attached. The phosphide slowly evolves phosphine and is converted to aluminium hydroxide under the damp conditions prevailing. Fatal poisonings have occurred when granaries and dwelling houses have possessed a common wall through which phosphine has penetrated (*v. Toxicity of Phosphine*, p. 515a).

Zinc phosphide is used as a rat and mole poison and general vermin destroyer.

X. PHOSPHORUS HALIDES.

The number of possible phosphorus halides is considerable because of the existence of mixed halides. The following\* list contains those reported as definite:

	M.P., °C.	B.p., °C.
Trihalides:		
PF <sub>3</sub>	-152	-101
PCl <sub>3</sub>	-112	+74
PBr <sub>3</sub>	-40	+175
PI <sub>3</sub>	+61	decomp.
PF <sub>2</sub> Cl	-1440	+13.9
PF <sub>2</sub> Br	-133.8	-161
PFCl <sub>2</sub>	-164.8	-47.3
PBr <sub>2</sub>	-1150	+78.4
Pentahalides:		
PF <sub>5</sub>	-83	-75
PCl <sub>5</sub>	+166.8	decomp.
PBr <sub>5</sub>	decomp.	decomp.
PF <sub>3</sub> Cl <sub>2</sub>	—	-8
PF <sub>3</sub> Br <sub>2</sub>	-20	decomp.
PF <sub>3</sub> I <sub>2</sub>	—	—
PCLBr	—	—
PCl <sub>3</sub> Br <sub>2</sub>	+3.5	decomp.
	(decomp.)	
PCl <sub>2</sub> Br <sub>3</sub>	—	—
Di- or Tetra-halides:		
(PCl <sub>2</sub> )*	-28.0	decomp.
P <sub>2</sub> I <sub>4</sub>	+124.5	decomp.

A few higher halides, such as PCl<sub>2</sub>Br<sub>5</sub>, PCl<sub>6</sub>I, PCl<sub>3</sub>Br<sub>4</sub>, PBr<sub>7</sub>, are also known.

Structure and Molecular Constants.—The structures of some of these compounds have been determined, mainly by electron diffraction. Summarising tables of interatomic distances, bond angles, and vibration frequencies are given by D. M. Yost and H. Russell (*op. cit.*, pp. 238-240). Additional data have been determined by J. H. Sechrist and L. O. Brockway (*J. Amer. Chem. Soc.* 1944, 66, 1941). PF<sub>5</sub>, PCl<sub>5</sub>, and PBr<sub>5</sub> are pyramidal molecules having P-halogen distances respectively 1.52, 2.00, and 2.23 Å. and halogen-P-halogen angles respectively 104°, 101°, and 100°. PCl<sub>5</sub> is a trigonal bipyramid Cl(PCl<sub>3</sub>)Cl with the equatorial P-Cl distance 2.03 and the axial distance P-Cl 2.12 Å. The PF<sub>6</sub> molecule is similar to the PCl<sub>6</sub> molecule; the average P-F distance is

about 1.57 Å. PF<sub>3</sub>Cl<sub>2</sub> is also a trigonal bipyramid, the two Cl atoms being axially situated with P-Cl equal to 2.05 Å., whilst the P-F distance is 1.59 Å. Generalising from the few examples studied, the P-halogen distances in mixed halides do not differ much from those in the corresponding simple halides.

X-Ray analysis of the crystal structure of solid PCl<sub>5</sub> shows that the bipyramidal form of the isolated molecule in the vapour phase does not persist in the solid state. The unit cell of the crystal is tetragonal and contains two tetrahedral PCl<sub>2</sub> ions and two octahedral PCl<sub>3</sub> ions (D. Clark and H. M. Powell, and (independently) A. F. Wells, *J.C.S.* 1942, 642). It is interesting that a saturated solution of PCl<sub>5</sub> in nitrobenzene has a considerable electrical conductivity (G. W. F. Holroyd, H. Chadwick, and J. E. H. Mitchell, *ibid.* 1925, 2492).

Chemical Properties.—Halogen atoms combined with phosphorus interchange readily. For example, the reactions:

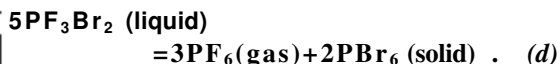
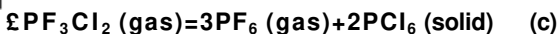
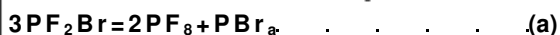

are observable (a) at -78°c., (b) below 400°c., (c) at 100°c., and (d) at room temperature. The following references to work on the mixed halides will be found useful: Prinvalet (*Compt. rend.* 1872, 74, 868); C. Poulenc (*Ann. Chim. Phys.* 1891, [vi], 24, 548); R. Moissan (*Compt. rend.* 1885, 100, 1348); H. S. Booth *et al.* (*J. Amer. Chem. Soc.* 1939, 61, 2927, 2934). The usual method of making the phosphorus halofluorides is fluorination of PCl<sub>3</sub> or PBr<sub>3</sub> with antimony trifluoride or calcium fluoride; a small proportion of antimony pentachloride is added to the PCl<sub>3</sub> as a catalyst for the chlorofluorides, and bromine as a catalyst for the bromofluorides. The thermal stability of the trihalides decreases as the atomic weight of the halogen increases. PI<sub>3</sub> readily decomposes, whilst PF<sub>3</sub> is an extremely stable gas. However, the great strength of the covalent bond between fluorine and many other elements results in the occurrence of some reactions of PF<sub>3</sub> which are not shared by the other halides. Examples are:

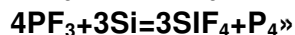
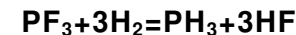

In respect of the dissociations PX<sub>6</sub> ⇌ PX<sub>3</sub> + X<sub>3</sub>, the stability decreases as the atomic weight increases. Thus PF<sub>5</sub> is formed with flame when PF<sub>3</sub> and fluorine are mixed. It has been reported that the reaction 5PF<sub>3</sub> = 3PF<sub>5</sub> + iP<sub>4</sub> takes place in the silent electric discharge. PCl<sub>5</sub> is somewhat dissociated in the vapour state, even at the temperature of sublimation of the solid, 159°c. PBr<sub>5</sub> is considerably dissociated into PBr<sub>3</sub> and bromine in solution at room temperature, and PI<sub>5</sub> is unknown. The mixed trihalides add two halogen atoms under

the same range of conditions as the simple trihalides.

Hydrolysis by water is rapid with the trihalides except  $\text{PF}_3$ , which is comparatively slowly attacked; phosphorous acid and the hydrogen halide are formed. The pentahalides are vigorously hydrolysed by water, forming first the oxyhalides, then phosphoric acid and the hydrogen halide. With  $\text{PF}_6$ , di- and monofluorophosphoric acids,  $\text{HPO}_2\text{F}_2$  and  $\text{H}_2\text{PO}_2\text{F}$ , are formed as intermediates in the further hydrolysis of phosphorus oxyfluoride.

**Phosphorus Trifluoride,  $\text{PF}_3$ .** *Preparation.*—Two reactions which are reported to give satisfactory results were developed by H. Moissan. (i) The reaction of arsenic trifluoride with phosphorus trichloride (Compt. rend. 1885, 100, 272):

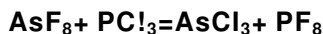

The arsenic fluoride is allowed to drop into the phosphorus trichloride. The stream of  $\text{PF}_3$  passes through a condenser at  $-50^\circ\text{C}$ , then through wash bottles containing successively water and sulphuric acid. The gas is then condensed by liquid air and fractionated, (ii) The reaction of lead fluoride with copper phosphide (Ann. Chim. Phys. 1885, [vi], 6, 433). Equal weights of perfectly dry lead fluoride and powdered copper phosphide (25-30% P) are heated to redness in a brass or copper vessel. The stream of  $\text{PF}_3$  is purified as in (i). The dry gas can be stored over mercury in glass vessels.

**Phosphorus Pentafluoride,  $\text{PF}_5$ .** *Preparation.*—The simplest preparation utilises the reaction by which T. E. Thorpe discovered this compound (Annalen, 1876, 182, 201):

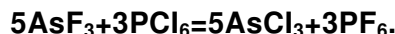

The gas is passed through a trap at  $-60^\circ\text{C}$ , then liquefied\* and fractionated. Another preparation (H. Moissan, Compt. rend. 1884, 99, 656) takes advantage of the spontaneous rearrangement of halogen atoms mentioned above:



A slow stream of phosphorus trifluoride is passed into bromine (previously dried by sulphuric acid) at  $-15^\circ$ , until the colour of the bromine has been destroyed. The liquid is then allowed to warm to room temperature and  $\text{PF}_5$  is evolved. Dry glass is not attacked, but the gas can be stored over mercury for a short time only.

**Phosphorus Trichloride,  $\text{PCl}_3$ .** *Manufacture.*—The only process of any importance is direct union of the elements. It is usual to make first a "crude" phosphorus trichloride, which is either used directly as an intermediate for making the oxychloride or purified for sale. The plant items used by different manufacturers vary in detail, but the main features are common probably to all. To moderate the vigour of the reaction, chlorination is done in the presence of a "pre-charge" of phosphorus trichloride, so that a substantial part of the reaction heat is removed by evaporation, with an appropriate proportion of reflux. Thus the reaction takes

place at the b.p. ( $74^\circ\text{C}$ ) of  $\text{PCl}_3$ ; the heat of formation is about ten times the latent heat of vaporisation. Additional cooling is provided by water outside the reaction vessel. In one form of plant molten white phosphorus and gaseous chlorine are simultaneously and continuously introduced into the reaction vessel, and conditions are controlled so that the phosphorus trichloride distilling over carries a fraction of 1% of dissolved white phosphorus. The distillate is treated in a stirred vessel with just sufficient chlorine to complete the chlorination. The yield of "crude" phosphorus trichloride is in practice about 97% with respect to both raw materials. Final purification is by redistillation with fractionation to remove traces of chlorinated organic matter and a small percentage of phosphorus oxychloride. All parts of the plant in contact with the reactants or product are preferably constructed of lead, lead-covered steel, bronze, or nickel.

**Phosphorus Pentachloride,  $\text{PCl}_5$ .** *Manufacture.*—A white, free-flowing crystalline product can be made by introducing chlorine into a vessel containing a mixture of phosphorus trichloride and carbon tetrachloride. The chlorine enters just above the liquid level. The vessel is cooled by a water-jacket and is provided with a reflux condenser, and an efficient stirrer which sweeps through the whole volume occupied by the liquid. When chlorination is complete the suspension of crystals of phosphorus pentachloride in carbon tetrachloride is run out through a valve at the bottom of the chlorination vessel, into a closed water-jacketed receiver which has a perforated false bottom covered by filter-cloth. The filtered carbon tetrachloride is returned to the chlorination vessel for the next cycle of operations, and the crystals are dried by circulating hot water through the jacket of the receiver. The equipment is constructed of lead-covered steel, with lead pipes.

A simpler type of plant, used up to 1945 by the I.G. Farbenindustrie, is described in B.I.O.S. Report No. 562 (Item 22). Two or more thin streams of re-distilled phosphorus trichloride are introduced through the cover of a tall and narrow reaction vessel, and simultaneously chlorine is introduced at the bottom. No stirrer is used; the phosphorus trichloride reacts as it falls through the atmosphere of chlorine. No special provision is made for cooling. The output from a chlorination vessel 250 cm. in height and 60 cm. in diameter is 3-4 kg. per hour. A receiver, 100 cm. in depth and of the same diameter as the chlorination vessel, is bolted on underneath the latter.

Phosphorus pentachloride is an effective reagent for converting alcohols and organic acids into the corresponding chlorides. The main uses are in dyestuff and other organic synthesis, and under special circumstances, as an intermediate in the manufacture of phosphorus oxychloride. It can be packed in drums made from ordinary terne plate.

**Phosphorus Dichloride,  $(\text{PCl}_2)_2$ .**—A. Beson and L. Founder (Compt. rend. 1910, 150, 102) submitted a mixture of  $\text{PCl}_3$  and hydrogen to the action of a silent electric discharge, and obtained a colourless oily fuming liquid and a

yellow solid\* The liquid, after distillation under reduced pressure, had the composition  $\text{PCl}_2$ . It boils at  $180^\circ$  with decomposition. In air it is liable to inflame spontaneously. In water it hydrolyses to hydrochloric and phosphorous acids, with simultaneous formation of a coloured solid thought to be impure phosphorus.

**Phosphorus Tribromide,  $\text{PBr}_3$ .** *Manufacture.*—The most convenient method is by adding bromine slowly to a cooled solution of white phosphorus in phosphorus tribromide, which serves to moderate the vigour of the reaction. It is best to continue the addition of bromine until a little phosphorus pentabromide and free bromine are present. (In spite of the large excess of tribromide, the pentabromide is appreciably dissociated in the warm tribromide.) The tribromide is purified by repeated distillation. For laboratory preparation of small quantities, dry phosphorus can be substituted for white phosphorus, and there is then no need to carry the addition of bromine so far. Phosphorus tribromide is a colourless liquid,  $d_4^{25}$  2.883. It is manufactured on a very small scale, for use as a reagent in organic chemical work.

**Phosphorus Pentabromide,  $\text{PBr}_5$ .** *Preparation.*—Bromine adds directly to phosphorus tribromide in the cold, forming pale yellow crystals of the pentabromide. It dissociates readily on warming, or in solution at room temperature. On the other hand, it is capable of taking up more bromine to form red crystals of the very unstable compound  $\text{PBr}_7$ .

**Phosphorus Tri-iodide,  $\text{PI}_3$ .** *Preparation.*—The best method of preparation is by direct union of either red or white phosphorus with iodine dissolved in carbon disulphide. The reaction is slow. Good crystals are obtained by cooling, which can be entirely freed from solvent by evaporation. It is essential to use carbon disulphide which does not contain free sulphur. F. E. E. Germann and R. N. Traxler (J. Amer. Chem. Soc. 1927, 49, 307) emphasise that carbon disulphide which has merely been redistilled is not free from sulphur, and they advise shaking it with mercury until it no longer tarnishes the metal, and then distilling. Phosphorus tri-iodide forms dark red crystals, stable up to a temperature somewhat above the melting-point. Water and moist air hydrolyse it to phosphorous acid and hydriodic acid, but other products are also formed.

**Phosphorus Tetraiodide,  $\text{PI}_4$ .** *Preparation.*—The same procedure can be used as for the tri-iodide, only two atoms of iodine being taken for one of phosphorus. Carbon tetrachloride can be substituted for carbon disulphide as solvent. The substance is obtained as orange crystals. According to L. Troost (Compt. rend. 1882, 95, 293) the molten substance vaporises as  $\text{P}_2\text{I}_4$ , on the evidence of the vapour density at  $265^\circ$ . On the other hand the tetraiodide is certainly less stable than the tri-iodide; it appears that under some circumstances  $\text{PI}_3$  sublimes from molten  $\text{P}_2\text{I}_4$  leaving red phosphorus, and the interpretation of the vapour density is uncertain. Hydrolysis gives phosphorous acid, hypophosphorous acid, and hydriodic acid (v. also Hypophosphoric Acid, p. 6066).

## XI.—PHOSPHORUS OXYHALIDES AND THIOHALIDES.

The following list contains those reported as definite:

	M.p., °C.	B.p., °C.
<b>Oxyhalides:</b>		
$\text{POF}_3$	-39.4	<del>-39</del>
$\text{POCl}_3$	+115	+107.4
$\text{POBr}_3$	+56	+193
$\text{POF}_2\text{Cl}$	-96.4	+31
$\text{POF}_2\text{Br}$	-84.8	+30.5
$\text{POFCl}_2$	-80.1	+52.9
$\text{POFBr}_2$	-117.2	+110.1
$\text{POClBr}$	$\sim$ +12	+137.6
$\text{POClBr}_2$	$\sim$ +30	$\sim$ +100 (decomp.)
<b>Thiohalides:</b>		
$\text{PSF}_3$	-148.8	-52.3
$\text{PSCl}_3$	-36.2; -40.8	+125
$\text{PSBr}_3$	+38	+212
$\text{PSF}_2\text{Cl}$	-155.2	+6.3
$\text{PSFCl}_2$	-96.0	+64.7
$\text{PSF}_2\text{Br}$	-136.9	+35.5
$\text{PSFBr}_2$	-75.2	+125.3
$\text{PSClBr}$	-30	+80/60 mm.
$\text{PSClBr}_2$	-6	+95/60 mm.

**Molecular Structures.**—Structures have been reported for several of the simpler oxy- and thio-halides of phosphorus having the general formula  $\text{APX}_2\text{Y}$ , where either or both of X and Y are F, Cl, or Br, and A is either O or S. Summaries of the numerical data are given by D. M. Yost and H. Russell (*op. cit.*, pp. 236-240). Additional data have been determined by J. H. Secrist and L. O. Brockway (J. Amer. Chem. Soc. 1944, 66, 1941). The P-X and P-Y distances are almost the same as in the trihalides (*q.v.*) and the P-O and P-S distances are approximately 1.56 and 1.90 Å, respectively.

**Phosphorus Oxyfluoride (Phosphoryl Fluoride),  $\text{POF}_2$ .** *Preparation.*—Several methods have been described. A convenient reaction is that of H. Moissan (Bull. Soc. chim. 1890, [iii], 4, 260) in which phosphorus oxychloride is dropped on to anhydrous zinc fluoride, maintained at  $40-50^\circ$ . The stream of gas is passed through a trap at  $-20^\circ$ ; it condenses out phosphorus oxychloride, and then through a tube filled with zinc fluoride to remove residual traces. Another preparation which would probably be more economical for larger scale production is that of T. E. Thorpe and F. J. Hambly (J.C.S. 1889, 55, 759); a mixture of three parts of phosphorus pentoxide and two parts of cryolite is gently heated. This reaction of fluorides to give phosphorus oxyfluoride appears to be fairly general, notwithstanding a report by H. J. Lucas and F. J. Ewing (J. Amer. Chem. Soc. 1927, 49, 1270) that phosphorus pentafluoride, rather than the oxyfluoride, is formed by heating 5 mol.  $\text{CaF}_2$  with 6 mol.  $\text{P}_2\text{O}_5$ . Phosphorus oxyfluoride is a poisonous gas readily hydrolysed by water. In contact with heated glass it forms silicon tetrafluoride.

Phosphorus Oxychloride (Phosphoryl Chloride),  $\text{POCl}_3$ .—Several oxychlorides of phosphorus have been described, but the only well investigated member of the group is  $\text{POCl}_3$ . This is commercially the most important of the compounds containing halogen and phosphorus. The chief use is in the manufacture of alkyl and aryl phosphates, and as a reagent in the production of certain dyestuffs and drugs.

*Properties.*—Phosphorus oxychloride is a colourless, fuming liquid,  $d_4^{20}=1.675$ , vapour pressure,  $\log_{10} p$  (mm.) =  $7.734 - 1.864/T^{\circ}$ , where  $323^{\circ} < T^{\circ} \text{K.} < 380^{\circ}$ . Phosphorus oxychloride reacts quickly, but not violently, with water, forming phosphoric and hydrochloric acids. It is in general less rapidly reactive with hydroxylic substances than phosphorus trichloride, but more corrosive towards metals, and more unpleasant to handle. The vapour affects the eyes, temporarily but painfully.

*Manufacture.*—Processes have been suggested for converting phosphorus pentoxide to phosphorus oxychloride by heating it with a metallic chloride, e.g.,

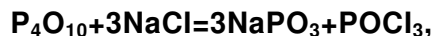

and for converting phosphates to phosphorus oxychloride by the action of carbonyl chloride or carbon monoxide and chlorine:



or by the action of carbon and chlorine:

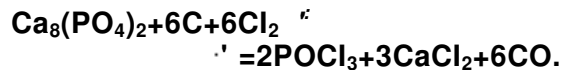

The reaction with ferric phosphate (at  $300\text{--}500^{\circ}\text{C.}$ ) is the basis of U.S.P. 1462732, 1923 (to E. I. du Pont de Nemours). An analogous process starting with tricalcium phosphate was described by J. Riban (Compt. rend. 1882, 95, 1160), and variations of this have been patented. The process utilising carbon and chlorine was studied on a pilot-plant scale by F. K. McTaggart (J. Counc. Sci. Ind. Res. Australia, 1945, 18, 424). It does not appear, however, that any such process has been successfully used on a commercial scale.

It is probable that all processes now used for making phosphorus oxychloride start with elemental phosphorus, which as a first stage is chlorinated to phosphorus trichloride. The trichloride is then oxidised to the oxychloride, or further chlorinated to phosphorus pentachloride and then hydrolysed to the oxychloride by using the stoichiometric quantity of water. The hydrolysis process is only economic when chlorine is very cheap, or where by-product hydrogen chloride has a value comparable with its equivalent of chlorine. Phosphorus trichloride can be oxidised directly by a variety of substances rich in oxygen. An early process, now discarded, utilised sodium chlorate. The vigour of the reaction was controlled by keeping a "pre-charge" of phosphorus oxychloride in the reaction vessel. Sodium chlorate is a useful reagent for removing the last traces of  $\text{PCl}_3$  from  $\text{POCl}_3$  made by other methods. Direct

oxidation of liquid phosphorus trichloride by gaseous oxygen is technically a satisfactory process; the yield approaches 100%, and the economics depend mainly upon the cost of oxygen in a sufficiently pure state. With modern methods of obtaining oxygen, this is probably as cheap as any other process provided that the scale of manufacture is large enough.

The kinetics of the reaction:

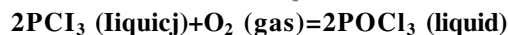

have not been reported. Complete absorption of pure oxygen takes place as the gas rises, in small bubbles, through a depth of 100 cm. of phosphorus trichloride. If the heat of reaction is removed by adequate cooling so that the temperature does not exceed about  $50^{\circ}\text{C.}$ , the ability of the liquid to absorb the oxygen shows little or no falling off until the proportion of  $\text{POCl}_3$  in the mixture of  $\text{PCl}_3$  and  $\text{POCl}_3$  exceeds 95.97%. Almost certainly the oxidation proceeds by a chain mechanism. Small quantities of some impurities greatly reduce the rate of reaction and may almost, completely inhibit it. Examples of such impurities are iron and copper, derived from contact with these metals; phosphorus pentachloride; and impurities derived from contact with vulcanised rubber. In the presence of these impurities the reaction rate (with gaseous oxygen bubbling into the liquid at a fixed rate) is no longer substantially independent of the extent to which the reaction has proceeded. There is often a long induction period, after which the rate increases to a maximum and then falls steadily as the reaction continues. A small amount of dissolved phosphorus in the phosphorus trichloride is not very objectionable; it appears to oxidise readily, and thereafter the main reaction occurs satisfactorily.

This process, as operated up to 1945 by the I.G. Farbenindustrie, is described in B.I.O.S. Report No. 562 (Item 22). Batches of "crude" phosphorus trichloride (v. Phosphorus Trichloride Manufacture, p. 5186) were oxidised in large lead-lined steel vessels, 10 cu. m. in capacity, externally cooled by water. Oxygen at 2 atm. pressure was admitted at numerous points round the perimeter near to the bottom of the vessel, either through porous ceramic candles or through nozzles directly into the liquid; with the latter arrangement the liquid has to be stirred. Approaching completion of the reaction is indicated by the temperature falling below the  $50\text{--}60^{\circ}\text{C.}$  at which it is controlled during the 60-80 hours reaction time, and by vigorous escape of oxygen from the surface of the liquid. The reaction is judged to be complete when the liquid solidifies at  $0\text{--}8\text{--}10^{\circ}\text{C.}$  The product was used or sold without distillation or other purification.

Phosphorus Oxybromide (Phosphoryl Bromide),  $\text{POBr}_3$ . *Preparation.*—Starting with phosphorus tribromide, the same reactions are applicable as with phosphorus oxychloride. Direct reaction with gaseous oxygen occurs at the boiling-point of the tribromide, but is not a very satisfactory method. The best method is that of E. Berger (Bull. Soc. chim. 1908, [iv], 3,

721), in which phosphorus pentabromide reacts with phosphorus pentoxide:

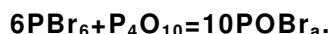

The two solid substances are mixed and gently heated; loss of bromine from the pentabromide is minimised by attaching a well-cooled reflux condenser, and by keeping the reactants as dry as possible (metaphosphoric acid reacts with phosphorus pentabromide, forming the oxybromide and hydrogen bromide, and evolution of the latter carries away bromine vapour). When the reaction, under gentle heating, appears to be complete, and the product is entirely liquid, the phosphorus oxybromide is distilled. The redistilled product solidifies to colourless crystals.

**Thiophosphoryl Fluoride (Phosphorus Sulphofluoride),**  $\text{PSF}_3$ . *Preparation.*—The most convenient method\* of preparing this substance is by the reaction of phosphorus pentasulphide with lead fluoride at  $170\text{--}250^\circ\text{C}$ . in the absence of oxygen and moisture (T. E. Thorpe and J. W. Rodger, J.O.S. 1889, 55, 306). The gas is collected over dry mercury in glass vessels. It is spontaneously inflammable in air at room temperature. Hydrolysis with water or alkali yields di- and mono-fluothiothiophosphoric acids,  $\text{HPOSF}^{\wedge}$  and  $\text{H}_2\text{PO}_2\text{SF}$ , thiophosphoric acid,  $\text{H}_3\text{PSO}_3$ , and orthophosphoric acid, or their salts.

**Thiophosphoryl Chloride (Phosphorus Sulphochloride),**  $\text{PSCI}_3$ . *Manufacture.*—For industrial purposes a very satisfactory process is the direct addition of sulphur to phosphorus trichloride, a process originally described by L. Henry (Ber. 1869, 2, 638). It has been shown by W. H. Woodstock and H. Adler (J. Amer. Chem. Soc. 1932, 54, 464) that alkali and alkaline-earth sulphides effectively catalyse the combination, which takes place in a few hours at  $150\text{--}160^\circ\text{C}$ . The use of these sulphide catalysts can be avoided by working at a slightly higher temperature ( $160\text{--}180^\circ\text{C}$ .) and using an excess of sulphur; caution is necessary, since the reaction is strongly exothermic, and the pressure rises abruptly when reaction sets in. Stainless steel is a suitable material for construction of the autoclave, although mild steel has been used successfully. The product can be distilled out of the autoclave, leaving a residue of sulphur which forms part of the following charge. The yield is practically quantitative. For small scale preparations, a reaction discovered by T. E. Thorpe (J.C.S. 1880, 37, 327) is convenient:



Thiophosphoryl chloride vapour is decomposed on heating strongly. There are two forms of the solid. It appears to be very insoluble in water, and is hydrolysed slowly to hydrochloric acid, phosphoric acid, hydrogen sulphide, and other products.

**Thiophosphoryl Bromide (Phosphorus Sulphobromide),**  $\text{PSBr}_3$ . *Preparation.*—The reaction of phosphorus pentabromide with phosphorus pentasulphide (T. E. Thorpe, *ibid.* 1871, 24, 1163) is the most convenient method; working details are given by H. S. Booth and C. A. Seabright {see "Inorganic Syntheses," Vol. II, McGraw-Hill Book Co., Inc., 1946}. Alternately,

the three elements involved may react in one step in carbon disulphide solution, with cooling (see A. Michaelis, *Annalen*, 1872, 164, 36).

Thiophosphoryl bromide is more resistant to hydrolysis than thiophosphoryl chloride; it can be washed with cold water with little loss. The products of hydrolysis by hot water include hydrogen sulphide, sulphur and phosphorous acid, as well as hydrogen bromide and phosphoric acid.

**Phosphorus Mixed Oxyhalides (Phosphoryl Mixed Halides).** *Preparation.*—H. S. Booth and co-workers (J. Amer. Chem. Soc. 1939, 61, 2937, 3120) prepared the oxyhalofluorides listed on p. 519. Phosphorus oxychloride (or oxybromide) was fluorinated by antimony trifluoride at  $60\text{--}100^\circ\text{C}$ . It was found necessary to add as catalyst a little antimony pentachloride to the phosphorus oxychloride (or bromine to the oxybromide). Calcium fluoride can be used (with less success) instead of antimony trifluoride, but at the higher reaction temperatures ( $120\text{--}150^\circ\text{C}$ .) required, more attack on glass vessels takes place. In either case the reaction produces a mixture of  $\text{POF}_3$ ,  $\text{POF}_2\text{Cl}$ ,  $\text{POFCl}_2$  (or  $\text{POF}_3$ ,  $\text{POF}_2\text{Br}$ ,  $\text{POFBr}_2$ ) with some  $\text{SiF}_4$ , and the individuals are separated by fractionation.

The compounds  $\text{POCl}_2\text{Br}$  and  $\text{POCIBr}_2$  were prepared by A. Besson (Compt. rend. 1896, 122, 814) by heating a mixture of  $\text{POCl}_3$  vapour with hydrogen bromide in contact with pumice at  $400\text{--}500^\circ\text{C}$ . and fractionating the products under reduced pressure.  $\text{POCl}_2\text{Br}$  was prepared by N. Menshutkin (*Annalen*, 1866, 139, 345; *Bull. Soc. chim.* 1866, [ii], 6, 481) by brominating alkyl dichlorophosphonates:

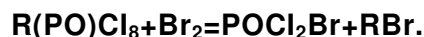

*Properties.*—The oxyhalofluorides are much less liable to disproportionation than the mixed trihalides. On the other hand, the oxybromochlorides do tend to rearrange to  $\text{POBr}_3$  and  $\text{POCl}_3$ . Hydrolysis by water occurs readily in all cases. Copper, mercury, and nichrome are only very slightly attacked.

**Phosphorus Mixed Thiohalides (Thiophosphoryl Mixed Halides).** *Preparation.*—H. S. Booth and co-workers (J. Amer. Chem. Soc. 1940, 62, 2369; 1943, 65, 1834) prepared the thiohalofluorides listed on p. 519. Phosphorus thiochloride (or thiobromide) was fluorinated by antimony trifluoride. For the chlorofluorides, antimony pentachloride was used as a catalyst, at  $75\text{--}80^\circ\text{C}$ .; for the bromofluorides no catalyst was needed. The reaction products consisted of a mixture of  $\text{PSF}_3$ ,  $\text{PSF}_2\text{Cl}$ ,  $\text{PSFCI}_2$  (or  $\text{PSF}_3$ ,  $\text{PSF}_2\text{Br}$ ,  $\text{PSFBr}_2$ ), and the relative proportions could be controlled within limits by regulating the pressure and hence the temperature of reflux in the generating apparatus.

The compounds  $\text{PSCI}_2\text{Br}$  and  $\text{PSCIBr}_2$  were prepared by A. Besson (Compt. rend. 1896, 122, 1057) by the same reaction as with the corresponding mixed oxyhalides (*q.v.*).  $\text{PSCI}_2\text{Br}$  was prepared by A. Michaelis (Ber. 1872, 5, 6) by a reaction analogous to N. Menshutkin's preparation of  $\text{POCl}_2\text{Br}$  (*q.v.*).

*Properties.*—The thiochlorofluorides are stable substances in the absence of air or moisture.

They are prone to spontaneous ignition in air, and hydrolysis occurs slowly with water, more rapidly, however, than in the case of  $\text{PSCI}_3$ . Mercury and nichrome are not affected in the cold; copper is slowly attacked. The thiobromofluorides are similarly thermally stable, and it is not recorded that they are liable to spontaneous ignition in air. Hydrolysis in the cold is very slow, especially with  $\text{PSFBr}_2$ , which showed no sign of hydrolysis by potassium hydroxide solution in 24 hours at room temperature; it is completely hydrolysed in a few hours at the boiling-point. Mercury is attacked above  $70^\circ\text{C}$ .; copper is seriously attacked at room temperature, nichrome is not.  $\text{PSF}_2\text{Br}$  is somewhat more reactive; mercury is attacked above  $35^\circ\text{C}$ . The two thiobromochlorides are subject to disproportionation on heating, although less readily than most of the mixed phosphorus tri- and penta-halides.

### XII. PHOSPHORUS AND PHOSPHORYL CYANIDES, CYANATES, AND RELATED COMPOUNDS.

Mention may be made of a little-investigated series of "pseudo-halogen" compounds of phosphorus. The following have been prepared:

	M.p., °C.	B.p., °C.
$\text{P(CN)}_3$	—	+ 130 (sublimes)
$\text{P(CN)}_5$	—	—
$\text{P(NCO)}_3$	—	+ 169
$\text{PCI(NCO)}_2$	—	+ 135
$\text{PCI}_2(\text{NCO})$	-99-2	+104
$\text{P(SCN)}_3$	-4	+ 265
$\text{PCL(SCN)}$	—	+ 148
$\text{PO(OCN)}_3$	—	—
$\text{PO(NCO)}_5$	+5	+ 193
$\text{PO(SCN)}_3$	+ 14	+300
$\text{POCl}_2(\text{SCN})$	-55	+ 173
$\text{PS(NCO)}_3$	+9	+215

Preparation.—The reaction of  $\text{PCI}_3$  with silver cyanide at  $100^\circ\text{C}$ . yields  $\text{P(CN)}_3$ , which is converted into  $\text{P(CN)}_5$  by treatment with dicyanogen under pressure (H. Gall and J. Schiippen, Ber. 1930, 63 [B], 482). The analogous reaction of  $\text{PCI}_3$  with silver thiocyanate can be carried out in benzene or ether solution (P. Miquel, Ann. Chim. Phys. 1877, [v], 11, 341; A. E. Dixon, J.C.S. 1901, 79, 541; H. Gall and J. Schiippen, *l.c.*). The remaining compounds listed above were prepared by the action of  $\text{PCI}_3$ ,  $\text{POCl}_3$ , or  $\text{PSCI}_3$  on silver isocyanate or silver thiocyanate (H. H. Anderson and co-workers, J. Amer. Chem. Soc. 1940, 62, 761; 1942, 64, 1757; 1943, 65, 2271; 1945, 67, 223).

Properties.—Most of these compounds have been found to polymerise to solids more or less easily, probably according to the adventitious presence of catalysts. The mixed compounds disproportionate more or less readily;  $\text{PCI(NCO)}_2$  rapidly changes to  $\text{P(NCO)}_3$  and  $\text{PCI}_2(\text{NCO})$ , but the last named is comparatively stable. The phosphoryl and thiophosphoryl compounds

are on the whole more stable than the corresponding tervalent phosphorus compounds.

### XIII. PHOSPHORUS SULPHIDES.

The literature dealing with these compounds is very contradictory, probably the best work having been done by A. Stock and co-workers. The fusion curve obtained by H. Giran (Compt. rend. 1906, 142, 398) shows maxima at  $167^\circ$ ,  $296^\circ$ ,  $272^\circ$ , and  $314^\circ$ , the corresponding compositions being, expressed by the formula  $\text{P}_4\text{S}_3$ ,  $\text{P}_2\text{S}_3$ ,  $\text{P}_2\text{S}_6$ , and  $\text{PS}_3$ —Of these,  $\text{P}_2\text{S}_3$  and  $\text{PS}_3$  are unknown as definite compounds, the known sulphides being  $\text{P}_4\text{S}_3$ ,  $\text{P}_4\text{S}_5$ ,  $\text{P}_4\text{S}_7$ ,  $\text{P}_4\text{S}_{10}$ , and possibly  $\text{P}_3\text{S}_6$ . Data for some of these compounds are given below; sources include A. Stock and B. Herscovici (Ber. 1910, 43, 415 and 122%) and W. D. Treadwell and Ch. Beeli (Helv. Chim. Acta, 1935, 18, H61).

	$\text{P}_4\text{S}_3$	$\text{P}_4\text{S}_5$	$\text{P}_4\text{S}_7$	$\text{P}_4\text{S}_{10}$
Colour of solid	Yellow.	Sulphur-yellow.	Nearly white.	Yellow.
Density of solid	2.03(17°)	2.17(25°)	2.19(17°)	2.09(17°)
M.p., °C.	171-172.5	167	305-310	286-290
B.p., °C.	407-408	—	523	513-515 (190 at 0.1 mm. Hg).
Solubility (g. per 100 g. solvent):				
CS <sub>2</sub> 0°	270	—	0005	0.182
17°	1000	~10	0020	0.222
C <sub>6</sub> H <sub>6</sub> 17°	2.5	—	—	—
80°	11.1	—	—	—
Action of cold water.	None.	Decomp.	Decomp.	Slow decomp.

Phosphorus Sesquisulphide (Tetraphosphorus Trisulphide),  $\text{P}_4\text{S}_3$ .—The validity of the formula has been confirmed by ebullioscopic measurements in benzene (A. Stock and H. von Bezold, Ber. 1908, 41, 657) and by vapour-density measurements at  $700^\circ\text{C}$ . Decomposition occurs at higher temperatures, as appears from similar determinations in the range  $700$ - $1,000^\circ\text{C}$ . Electron diffraction data by O. Hassel and A. Petterson (Tids. Kjem. 1941, 1, 57) indicate that the structure of  $\text{P}_4\text{S}_3$  in the vapour state consists of phosphorus atoms arranged at the corners of a tetrahedron, with sulphur atoms between one of these phosphorus atoms and each of the remaining three.

$\text{P}_4\text{S}_3$  is the most stable sulphide, cold water and cold hydrochloric and sulphuric acids having little action. It is slowly broken down by boiling water to give hydrogen sulphide, phosphorus oxy-acids, and phosphine. Nitric acid and *aqua regia* dissolve it, giving phosphoric acid and sulphuric acid, and some sulphur. Cold aqueous caustic potash causes evolution of phosphine and hydrogen, leaving sulphide, hypophosphite, and phosphite ions in solution.

Manufacture.—It is manufactured by direct union of the elements. Molten white phosphorus is run into molten sulphur contained in a stirred cast-iron vessel, the rate of addition being controlled to maintain the reaction temperature at  $320$ - $380^\circ\text{C}$ . When addition is complete the temperature is maintained in this



range by external heating for a further period. The product can now be purified by vacuum distillation or by washing, using either water or dilute bicarbonate solution. Vacuum drying at 40-50°C. follows any washing process. A description of this manufacture, as done by the I.G. Farbenindustrie up to 1945, is given in B.I.O.S. Report No. 562 (Item 22). The principle use of  $P_4S_3$  is in the match-making industry (v. Vol. VII, 5286)^

**Tetraphosphorus Pentasulphide,  $P_4S_5$ .**—W. D. Treadwell and Ch. Bedi (l.c.) confirmed R. Boulouch's preparation of  $P_4S_6$  (Compt. rend. 1904, 138, 363) by exposing a carbon disulphide solution of  $P_4S_3$ , sulphur, and a trace of iodine to the action of light. They also formed the compound by slow cooling of a melt of red phosphorus and sulphur in the proportions  $2P+3S$ , followed by recrystallisation from boiling carbon disulphide. The study of a  $P_4S_5$  melt led to the conclusion that under certain conditions an equilibrium exists between it and  $P_4S_3+P_4S_7$ . Ebullioscopic measurements in carbon disulphide show the compound to have the formula given.

**Phosphorus Heptasulphide (Tetraphosphorus Heptasulphide),  $P_4S_7$ .**—A. Stock and B. Herscovici (Ber. 1910, 43, 415) made  $P_4S_7$  by heating an intimate mixture of red phosphorus and sulphur in the theoretical proportions with 5% of  $P_4S_3$ . The product was purified by recrystallisation from carbon disulphide. Vapour-density measurements at 700° indicate that the vapour consists of  $P_4S_7$  molecules; some decomposition occurs at higher temperatures.

**Phosphorus Pentasulphide (Tetraphosphorus Decasulphide),  $P_4S_{10}$ .**—The formula  $P_4S_{10}$  is based upon ebullioscopic measurements in carbon disulphide. Vapour-density measurements at temperatures from 600-1,000° (A. Stock and H. von Bezold, l.c.) prove that the vapour is largely decomposed. It appears that phosphorus pentasulphide is not entirely stable even at room temperature in a sealed tube, and the behaviour on melting shows that decomposition takes place when heated. The paper of A. Stock and B. Herscovici (l.c.) should be consulted. With water it reacts slowly in the cold, but rapidly on heating, giving mainly hydrogen sulphide and orthophosphoric acid. Alkaline solutions react with phosphorus pentasulphide forming a mixture of products containing thiophosphates and sulphides; the former are further hydrolysed to sulphides and phosphate on boiling.

**Manufacture.**—It is manufactured in a similar manner to  $P_4S_3$ , i.e., by direct union of the elements in stirred cast-iron vessels. Water washing cannot be used for purification in this case and the commercial material usually contains small percentages of  $P_4S_3$  and free sulphur, which can be removed by carbon-disulphide extraction if purification is necessary.

In recent years  $P_4S_{10}$  has found substantial use in the manufacture of organic phosphorus-sulphur compounds, which are used as additives to lubricating oil to impart such properties as oxidation resistance, detergency, and the ability to withstand high bearing-pressures. These

compounds are produced by reaction of  $P_4S_{10}$  with alcohols, olefins, turpentine, etc. A further application is in the preparation of organic thiophosphates used for ore flotation.

B. R. and B. T. **PHOSPHORUS, ORGANIC DERIVATIVES OF.** In this article, only those compounds in which the phosphorus is directly linked to carbon are considered; esters of phosphorous and phosphoric acid, etc., will be found elsewhere. The symbol R is used throughout to denote an alkyl or aryl group.

**Phosphines.**—Our knowledge of the primary and secondary phosphines,  $RPH_2$  and  $R_2PH$ , is based largely on the early work of Hofmann carried out mainly in the years 1870-75\* and, in the absence of modern investigations, is incomplete and possibly inaccurate. The alkylphosphines are prepared by heating a mixture of phosphonium iodide,  $PH_4I$ , with zinc oxide and the appropriate alkyl iodide; a mixture of the primary and secondary phosphines results, from which the secondary can be isolated as an addition product with hydrogen iodide and zinc iodide. The lower primary alkylphosphines are gases, and the higher members liquid; they possess vile odours, and are basic, forming salts of type  $RPH_3I$ . Little is known of the secondary alkylphosphines. Primary arylphosphines can be prepared by the reduction of the dichlorophosphine,  $RPCl_2$ , or the phosphonic acid,  $RPO(OH)_2$ , or sometimes by the thermal decomposition of the latter. Secondary arylphosphines are prepared by the reduction of the monochlorophosphine,  $R_2PCI$ , in the presence of aqueous sodium carbonate, in effect, the reduction of the phosphinous acid,  $R_2POH$ .

**Chlorophosphines.**—The alkyl mono- and di-chlorophosphines,  $RPCl_2$  and  $R_2PCI$ , can be prepared by heating phosphorus trichloride with the appropriate amount of lead tetra-alkyl or mercury di-alkyl. The arylmonochlorophosphines are best prepared by heating a mixture of phosphorus trichloride, the appropriate hydrocarbon and aluminium chloride, followed by fractional distillation (Michaelis, Annalen, 1896, 293, 237; Jackson, Davies, and Jones, J.C.S. 1930, 229). The diarylmonochlorophosphines,  $R_2PCI$ , are most readily prepared by heating the dichlorophosphine with mercury di-aryl; this method is particularly valuable when the presence of two different aryl groups is required (Davies and Mann, J.C.S. 1944, 276).

The mono- and di-chlorophosphines are liquids which distil without decomposition, but fume on exposure to air; they combine with chlorine to form the less stable tetra- and tri-chlorophosphines,  $RPCl_3$  and  $R_2PCI_3$ , respectively. The dichlorophosphines and monochlorophosphines on hydrolysis give the corresponding phosphonous acids,  $RP(OH)_2$  and phosphinous acids,  $R_2P(OH)$ , which have been little investigated. If, however, the hydrolysis is conducted in the presence of an oxidising agent, the more

\* The Organic Chemistry Department of the Imperial College of Science and Technology possesses the original specimens of salts of alkylphosphines, prepared by Hofmann, a research student who worked under Hofmann at the Royal College of Chemistry.—EDITOR.

stable phosphonic acids,  $RPO(OH)_2$  and phosphinic acids,  $R_2PO(OH)$ , are obtained; these can also be prepared by the simple hydrolysis of the above tetra- and tri-chlorophosphines,  $RPCl_4$  and  $R_2PCl_3$ , or the chloro-bromoderivatives,  $RPCl_2Br_2$  and  $R_2PClBr_2$ .

The aryl di- and mono-chlorophosphines, because of their readier accessibility, have been more fully investigated than the alkyl analogues. Phenyl-dichlorophosphine,  $PhPQI_2$ , reacts with phenylphosphine,  $PhPH_2$ , to give phosphobenzene,  $PhP:PPh$ , and with phenylarsine,  $PhAsH_2$ , to give phospho-arsenobenzene,  $PhP:AsPh$ ; the latter, however, in hot benzene solution readily dismutates to phosphobenzene and arsenobenzene.

**Tertiary Phosphines,  $R_3P$ .**—These compounds, both alkyl and aryl, are best prepared by the action of the appropriate Grignard reagent on phosphorus trichloride or the di- or mono-chlorophosphines. The action of the reagent  $R'MgBr$  on  $RPCl_2$  or  $R_2PCl$  is particularly valuable when mixed tertiary phosphines,  $RR_2P$  and  $R_2R'P$ , are required. The compounds  $Me_3P$  and  $Et_3P$  are so readily oxidised, however, that normal methods of isolation fail. It is best, therefore, to subject the crude reaction product (without hydrolysis) to destructive distillation in an inert atmosphere, and then to collect the phosphine directly in a solution of silver iodide in aqueous potassium iodide; the stable complex,  $[R_3P, AgI]_4$ , can be collected, dried, and stored, and when subsequently heated, also in an inert atmosphere, yields the pure tertiary phosphine (Mann and Wells, *ibid.* 1938, 708). The higher trialkylphosphines and the (crystalline) triarylphosphines are much less susceptible to atmospheric oxidation.

The triarylphosphines can also be prepared by the Michaelis reaction, *e.g.*, by heating phosphorus trichloride (or phenyl-dichlorophosphine) with bromo benzene and sodium in ether (Michaelis *et al.*, Ber. 1882, 15, 801, 1610; 1884, 17, 921; Annalen, 1885, 229, 295); the product usually requires more extensive purification than that obtained by the Grignard reaction.

Very few heterocyclic compounds, with the phosphorus atom as a member of the ring, have been prepared. When, however, phenyl-dichlorophosphine is treated with the di-Grignard reagent obtained from pentamethylene dibromide, phenyl-1:5-pentamethylenephosphine (I) is obtained; the tetramethylene compound is similarly prepared (Grüttner and Wiernik, Ber. 1915, 48, 1473; Grüttner and Krause, *ibid.*

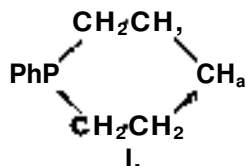

1916, 49, 437). The only other heterocyclic type of unambiguous structure is represented by the tetrahydro-1-josphospholinium salts (*v. infra*).

**Addition Products of the Tertiary Phosphines.**—Tertiary phosphines very readily combine with

many reagents; thus they unite with oxygen, sulphur, and selenium to give phosphine oxides,  $R_3PO$ , sulphides,  $R_3PS$ , and selenides,  $R_3PSe$ , respectively, which are usually highly crystalline compounds, particularly in the triaryl series. They also combine with chlorine and bromine to form  $R_3PCl_2$  and  $R_3PBr_2$ ; combination with iodine is less ready. These halogen derivatives on hydrolysis may give the dihydroxide,  $R_3P(OH)_2$ , or the esqui-cqmpound,



or may form the oxide,  $R_3PO$ , dependent upon the relative stability imposed by the nature of the groups R. After the publication of N. V. Sidgwick's "Electronic Theory of Valency" (Oxford, 1929), the above oxides, sulphides, and selenides were generally accepted as derivatives of 4-covalent phosphorus, of structure  $R_3P \rightarrow O$ ,  $R_3P \rightarrow S$ ,  $R_3P \rightarrow Se$ . More recent evidence from bond lengths (Phillips, Hunter, and Sutton, J.C.S. 1945, 38) indicates that these compounds may, however, be derivatives of 5-covalent phosphorus, *e.g.*,  $R_3P=O$ , or possibly resonance hybrids between the two forms. Until further evidence is available, their structure must remain *sub judice*. For the probable structure of the tertiary phosphine dihalides and dihydroxides and of the intermediate hydroxy-halides, see Mann, "Some Aspects of the Organic Chemistry of Phosphorus and Arsenic" (J.C.S. 1945, 65).

The bonding structure of many other addition products remains similarly uncertain. The deep-red crystalline addition products,  $R_3PCS_2$ , which many tertiary phosphines give with carbon disulphide, have been formulated as (Ha) by Hantzsch and Hibbert (Ber. 1907, 40, 1508) and as (116) by Davies (J.G.S. 1935, 1786).

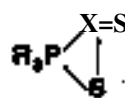

ILz.

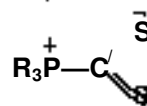

116.

The phosphine-imines and -azines which Staudinger and Meyer (Helv. Chim. Acta, 1919, 2, 612) obtained by the action of, *e.g.*, triphenylphosphine on phenylazide and diphenyldiazomethane respectively, were formulated by these authors as  $Ph_3P:NPh$  and  $Ph_3P:N:N:CPh_2$ , but their structure may be  $Ph_3P \rightarrow NPh$  and  $Ph_3P \rightarrow NN:CPh_2$ . The azines on heating lost nitrogen, and Staudinger and Meyer formulated the product as  $Ph_3P=CPh_2$ , but again their structure may be  $Ph_3P \rightarrow CPh_2$ . Similarly the phosphinimines which Mann and Chaplin (J.C.S. 1937, 527) prepared by the action of tertiary phosphines on Chloramine-T

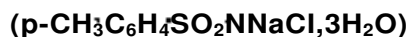

may have the structure  $R_3P \rightarrow NSO_2C_6H_4CH_3$  or  $R_3P \rightarrow NSO_2C_6H_4CH_3$ .

**Phosphonium Salts.**—Trialkyl- and triarylphosphines readily combine with alkyl iodides to form the corresponding phosphonium salts,  $R_4PI$ . These are usually crystalline, stable, water-soluble compounds. Tetra-aryl phosphonium salts cannot be prepared in this way;

they are obtained (i) by the action of, e.g., phenylmagnesium bromide on triphenylphosphine, followed by treatment with oxygen (Dofconov and Medox, Ber, 1928, 61 [B], 907); (ii) by the action of bromobenzene on triphenylphosphine in the presence of aluminium chloride (Chatt and Mann, J.C.S. 1940, 1192).

The phosphonium halides, when treated in aqueous solution with silver oxide, give the corresponding hydroxides,  $\text{R}_3\text{P}^+\text{OH}^-$ , which are strongly basic solids, readily absorbing water and carbon dioxide from the air. Their mode of thermal decomposition differs fundamentally from that of the corresponding ammonium hydroxides; e.g., tetra-ethylammonium hydroxide gives triethylamine, ethylene, and water, whereas the phosphonium analogue gives triethylphosphine oxide and ethane. (For a discussion of the probable mechanism, see Ingold, Chem. Soc. Ann. Rep. 1930, 27, 143.)

**Metallic Derivatives.**—The tertiary phosphines combine with many metallic salts, particularly with the halides of the heavier metals. The products are of various types:

(i) The trialkylphosphines combine with aurous halides, giving compounds of type  $\text{R}_3\text{P} \cdot \text{AuCl}$ , some of which have great stability and can be distilled unchanged; when treated with halogens they form the corresponding auric compounds,  $\text{R}_3\text{P} \rightarrow \text{AuCl}_3$ ,  $\text{R}_3\text{P} \rightarrow \text{AuClBr}_2$ , etc. In both types of compound the 4-covalent phosphorus atom is tetrahedral; the 2-covalent aurous atom has a linear, and the 4-covalent auric atom a planar, configuration (Mann, Purdie, and Wells, J.C.S. 1837, 1828; Mann and Purdie, *ibid.* 1940, 1235; Perutz and Weisz, *ibid.* 1946, 438).

(ii) The trialkylphosphines combine with platinumous chloride to form two isomeric derivatives,  $\{\text{R}_3\text{P}\}_2\text{PtCl}_2$ , which undoubtedly have the cis- and (trans)-planar configuration. Palladium chloride gives only one such derivative,  $\{\text{R}_3\text{P}\}_2\text{PdCl}_2$ , which probably has the more stable trans-configuration; certain of these palladium derivatives are also so stable that they can be distilled unchanged. These platinum and palladium compounds add on a further molecule of halogen to form less stable derivatives, e.g.,  $\{\text{R}_3\text{P}\}_2\text{PdCl}_4$ , in which the metal has undoubtedly the octahedral configuration.

The planar  $\{\text{R}_3\text{P}\}_2\text{PdCl}_2$  will unite with a second molecule of palladium chloride to give a planar bridged dipalladium derivative of structure (III) (Mann *et al.*, *ibid.* 1936, 873; 1938, 702; 1949, 2086; **1089, 1622**). Cadmium and mercury bromides and iodides also give additive

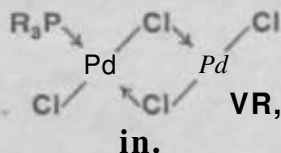

compounds of type  $\{\text{R}_3\text{P}\}_2\text{CdBr}_2$  and  $\{\text{R}_3\text{P}\}_2\text{HgI}_2$ , in which, however, the metallic atom has now the tetrahedral configuration. Both the cadmium and the mercury compounds also unite with one and even two further molecules of the metallic halide to form bridged compounds of type (III); these compounds,

unlike the palladium analogues, are clearly non-planar, as each constituent metallic atom has the tetrahedral configuration (Mann *et al.*, *ibid.* 1940, 1209, 1230).

(iii) Trialkylphosphines also unite readily with cuprous and argentous iodides to give compounds  $[\text{R}_3\text{P}, \text{CuI}]_4$  and  $[\text{R}_3\text{P}, \text{AgI}]_4$ . The structure of these compounds, which contain tetrahedral 4-covalent phosphorus, cuprous and silver atoms, and 3-covalent iodine atoms, has been elucidated by X-ray analysis (Mann, Purdie, and Wells, *ibid.* 1936, 1503; 1937, 1828); for diagram of structure, see CO-ORDINATION COMPOUNDS, Vol. III, 331.

#### STEREOCHEMISTRY.

The structure of certain of the above metallic compounds shows that the 4-covalent phosphorus atom has a tetrahedral disposition. Suitable non-metallic derivatives of 4-covalent phosphorus should therefore be susceptible to optical resolution. This has been realised experimentally for three classes of compounds:

(i) **Phosphine Oxides.**—Meisenheimer *et al.* (Ber. 1911, 44, 356; Annalen, 1926, 449, 224) have resolved phenylmethylphosphine oxide,  $\text{PhMeEtPO}$ ,  $[\alpha]_D^{20} +38^\circ$  in aqueous solution, and phenylbenzylmethylphosphine oxide,  $\text{Ph}(\text{PhCH}_2)\text{MePO}$ ,  $[\alpha]_D^{20} +162^\circ$  in aqueous solution.

(ii) **Phosphite Sulphides.**—Davies and Mann (J.C.S. 1044, 276) resolved phenyl-p-(carboxymethoxy)phenyl-n-butylphosphine sulphide,  $\text{Ph}(\text{C}_6\text{H}_4-\text{OCH}_2\text{CO}_2\text{C}_4\text{H}_9)_2\text{PS}$ ,  $[\alpha]_D^{20} +9.6^\circ$ ,  $-9.7^\circ$  in benzene solution.

(iii) **Phosphonium Halts.**—Hollman and Mann (*ibid.* 1447, 1634) resolved 2-phenyl-2-p-hydroxyphenyl-1:2:3:4-tetrahydro-2-morpholinium bromide (IV),  $[\alpha]_D^{20} +32.9^\circ$  in alcoholic solution, which possesses great chemical stability, to

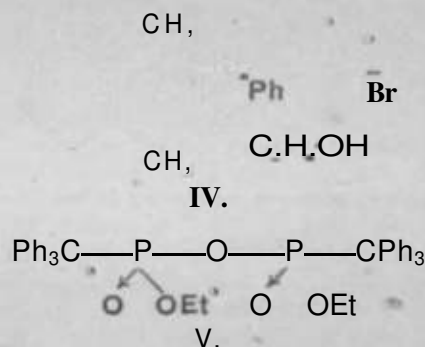

which its optical stability is considered to be due. Fruitless attempts by earlier workers to resolve phosphonium salts were performed with compounds having at least one alkyl group joined to the phosphorus atom; a "dissociation-equilibrium" of the type  $\text{R}_3\text{P}^+\text{Br}^- \rightleftharpoons \text{R}_3\text{P} + \text{RBr}$ , could thus occur in solution and would cause very rapid racemization. Finally, Hatt (*ibid.* 1933, 776) separated ethyl triphenylmethylphosphonate (V) into two forms, m.p. 222–223° and 228–231°, one of which must be the racemic and the other the meso-form. Both forms on hydrolysis gave the same acid, which owing to resonance could not exist in two such forms.

It should be added that the above resolutions confirm but do not prove the tetrahedral disposition, of the 4-covalent phosphorus atom.

F. G. M.

**PHOTOCHEMISTRY.** This subject comprises the study of the chemical effects produced by electromagnetic radiation (visible and ultra-violet light and the near infra-red) of wave-lengths within the range 10,000 to 1,000 Å.

**Units and the Quantum Theory.**—According to the electromagnetic theory, light may be regarded as composed of waves, characterised by their wave-length or by their frequency. Monochromatic light is light of one wave-length, or, more accurately, confined to a narrow range of wave-lengths. The frequency  $\nu$  of a light wave is the number of oscillations per second, and its units are sec.<sup>-1</sup>. Alternatively the frequency can be expressed as the wave-number,  $\sigma$ , or the number of waves, per centimetre. We then have the relation  $\sigma = \nu/c$  cm.<sup>-1</sup>, where  $c$  is the velocity of light =  $2.99780 \times 10^{10}$  cm. per sec. *in vacuo*. The wave-length  $\lambda$  in cm. is the reciprocal of the wave-number. It is usually expressed in Angstrom units, Å, of magnitude  $10^{-8}$  cm., and sometimes in millimicrons, m $\mu$ , which are  $10^{-7}$  cm. or 10 Å. The velocity of light in material media is less than that *in vacuo* and varies with the frequency, being equal to  $c$  divided by the refractive index of the substance. The wave-number and wave-length of light actually traversing a material are therefore dependent on the refractive indices, but in recording data on light absorption and photochemistry these quantities are always referred to light moving *in vacuo*.

When light is emitted or absorbed by matter its behaviour is expressed by quantum theory. Atoms or molecules give out or take up light only in energy steps called quanta; the magnitude of a quantum being proportional to the frequency by the relation: Energy of quantum (erg's) =  $h\nu$  where  $h$  is called Planck's constant and has the approximate value of  $6.62 \times 10^{-27}$  erg-sec. By measuring, therefore, the energy

per second conveyed by a beam of nearly monochromatic light which is absorbed by some material we can estimate the number of quanta per second, and since each absorbing molecule takes up one quantum this is equal to the number of molecules "physically activated" per second. An intense light beam of the dimensions used in a laboratory photochemical experiment may have about  $10^{16}$  quanta per second, and this may be absorbed by about  $10^{21}$  molecules. Since the "life" of an "activated" molecule is a very small fraction of a second we see that at any instant the concentration of "activated" molecules is exceedingly small, and also that about  $10^6$  seconds, or 30 hours, are required to allow every molecule to absorb a quantum under the conditions given above, which represent an average of what is encountered in practice.

Chemists usually prefer to work in units of gram-molecules, or moles, instead of single molecules. 1 gram-molecule =  $6.02 \times 10^{23}$  molecules, =  $N$ . A gram-molecular quantum, or JV single quanta, sometimes called an einstein, represents the quantity of radiant energy necessary to endow one molecule of matter with one quantum per molecule. It may be expressed in ergs, though more usually as kilogram-calories, and its magnitude is given by the equation:  $286,000/(\text{wave-length in Å}) = \text{kilogram-calories}$ .

Physicists often use another energy unit called the electron-volt, which equals the energy an electron obtains when accelerated through a potential difference of one volt. By the relations  $E = h\nu = hc/\lambda = hc\sigma = eV$  where  $E$  = energy,  $e$  = electronic charge, and  $V$  = potential difference in volts, we can derive six equivalent ways of expressing energy absorbed by a molecule from radiation, all of which are in use in photochemical theory. These are as kilogram-calories per gram-molecule, ergs per molecule, frequency, wave-length, wave-number, and electron-volts. The corresponding magnitudes of these quantities for different radiations are shown by Table I.

TABLE I.

Wave-length, Å.	Wave-number, cm. <sup>-1</sup> .	Frequency, sec. <sup>-1</sup> .	Kg.-cal. per g.-mol.	Ergs per molecule.	Electron-volts.
10,000	10,000	$3 \times 10^{14}$	28.6	$1.98 \times 10^{-12}$	1.234
(near infra-red)	14,285	$4.29 \times 10^{14}$	40.7	$2.82 \times 10^{-12}$	1.76
7,000	17,240	$5.17 \times 10^{14}$	49.4	$3.42 \times 10^{-12}$	2.13
(deep red)	19,230	$5.77 \times 10^{14}$	55.1	$3.8 \times 10^{-12}$	2.37
5,800	21,740	$6.62 \times 10^{14}$	62.3	$4.3 \times 10^{-12}$	2.68
(yellow)	25,000	$7.5 \times 10^{14}$	71.5	$4.95 \times 10^{-12}$	3.09
5,200	33,333	$10^{15}$	95.3	$6.6 \times 10^{-12}$	4.11
(green)	50,000	$1.5 \times 10^{15}$	143.0	$9.9 \times 10^{-12}$	6.17
4,600	100,000	$3 \times 10^{15}$	286.0	$19.8 \times 10^{-12}$	12.34
(blue)					
4,000					
(violet limit of visible spectrum)					
3,000					
(near ultra-violet)					
2,000					
(ultra-violet)					
1,000					
(far ultra-violet)					

It may be noted from this Table that the kilocalories received per gram-molecule from radiation between 10,000 and 1,000 A. varies from 28.6 to 286. These magnitudes are comparable with, or greater than, chemical heats of formation; *eg.* the heat of formation of hydrogen chloride from molecular hydrogen and chlorine is 22 kg.-cal., and from the elements in the atomic form, 100 kg.-cal. The long-wave limit of photochemical activity is set by the fact that quanta of infra-red radiation are small and unequal to the bringing about of chemical change. The absorption of infra-red also affects molecules in a different way from the shorter wave-lengths of Table I. Through the action of infra-red radiation molecules are caused to vibrate and rotate, while the absorption of quanta of visible or ultra-violet light usually alters the chemical linking of molecules by energising the electrons associated with the links. At wave-lengths shorter than 1,000 A., in the X-ray region, radiation affects electrons lying deeper down in the atoms composing the molecule, and so does not directly disturb the outer "valency" electrons. Chemical changes caused by these rays are of a secondary origin and are not usually included in the subject of photochemistry. These considerations defining the range of Table I are reinforced by practical limitations. For wave-lengths shorter than 1,000 A. no materials are transparent enough for the construction of apparatus, and even up to 1900 A. atmospheric oxygen acts as an absorber, preventing the radiation passing from light source to the photochemical cell.

**Light Sources.**—The choice of light source for photochemical purposes depends on the wave-length region desired, the photosensitivity of the reaction, and whether the experiments are to be merely qualitative or accurately quantitative. The features of certain light sources are given below.

The sun provides very intense visible light, especially when condensed with a mirror or lens, but it is scarcely suitable for quantitative work.

The electric arc (best with cored carbons) is also a brilliant light source for the visible, but shares with the sun the defect of variations in intensity. For the visible region, where a light source giving a continuous spectrum is required, tungsten lamps are best. For use with filters, high-wattage filament lamps (projection type) or Pointolite lamps are employed, while ribbon filament lamps are necessary for work with a monochromator. When light in the blue end of the spectrum is desired it may be necessary to over-run the filaments to secure sufficiently high intensities. A continuous-spectrum light source for the ultra-violet (to 2,000 A.) is found in the hydrogen discharge lamp. This is more commonly used for absorption spectra measurements than for actual photochemical work, as line sources are better for the latter. The older pattern consists of a long tube with a silica end-window, fitted with large aluminium electrodes and containing pure hydrogen at 1-10 mm. pressure. The ultra-violet emission is excited by the application of 2,000-6,000 v. and emerges as a narrow pencil of rays axially. Low-voltage tubes operating on 110 v. a.c. having specially

prepared alkaline-earth oxide coated electrodes, have been developed more recently.

Light sources giving discontinuous spectra are commonly preferred for photochemical work, owing to the high intensities of monochromatic light attainable, and the most important of these is the mercury arc. The usual type is the medium-pressure arc, and consists of a discharge in mercury vapour at pressures varying between one-eighth and 2 atm. Many different designs are available, but all consist of a clear fused-silica tube in which the discharge passes, varying in shape, in the electrodes (whether tungsten or liquid mercury), and in the mode of filling (whether of the sealed or "open" type). The arc is usually 5-10 cm. long in a tube of 1-2 cm. diameter, carrying 3-4 amp. The lamps are operated on d.c. or a.c., according to the design. The light output depends on three variables, the arc current, the arc voltage, and the pressure of the mercury vapour, the latter being fixed by the steady temperature (300-400°C.) attained by the lamp under the conditions of cooling employed. Fixing two of these variables also fixes the third; consequently a constant current and voltage can be maintained only by control of the cooling. Most lamps are designed for operation in free air; enclosure in a box or subjection to a current of air will therefore modify their light output at fixed voltage. The light output is greatest with high voltage and low current, corresponding to high pressures and operating temperatures. Under these conditions the life of the lamp through loss of transparency of the tube is shortened, and in practice a balance between high output and long tube life is chosen. By decreasing the tube diameter the brightness per unit area of the source is increased. For use with monochromators a high intrinsic brightness is very desirable, and capillary arcs (2 mm. diameter) have been designed for this purpose. Their life is short, but new ones may be easily constructed for each experiment. Table II lists the chief emission lines of the mercury arc, and gives average values for the number of einsteins obtainable for photochemical purposes.

TABLE II.

*Nhv* per sq. cm. per sec. available from mercury lamps taking 4 amp. at 130 v. across arc; either at working distance of 3-5 cm. from a medium-pressure arc, or at slit of a 3-5 monochromator with capillary arc.

Wave-length, A.	<i>Nhv</i> per sq. cm. per sec.
57701 Yellow . . . . .	25X10 <sup>-8</sup>
5790/ . . . . .	
5401 Green . . . . .	18x10 <sup>-8</sup>
4358 Blue . . . . .	13x10 <sup>-8</sup>
4046 Violet . . . . .	6x10 <sup>-8</sup>
3660 <sup>^</sup> . . . . .	18X10 <sup>-8</sup>
3130 . . . . .	10x 10 <sup>-8</sup>
3021 } Ultra-violet . . . . .	5x10 <sup>-8</sup>
2804 } . . . . .	1.8X10 <sup>-8</sup>
2654 } . . . . .	2.2* 10 <sup>-8</sup>
2537 } . . . . .	2x10 <sup>-8</sup>

We may calculate from this Table, for example, that a 3-hour exposure of a cell of 10 sq. cm. area, distant 3.5 cm. from the lamp, to the wave-length 3,130 Å. (supposedly isolated) will "physically activate"  $10^{-2}$  g.-znol., the light being assumed to be completely absorbed in the cell. Another type of mercury arc is designed to operate at higher pressures (up to 80 atm.); these are of short life (about 50 hours), but the light is of an intrinsic brilliance one-fifth that of the sun. The mercury lines are broadened and those of shorter wave-length reduced in intensity by resonance absorption. An entirely different type of mercury lamp contains about 5 mm. of helium or neon, and operates at ordinary temperature. About 10% of the electrical energy consumed, and about 90% of the energy radiated as light, appears at the wave-length of the mercury resonance line 2,537 Å. This lamp affords the most efficient means of obtaining this wave-length, but its intrinsic intensity is not high.

Radiation in the wave-length range 2,300-1,400 Å. of intensities about  $10^{-10}$   $Nh\nu$  per sq. mm. per sec. is obtainable from condensed sparks between electrodes of cadmium, zinc, or aluminium at a power consumption of 1,000 w. Still shorter wave-lengths down to 1,050 Å. are produced by special gas-discharge lamps containing xenon, krypton, or argon.

Cells.—Cells for reaction mixtures or filters are usually constructed of glass for work in the visible region and of clear fused silica for work to 2,000 Å. "Perspex" may be used for the near ultra-violet region. Beyond 2,000 Å. crystal quartz transmits to 1,800 Å., selected fluorite to 1,350 Å., and lithium fluoride to 1,000 Å. in thicknesses of 1 mm.

Experimental Arrangements.—For non-quantitative preparative work, photo-active systems may be simply exposed to sunlight or intense arc or mercury lamp light, with or without a light filter. A suitable straight-pattern mercury lamp may be concentrically surrounded by a cooling jacket containing a circulated filter liquid and again by an annular tube for the reaction mixture. Where precise measurements are necessary the problem becomes more complicated and experimental arrangements more diverse, as many factors are involved. The reaction mixture is then contained in a cell with plane faces back and front, on to which is directed an approximately parallel uniform beam of intense, nearly monochromatic radiation. With non-uniform non-parallel light beams and cells of other shape the evaluation of the light absorbed may be extremely complicated. The cell size depends on the light beam available and whether the absorption is strong or weak, and other features, such as stirring arrangements or mode of filling, on whether the system to be studied is gaseous or liquid, etc. Several methods are available for rendering the light monochromatic or limiting it to a narrow wave-length range. The simplest is by employing a light filter. Used with a continuous source this isolates a band of wave-lengths of some width; with line sources such as the mercury lamp a filter effects a closer degree of monochromatisation. Filters need to be carefully chosen to suit the spectral characteristics of the sources of

light; they should remove the infra-red in addition to other unwanted radiation, be reasonably stable to illumination, and transmit a high proportion of the wave-lengths required within a narrow range. For visible light, coloured glasses and dyed gelatine-film filters are available, while liquid filters may be used both for visible and ultra-violet work. Solutions of suitable strengths and thicknesses of copper sulphate, chloride, or nitrate, or of ammoniacal copper sulphate, are valuable for removing infra-red and long-wave visible light up to any point in the blue. Combined with solutions of dichromate to remove light of shorter wave-lengths than the yellow, or chromate for light shorter than the green, or strong sodium nitrite solution to remove light shorter than the blue, a wide range of visible transmissions can be realised. Other useful filters are iodine in carbon tetrachloride to transmit the violet, nickel-oxide glass for the mercury line 3,660 Å., nickel-cobalt solutions (360 g. of  $\text{NiSO}_4 \cdot 6\text{H}_2\text{O}$  and 100 g. of  $\text{CoSO}_4 \cdot 6\text{H}_2\text{O}$ , very free from iron, made up to 1 litre with water; 4 cm.) for removing the visible and transmitting the ultra-violet 3,300-3,000 Å., gaseous chlorine for transmitting 2,800-2,300 Å. while removing the rest of the ultra-violet, and the following for cutting off shorter wave-lengths: 1% ferric alum in 2N. sulphuric acid (3,800 Å.), 5% potassium hydrogen phthalate (3,000 Å.), potassium iodide (2,600 Å.) and 4N. acetic acid (2,400 Å.). As an alternative to filters in the visible region a device due to Christiansen may be used. It consists of a glass cell filled with glass powder and methyl benzoate and thermostatted. The refractive indices of the glass and the liquid coincide exactly only at one wave-length, which varies with the temperature. A narrow spectral region near the coincidence is transmitted by the cell, adjustable by temperature control, while the remainder of the light is eliminated by scattering. Very short-wave light from sparks is most conveniently treated by "focal isolation," use being made of two crystal quartz condensing lenses and small apertures placed at the points where they bring to a focus the wave-lengths required. For the visible and ultra-violet region to 2,600 Å. an expensive but very satisfactory device is a specially designed high-aperture monochromator. This is constructed of fused silica for ultra-violet work and used in conjunction with a high-brightness capillary mercury arc. The transmissive qualities of silica monochromators begin to fail beyond 2,600 Å., but for work with the mercury line 2,537 Å. they are unnecessary because of the availability of the special mercury lamps, the radiation from which is largely concentrated at this wave-length.

A quantitative photochemical experiment involves the determination of the amount of light of defined wave-length reaching the reaction cell during the time of exposure, the fraction of that radiation actually absorbed by the reactants, and the nature and amount of the chemical change produced. The amount of light reaching the cell is usually determined with a thermopile and galvanometer which has been calibrated in energy units (ergs per sq. cm. per sec.) by means

of a "standard lamp,"\* the emission of this (sub-) standard having been determined at a standards institution by reference to the absolute radiation from a "black body" of known temperature. The thermopile may be of "surface type"; greater accuracy is, however, obtainable by "integrating" the light beam with a movable "linear" thermopile. From the number of ergs impinging as radiation during the exposure on the photochemical cell the number of einsteins or units of  $Nh\nu$  are calculable from the simple quantum relation. To find the number of these units absorbed allowance must be made for light losses by reflection from the cell faces and for light unabsorbed. The fraction of the light absorbed may be determined by placing the thermopile behind the cell, or it can be calculated from the "extinction coefficients" as determined by standard methods of absorption spectroscopy. In the absence of complicating effects, such as the presence of other absorbing materials, or changes of molecular structure or environment with concentration, the fraction of light absorbed from a monochromatic parallel light beam by a thickness of solution  $d$  cm. is  $(1 - 10^{-cd})$  where  $c$  is the molar extinction coefficient and  $c$  the concentration of the absorbing substance in g.-mol. per l. A similar expression holds for gases with the pressure substituted for the concentration. Careful attention must be given to many details in the above determinations; the constancy of the light source, changes in absorption during exposure, the possibility of the formation of other inert absorbing substances, or of precipitates which scatter the light. Conditions are somewhat simplified if the light absorption, is either total or very weak. In the former case, disturbing causes being absent, the number of molecules receiving a quantum is independent of concentration, so that the photo-change is linear with time, while in the latter case the absorption is proportional to the concentration, so that the photo-change follows a "unimolecular" law. There remains the determination of the amount of chemical change produced. For this there are as many methods as there are different photo-reactions; analysis by changes of pressure in gases, changes of titre in solutions, changes of light absorption or electrical conductivity, etc. Estimations may be discontinuous, or flowing systems may be used. Three major difficulties almost always face the experimenter: (a) the absolute amount of chemical change is often very small, perhaps  $10^{-4}$  to  $10^{-5}$  g.-mol. per hour of exposure; (b) the final products are often a complex mixture of difficultly identifiable substances the proportions of which vary with the length of exposure; and (c) the final products are the result of complex secondary reactions which obscure the nature of the primary photo-change. For this reason, in spite of intensive study in certain cases, the mechanisms of few photochemical reactions have been satisfactorily worked out.

Determination of Kinetics.—Incomplete study of a photochemical reaction, measurements as described above are carried out with changes in all the possible variables, namely, light intensity, wave-length, and concentrations or

partial pressures of the reactants over a wide range, together with a study of the effects of suitable additions to the system, such as the artificial introduction of atoms or radicals. These results permit of the formulation of the kinetics of the reaction, i.e., of the mathematical relationship between the reaction rate and the above variables. The next step is to discover, by trial and error, a set of chemical equations which are in agreement with the measured kinetics. As a guide, attention is directed to two considerations. First, the quantum efficiencies of the reaction under various conditions are calculated. These are the ratios of molecules reacted to quanta absorbed, or, what is equivalent, gram-molecules reacted to einsteins absorbed. If every molecule which absorbed a quantum, thereby becoming "physically" activated, simply underwent chemical change into a stable product molecule, the quantum efficiency would be unity. Exceedingly few reactions show such simplicity, and values of quantum efficiencies vary from very small fractions to figures of the order of a million. If the efficiency is fractional it indicates that not all the "physically" activated molecules proceed to permanent chemical reaction; this state of affairs is found with most coloured substances, such\* as dyes, which fade very slowly in light. Efficiencies greater than unity show that "physically" activated molecules bring about the chemical reaction of a greater number of molecules which have not been directly excited by the light; i.e., they set up a "chain mechanism." This they do usually by dissociating into atoms or radicals the high chemical activity of which brings about the reaction "chain." Examples of these types of behaviour are discussed in detail below. The second consideration which is relevant is the nature of the spectrum of the absorbing substance. As explained below, under favourable circumstances it is sometimes possible to discover the *primary* chemical effect produced by the light after "physical" activation of a molecule; with this *primary* change established one can proceed with more confidence to attempt to unravel the *secondary* chemical reactions (of a thermal and non-photochemical character) which are so common a feature in photochemistry. As will appear later, it often turns out that even when the above considerations are fully taken into account the kinetics provide ambiguous answers; more than one set of chemical reactions satisfy them and it may be difficult or impossible to distinguish between two or more plausible "mechanisms."

According to the electronic theory, atoms consist of minute positively charged nuclei round which are grouped the negatively charged electrons. These electrons occupy certain regions of space round the atom, the theoretical subject of wave-mechanics purporting to define these regions in mathematical terms. Only a limited set of different arrangements of the electrons appear to be possible, and the laws of these arrangements, given by "wave-equations," somewhat resemble the laws of vibrations of complex objects such as a bell, which are restricted to certain types of fundamentals and



overtones or harmonics. Each different electronic arrangement of an atom has a different energy; the state of lowest energy is called the "ground state." If radiation falls on a system consisting of atoms in their "ground states," one of two possibilities may occur. The system may be transparent to the radiation; here the electromagnetic waves temporarily distort the electronic arrangements as they pass by, but produce no permanent effect on the matter. A reduction occurs in the velocity of the radiation by its interaction with the atoms; this effect being known as *refraction* and *dispersion*, but no chemical change can result. On the other hand, the system may be more or less opaque to the radiation and the atoms may *absorb* it. This occurs when the frequency of the radiation is such that the quantity of energy  $h\nu$  just equals the energy necessary to cause an atom to change from its ground state to a higher state with a different electronic arrangement. The number of atoms so affected equals the number of "quanta" absorbed. Owing to the limited number of states possible for any atom, atomic spectra consist of narrow lines of frequencies given by the above quantum relationship. Such an absorption spectrum is shown by the Fraunhofer dark lines of the solar spectrum.

When these considerations sketched in outline above are extended to molecules additional complications are observed. The laws of the grouping of electrons in molecules are the same as those for atoms, but are more difficult to apply, since a molecule has more than one nucleus within it. When chemical bonding occurs between two atoms, certain electrons (from the outermost electrons of the atoms) are held in common by the two nuclei, while the remaining electrons continue to be associated with one nucleus only. A "single bond" in chemistry corresponds to a pair of electrons held in common by two atomic nuclei, and a "double bond" by two pairs so held. In the latter case the two pairs are not similar, but occupy different regions of space in the bond, one pair being more weakly "bound" than the other. Because of this weak binding, molecules with double bonds absorb at longer wave-lengths than those with single bonds only, and more commonly feature in photochemical reactions. In organic compounds with "conjugated" structures,  $\text{C}=\text{C}-\text{C}=\text{C}$ , having double and single bonds arranged alternately when the molecule is conventionally symbolised by a chemical structure formula (e.g., butadiene or benzene), certain bonding electrons are shared between more than two nuclei, so that the true "structure" cannot be represented adequately by a valency formula. These molecules are of peculiar interest in photochemistry, but the difficulty of understanding the effect of absorption of light is enhanced by their structural peculiarities. It may be stated in general terms, however, that when any molecule absorbs radiation lying roughly in the limits 10,000-1,000 Å. its electronic arrangement is altered. One electron is removed from the position it occupies in the "normal" or "ground" state and is elevated to another position of higher energy within the molecule. The electron so affected is usually one from the

"bonding" or "shared" electrons in the molecule, causing an immediate and profound change in the chemical links holding the molecule together; in certain instances, however,\* the light is taken up by a "non-bonding" electron.

When a molecule has been "physically activated" by light absorption, whereby one of its electrons has been raised to a "higher level," it undergoes in a very short space of time, usually less than  $10^{-8}$  second, one of the fates shown below in Table III.

TABLE III.

1. Deactivation:
  - (a) Spontaneous.
  - (b) By collision.
2. Fluorescence.
3. Chemical reaction by collision?
4. Dissociation into atoms or radicals:
  - (a) Photo-dissociation:
    - (i) Spontaneous,
    - (ii) Induced by collision.
  - (b) Predissociation:
    - (i) Spontaneous,
    - (ii) Induced by collision.

These possibilities are best explained by reference to the "potential-energy curves" of diatomic molecules.

In Fig. 1 the ox axis represents distances between the nuclei of a diatomic molecule, OB being the inter-nuclear distance for the non-vibrating molecules, OY is an energy axis. If one atom is imagined fixed on the OY axis, the other atom may be represented as vibrating along the lines 1,1, 2,2, 3,3, etc., when the molecule has 0, 1, 2, etc., quanta of vibrational energy. (The apparent vibrational energy of the molecule on the 1,1, level, where the molecule is regarded as having zero quanta of vibration, is explained by wave-mechanics as "zero-point energy.") These points may be joined by the "potential-energy" curve ABO. The "compressional" limb BA rises steeply, but the "stretching" limb BO curves away to a horizontal asymptote CH owing to the weakening of the bond forces at high amplitudes of vibration. The height OH represents the energy of dissociation of the normal molecule into two unexcited atoms, since a vibration of infinite amplitude is equivalent to dissociation. At ordinary temperatures the majority of the molecules will be at the 1,1 level, this being their "ground state" as regards vibrational energy (see note above). A small fraction will be on the 2,2 level, and much smaller fractions still on the higher levels. Passage from level 1,1 to level 2,2 corresponds to absorption of a quantum of infra-red radiation while jumps from the 1,1 level to higher levels, requiring higher energy, are very improbable and are therefore associated with exceedingly weak absorption bands.

Above the curve ABC is a similar one DEF representing the vibrations of an excited molecule, i.e., one in which an electron has been excited by receiving a quantum of energy given by the height of E above ox. The magnitude of this quantum corresponds to the absorption of

visible or ultra-violet light. Such a molecule, on dissociation (asymptote FJ), gives one excited and one normal atom, the distance OF being the Recitation energy of the atom. The passage of a molecule from one curve to the other is governed by the Franck-Condon Principle. This states that when the electron is excited by absorbing a quantum of radiation it moves to its new position so rapidly ( $10^{-16}$  second) that the vibrations of the nuclei (period about  $10^{-13}$  second) cannot keep pace. Since almost all the absorbing molecules at ordinary temperatures are practically at point B of Fig. 1, and by the above principle the inter-nuclear distance cannot alter during absorption, the process of

excitation is represented by the vertical line so. A compressed excited molecule results, which at once begins to vibrate (in Fig. 1, along the 4,4 level). This illustrates the important difference between the absorption spectra of atoms and molecules. When the latter absorb light the electronic transition is accompanied by changes of vibrational energy. Changes of rotational energy also occur, but are not represented by the figure. The vertical transition from B to 0 represents the *most probable transition*; transitions to the levels 3,3, 2,2, 5,5, 6,6, etc., of curve DEF, lying just off the vertical line, are also possible with lesser probabilities. The spectrum resulting from these transitions is

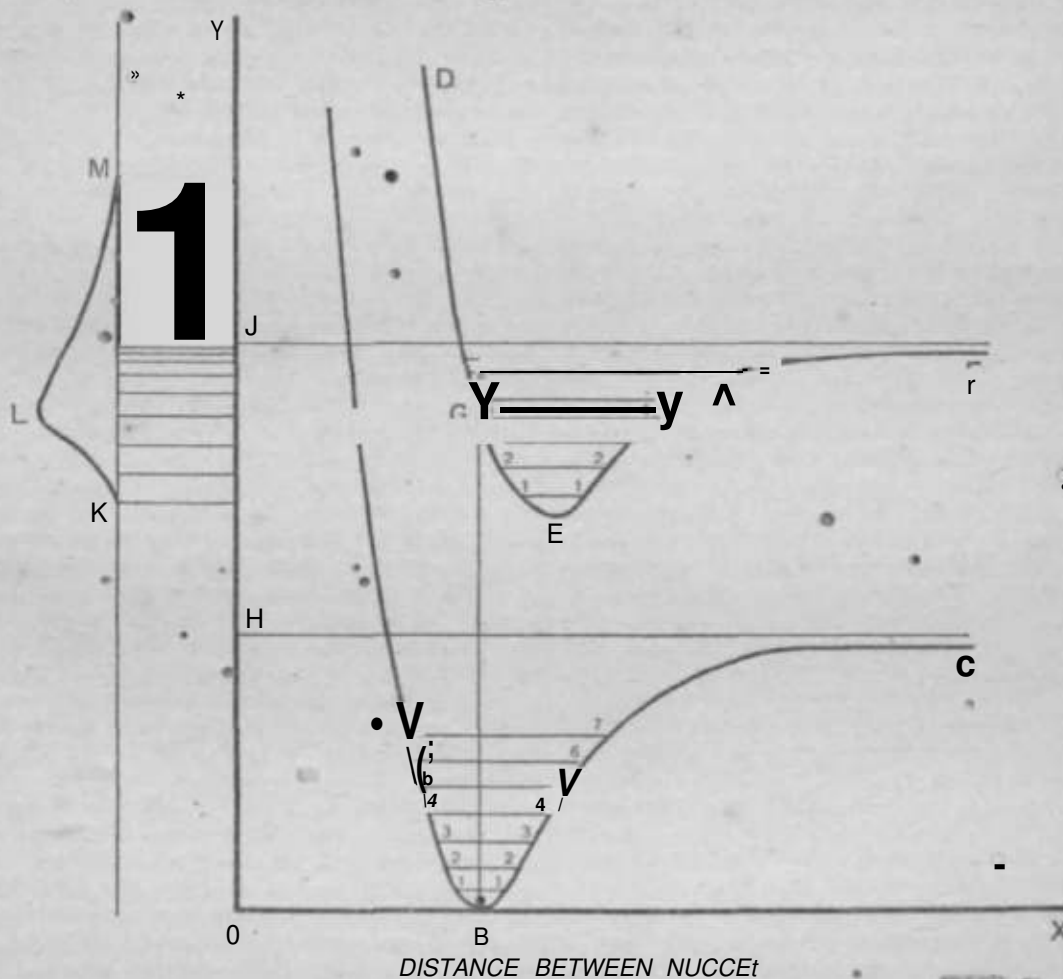

FIG. 1.

shown to the left of the axis OY. AH OY is an energy axis, and quantised energy is proportional to frequency, the absorption spectrum appears on a frequency scale. The spectrum is a series of lines corresponding to jumps from B to the different vibrational levels of curve DEF, which converge to a limit  $j$ . Each "line" is really a bunch of finer lines ("rotational structure") due to simultaneous changes in the quantised rotational energy of the molecule. Absorption of light of frequency beyond  $j$  causes the molecule to dissociate into one normal and one excited atom; since these atoms can separate with any value of (non-quantised) translational energy the spectrum here becomes structureless

or continuous. The curve KLM represents the distribution of the intensity of the absorption. This is most intense at L, corresponding to point G, and falls on both sides, more steeply towards the side of lower frequencies. The features of a "typical" molecule absorption spectrum may thus be summarised: passage from the ground state to an electronically excited state corresponds to a broad region of absorption. This consists of "lines," or better, "partial bands," due to changes of vibrational energy, each "partial band" having a "rotational fine structure" of finer lines, and of a region of continuous absorption at shorter wave-lengths. Absorption in the continuous region "photo-

dissociates " the molecule into atoms (4 (a) (i) of Table III). Absorption in the banded region gives an electronically excited molecule, which may undergo a variety of fates. Its energy is greater than that corresponding to the asymptote OH; *i.e.*, is more than sufficient to dissociate the molecule into two normal atoms. This, however, is possible only when the energy is re-arranged in a suitable collision, and process 4 (a) (ii) of Table III occurs. Collision with another molecule may, however, rob the excited molecule of its energy, degrading it to heat, giving process I (6), or alternatively lead to chemical reaction, process 3 of Table III. It may happen that the electronic structure of the excited molecule is one of unusual stability and insensitivity to collisions; here by the effect of collisions it will come into thermal equilibrium with the system, *i.e.*, lose the high vibrational energy and pass from O to E (Fig. 1). After an interval of about  $10^{-8}$  seconds the molecule may lose its electronic energy by re-radiation; it

stable " or " repulsional " electrons state represented by PR curve DEF at \*- The absorption band corresponding to transitions from *p* (it energies or frequencies below N show the "osnttal " partial band " system with " rotational fine structure." At N or above, however, the excited molecule changes over to curve PR and dissociates into normal atoms after executing a few vibrations. As rotational periods are comparatively long ( $10^{-11}$  second) the molecule may not complete a rotation before this occurs, so that the " rotational fine structure " of the " partial bands " is blurred. The phenomenon of blurred rotational structure, associated with a delay in process of dissociation, is called " pre-lissociation." Fig. 3 illustrates process 4 (*t*>) (i) of Table III; 4 (*b*) (ii), manifesting itself by a blurring dependent on pressure, needs a more complicated diagram with one more upper state for a complete interpretation.'

It would seem from the above considerations that from the appearance of the absorption

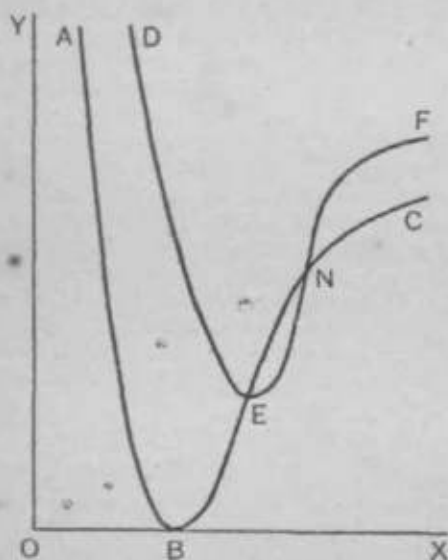

FIG. 2.

drops down a vertical line from E to levels around 6.5 of curve AUC, emitting & fluorescence spectrum mostly of lower frequencies than the absorption spectrum (Stokes' law), as the distances travelled are less than 10<sup>10</sup> cm. (Process 2 of Table III.)

Dimeric diatomic molecule spectra differ from the " typical " one. The spectrum may be wholly continuous, due to point a (and hence L) lying well above the asymptote FJ, or to the upper curve having no minimum and converging to an unstable upper state, *see* curve FR of Fig. 3). Another possibility is shown in Fig. 2. The potential energy curves of the two states cross, so that an excited molecule (curve DEF) can lose its energy by spontaneously passing over to curve ABO at points B or S, reverting to the ground state (with excess vibrational energy quickly lost by collisions). This corresponds to I (6) of Table III. A more complicated picture is shown in Fig. 3. ABC is the ground state, and CEF the electronically excited state reached by the absorption of light. The curve of an " un-

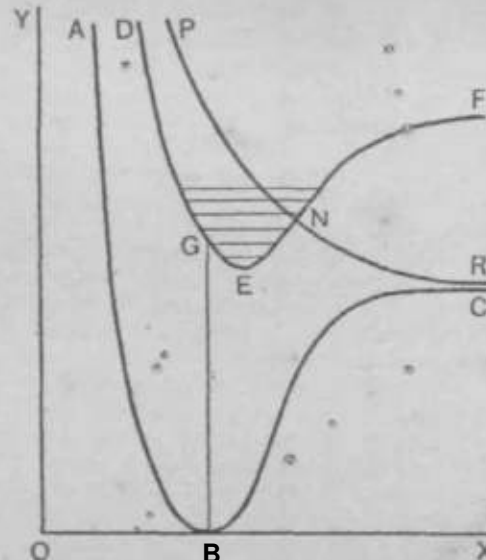

FIG. 3.

spectrum it should be possible to decide on the primary effect of the light on the molecule; whether a relatively stable excited molecule is produced, or whether dissociation, delayed or otherwise, occurs. Unfortunately, matters do not turn out so simply, especially when molecules of greater complexity than diatomic are concerned. Here the potential energy curves become hyper-surfaces in polydimensional space, which intersect in complicated ways and cannot be elucidated in detail. Blurred rotational structure is sometimes observed where quantum-chemical evidence makes the assumption of dissociation impossible; on the other hand, sharp rotational structure is observed in other cases where dissociation does occur, but after an interval so long that the rotational energy of the molecule can impress its quantisation on the spectrum. Continuous spectra may occur without a dissociation process merely because they are formed by the overlapping of thousands of lines of slightly different frequencies. Substances in the liquid or dissolved form always

show absorption spectra with the rotation structure and lyost, if not all, of the vibration structure smeared out owing to the "detuning" of the molecular frequencies due to the variable but powerful electrical interactions between molecules in close proximity to one another. Consequently the information derivable from an examination of the absorption spectrum may be negligible or even deceptive. For certain diatomic molecules in the gaseous state, however, the spectral evidence is clear and decisive; it is fundamental, in fact, for the interpretation of certain photochemical reactions of importance. Examples of these are described below.

It has already been pointed out that the primary effect produced by the light often bears little relation to the final products of photochemical change, owing to, deactivation, thermal chain mechanisms, etc. In most instances, however, the final measured chemical change is proportional to the amount of light absorbed by the photo-active substance in the system. Certain examples nevertheless show a different behaviour, the measured rate being proportional to the *square root* of the light absorbed. The examination of such reactions needs particular care; for example, if the light is moderately strongly absorbed, the amounts of light absorbed vary with depth in the system, and the over-all photochemical rate is not simply the sum of rates calculated as for the more usual case of proportionality to the light intensity. The *equilibrium* relationship always arises from one cause; the production of atoms or radicals directly or indirectly by the light followed by the recombination of the *majority* of these atoms or radicals\* according to a *bimolecular* reaction law. The measured photo-change is then a by-product effect\* arising from the further reactions set up by the *minority* of the atoms or radicals, namely, those which escape recombination. The rates of photo-reactions of this type vary in an important way if *intermittent* light is used; for the same amount of light the rate is faster if the intermittency is rapid than if it is slow. Experiments on this are conducted by interposing the arms of a rotating sector in the light path, by varying the speed of which the intermittency is varied. At high speeds the atoms or radicals, which are constantly being formed by the light, do not have time to recombine appreciably during the dark intervals, and so maintain a relatively high stationary concentration which determines the rate of the measured photo-change. At low speeds the concentration of the atoms or radicals drops to zero during the dark intervals, and this reduces the measured rate. Over a narrow range of intermediate speeds the measured rate changes rapidly from one value to the other. The average period of illumination or of darkness corresponding to this change-over is an approximation to the *half-life* period of the atoms or radicals, *i.e.*, of the time for their concentration to fall to one half. In this way reaction-velocity data are obtainable for an otherwise inaccessible part of the total photo-change.

The effect of *temperature* on a photo-reaction depends very much on its complexity. Reactions which have no "chain mechanism"

usually show almost a zero temperature coefficient. Since light absorption varies very little with temperature this is so whether the overall rate or the quantum efficiency is considered. Where extensive secondary reactions occur, however, the temperature dependence is that of one of the thermal reactions involved and may be high.

**Actinometry.**—Many attempts have been made in the past to utilise selected photo-reactions for the measurement of light intensity and so as standards for comparison with other photo-reactions. It is a good illustration of the general complexity of photo-reactions that few have been successful. A suitable system should have a light absorption unchanged by reaction, be free from objectionable characteristics such as absorption or scattering of light by the products, and have a quantum efficiency independent of wave-length and strictly proportional to the light intensity. No photo-reactions covering the visible spectrum and fulfilling these conditions are available. For the ultra-violet region 4,000-2,000 Å. aqueous solutions of uranyl oxalate with excess oxalic acid are valuable. The mechanism of this reaction is described below. The photo-decomposition of hydrogen iodide over the same wave-length range affords an actinometer suitable for work with gas reactions. At shorter wave-lengths the formation of ozone from oxygen and the decomposition of carbon dioxide may be used. The advantage of an actinometric reaction as a comparison in photochemistry is that, once the actinometer has been calibrated, the elaborations of thermopiles, etc., are avoided and corrections due to light losses in the apparatus by reflection or poor transmission automatically eliminated.

#### SUBDIVISION OF PHOTOCHEMICAL REACTIONS.

**Diatom I c Molecules.**—*Hydrogen* and *nitrogen* scarcely absorb in the commonly agreed wave-length limits of photochemistry, and are therefore unaffected directly by radiation within such limits.

*Oxygen* absorbs strongly below 1,800 Å. and the spectrum indicates that atoms are formed by photodissociation. A weaker absorption spectrum at longer wave-lengths, 2,500-1,900 Å., is detectable with oxygen at high pressure; here atoms are also formed by photodissociation, either spontaneous or induced. The final photo-product obtained is ozone by the reactions

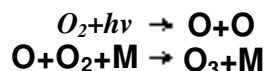

M stands for another molecule of oxygen or for any other suitable molecule present in the system, the intervention of which is required by quantum theory to carry away as translational energy any excess energy during the change. This is expressed commonly as the necessity for a "three-body collision" in elementary reactions where otherwise a single molecule (with strictly quantised internal energies) is produced. The quantum yield of ozone is ideally 2, and this value is reached under most experimental conditions, but smaller efficiencies occur at long wave-lengths, low pressures, and where the

ozone is allowed to accumulate so that a back photo-decomposition becomes serious.

If hydrogen is added to the above system some water is formed at a very low quantum efficiency. The mechanism of this reaction has not yet been solved.

The *hydrogen halides* absorb in the ultra-violet region; hydrogen chloride beyond 2,500 Å., hydrogen bromide beyond 3,300 Å., and hydrogen iodide beyond 3,850 Å. The spectra are continuous, and indicate a process of photo-dissociation into normal atoms, the potential energy curve of the excited states being of the type PB of Fig. 3. When hydrogen chloride gas is exposed to short-wave ultra-violet light very little permanent photo-change is observed, however, owing to the rapid recombination of the dissociation products which occurs both thermally and photochemically (by the absorption of light by the chlorine). In presence of oxygen free chlorine is produced in quantity, evidently owing to the removal of hydrogen atoms as water. Gaseous hydrogen bromide and iodide decompose in ultra-violet radiation with a quantum efficiency of 2, since back reactions are negligible:

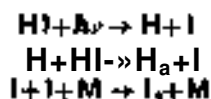

Each hydrogen atom produced reacts with another hydrogen iodide (or bromide) molecule, and the iodine (or bromine) atoms combine to molecules by a "three-body" collision. In presence of oxygen, water is formed, almost certainly through the intermediate formation of the unstable molecule HO<sub>2</sub>.

The *halogens* have spectra and potential energy curves resembling those of Fig. 1, the features of the spectra being a banded system with rotational fine-structure on the long-wave side, converging to a limit, followed by a region of continuous absorption towards the short waves. Other imperfectly investigated absorption regions exist in the further ultra-violet. The approximate limits, etc., of these bands are given in Table IV. The spectral facts vary

TABLE IV.

Halo-gen.	limits of first absorption band, Å.	Convergence of partial bands, Å.	Maximum absorption, Å.	Data on second band system.
Cl <sub>2</sub>	5,400-2,600	4,785	3,400	Beyond 2,000 Å.
Br <sub>2</sub>	6,000-3,300	5,100	4,100	Around 2,250 Å.
I <sub>2</sub>	7,000-4,300	4,995	45,000	3,003 Å* to very short wave-lengths.

clearly indicate that when the halogen molecules absorb light they photodissociate into atoms; beyond the convergence limits this occurs spontaneously, as explained by Fig. 1, and in the banded region the dissociation is brought about by collisions (process 1 (6) of

Table III). Both in the gaseous or in the dissolved state of the halogen, illumination must cause dissociation with a quantum efficiency of two atoms per quantum; these atoms either speedily recombine to molecules, or, if some other reactive substance is present, take part in secondary changes of ordinary "thermal" reaction character. These subsequent reactions prove to be of a very complicated and elusive nature, and in spite of a vast amount of work on photochemical "halogenations" much still remains obscure. Some of the more salient and settled facts are discussed below.

The photo-reactions of the halogens with hydrogen have proved of exceptional intricacy and interest. Following the production of halogen atoms by the light, the reactions below are possibilities (X=halogen atom):

TABLE V.

Reaction.	Activation energy, kg.-cal. per g.-mol.		
	Cl.	Br.	I.
1. X+H <sub>2</sub> → HX+H	6	18	35
2. H+X <sub>2</sub> → HX+X	0	0	0
3. X+X+M → X <sub>2</sub> +M	0	0	0
4. H+X+M → HX+M	0	0	0
5. H+H+M → H <sub>2</sub> +M	0	0	0
6. X+wall → JX <sub>2</sub>	0	0	0
7. H+waU → JH <sub>2</sub>	0	0	0

Reaction-velocity theory shows that the rate of a thermal reaction such as (1) above equals  $10^{14} e^{-E/RT}$  g.-mol. per c.c. per sec, where  $E$  is "activation energy" of the reaction,  $R$  the gas constant, and  $T$  the absolute temperature. The absolute values of the activation energies of reaction (1) are all-important in determining the different features of the photo-reactions of hydrogen with the three halogens. In the case of iodine the exponential factor is so small that the rate of (1) is negligible, explaining the experimental fact that no photo-combination of hydrogen with iodine is observed. With bromine, reaction (1) is extremely slow at ordinary temperatures, but is faster at about 180°c., and only here is the photo-formation of hydrogen bromide easily measurable. The kinetics of the reaction are:

$$d[\text{HBr}]/dt = \{k_1 \sqrt{I} [\text{H}_2]\} / \{1 + k_2 [\text{HBr}]/[\text{Br}_2]\}$$

where  $I$  is the absorbed light intensity. This equation can be shown to be in perfect accord with the following assumptions:

- Dissociation of bromine molecules by light (proportional to  $I$ );
- Recombination of most of the atoms to bromine molecules (reaction (3), Table V);
- A small fraction of the bromine atoms reacting as (1), Table V;
- The hydrogen atoms disappearing by two competing processes, (2) Table V, and  $\text{H} + \text{HBr} \rightarrow \text{H}_2 + \text{Br}$ . (This gives the term  $[\text{HBr}]/[\text{Br}_2]$  in the denominator.)

The mechanism of the reaction is thus very satisfactorily interpreted, and is found to agree with measurements on the thermal combination of Hydrogen and bromine. Since this reaction obeys the  $\sqrt{I}$  law the half-life of the bromine atoms can be determined by rotating sector experiments as described above.

The photochemical hydrogen-chlorine reaction has been the subject of more investigations than any other photo-reaction, and no system has proved more tantalising and intricate. This in large part is due to the enormous influence exerted on the measurements by minute amounts of various impurities. As a result much of the experimental work has proved in vain, many investigators having been led unfortunatly into the-wisp chases. Though many obscurities still remain associated with this reaction, it is now possible to provide a mechanism for its chief features and to understand the general nature of its complexities. Difficulties arise at the very outset of an experimental method. Unless the apparatus is subjected to a treatment with hot chlorine before use, traces of ammonia present as salts or albumenoid substances cause lengthy "induction periods" during which the photo-change is apparently suspended until the nitrogen chlorides formed are decomposed by the light. Even distilled water contains enough nitrogeous material to produce an induction period, and inhibition due to tap-lubricants and drying agents have proved pit-falls for unwary investigators. Oxygen, an impurity difficult to remove, present at one part in a thousand or so, exerts such an effect on the photochemical rate as to make this inversely proportional to its concentration. Modern technique purifies the chlorine by liquefaction and low-temperature fractionation, and the photo-reaction is followed by measurements of the pressure of the hydrogen after condensation of the chlorine and hydrochloric acid by liquid air, but uncertainties due to the unwanted introduction of inhibitors during the manipulations are always present.

Under conditions of extreme purification, quantum efficiencies of  $10^5$ - $10^6$  have been observed. The initial photodissociation of chlorine molecules by light must therefore be followed by very long thermal reaction chains. It is the effect of impurities and vessel walls on these "chains" which produces the extreme sensitivity of the reaction to small and often difficultly controllable differences between different experiments, since the "stopping" of a "chain" at an early stage may reduce the reaction rate by a factor of many thousands. The chain mechanism now rests on sound theoretical considerations. It will be seen in Table V that reaction (1) for chlorine has a low activation energy, so that an appreciable fraction of collisions at the ordinary temperature between chlorine atoms and hydrogen molecules yields hydrogen chloride and a hydrogen atom (estimated about 1 in  $10^5$ ). The hydrogen atom can attack an unactivated chloride molecule (reaction (2)) to give hydrogen chloride and another chlorine atom, which is then free to react as (1). This self-repeating pair of reactions would lead to an infinite quantum efficiency if no "chain-ending" processes were present. To the variety,

mode of action, and efficiency of "chain-enders" the reaction owes its complicated kinetics.

No single kinetic expression has been found adequate to summarise experimental data obtained under all conditions. The alteration of one variable is often found to effect a complete change in the whole kinetics. For oxygen-free mixtures, in small vessels and with hydrogen in excess,  $d[\text{HCl}]/dt = k[\text{H}_2]$ , the rate being proportional to the hydrogen and the light absorbed, and independent of the chlorine concentration; the rate is also slower the greater the surface/volume ratio of the vessel. The chains evidently end by reaction at the walls:  $\text{Cl} + \text{wall} \rightarrow \text{JCl}_2$ . With excess of chlorine the rate expression involves the square root of the light absorbed and an inverse dependence on the chlorine:

$$d[\text{HCl}]/dt = k\sqrt{I}[\text{H}_2]/[\text{Cl}_2]$$

The chief chain-ending process must here be either  $\text{Cl} + \text{Cl}_2 \rightarrow \text{Cl}_3$ ;  $2\text{Cl}_3 \rightarrow 3\text{Cl}_2$  or  $\text{Cl} + \text{Cl} + \text{Cl}_2 \rightarrow 2\text{Cl}_a$  (equation 3, Table V). These alternatives cannot be distinguished in any simple way.

In presence of oxygen the kinetics are radically different, and simultaneously with the hydrogen chloride formation some of the oxygen is consumed to form water. Such an induced reaction is called "photosensitisation." The following reactions have to be taken into account to explain the facts:

8.  $\text{H} + \text{O}_2 + \text{M} \rightarrow \text{HO}_2 + \text{M}$  (M = any molecule acting as third body.)
9.  $\text{Cl} + \text{O}_2 + \text{M} \rightarrow \text{ClO} + \text{M}$ .
10.  $\text{HO}_2 + \text{H}_2 \rightarrow \text{H}_2\text{O} + \text{OH}$ .
11.  $\text{HO}_2 + \text{Cl}_2 \rightarrow \text{HCl} + \text{CrO}_2$ .
12.  $\text{HO}_2 + \text{HCl} \rightarrow \text{H}_2\text{O} + \text{ClO}$ .
13.  $\text{H} + \text{H}_2 + \text{O}_2 \rightarrow \text{H}_2\text{O} + \text{OH}$ .
14.  $\text{H} + \text{HCl} + \text{O}_2 \rightarrow \text{H}_2\text{O} + \text{ClO}$ .

Reactions (13) and (14) are alternatives to (10) and (12). Under ordinary pressure conditions the kinetics are:

$$d[\text{HCl}]/dt = k_1[\text{H}_2][\text{Cl}_2] + k_2[\text{O}_2] / ([\text{O}_2][\text{H}_2] + k_3[\text{Cl}_2])$$

and quantum efficiency of water formation

$$= 2[\text{H}_a] / ([\text{H}_a] + 3[\text{Cl}])$$

These expressions are deducible using equations (8-14) above, although the  $\text{Cl}_a$  cannot be distinguished. The following points should be noted. The assumption of the radical  $\text{HO}_a$  rests for its justification on the effect of oxygen on the photo-decomposition of hydrogen iodide; experimental facts here indicate that this radical is comparatively stable and has a long life. No hypotheses about the fate of the OH radical in equation (10) or (13) can be tested. As the proportion of oxygen in the mixture is increased the ratio  $\text{HCl}/\text{H}_2\text{O}$  formed decreases from a very high value to about 1-5. The fact that the limit is not zero indicates that reaction (8) is faster than (9). Lastly, reactions (12) or (14) take account of the supposed inhibiting effect of hydrogen chloride on the reaction, an effect which in any case is small.

The photochemical combination of chlorine

with deuterium is about one-tenth as fast as the corresponding reaction with hydrogen, owing to the slightly larger heat of activation of the change corresponding to (1) of Table V.

The complexities associated with the presence of chlorine atoms, other atoms and radicals, and self-repeating chains ending in a variety of ways, are also found in other photochemical chlorinations. The features of these differ in detail, however, and in a few instances only have satisfactory mechanisms been proposed.

The reaction of *carbon monoxide* with chlorine obeys the kinetics:



This is explicable by a suitable combination of the following reactions:

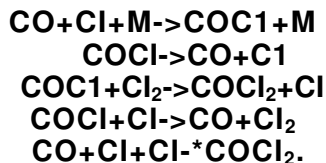

The observed high quantum efficiency arises from the production of new chlorine atoms in the above thermal processes.

In presence of oxygen the photosensitised formation of carbon dioxide is observed. The intermediate radical COCl appears to be competed for by Cl<sub>2</sub> or O<sub>2</sub>; with the latter molecule the probable reactions are:

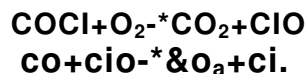

Though much careful work has been carried out on this reaction its details have not been completely elucidated; it seems reasonably certain, however, that the radical COCl plays an essential part.

Photochemical chlorinations of hydrocarbons fall into two types, substitution and addition. Of the substitution reactions, that with chloroform is the simplest as there is only one replaceable hydrogen per molecule. The reaction has been studied both in the gas phase and in carbon tetrachloride solution. The quantum efficiency is high, and the kinetics are:

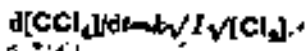

The chlorine atoms produced by the light react thus:

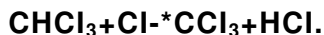

Repeating steps in the reaction chain are caused by:

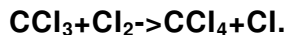

Finally, to fit with the experimental kinetics, the chain-ending process must be assumed to be:



In presence of oxygen, photosensitised oxidation occurs giving phosgene. Possibly an intermediate radical CCl<sub>3</sub>O<sub>2</sub> is formed, but the kinetics do not permit of a complete formulation of the mechanism.

Saturated hydrocarbons can be photochemically chlorinated in the gas phase or as liquids. Unless explosive reaction sets in through the use of too high a light intensity, chlorine atoms replace hydrogen atoms without the breaking of C-C links. The reactions have chain mechanisms, are very susceptible to the presence of oxygen, and give complex mixtures of products. No useful generalisations are available. The production of chlorinated derivatives of methane is very difficult to control; simultaneous chlorination to all the products occurs. Toluene photo-chlorinates in its side-chain, and fatty acids in the α-position. The use of boiling liquids in the above chlorinations, which are typical of certain organic preparations, is to increase the rate by driving off oxygen which acts as an inhibitor by interfering with the intermediate chain processes.

The simplest addition type of chlorination is that of tetrachloroethylene. The kinetics are:

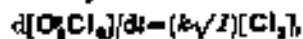

differing from those of the chloroform reaction in that the chlorine appears as the first power. The quantum efficiency is high, and the following series of steps provide a mechanism:

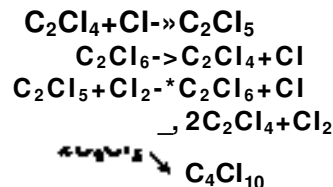

The chief product is hexachloroethane, but a few per cent of C<sub>4</sub>Cl<sub>10</sub> is formed, presumably by combination of C<sub>2</sub>Cl<sub>5</sub> radicals. The assumption of other chain-ending processes its reaction (3) of Table V, or interaction of C<sub>2</sub>Cl<sub>5</sub> radicals and chlorine atoms, leads to a kinetic expression different from that found. In presence of oxygen the rate of photo-chlorination is greatly reduced and photosensitised oxidation of C<sub>2</sub>Cl<sub>4</sub> to trichloroacetyl chloride and phosgene occurs. The kinetic data do not permit the details of this reaction to be elucidated, but it is likely that the intermediate radical C<sub>2</sub>H<sub>5</sub>O<sub>2</sub> is formed. The lower chlorinated ethylenes are photo-chlorinated (by addition mechanism) according to a similar scheme to the above. The behaviour of ethylene is somewhat different; the kinetics indicate that chlorine disappears at a rate proportional to the first power of the absorbed light intensity and independent of other variables. A chain-ending process appears to be a reaction between ethylene and an intermediate atom or radical, instead of a bimolecular atom-radical reaction which in the other instances gives rates dependent on the square root of the light intensity.

The photochemical bromination of saturated organic compounds is much slower than the corresponding chlorination, but quantitative details are lacking. The bromination of unsaturated compounds is also imperfectly understood. P<sup>1</sup>, chloroethylene, cinnamic acid and stilbene have been examined. In the two first examples the kinetics vary with the



pressure and with the light intensity, and it appears that the product ( $C_2H_2Cl_2Br_2$  or  $C_2Cl_4Br_2$ ) is never obtainable quantitatively since it is subject to decomposition by reaction with bromine atoms simultaneously with its formation. Oxygen exerts further complicating effects. The photobromination of cinnamic acid in carbon tetrachloride solution proceeds under ordinary conditions at a rate proportional to the square root of the light absorbed and to the bromine concentration; the simple interpretation of this result, however, is invalidated by the presence of dissolved atmospheric oxygen. When this is entirely excluded the photochemical rates are vastly increased, but their determinations are rendered exceedingly difficult by a rapid thermal bromination which sets in when oxygen is absent. The presence of radicals consisting of one atom of bromine attached to the cinnamic acid molecule, and taking part in extensive chain reactions, may be taken as reasonably certain. These may proceed to further bromination (the reaction

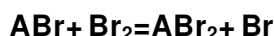

being reversible (A=ethylene compound)), or may give dimers of cinnamic acid as a by-product ( $2ABr \rightarrow A_2 + Br_2$ ), or in presence of oxygen may be oxidised in ways not yet understood. Another type of photo-reaction showing that even the formation of radicals such as ABr is a reversible process is that of maleic acid or ester with bromine. A small amount of substitution to the dibromosuccinic compound is observed, but the chief change is that of the maleic compound to the fumaric. The intermediate radicals ABr must be capable of internal rotation to give the change to the geometric isomer, and must then largely lose the attached bromine atom by further reactions.

The photo-reactions of iodine with organic compounds are relatively few. Saturated molecules are not affected. Addition occurs to certain olefins, but iodine-sensitised decomposition of the products is marked. Ethylene iodide and iodine react photochemically to give ethylene and iodine, balancing the reverse reaction to give a photochemical "stationary state." The intermediate  $C_2H_4I$  must be assumed to react with iodine molecules by a reversible process and to dissociate reversibly. The chain-ending process of this reaction cannot be decided from the at present inadequate experimental data. As with bromine, iodine photosensitises geometric-isomer transformations (e.g., of allocinnamylidene acetic acid) through the transient intervention of radicals of type AI.

Methane, ethane, and other saturated hydrocarbons are transparent to all light except that of very short wave-length (<1,500 A.). In this region photochemical decomposition is observed giving exceedingly complex mixtures of products. There is little doubt that these arise by secondary reactions of radicals formed by the splitting off of hydrogen atoms from the original molecules. Ethylene, absorbing below 1,700 A., gives polymers, methane, acetylene, and hydrogen. Acetylene also polymerises below 2,150 A. The quantum yields of the above are of the order 0.1-10. Benzene is decomposed

by ultra-violet light at about 2,000 A. to give phenyl radicals and hydrogen atoms; at longer wave-lengths in presence of oxygen complex oxidation processes occur. Anthracene in solution absorbs in the near ultra-violet region and polymerises to dianthracene; in carbon disulphide solution and in presence of oxygen a peroxide is formed.

Organic halides undergo a primary photo-decomposition to alkyl radical and halogen atom; these take part in secondary reactions to give a variety of products which are increased in complexity by the presence of oxygen. In the case of methyl iodide the quantum yield is peculiarly low, evidently owing to recombination processes, since the spectrum of the substance indicates a primary process of photo-dissociation.

Alcohols and ethers are very transparent to ultra-violet radiation and decompose only at short wave-lengths, the products being complex.

The photo-reactions of aldehydes and ketones have been much studied. The simpler molecules of this type have somewhat weak absorption bands near 3,000 A.; the physical process of light absorption consists in an electron from one of the "lone-pairs" of the oxygen atom passing to an "anti-bonding orbital" between the carbon and oxygen. The spectra of the smaller molecules show sharp bands on the long-wave side which merge into diffuse or continuous absorption further into the ultra-violet. This evidence points to dissociation of the excited molecule at the shorter wave-lengths. The photochemical evidence indicates dissociation with a longer delay period in the longer-wave region as well. Formaldehyde decomposes by the initial process:  $H_2CO + hv \rightarrow H + HCO$  below 2,750 A., hydrogen atoms being experimentally detectable in the system, but the quantum efficiency of unity shows that the first products ultimately form the stable products  $H_2 + CO$  without setting up chains (at temperatures below  $0^\circ C$ ). At longer wave-lengths the primary process seems to be:

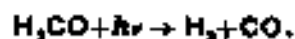

This process involves a longer delay, as shown by the sharpness of the lines of the absorption spectrum. At high temperatures a chain mechanism occurs; whether this is from further reaction of the hydrogen atoms or from excited  $H_2CO$  molecules is not known.

Acetaldehyde (as vapour) gives chiefly methane and carbon monoxide as photo-products with a quantum efficiency somewhat less than unity. At the shorter wave-lengths some hydrogen is formed, fewer methyl radicals are produced, and the carbon monoxide is formed at a higher quantum efficiency (approaching 1). Very intensive studies have been made of this photo-reaction; the changes of quantum efficiency of carbon-monoxide formation under different experimental conditions and the nature of the by-products have been examined. A polymer, formaldehyde, glyoxal, and diacetyl are formed in small amounts, the last substance giving rise to a fluorescence observed when light of wave-length 3,350-2,600 A. is used. It is pro-

visionally concluded that the main processes are at all wave-lengths:

- (a)  $\text{CH}_3\text{-CHO} + \text{J} \rightarrow \cdot\text{CH}_3 + \text{CHO}$ .  
 (b)  $\text{CH}_3 + \text{CHO} \rightarrow \cdot\text{CH}_2\text{CHO}$ .  
 (c)  $\text{CH}_3 + \text{CH}_3\text{CHO} \rightarrow \text{CH}_4 + \text{CH}_2\text{CO}$ .  
 (d)  $\text{CH}_3\text{CHO} + \text{CHO} \rightarrow \text{CH}_3\text{CO} + \text{H}_2\text{fCO}$ .  
 (e)  $\text{CH}_3\text{CO} + \text{M} \rightarrow \text{CH}_3 + \text{CO} + \text{M}$ .  
 (f)  $2\text{CH}_3\text{CO} \rightarrow \text{CH}_3\text{COCQCH}_3$ .  
 (g)  $2\text{CHO} \rightarrow \text{CH}_2\text{O} + \text{CO}$ .

The back reaction (6) is necessary to account for the quantum efficiencies being somewhat less than unity. Some primary formation of methane and carbon monoxide directly from excited acetaldehyde molecules may also occur. At elevated temperatures the reaction entirely changes its kinetics and becomes a long-chain process proportional to the square root of the light absorbed. This seems to be due to reaction (e) being speeded up relatively more than the other reactions so that repeating steps are set up which are terminated chiefly by bimolecular collisions between the radicals (e.g., reaction (g)).

Higher aliphatic aldehydes appear to decompose by two primary processes:

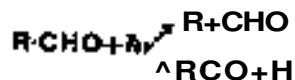

The radicals further react in a variety of ways to give saturated and unsaturated hydrocarbons with more or fewer carbon atoms than in R; the other main product is carbon monoxide. Aldehydes with conjugated structures absorb at somewhat longer wave-lengths than the simple compounds, and appear much more stable to illumination; quantum yields of carbon monoxide formation are low. In the case of acetaldehyde, polymerisation is the chief photo-change observed.

*Ketones* (as vapour) dissociate in ultra-violet light to give radicals. *Acetone* gives as final products chiefly ethane and carbon monoxide; some diacetyl is also formed. The quantum efficiency is less than unity at low temperatures, but rises to 1 either when iodine is added (whereby  $\text{CH}_3$  radicals are removed as  $\text{CH}_3\text{I}$ ) or at temperatures about  $100^\circ$ . It is concluded that the primary chemical change is:



followed by a back reaction of the radicals to give acetone, further reaction of the radical  $\text{CH}_3\text{CO}$  to give either  $\text{CH}_4$  and carbon monoxide or diacetyl, and combination of  $\text{CH}_3$  radicals to give ethane. The ethane and diacetyl formations are believed to occur on the walls of the vessel. Methyl radicals can be shown to be present in the reacting system by the use of the metallic mirror technique; they cannot be assumed to give ethane by bimolecular collisions in the gas since this reaction is comparatively slow at low temperatures. Higher ketones also photolyse to hydrocarbon and acyl radicals the subsequent decomposition of which lead to carbon monoxide, acetone, and mixtures of

saturated and unsaturated hydrocarbons as final products. Cyclic ketones such as cyclohexanone give carbon monoxide and other products following from the consequent rupture of the ring?

*Acetone* in the liquid state gives no gaseous products on exposure to ultra-violet light. This has been explained as a "cage" effect due to surrounding molecules. A molecule, after absorbing a quantum, dissociates into radicals, but these are hemmed in by the liquid structure and forced to collide again many times before they have a chance to separate. They thus have a good chance of recombining to form the original molecule and to nullify the photo-change.

Solutions of *sugars* decompose in ultraviolet light to give carbon monoxide, carbon dioxide, methane, hydrogen and other products. These complex changes have not been elucidated.

*Fatty acids* have structureless spectra at shorter wave-lengths than the corresponding aldehydes. On photolysis carbon dioxide is formed, together with hydrocarbons and other products. No intelligible data exist for the photo-decomposition of *esters*.

The complex *oxalates*, *citrates*, *tartrates*, etc., of iron (ferric), cobalt (-ic), manganese (-ic), and uranium (uranyl) are photosensitive in the near ultra-violet and short-wave visible region. The reaction of the first three causes carbon-dioxide evolution, reduction of the metal to a lower oxidation state, and oxidation of the acid residue; uranyl oxalate, however, gives carbon monoxide and dioxide without much reduction to uranous ion. Ammonium ferri-oxalate or citrate is used for "blue prints"; the action of light gives ferrous ion, which combines with potassium ferriocyanide to give Turnbull's blue. Solutions of *ions of metals* in higher valency states are usually photosensitive, but the photo-change is sometimes masked by rapid re-oxidation processes; in alcoholic or ether solutions salts such as ferric chloride are reduced by light with oxidation or chlorination of the solvent.

Organic *nitro-compounds* give complex photo-products in ultra-violet light. Conjugated nitro-compounds are relatively stable to light (e.g., nitrobenzene), but lengthy exposure gives a variety of products for which no simple mechanism can be given. *o-Nitrobenzaldehyde* changes in light to *o-nitrosobenzoic acid*; its isomers do not undergo a similar reaction. *Nitroso-compounds* in the unimolecular form absorb red light and decompose in a fairly simple manner with elimination of hyponitrous acid.

*Ammonia* shows a series of diffuse bands around 1,900 Å., indicating a predissociation process:



The alternative dissociation to  $\text{NH}$  and  $\text{H}_2$  seems excluded because liquid ammonia does not decompose photochemically, a behaviour which may be interpreted as a back recombination of  $\text{NH}_2$  and  $\text{H}$  caused by the "cage effect" of the surrounding liquid in preventing their ready escape. The presence of hydrogen atoms is also demonstrable by the *para* → *ortho* hydrogen reaction. The ultimate products of ammonia photolysis are nitrogen, hydrogen, and

some hydra-sine, the quantum efficiency being about 0.25 and varying somewhat with the conditions. The exact mechanism still remains to be settled; it has not yet been decided whether the hydrazine formation takes part in the main decomposition or whether it is a side reaction. It seems probable that wall effects which have not been correctly taken into account explain some of the divergencies of view on this photo-change.

*Aliphatic amines* photolyse by a primary dissociation of a hydrogen atom from the NH<sub>2</sub> group. The further changes of these give complex products.

Many *oxides of non-metals* are decomposed photochemically. *Carbon dioxide* gives CO+O at wave-lengths shorter than 1,690 Å. *Nitrous oxide* gives nitrogen, oxygen, and nitric oxide beyond 1850 Å., probably by two primary processes giving N<sub>2</sub>+O and NO+O. The photodecomposition of *nitrogen dioxide* has interesting features. In the blue and violet regions the absorption spectrum is sharp, the gas is fluorescent at low pressures, and the quantum efficiency of decomposition is low. At about 3,700 Å. the spectrum becomes diffuse (at higher pressures), fluorescence ceases, and the quantum efficiency of decomposition rises to nearly 2. At shorter wave-lengths the reaction is one of induced pre-dissociation:

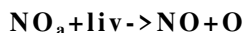

followed by:

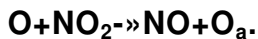

*Chlorine monoxide* shows a continuous spectrum and photodissociates:



followed by:

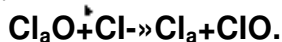

*Chlorine dioxide* decomposes by predissociation, giving chlorine atoms, oxygen, ClO, and oxygen atoms. The final products of decomposition of both these oxides are complex; the former gives chiefly chlorine, oxygen, and some ClO<sub>2</sub> and Cl<sub>2</sub>O<sub>6</sub>, and the latter gives large yields of Cl<sub>2</sub>O<sub>6</sub>. The quantum yields, range from about 2 to 10.

In presence of reducing agents *dichromates* in solution are photochemically sensitive to blue, violet, or ultra-violet light. Mixtures of sodium dichromate and gelatine or other colloids are used in various photo-reproductive processes in industry. Under the influence of light the colloid is oxidised by the dichromate and rendered insoluble in warm water. The mechanism of the change is very imperfectly understood. A simpler system is aqueous dichromate and an aliphatic primary alcohol. The alcohol is oxidised to aldehyde with an efficiency approaching three molecules of alcohol per quantum under the optimum conditions of concentration; usually the efficiency is less for the reasons below. At low alcohol concentrations the rate of oxidation is low, presumably because the dichromate is deactivated before colliding with an alcohol molecule. At high alcohol concentrations (>80% by volume) a precipitate of

basic chromium sulphate is formed which reduces the light absorption by scattering. In neutral solutions a brown precipitate of chromium chromate forms; this is prevented by the addition of acid. In alkaline solutions the oxidation does not occur, the CrO<sub>4</sub><sup>2-</sup> ion being inactive photochemically. The best conditions are: alcohol, 70-80% by volume, dichromate, 0.1N., with sufficient acid to prevent the solution becoming alkaline during reaction; the chromium is then all reduced to the trivalent form in solution after sufficient exposure to the light. As the constituent ions of dichromate solutions are rather uncertain *i.e.*, whether Cr<sub>2</sub>O<sub>7</sub><sup>2-</sup> or HCrO<sub>4</sub> the representation of the photo-change by equations is scarcely possible; it is fairly certain, however, that the process is one of successive steps in which the chromium passes by intermediate valencies from six to three.

The absorption of light by *double-bonded organic substances* causes an electron to pass into an "anti-bonding orbital" of the double bond, and thereby to lower its resistance to rotation. *Cis-trans* changes are facilitated in this way. The reactions are normally carried out in solution. The changes occur with quantum efficiencies about 0.05 to 0.5, and are complicated by several effects such as photolysis and side reactions. Both isomers absorb light, but in different proportions at different wave-lengths, and photo-stationary states are usually set up where the *cis* → *trans* rate balances the reverse change, the equilibrium point varying with the wave-length. Such photo-stationary states are given by the systems: *maleic-fumaric acids*; *citraconic-mesaconic acids*; *cinnamic-isocinnamic acids*, and numerous other ethylene derivatives when exposed to ultra-violet light at about 3,000 Å. *Azobenzene (trans)* in solution is photochemically converted by blue light largely into the *cis* form. *Benz-smiti-aldoxime* changes photochemically to the *syn*-form. In the *solid* state, presumably because the crystal structure prevents rotation but facilitates dimerisation, many ethylenic compounds give derivatives of *eyefobutane*, *e.g.*, *cinnamylidene malonic acid*, in the blue region, gives:

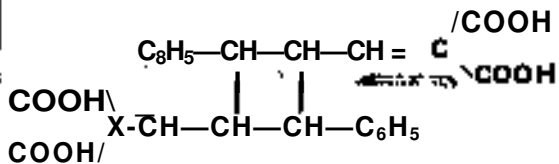

Similarly, crystalline *cinnamic acid* dimerises, with the peculiarity of giving *α-truxillic acid* under normal conditions and the isomer of this product, *β-truxinic acid*, if it has recently been precipitated rapidly from solution, probably due to its existence in a different crystalline form in the latter case.

The subject of *photo-oxidation* is one of very great importance but of extreme difficulty of interpretation, and much remains to be studied. The photo-oxidation of *aldehyde* (gaseous or dissolved) by oxygen is a chain reaction with the kinetics:  $\frac{dx}{dt} = \{k^1 I\} [A]$ , the rate being proportional to the square root of the light

intensity, directly as the aldehyde concentration, and independent of the oxygen concentration. {Independence of oxygen concentration is a common and usually puzzling feature of oxidations.) The mechanism appears to be:

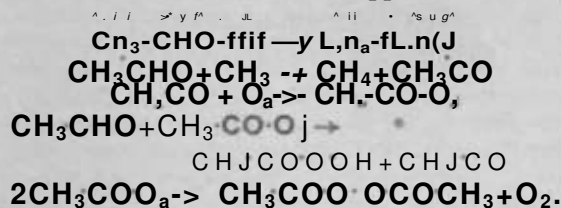

This accounts for the kinetics and for the two observed products, peracetic acid and diacetyl peroxide. In presence of alcohol the chains are inhibited and the rate becomes directly proportional to the light intensity, probably through the replacement of the last {chain-ending} reaction by :

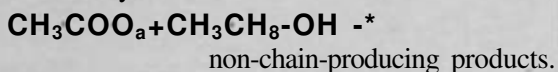

The photo-oxidation of *ethylnic* compounds by oxygen is technically important, in the "drying" of oils, in the development of rancidity in fats, and in the deterioration of rubber in light. The reaction proceeds by a chain mechanism of unknown nature, capable of inhibition by suitable reducing agents (often present in the impure substance itself), and followed by further slow thermal reactions giving a number of products. Peroxides are detectable during the  $\bullet$  reaction; they apparently have a hydroperoxide structure in which the double bond is still present, e.g., cyclohexene gives:

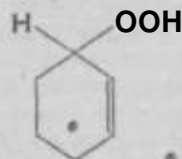

How the oxygen attacks the  $\alpha$ -carbon atom when the double bond absorbs the light is unknown. The final products may be aldehydes,

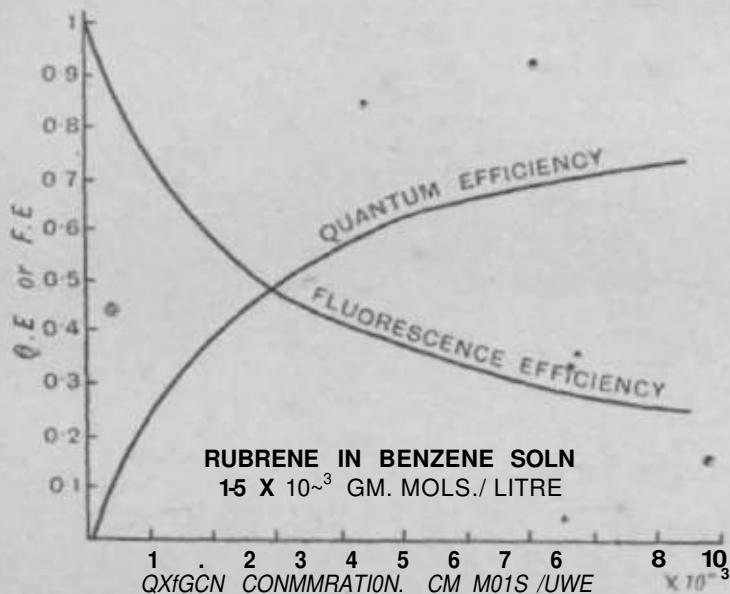

Fia. 4.

ketones, acids, ethylene oxides, polymerised and oxidised substances, and molecules derived by the complete rupture of the double bond.

The photo-oxidation of aromatic hydrocarbons seems a somewhat simpler process than the foregoing, but nevertheless presents some puzzling features. In the first place, solutions of aromatic hydrocarbons are fluorescent, and the fluorescence is "quenched" by dissolved oxygen. In the following simple mechanism:

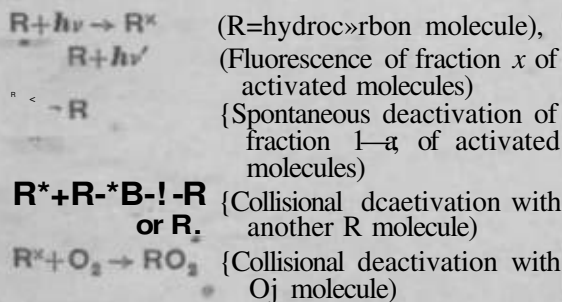

it can easily be shown that:

$$\begin{aligned}
 & \text{Fluorescence efficiency (F.E.)} \\
 & = x / (1 + k_1[\text{R}] + k_2[\text{O}_2]) \\
 & \text{Quantum efficiency of oxidation (Q.E.)} \\
 & = k_2[\text{O}_2] / (1 + k_1[\text{R}] + k_2[\text{O}_2])
 \end{aligned}$$

In the case of the red hydrocarbon *nitrobenzene* (5:6:11:12-tetrahydrophenanthrene) in benzene solution,  $x$  is practically unity, and at small nitrobenzene concentrations the term  $k_1[\text{R}]$  is small; consequently, on the above scheme :

$$\begin{aligned}
 & \text{F.E.} = 1 / (1 + k_2[\text{O}_2]); \\
 & \text{Q.E.} = k_2[\text{O}_2] / (1 + k_2[\text{O}_2]); \\
 & \text{F.E.} + \text{Q.E.} = 1.
 \end{aligned}$$

If the above mechanism is correct, therefore, the plot of fluorescence quenching against oxygen concentration should give a curve which is the mirror image of the quantum-efficiency curve. Fig. 4 shows that for certain concentrations this

is nearly true. The product is a perfectly stable colourless peroxide of formula  $RO_a$  (R=rubrene)? This apparent simplicity of interpretation, however, is marred by the fact that at high rubrene concentrations the photo-oxidation observed is somewhat higher than expected, and at low rubrene concentrations it falls off too much. Other processes must be acting simultaneously and complicating the reaction scheme, which cannot therefore be said to be really understood.

When exposed to long-wave ultra-violet light, solutions of anthracene deposit dianthracene; the dimerisation appears to be fairly closely the mirror-image of the fluorescence quenching at high concentrations due to other anthracene molecules. \*In presence of oxygen photo-oxidation occurs, and from carbon disulphide solutions dianthracene peroxide, believed to be:

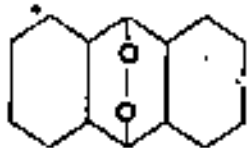

is formed. (The peroxide of rubrene probably has a similar bridge structure.) In this instance, however, it has not been possible to reconcile the kinetics of the photo-oxidation with the quenching of the fluorescence by oxygen. This difficulty is even more marked with solutions of naphthalene. Dissolved oxygen quenches the fluorescence of this substance about ten times more strongly than it affects the fluorescence of rubrene or anthracene solutions, yet the amount of photo-oxidation which occurs is indetectably small. Here the "quenching" complex  $RO_a$  must almost entirely dissociate again into  $R + O_2$  without yielding an oxidation product. In the case of benzene, photo-oxidation in ultra-violet light gives unidentified but obviously polymerised oxidation products, possibly through the intermediate formation of \*

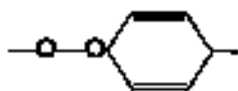

In other examples, e.g.,

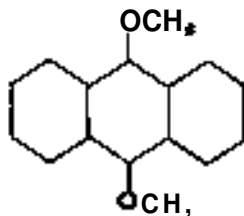

which is photo-oxidised ultimately to the quinone, the high rate of the reaction seems to indicate a chain mechanism.

The photochemistry of dyes viewed from the industrial standpoint is dealt with in a separate section. The fading of dyes in light is not a simple process, and may arise from oxidation (especially basic dyes), from reduction by interaction with the fabric (especially direct dyes on cotton), or from photolysis of the dye molecule to colourless products. Fluorescent dyes are usually more photosensitive than non-fluorescent

ones. This is because molecules of the former have "half-lives" of about  $10^{-8}$  second before they lose energy by radiation, and during this interval they may undergo chemical reactions by collision with other molecules; non-fluorescent dyes lose their energy in a much shorter period by a process of internal deactivation (cf. Fig. 2). Reaction and fluorescence in fluorescent dyes are alternative processes. An interesting example is a dilute solution of thiovine in presence of ferrous ions. The fluorescence of the dye is "quenched" by the ferrous ions, and a photo-change occurs resulting in the reduction of the dye to a colourless substance while the ferrous ions become ferric. The change reverses itself in the dark:

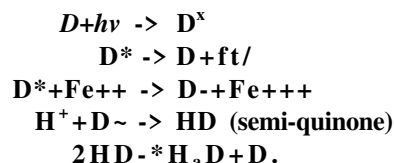

Solutions of dyes and other coloured substances in presence of dissolved oxygen may show fluorescence quenching, photo-oxidation, or photosensitisation. Basic dyes, as Uranine, are bleached in solution only when oxygen is present. In certain other cases, e.g., solutions of rubrene, oxygen is taken up on exposure to light to give an oxidation product, but if a reducing agent ("acceptor") is simultaneously present the oxygen is transferred to oxidise this and the light-absorbing substance remains largely unchanged (photo-sensitized oxidation). These processes are understandable qualitatively, but the details of behaviour of particular systems are sometimes complex.

Orientation and Photochemistry.—When plane-polarised light falls on a molecule such as azobenzene the light is absorbed only when the electric vector is oriented to the molecule, in this case along the  $N=N$  bond. Consequently molecules oriented in crystals or on cellophane films, etc., appear to show different photochemical sensitivities in plane-polarised light according to the direction of the electric vector. Similarly, if photo-active molecules are rigidly held at all orientations in a gel and are exposed to plane-polarised light, only those molecules suitably oriented to the electric vector will decompose, so that the system itself become optically dichroic, i.e., show different extinction coefficients to plane-polarised light of different vector directions.

Some commonly used photochemical terms not dealt with above are explained below.

Asymmetric Photosynthesis.—Circularly polarised light is unequally absorbed by a mixture of two optical isomers, though the difference in absorption is very small. Illumination of a suitable racemic solution with circularly polarised light should theoretically decompose the form faster than the other and leave an excess of one optically active isomer.

Beer-Lambert Law (v. Vol. VI, 1766)\_\_\_

$$I_1 = I_0 e^{-\epsilon c d} = I_0 10^{-\epsilon c d}$$

$$\text{or } \log_{10} \frac{I_1}{I_0} = -\epsilon c d$$

where  $I_0$  = incident intensity,  $I$  = transmitted intensity of light falling normally on a layer of isotropic substance of thickness  $d$  cm. and of a concentration  $c$  g.-mol. per l.;  $a$  and  $\epsilon$  are constants,  $e$  is called the "molar extinction coefficient."

Light absorbed =  $J_0 - J_t = J_0(1 - 10^{-\epsilon c d})$ . This law is valid strictly only for monochromatic radiation and for very dilute gases or solutions. In practice "monochromatic lines" are narrow bands of finite width,  $e$  varies with wave-length, and in systems where the variation is large over the narrowest wave-length interval usable in the experimental arrangement the light transmission will appear to deviate from the law (e.g., absorption of mercury vapour at 2,537\*5 A.). The law may also appear to fail when applied to non-cubic crystals, owing to variations of  $c$  with direction (dichroism), when chemical change occurs (as the  $N_2O_4 \rightleftharpoons 2NO_2$  system; solutions of dyes which associate, dichromate chromate in water), when line-broadening occurs through collisions in gases (e.g., iodine vapour in presence of inert gases), and where solvent effects cause varying molecular distortions in regions of higher concentration.

Grotthus-Draper Law (v. Vol. VI, 137d).—Only light which is absorbed by a system is capable of producing chemical change.

Half-life of Molecules.—The time taken for one-half of the active molecules in a system to die away after the source of activation is removed.

Induction Period.—A period at the beginning of a photochemical reaction when nothing appears to happen, followed by the reaction accelerating to a "normal" rate. It is due either to the photochemical destruction of some substance inhibiting the reaction, as by acting as a chain suppressor or as an "inner filter," or to the production of some intermediate which catalyses the secondary reactions.

Inner Filter.—If a photo-active substance is accompanied by another inert light-absorbing substance the absorbed light is shared between the substances in the ratios:

$$\frac{\epsilon_1 c_1}{\epsilon_1 c_1 + \epsilon_2 c_2} \quad \text{and} \quad \frac{\epsilon_2 c_2}{\epsilon_1 c_1 + \epsilon_2 c_2}$$

where the  $\epsilon$ 's and  $c$ 's are the extinction coefficients and concentrations of the substances. Inner filter may also be intramolecular if more than one group absorbs the light and only one (energetically isolated from the others) is photo-active.

Monochromator.—A specially designed high-aperture (about 1/3) prism spectroscope with adjustable slit in the plane of the spectrum for the production of monochromatic visible or ultra-violet light.

Morse Equation.—An empirical equation approximating to the curves of potential energy of a diatomic molecule as Fig. 1; Potential energy of vibration =  $D \left(1 - \frac{a}{r-r_0}\right)^2 - D$ , where  $D$  is equal to the dissociation energy,  $a$  is proportional to the force-constant of the link,  $r$  the distance between the nuclei, and  $r_0$  the distance when the nuclei are taken as having no vibrational energy. (See also Vol. VIII, 197a.)

Pauli Exclusion Principle.—The principle that not more than two electrons can simultaneously occupy one orbital, and if there are two, they must have opposite "spin."

Photochemical Equivalence Law.—A law more honoured in the breach than in the observance. Einstein first pointed out that since energy is absorbed by molecules in quanta a simple connection might be expected between the number of quanta absorbed in a photochemical experiment and the number of molecules changed. The ratio (Molecules changed)/(Quanta absorbed), called the quantum efficiency, should be unity on a naïve application of the law. This is true only if "molecules changed" refers to molecules physically activated by the light, and is no more than a statement of the fundamental postulate of the quantum theory. The number of molecules actually chemically changed at the end of an experiment almost always differs greatly from the number of quanta absorbed owing to the effects of deactivation, chain reactions, etc., which follow as secondary changes on the primary act of absorption.

Photochemical Threshold.—A point in the spectrum where the quantum efficiency of a photochemical change rises from zero at the longer to finite values at the shorter wave-lengths. This should not be confused with the setting in of photochemical change at a particular wave-length merely because the substance begins to absorb there; a true "threshold" should lie inside an absorption band. The energy corresponding to the "threshold" may sometimes be related to probable mechanisms of decomposition, e.g., nitrogen dioxide (gas) and chlorine dioxide (in carbon tetrachloride solution) photo-decompositions.

Photosensitisation.—The absorption of light by one coloured substance bringing about a photo-change in a non-absorbing substance simultaneously present, e.g., bromine sensitised *els-trans* change of maleic ester. A number of interesting photosensitised decompositions are produced by mercury atoms excited by 2,537\*5 A. and by cadmium atoms by 3,261 A. Hydrogen is caused to dissociate to atoms, and hydrocarbons to decompose to a variety of products. Metallic hydrides are detectable spectroscopically in the system; possible reactions are:

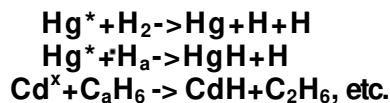

The detailed processes of the secondary changes are still imperfectly understood, and show certain peculiarities. For example propane with excited mercury atoms gives chiefly hydrogen and hexanes, while with excited cadmium atoms C—C scission occurs in addition giving some methane and propane.

Photo-stationary State.—A state of dynamic equilibrium reached in a system exposed to light. It may refer to the reactants and final products or to reactants and some transient intermediate radical or atom. Several types are possible, depending on (a) the number of molecules concerned on each side of the

equilibrium, and (b) the number of photo-active constituents of the system. Examples,

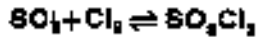

(all molecules photo-active to varying degrees),  $H_2 + Br_2 \rightleftharpoons 2HBr$  (bromine alone photo-active at longer wave-length; hydrogen bromide at shorter).

An important principle in deducing theoretical kinetics from proposed mechanisms is that the rate of formation of a transient must equal its rate of removal in any photo-reaction; e.g., in the hydrogen-bromine reaction, supposing the stages to be

- |  |                      |
|--|----------------------|
| 1. $Br_2 \xrightarrow{h\nu} Br + Br.$      | Rate $k_1 I$         |
| 2. $Br + Br \xrightarrow{M} Br_2 + M.$     | „ $k_2 [Br]^2 [M]$   |
| 3. $H_a + Br \rightarrow HBr + H.$         | „ $k_3 [H_a] [Br]$   |
| 4. $H + Br_a \rightleftharpoons HBr + Br.$ | „ $J b_4 [H] [Br_2]$ |

and assuming that reactions (3) and (4) are slow compared with (2), we have for the bromine atoms:

$$V = k_2 [Br]^2 [M], \text{ since (3) and (4) are small,}$$

$$\text{whence } [Br] = \sqrt{\frac{V}{k_2 [M]}}$$

and for the hydrogen atoms:

$$k_3 [H] [Br] = k_4 [H] [Br_2]$$

The rate of hydrogen bromide formation is then:

$$k_3 [H] [Br] = k_4 [H] [Br_2] = \frac{2k_3 [H_2] [k_1 I / k_2 [M]]^{1/2}}{2k_3 [H_2] (k_1 I / k_2 [M])^{1/2}}$$

in agreement with the experimental kinetics. (M=any molecule in the system.)

**Phototropy.**—Certain organic substances, e.g., benzaldehyde phenylhydrazine, darken or change colour when exposed to light without any detectable production of a new substance or change of crystalline form. The reverse reaction occurs in the dark. The reason is still obscure.

**Photo-dichroism.**—If a film containing a photo-active substance, e.g., some silver chloride preparations, some elements of which are sensitive to red light, some to green, and some to blue, be exposed to red light, only those elements absorbing red will be affected, so that the resulting product will be coloured when viewed in white light. The effect is made easier to investigate by the use of coloured plane-polarised light. This is chiefly absorbed by those molecules which are correctly oriented to the electric vector of the incident light, and these only are photochemically affected. The result is that the film colours and partially polarises a beam of unpolarised white light in which it may afterwards be viewed.

**Third Body.**—When two atoms X collide they cannot normally form a molecule  $X_2$ , since all their kinetic energy is converted into internal energy of  $X_a$  which must be quantised and will scarcely ever "fit" any arbitrary collisional energies. If a third molecule is present,



any excess energy can be carried away by the kinetic energy of separation of  $X_2$  and M. The principle must also apply to the reverse reaction of  $X_a$  dissociating by a thermal reaction.

References.

W. A. Noyes and P. A. Leighton, "The Photochemistry of Gases," Reinhold, New York, 1941; G. K. Rollefson and M. Burton, "Photochemistry," Prentice Hall, New York, 1939.

E. J. B.

PHOTOGRAPHY.

Introduction

- I. The light-sensitive material (p. 545c).
- II. The action of light (p. 555c).
- III. The development of the latent image (p. 559(2)).
- IV. The fixation and permanence of photographs (p. 563d).
- V. The quantitative response of photographic material to light (p. 566a).
- VI. The reproduction of photographs (p. 570d).
- VII. The recording and reproduction of colour (p. 575d).

INTRODUCTION.

The growth of photography as a large industry, and its spread year by year into new fields of usefulness, is undoubtedly due to its close relation to vision. In some directions in recent years its property of light sensitiveness, which caused most amazement in the early days of the art a hundred years ago, has declined in importance with the advent of new electronic devices, but photography still remains supreme in the recording of images, where the whole significance of a pattern of light and shadow depends on their spatial relations as well as their intensities. The photographic-materials manufacturer, therefore, has only half completed his work when he has made a light-sensitive product; he has further to spread it uniformly over immense areas of various types of support, because—apart from certain applications where the spreading is more conveniently done immediately before use at a customer's works—his light-sensitive product has no usefulness until it is put in this form where it can register the point to point variations of light and shade in an image, yielding a photograph in which the significance lies as much in the spatial relations between the elementary patches of "photographic density as in their value.

Nevertheless, both in the historical development of the art and in modern large-scale manufacture, the preparation of the light-sensitive "emulsion" and its subsequent coating on to various supports are distinct operations, the requirements of the first, indeed, taking precedence over those of the second, so that the very design of coating machinery is dictated by the physical and chemical properties of the light-sensitive emulsion, which cannot be radically altered without destroying its desired response to light.

The nature of image reproduction requires only that the light-sensitive layer shall respond progressively to the light incident on any point and that each element of surface remains fixed relative to the other elements of the surface and responds to the light independently of other elements. Quite a number of distinct photographic processes have therefore been proposed, and some of them still enjoy a limited commercial use, but because of the relation of photography to vision, only those processes most capable of recording what the eye can see have survived for camera use, which in practice means that they are confined solely to processes



of light recounted in Section II. Suffice it to say here that the photographic plate is never used in precise work except as a null instrument, to determine when two streams of radiation are equal in intensity. Thus in absorption spectroscopy a comparison spectrum of the source is impressed repeatedly on the plate through a rapidly rotating sector wheel so that a series of spectra of known and decreasing intensity is recorded. Alongside each the spectrum of the light which has passed through the sample is recorded, for the same average exposure time. On the developed plate the match points of each pair are marked, and if the intensity scale of the series of comparison spectra has been correctly chosen, these give when joined the absorption curve of the sample. The conditions fulfilled in this example are a model for all other applications of photography to photometry, although useful, if legs **reliable**, results can be obtained when one or more of them is neglected. First, the optical densities matched in contiguous areas of the plate. This ensures that local small variations in the sensitivity of the plate, or in the degree of development, apply equally to both patches. Secondly, only regions, where the patches are of equal density, and which have had the same time of exposure, are significant. This does away with the errors due to reciprocity failure (*v. infra*, Section II). For this to be true, however, it is essential that the sector wheel should interrupt the light of the comparison spectra at such a high rate that each grain of the plate receives on the average not more than one quantum of radiation in each flash. The dark periods suffered by any individual grain are then statistically identical with the dark periods (between incident quanta) suffered by a similar grain bathed in the weaker continuous light from the other spectrum. For a one-second exposure, the minimum frequency of interruption is of the order of 100 times a second. Thirdly, the patches to be compared have been produced by radiation of identical spectral quality. If this condition is neglected, the equality of two beams of radiation established photographically may have no relation to visual judgments of equality of the same two colours, equality indeed in each case being *defined* by the physiological and physico-chemical properties of the respective systems. By suitable choice of plate and light filters the overall spectral sensitivity of the photographic system may be brought into approximate equivalence with that of the eye, when all colours which appear identical in brightness, hue, and saturation will register the same. The precision with which this may be done, however, is not high. Heterochromatic photographic photometry is therefore rarely employed except when the plate is calibrated *ad hoc* in terms of the energy of the **radiation** under investigation. Such methods of empirical calibration, while less precise and requiring more experimental care, nevertheless have a wide field of usefulness, from stellar photometry to the plotting of equiluminous zones in comparing street lighting installations. The significance and magnitude of the effects of changes in the conditions can be judged only with a knowledge of the properties of the photo-

graphic material and its quantitative response to light which form part of the science of photography described below in Sections II, III, and V.

### I. THE LIGHT-SENSITIVE MATERIAL.

The modern user of photography, with rare exceptions (as in the photomechanical trade), buys his photographic material ready for exposure, whether it be in the form of glass plate, flexible film, or sensitised paper. It is packed in various ways to suit his convenience, as for instance in a manner allowing of daylight loading, and otherwise to ensure protection of the product for a reasonable storage period. He loads his camera and makes his exposures, which may be exceedingly brief (*e.g.*, 0.001 second). The action of light is not sufficient to yield a visible change, but an image may be *developed* on the material by one chemical treatment, and the image *fixed* by removal of the unexposed and unchanged light-sensitive substance in another. The image so obtained is usually a negative, in which the tones of the original scene are reversed, the dark parts appearing bright and the bright parts dark. Positive photographs are obtained by exposing the negative to light in contact with another photographic material, *e.g.*, paper, whose reaction to light is similar to that of the negative material. This reverses the tones once more, yielding a reproduction of the scene. The original colours do not appear in an ordinary photograph, being represented in monochrome.

The sensitive material, if examined in light before processing, is found to bear a sensitive *emulsion* which may be creamy white, pink or grey in colour, and which can be scratched with the finger nail. It is a suspension of minute crystals of silver halide in gelatin, coated evenly on a suitable transparent or opaque support to yield a dry layer from 4% to 30% in thickness, depending on the particular material. The crystals may be dyed to render them sensitive to coloured light, and it is this which gives the sensitive layer an overall hue distinct from the cream or white of the undyed silver halide. Other agents may be present to harden the layer, to facilitate spreading, and to improve keeping qualities. These will be dealt with in due course. But its essential light-sensitive property, to the preservation or enhancement of which all the manufacturing techniques are directed, resides in the silver halide. The manufacture and properties of silver halide emulsions (as the crystal suspension is called, whether in the liquid, gel, or dried form) will therefore be described **first**.

#### THE SILVER HALIDE EMULSION.

In a first consideration of the action of light on photographic materials the most elementary **particle** that it is needful to study is the single silver halide grain. Each minute crystal in the emulsion responds as a whole. It is either reduced in the developer, or not at all, when it is removed in the fixing bath. The difference between a light tone and a dark tone on the same photograph is merely a difference in the number of grains reduced per unit area. The emulsion maker therefore provides in the silver

based on the light sensitiveness of the silver halides, suspended in a gelatin medium.

While the bulk of all photographic materials made is used for the straightforward recording of visible things, the photographic material capable of this has properties, some necessarily, others as a consequence of its chemical make-up, which render it useful in many directions in industry and science for the recording or demonstration of invisible things. In\* the first class may be put both high-speed photography, where by the application of sufficient light to the object photographed records are obtained in an interval of time so small that any motion of the object is "frozen," and detail made plain which the eye cannot see; and its converse, where by sufficiently long exposures the light from objects so dim as to be invisible to the eye is integrated by the sensitive layer to yield a visible image. Similarly in aerial photography and metallography, although the image photographed is in most cases entirely visible, it is either so fleeting, or so inconvenient to retain while the wealth of information that it contains is extracted, that the photographic record is indispensable. In miniature fluorography the photography is essential for the same reason: to provide a record, to be studied at leisure, of a visible but fleeting image. In the second class may be put the power of the photographic plate, either by its inherent sensitivity or by a sensitivity deliberately added by special chemical treatment, to record extra-spectral invisible radiation. Its power to record variations from point to point in the strength of  $\gamma$ -rays is in daily use, both in industry and medicine. In the ultraviolet, the plate can record by reason of its natural sensitivity up to a limit of  $\lambda = 200 \text{ m}\mu$ , above which wave-length the radiation is absorbed by the gelatin. Plates sensitised by the addition of a fluorescent compound and plates specially made with a minimum of gelatin can record to the limit set by the absorption of water (in the vacuum spectrograph). At the other end of the spectrum recent years have seen successive extensions of the practical limit of records of the infra-red spectrum, until to-day we approach the point where the addition of sensitivity to still longer wave-lengths would cause the plate to be fogged by the thermal radiation from the plate and its wrappings at room temperature even if sensitising dyes sufficiently stable could be found. Within the visible spectrum, photographic materials may be selected with a maximum of sensitivity in the region that it is desired to record, so that with suitable light sources photographs may be obtained by monochromatic light (e.g., as in spectroheliography).

As a scientific instrument the photographic material is used as a recorder of position, and as a recorder of intensity. In science both functions are refined and made quantitative to the degree of precision necessary to give the information sought. The first function alone is involved in the more usual applications of recording, materials, where some other scientific quantity, such as pressure or current, is translated into terms of length by a scientific instrument, and its pointer readings merely trans-

ferred to the photographic material, which for special reasons happens to be the most convenient medium to record them. The much used variable-area system of sound recording is a case in point. Other scientific applications of this function of the photographic plate will occur to the mind in astronomy, where it started a new epoch, in surveying (photogrammetry), and in the more simple applications of qualitative spectrochemical analysis, cloud chamber photography, and X-ray crystallography. Similarly, in document copying and in meter and instrument dial recording the only necessity is that the record should be legible; it is irrelevant whether the tones of the original are reproduced or not. Esthetic considerations, or the need of familiar representation for popular use [e.g., race finish records], may require that they should be approximately true, but the essential information is available on the photograph independently of this. It is therefore almost solely in this field that the non-silver photographic processes have obtained a footing, particularly in the drawing office and engineering workshop, where legibility of the working drawings is all that is needed. The drawing-office processes are limited in their power of rendering fine gradations of tone, and this, quite as much as their comparative low speed, has kept them to this use.

As a recorder of position, photography accommodates all degrees of precision from the snapshot of landscape, where quite large distortions produced by a cheap lens are tolerated without remark, through photo-surveying where the precision is high but can tolerate slight distortions of film support which are corrected by calculation, to the astronomical star chart where profound consequences may hang on a displacement of a few microns. For the highest precision rigid supports of glass or metal are invariably used, and further precautions have to be adopted to minimise distortions due to the colloid nature of the sensitive coating; e.g., avoidance of the edges of the plate, preliminary "annealing" to relieve strains by soaking and redrying, choice of developer to avoid image-wise tanning (which results in distortions due to the more rapid drying of the tanned and less swollen regions), and vigorous agitation of the developer to minimise apparent displacements of images due to an unsymmetrical distribution of the soluble products of the development reaction. The need for these precautions is much reduced by the common modern practice of impressing a grid, say of squares of 5 mm. side, over the whole plate at the time of exposure. All measurements on the plate are referred to the grid lines, so that local distortions of the plate affect both equally and cancel out. The use of photographically impressed axes of co-ordinates and scales, or of other fiducial lines, is common in most other applications of photography to the recording of position, and has opened the field to photographic materials on dimensionally unstable flexible film and paper.

Due appreciation of the reasons for the precautions to be adopted in the use of photography for the measurement of radiation follows on a knowledge of the mechanism of the action

halide grains not only the elementary light-sensitive particles but indirectly the pigment of the finished photographs. The art indeed largely consists in effecting a suitable balance between the requirements of these distinct functions. The balance, moreover, is tipped in opposite directions for negative and for positive materials. For the first, light sensitivity is paramount; for the second, speed can be sacrificed to satisfy other requirements of image colour, gradation, and ease of handling.

**Negative Emulsions.**—In the preparation of emulsions of high speed, the aim is to produce a suspension of grains which are individually of high sensitivity and which each contribute to the developed image as much light-stopping power as is consistent with the resolving power and smoothness of tone required of the material in use. Research and experience extending over a period of sixty years have led to a basic understanding of the successive steps necessary to achieve these aims, although the best detail means of effecting them remain the manufacturing secrets of commercial production. Broadly there are three stages: (a) emulsification and ripening, (b) removal of soluble salts, and (c) digestion (after-ripening). In the first, the silver halide is precipitated in gelatin in darkness and the chemical nature of the grains and the grain-size distribution fixed. In the second, the soluble salts produced by the precipitation reaction are removed. In the third, the emulsion gains speed and contrast by the reaction of sensitisers, contained in or added to the gelatin, with the grains. Further stages, in which the emulsion is sensitised for "doctors" and "added to prepare for coating, may be added to the account.

**Emulsification and Ripening.**—Negative emulsions are prepared by precipitation of mixed crystals of silver iodobromide containing up to 10% of silver iodide, gelatin being present in the solution throughout. The precipitate is then ripened in the presence of a solvent for the silver halide, during which the large grains grow at the expense of the smaller by Ostwald ripening, and small grains coalesce and recrystallise, this process being controlled by the emulsion maker to give the grain-size distribution required. For the precipitation, solutions are prepared containing 10% or slightly more respectively of the soluble halide (e.g., potassium bromide and iodide) and silver nitrate, and gelatin is added to the halide solution to the extent of from 1-6%. Although this gelatin remains throughout and is one constituent of the finished emulsion, it is only a small proportion of the total final gelatin, and is selected for its protective colloid action during precipitation, leaving to further gelatin added at the digestion stage all consideration of contained (impurity) sensitisers. The halide present is always in excess of the stoichiometric quantity required to react with the silver. In "neutral" emulsions this excess may be considerable, as it functions as a silver halide solvent during ripening. In "ammonia" emulsions it may be small, the function of silver halide solvent being taken by ammonia, usually either added as such to the halide solution or added to the silver solution in such quantity as

just to redissolve the silver oxide first formed. On mixture with the bromide it is disengaged from the complex ion and becomes available to assist ripening. The silver solution is added to the bromide solution under accurately controlled conditions of temperature and rate, the bromide solution being vigorously stirred throughout. The first action in the precipitation, which is profoundly affected by the presence of gelatin, is the formation of sub-microscopic nuclei from the momentary high supersaturation produced at the point of mixture. These continue to grow throughout the precipitation stage. In the second stage, the mixed emulsion, to which all the silver has now been added, is held at a temperature not exceeding 50° for "ammonia" emulsions, but which may be as high as 70° or even 90° for "neutral" emulsions, until the required grain-size distribution is achieved.

In commercial production, the precipitation and ripening stages may not be so clearly delimited as in the above outline. By slowing up the rate of addition of the silver, both processes go on concurrently, so that by the time all the silver is added, it is possible for ripening to be complete. Nevertheless, it is possible within limits to reach the same end either by slow addition of the silver, so that the rate of production of nuclei is low, due to a low degree of supersaturation, resulting in large crystals growing on the limited number of nuclei, or by ripening of a fine grained precipitate in the presence of excess potassium bromide or ammonia.

Each particle as it grows is surrounded by an electrostatic double layer which consists of imperfectly oriented ions of the solid plus ions of the solubilising potassium bromide, these ions being more or less hydrated, according as they are less or more completely oriented in the crystal lattice. The hydration consists of an atmosphere of water dipole, which are more or less numerous according as the potential electric moment of the ion is not taken up by its attraction and fixation in the crystal lattice. During Ostwald ripening the double layers surrounding the larger growing particle and the smaller dissolving particle are not ruptured, the effect being in principle a transfer of water from the large to the smaller particle, the energy deriving from the surface energy released as the total surface of the system becomes smaller. Such particles therefore, when brought into collision by the accidents of Brownian movement, do not coalesce. Nevertheless, for a number of collisions, the double layer surrounding each particle is similar with respect to the hydration of the ions, so that it is ruptured and one double layer is formed surrounding both particles. Inside this, molecular orientation sets in and as there is the normal tendency to decrease the surface the particles may coalesce and recrystallise as one crystal. The gelatin, by blocking rapidly growing faces by an adsorbed layer, and by the influence of its internal structure, gives uniformity of growth to the grains and discourages the large dendritic forms. Each grain of the emulsion retains an adsorbed layer of potassium bromide, in which the bromide ions are attached to the crystal lattice, while the

potassium and other counter ions cannot enter it. These therefore cling diffusely round the crystal at the other side of an electrical double layer and are displaceable by other ions of the same sign. As will appear presently, this electrical double layer is of importance in the theory of development, and even physically has important effects in the newly precipitated emulsion, preventing flocculation. The firmly held bromide ions give each crystal an electric charge, so that it repels similar crystals (peptisation). Silver halide precipitates prepared in the presence of an excess of silver nitrate have similarly a firmly held layer of silver ions, and are of opposite sign to these prepared in presence of excess potassium bromide. A mixture of the two precipitates therefore flocculates. Following Fajans and Frankenburger, the silver bromide prepared with adsorbed silver ion is known as the silver body, that prepared with adsorbed bromide ion as the bromide body. The bromide body alone can be used in photographic emulsions for development. Precipitates of opposite sign are reduced immediately by the developer without exposure to light and are also very rapidly discoloured by the action of light direct. Silver-body precipitates (usually of silver chloride and citrate) are therefore used in printing papers, in which a visible image is produced by the continued action of light, and then toned and fixed without development.

*The Grain and Grain-size Distribution.*—Under the high-power microscope the grains of a negative emulsion are found to be well-defined crystals of diameters ranging from the limit of resolution to some 3 $\mu$ . They generally belong to the octahedral class of the regular system although cubic forms are found. The actual shape of the crystal can vary enormously, depending on whether growth has taken place in one, two, or three dimensions. The first gives needles, the second plates, and the third prisms. All these variations may be considered to be derived from a regular octahedron by differential growth of the faces. The octahedral faces have all their exposed ions of the same sign, and therefore exert powerful electrical attraction on dissolved ions of opposite sign. It is supposed that the adsorption of such ions slows down their rate of growth normal to the face, with the consequence that the fast-growing cubic faces contract to a point or line. The plates which occur in such large numbers are oriented by the forces operating during the drying of the coated emulsion to lie predominantly with their planes parallel to that of the support, and consequently present the largest possible target to the incident light.

While all the considerations of this paragraph are subject to large qualifications which will appear in due course below, it is possible to discern on a theoretical basis the main effects of grain size and grain-size distribution on the photographic properties of the finished photographic material. These quantities are fixed at the ripening stage; the subsequent processes of washing, digestion, coating, and keeping do not disturb them significantly. Once ripening is stopped by washing, therefore, the possible photographic properties of the finished photo-

graphic emulsion are restricted. Thus we should expect that the fastest emulsions are those in which mean grain size is large. Whatever be the mechanism of the action of light, a large grain when reduced contributes more opacity to the photographic image than a small one, and it is difficult to believe that it requires proportionately more light. Similarly, provided that the number of quanta required to make a grain developable is not small, it would be expected that an emulsion in which all the grains were identical would have a high contrast. A certain exposure just insufficient to render a particular grain developable would not affect the others either. A slightly greater exposure will cause all the grains to be blackened. This is found broadly to be the case. Careful experiment with a series of emulsions, i.e., a comparable set of emulsions where all the chemical factors are the same and only the time of precipitation of the silver halide is varied (Trivelli and Smith, *Phot. J.* 1939, 79, 330, 463) showed a direct proportionality (a) between the Hurter and Driffield speed  $s^*$  and the average grain size, and (b) between the Hurter and Driffield speed and the time of precipitation of the silver halide, and an exponential relation between the contrast of the emulsion (expressed by the tangent of the angle of slope of the Hurter and Driffield characteristic curve, termed  $\gamma$ ) and the standard deviation ( $\sigma$ ) of the grain-size distribution. This is calculated from the formula

$$\sigma = \left\{ \frac{\sum x^2 y - \bar{x}^2 \bar{y}}{\sum y} \right\}^{1/2}$$

in which  $x$  is the grain size,  $\bar{x}$  the average grain size, and  $y$  the frequency observed per thousand grains.  $Z$  is zero if all the grains are identical.

The emulsion maker therefore is able, by suitable choice of the conditions of precipitation and ripening, to settle the general character of the finished emulsion. By very rapid precipitation and minimum ripening he obtains an emulsion of low speed, high contrast, and small grains nearly identical with their neighbours; by slow precipitation and maximum ripening in the presence of a silver halide solvent he produces an emulsion with a wide variation in grain sizes, a considerable proportion of which are large, and which has corresponding potentialities of high speed, but of only moderate contrast. He can further fix the total weight of silver per cubic centimetre of emulsion, which, for a given coating thickness, affects the contrast and the maximum density.

The determination of the grain-size frequency distribution of a photographic emulsion is a highly specialised laboratory technique. Most of the work on this subject has been done by direct measurement of photomicrographs, made at a magnification of 2,500 diameters and enlarged for measurement to 10,000 diameters. To avoid serious error, in studying the small-grain end of the distribution of the slower emulsions, the photomicrographs have to be made by ultra-violet light to obtain sufficient resolution, and even then the true size of the smallest class has to be obtained by extrapolation. Typical frequency curves for emulsions of increasing precipitation time are shown

• Defined In Section V, p. 9B6a.

in Fig. 1 (from Trivelli and Smith, *l.c.*). As precipitation time increases the curves become flatter and increasingly skew. It was shown by Sheppard and Trivelli that this is a result to be expected from the distribution of the velocities of ions and molecules in the reaction solution, which was shown by Maxwell to follow the normal Laplace-Gaussian probability law. The first sub-microscopic particles of precipitate will have velocities the distribution of which follows the same law. The particles grow proportionally with the number of collisions, which is proportional to their size at any time. The result is a skew-form distribution curve, which can be expressed by an equation

$$Y = Ax^n e^{-k(\log x - a)^2 \Delta x}$$

which is readily shown to be the normal distribution in terms of  $\log x$ . \* Here  $Y$  is the relative

frequency of grains in the size-class  $x$ ,  $A\%$  being the class width of the size units used in the measurements (e.g., 0.1 eq. if these measurements are made in terms of the projecting area of the grains in square microns). This formula has the unique property that  $n$  can be made any rational number by a mere change of the constants  $A$  and  $a$ , so that whether diameters, areas, volumes or weights of the grains are measured, the distribution law turns out to be the same.

In the more usual case with actual emulsions, the distribution curves are found to be composed of segments meeting at distinct discontinuities, each segment conforming to the above law. Such discontinuities are shown most plainly by plotting the accumulated frequencies (i.e., the sum of all the grains smaller than  $x$ , against  $x^*$ ) on semilogarithmic probability paper, the graph then being a representation of the

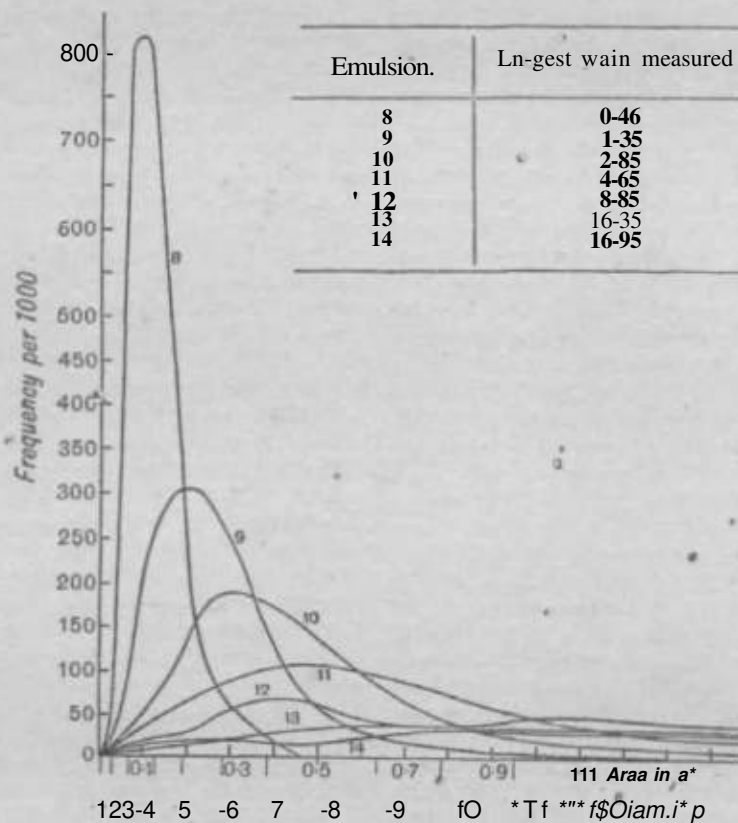

FIG. 1. SIZE FREQUENCY DISTRIBUTION OF SILVER HALIDE GRAINS IN EMULSIONS.

normal function of Kapteyn. Two or more straight lines meeting rather sharply are obtained. The formula above follows immediately from the fact that the graph of the normal function is a straight line. From the curves suitable frequency constants for the

\* Called log-normal distributions; see J. H. Gaddum, Nature, 1945, 156, 403.

† If a quantity  $x$  related to  $x$  by the function  $y = l(x)$ , can be found which is distributed according to the normal Gaussian error curve, then  $l(x)$  is called the normal function of  $x$ . The form of  $l(x)$  is a function of  $x$  in which the observed skew distribution of  $x$  was produced. If the normal function  $l(x)$  is logarithmic, e.g.,  $l(x) = (\log(x - a))$ , as in photographic emulsions, it indicates that the particles have grown at a rate proportional to their size at any instant.

emulsion are calculated; e.g., the average particle size, the dispersion (the standard deviation), the coefficient of variation, and the median. By multiplying the frequency at which the grains in each class occur by the size of the class, a new curve is obtained representing the relative contribution to the total protective area of the protective area of each size class of grains, a curve better related to the photographic properties of the emulsion than the straightforward frequency-distribution curve. The number of grains per cubic centimetre of the liquid emulsion is generally counted directly from a separate microscopical preparation. Typical values for commercial emulsions are given in Table I, quoted from C. E. K. Mees ("Theory of the

Photographic Process," Macmillan Co., New York, 1942, ? 52).

TABLE I.

Plate of film.	Average grain size, *, sq./x.	Dis-persion $\sigma, \mu, \rho,$	Number of grains, N, per c.c.
Motion-picture positive	*0.31	*0.25	117-85x10»
Fine-grain roll film	0.49	0.58	52.35x109
Portrait film	0.61	0.79	25.66x10'
High-speed roll film	0.93	0.81	22.61 x 10»
JT-Ray film . . .	2-30	103	6.32x10*

On tUb completion of ripening, the gelatin strength is Wrought up to approximately 10% by the addition of further gelatin, which is selected, however, in this case not for its mechanical and c%lloid protective properties but for its behaviour in the digestion stage. When all the added gelatin has dissolved, the emulsion is cooled as rapidly as possible and the firm jelly cut into shreds a few millimetres in diameter to facilitate washing.

*The Wash\$ng-out of the Soluble JSdlt.*—The emulsion is washed to remove the potassium nitrate, product of the precipitation reaction, and excess\*bromide or ammonia left from the ripening stage. One method is by the use of sprays of clean water impinging on the shredded emulsion spread out in perforated metal baskets. While this water must be filtered from suspended dirt and reasonably free from dissolved salts, it need not be distilled. This is fortunate in view of the very large quantities required. The extent of washing is controlled by the conditions of flow, temperature, and time, arid measured by analytical procedures which may be of an electrical nature.

*Digestion.*—If the emulsion at this stage is tested sensitometrically for its response to light it is found to be not only of low speed but of low contrast also. As it is held at a temperature of 50°c. or more, contrast and sensitivity increase very rapidly until, in a time usually less than an hour, the emulsion attains the contrast normal for its particular grain-size distribution. Speed may continue to increase for a time in a manner depending upon the whole previous history of the emulsion and of the gelatins used. After a time, usually less than an hour, the increase of speed ceases, and if digestion is continued the fog (i.e., the proportion of grains which are reducible in the developer without exposure) may begin to grow rapidly.

Present understanding of the changes which take place in a photographic emulsion during digestion is a product of the last 25 years. Practical emulsion-makers had learnt by experience that gelatins differed enormously in their influence on the photographic properties of the final emulsion, although they might be very similar in their properties of protective colloid in precipitation. Some gelatins are classed, on the basis of practical trials, as "slow" or "inert," others as "fast" or "active." After accurate statistical methods for discovering the grain-size distribution of emulsions had been developed, it became

apparent that the differences between gelatins could no longer be put down to their influence on this factor, but that a direct chemical explanation of their activity must be sought. A discovery made by R. F. Punnett, of the Kodak Park works, Eastman Kodak Co., that an extract could be prepared from an "active" gelatin, which increased the speed of emulsions made from inert gelatin, appeared to prove this. The result of a long investigation based on this broad clue appeared in a paper published by Sheppard in 1925 (Sheppard, Phot. J. 1925, 65, 380). Both by-products and intermediates from every stage of gelatin manufacture (u. Vol. V, 504a) were examined by exhaustive extractive procedures and photographic emulsion tests, this latter consisting in adding the extract in question to an emulsion made with a standard inert gelatin. It was found that the acid delimiting liquors contained an active material, which could be concentrated by evaporation *in vacuo* or better by ligroin extraction of a precipitate of aluminium hydroxide produced in the liquor by the addition of alum. The extract dried down to a reddish waxy solid consisting chiefly of cholesterol, but which was shown to be active because of a non-sterol impurity dissolved in it. Hi a search for this impurity, extracts were prepared from vegetable seeds, as being likely to contain a considerable sterol fraction, contaminated, moreover, with the same impurity, carried into the gelatin in the diet of the animal. From a large variety of plant materials, notably the seeds and seedhulls of beans, peas, and cereals, the unknown ^ensitiser was obtained, associated, though apparently only by solution, with the phytosterols. An extremely potent extract was obtained from black mustard seed and the sensitiser reasonably identified with allyl mustard oil or some similar compound. The complete identity was established by separating this compound directly from active gelatin and from the delimiting liquors by steam distillation, and confirming its effect in emulsions. The concentration in photographic gelatin varied from one to three parts in a million.

Further work with pure compounds showed that the effective grouping was the wothio-cyanate grouping  $R-N:C:S$ , the alkyl part of the molecule being replaceable with other radicles. Such sensitisers were effective only in the presence of alkali sufficient tq produce ammonia or free amino groups with which they react to form a thiourea.

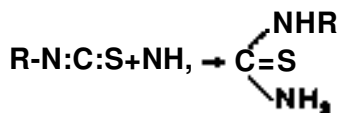

Traces of these substances in an emulsion, formed either from the naturally occurring thio-carbimides in the gelatin by the action of ammonia or amines, or deliberately added thioureas, attack the silver halide grains, forming small quantities of an addition compound:

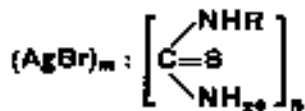



When this compound reacts with alkali it is converted into silver sulphide. The importance of this mechanism will appear in Section II, where it is shown to provide the necessary sensitivity specks required by modern theory to concentrate the action of light falling over the whole target area of each grain.

While the publication of the above work provided a considerable stimulus to research and explained some long known practical observations, it did not transform the art of emulsion making into a science overnight. Gelatin contains many other impurities besides the thiocarbimides, and some of these may have equally profound effects. Thus sulphide-ion sulphur in a gelatin is liable to give coloured dichroic fogs on long development of the finished material. The sulphide produces germs of silver sulphide throughout the gelatin when the layer is immersed in the developer. These grow during the remainder of development by a plating on to them of silver dissolved out of the layer by complex ion formation (*e.g.*, with the sulphite). When big enough to scatter blue light, they appear as yellow stain. Such sulphide sulphur can be estimated by measurement of the hydrogen sulphide formed on aeration of an acidified sample of the gelatin, or by the Feigl reaction with sodium azide.

Other compounds of sulphur in gelatin or an excess of the sensitisers may produce normal or black fog, *i.e.*, they make an unduly high proportion of grains developable without exposure. In addition, desensitisers and anti-fogging agents of unknown nature are undoubtedly present in small and varying amounts, so that the behaviour of a gelatin can, as before, only be ascertained by practical trial. Gelatins can be classified empirically into various classes by the photographic properties of emulsions made with them and tested at successive stages of the emulsion-making procedure. By such classifications the emulsion maker is able to maintain the properties of his emulsions through changes of gelatin from batch to batch, a necessity of commercial production where the market expects a given grade of the product to have the same properties regardless of batch number.

The emulsion so made is run off through coolers into emulsion pots, set, and stored in a refrigerated room. It may be used as the basic emulsion for a variety of products, depending on the sensitising dyes and other "doctors" added. Before coating, the pH and pAg are adjusted, hardeners and stabilisers added, while "doctors" to assist spreading and break foam may be added expressly to assist the coating operation. From an early stage the emulsion must be preserved against the action of bacteria and moulds by the addition of selected preservatives. Throughout these processes the use of silver-lined kettles, and vessels of chemical stoneware, stainless steel, or of nickel, is common practice.

While the above description would make it appear that the preparation of a photographic emulsion is by no means a difficult chemical operation, in commercial practice the need of consistency transforms an essentially simple chemical operation into a process requiring refined chemical and sensitometric control at

every step. A large part of the product of the industry is used in mechanised applications where it is extremely inconvenient to change the strength of light sources or the time of development to suit a change in the properties of the photographic material from batch to batch of the same grade. In the cinematograph industry, in particular, a difference of as little as 12% in the speed of adjacent rolls of the film on which positive prints are made would be detectable on the print. The mechanics of the quantity production of such prints are such that adjustments to cope with the differences of 50% and more which were common 20 years ago would often be outside the range of adjustment physically provided for in the apparatus, even if the industry were prepared to put up with the expense and interruption required first to find the extent of the adjustments and then to put them into effect. The manufacturers therefore, faced with a constant inflow of new batches of raw materials, one of the most important of which, gelatin, is a natural product which as yet can be made to conform only to a limited chemical specification, is forced to use the devices of pilot coatings and of blending both of gelatins and of finished emulsions in order to obtain a consistent product. The organisation of the testing procedures required and their integration with production, results in a high proportion of testing to production personnel, as compared with other industries. This proportion may amount to 25% if the staff engaged on inspection and testing of the finished product is included.

Printing Paper Emulsions.—In printing papers the main division is between enlarging and contact papers. The emulsion maker has to pay much more attention to image colour and ease of handling under mass-production conditions, and can, except for the division above, neglect comparatively the question of absolute speed. Once suitable levels of speed in these two divisions have been established, his aim, particularly since the advent of printers with automatically controlled exposure, is to produce batch after batch of a consistent product. For enlarging papers the main resource is a washed silver bromide emulsion of the slow negative type, either completely unsensitised or sensitised only in the blue or blue-green region of the spectrum. All such papers are invariably handled in orange or red light. The "gaslight" paper, used for contact printing of amateur negatives in "D. and P." establishments, has a silver chloride emulsion slow enough to be handled in a bright yellow light, yet fast enough to yield a satisfactory print in a commercial printer with an exposure of the order of one second. It yields a characteristic blue black image colour and a gradation of tones peculiarly well adapted to modern negative materials. In between the two are the chloro-bromide paper emulsions, the usefulness of which depends upon the range of pleasing warm-black tones obtainable by modifications of the conditions of development. These are, as their name implies, mixtures of silver bromide and chloride coprecipitated to form mixed crystals, the isomorphous bromide and chloride crystallising together to yield one lattice. They can be made



of speeds suitable either for enlarging or for contact printing. The grains of such chloride papers are only visible under the highest powers of the microscope. In their preparation the well-defined stages in the preparation of negative emulsions do not appear, the quality and sensitivity of such emulsions depending upon the formula, the gelatin (most or all of which is added at the beginning), and the exact conditions of precipitation. Variations in these factors allow each kind of paper to be made in grades giving satisfactory prints with a full scale of tones from white to black from negatives of widely differing density range. This question of the exposure scale of the paper is dealt with in Section V. In recent years a number of papers have appeared in which the exposure scale can be selected at the time of printing by choice of the colour of the printing light. This is done either by a mixture of two emulsions of differing contrast differentially sensitised (8.P. 494088, 1937; 541510-15, 1940) or by the use of certain sensitising dyes in very limited amount (B.P. 547060, 1940).

**The Ravy Materials.**—The silver nitrate used for emulsion making is made from bullion silver and is purified by repeated recrystallisation. It must be free from other heavy metals and organic dirt, but satisfactory purity is not difficult to achieve. The gelatin used in photography is the highest quality product made by gelatin and glue works. While the essential treatment of the raw material is as described in the article GELATIN (Vol. V, 504, 505), the stock is selected, and only the products of the early and lower-temperature cooks are employed for photographic gelatin. The selected stock includes clippings from calf hide, and ears, cheek pieces and pates, these parts being of no value for leather. Certain qualities of gelatin are made from pigskin, and some from decalcified bone. Lime-processed and acid-processed gelatins are both used. These differ in their isoelectric point, which is a function of the extraction history of the material with respect to pH (Ames, J.S.C.I. 1944, 63, 200) and in the properties of the jelly (*e.g.*, swelling behaviour).

In choosing the gelatins, the emulsion maker is concerned almost equally with the physical properties of the jelly prepared by cooling hot solutions of the gelatin as with its chemical reactions with the light sensitive silver halide. For the first, laboratory tests of jelly strength, viscosity before and after digestion, melting-point, and particularly rate of setting provide sufficient criteria of selection. For the second, the laboratory can test for the presence of heavy metals and reducing agents (both to be avoided), and can put the gelatin approximately into its class as to its potentialities for giving speed by estimations of the labile sulphur carried out according to some standardised technique. The only satisfactory method, however, is by the preparation of pilot photographic emulsions, the properties of which, interpreted by the aid of a vast body of experience, enable any particular gelatin to be classified and earmarked for an employment where its good qualities will best be utilised and its defects be least harmful.

To a limited extent the emulsion chemist is

able to modify both the physical and chemical properties of the gelatin raw material. To the first belong all those procedures described as hardening. Such procedures are commonly applied at two points in the history of a photographic material, namely during manufacture where hardening is used to give protection against softening and sticking at high temperatures and humidities, and particularly in the case of photographic papers, to allow of simultaneous drying and glazing of the prints on a hot polished metal drum; and also during processing to keep the wet gelatin layer firm and tough throughout the processing operations, particularly if these are to be carried out at temperatures higher than normal. The reactions involved are similar to those operating in the tanning of hide. Inorganic agents used are chrome alum and potash alum, the latter being used very extensively in acid hardening fixing baths. These salts harden to an optimum at a characteristic pH at which hydrous alumina and chromic oxide start to separate; pH 4.0 for aluminium and pH 5.1 for chromium, though the exact value varies with the conditions. The alums can thus be used in acid solution, as in acid fixing baths. Organic hardening agents, on the other hand, in general increase in efficiency as the pH is raised above pH 5, approximately the isoelectric point of lime-processed gelatin. The agents used, many of which are protected by patents, may be classified as aldehydes (*e.g.*, formaldehyde), hydroxyaldehydes (*e.g.*, glycol aldehyde, aldol, glyceraldehyde), dialdehydes (*e.g.*, glyoxal), unsaturated aliphatic aldehydes (*e.g.*, acrolein, crotonaldehyde), carboxylic aldehydes (*e.g.*, mucochloric acid), ketones (*e.g.*, diacetyl, acetylacetone). Some of these agents are liable to cause fog, others reticulation (this is a fine-grained folding of the emulsion layer into a network of waves, often due to excessive swelling of certain strata of an emulsion layer combined with hardening of other strata).

The chemical properties of gelatin in relation to emulsion making are, as described above, mostly taken as found. Nevertheless agents are known which, when added to a gelatin, cause it to behave photographically like one of a different class. Such agents can modify both the dispersion of the silver halide precipitate and the manner of the formation of sensitivity specks on it. Defects such as liability to yellow stain or to yield high veil on keeping can also be reduced. The nature of these agents, in so far as it has been made public, is to be sought in the patent literature (*e.g.*, B.P. 539355; 536525; 522997; 516005; 541232; U.S.P. 2271622; 2271623).

The potassium bromide, iodide, etc., used are the ordinary chemicals of reagent grade. The dyes used for conferring sensitivity to coloured light are discussed in Section VII.

**The Coating Operation.**—The gelatin medium universally used as the vehicle for silver halide photographic emulsions has so many useful properties both from the manufacturer's and the user's point of view that its few defects are accepted as necessary evils and countered by suitable procedures both in the factory and in the darkroom. The ready reversibility of the sol-gel transformation, which may prove a

nuisance to the photographer attempting to process his materials in the tropics, is an asset in the coating room, as it enables the fluid emulsion, cast evenly on a support, to be set rapidly by refrigeration to a jelly which can then be dried during a comparatively much longer period without disturbance to the original form of the coating. Moreover, the support with the set jelly on it can be handled without regard to gravity, capillarity or other factors which would gravely complicate the drying of a liquid layer. The coating of photographic emulsions can therefore be considered in two stages: (a) the coating of the emulsion on the support and its setting; and (b) the drying of the set layer.

In dealing with the first, the techniques employed naturally differ according as to whether the support for the emulsion is flexible or rigid. All materials of the former type are handled in the form of rolls, some 40 in. wide, and the machinery is designed to take a roll of raw support at one end, and deliver a roll of coated photographic material at the other, the coatings applied not necessarily being confined to one. Summarising a description which has appeared in the article CELLUXOID PLASTICS {Vol. II, 446a), the support is unwound from the stock roll (Fig. 2) over a number of rollers, one of

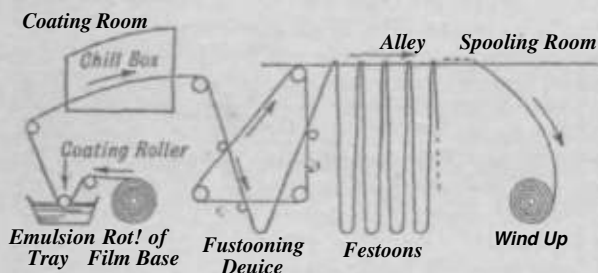

FIG. 2.—DIAGRAM OF FILM EMULSION COATING PLANT.

which may be connected to a footage meter, to the coating roller, round which it is bent through approximately 180° to rise vertically some 10 or 12 ft. into the chill box. The coating roller dips into the liquid emulsion which is fed by a constant level device to the water-jacketed coating tray, which can be adjusted as to height by a precision jack. Cups at each end of the coating roller bear on the support at its edges and prevent leakage of emulsion round to the wrong side of the support. In the chill box the emulsion is set by blasts of cold air directed on to the face of the material, or by a combination of this with the cooling action of a chilled roller coming into contact with the back.

With this arrangement the amount of emulsion picked up and thus the final thickness of the dried layer depends solely on the viscosity of the emulsion and the speed of the machine. The conditions are the same as those employed in the manufacture of enamel-covered instrument wire, where it has been shown (G.E.C. Research Staff, Phil. Mag. 1922, 44, 1002-1014) that the outer face of the equilibrium fluid layer is stationary while the inner is moving upwards with the velocity of the support. In the simpler case of a plane surface, this leads to a formula

connecting the viscosity  $\eta$ , the density  $\rho$  of the emulsion, the speed of the coating machine, and the thickness  $t$  of the layer as follows:

$$t = 2v\eta/\rho g \text{ where } v \text{ is the velocity of drawing.}$$

It will be seen that as the speed of the machine and the viscosity of the fluid layer increase, so does the thickness of the congealed layer. Hence there is a limit to the speed of coating, a speed where no practicable reduction of the viscosity of the emulsion by dilution or high temperatures will yield a sufficiently thin coating. In general the viscosity of the emulsion can be reduced sufficiently by dilution and by control of the temperature (for a fine adjustment) to give the thickness of coating required at speeds from 15 ft. per min. upwards. Given a support without dimples or cockles, the uniformity of coating which can be achieved by this method is extraordinary. Rolls 2,000 ft. long can be coated, and processed to a positive by reversal (Section III, p. 563c) Without any of the effects of non-uniform coating being detectable photographically. In reversal the positive image is developed from all or part of the residual halide image left after removal of the negative silver image in a bleach. Its density is particularly sensitive to coating thickness variations. It is

doubtful if the integral tri-pack materials for colour photography (see Section VII) could have been brought to a commercial success in the absence of this prior art of uniform coating of film with black and white emulsions. A far lower degree of uniformity is achieved on paper, where the surface of the sheet is not plane. Except for reversal processing, however, a non-uniform coat does not matter, within limits. The image only reaches the support in the deepest shadows (where non-uniformities cannot be seen) and elsewhere extends to its proper depth in both hump and hollow, the excess of silver halide being dissolved away in the fixing bath. Nevertheless, as uniform a coating as possible is desirable as thick and thin places have different rates of drying which may alter the sensitivity and produce a mottle. Normal variations do not exceed 5% (i.e., 0.4% on the dry layer).

The coated material, after the emulsion is set, emerges from the chill box, and may either have another coat put on it immediately or is first dried. The application of a thin anti-abrasion supercoat of plain gelatin, usual on all products except perforated motion-picture film, is common at this stage. The supercoat is quickly set by chilled rollers applied to the already cold material, and the whole then dried under carefully controlled conditions in very clean air.

For drying two methods are in use. The first utilises the usual method of festoon drying of the paper-coating industry. The material as it emerges is picked up on sticks which are brought into contact with the back by projections on two parallel rising chains, one at each side (Fig. 2). The festoons formed are from 7 to 9 ft. deep. The stick is transferred at the top of the rise to a horizontal slower-moving chain which conveys the sticks and the loops bodily through the length of a drying alley, which may be up to

300 yards lojig. Here the water in the swollen layer is evaporated by air currents controlled as to direction and volume by adjustable ports and as to temperature and humidity by air conditioning plant. All the air is filtered to clean it of dirt. The air temperature gradually rises through the length of the alley, but just before spooling the temperature falls and the humidity rises to condition the product for spooling and packing. Machines of the mother type which grip the material by the edges and carry it > through a drying tunnel have\* the advantage that the product can be coated on both sides and dried in one operation. With festoon drying the back of the product, which may carry another photographic emulsion (X-ray *Mm*), or a gelatin\* anti-curl or anti-halation layer (amateur roll film), has to be coated in a separate operation, with the material turned over.

The commercial coating of glass plates is a completely distinct technique with a much longer history. The operation *hSre* is one of spreading, no control being possible by drainage. The glass plates, which are selected from window-glass production for flatness and freedom from flaws, are washed on a machine by sprays and reciprocating brushes, rinsed, and then coated with a substratum before passing down a drying tunnel. The subbing solution, which is a very dilute solution of gelatin and hardening agents, is conveniently applied by a wick wiping the face of the moving plate. When dry, the substratum can just be detected by rubbing it up under the microscope. It serves to anchor the emulsion to the glass and prevents edge frilling and blisters during processing. «The clean, dry, and subbed plates are now ready for coating, but may be backed first, if the backings will withstand the subsequent coating operations. Modern plates are frequently backed with a coloured (or black) layer, which dissolves off the glass in the processing baths. In the more successful examples the dye removed with the dissolving backing is decolorised in the developer. In the camera the backing layer, which has a refractive index close to that of the glass, prevents reflection of light at the back face of the glass and absorbs that which crosses it, reducing the defect known as halation. Alkali soluble vehicles which have been used comprise phthalate esters of cellulose and poly vinyl alcohol, and hydrolysis products of natural resins (B.P. 552135; 520157; 511180). Where the plates are backed after coating the vehicle can be any water-soluble gum (*e.g.*, gum arabic). Backing before coating is more convenient and controllable than backing after coating, as the operation can be done in the light, and the rejection of defective plates is not so costly. On the other hand, with this method the backing layer must be water resistant to withstand contact with the wet bands of the coating machine, yet readily soluble in the mildly alkaline developer. The other necessary properties of firm adhesion, ready parting under the diamond without chipping, and lack of tack when stored under tropical conditions, all limit seriously the range of possible vehicles. The dyes (*e.g.*, Acid Fuchsin, Ink Blue) are discharged by the alkali or sulphite

of the developer. Dyes with less desensitising powers than the above triphenylmethane dyes are disclosed in the patent literature (B.P. 506385; 529440).

The coating with emulsion is done by spreaders which discharge a carefully regulated amount of fluid emulsion on to the horizontal surface of the plate travelling on a moving band, or on chains. A few seconds after coating the plate is transferred to a chilled band which sets the emulsion, this band moving slightly faster than the coating band so as to separate the plates. Setting is completed by the time the plate reaches the end of the band, and the plates are then removed and racked for drying in cupboards. The air supplied to the cupboards is filtered, washed, and conditioned just as it is for the drying alleys of flexible products.

Spreaders are of various designs, each factory having its own pattern modified by experience to suit its own peculiar conditions. In three types the emulsion is delivered to the plate from a constant head device by gravity alone; these are the parallel plate spreader, the slit spreader, and the weir spreader. In the first, two parallel plates slightly spaced from each other form a slot through which a steady stream of fluid emulsion is fed to the moving plates. In the second the slot is reduced to a slit, while in the third the liquid emulsion overflows from a constant head device down one or more weirs. Each weir crest forms a delay stage at which lengthwise evening-out of the emulsion can occur. A fourth type attempts to secure even coating by the same principle as is used for flexible products. A rotating roller picks up a film of emulsion which is removed by a rubber scraper and guided down a weir on to the plate. In most cases coating is actually done from a meniscus formed at the junction between the moving plate and a light flexible apron attached to the spreader. At the point of coating the coating band passes over a carefully levelled coating bed, and the whole is kept above the setting point of the emulsion by passing the coating band through a tank of hot water. The glass plates, which are put on in edge to edge contact, are rapidly and evenly heated by the film of water on which they rest. Even after coating, therefore, the emulsion can level itself up until set by transfer to the similar wet chilling-band.

No account of coating procedures for photographic materials would be complete without mention of the extraordinary precautions which have to be taken throughout to eliminate defects due to microscopic particles of foreign dirt. Once the layer is set, any foreign body already in the layer or reaching it during coating or drying! if capable of affecting the photographic properties of the emulsion at all, will reveal itself by a dark or light spot which may have an area five hundred times that of the foreign particle itself. Dirt specks, therefore, which are invisible except under the microscope may produce a crop of blemishes sufficient to ruin the photograph even on naked-eye inspection, to say nothing of enlargement in the cinematograph projector. Particles of metal from machinery, soil, sulphur from rubber goods, mercury, all

have very potent effects. Operatives are required, therefore, to wear special overalls, caps, and in some operations gloves, while plant and buildings must be maintained in a state of spot-less cleanliness comparable with that in a surgical operating theatre. The same precautions must be taken in the packing rooms, where dust reaching the face of the product will obstruct the light when the material is exposed and lead to a crop of minute white shadows knowiras dust specks. The packing materials must not only be free of dust, but carefully selected on the basis of practical trials in contact with photographic emulsions incubated with them in sandwich form.

**Supports for Photographic Emulsions.**—The varieties and manufacture of photographic film support are described in the article CELLULOID PLASTICS (Vol. II, 446). For the manufacture of sheet window glass see Vol. V, 590, 594. While the main principles of the manufacture of photographic paper do not differ from those applied in the manufacture of any high-class book or writing paper (v. this Vol., p. 215*d*) the requirements are so specialised that manufacture is in many cases relegated to a special mill devoted entirely to photographic paper. This is mainly because of the extreme precautions which have to be taken against metal speck impurities, which would give rise to spots on the finished photographs. The papers produced are characterised by high chemical purity, whiteness, and strength, particular importance being attached to wet strength, so that the prints shall stand up to the processing operations. The fibre stocks used comprise rag, bleached sulphite pulp (hard and soft wood); bleached alpha pulps (hard and soft wood); bleached soda pulp (hardwood); esparto. Whereas 20 years ago the inclusion of a large proportion of rag would have been considered essential for the necessary strength and permanency, the art has so improved that to-day papers made wholly of wood can be superior to rag papers made from laundered rags. This applies particularly to the alpha pulps. The weights used range from 70 to 250 g. per sq. m., the last being card stock. Apart from the rosin size incorporated in the beater, the papers are usually tub-sized with gelatin, and may be coated directly with emulsion (magnesium surfaced papers) or are more usually baryta coated in a separate department. The baryta coating, which is based on blanc-fixe in a gelatin binder, determines the nature of the paper surface; i.e., whether glossy, satin or matt, and can be dyed to give popular shades of blue-white or cream. From one to four successive coats are applied, the machinery and festoon drying technique being that usual in the paper-coating industry. The coated papers are calendered before emulsion coating, and one of the bowls may be embossed with a fine-grain pattern to confer a distinctive surface. Further matting agents (e.g., starch) may be added to the emulsion and supercoat. Photographic papers are invariably overcoated with a thin plain gelatin supercoat to avoid stress marks, i.e., lines of developed silver along the course of abrasions.

A small proportion of photographic material is coated on special supports. These include aluminium foil, which may be anodised, lacquered, or laminated between two sheets of paper in order to insulate the emulsion from the metal. This material retains its dimensions throughout processing very closely. Other paper supports are waterproofed before coating by the application of lacquers to both sides. These are quickly processed and dried and have good dimensional stability. Semi-transparent supports of glassine, transparentised and lacquered paper, and tracing linen, when coated with a slow emulsion, have their uses in the drawing office. Various products in which the emulsion layer can be stripped off after processing, mounted on a thin film of collodion or an unsensitised gelatin layer, are used in the photomechanical industry. The materials so produced yield negatives with many of the uses of negatives on film, but at a lower price. In these products the interface of stripping is treated with traces of wax or resins to ensure a clean separation when the stripping layer is later detached. Others depend on the solution of a layer of soft gelatin in warm water.

#### THE HISTORY OF PHOTOGRAPHIC MATERIALS.

The modern photographic process with salts of silver, in which an indefinite number of prints can be made from one photographic negative, derives in a direct line from the work of William Henry Fox Talbot (1800-77), who in 1834, in ignorance of previous work reported by H. Davy and Thomas Wedgwood in 1802 ("An Account of a Method of Copying Paintings upon Glass, and of making Profiles by the agency of Light upon the Nitrate of Silver." Invented by Thomas Wedgwood, Esq., with observations by H. Davy, *Journal of the Royal Institution*, 1802) began experiments specifically directed to fixing the image of the camera obscura. He began with white paper brushed over with nitrate of silver, but found it, and a like paper treated with silver chloride, intolerably slow for use in the camera. He attempted an improvement by forming the silver chloride on the paper by alternate baths of salt and silver nitrate, and succeeded, by using an insufficiency of salt to react with all the silver, and by exposing the paper while wet, in reducing the exposure to 10 minutes or so, provided it was a bright day. This was in the summer of 1835, when his first photographs, fixed by bathing in solutions of common salt or of potassium iodide, were obtained. These were of miniature size, and were negatives. They were of course print-out images. Talbot did not discover the latent image, and the process of its development, until September, 1840.

Talbot was led to publish his progress with print-out images in January, 1839, as a result of the announcement by Arago, on January 7, 1839, to the French Academy of Sciences (*Compt. rend.* 1839, 8, 4) that L. J. M. Daguerre had discovered a method of photography. This announcement revealed no details of Daguerre's process, which were not made public until August, 1839. Daguerre's process, which pro-

duced an enormous sensation, employed for the first time a method of development of an invisible latent image. Highly polished plates of silver, or of silvered copper were exposed to the fumes of iodine, and the sensitive surface of silver iodide exposed in the camera for from 3 to 30 minutes. The plate was then removed and the invisible latent image developed by exposing the plate to the vapour of heated mercury, which condensed on the exposed parts. Originally the plate was (imperfectly) fixed by means of a hot solution of common salt, but in 1839 Daguerre learnt of the solvent action of sodium thiosulphate solutions for the silver halides (reported by Herschel in 1819). In the Daguerreotype the image was reversed (as in a mirror), while the shadows of the subject were represented by the original silver plate, an image appeared dark only if so tilted as to reflect a dark part of the surroundings. The lights of the picture, made up of the mercury amalgam, could be damaged by a touch. The plate was considerably increased in speed by the use of bromine in conjunction with iodine (J. F. Goddard, 1840), and improved in contrast and resistance to handling by toning with gold (St. L. Fizeau, 1840). These improvements, together with the Petzval lens (1841) made portraiture practical. The possible part played in the final Daguerreotype process by hints learnt from the work of J. N. Niepce, Daguerre's collaborator from 1829 to his death in 1833, will probably never be known. He seems by 1816 to have got as far as Wedgwood had 20 years previously (unfixed negative prints on silver chloride paper), but abandoned silver processes for extremely slow processes based on the hardening of asphaltum varnishes by light. Some of these were spread on silver plates and his use of iodine to darken the bare metal left after removal of the unexposed varnish may have given a hint to Daguerre.

Daguerreotype, though extinct in 15 years, popularised the notion of photography and enormously stimulated research. By 1841 Talbot had produced the Galotype process, in which paper impregnated with silver iodide was washed over with a mixture of silver nitrate and gallic acid, and after exposure developed with more of the gallic acid and silver nitrate mixture. The resulting negatives were fixed in "hypo," and printed on the silver chloride paper of 1839. Talbot had learnt of the fixing powers of sodium thiosulphate solutions from Herschel, and may have used gallic acid as a result of hearing of its use in 1836-37 by the Rev. J. B. Reade. This experimenter had prepared what he believed to be a very rapid print-out paper by the use of gallic acid (inferred to be useful from the remarks of Davy in the paper of 1802) and used it in his solar microscope. He was in fact exposing and developing simultaneously, but did not appreciate the fact. Talbot, on the other hand, was fully aware, from results first obtained by accident on September 20, 1840, that he was developing a latent image. From his process, via albumenised glass (Niepce de Saint-Victor, 1847), wet collodion (F. Scott Archer, 1848-51), "preserved" or dry collodion (1860-70), to the gelatin dry plate (R. L. Maddox, 1871), modern sensitive layers derive.

## II. THE ACTION OF LIGHT.

Historically, the use of silver salts in photography followed from observations of the print-out effect. The useful processes which secured visible images by the development of invisible latent images produced by a very small exposure to light followed from successive direct modifications of print-out processes. From the early days of scientific interest in photography, therefore, it has been taken as probable that the events which produce a visible discoloration in a silver halide crystal on exposure to light are a continuation of the events which produce a latent image, and that this once produced, the mechanism of its catalytic action in enabling the developer to distinguish between an exposed and an unexposed grain belongs properly to a theory of development.

The nature of the print-out discoloration was for long not understood. As early as 1802, Davy, in commenting upon the experiments of Wedgwood with print-out silver chloride papers, opined that some of the silver deserted its acid to yield a dark compound with the organic matter present. Carey Lea, as a result of researches on the photohalides of silver, believed that the product of photolysis was a subhalide of silver, and that the latent image was formed of subhalide dispersed colloiddally in unchanged silver halide (Amer. J. Sci. 1887, [lii], 83, 349). While the existence of a subfluoride of silver was later demonstrated by Guntz (Compt. rend. 1890, 110, 1337), modern work with the microbalance by Hartung (J.C.S. 1924, 125, 2198) and with the X-ray diffraction camera by Koch and Vogler (Ann. Physik, 1925, [v], 77, 495) has shown conclusively that the product of photolysis of silver bromide and chloride on prolonged exposure to light is metallic silver and atomic or molecular halogen. Observations with the electron microscope, as also the spectral absorption of large crystals in which a new absorption band has been induced by exposure to light (Hilsch and Pohl, Z. Physik, 1930, 64, 606) show that, in contradistinction to the free metal which can be introduced into crystals of the alkali halides, and which is atomically dispersed, the silver making up the visible image on light-discoloured silver halide crystals is dispersed as a limited number of small specks. By analogy there is every reason to believe that the latent image produced by brief exposure to light consists similarly of aggregates of metallic silver, though of much smaller dimensions. The rest of this section, therefore, is devoted to accounts of the attempts made to prove this identity by indirect means, and of the currently accepted theory advanced to explain the primary action of light in producing such aggregates, together with the consequences of the theory which have been confirmed by experiment.

No direct method of analysis, nor any experiments with the electron microscope or with the X-ray diffraction camera, have succeeded in revealing the presence of colloidal silver in silver halide grains which have received an exposure to light of the order of that required to produce a latent photographic image. Development alone is able to reveal the latent image so that all the evidence regarding its distribution and

nature is necessarily indirect. With regard to its distribution, use has been made of an observation by Hodgson (J. Franklin Inst. 1917, **184**, 705), that if development was interrupted shortly before a visible image appeared, and the partially developed grains examined with a high-power microscope, then black specks were visible in or on the grain, becoming larger the longer the time of development before inspection. They were evidently the points, on the grain where development was initiated, and became known as development centres. Svedberg (Phot. J. 1922, **62**, 310), found that the centres were distributed over the grains according to the laws of chance, and that no centres appeared inside the grains (even for the X-ray exposures which he used). Since a grain becomes completely developable if it contains only one centre, this was advanced as a reason for the finding that the large grains are more sensitive than the smaller, as the probability that a centre will form is proportional to the surface area of the grain. Toy (Phil. Mag. 1922, [viii], **44**, 352) also found that the large grains were more sensitive than the small grains. A discussion which ensued as to whether the chance distribution of development centres was due to the chance incidence of light quanta was settled by Clark (Brit. J. Phot. 1922, **69**, 462), who demonstrated a complete parallelism between the production of developability by light and by treatment with sodium arsenite solutions, the parallelism extending even to the topography of the distribution of the development centres on the edges and faces of the crystal. It was suggested that the sites of the development centres were determined even before exposure by pre-existent *sensitivity specks* which either light or sodium arsenite changed into a form capable of catalysing development. Indirect experiments on the nature of the postulated sensitivity substance showed it to be much more resistant to chromic-acid solutions than was the latent image produced from it by exposing the silver halide crystal to light (Clark, Phot. J. 1924, **64**, 91). This was a deduction from the experimental fact that the speed of the emulsion "after chromic-acid treatment was much lower in the case where it had first had a pro-exposure to light (to change the sensitivity substance into latent image substance). Its nature, however, remained unknown. The modern explanation of these experimental facts is described below (p. 559b) when dealing with the Albert reversal.

An identification of the sensitivity specks with the ultra-microscopic specks of silver sulphide presumably produced on the grains by the decomposition of the addition compound with impurity thioureas from the gelatin (p. 549c) was made by Sheppard in 1925. With Trivelli and J. Tightman (*ibid.* 1927, **67**, 281), he showed by successive photomicrographs the production of specks of silver sulphide on the grains of a photographic emulsion which had been bathed in 0.01% allylthiourea solution and then treated with alkali. The sulphide specks were produced at the same points on the grains as first showed specks of the molecular addition compound, a point confirmed by the work of Hudson (J. Amer. Chem. Soc. 1927, **49**, 1814) on the macro scale

with a fused mass of silver bromide suspended in allylthiourea solution. The speckwise production of the addition compound was shown to be due to the autocatalytic nature of the reaction (Carroll and Hubbard, J. Res. Nat. Bur. Stand. 1934, **12**, 329).

The existence of development centres, and the postulated pre-existence of sensitivity specks at the same sites, still left unexplained the primary action of light. Indeed, a fundamental contradiction emerged if the sensitivity specks were considered to play any direct part in the absorption of light, since they could not be shown to have any influence on the spectral sensitivity of the silver bromide. The number of development centres produced by exposures to three selected lines of the mercury arc spectrum (Toy and Edgerton, Phil. Mag. 1924, [viii], **48**, 947) was found to correspond to that calculated from the spectral absorption of silver bromide; while plates from which the sensitivity specks had been removed chemically were found to have precisely the same relative spectral sensitivity as before, a spectral sensitivity which corresponded approximately with the spectral absorption of gelatino-silver bromide (S. L. Sheppard, 1925). From this it was concluded that the light was absorbed by, and was active in, the silver bromide crystal as a whole, but that the silver atoms reduced by the light were concentrated by the sensitivity specks to yield the discrete latent image specks. This famous concentration speck theory (Sheppard, Trivelli, and Loveland, J. Franklin Inst. 1925, **200**, 51) has been placed on a sound theoretical basis by the development of the quantum mechanics of the crystal state in the succeeding 20 years. The mechanisms proposed in 1925 and the immediately succeeding years were merely ingenious speculations, none of which gained general acceptance. A new starting point for the problem of the latent image followed from the treatment of the conduction of electricity in metals on the basis of the Fermi-Dirac statistics (Sommerfeld, 1928; Bloch, 1928, 1930). This proved highly successful and led to the application of the same ideas to non-metallic crystals in an effort to explain the properties of insulators and semi-conductors (Wilson, 1931). According to this picture of the crystal state, the electronic properties are to be ascribed to the crystal as a whole. A potential energy diagram can be drawn for a hypothetical one dimensional lattice of the ionic type (such as silver bromide or potassium chloride) and appears as in Fig. 3. The discrete energy levels which alone can be occupied by an electron in a single isolated atom are found to have been broadened into bands by the fact of the association of the atoms with their neighbours in a close periodically varying potential lattice. Two atoms brought near together are found, according to the equations of wave mechanics, to result in a splitting of each original discrete energy level into two closely adjacent levels, an effect due to the wave-mechanical probability of an electron jumping through the potential barrier between the adjacent atoms. In a crystal of  $N$  atoms arrayed together the multiplicity of the levels becomes  $2N$ -fold and may be considered as con-



tinuously distributed in distinct energy bands. Their power of accommodating electrons, however, is limited to  $N$  times the number of electrons that could be accommodated in the corresponding discrete energy level of the isolated atom. If a band is completely full, the electrons in that band are unable to move under the influence of an applied electric field: if it is empty, it can contribute nothing to the conductivity. In the silver bromide crystal the association of the ions in the lattice is due to the transfer of the  $5s$  valency electron of the silver atom to the vacancy in the  $4p$  shell of the bromine atom. In the crystal as a whole, therefore, at the absolute zero of temperature, the energy band corresponding to the  $5s$  level of the silver atoms is empty, while the  $4p$  energy band of the bromine lattice is completely full. The crystal is an insulator. Electrons transferred to the higher energy band by any means, heat or light, render the crystal conducting. Only light of sufficient quantum energy to raise an electron from the lower to the upper band is capable of producing photoconductance. This accounts for the spectral absorption bands of the silver (and alkali) halides, their transparency,

on the other hand, being due to the disallowed zones. In order to account for the permanent effects of radiation, however, it is necessary to assume (as was done by Wilson to explain the properties of semiconductors) the existence of traps, due to localised energy levels  $AB, CD$ , due either to the electron levels of impurity atoms or to irregularities in the lattice due to minute cracks or discontinuities in the crystal, one special case of such discontinuity being the outer faces of the crystal (I. Tamm, *Physikal. Z. Sovietunion*, 1932, 1, 722). These localised levels, if full, can furnish electrons into the upper conduction band by the aid of quanta of less energy than would be required to raise electrons all the way from the lower band; if empty, they act as electron traps. Electrons moving in the conduction band fall down the potential hill into the trap, and will be stable there unless lifted by thermal agitation or radiation of the right quantum energy into the conduction band again.

The coloration of alkali halide crystals by ultra-violet light, as also the photographic latent image, was ascribed to this trapping of electrons in localised energy levels in the disallowed zones

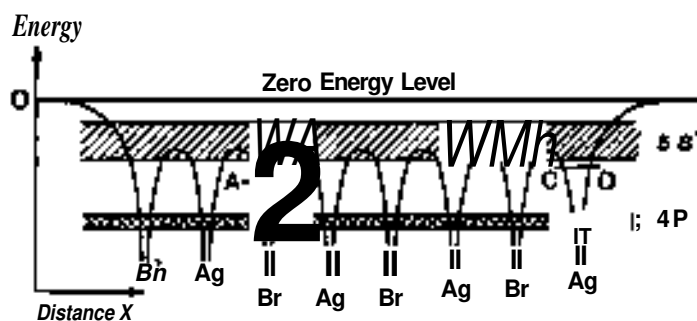

FIG. 3.—ENERGY DIAGRAM OF IONIC CRYSTAL OF AgBr TYPE, SHOWING ALLOWED AND DISALLOWED ZONES.

of the crystal by Gurney in 1933 (*Proc. Roy. Soc.* 1933, A, 141, 209). The idea was developed by Webb for the specific case of the silver bromide grain of the photographic emulsion (*Phot. J.* 1937, 77, 142), but it was not until the insertion of the further idea of an electrolytic current succeeding the primary photo-electric current (Gurney and Mott, *Proc. Roy. Soc.* 1938, A, 164, 151) that the theoretical conceptions became adequate to explain the known facts. The modern theory, which has been described in detail by Berg (*Trans. Faraday Soc.* 1943, 39, 115; *Reports of Progress in Physics*, 1948, 12), may be summarised as follows. Light incident on the crystal is absorbed both in the absorption band of the pure halide and also in the long wave-length tail, found in most specimens of silver halide, due to impurities and loosely bound ions at the surfaces of the crystal and at internal cracks and discontinuities in the lattice. The effect of each quantum absorbed is to transfer an electron from a bromine ion of the lattice into the conduction band, where it can move through the crystal at ordinary temperatures with a velocity of the order of  $10^7$  cm. per sec. On the macro scale this effect is appreciated as photo-conductivity. A propor-

tion of the mobile electrons is trapped by the electrons falling into lower energy levels provided by impurity specks, a role which can be taken by specks of colloidal silver or silver sulphide. Suitable specks of the latter substance are present: they are the sensitivity specks of the preceding history. The speck thereupon becomes charged and attracts silver ions to it. These move through the crystal by virtue of its electrolytic conductivity, which is due to (a) the movement of interstitial silver ions, which in silver bromide at room temperature can be shown to have a concentration of  $10^{-6}$  times that of the lattice ions; and (b) to the movement of holes, left in the structure by the movement of an ion into an interstitial position. The mechanism of (b) is a replacement, ions in neighbouring normal positions jumping into the hole, their places being filled in turn. The activation energy for this process is of the same order as that required for the movement of interstitial ions. (27=8,200 g.-cal. per g.-mol. for silver bromide.) This is dependent on temperature but not on illumination. The neutralisation of the charge allows further photo-electrons to fall into the trap, and the speck grows as long as the illumination continues. By this means



the concentration speck theory is provided with a mechanism.

The properties of silver halide which in combination make it the basis of the photographic process are therefore the long wave-length absorption "tail," which allows effective light to penetrate into the depths of an emulsion; the photo-conductivity, which is an expression of the internal photo-electric effect, the basis of the whole process, and which also allows the action of light, absorbed over the whole crystal, to be concentrated in one part of it; and the electrolytic conductivity, which allows permanent effects to result from the photo-electric currents.

The above theory will obviously fail at the outset if the bromine atom which remains after the removal of an electron by light into the conduction band is able to recombine with that electron either before or after it reaches the localised trap. A portion of the photo-electrons is undoubtedly lost by this process, but not all, since any bromine atom, in the course of its migration through the crystal by a process of successive electron jumps from ion to atom, has a high probability of either reaching the surface of the crystal and combining with the gelatin, or, if it remains stationary at any time for a period of the order of  $10^{-8}$  second, of polarising the surrounding lattice whereby it becomes trapped. The first probability is very high in any actual photographic emulsion. Most of the absorption of light is believed to take place at the surface of the grains (the interior being a nearly perfect lattice), so that the bromine is released very close to the gelatin which can absorb it.

Since the publication of the paper by Gurney and Mott in 1938, experimental testing of the theory has taken two main directions, viz., separation of the effects of electronic and ionic conductivity by experiments at low temperatures, and investigation of the topography of the distribution of latent image in the exposed silver halide grain. The low temperature experiments have involved a study of reciprocity failure, which is in effect a study of the relative efficiency of the utilisation of light energy at various intensities. A material which shows no reciprocity failure gives the same density for the same exposure, whatever the manner in which the factors intensity and time making up that exposure may reciprocally vary. At ordinary temperatures nearly all actual materials show reciprocity failure at both high and low intensities. Both at high and low intensity the material requires more energy to produce a given density than at some intermediate optimum intensity. Described in terms of the two-stage picture of latent image formation given by Gurney and Mott, high intensity failure is ascribed to the limited electric capacity of the sensitivity specks. The cloud of electrons released within the grain by the high intensity light cannot all be accommodated on the sensitivity specks at once, since the progressive neutralisation which enables a similar number of electrons to be accommodated at lower intensities no longer occurs fast enough due to the comparative slowness of the ionic movement.

Only a portion of the electrons released, therefore, can be utilised, and only a portion of the light energy is effective. The experimental evidence suggests that the remaining photo-electrons are trapped in shallow traps in the interior of the grain, where specks of internal latent image are formed normally inaccessible to the developer. Other specks too small to initiate development, but which are nevertheless stable, are formed both in the interior and on the surface of the grains. These *sub-image* specks can be brought up to latent image size, and high intensity reciprocity failure eliminated, by a subsequent exposure to very weak light. The electrons released by this additional light are trapped in the sub-image specks and cause them to grow by the ionic addition of silver in the normal manner.

At low temperatures the mechanism of the above high intensity exposures would be expected to be operative at all intensities, because of the failure of ions to neutralise traps charged up by the photo-electrons. Reciprocity failure is in fact found to disappear, because the distribution of the photo-electrons between internal and external traps and indeed the whole mechanism of latent image formation, is similar for all intensities experimentally available. If the exposed material is kept at the low temperature, which means that no ionic processes have succeeded on the electronic, the electrons can be lifted from the shallow traps by red light and will then recombine with bromine atoms, and it is found that on warming up no latent image is formed. On the other hand, if the material is warmed up without additional exposure to red light, the electrons are lifted out of the traps by the thermal energy, but since at the same time the ionic mobility increases also (varying with temperature as  $e^{-E/kT}$ ), the released electrons are able to fall into deeper traps, which by this time have lost their charge by the moving up of silver ions. The latent image thus formed in the deep traps cannot be bleached by red light at low temperatures. The immobilisation of the ionic processes at low temperatures is thus found to have the consequences required by the theory, namely, to prevent the action of light from having any permanent result. Permanent results come about only because of the fixation of the primary electronic action of light by the subsequent ionic process.

Low intensity reciprocity failure is ascribed to the instability of the sub-image specks first formed. The electrons of a small speck are but loosely held, and may escape again, whereupon the silver ions left on the speck will move back again into the lattice into interstitial positions. Such recombined electrons, and the quanta of light which produced them, are therefore lost to the photographic process. A slightly greater rate of production of photo-electrons enables the sub-image speck to attain a stable size (calculated to be about half the size of a latent image speck capable of initiating development, Webb and Evans, *Phot. J.* 1940, 80, 188), and all light absorbed by the crystal thereafter is utilised efficiently in the building of a normal latent image\*. At higher intensities the growing specks quickly and efficiently attain the stable

size, accounting for the greater efficiency of light at the optimum.

The practical importance of these facts can be demonstrated in various applications of photography. Thus the inefficiency of the very low intensity exposures common in astronomical photography can be largely removed by a pre-exposure to high intensity light of such duration that only just stable sub-image specks are formed on the majority of grains. These grains yield no density on development, but nevertheless enable, the subsequent dim light from the exposure proper to be efficiently utilised. As a curious result of this phenomenon, star images allowed to trail on the plate show a comet-shaped track. A light exposure (from the sky background) succeeds the exposure from the star image, and is efficiently utilised, at the other it precludes it and produces no permanent latent image. If the density at the start of the trail is therefore higher than at the end (Alter, Barber, and Edwards, *Monthly Notices Roy. Astronom. Soc.* 1940, 100, 529). Similarly, the efficiency of very short exposures at high intensity is increased by a post-exposure to dim light. The high intensity exposure produces large quantities of latent-image silver throughout the grains, which is not normally capable of initiating development. These specks are brought up by the post-exposure to latent-image size. In both these techniques of either pre- or post-exposure the intensifying exposure must be made immediately before or immediately after the exposure proper, to avoid sub-image fading.

These phenomena resulting from the two-stage nature of latent-image formation have been invoked successfully to explain a number of curious photographic effects, long known but inadequately understood, viz., the Clayden effect, whereby a very high-intensity exposure desensitises the grains for a subsequent moderate-intensity exposure (giving "black lightning" in photographs of thunderstorms). "This is due to internal sub-image and latent-image specks formed by the high intensity light acting as competitive traps for the electrons released by the subsequent moderate exposure. This internal image is not normally accessible to an ordinary developer, so that the surface traps, which alone can initiate development, do not receive so many electrons as normally from an equal exposure. The Albert reversal, whereby grains given a heavy exposure and then treated with oxidising agents are found to be desensitised for a subsequent additional exposure, is a similar phenomenon. The oxidising agent destroys the surface latent-image, but does not touch the internal latent-image, which then acts as a competitor for the photo-electrons of the second exposure as in the Clayden effect above (G. W. W. Stevens, *Phot. J.* 1939, 79, 27). The Villard effect, in which exposure to X-rays desensitises the grains for subsequent exposure to light, is similarly explained as a special case of the Clayden effect.

The mechanisms proposed above for the Clayden, Albert, and Villard effects would be merely speculative were it not for the development of techniques for distinguishing between

surface and internal latent-image. Basing their work on ideas first applied by Kempf (*Z. wiss. Phot.* 1937, 36, 235), Berg, Marriage, and Stevens (*J. Opt. Soc. Amer.* 1941, 31, 385) devised methods for developing only grains which carried a surface latent-image (by the use of a developer containing no silver halide solvent), and for developing only grains which carried an internal latent-image (by the use of a bleach which dissolved only the external latent-image, followed by a solvent-containing developer which gradually etched the surface of the grains, and developed the remainder when a speck of internal latent-image was reached). Previous confusion in the study of these odd photographic effects has been largely cleared up by the use of these methods. Most commercial developers contain silver halide solvents and thus develop grains with either external or internal images or both, if given time. When the images are distinguished in this way, the density due to the internal latent-image is found to increase continuously as the intensity factor  $I$  in the constant exposure  $It$  increases, while the reverse is true for the surface latent-image. This is simply to say that high intensities favour the production of internal latent-image, a result to be expected on the theory outlined above.

In conclusion, it needs to be stated that many points of the above qualitative theory require to be put on a firm quantitative basis, while a number of riddles remain for which the explanation is obscure. The fate of the bromine, the exact significance of digestion, the mechanism of dye sensitisation, as yet are only partly understood.

### III. DEVELOPMENT OF THE LATENT IMAGE.

Daguerre made the epochal discovery (in 1835, although announcement was not made until 1839) that a still invisible image formed by the action of light upon silver iodide could be transformed into a visible image by fuming the exposed material with mercury vapour. Somewhat later (1840), the Rev. J. B. Beade and, independently, Fox Talbot, showed that the latent image produced by exposure of paper impregnated with silver chloride could be developed by brushing the paper with a mixture of gallic acid and silver nitrate. Russell (*Brit. J. Phot.* 1862, 9, 425) published the first account of development by an alkaline pyrogallol solution—the forerunner of the modern alkaline developer—and Berkeley (*ibid.* 1882, 29, 48) suggested the important addition\* of sodium sulphite. The majority of the developing agents used to-day were already known by the end of the nineteenth century, primarily through the work of Andresen, the brothers Lumiere, Abney, Eder, Toth, Hauff and Bogisch (cf. Stenger, "History of Photography," Mack Printing Co., Eastern, Pa., 1939).

Modern photographic development is essentially an amplification of the latent-image material, brought about by a selective reduction of silver salt. The amplification generally amounts to several powers of ten. Two types of developing processes may be distinguished.

In the first type, the reduced silver is derived from the silver halide of the emulsion, and the process is termed (rather ambiguously) "chemical development." In the second, the reduced silver is derived either wholly or in part from a soluble silver salt contained in the developing solution. This process is termed (incorrectly) "physical development." In the subsequent discussion the term "development," used alone, refers to the more common and important "chemical development."

Development is essentially a kinetic phenomenon. Although the conventional developer can reduce all the silver salt in the unexposed areas of an emulsion if given sufficient time, reduction takes place *more rapidly in the exposed areas*. With a properly exposed emulsion of commercial quality, a good image can be developed in a time which is too short to allow reduction of more than a small amount of the silver halide in the unexposed areas. The developed silver in the exposed regions may show morphological differences from that formed in the unexposed regions, but the time factor is still the primary one in development.

The conventional alkaline developer contains (a) the developing agent proper, (b) sodium sulphite or its equivalent, (c) an alkali (such as sodium hydroxide, carbonate, borate, or metaborate) to adjust and buffer the hydrogen ion activity, and (d) often potassium bromide to restrain fog formation (reduction of unexposed silver halide). Other additions may be made for special purposes.

Several empirical correlations between the structure of a reducing agent and its ability to act as a developing agent have been suggested. None includes all developing agents, but Kendall's (IX Congr. Intern. Phot., Paris, 1935, 227) is widely applicable. Kendall associates developer activity with the structural group,  $\llbracket C=C \rrbracket_n$ , where (C=C) is the vinylene grouping,  $n$  is zero or an integer, and  $a$  and  $b$  may be hydroxyl, amino-, or substituted amino-groups. The following examples illustrate the classification:

$n=0$ : Hydroxylamine, hydrogen peroxide, hydrazine.

$n=1$ : Catechol, pyrogallol, ascorbic acid, o-aminophenol, 1-amino-2-hydroxynaphthalene-6-sulphonic acid (\**Eikonogen*\*).

$n=2$ : Hydroquinone, chlorhydroquinone, p-aminophenol, monomethyl-p-aminophenol (the sulphate of which is known as "*Mdol*" "*Elon*," etc.),  $\alpha$ -hydroxyphenylglycine (glycin), 2:4-diaminophenol (the hydrochloride is "*Amidol*"), p-phenylenediamine.

$n=3$ : Hydrocarbazone.

When the agents are aromatic compounds,  $a$  and  $b$  lie in *ortho*- or *para*-positions to each other. Various substituents may be introduced into the nuclei without destruction (although usually with some modification) of the developing properties. Among these substituents are: additional hydroxyl and amino-groups, alkyl and alkoxy-groups, halogen atoms, and the sulphonic acid group.

Exceptions to the Kendall classification include sodium hydrosulphite, trioxymethylene,

and a group of agents characterised by a valence change of a metal during oxidation (c/. Rzymkowski, Phot. Ind. 1941, 39, 4971. Various ferro- and niolybdo-complex ions, such as the oxides and niolybates, are representative of the group, which includes the historically important "ferrous oxalate,"  $Fe(C_2O_4)_2$ . Even a simple ferrous sulphate solution acts as a developer when a suspension of zinc dust or iron powder is maintained to reduce the ferric ion as it forms (Ammann-Brass, *ibid.* 1937, 35, 827).

During development by the aromatic agents, oxidation products (quinones or quinone-imines) are formed which, if not quickly removed, often undergo subsequent reactions leading to the formation of highly coloured substances. Similar substances are formed in the aerial (oxygen) oxidation of the developing agents. Such coloured substances can seriously stain the photographic material. Sulphite in the developer serves the dual purpose of preventing the formation of the staining material and of generally retarding the aerial oxidation of the developing agent. Both effects apparently are associated with the ability of the sulphite to react with a quinone or quinone-imine in alkaline solution, forming a soluble and often colourless sulphonate. Thus, when hydroquinone reacts with silver bromide in the presence of sufficient sulphite, hydroquinone monosulphonate is formed in a reaction which can be represented stoichiometrically (Lehmann and Taiwcb, Phot. Korr. 1935, 71, 17) as follows:

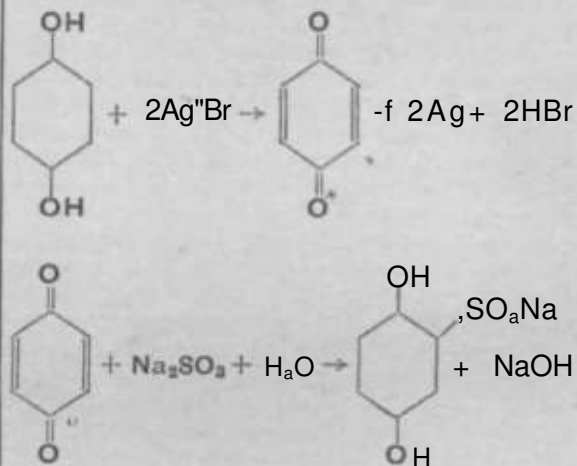

Reactions of many of the other aromatic developing agents follow a similar course when sulphite is present (Seyewetz and Szymson, Bull. Soc. chim. 1033, [iv], 53, 1260; 1034, [v], 1, 1506). When the developing agent reacts with oxygen, the quinone or quinone-imine formed can act as a catalyst, and the inhibitor action of sulphite upon oxygen oxidation is due (at least in part) to the removal of the catalyst (James and Weissberger, J. Amer. Chem. Soc. 1939, 61, 442).

**Mechanism of Development.**—The silver halide grain acts as a unit in development, and the mechanism of development must be considered in terms of the individual grain. The presence of one or more suitable latent-image centres in a given-grain increases the initial rate at which the developing agent attacks the grain.

Reduction of such a grain starts at one or more discrete spots (corresponding, presumably, to the latent-image centres) on the grain surface, and thence proceeds throughout the grain as an auto-accelerated process. The silver formed acts as the accelerator. How large a nucleus must be before its presence on the grain surface materially effects the start of reduction, and whether the silver atoms in that nucleus must be in some particular configuration, are questions still open to speculation. However, there is evidence that in the region of low exposure, the removal of one silver atom from an average latent-image centre will quite measurably decrease its effectiveness (Kornfeld and James, *J. Opt. Soc. Amer.* 1943, 33, 615).

Most investigators are in agreement that, in the absence of appreciable silver halide solvent action, the major portion of the development reaction takes place at or very near the interface between the silver and the neighbouring silver halide. However, there are diverse opinions as to why the reduction occurs more readily at the interface than at any other portion of the grain surface. One assumption is that a transfer of electrons from developing agent to silver metal takes place, more easily than to silver halide, and the silver acts primarily as an electrode. Bagdasar'yan (*J. Phys. Chem. Russ.* 1943, 17, 336) assumes that the rate of reduction of silver ions at the interface is controlled by the rate of transfer of electrons from the developing agent to the silver nucleus. His quantitative formulation, however, is in only partial agreement with the experimental results. Gurney and Mott assume that only interstitial silver ions are reduced at the supposed electrode, but serious objections to this view have been raised (*c.f.* S. E. Sheppard, "Colloid Chemistry," edited by J. Alexander, Reinhold Publ. Co., New York, 1944, Vol. V, p. 472; James and Kornfeld, *Chem. Rev.* 1942, 30, 1).

Several investigators have treated development as a matter of heterogeneous catalysis (Sheppard and Meyer, *J. Amer. Chem. Soc.* 1920, 42, 689; Volmer, *Z. wiss. Phot.* 1921, 20, 189; Rabinovich, *ibid.* 1934, 33, 94; James and Kornfeld, *l.c.*). Sheppard and Meyer suggested that the silver facilitates the decomposition of an adsorption complex formed between developing agent and silver ions. Rabinovich believed that adsorption of the developing agent to silver is of primary importance, but his supporting experimental evidence is unconvincing because of the large experimental error involved (Sheppard, *op. cit.*). Kinetic studies of the reduction of silver ions from solution in the presence of colloidal silver do indicate adsorption of hydroxylamine and *p*D-phenylenediamine, but do not indicate adsorption of hydroquinone.

The rate of reduction of silver ions from solution by hydroquinone and hydroxylamine varies with a fractional power of the silver-ion concentration when colloidal silver is present as catalyst (James and Kornfeld, *l.c.*), and James suggested that adsorption of the silver ions to the silver permits the reaction to proceed with less energy of activation. Results obtained in a study of the reduction of silver halides, both gelatin-free and in the presence of gelatin, sup-

port this view. Satisfactory measurements of the activation energies involved have not been made, but the temperature coefficients which have been determined are considerably smaller for the catalysed than for the uncatalysed reactions, and the oxidation product is even different for the two reactions in the case of hydroxylamine (James, *J. Amer. Chem. Soc.* 1942, 64, 731). Agents which apparently reduce silver ions directly with little or no energy of activation (*e.g.*, sodium stannite, desylamine) are not developers.

The precise course of development may be modified by the presence of a silver halide solvent in the developer. (Even sodium sulphite exerts sufficient solvent action to be of importance in many cases.) If some of the silver halide passes into solution before it is reduced, silver ions from the solution may subsequently contribute to development by being reduced at the silver nuclei of the developing grains. If conditions are such that this process takes place to any very large extent, the form of the silver deposit and the rate of development may be changed (*cf.* section on "fine grain" development, p. 5636).

The electrical environment surrounding the silver halide grains is of some importance in determining the course of development. Excess halide ions are adsorbed to the halide grains, producing an excess negative charge on the surface. Many of the developing agents are active only in the form of negative ions, and the charge at the grain surface acts as a barrier to the approach of the developer ions. The barrier is probably weakened in the vicinity of the latent-image nuclei (de Langhe, *Z. wiss. Phot.* 1936, 35, 201), so that the ions approach the surface more readily at those spots. This charge effect cannot be the primary reason for the differential action of developers, however, since many good developing agents are known to act in the form of neutral molecules. The most important effect of charge barriers (from both bromide ions and gelatin) is upon the kinetics of development by ionic agents.

The appearance of the developed silver may vary considerably with the conditions of development and with the nature of the original grain. However, electron micrograms of partly and completely developed grains show that the silver obtained in normal development has an irregular and filamentary fine structure (Ardenne, *Z. angew. Phot.* 1940, 2, 14; Hall and Schoen, *J. Opt. Soc. Amer.* 1941, 31, 281). Extremely small grains, such as those of the Lippmann emulsion, often are converted into single, thin filaments which in length may exceed by several times the diameter of the original grain. The filaments formed in development appear to be silver crystals which have grown chiefly in one dimension (Jelley, *J. Phot. Soc. Amer.* 1942, 8, 283). Migration of the newly reduced silver atoms along the silver surface is probably involved in the formation of such crystals (James, *J. Chem. Physics*, 1943, 11, 338; Berg, *Trans. Faraday Soc.* 1943, 39, 115).

Kinetics of Development.—Meidinger, in an investigation of the development of (atypical) individual silver bromide grains in a metol-hydro-

quinone solution (Physikal. Z. 1935, 36, 312), found that: the rate of initiation of development,  $hi$ , increased with increasing light exposure in the normal exposure region and decreased in the solarisation region; the rate of continuation of development throughout the grain,  $k_c$ , was independent of exposure; both rates decreased with increasing bromide ion concentration, but the decrease in  $hi$  was relatively much greater than in  $k_c$  at low bromide concentrations; both rates increased with increasing pH and developer concentration. Babinovich, Bogoyavlenski, and Zuev (Acta Physicochim, U.B.S.S. 1942, 16, 307) found that the radius of the visible darkening area varied exponentially with time of development in a hydroquinone solution, *i.e.*,

Under certain limited conditions, the kinetics of development of a single grain are substantially those of development of the entire group, *i.e.*, of gross development of the emulsion. This is true for a simple, heavily exposed motion-picture positive film developed in a sulphite-free hydroquinone solution of pH 8-9 (James, J. Physical Chem. 1940, 44, 42). The development rate varies approximately as the square root of the concentration of the bivalent ion (the actual developing agent), suggesting adsorption of that ion prior to reaction. The evidence is against adsorption to silver, so the adsorbent probably is the silver halide or the interface.

In the more general case, the rate of development measured by the growth of density or gamma (defined in Section V, p. 568a) is often a complex quantity. The change in density as development progresses may result primarily from a change in the *size* of the particles of developed silver, from a change in the *number* of developed grains, or from a mixture of both. Usually, it is impossible from the published data to interpret, the gross rate of development quantitatively in terms of the individual grains. This is true for most of the results reported in subsequent paragraphs, where only gross rates are available.

The kinetics of gross development may vary with the nature and amount of exposure, and with the nature of the photographic material itself. In rapid development, where diffusion rates are of importance, the rate of development increases with increasing agitation (Ives and Jensen, J. Soc. Phot. Pict. Eng. 1943, 40, 107), and the tendency towards unevenness, such as streaking, decreases. Wetting agents are sometimes of use in promoting more uniform development. Increase in the concentration of the developing agent produces an increase in the rate of development, provided pH is kept constant. Increase in pH usually produces, an increase in rate (the ferric-oxalate type of developer is an obvious exception). Some developers are much more sensitive to changes in pH than others, and the agents vary considerably as to the pH range useful under practical conditions (Beinders and Beukers, Ber. VIII Int. Kongr. Phot., Dresden, 1931, 111; Burki and Ostwalt, Helv. Chim. Acta, 1939, 22, 30). Among the agents containing hydroxyl groups, the effect of pH is associated primarily

with the ionisation of those groups. The ions are the active developing agents, and a change in pH changes the effective concentration. The dependence of rate upon pH for solutions containing p-phenylenediamine derivatives is less clearly understood. It has been demonstrated, however, that the oxidation products of these agents retard development, and possibly an increase in pH accelerates development simply by increasing the rate of removal of the oxidation products (James, J. Physical Chem. 1939, 43, 701).

Bromide decreases the rate of development, and the effect, especially among the charged agents, is more pronounced at low exposures than, at high. Small amounts of bromide (0.05 M. or less) usually decrease the rate of fog formation to a greater extent than the rate of image development, and bromide is used as a "fog-restrainer" for this reason. High concentrations of bromide, particularly when used in high-activity developers, may actually increase fog formation, however, presumably because of the solvent action upon the silver bromide. Certain organic substances, such as 6-nitrobenzimidazole and benzotriazole, are also useful as fog restrainers under certain conditions (Trivelli and Jensen, J. Franklin Inst. 1930, 210, 287; 1931, 212, 155).

The effect of the bromide charge-barrier upon the kinetics of development is pronounced in the early stages of the process. The existence of an *induction period* has been explained on the basis of a localised decrease in the relative magnitude of the bromide barrier as development proceeds (James, *l.e.*). The decrease in the barrier results in an increase in the percentage of developer ions which possess sufficient kinetic energy to penetrate the barrier and reach the reaction site. The duration of the induction period is increased relative to that of the later stages of development by an increase either in the charge of the developing agent or in the initial magnitude of the bromide barrier.

The rate of development increases with the temperature of the solution, but excessive softening of the gelatin imposes an upper limit on the temperatures which can be used in practical development. The temperature coefficient depends upon the nature of the developing agent, the composition of the solution, and often the nature of the emulsion. The coefficient for commercial developers often decreases with increasing pH (Burki and Jenny, Helv. Chim. Acta, 1943, 26, 2264) and increases with increasing bromide ion concentration.

Frequently, two developing agents may be used to advantage in the same solution. The commonly employed metol-hydroquinone developer combines desirable features of each component. The metol starts the development of the individual grains, and the hydroquinone plays a more prominent part in the later stages. The flexibility of the combination is so great that it has been used in developers designed for practically every requirement within the scope of black and white photography. The rate of development by the combination is generally greater than would be predicted from a simple addition of the individual rates. This non-

additive property is associated with the charge effect (James, J. Phot. Soc. Amer. 1943, 9, 62).

With repeated use, a developer gradually loses its activity. The concentration of developing agent decreases, the pH generally decreases, and halide ion accumulates. Aeration of a hydroquinone developer will tend to increase the pH (Crabtree and Schwingel, J. Soc. Mot. Pict. Eng. 1940, 34, 375), but in practice this seldom suffices to offset the decrease which accompanies reaction with silver halide. If the activity of the developer is to be maintained at a constant level, a replenisher must be added as needed. The composition of the replenisher and the rate of addition to the developer depend upon the developer itself and the conditions under which it is being used (*c.f.* Evans, *ibid.* 1938, 31, 273).

**Physical Development.**—Physical development in its simplest form follows the fixation process. The silver halide is first dissolved (fixed) out in alkaline thiosulphate solution or in some other solvent which will not seriously attack the latent image during fixation. The image is then developed in a solution consisting of a reducing agent, a soluble silver salt, and certain substances which act to maintain the proper silver and hydrogen-ion activities. Within certain limits, the mass of developed silver is proportional to the number of suitable latent image centres (Arens and Eggert, Z. Elektrochem. 1929, 35, 728; Arens, Z. wiss. Phot. 1932, 31, 68). The mechanism is probably that of a catalysed reduction of silver ions at the silver nuclei. The term "physical" development is definitely a misnomer.

In a modified form (pre-fixation physical development) the silver halide is not dissolved out first, but the developing solution contains a strong silver-halide solvent which dissolves the halide as development proceeds (*c.f.* Odell, Brit. J. Phot. 1933, 80, 286, 303). Both the silver halide and the silver salt originally present in the developer contribute to the final image.

**Fine-grain Development.**—"Graininess" refers to the observer's visual impression of non-uniformity of the photographic deposit. *p*-Phenylenediamine is the outstanding developing agent which yields low graininess (i.e., fine-grain). The strong solvent action of the diamine is undoubtedly of importance in this effect. Many points of similarity with physical development (which generally gives low graininess) are observed, and electron micrograms of the silver formed in the two cases show a similarity in structure of the developed grain, with no evidence of filament formation in either.

In the case of other developing agents, fine-grain is largely a function of the composition of the developing solution. Solutions having low or moderate rates of development often give reduced graininess when certain silver halide solvents are present (although the results obtained may vary markedly with the emulsion employed). Useful solvents include sodium sulphite (in large amounts), certain organic amines (*e.g.*, *p*-phenylenediamine), and potassium or ammonium thiocyanate. In all cases where a decrease is produced, however, it is achieved only at a sacrifice in effective emulsion speed.

**Reversal.**—Reversal development is a method of obtaining a positive image on the same film as that used for the original exposure. The first step consists in developing the negative image fully. The film is then washed briefly and transferred without fixing to an acidic potassium permanganate or dichromate bath where the developed silver is dissolved out. A clearing bath, usually containing sodium bisulphite, is used to remove the bleaching agent and reaction products, and the remaining silver halide is then exposed and developed to give the positive. As a means of rectifying faulty camera-exposures, the amount of exposure prior to the second development is usually controlled. Thus, if the film were underexposed in the camera, too much silver halide remains after the first development. Compensation is effected by using a small secondary exposure, so that only a portion of the silver halide remaining will be reduced during the second development. An alternative method of compensation depends upon varying the time of immersion in a primary developer which contains a small quantity of thiosulphate or other strong silver-halide solvent. If the camera exposure were too small, a portion of the undeveloped silver halide can be dissolved out by a long immersion in the primary developer, thus decreasing the amount available for secondary development. In some cases of reversal development, it is desirable to eliminate the necessity of a secondary exposure, and this can be accomplished by using a highly-fogging developer or a non-selective reducer for the second development.

Reversal development is often used in processing amateur sub-standard motion-picture film. Only one film is required instead of the two demanded by the normal negative-positive process. In addition, somewhat lower graininess may be obtained because the larger, more sensitive grains are eliminated during the primary development and bleaching.

#### IV. THE FIXATION AND PERMANENCE OF PHOTOGRAPHS.

The primary action of the fixing bath is to remove the silver halide unchanged by the developer. It thus "fixes" the image and the record is stable on further exposure of the material to light. While a number of agents have been used for this purpose in the history of the art, modern commercial practice relies almost exclusively on solutions of sodium thiosulphate. This reagent is cheap, non-poisonous, and readily made up into fixing baths. The action is due to the formation of soluble complex ions with the silver ions of the silver halide. The complex ion has a very low dissociation factor, and consequently the silver ions which result from the slight solubility of the silver halide are removed from the field as fast as they are formed. The silver halide therefore goes on dissolving since the product of the silver and halogen ion concentrations never reaches its solubility product.

The nature of the salts of argentothiosulphuric acid formed in a fixing bath has been the subject of a number of investigations. Bassett and

Lemon (J.C.S. 1933, 1423) showed that only the following salts exist in contact with solutions of suitable composition:

(a)  $\text{Na}_3\text{Ag}(\text{S}_2\text{O}_3)_2 \cdot 2\text{H}_2\text{O}$ , readily soluble in water; (b)  $\text{Na}_5\text{Ag}_8(\text{S}_2\text{O}_8)_4 \cdot 2\text{H}_2\text{O}$ , readily soluble; (c)  $\text{NaAgS}_2\text{O}_3 \cdot \text{H}_2\text{O}$ , sparingly soluble; and (d)  $\text{NaAg}_3(\text{S}_2\text{O}_3)_2 \cdot \text{H}_2\text{O}$ , very slightly soluble. There is evidence that in solution the above compounds yield only the negative ions  $\text{Ag}(\text{S}_2\text{O}_3)_2^-$ , and  $\text{Ag}(\text{S}_2\text{O}_3)_3^{2-}$ .

In addition to dissolving the unchanged silver halide, the fixing bath must allow the silver complexes to be washed out of the material without decomposition on dilution, must not appreciably attack the image of finely divided silver, and must tolerate without adverse effects the addition of developer absorbed in and on the photographic material placed in it. It is further desirable that development should be instantly arrested on placing the material in the bath. This avoids patches of extra development at places where the access of the fixing bath is partly obstructed by local contacts with the walls of the vessel or the surfaces of other photographs, and prevents stains due to the continued reduction of silver after it has gone into solution in the bath, or to oxidised developer itself. Practical considerations as to the speed of fixation, the life of the bath, and its stability on storage with or without use must also be met. The incorporation of an agent which hardens the emulsion is also often of the greatest practical utility.

The various acid and acid-hardening fixing baths now in general use have resulted from attempts to meet these requirements. No special means are needed to avoid decomposition of the silver complexes on washing; it is a fortunate circumstance that the silver-thiosulphate complexes are removable by water without any precipitation. Some attack on the finely divided silver does occur, but is of no practical importance in ordinary photography except in strongly acid baths, containing from 6-10% of sodium thiosulphate, in the presence of air. To stop continued action of the developer the bath is made acid. As the thiosulphate is unstable in the presence of acids, depositing sulphur, the bath can only be given an acid reaction by the simultaneous addition of a weak acid, such as acetic, and a sulphite. According to the work of Bassett and J. V. T. & N. U. (*ibid.* 1927, 1401), thiosulphuric acid, in the range of acidity encountered in fixing baths, decomposes in two ways, according to the equations;



and



Both these reactions tend to go from left to right in acid solutions, but (1) proceeds much faster than (2). The trithionate product of (2), however, can react with the sulphur to form tetrathionate and pentathionate. The added sulphite acts by shifting the equilibrium of the reaction (1) from right to left, thus allowing the products of the slower reaction (2) to react with the sulphur formed, thus keeping its concentration below the precipitation limit, for the necessary length of time.

It is evident, however, that the above balance will only be maintained within a certain pH range. If the bath is made too acid, the practicable addition of sulphite will prevent its early sulphurisation. On the other hand, the bath must be acid enough to stop development. The limits thus set to the pH range may be further narrowed by the requirements of some other ingredient, such as alum, added for hardening purposes. For economic reasons this narrow pH range must be nevertheless accompanied by a large reserve of total acidity, or the bath will be neutralised by the developer carried over on the photographic material long before its fixing powers are exhausted.

These conditions are met by ensuring that the solution has a very considerable buffer action. In practice the lower limit of pH is set by the tendency of the bath to precipitate sulphur and this is kept under control by the use of a weak acid, such as acetic, while the upper limit is determined by the disappearance of the hardening properties of the added alum or the onset of "sludge," a gelatinous precipitate of hydrated aluminium sulphite. To avoid these adverse effects of neutralisation by developer it was at one time the practice, in large commercial establishments, to revive the fixing bath periodically by the addition of further acetic acid, so as to maintain its pH always below 4.8. In a bath with an addition of boric acid, however, the pH may rise to 6.5 before hardening becomes insufficient and to 8.0 before sludging sets in (H. D. Russell and J. I. Crabtree, *J. Soc. Mot. Pict. Eng.* 1933, 21, 137). The improvement is due to the formation of a complex coordination compound between the boric acid, the acetic acid, and the aluminium. Such baths can be worked until discarded for failure to fix (without revival with acid). Baths with chrome alum as hardening agent require to be revived periodically with sulphuric acid and lose their hardening properties on storage with or without use.

The speed of fixation is found to increase up to a sodium thiosulphate ("hypo") concentration of 30-40%. It varies markedly with the grain size and iodide content of the emulsion, being greater if these are small, and is much increased by agitation and by rise of temperature. As the bath is exhausted the rate of fixing falls off due to consumption of hypo, dilution with water carried in with the material, and accumulation of dissolved silver. In practice the bath is usually discarded as too slow before the silver has accumulated to such a degree as to endanger the whites of the image (on negative materials) by subsequent breakdown of retained silver complexes. The use of ammonium thiosulphate, or the addition of ammonium salts to the bath, gives quicker fixation.

In a fresh bath fixation is complete (in the sense that all the unreduced silver can be removed from the material by water alone), when the visible turbidity due to undissolved silver halide has disappeared. With partially exhausted baths there is an apparent mordanting of complex silver-bearing ions by the gelatin requiring much longer immersion or preferably a second fresh bath to ensure their complete



removal by water. In the case of paper prints particularly, this mordanting to the gelatin, baryta coat and paper fibres may lead to stained white after keeping and the practice of passing prints to a second fresh bath aids materially in ensuring the complete removal of silver salts in the wash water.

#### WASHING.

In order to ensure permanence of untuned silver images, washing must be complete. In its absence, the silver image is slowly transformed into an unpleasant yellow-brown image of silver sulphide, while the high-lights become stained by the breakdown of the argentothiosulphates to silver sulphide. Ideal washing, in which the flow of water over the face of an emulsion is sufficient to remove the thiosulphate ions as fast as they escape from the gelatin, will reduce the thiosulphate concentration of materials on impermeable supports to a sufficiently low level in some 6 minutes. Practical washing apparatus, in which the hypo cannot be considered to be diffusing from the gelatin into clean water, requires, longer times depending on the design of the apparatus. Provided that the design is such that the volume of the wash water is the least necessary to cover the materials, and that it is changed frequently by complete draining and refilling, or by vigorous continuous flow, washing of materials on impermeable supports at temperatures of 16-21° C. is complete in some 30 minutes. Elimination of hypo is favoured by increased temperatures, and is somewhat more rapid from films and plates fixed in a non-hardening fixing bath, particularly at pH values below 5 (Crabtree, Eaton, and Muehler, *ibid.* 1943, 41, 9). The use of these last two expedients is limited by the danger of excessive swelling and reticulation. Sea water will remove the hypo faster than fresh, while the addition of ammonia to the wash water, or as a preliminary bath, will reduce the time of washing by 50%.

The complete washing of paper prints is both more difficult and more important. The fine-grained image is much more susceptible to fading, while the paper and the baryta coat retain small amounts of thiosulphate with great tenacity. Even washing times of 20 hours do not remove all the hypo, leaving quantities sufficient to cause fading under conditions of high humidity and temperature, as in the tropics. For the utmost permanence, therefore, the last traces of hypo must be removed by a chemical bath. Alkalis alone, by bringing the amphoteric colloids of the paper to the alkaline side of their isoelectric points, are sufficient if sufficiently applied (*e.g.*, 0.3% ammonia applied for 45 minutes). Faster treatment is attained by the simultaneous use of hydrogen peroxide, which in the alkaline environment oxidises the thiosulphate completely to sulphate (Crabtree, Eaton, and Muehler, *Phot. J.* 1940, 80, 458). Even prints so treated are liable to fade owing to the action of hydrogen sulphide in the atmosphere. This action can be greatly reduced by varnishing the surface of the print or better by superficial plating of the silver grains with gold in a gold toning bath, or both.

For the ordinary prints of commerce the

reduction of the residual hypo to 0.002 mg. per sq. in. for chloride papers, and to 0.02 mg. per sq. in. for chlorobromide papers, is sufficient to cater for their usually ephemeral interest. This can be achieved without the use of hypo eliminators. In commercial practice, it is easy to recontaminate prints after the use of hypo eliminators, leading eventually to patchy fading more obnoxious than the uniform fading it was desired to prevent.

Another solution to the problem of permanence is to tone the silver image to silver sulphide, selenide, or telluride in an appropriate toning bath. The direct method of sulphide toning most used is known as "hypo-alum" toning. It depends upon toning by colloidal sulphur produced in a warm bath of a solution of sodium thiosulphate and alum. It tends to give purple tones on bromide papers. Warmer tones are obtained by the indirect methods, in which the silver image is first bleached to a silver halide image, usually with a bath of potassium ferricyanide and potassium bromide, and after washing toned to the sulphide by immersion of the print in a dilute solution of alkali metal sulphide. Alternatively a solution containing thiourea (0.1%) and caustic soda (0.4%) tones the image to sulphide at a slower rate but the bath has the merit of being odourless. Selenium toning is usually effected in a bath of selenosulphate prepared by dissolving powdered selenium in solutions of the alkali metal sulphites, while tellurium is used in the form of a sulphotellurite made by fusing tellurium with alkali metal sulphides. The dark brown images produced by proper handling of these toning processes are popular in their own right and have the added advantage of being extremely permanent, so much so, indeed, that sulphide toning is often the simplest way of conferring permanence on prints.

Methods of producing coloured images by precipitation of coloured metallic salts in the gelatin by the agency of the silver image are legion. A solution will tone if it oxidises the silver image by means of an ingredient which when reduced reacts *in situ* with a metal ion also present to yield a coloured insoluble salt. The most usual oxidising agent is potassium ferricyanide, which when reduced to ferrocyanide precipitates a coloured metallic ferrocyanide image, *e.g.*, red and brown from copper, blue from iron, brown and red from uranium. The higher compounds of vanadium and molybdenum can function both as oxidiser and as source of metal ion; they are reduced by the silver to the lower insoluble coloured form. Coloured images made by transforming the silver image to a form in which it can mordant dyes have also been extensively used, chiefly for pictures on transparent waterproof supports (motion and still pictures for projection). Weak images of silver iodide; silver, copper, and uranium ferrocyanides; silver sulphide; lead, tin, cobalt, and chromium salts, have all been used to mordant dyes. In many cases if the gelatin is treated with tannic acid the mordant can be withdrawn by a chemical bath without undue diffusion of the dye image.

Images composed of metallic ferrocyanides

suffer from ready solubility in alkaline solutions and waters and cannot be regarded as permanent. The dyes used in mordanting processes are usually basic dyes and suffer from the relative lack of fastness of such dyes to light. Only the sulphide, selenide, telluride, gold and platinum toning processes can be regarded as making a real contribution to the problem of permanence.

#### V. QUANTITATIVE RESPONSE OF PHOTOGRAPHIC MATERIAL TO LIGHT.

The quantitative response of photographic materials to light is the main study of that branch of photographic science known as sensitometry. Originally developed as a means of measuring the *sensitivity* of photographic materials in response to the acute practical need of photographers desiring to judge their exposures, the modern science is concerned not only with the relative and absolute sensitivity of photographic materials to radiant energy of various kinds, but includes the study of the effect of the development, and of after-processes such as intensification and reduction, on the whole relation between the image finally produced on the material and the intensity, duration, and quality of the radiation that produced it. Its results, combined with those of the sciences of vision, are applied directly to the study of the fidelity of tone reproduction of the photographic process as a whole, providing by their detailed analysis of the various factors in operation the means for steady improvement. As a practical tool in the large-scale manufacture and use of photographic materials, sensitometry is indispensable, while its place as a foundation study in scientific research on the photographic process and in the use of photography as a scientific instrument will have been evident from the following pages.

Precision sensitometry requires therefore a steady light-source reproducible to specification, means of making a graduated series of exposures to that light, a method of development under standard conditions, and a means of measuring the deposit produced by the previous steps. Both the nature of these means and the interpretation of the results depends on the objects of the study. Certain broad applications of sensitometry are of wide interest (*e.g.*, the determination of the speeds of negative materials) and appropriate specifications for some or all of the above essential requirements have been laid down in national (*e.g.*, the German DIN system, 1931) or international agreements. Others are the subject of scientific study with a view to ultimate international agreement. Thus the Seventh International Congress of Photography, 1928, agreed on the specification of the international unit of photographic intensity, which is defined as one visual candle-power of radiation of the quality emitted by a tungsten electric source operating at 2,360°K. screened by a liquid Davis-Gibson filter made up to a precise specification. This source and filter combination duplicates very closely the spectral quality of mean noon sunlight at the earth's surface. Sources of different spectral quality are con-

siderably used in photography (*e.g.*, the arc lamps used in photomechanical work, the fluorescent screens of medical and Industrial radiography), and the manufacturers of materials for these applications may find it necessary to test them with artificial sources of the same spectral quality, but such sources have not been made the subject of international agreement.

The modulation of the exposure to light from the agreed or standardised source is effected in a *sensitometer*, which is a precision instrument for controlling the intensity or time of exposure in a known and regular manner from one end to the other of a strip of the material under test. Descriptions of instruments have appeared in comprehensive reviews (C. E. K. Mees, "Theory of the Photographic Process," Macmillan, 1942, p. 607; Davies, *Phot.* 7. 1944, 84, 185), and are out of place here. Suffice it to say that two main divisions exist, depending on whether the design effects control by varying the time or the intensity of exposure. Given a steady light source, a time-scale sensitometer is easier to build to high precision and consequently the early sensitometers (such as that of the pioneers of scientific sensitometry, Hurter and Driffield (J.S.C.I. 1890, 9, 455)) were time-scale instruments. Most actual applications of photography, however, result in the exposure of the photographic material to a pattern of light and shadow for a constant time, so that the effects of reciprocity failure (Section II, p. 5586) make it necessary for the materials to be tested in an intensity-scale instrument, and moreover for exposure times of the same order as that used in the appropriate application, *e.g.*, 1/50th second for amateur negative materials; 1/20,000th second for sound-recording films. The design of intensity-scale sensitometers with the necessary range of some 10,000 to 1 in intensity, which is required to reveal the whole response of the photographic material to light, has proved a difficult physical problem, as the intensity modulating device must in no way modify the spectral quality of the light. Moreover, the intensities required at the upper end of the scale are very high and can only be attained by placing the light source close to the emulsion layer. The most modern instruments therefore usually employ a succession of exposures of constant time but increasing intensity step by step along the strip (Bornemann and Tuttle, *J. Opt. Soc. Amer.* 1942, 32, 224; Davies, 1944, *I.e.*).

The development of the exposed sensitometric strips may be conducted according to the practice of the trade using the materials in question (*e.g.*, motion-picture film, X-ray film) or more usually, is conducted as a laboratory operation in specially designed machines where agitation, temperature, and time can be controlled to close limits. Preliminary experiments establish the conditions which give a result equal to the average of the best trade practice. These are then adopted as standards in the sensitometric laboratory, and, in contradistinction to trade processing, can be exactly reproduced. In the scientific study of photography, of course, the manner of development depends on the purposes of the investigation. In nearly all cases a primary requirement is that development shall

be uniform at all parts of the exposed material, and one of the best ways of effecting this is to brush the surface of the exposed material continuously during development with a soft long-haired brush (Clark, Phot. J. 1025, 65, 76).

In the pioneer sensitometric work of Hurter and Driffeld, their aim was to measure the mass of silver produced by a known exposure and development on the materials available to them. By comparing the results of chemical analysis of the deposits with measurements made on a photometer, they found that to a sufficient approximation Beer's law was obeyed, i.e., that the mass of silver was proportional to the density of the deposit, which they defined as the common logarithm of the opacity. Mathematical, if  $I_0$  units of homogeneous radiation fall on one side of the deposit, and  $I$  units emerge from the other side, then

$T$  is the transparency,  $T$ ,  
 $O$  is the opacity,  $O$ ,

and the density,  $D$ , is defined by the relation

$$I = I_0 \times 10^{-D}, \text{ whence } D = \log_{10} O.$$

Moreover, by the law of indices, two layers superimposed behave to the incident beam as if their densities were additive. Thus with two layers of densities  $D_1$  and  $D_2$ , we have

$$I_1 = I_0 \times 10^{-D_1}; \quad I_2 = I_1 \times 10^{-D_2},$$

whence  $I_2 = I_0 \times 10^{-(D_1 + D_2)}$ .

This property of density makes it the most useful means of specification of photographic deposits in optical calculations.

Hurter and Driffeld's use of density as a measure of the mass of silver in photographic deposits is rarely employed in modern applications of sensitometry. Indeed, it has been shown (Sheppard and Ballard, J. Franklin Inst. 1928, 205, 659) that the relation between the density and the mass of silver varied considerably, according to the conditions of develop-

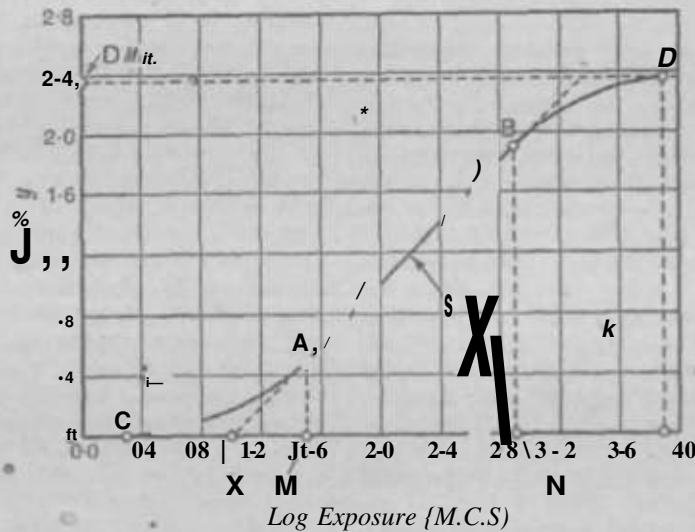

FIG. 4.—THE CHARACTERISTIC CURVE OF HiBTz AND DRIFFELD.

ment. In most applications of sensitometry, density is simply used as an optical concept, since it is the optical properties of the photographic image which give it its usefulness either as intermediate negative or final print. In dealing with prints on opaque white or light-coloured supports, the reflection density is defined by analogy with the density of transparencies, as  $R = \log_{10} (1/f)$ , where  $E$  is the reflectivity defined as the ratio between the light reflected by the image and that reflected by the support alone.

The measured density of a photographic deposit, whether on a transparent or an opaque support, depends to some extent on the conditions of measurement. For transparencies, two extreme cases present themselves, (a) when only the light transmitted normal to the sample is measured, giving the specular density  $D_s$ , and (b) when all the light transmitted by the sample, including all the scattered light, is measured, giving the diffuse density  $D_d$ .  $D_d$  is always higher than  $D_s$  for scattering deposits, so that the contrast of a print made by colli-

dated light in a projection printer is higher than that of a similar print made by diffused light in the same printer. On the other hand, a print made by contact, in which the printing frame is exposed to a diffuse source of light, may have a higher contrast again because much of the effective light has travelled through the deposits at an angle. Where the light source is small, however, the contrast falls since all the scattered light contributes to image formation. In the absence of an agreed international specification of the means of measuring density, the sound rule is to employ as far as possible the same optical arrangement as will function when the transparency is used.

The standard way of expressing the response of photographic material to light is to plot the density resulting from exposure and a given degree of development against the logarithm of the exposure. The result is the characteristic curve of Hurter and Driffeld (Fig. 4) which represents the response of the material for one particular degree of development. Over a considerable portion of its length, A to B in the

figure, the curve is a straight line. In this region the densities are directly proportional to the logarithms of the exposure, and if the material has been exposed for a constant time to varying intensities of light, the light emerging from the transparency duplicates inversely the original intensities  $I$ , the transparency  $T$  of each part obeying the equation  $I T = P$ . Hurter and Driffield therefore called this straight-line region the region of correct exposure. The gradient of the curve  $dD/d(\log E)$  is a constant in the straight-line portion and was called  $\gamma$ , where  $\gamma = \tan \alpha$ . If  $\gamma = 1$ , the negative reproduces exactly the brightness contrast of the original exposure; if less or more than 1, the contrast reproduction is compressed or expanded but remains proportionately correct. The limits of correct exposure (as above defined) are fixed by dropping perpendiculars from A and B on to the log (exposure) axis. A material so exposed that the density of the deepest shadow falls at A, will accommodate correctly all higher exposure values up to that represented by N, the ratio  $Es/Esi$  being known as the *latitude* (in exposure units). It may amount to several hundred to one, with present-day double-coated materials.

The position of the curve with relation to the log (exposure) axis indicates the *speed* of the material. Hurter and Driffield produced the straight-line portion backwards until it cut the log (exposure) axis at  $x$ , and called the exposure value at this point the *inertia*. The speed was then expressed by a figure proportional to the reciprocal of the inertia\*. With the materials and developers of their day they found that the inertia was independent of the extent of development, and was therefore regarded as a constant of the material\*.

Study of the whole problem of tone reproduction in photography with present-day materials has shown that the *toe* of the curve of negative materials invariably is, and indeed should be, utilised, if the print is to represent the original scene to the best of its capabilities. Moreover, some widely used negative materials have a long sweeping toe portion, so that if exposures were such as to put all the densities on the straight line, the negative would not only be dense, but the exposures much longer than is necessary. In other materials the inertia falls rapidly as time of development is prolonged, so that the H. and D. speed depends greatly on the degree of development. Consequently, various ways of determining the speed from properties of the characteristic curve other than the inertia have come into use. Threshold methods determine the exposure required to produce a density which is a small predetermined level above fog (e.g., the just detectable difference; 0.1 above fog, etc.), but such methods are not related logically to the requirements of tone reproduction. A consideration of the reasons for dissatisfaction with the shadow areas of photographs indicates that this is mainly due to the loss of tone discrimination in the shadows, and has led to the adoption of a point of *minimum-useful gradient* on the negative characteristic curve as setting the lower limit of the correct exposure region. For applications of photo-

graphy where the prints are made according to a more or less standard specification (e.g., in motion pictures), the exposure value where the gradient of the curve is some specified figure (e.g., 0.2) is a very useful criterion of speed. Enlarging on this idea, Jones (*ibid.* 1939, 227, 297, 497) proposed that the speeds of negative materials should be based on the minimum exposure required to yield a "first excellent print," as picked out by a panel of observers. For various materials the negatives which yielded this first excellent print were found to have the common sensitometric feature that the ratio of the minimum gradient in the shadow region used in making the print to the average gradient of the utilised portion of the characteristic curve was approximately constant and equal to 0.3. The correlation thus found between the purely sensitometric *fractional gradient speeds* and the print-judgment speeds was checked on a large number of other materials exposed to scenes of varying brightness and developed to differing degrees, and also compared with the correlation between the print-judgment speeds and other previously proposed sensitometric criteria (e.g., fixed threshold, fixed minimum gradient, inertia). The spread of log  $E$  values between the statistical print-judgment method of determining speed and the various sensitometric methods showed that the fractional gradient criterion applied to these materials agreed most closely with print judgment.

The Effect of Development.—Increasing the time of development, or using a stronger solution or a higher temperature, has as its main result on negative materials, an increase in the gamma of the g. and D. curve. This is best shown by drawing the family of characteristic curves for various times of development (Fig. 5). The slopes of the individual curves of the family may then be read off and a  $\gamma$ -time curve drawn. The fog can also be read on an unexposed portion of the material and the fog-time curve drawn. The  $\gamma$ -time curve flattens out to a maximum known as  $\gamma^{\wedge}$ , which is one of the inherent properties of the particular material, determining its usual application in photographic practice. Very high values of  $\gamma^{\wedge}$  are common in the slow materials sold for making line blocks (e.g.,  $\gamma_{cc} = 5$  or more). On the other hand negative materials for portraiture may have a  $\gamma^{\wedge}$  of 1.6 approximately. Hurter and Driffield found that the straight-line portions of the family of curves, if produced to cut the log  $E$  axis, all met it at a point which they regarded as an invariable characteristic of the emulsion and therefore a suitable means of giving it a unique speed number. With modern materials and developers containing some free bromide, the straight-line portions, if they intersect at a common point at all, intersect well below the log  $E$  axis. The result is that on an inertia basis the apparent speed of the material increases markedly as development is prolonged. This is also true to greater or less extent with all criteria of speed hitherto proposed, the result being that there is no unique speed figure for a given photographic material. Such a figure can only be given when the manner of development is specified.

## POSITIVE MATERIALS.

While the shape of the characteristic curve of opaque positive materials is similar to that of negative materials, various new factors are brought into play which ensure that nearly the whole range of the curve must in fact be used. While the highest light on a positive transparency need not be dear, as its brilliance can be increased to any desired extent by putting more light behind it on a paper print the highest light must in general differ little from the white diaphragm. This means that the toe of the positive characteristic is fully used. Satisfactory discrimination of tones in the high-lights of the print, where the slope of the positive characteristic is low, requires therefore that the contrast of the well exposed portions of the negative should be high, compared with the contrast of the less exposed portions which are printed at a density level represented by the steeper part of the positive characteristic. This result is achieved by exposing in the category so that the

toe end of the negative characteristic is used, and is one reason for preferring negative materials with a long toe. Such materials indeed give their best prints on chloride, contact papers which have a markedly bowed characteristic.

Furthermore, the brightness range of tones in an average scene (e.g., 160:1 for an amateur snapshot of nearby objects) requires that the deepest shadows on the print shall approach the maximum black of the paper. Even BO, a considerable compression of tones is unavoidable since the maximum black attainable rarely exceeds a reflection density of 2.0 (i.e., a brightness range of 100:1). This is due to the reflection of light from the grains themselves and from the outer face of the paper emulsion layer. The maximum black is highest for glossy papers (1.7-2.0), intermediate in value for semi-matt or lustre papers (1.4-1.7), and low for matte papers (1.1-1.4). As negatives may differ very considerably in their density range, depending on their development, their exposure, and the

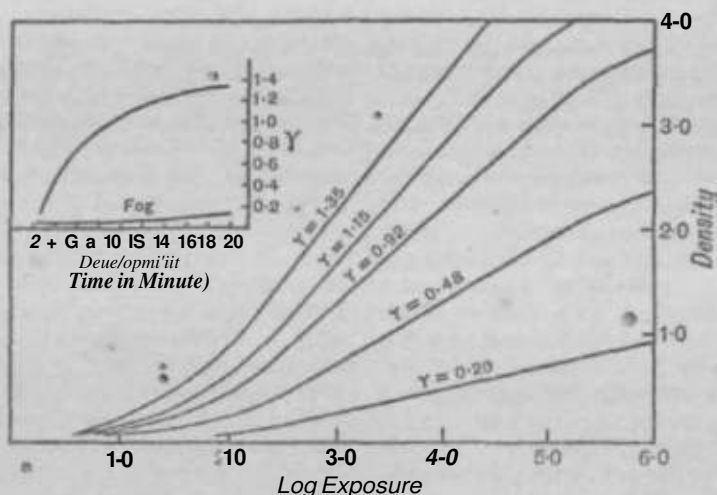

FIG. 5.—FAMHA' OF CHARACTERISTIC CURVES WITH CORRESPONDING  $\gamma$ - $t$  AND Fog- $t$  CURVES.

brightness range of the scene, it is necessary to select for each negative a paper the exposure scale of which (i.e., the range of exposures which just yields the maximum range of distinguishable tones of which it is capable) fits the density range of the negative. For this reason printing papers are made in as many as six grades of contrast, and are selected to fit the negative by judgment from its visual appearance or by trial and error. Research based on a statistical study of print preferences has shown that the effective exposure scale of a paper must be measured between two points on the toe and shoulder of its characteristic where the gradient, multiplied by the gradient of the negative with which it is used, is approximately constant. This means that acceptable shadows and high-lights show a similar differentiation of tones on all prints, no matter on what grade of paper they are made.

In contradistinction to negatives and positive transparencies, the contrast of prints can be controlled but little in development. Chloride and chloro-bromide papers have high rates of development, the curve of maximum slope being

reached in a minute or less. Development\* for longer times than this brings in fresh tones in the highest lights by regression of the inertia, while the dark tones in the deepest shadows disappear progressively into the maximum black. The result is that the print darkens steadily as though it had had more exposure, while sensitometrically the curve moves backwards along the log exposure axis without alteration of slope. The printing exposure latitude thus introduced is of the greatest value in the commercial use of such papers. With bromide papers the slope of the curve does increase simultaneously with regression of the inertia, but the production of soft prints by wider-development is little practised, due to the ready production of streaks and poor image colour.

## SENSITIVITY TO COLOUR.

The absolute and relative sensitivity of photographic materials to coloured light is of importance not only in colour photography (Section VII), but determines also the acceptability of monochrome prints, since the trans-

lation of the coloured tones of the original into monochrome depends on this spectral sensitivity, however it may be modified by a light-filter placed over the lens. Moreover, the design of the spectral transmission of safe-light screens requires a knowledge of the spectral sensitivity.

Sensitometers are of three types, depending on the precision required. For the highest precision a double monochromator isolates a narrow spectral band of great purity and projects it on the material after modulation in some standard sensitometric manner, the chief aim being to exclude all light from other parts of the spectrum. The relative energy falling on the material in the different parts of the spectrum is then measured by a thermopile, and related to the corresponding densities. For standard routine tests of less precision the *wedge spectrograph* is widely used. This instrument projects a complete spectrum on to the material, the intensity of the coloured light being modulated in a direction at right-angles to the wave-length scale by a neutral wedge placed over the slit. On development a wedge-spectrogram is obtained, the ordinate at every wave-length to the edge of the blackened area (*i.e.*, a certain low fixed density), representing the logarithm of the sensitivity to light of that wave-length, as modified by the spectral distribution of the energy radiated by the light source. Much of the usefulness of the wedge spectrogram is due to its automatic combination of the effects of spectral emission of the source and spectral sensitivity of the material, thus reproducing the conditions of practical use. In the third class are step tablets parts of which are covered with coloured filters, *e.g.*, the tricolour red, green, and blue-violet filters of colour photography. The relative sensitivity of the material to light passing through the filters is evident on comparison of the step wedges produced under each filter, and can be calculated the filter factor.

The manner in which the photographic emulsion adds radiation of different wave-lengths has been the subject of notable investigations (Van Kreveld, *Z. wiss. Phot.* 1934, 32, 222; Webb, *J. Opt. Soc. Amer.* 1936, 26, 12). Van Kreveld's addition law for radiations applied simultaneously may be stated in the form

$$S(D, X_n) h_n t = 1,$$

where  $h_n$  represents the intensity of the component radiation of wave-length  $X_n$  in the mixed exposure and  $S(D, X_n)$  is the sensitivity of the emulsion to energy of wave-length  $X_n$  expressed as the reciprocal of the energy required to produce a given density  $D$ . With the sensitivity expressed in this way, the law merely states that the emulsion adds radiation of different colour falling on the material simultaneously for the same time in the same manner as it adds radiation of identical spectral quality. The law also holds for successive exposures to radiation of different colour, provided that the intensities are adjusted to give equal photographic effects in equal times. As a corollary, the reciprocity failure curves of an emulsion are the same for all qualities of radiation, when compared on an equal time basis. The addition law is an expression of the fact that, provided that the rate

of production of photo-electrons is the same? the photographic emulsion grain is indifferent to the quality of the radiation producing the effect.

Limitations of the Photographic Process.—Apart from the absence of colour and the frequent distortion of perspective due to the eye not being in the equivalent position of the taking lens when viewing the print, the main defect of prints made to the highest standards of which photography is capable is the compression of the brightness range of all subjects to a maximum of some 60 to 1. «To attain this range, some parts of the toe and shoulder of the positive characteristic must be used, and even though the defects so introduced are compensated to a great extent by suitable choice of the region of the negative characteristic utilised, the high-lights and shadows of the print are more compressed than the middle tones. In good quality prints this relatively greater compression of the high-lights and shadows is small. Further distortions of the reproduction are due to subjective factors. While it has been shown that the generally much lower illumination of prints, as compared with the original scene, produces little distortion, a subjective factor known as the constant-brightness effect is rarely operative in the reproduction to the same extent as in the original scene. This is the faculty by which the mind appreciates the constant reflectance of an object, say a wall, parts of which are in light and other parts in shadow, whereas in the reproduction the shadowed portions often have the appearance of a reduced reflectance as though darkened by stains. Professional portrait photographers have by long experience learnt to counteract this effect by adding additional light to the shadows (see Evans, *ibid.* 1944, 34, 533).

It needs to be added that many of the limitations of prints do not apply to positive transparencies. Here the brightness range can easily be made equal to that of the original scene, since the high-lights can be raised to any desired brightness by increasing the illumination. Moreover, in both negative and positive the use of the toe and shoulder of the characteristic curve can be avoided, and the straight line portion only used. Given, therefore, a darkened room for viewing and a uniform light-source of sufficient brightness and area, the objective reproduction can be exact. Attempts to realise these conditions by projection, however, introduce new distortions in the shadows due to flare light in the projection lens and scattered light returned to the screen from the theatre walls.

## VI. THE REPRODUCTION OF PHOTOGRAPHS.

While the bulk of positive photographic prints is nowadays made on the silver halide developing-out papers described above, this is a comparatively modern practice which owes its vogue to their convenience and speed (allowing of print making by projection). At one time the greater part of professional portrait negatives was printed by contact on direct print-out papers, in which the image visibly formed by light action was simply toned and fixed. For some 40 years (1850-90) almost all photographic



printing was done on albumenised paper. This was a smooth rag paper sized by floating on a solution of egg albumen containing sodium chloride and citric acid, and was sensitised before use by floating on a bath of silver nitrate. It was replaced gradually by factory-made print-out papers in which a gelatin or collodion vehicle carrying silver chloride (or sometimes bromide or phosphate) together with silver citrate, tartrate, or oxalate and an excess of silver nitrate was applied without washing to baryta-coated paper. The print-out images on these papers have to be toned with gold either before fixing or simultaneously with fixing, in order to yield a satisfactory image colour. The baths used usually contain a soluble thiocyanate or thiodine in addition to gold chloride. Self-toning papers, containing salts of gold, are also manufactured. These tone to a pleasing colour on immersion in the fixing bath.

Printing processes based on the light sensitivity of dichromated colloids form the foundations of photo-mechanical block making and are most conveniently described under that heading below. The same principle, however, is used in a number of processes for making paper prints which still enjoy a limited use, particularly for exhibition work. They have the disadvantage that the speed is not high enough to permit of the making of prints by projection so that negatives of large size must be specially made. All the processes depend on the tanning of a layer of dichromated colloid (*e.g.*, gelatin, gum, shellac) in those parts of the picture exposed to light. The image is formed by using in various ways the differing properties of the tanned and untanned regions. Thus methods based on the solubility of the untanned portions of a gelatin layer in warm water yield a positive image if the remaining tanned relief is darkened by dyeing, or by the uniform inclusion of an insoluble pigment in the gelatin from the outset (carbon printing, J. W. Swan, 1864). Both methods fail unless the exposure is made through the support, or the layer transferred to a temporary support for development. Without these precautions the layer of soluble gelatin next the support dissolves and the image disintegrates. The colours of prints thus made can be very various and the pigments used in the carbon process can be extremely permanent. The gum-dichromate process works on similar principles, but due to the solubility of the gum arabic in cold water the dichromate sensitiser and pigment is mixed with it before it is spread on paper and development is done in cold water. The process lends itself to artistic interpretations as certain tones can be lightened by hastening the development in those regions and others darkened by adding pigment taken from the margins of the print and by multiple-printing from the same negative.

Alternatively the different swelling properties of the tanned and untanned regions may be utilised to form an image without actual removal of any gelatin in warm water. Some dyes have the property of penetrating only in the untanned portions (Pinatype), thus yielding a positive from a positive transparency. If sugar is included in the dichromated gelatin, the untanned

portions remain sticky and can be differentiated from the exposed portions by dusting a dry powdered pigment (*e.g.*, graphite or metal) on to the swollen relief. Of more importance are those printing methods which utilise the properties of the swollen relief to form an image in greasy ink (oil printing). Here the tanned portions accept the ink while the swollen water-saturated untanned portions do not. The inked relief can be used as a printing plate, and the image transferred to unsensitised paper of suitable surface in a press (oil transfer), or to a lithographic printing surface (litho transfer).

The speed of silver-halide emulsion-coated papers is combined with the permanence and means of artistic control afforded by the above pigment processes in a number of procedures which utilise the reducing powers of the silver image to tan gelatin locally by the reduction of dichromate uniformly dispersed in it. In these processes the finely divided silver of the image is used simply as a chemical reagent to give a final picture similarly distributed but in some quite other pigment. Thus the carbon tissue (*i.e.*, the paper coated with a pigmented layer of soft gelatin), which is used for carbon printing after sensitisation in a dichromate solution as described above, may be insolubilised image-wise to yield an almost identical final result by bringing it into contact with a wet bromide print, the carbon tissue having first been soaked in solutions of potassium dichromate and ferricyanide. The ferricyanide oxidises the silver image and is itself reduced to ferrocyanide, and this diffusing back into the carbon tissue reduces the dichromate which tans the gelatin locally just as if it had been affected by light. The carbon tissue can then be applied to a final support and developed in warm water as in carbon printing. This process, known as Carbro, works best if the bromide paper used has no gelatin supercoat, which, if present, necessarily softens the definition slightly. By similar methods the gelatin of a silver bromide paper specially made with soft gelatin may be tanned locally in proportion to the silver image and the resultant relief inked up with a greasy ink. This inked image, when dry, may be used as the final print (Bromoil) or transferred to another surface in a transfer press (Bromoil transfer).

#### PHOTO-MECHANICAL PROCESSES.

While the tanning action of reduced dichromates is little used for print making except by amateurs (and in colour printing as described in Section VII), it lies at the base of the photo-mechanical industry. The preparation of metal printing-blocks from photographs is effected in all processes by the aid of a photographically prepared stencil or resist, which controls the action of chemical baths on the metal according to the lights and shadows of the image. The direct action of light on dichromated colloids (gum, albumen, gelatin, shellac) was until recently almost the only method used for making such resists. New methods based on the tanning action of specially compounded developers at the sites of development in silver halide emulsion layers coated on metal have made progress only within the last few years.



They enable images to be printed on metal directly by projection.

Printing blocks, whether made by photography or otherwise, may be put into one of three classes depending on the method of transfer of the ink to the paper in the printing press. Relief blocks carry an ink film on the raised portions of the printing surface and transfer it to the paper on contact (letterpress printing). Intaglio blocks carry the ink in hollows etched or engraved in a smooth surface, the non-printing areas being cleaned by a doctor blade. In the planographic processes, the printing surface is substantially in one plane, those parts which carry the ink having been chemically modified so that they accept a greasy ink, while the non-printing parts reject it. For all these processes means have been devised to distribute the printing surfaces on the block by photographic means from a photographic original. By various procedures the block may be made to yield an apparent continuous gradation of tones, so that photographs both in monochrome and colour may be reproduced in the large numbers characteristic of the printing press.

The line block consists of an etched plate commonly of zinc in which the non-printing areas have been etched to a depth of about  $\frac{1}{16}$  mm. below the lines by successive "bites" in dilute nitric acid solutions. The action of the mordant on the printing areas is prevented by a stencil prepared photographically. The plate is coated with dichromated albumen, which is then insolubilised in the lines of the drawing by printing under a line negative made from the original artist's drawing. The exposed plate is inked up uniformly with a greasy ink, giving a thin discontinuous coating, and then developed in cold water by swabbing. The water dissolves the unexposed albumen and disperses the ink film. The top of it, parts of the latter being carried by the ink to the lines, thus strengthening the ink film. The resist is further strengthened by dusting a powdered fusible resinous material onto the plate. This adheres only to the inked lines, and is incorporated into the ink by heat. After retouching and cleaning, the plate is ready for etching. To prevent undercutting of the lines by the nitric acid, the sides of the lines are protected at intervals by rolling up the plate with *etching ink* and causing the ink to flow down the sides of the lines. The parts which are to be etched are prepared with gum arabic solution in the manner described under lithography so that they repel the greasy ink. The reinforcing ink therefore takes only on the lines whatever the depth of etch. Alternatively the sides of the lines may be protected by brushing against them a powdered fusible resin (dragon's blood), which is consolidated in position by heat. An alternative resist that is used considerably is dichromated shellac, which is developed in an alcohol bath.

In photolithography the photographically prepared resist may be used to protect the lithographic surface from grease, in which case the exposure is made under a positive, or from water, when the exposure is made under a negative. Grained zinc is commonly used, and the usual method of working from a negative is

to "print down" the image on dichromated albumen, which after exposure is rolled up with litho ink and developed in cold water, leaving the printing image in albumen and ink. The non-image areas are then prepared so that they reject a greasy ink by means of an "etching bath" which deposits an adhering layer of zinc phosphate, followed by gum arabic solution. The porous layer of zinc salts and gum retains water tenaciously, and if kept moist by the arrangements provided on the press continues to reject the printing ink throughout long runs. The ink in the printing areas is by this method insulated from the metal by the layer of hardened albumen, which may result in breakdown on the press. The direct printing methods from positives avoid this danger. Here the bare metal exposed after development is inked up with the fatty ink, and forms the printing surface, while the resist in the parts exposed to light (i.e., the whites of the positive) is dissolved in dilute acid and the metal thus revealed "etched" and gummed to form an ink-rejecting surface.

It will be appreciated that neither the letterpress block nor photolithography is capable of printing any tone between the white of the paper and the full strength of the ink. Half tones are produced in both processes by dividing up the printed area between black and white on such a small scale that without magnification the tone appears to be uniform. This is done by making what in effect is still a line block from a special *screen negative*, in which the tones of a continuous-tone original are automatically broken up into substantially clear and opaque dots, the relative areas of which (as modified by the etching, etc., carried out on the metal) reproduce on the print the tones of the original. The negative material used is of very high contrast and is placed in the focal plane of the process camera a short distance behind a cross-line screen. This consists of a pair of cemented glass plates, on the inner faces of which is ruled a regular pattern of black lines and clear spaces, the lines and spaces being of equal width. The ruling varies from 50 to 200 lines to the inch, according to the use to be made of the block (e.g., fine book or catalogue illustration, 150 lines; newspapers, 85 lines per in.). The two glasses are cemented together with their rulings at right-angles, and the complete screen is so mounted in the camera that it can be moved backwards and forwards through known distances while maintaining accurate parallelism to the sensitive surface.

In most photomechanical establishments the wet collodion process is still in common use for negative making. While its photographic characteristics of fine grain, extreme density of blacks and high contrast can be readily duplicated in gelatin dry plates, the process retains its hold for reasons of cost and convenience, chief of which is the repeated re-use of the large glass plates on which negatives are made, and the ease with which the collodion film may be stripped and mounted (turned over if necessary) with others on a new glass to form a composite negative. Photographically the essential feature of negative materials for screen negative making is high contrast (i.e., short exposure making).

This means that there is a certain level of exposure below<sup>p</sup> which the plate hardly responds at all, whitest a level slightly above it the plate develops almost its maximum density. Behind each opening in the screen there is a certain locus where the exposure is of this critical value. In the high-lights of the image in the focal plane of the process camera the critical locus will be remote from the centre of the opening in the screen, giving a high proportion of exposed to unexposed emulsion? in the shadows only those portions immediately under the centre of the openings will receive the critical exposure and be blackened. The result is small black dots in the shadows and large ones in the high-lights.

Experimental work by Yule (J. Franklin Inst. 1941, 231, 2>; 1943, 235, 483; 1943, 236, 473) has shown that the distribution of light behind the apertures in the screen cannot be satisfactorily accounted for on the basis of the penumbra theory (*i.e.*, the partial occupation, to an observer at each point of the sensitive layer, of the illuminated lens diaphragm\* by the black lines of the screen) except for coarse screens placed very close to the plate. For normal screen-distances diffraction is involved and the shape of the dots agrees well with that deduced from theory.

The type of screen negative produced differs according to whether it is to be printed typographically or lithographically. For the former the exposure is such that the dots in the high-lights just join at the corners (chess-board pattern). When printed on metal the squares protected by the resist are undercut by the etch until the printing surface is reduced to points. These remain as a light tone even in the highest lights and are necessary to prevent either ink or paper from reaching the bottom of the etched hollows on the press. For the latter, as the lithographic printing plate suffers no undercutting, the clear dots in any part of the negative must not be bigger than the areas required to print.

In both processes the rendering of the tones of the original is not satisfactory unless skilled retouching is done on block or negative by the fine etcher. Distortions of the tone rendering achieved on the negative are known to occur at the later stages of half-tone block making and printing due to the undercutting action of the etch and to ink squash round the dots on the press, but these are of but minor effect compared with the errors of the negative, in which the rendering of high-lights and shadows is much flattened. In the high-lights this is due to an insufficiently rapid growth of dot size with increasing exposure; *e.g.*, on a lithographic negative a tone of density 0.3 on the original is represented by a chessboard pattern of equal black and clear dots, but the black dots must increase from this 50% to almost 100% to represent the whites of the picture, *i.e.*, they must increase from the chessboard proportion to the whole area by a mere doubling of the exposure (*see* Tritton and Wilson, *Phot. J.* 1939, 79, 396; Murray, *J. Franklin Inst.* 1936, 221, 721). No means of achieving this by simple procedures with the cross-line screen of the ordinary type are known, and it is in practice only secured by

the fine etcher on the half-tone block, or by chemical dot retouching applied to the screen negative or positive to be used for photolithography. In these procedures the various tones of the picture are protected in turn by manually applied resists when they have reached the correct dot size, the action then being allowed to continue on the others.

A theoretical solution is available by the use of a properly designed vignetted contact screen. Such a screen has dots graded in density from the centre to the periphery and is used in contact with the photographic plate. By suitable choice of the rate of increase of the density of the dot at each point of its radius the dots printed on the photographic material can be made to increase in size more rapidly at the high exposure end giving the correct tone rendering. Moreover, such screens can be used in the camera with the lens at full (or any other) aperture, thus reducing exposure, and if made on a suitably thin support can be used in a printing frame between a continuous tone translucent original and the photographic plate (for making blocks of the same size). Each such screen, however, can only handle an original of a particular contrast. To avoid the necessity of carrying a battery of such screens, they have been made in a coloured dye so that the effective contrast can be adjusted by suitable choice of the colour of the exposing light (Coppin, *Process Engraver's Monthly*, 1942, 49, 86).

Photogravure.—In photogravure the differentiation between tones is effected by varying the thickness of the film of ink transferred to the paper. Most of such printing is now done from cylinders, which are etched through a photographically prepared resist so as to yield a pattern of minute cells of the same area but of depth depending on the tone to be printed. The deeper cells hold the most ink and yield the darker tones. The resist is prepared from a continuous-tone positive of moderate contrast, which is printed on dichromated carbon tissue so that the most tanned portions represent the whites of the picture. The same piece of tissue is also printed under a photogravure screen. This consists of white cross-lines on an opaque ground, the opaque squares having sides about three times the width of the lines. The tissue is insolubilised under the lines and the thick resist eventually formed at these sites protects the metal of the cylinder (usually copper) altogether from the mordant, thus providing the walls of the cells. The exposed tissue is applied to the copper cylinder, usually by a process known as "dry-lay," in which the face of the dry tissue is brought into contact with the cylinder under pressure by rollers while the line of junction is sprinkled with a limited amount of water. The adhering tissue is then developed in warm water and the paper backing removed, leaving a hardened negative resist on the copper, which is then dried. The cells are etched in the metal by successive immersions in baths of ferric chloride of decreasing concentration. The concentrated solutions employed reach the metal only after first swelling the gelatin resist, a reaction which progresses from the top of the resist toward the metal at a rate determined by

the availability, not of ferric chloride, but of water. The thinnest parts of the resist are therefore penetrated first, where attack on the copper begins long before there is any action in the lighter tones. As the action in each successively lighter tone slows up, the bath of next lower concentration of ferric chloride is taken into use, until the very lightest tones are just etched at the end of some 25 minutes. At this time the lines of the screen have not been penetrated anywhere. The resist is removed and the cylinder cleaned. For long runs it may be chromium plated. On the press the cells are filled with photogravure ink by means of a roller rotating half-immersed in a tray of the ink, or on big presses, by means of sprays in an enclosure known as the ink fountain. The ink is very fluid and is made on a basis of xylene, toluene, or even benzene, and dries very rapidly on the paper by simple evaporation. The excess is wiped off the screen lines by the doctor blade, so that only the ink in the cells is pulled out by the paper. Modifications of photogravure, in which the area as well as the depth of the cells varies with the tone, have been used (inverted half-tone).

It is customary to use different colloids for the different branches of photo-engraving; albumen for line blocks, photo-engraving glue for half-tone blocks on copper (this being subsequently burnt-in to form an "enamel"), shellac for half-tones on zinc (this requires no burning-in), gelatin carbon tissue for photogravure. All are treated with dichromates and are insolubilised on exposure to light. The mechanism of this action is imperfectly understood. The essential feature is the reduction of the dichromate, or of chromic acid, by the light, the reduced oxide being responsible for the tanning, either directly or after combination with excess unreduced dichromate. The potassium or ammonium dichromates are usually employed but mixtures of organic bases (pyridine) have been used in recent years with an advantage in printing speed.

**Plan Reproduction Processes.**—Photographic processes little used in any other direction are employed for plan copying. Here the need for cheapness and convenience in processing outweighs deficiencies of low speed and poor rendering of tones. Foremost are the iron printing processes based on the reduction of ferric salts of organic acids by light. Blue-print paper for making copies from engineers' and architects' drawings is made by impregnating the surface layer of paper with a mixture of ferric salts and potassium ferricyanide, and retains its yellow colour indefinitely if kept dry in the absence of light. On exposure to light under the tracing, the unshielded parts turn bluish or purplish grey, due to the reduction of the ferric salts. The image is developed by washing in water, when the ferricyanide reacts with the ferrous salts to give an image in white lines on a blue ground. In large establishments the printing and washing is done by continuous machinery. Papers containing ferric salts only yield blue lines on a white ground if developed with solutions of potassium ferrocyanide; here the unreduced ferric salts are caused to form the

image. Similarly development of such papers with gallic acid solutions give purplish-black lines on a light ground. The gallic acid for development may be included in the paper as supplied so that water alone suffices for development.

The ferrous salts resulting from the reduction of ferric salts by light have been utilised to produce very fine and permanent images by the reduction of salts of the noble metals. Thus the insoluble ferrous oxalate formed by the action of light on ferrous oxalate can be used to produce images in silver ("Kallitype") or in platinum or palladium. The reduction of the noble metal salt takes place *in situ* as the ferrous oxalate is caused to go into solution in a bath of neutral oxalate. Only one of these processes survives in common use. Sepia photo-copying paper, which is prepared by soaking a translucent paper in a solution containing iron ammonium citrate, citric acid, and silver nitrate, gives an image in white lines on a brown ground, which, after fixation in *hypo* and washing, forms an excellent original for the preparation of further blue-prints.

**Dye-Line Processes.**—A new chapter in plan reproduction processes was opened by Green, Gross, and Bevan (J.S.C.1.1800,9,1001), who first prepared a direct positive photographic paper utilising the destruction of diazonium compounds by light. The substance not destroyed was then coupled with a phenol or amine. Green, Cross, and Bevan used primuline, now obsolete, but their principle of development with an alkaline solution of a phenol survives in some modern processes of the "semi-dry" type. For these processes there is no coupling component in the paper, which contains a stabilised diazonium compound and perhaps a mordant only (e.g., diazotised *p*-aminodibutylaniline, or other diazo-compound with tertiary nitrogen in the para-position, stabilised as a double salt with zinc chloride together with an organic acid and aluminium sulphate as a mordant). The developer contains a phenol (e.g. phloroglucinol, which may be diluted with resorcinol), together with a weak alkali. To be satisfactory for commercial use, such a developer must be stable when exposed to air, and must produce a good dark line showing no bleeding. These two requirements are difficult to satisfy together since the rapid coupling necessary to satisfy the second only occurs in alkaline solution which favours oxidation. Many patents on devices to overcome this trouble exist. One interesting solution (B.P. 425235) uses neutral or slightly acid developers containing salts of weak organic acids with a strong base, e.g., acetates, formates, succinates, malates, citrates, tartrates, etc., together with 10-15% sodium chloride to salt out the azo dyestuff and sharpen the lines. In these "semi-dry" processes the developer is applied in a thin film by rollers and dries in a few minutes.

Papers which are developable "dry" by moist ammonia fumes were introduced in 1920 by Kalle & Co. (B.P. 210862). Their "Ozalid" process used the diazonium compound of 1-amino-2-naphthol-4-sulphonic acid together with a coupler and an acid. In the presence of the

last a diazo-anhydride is produced without coupling properties\*. As soon as the paper is made alkaline by ammonia vapour the diazonium compound is regenerated and coupling occurs? Various other patented devices have been disclosed for the prevention of slow premature coupling. The phenols may be protected by converting them into non-coupling bodies which are split by the alkali into components one of which is the original coupling phenol (e.g., B.P. 282894, 283274). Phloroglucinol, in particular, may be protected by treatment with hydroxylamine, forming triketohexamethylenetrioxime, which is reconverted to phloroglucinol by ammonia (B.P. 294972). Bisulphide addition compounds, cyanhydrides, hydrazones, phenylhydrazones, semicarbazones and the like have also been proposed. As the clear areas of the print suffer a mixture of the coupling phenol and the phenol resulting from the destruction of the diazonium compound, they are liable to darken on keeping. Mild reducing agents are often added to reduce this, e.g., thiourea (B.P. 306408), thiosulphates, formalin, hydroxylamine, aldehydes, etc. (B.P. 294972). Self-developing papers which are developed by water or steam are the subject of patents issued about 1935. In these the coupler is rubbed onto the surface of the dry paper or suspended in a wax coating. Such papers have not come into general use. Papers giving a negative print have been proposed based on the original disclosures of Feer (G.P. 53455). Diazo-sulphonates are mixed with a coupler and the usual accessories and couple readily on exposure to light (B.P. 518129, 518162).

In all these processes the action of light on the diazonium compounds in the presence of moisture is believed to follow the equation:

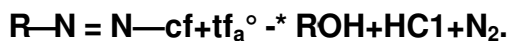

The relative sensitivity of various diazonium compounds has been investigated by a number of workers. One recent research was specifically directed to the comparison of compounds when coated on paper, as in dye line-processes (Brown, Chem. and Ind. 1944, 146). This author established that

1. The light sensitivity of diazonium compounds is entirely in the blue and ultra-violet.
2. For mono-substituted derivatives of aniline, the sensitivity increases in the order para, meta, ortho.
3. The greater the polar strength of a substituent in a diazonium compound, the greater is the sensitivity to light.

Search of the considerable patent literature (some 100 British patents since 1930) reveals that all the practical compounds are made from substituted paraphenylenediamines. Four classes may be distinguished: the diazo anhydrides, the *para* tertiary amino-anilines, the amino-diphenylamines, and lastly a large class of amines with ethoxy side-chains on one or more benzene rings. The various compounds differ in stability, colour of azo dye formed, or printing speed.

While the blue-print and diazo processes still continue to be widely used for plan copying by contact, there has been an incursion of the silver halide processes into the same field in recent years where their speed makes practical new techniques of copying by projection with the aid of a lens. The document may be copied on a considerably reduced scale to form a permanent record, more easily handled and stored than the original, or may be altered in scale only slightly, or not at all. One new application of photography provides means of transferring a full-scale precision drawing (usually on white lacquered metal) direct to the material from which a template or part is to be cut, thus obviating the usual laborious and possibly inaccurate repetition of the draughtsman's work. The material may be sensitised by spraying with liquid silver halide emulsion (in a gelatin, collodion, or synthetic resin vehicle), or may have a factory-made gelatin emulsion transferred to it from a stripping paper (transfer sensitising). In order to print the original drawing on this, it may be made on a special lacquer which is excited to phosphorescence by X-rays or light, the glowing panel then being brought into contact with the sensitised surface. Alternatively the original drawing may be copied in a large precision camera and the negative reprojected through the same optical system on to the new sensitised surface. This method alone allows for alterations of scale.

## VII. THE RECORDING AND REPRODUCTION OF COLOUR.

Sensitisation of photographic silver halide emulsions to light of longer wave-length than the approximate 400 m $\mu$ , 500 m $\mu$ , and 550 m $\mu$ , which respectively mark the limit of sensitivity of pure silver chloride, pure silver bromide, and commercial silver bromo-iodide emulsions is effected by dyeing the grains with certain dyes called *optical sensitisers*, which confer on the emulsion a sensitivity corresponding approximately to their own absorption. This process, which is of the greatest technical importance, not only allows negative materials to record coloured objects in monochrome in relative tones which the eye appreciates as satisfactory, but contributes considerably to the effective speed of such materials, particularly in artificial light, and is indispensable for any process of colour photography. By an extension of the method, it has been found possible to photograph by invisible radiation in the infra-red.

The starting point of these developments was the discovery by Vogel (Ber. 1873, 6, 1302) that certain collodion dry plates, which have been treated with a yellow dye to prevent halation, showed some sensitivity in the green. He examined a number of dyes and found that some of them, notably coralline, sensitised the plate to the green and red. His published results excited considerable attention and led to some systematic investigations of existing dyes, notably by Eder and Valenta. Dyes specially synthesised for use as sensitisers were examined by Miethe and Traube (G.P. 142926, 1902) who found excellent sensitisers for the green and

yellow regions of the spectrum amongst homologues of cyanine which were recognised as being the *isocyanines* of Hoogewerff and Van Dorp (Rec. trav. chim. 1883, 2, 317; 1884, 3, 337). From then on, attention was concentrated on the cyanines, and it is from this class that the best modern sensitisers derive (v. CYANINE DYES, Vol. III, 5146). To these basic dyes must be added the acid dye Erythrosin (Vol. IV, 336a), which has been used since 1884 for sensitisation in the blue-green, and a whole new class of "merocyanines." These are prepared by condensation of various cyanine intermediates with compounds, usually cyclic, containing a reactive methylene group. Like the cyanines, the merocyanines form vinylene homologous series in which the two nuclei may be joined by a double bond or by  $(\text{:CH-CH:})_n$  in which  $n$  is 1, 2, or 3 (B.P. 426718, 428222, 428359, 1933; 450958, 1934; 528803, 1939). The numerous nuclei with reactive methylene groups available enable dyes to be prepared with a powerful sensitising action in any desired part of the visible spectrum.

**The Mechanism of Dye Sensitisation.**—The early correlation between the absorption spectrum of the sensitising dye and the region of induced sensitivity in the silver halide was found to be inexact when closely examined. The sensitisation peak was always displaced slightly with respect to the absorption peak of dye solutions. In view of the changes of absorption exhibited by many (dyes when dissolved in different solvents, it was believed that the sensitising spectra would be found to be identical with the absorption spectra of the dyes as adsorbed to the silver halides. This was proved to be the case for eosin by J. M. Eder ("Beiträge zur Photochemie u. Spectralanalyse," 1904, Vol. III, p. 37) and for the cyanine dyes by Leermakers, Carroll, and Staud (J. Chem. Phys. 1937, 5, 878), but left unexplained the mechanism by which the energy of the light absorbed by the dye was passed on to the silver halide. In attempts to understand this, the nature of the attachment of the dye to the silver halide surface was investigated. Quantitative experiments on the adsorption of various cyanine dyes (Sheppard and Crouch, J. Physical Chem. 1928, 32, 751; Leermakers *et al.*, J. Chem. Physics, 1937, 5, 893; Davey, Trans. Faraday Soc. 1940, 36, 323), showed that many of them gave isotherms with two distinct plateaux, apparently corresponding to the adsorption of successive molecular layers. It is believed that the molecules in the first adsorbed layer are closely packed and lie flat, each covering some 10 Br— ions of the silver bromide lattice. At higher concentrations of the dye a re-arrangement may take place, whereby the dye molecules assume a closely packed edge-on arrangement. With many dyes the onset of this orientation induces a new absorption and sensitisation band, which is often found in water solutions of the same dyes, and is believed in both cases to be due to these edgewise-packed aggregates. According to Sheppard, the new band is due to a new resonance system perpendicular to the plane of the molecule made possible by water molecules between the  $\text{N}^+$ -atoms of each overlapping

doublet. Various foreign organic molecule// are known, which depress the new band<sup>1</sup>, presumably by interference with the formation of these card-pack aggregates.

Other agents are known which function as supersensitisers, i.e., they enhance the sensitising action of a dye though they may be themselves without sensitising action. In some cases mixtures of dyes, instead of yielding the depressed sensitivity which is the usual result of the employment of dye mixtures, mutually enhance the action of each other (U.S.P. 2075046-8, 1937).

Two hypotheses are possible to explain the sensitising action of the adsorbed dye. One supposes a direct electron transfer from an optically excited dye molecule to the conduction band of the halide; the other a transfer of excitation energy to a bromine ion of the lattice by resonance, causing it to eject an electron into the conduction band. The weight of expert opinion inclines to the latter view (Mott, J. Phys. Radium, 1946, [viii], 7, 249). It is supposed that there are certain points on the surface of the crystal where the energy necessary to transfer an electron to the conduction band is lower than the 3 e.v. normally necessary. Such discontinuities in the lattice indeed account for the long-wave-length tail in the absorption spectrum of the silver halides. The energy of the excited dye molecule can be passed from neighbour to neighbour in the adsorbed layer some  $10^7$  times before the dye returns to its ground state, during which time there is a high probability that it will reach one of the discontinuities in the lattice where it is transferred to a bromine ion by resonance, which thereupon ejects an electron into the conduction band. On this view dye-sensitisation merely exalts a sensitivity to coloured light present in germ in the undyed silver halide. Sensitisation by transfer of energy can occur only if the dye is adsorbed with a particular orientation to the crystal surface, which in turn requires a particular structure of the dye molecule.

Commercial *panchromatic* plates, sensitised with pinachromo and pinacyanol, were placed on the market by Wratten and Wainwright in 1906, and were the first English plates to give correct rendering with a comparatively light yellow filter. They were little used except for commercial photography of paintings, furniture, etc., where distortions of tone rendering were very obvious, and for early colour photography. Wider use followed the First World War, as red-sensitive plates had been found to be necessary for aerial photography. The motion-picture industry still relied on green-sensitive but not red-sensitive film ("Orthochromatic film") until 1925, when panchromatic film began to be more and more used, a change-over accelerated by the advent of sound in 1928, which abolished the noisy arcs from the studios, and necessitated a red-sensitive film to give adequate speed with the incandescent tungsten lamps which took their place. This film, however, was still sensitised with pinacyanol first produced 24 years before. The new dyes were not introduced commercially until 1931 ("Super-sensitive" panchromatic film), and immediately made studio motion-picture photography much simpler

and opened new possibilities in its scale. This film, and the types which have succeeded it, played a great part in the rise of miniature camera photography (by providing emulsions of fine grain, but with adequate speed conferred by sensitising) and paved the way for the present active developments in colour photography. The new dyes sensitising in the infra-red enabled photographic materials to be made, which, though useful mainly to the scientist and astronomer before 1939, have since been found extremely valuable in war-time, aerial photography. In the laboratory, spectrum lines beyond 1,200 m $\mu$ . are readily recorded while fast and stable materials recording in the range 705-900 *m $\mu$* . are available for camera use.

COLOUR PHOTOGRAPHY.

While the principles of colour photography as at present practised had been outlined clearly long before 1900, the attempts to realise them made during the first quarter of the twentieth century, though highly ingenious and requiring remarkable technical skill in manufacture or use, must be regarded as the unsuccessful forerunners of the processes which will eventually capture the field. The establishment of a large black-

and-white photographic industry during the same period (particularly in motion-pictures) has meant that the successful colour process must be utilisable without radical change in the equipment in common use. Otherwise there is no market for the new material until the potential users have been persuaded to buy the special equipment. This aspect has rendered obsolete many elegant processes in which colour reproduction was excellent, and has directed research to processes which, though very complicated in manufacture, are simple in the hands of the user.

All the processes which have been more than laboratory curiosities reproduce the colour of photographed objects by automatic synthesis from three primaries according to the principles of colorimetry. The reproduced colour is a visual match for that of the object, but may have a very different absorption spectrum. In contrast to these *subjective* processes a few *objective* processes are known which seek to reproduce coloured objects by a reconstruction of the spectrum of the light from those objects, usually by physical means. One of the more notable is the Lippmann process (1891) in which glass plates coated with a grainless (and hence

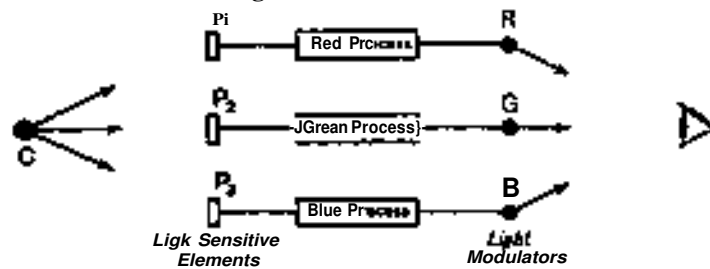

FIG. 6.—ESSENTIAL ELEMENTS IN A THREE-COLOUR PROCESS OF COLOUR REPRODUCTION.

extremely slow) colour-sensitised silver bromide emulsion in gelatin or albumen were exposed through the glass in the camera, the sensitive surface being in contact with a mirror of mercury. Under these conditions standing waves were set up within the emulsion layer, resulting in the formation of latent image in layers between the nodes. After development the lamina of silver so produced lay apart in a position to reflect light of the same colour as that by which they were formed, since light of that colour only was reinforced at each partial reflection, light of all other wave-lengths being destroyed by interference. The plates were seen as coloured positives when examined by reflection before a dark background. They could not be copied. The micro-dispersion methods, in which the light from each point of the object was dispersed into a micro-spectrum on the plate, have similarly never emerged from the laboratory.

The subjective processes synthesise the reproduced colour by mixing coloured light (or equivalently, subtracting unwanted colour from white light) in proportions determined automatically at each point of the image by the relative densities of three photographic separations. The principles can be properly under-

stood only by reference to the science of colorimetry, which is based on the same experimental facts of colour vision.

The fundamental observation on which colour reproduction is based is that any colour can be matched by a suitable mixture of three selected radiations. The problem therefore divides itself into two aspects, the *analysis* of the original scene colour into three components or separations, and the *synthesis* of the reproduced colour by some suitable method in which the separations are used to modulate the respective amounts of three synthesis radiations. The principles are conveniently set out in a diagram (Fig. 6) due to Wright, the scene being photographed, and P<sub>1</sub>, P<sub>2</sub>, P<sub>3</sub> are the three photographic sensitive surfaces, which are distinguished from one another by their spectral sensitivities, as conferred on them by the combined effects of their inherent colour sensitivity and a suitable colour filter interposed between them and the incident light. For satisfactory reproduction of natural colour P<sub>1</sub>, P<sub>2</sub>, and P<sub>3</sub> between them must cover most of the visible spectrum, and we will assume that P<sub>1</sub> has its maximum of sensitivity in the red, P<sub>2</sub> in the green, and P<sub>3</sub> in the blue. The records made on P<sub>1</sub>, P<sub>2</sub>, and P<sub>3</sub>, which to a first approximation

may be regarded as records of the red, green, and blue light in that point of the object, are then caused by a suitable optical or chemical process to affect the reproduction modulators, R, G, and B, which respectively modulate the red, green, and blue light reaching the eye from an external source. In colour photography, this analysis and synthesis is effected independently for each point of the picture, the geometrical relations of one point to another being preserved throughout by the photographic nature of the processes.

It is convenient to consider the synthesis of the reproduced colour first. For simplicity, an additive process, in which light deriving from what are effectively three independent coloured sources reaches the eye after modulation by the photographic separations, is first described. The conditions under which a subtractive process, in which light from a single source reaches the eye

reasons of computational convenience which led to their adoption, need not be considered. Suffice it to say that all real colours are represented on the chart by the area bounded by the spectrum locus, and the straight line joining its two ends. The geometry of the diagram is such that the result of any additive mixture of two chromaticities  $o$  and  $o'$  must necessarily be represented by a point on the straight line joining  $o$  and  $o'$ , and similarly, any additive mixture of three chromaticities  $B$ ,  $o$ , and  $B$  is represented by a point inside the triangle  $ROB$ . The choice of the synthesis stimuli  $E$ ,  $G$ , and  $B$ , in a process of colour photography, must combine satisfactorily appropriate conditions of gamut, brightness, and practicability. In order to reproduce as great a range of colours as possible, the area of the triangle with apices  $a$ ,  $o$ , and  $B$  should be as large as possible, provided that colour filters of the chosen chromaticity are practical, by reason of the existence of dyes of the required colour and stability, and are not so dark as to make the reproduction process very extravagant in light. In practice, since saturated blue-greens are rare in nature, the synthesis

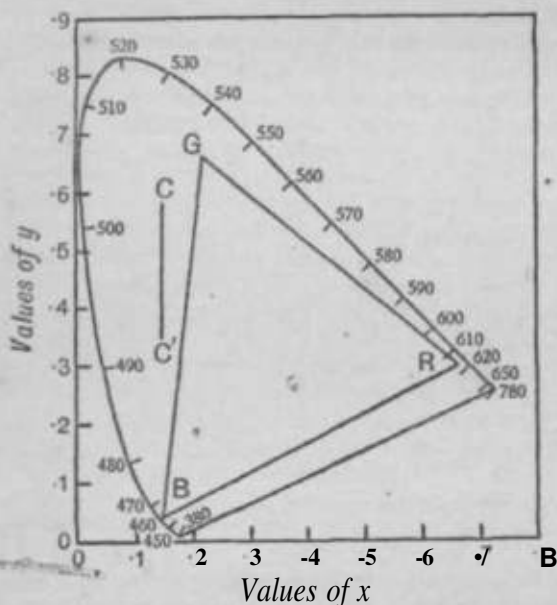

FIG. 7.—CHROMATICITY DIAGRAM SHOWING GAMUT ENCLOSED BY ADDITIVE STIMULI R, G, AND B.

after successive subtractions of unwanted radiation from it, becomes equivalent to an additive process, are then stated, and the manner in which known subtractive processes fail in this equivalence is described. Means by which the limitations and errors of subtractive processes may be reduced are briefly outlined. The whole is discussed with reference to the chromaticity diagram of colorimetry.

The chromaticity diagram (Fig. 7) is a development of the colour triangle of Maxwell and represents by its geometrical properties the experimental laws of colour mixture. The chromaticity of a colour  $c$  is represented on the diagram by a point whose co-ordinates  $x$  and  $y$  and  $z$  where  $x+y+z=1$  are derived by a linear transformation from the scale readings of a trichromatic colorimeter, the reference stimuli of which have already been evaluated in terms of the XYZ system. The actual nature of the conventional  $X$ ,  $Y$ , and  $Z$  stimuli set up by the Commission Internationale de l'Éclairage, and the

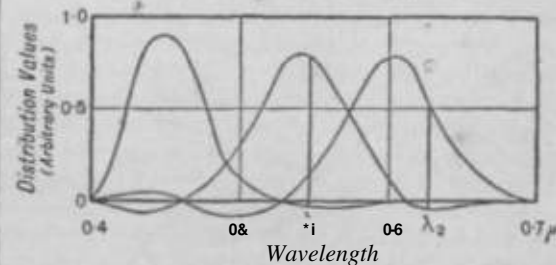

FIG. 8.—DISTRIBUTION CURVES COMPUTED FOR REAL ADDITIVE STIMULI R, G, AND B.

green may be considerably desaturated. Saturated reds and yellows, however, are common, and the EG side of the colour triangle must not lie very far from the spectrum locus. The diagram shows the approximate position of synthesis stimuli which have been recommended in practice. The synthesis stimuli having been chosen, it is possible to calculate the theoretical spectral sensitivities of the analysis systems  $r_r$ ,  $r_g$ , and  $r_b$  which will ensure correct reproduction of all chromaticities inside the triangle  $ROB$  (Hardy and Wurzburg, J. Opt. Soc. Amer. 1937, 27, 227). The distribution ( $\bar{x}$ ,  $\bar{y}$ , and  $\bar{z}$ ) curves of the C.I.E. reference stimuli  $x$ ,  $Y$ , and  $z$  for the standard observer and the equal energy spectrum have been established, and can be transformed by purely algebraic processes to refer to the actual chosen stimuli  $a$ ,  $o$ , and  $B$  used in the additive synthesis. The graph obtained, which is of the form shown in Fig. 8, represents the relative amounts of  $E$ ,  $a$ , and  $B$  required to match each wave-length of the equal energy spectrum. An additive mixture of all the spectrum light between wave-lengths  $\lambda_1$  and  $\lambda_2$  will be matched by amounts of  $R$ ,  $G$ , and  $B$  represented by the areas under the curves between the wave-lengths  $\lambda_1$  and  $\lambda_2$ . Any additive mixture whatever will be matched by amounts of  $R$ ,  $G$ , and  $B$  represented by the areas under the curves, due account being taken of



negative portions, if the ordinates of the curves are List multiplied; wave-length by wave-length by the corresponding ordinates of the spectral energy curve of the source to be matched. If, therefore, the spectral sensitivities of  $T_V P_2$ , and  $P_3$  correspond to the distribution curves of R, O, and B, and the link between them and the modulators of R, G, and B is linear, coloured light will produce an effect in  $r_v$ , etc., corresponding to the areas under the curve, which translated into a modulation of B, O, and B by the appropriate linear linkage, will reproduce the colour for the standard observer.

Errors arise from the lack of correspondence between the spectral sensitivity curves of available photographic systems (emulsion plus filter) and the theoretical curves, and from the lack of linearity in the linkage. In particular, the practical impossibility of realising photographic recording systems which respond in a negative sense to spectral radiation over the wave-length range in which the distribution curves are negative, causes errors in the reproduction of all colours (including those within the triangle BOB) which have light of these wave-lengths in their composition. Detailed colorimetric analysis enables the nature and degree of the errors in the reproduction to be worked out, and reveals the possibilities of playing off one type of error against another. Most of the errors result in a desaturation of the colours of the reproduction as compared with the original (Wright, Phot. J. 1940, 80, 25).

The additive processes reproduce the subject by the addition, at each point of the image, of appropriate amounts of light of the colours R, G, and B. The subtractive processes achieve the same result by the superposition, at each point of the image, of selectively absorbing substances which remove from an otherwise uniformly illuminated white background the appropriate amounts of light of the colours B, G, and B recorded by the absence of deposit in the colour separation negatives. Analysis is conducted in the same manner as for additive synthesis, and each separation negative is then printed (i.e., its shadows are reproduced) in a colour complementary to the taking filter. The red separation negative is printed in cyan (minus red), the green separation negative in magenta (minus green), and the blue separation negative in yellow (minus blue). The three prints are then superposed. For the system to be equivalent to additive synthesis, the three dyes or pigments used must be (a) independent of each other, i.e., each dye must control its own strip of spectrum with no absorption in those parts of the spectrum controlled by the other dyes; (b) stable, i.e., the chromaticity of the equivalent absorbed additive stimulus must remain constant for all densities of the minus colour; and (c), the dyes between them must be capable of reproducing the required gamut of colours including black. These three conditions require that the spectral reflectance or transmission of the ideal dyes should be as represented in Fig. 9, the boundaries of the absorption curves being so chosen that the chromaticity of the absorbed spectral band is that of  $B_y O_y$  or B.

Dyes of the ideal spectral absorption do not exist, lack of colorimetric compliance with conditions (a) and (b) being the chief defects. Non-compliance with condition (a) can be remedied to some extent by masking, in which the undesired adsorption of one minus colour is compensated for by reducing the amount of another minus colour printed at the same point. The undesired blue absorption of the magenta dye, for instance, can be compensated by reducing the amount of yellow printed at all points where magenta is printed, the reduction being proportional to the amount of magenta. This is

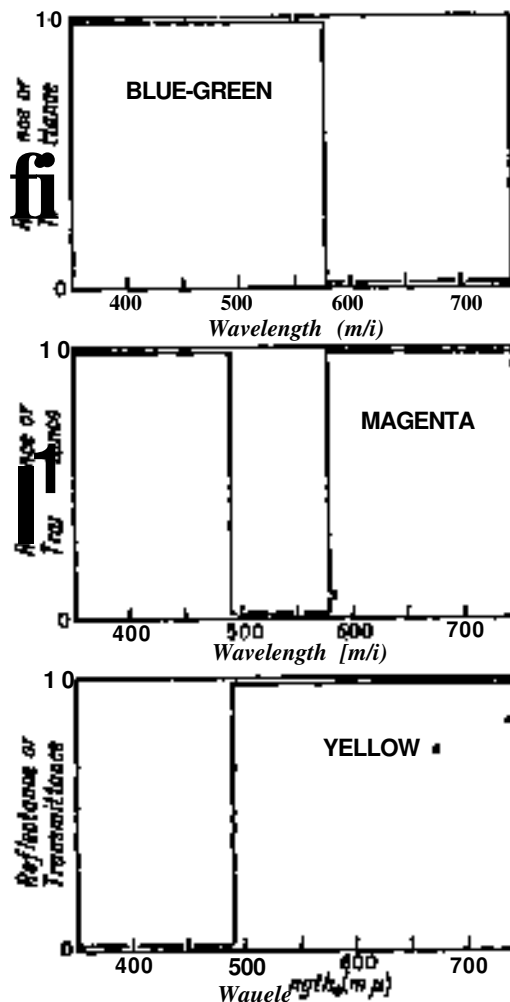

FIG. 9.—IDEAL REFLECTANCE OR TRANSMITTANCE CURVES OF SUBTRACTIVE COLOURANTS IN FULL CONCENTRATION.

done by binding up a positive mask made from the green filter negative with the blue filter negative before making the yellow print. Similarly the unwanted green absorption of the cyan dye can be compensated by reducing the amount of magenta. The compensation fails, of course, where it requires more than the total removal of the yellow or magenta, e.g., in areas where the colours of the subject are more saturated than can be matched by any one of the three dyes or their combination in pairs. For many subtractive printing colours, equivalent additive stimuli can be identified such

that the unwanted absorption of those stimuli by the other two dyes is proportional to the concentration of these dyes, for all useful concentrations of the dyes. Suitable masking then compensate for this unwanted absorption then effectively realises stable stimuli, and the subtractive system becomes equivalent to the additive system. In many cases the equivalent additive stimuli of a set of subtractive printing colours, so chosen, lie outside\* the gamut of physically realisable colours, and may reduce the negative portions of the B, o, B distribution curves to negligible proportions (McAdam, *J. Opt. Soc. Amer.* 1938, 28, 466).

In addition to the reproduction of chromaticity, the successful process of colour photography must also reproduce relative brightnesses correctly, an aspect not covered by discussions based on the chromaticity diagram. In general, the same conditions which assure correct tone reproduction in black and white photography (Section V, p. 566a) are required also in colour photography. Many of them, as for instance a linear relation between exposure and the final modulation of light in the reproduction, are required also for the correct reproduction of chromaticity. Even when the colour photograph is produced, various psychophysical aspects of vision operate to reduce or enhance its resemblance to the original scene; e.g., the state of adaptation of the eye, the existence of a reference point, such as a white border to a colour print, etc. These are discussed by Evans (*ibid.* 1943, 83, 579).

**Practical Colour Photography.**—All colour processes effect in some manner the above three-colour analysis and synthesis, processes being judged by their convenience in use and the quality of the results they produce. Subtractive synthesis is usually preferred for transparencies and is essential for prints in order to <sup>^J^ftj^a</sup> a sufficiently bright image for viewing under normal lighting conditions, although it is more difficult to reach the standard of colour reproduction attained in the additive processes. Modern processes may be classified according to whether the three-colour analysis is performed by the use of adjacent elements of time, of area, or of depth. Each system (discussed in turn below) has its characteristic advantages and disadvantages, progress in the art consisting of a reduction of the latter while retaining the former.

**Analysis by Successive Exposures.**—For stationary objects, three exposures can be made in succession to produce the separation negatives on three distinct areas of negative material. Suitable clock or motor-driven mechanisms may reduce the total exposure to a value where it becomes practical for portraiture. The process fails for faster-moving objects and cannot be used in its mechanised forms except by the purchase of the specialised equipment, which is rarely very portable. On the other hand, the three negatives can be handled separately by the ordinary processes of black and white photography and (with a properly computed lens) at all of the same size.

**Analysis by Use of Adjacent Areas.**—Three-colour cameras, in which light beams from the

object are diverted by beam splitters to three separate areas of sensitive surface, each with its appropriate filter, have provided a fertile field for inventors and modern examples of such cameras are practical, if expensive, pieces of apparatus. Commercial examples all have the beam-splitting partial reflecting mirrors behind the taking lens. The overall speed is apt to be slow, since only part of the light traversing the lens reaches each taking filter, where it is again reduced. The negatives may also suffer from colour wedging due to alteration in the reflectivity of the mirrors at different angles of incidence. The use of pellicle mirrors, and of reflectors so treated as to have preferential reflection for chosen spectral region, while remaining transparent to the others, are comparatively recent advances.

The mosaic screen processes provide an elegant solution to the problem of simultaneous analysis and can be very simply reversed (Section III, p. 563c) to yield a coloured picture by additive synthesis. Their simplicity, and the fact that they can be used in ordinary cameras, have assured them of a steady market. The materials consist of a reversible panchromatic emulsion coated on a mosaic screen made up of juxtaposed minute areas of taking filter. The elementary areas are too small to be resolved by the eye in normal vision, and the screen appears as a grey, being an additive mixture of the colours passed by the filters. On exposure through the screen, the latent image produced under the totality of elements of any one colour, say red, is a (broken) separation record for that colour, and similarly for the two others. The screen is so fine that it does not significantly interfere with the resolution, for unaided inspection. On reversal, additive synthesis occurs, since each broken filter becomes in effect bound up with a black positive made from the equivalent separation record.

In an ideal additive process, as long as the points on the chromaticity diagram representing the viewing stimuli enclose the required gamut, the spectral distribution of the light passed by each is immaterial. Not so with the taking filters, which should be such that the effective spectral sensitivity of the emulsion-filter combination corresponds with the observer's colour mixture curves for the chosen viewing stimuli (and will involve unrealisable negative portions). Where the viewing and taking filters are the same, as in the reversible mosaic screen process, detailed colorimetric analysis enables the best compromise curves to be deduced, and the errors resulting from the neglect of the negative portions to be evaluated (Harrison and Homer, *Phot. J.* 1937, 77, 706). In general, the theoretical requirement that the taking filters shall have large overlaps in their curves of spectral transmission results in viewing filters less saturated than is desirable. The compromise restores the saturation by limiting the overlaps, with a consequent reduction in hue discrimination (for coloured light consisting of narrow spectral bands).

The manufacture of the commercial mosaic-screen process materials is in many ways a technical triumph. The screens may be irregular,

and made by dusting a mixture of coloured particles (*e.f.f.* starch, gums) on to a tacky surface, followed by rolling; or may be regular, the three colours being distributed in a repeating pattern\* by photomechanical or printing techniques. Although the individual elements of irregular screens may be much smaller than the corresponding elements of regular screens, chance aggregates of elements of like colour may make the presence of the screen <> more noticeable. Screens made to a very precise regular pattern\* on rigid supports may be used in conjunction with a separate panchromatic plate. A normal positive transparency made from this is re-registered with a separate viewing screen.

An elegant optical equivalent of the mosaic-screen process\*, with advantages in ease of manufacture, is found in the lenticular process. The transparent support of a panchromatic emulsion is embossed with minute lenticular ridges on the back, some 20 per mm. The material is exposed in the camera with the emulsion away from the lens, and the lenticulations are so shaped as to image the aperture of the taking lens in the plane of the emulsion. A banded tri-colour filter is placed in the front nodal plane of the lens.

In the camera the main drawing of the image is done by the camera lens, but minute portions of the picture are analysed into three adjacent areas on the emulsion layer under each lenticule. On reversal and projection by means of a similar optical system, the colours are additively synthesised on the screen. In this case the light emerging from the strip corresponding to any one separation is bent by the lenticule so as to fall on the appropriate section of the three-banded filter in the projector lens.

The integral additive systems,\* though lending themselves to simple processing by recognised black and white techniques, are extravagant in light on projection (as in the cinema), since the brightest white cannot be greater than that produced by the sum of the light passing the three unobstructed filters. The degree of enlargement is limited to that point where, the mosaic structure of the material becomes visible. The making of duplicates is attended by great difficulties, either by reason of desaturation due to the overlapping of the spectral transmissions of the filters (so that the effects of the light passing the elements of one colour in the master cannot be confined to the elements of the same colour in the copy), or by the production of moiré\* patterns due to the combination of the two screens. Nevertheless the screen processes have wide use for commercial photography as originals for photomechanical reproduction and guides for the colour etcher. For such uses the practicability of immediate processing in the photographer's darkroom is a decided advantage.

*Analysis in Depth.*—Analysis by means of superposed emulsions, each effectively sensitised so as to record one separation, utilises the taking light with fair efficiency and the superposition of the records is a construction ideally suited for subtractive synthesis of the photographed colour. These advantages have only become accessible within recent years with the successful development of means of processing the individual layers of an inseparable tripack to the

required minus colour. Previous attempts to use tripack constructions which were separated for processing have had little commercial success as they have forfeited the advantage of automatic register while the necessity of supporting each emulsion on a support which would stand the processing operations without distortion has diffused the definition of the rear records. This is the more serious as one of them is the red record printed in cyan, a colour in which lack of definition is readily seen. In a tripack both the green and red sensitive emulsions must be protected from blue light by a yellow filter incorporated in the pack behind the blue sensitive layer, which comes first.

A combination of a bipack with a beam splitter to make the third separation improves the definition as the emulsions of the bipack may be coated on normal support and exposed face to face. The beam splitter is simple as it only involves one mirror, or prism. This system is the basis of "Technicolor" cinematography on the taking side. Its need for a special beam-splitter camera, however, has limited its commercial use substantially to this particular field.

The integral tripack or monopack avoids these difficulties by the use of three differently sensitised emulsions, each some 5/16" thick, on top of one another on the same side of a support. The layers are processed directly to positive coloured part images. The optical contact between them and their small thickness gives good definition, while register is automatic and the complete product usable in any normal camera without change. Given satisfactory speed and colour rendering, these are the ingredients for a commercially successful process, as the processing of the exposures can be done as a factory operation under scientific control, while the final subtractive result requires the purchase of no special viewing machinery or extra light.

Most of the processes on the market\*—time of writing (1945) utilise the technique of coupling colour development for the preparation of the minus-colour positive images in each layer of the tripack. This technique, the chemistry of which is discussed below, produces a &eye image *in situ* with a silver image in a photographic emulsion by coupling the oxidised developer with an added coupler. The rise in the importance, of this process concurrently with the monopack materials is due to properties which make it peculiarly suitable for the production, of colour images' in the inseparable layers of a tripack. These are (a) the possibility of including colourless couplers in each layer before exposure, where they remain harmlessly in wait until coupled with the imagewise produced oxidation products of a single developer applied to all three layers, (b) the convenience of processing a latent or silver salt image to colour in one step, and (c) the immunity of an image processed to colour in one layer from replacement or destruction by different colour-forming agents of its own kind applied for the purpose of colour development in an adjacent layer. The manufacture of a multi-layer monopack material by the successive application of thin red-sensitive, green-sensitive, and blue-sensitive emulsions to a support, with a detachable yellow

filter layer between the blue- and green-sensitive layers, and the balancing of the emulsions for speed and contrast, are difficult but non-novel extensions of black and white practice. It is the differential imagewise colour formation in each layer rendered possible by the properties of colour development listed above which makes the process practicable.

Existing systems may be classified as to whether the couplers are included in the layers during manufacture, or are present in the developing baths alone. The former system facilitates processing as the distribution of the right minus colours to the right layers is automatic on development in one bath. Its successful realisation by the discovery of couplers substantive to gelatin, or by the device of the protected coupler (in which the coupler is dissolved in minute particles of an immiscible transparent organic material dispersed throughout each layer) (B.P. 505834), has involved an enormous amount of research. Without these features the couplers trespass into the wrong layers or are lost in the baths. On the other hand, such bound couplers may be incapable of yielding dyes of such good colour or stability as those afforded by the second system, where both the developing agent and the coupler can be chosen for dye colour and stability without reference to the effects of the chemicals on the keeping properties of photographic emulsions, or the effects of couplers retained in the film on the lights of the coloured picture. With this latter technique the appropriate developers must be made to act in the right layers by the use of baths of limited rate of diffusion, or by the utilisation of the sensitivity of the layers to printing lights, the action of which is confined to the appropriate layer by reason of its colour sensitivity, or by reason of temporary screens between layers produced in processing and provided for in the construction of the film. For the controlled diffusion method, solutions of reagents in organic solvents containing a small proportion of water are applied to the dried film. The water slowly swells the gelatin from the top downwards, the reagents acting only on the swollen layer or layers. The solutions may be developers that act only on the upper layer or layers, or they may be bleachers that remove the incorrect dye images from the upper layer or layers, leaving the lower layers unchanged. The bleach may be designed to convert the silver associated with the dye in the bleached layers to a silver salt which can subsequently be redeveloped to a different colour. For one form of the selective exposure method applicable to reversal film, the sensitisers and filter layer are selected so as to survive the first development. The film is then exposed through the back to red light, which affects the residual silver bromide of the bottom emulsion alone, and is developed in a cyan colour developer. Exposure from the front to blue light follows, followed by development of the residual silver bromide of the top layer to yellow. The middle layer residual silver bromide can then be developed to magenta. Removal of all the negative and positive silver in a bleach which does not attack the dyes completes the process (Mees, *Phot. J.* 1942, 82, 300). These

monopack pictures can be readily duplicate\* 1, or may be used in a negative-positive procedure. In the latter case the colours developed in the varichs layers of the negative need not be complementary to their spectral sensitivity, or the sensitivities of the layers of the print material complementary to the yellow, cyan, and magenta colours developed in them. All that is necessary is that the absorptions of the dyes in the red, green, and blue separations of the negative material should register only in the layers of the print developed respectively to cyan, magenta, and yellow.

A different scheme for obtaining a subtractive colour picture in a monopack material is due to Gaspar, Christensen, and others. This depends on the destruction of uniformly distributed dye in those regions where there is a negative silver image. The presence of a dye in each layer, complementary to the colour for which the layer is sensitised, reduces the speed and contrast, since the light absorbed by the dye cannot contribute to latent image formation. As a remedy for this condition, Gaspar proposed sensitising each layer for a spectral region transmitted by it and by the overlying layers. For example, in one arrangement of a printing material for coating on paper, the top layer was dyed cyan and contained a silver chloride emulsion sensitive to green but not to blue, the middle layer was dyed magenta and contained a blue-sensitive silver bromide emulsion, and the bottom layer was dyed yellow and sensitive to infra-red. Prints were to be made on this paper from a camera material in which the top layer was blue sensitive, but was undyed at the time of exposure, the dye being introduced in the course of processing. This dye was of a cyan colour with considerable absorption in the infra-red. The middle layer was green sensitive and contained a yellow dye; the bottom layer red sensitive with a magenta dye. This camera material was processed to a positive in false colours, which were corrected in the print (*see* B.P. 408991; 409287; 415040; 483366; 485552). Alternatively, colourless dye-formers are added to the layers. The dyes are sensitised uniformly after exposure and then bleached *in situ* with the negative image (B.P. 503873; 488853; U.S.P. 2166049).

#### CHEMISTRY OF VARIOUS METHODS OF OBTAINING MINUS-COLOUR IMAGES.

Coloured prints from separation negatives can be made by a variety of procedures, the final step in each method requiring the superposition of the three minus-colour positives in register on one support. Excellent results have been attained by the use of Carbon and Carbro as outlined in Section VI, the pigment tissues being specially chosen for three-colour synthesis. Unpigmented reliefs prepared by the same reaction, or directly in silver halide emulsion layers by the action of tanning developers, or hydrogen peroxide etch bleaches, or by the reduction of dichromates by the developed silver, are used in transfer or imbibition printing to transfer a regulated amount of dye to a final support. Except for the etch-bleach method, in which an acid solution of hydrogen peroxide destroys the

gela.in *in situ* with the silver image, the exposing mufb be made through the support, otherwise^bhe tanned gelatin produced with the silver image will\*float away when developed in hot water. When developed, the relief or matrix is dyed up in the appropriate colour, the dyes used being mostly acid wool dyes chosen for their colour, fastness, and rate of transfer. The dye bath must be acid to fix the dye to the gelatin, the amount of acid determining the contrast of the image nf a given matrix. The dyed and still wet reliefs are then pufc down in turn onto a mordanted blank gelatin layer, which forms the image-bearing layer of the final colour print or film. The alum mordant is necessary to assist transfer and to prevent diffusion»and loss of definitfon. This system is used for making the release prints of " *Technicolor* " cinematography. Prints have also been made from piano-graphic matricefi in which the degree of tanning varies imagewise from point to point, but the untanned gelatin is not removed by hot water. Special dyes which only stain the dhtannod parts are required for this procedure (" *Pinatype* ").

Chemical toning is also practised for colour print makingj the images being converted into coloured insoluble metallic salts, usually by way of a silver fero-cyanide image, *e.g.*, lead chromate, cadmium sulphide, vanadium ferrocyanide, mercuric iodide for the yellow; nickel dimethylglyoxime for the magenta; prussian blue for the cyan. Some form of stripping material must be used so that a final print may be assembled from the three toned silver images. Some of the above toned images are only approximations to the right colours and are apt to be opaque. Chemical treatment of a silver image to convert it into a mordant for basic dyes, which are washed out of the non-image bearing gelatin,<sup>4</sup> forms another procedure for making colour prints. Among the mordants produced in this way are cupric ferrocyanide, cuprous thiocyanate, and silver iodide. The opaque mordant can sometimes be removed after fixing the dye by treatment of the whole layer with tannic acid. Alternatively, the mordant may be made in a transparent form by choosing the conditions so that it is precipitated as a very fine-grained colloidal dispersion, *e.g.*, the iodine bleach used for converting a silver image into the iodide is compounded with a large excess of potassium iodide (B.P. 100098). The mordant processes suffer from the indifferent fastness of basic dyes and the difficulty of ensuring a constant relation between the amount of dye absorbed and the silver image. All the processes which employ separately produced part images are apt to run into difficulties of registration, due to the uneven expansion of paper and film supports. An elastic support (such as regenerated cellulose) may be deliberately introduced at one stage so that later images transferred to the final support may be accurately registered with the earlier by slight local stretching.

*Chemistry of Colour Development.*—Although coloured images can be formed by the oxidation of the developing agent alone at the site of development, this " primary " colour development has not been used in commercial processes. Agents for achieving suitable images for three

colour photography are described in a number of patents; *e.g.*, substituted naphthols, especially amino-naphthols (B.P. 498869), various aminopyrazolones (B.P. 459665; 461006). The dye is formed by condensation of a molecule of the oxidised agent with another unchanged molecule or with another of its own kind.

The technique of coupling or " secondary " colour development has been the subject of a great deal of research, its results being recorded in a mass of patent specifications (some 130 British patents alone). Many of these are concerned with properties of the system which make it more suitable for the development of coloured images in the layers of an integral tripack; *e.g.*, the attachment of special groups to the molecule of the coupler so that it becomes so large as to be fast to diffusion. The groupings proposed are many: radicals of diphenyl, stilbene, azoxybenzene, benzthiazole, certain phenols, aryl ureas, oxynaphthoic acid amide (B.P. 458400); the radicals decyl, stearyl, and oleyl (B.P. 465823); highly polymeric carboxylic acids (B.P. 479838); carbohydrate residues (B.P. 483000); polypeptide residues (B.P. 484698); sterol residues (B.P. 489093), chain molecules in which the colour-former grouping occurs several times periodically (B.P. 489161; 656768); resin residues (B.P. 489274); resinous couplers (B.P. 562675; 543290; 535341). Other patents deal with various practical aspects of the device of the protected coupler; *e.g.*, the choice of resins (B.P. 536329; 524554; 544064); the inclusion of couplers in insensitive layers adjacent to the sensitive layers (B.P. 503752; 551117).

In considering the nature of colour development, however, a similar listing of specific recommendations is impracticable, as some hundreds have been proposed in patents, most being concerned with substitutions and groups in parts of the molecule remote, from the  $r$ -active centre, such substitutions being, made in the interests of improved colour or stability of the dye. Despite the multiplicity of such proposals, the dyestuff formed has the general structure

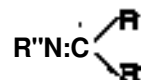

where  $\text{R}^*$  is in general &a amiso-benzene radical or derivative, derived from the developing agent, and  $\text{R}$  and  $\text{R}'$  are part of the coupler molecule and may be a ring closure. The  $-\text{N}:\text{C}=\text{}$  grouping is characteristic of these " azomethine " dyestuffs and is the chromophore in them. The dye is formed by the coupling of a reactive methylene group in the coupler with an amino group in the developer, both reactive hydrogens being oxidised off by the silver halide: \*

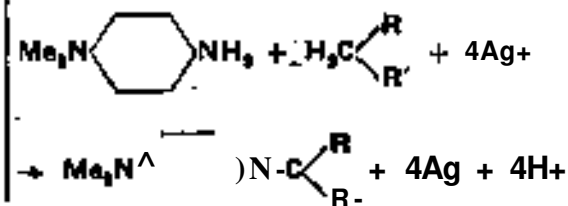

This is similar to a condensation discovered by Ehrlich and Sachs (Ber. 1899, 32, 2341), in which the unsubstituted amino group of the above equation is replaced by nitroso:

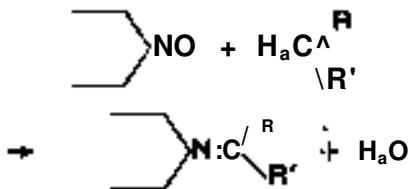

The application of these reactions to the preparation of dye images in photographic layers was first described by Fischer (B.P. 15055, 1912; 2562, 1913).

For the developer portion FT, aromatic ortho- and para-diamines are used; e.g., *p*-dimethylaminoaniline and extensively substituted analogues (e.g., 2-amino-5-diethylaminotoluene; 1-acetoacetyl-*p*-phenylenediamine). The substitution may take the form of a heterocyclic ring fused to the benzene ring, e.g.,

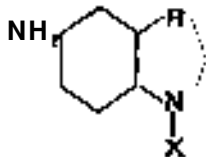

where the R—N portion of the ring can be any of a number of groups, all completely hydrogenated (U.S.P. 2196739). X may be an alkyl, hydroxy-alkyl, or allyl group, or a hydrogen atom.

For the coupler\*portion

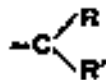

H and FV may be the adjacent carbon atoms of a benzene ring, e.g., phenolic bodies, the resulting dyestuffs of the indoaniline or indamine types being in general less stable than the azopiethine dyes formed from couplers in which the hydrogens of the methylene group are rendered reactive by linkage to R and R' through cyano, carbonyl, etc. R and R' may be atoms of a heterocyclic or 5-membered carbocyclic ring; e.g., pyrazolone, coumarone; the former being particularly valuable for the magenta colours (U.S.P. 1969479). R may be a single atom or simple group, the colour of the dye being determined by the complexity of R', e.g., R cyano; R' nitrophenyl, acetyl, benzoyl, and other complex hydrocarbons linked through carbonyl. Both R and R' may be complex groups linked by carbonyl, as in acetoacetanilide, benzoylacetone, acetacetaminophenylmorpholine. R may be as above, R' a complex heterocyclic group, as in 3-phenyl-5-acetyl-2:4-oxodiazole. Other examples and a review of the literature are given by Tull (Phot. J. 1945, d5B, 13), who also discusses the mechanism of the reaction. The baths are prepared with a small quantity of sulphite, and the coupler added just before use in alcoholic or caustic soda solution.

The dye-bleaching processes depend upon the local destruction of uniformly distributed dyes in the presence or absence of the silver\* or silver salt Knage or of a conversion product of such an image. In the most important of these processes, either a silver image is used as a catalyst for the destruction of dyes in a solution of a reducing agent, or a silver image is itself used as a reducing agent under suitable conditions supplied by a bleaching solution. Certain dyes are destroyed by hydrosulphite only in the presence of the silver (Christensen, B.P. 133034). In B.P. 395718, 397159, 397188, Gaspar describes image formation by the destruction of acid-azo and other non-leuco forming dyes by means of acid solutions of thiourea, semicarbazidj, guanidine, etc. Other reducing agents are given in B.P. 397188, 397192. These last destroy the dye *in situ* with the undeveloped silver halide, and thus give a negative image from a negative.

#### Selected Bibliography.

- L. C. Clerc, "La Technique Photographique," 3rd ed. Publications Photographiques et Cinématographiques, Paris, 1942.  
 J. M. Eder, "Ausflirliches HandbAch der Photographie," W. Knapp, Halle, 1892-1932.  
 A. Hay, "Handbuch der Photographie," J. Springer, Vienna, 1929.  
 C. E. K. Mees, "Theory of the Photographic Process," Macmillan Company, New York, 1942.

#### Section I.

- L. C. Clerc, "Structure et Propriétés des Couches Photographiques," Revue d'Optique, Paris, 1939.

#### Section II.

- W. Meidinger, "Das latente BUd," Akademische Verlagsges., Leipzig, 1943.

#### Section V.

- M. Dubois and L. Lobel, "Manuel de Sensitometrie," 2nd ed., P. Montel, Paris, 1946.  
 L. A. Jones, "Photographic Sensitometry," 1934, revised edition reprinted from J. Soc. Mot. Pict. Eng., 1931-32.

#### Section VI.

- L. C. Clerc, "Hford Manual of Process Work," 4th ed., Hford, Ltd., London, 1946.

#### Section VII.

- J. S. Friedman, "History of Color Photography," American Photographic Publishing Co., Boston, 1944.  
 W. I. Wright, "The Measurement of Colour," Adam Hilger, Ltd., London, 1944.

C. H. S. and T. H. J.  
**PHOTOSENSITISATION (v. this Vol., p. 5916).**

**PHOTOSENSITIVITY OF DYE-STUFFS.** One of the most important qualities which a dyestuff can possess is that of resistance to fading when exposed to light. However desirable its other properties may be—brilliance of shade, ease of application, fastness to washing—if it is fugitive when exposed to light its usefulness is severely limited. Many of the early synthetic dyes, especially the so-called "aniline dyes," faded very quickly, and echoes of the bad reputation they earned can'till be heard. There are now, however, ranges of synthetic dyes for almost all purposes of very high fastness indeed. This has come about mainly through the discovery of new classes of dyes, or of new variants of known classes, having inherent light fastness,

not because any deep understanding has been achieved of the fading process or its prevention. Perhaps because of the success of the empirical method of approach, scientific research on the complex subject of the photochemistry of dyes has not been pursued far. Nevertheless it is true that many of the fastest dyes are expensive, and it would be an outstanding achievement if methods could be discovered to make some of the cheaper dyes resistant to fading.

Although fading is the most obvious, it is not the only manifestation of the effect of light on dyes. The photosensitivity of dyes may be manifested by the following phenomena:

1. Fluorescence.
2. Photochromism, i.e. reversible change of shade or hue.
3. Fading i.e., permanent change in shade, generally culminating in complete destruction of the colouring matter.
4. Photosensitisation, by which the irradiated dye induces chemical changes, in its environment, e.g., in the substrate.

It is not proposed in this article to discuss fluorescence, although there may eventually be found to be a close connection between this phenomenon and that of fading. A short account of phototropy will be given, but most attention will be concentrated on fading and photosensitisation.

#### PHOTOTROPY.

Some dyes undergo a rapid change of shade when exposed to bright light on a fabric, the original shade being gradually restored when the light source is removed. This phenomenon is shown, e.g., by certain simple azo dyes derived from *p*-aminoazobenzene, especially when dyed on acetate rayon. It has led to the rejection for technical use of some otherwise desirable dyes, for clearly such dyes would give a patchy appearance to an article exposed unevenly to light.

The cause of phototropic change is not by any means understood. Superficially there would appear to be a disturbance of equilibrium conditions between two differently coloured isomers by the action of light. It was shown by G. S. Hartley that azobenzene changes on exposure to the light from its normal *trans*-form to a mixture of isomers containing a major proportion of the stereoisomeric *cis*-form, the two forms having different absorption spectra. Hydroxy- and amino-derivatives of azobenzene apparently undergo a similar transformation but the *cis*-forms of these are less stable than *cis*-azobenzene and revert so quickly to the *trans*-form that they cannot be isolated (J.G.S. 1938, 634 { see also A. H. Cook, *ibid.* 1938, 877). There is not yet, however, any evidence that the phototropic change of azo dyes on the fibre is due to this *trans*-*cis* isomerisation. The phenylhydrazones of some aromatic aldehydes, which are chemically closely related to azo dyes, have long been known to be phototropic and have been studied by several workers. Graziani showed that the phenomenon is influenced by substitution in the aromatic nucleus. Benzaldehyde-phenylhydrazone is phototropic, but chlorine in

the *o*-position in the aldehyde nucleus inhibits phototropy and in the *m*-position enhances it (Atti B. Acad. Lincei, 1913, [v], 22, i, 623). According to Stobbe, the phototropy of benzaldehydephenylhydrazone in alcohol does not occur in absence of oxygen. The same author has examined the phototropy of 4:4'-diaminostilbene-2:2'-disulphonic acid and its derivatives. The diacetyl derivative and its salts, for instance, are strongly phototropic, and again oxygen is found to accelerate the colour change (Ber. 1913, 46, 1226; see, also Annalen, 1908, 859, 37). There is evidence, therefore, that phototropy is not a purely physical phenomenon.

#### THE FADING OF DYES.

In spite of its technical importance there is no comprehensive account in any textbook of the fading of dyestuffs, or of the study which has been from time to time devoted to the subject. The published information is to be found widely scattered in a variety of journals, scientific and technical. Scientifically considered, the subject is a branch of photochemistry, and although this science, alongside that of spectroscopy, has made great advances during the past 20 years, it has not yet got beyond the stage of interpreting photochemical reactions of a very simple character, mostly those taking place in the vapour phase. On the technical side, most attention has been given to standardising the methods of evaluating the fastness to light of dyes, and to discovering by empirical methods, guided by experience, new dyes having better fastness than those already known. Study has also been made of the factors governing fading, and attempts have been made, with some success in a few cases, to discover methods of treating dyed fabrics to improve their fastness.

#### THE TECHNOLOGICAL ASSESSMENT OF THE LIGHT-FASTNESS OF DYES.

Both the manufacturer and the user of dyes need a standardised technique for determining how resistant a dye will prove to the action of light. He must be able to compare one dyestuff with another and, in addition, it is desirable to have a quantitative scale to express the fastness of a dyestuff. Experience has shown that the latter is best done by, reference to a scale of fastness represented by a range of standardised dyeings varying from the very fugitive to the very fast. Many years of careful experiment have been devoted to devising satisfactory tests and a set of standards, in England by a committee set up in 1927 under the auspices of the Society of Dyers and Colourists, which published its findings in 1934, and in Germany by an Edtheits-Kommision which was formed in 1911 and has published reports at intervals, the last in 1936. Similar work has been done in America. This work has had to take into account the many complex factors affecting the fading of dyestuffs, a thorough understanding of which is necessary if the implications of a test are to be fully appreciated.

The technologist is not concerned with the stability to light of a pure dyestuff in substance,



but with the fastness of a dyed textile fabric or, in the case of a paint or pigment, with the fastness of the pigment, which may itself be a complex of dye and substrate, in a particular medium. It is quite common for a textile dye to show very different behaviour according to the material on which it is dyed, whether this be a cellulose fibre such as cotton or linen, a protein fibre such as wool or silk, or a synthetic material such as one of the rayons or nylon. It has recently been found, for instance, that dispersed dyes on nylon are less fast than the same dyes on cellulose acetate rayon (Abbot, J. Soc. Dyers and Col. 1944, 60, 57), whilst the difference in fastness between dyeings of the same dye on wool and cotton has long been recognised. Mordant dyes will vary in fastness according to the mordanting agent used, and pigment dyes according to the substrate and the vehicle in which they are suspended. In practice sunlight or diffused daylight is generally the fading agent, and the amount of fading will be affected by the intensity of the light, by the latitude of the station where the exposures are made, and by elevation above sea-level. The humidity of the atmosphere is, for many dyestuffs, of great importance, humid conditions favouring more rapid fading. The presence of industrial gases in the atmosphere, such as sulphur dioxide, hydrogen sulphide, and oxides of nitrogen, is liable to influence fading, sometimes profoundly with certain chemical types of dye and certain substrates. Temperature, although not an important factor where simple photochemical change is concerned, may have an important influence on the complex systems under consideration, and in making exposure tests heating must be prevented. The presence of associated, non-coloured substances on a dyeing may influence fading (*see later*) and the acidity or alkalinity (pH) is an important factor. The physical condition of the substrate is another factor to be reckoned with, and in preparing samples for test the specification should describe the exact nature of the material to be used. The quantity of dyestuff on the patterns is also important, since generally a heavy shade is faster to light than a pale shade on the same substrate.

#### PRACTICAL METHODS or MAKING LIGHT TESTS.

The method of carrying out light-exposure tests depends to a considerable extent on the number of patterns involved, the facilities available, and the type of information required. Under the most favourable circumstances the patterns may, be exposed in the open to direct sunlight without protection, but this requires the keeping of a continuous watch so that the patterns may be protected if the weather deteriorates. It is the usual practice, except where information on weathering is required, to expose the patterns continuously at an angle of 45° facing south under glass and to arrange for a free circulation of air around the exposed material. Other angles and directions of exposure are sometimes preferred according to individual circumstances. In carrying out tests under glass, the rate of fading is much reduced the glass is allowed to become dirty, so that

frequent cleaning is necessary. A portion of each pattern is covered or protected from the light to serve as a comparison against the faded portion or portions. It may be desirable that a stepwise fade should be obtained for comparative purposes, and for this purpose after a suitable time of exposure a portion of the originally exposed pattern is covered with an opaque mask such as black paper, and the exposure of the remainder is continued. Where a considerable number of patterns is involved all should be covered at the same time so as to make the test comparative. In deciding when the exposures are ripe for assessment, the factor of personal judgment and the particular requirements of each, set of tests come into play and must receive consideration.

The rate of fading by exposure to sunlight will vary considerably with the latitude and the time of the year. In northern latitudes, e.g., little fading occurs between October and April except of very fugitive dyes. For many practical purposes a rapid estimation of light fastness is essential and much attention has been devoted to the development of instruments generating light equivalent in fading action to the midsummer sun and suitable for continuous operation. Although it cannot yet be said that complete success has been achieved, several instruments are now regarded as giving results of satisfactory commercial and technical value. In Great Britain the "Fugitometer" is recommended by the Society of Dyers and Colourists for accelerated fading tests, while the American Association of Textile Chemists and Colourists recommends the "Fadeometer." The relative fastness of dyestuffs using these artificial light sources is not always found to be the same as when using sunlight, no doubt because the distribution of light intensity in different parts of the spectrum is not the same.

In the early development stages there was a distinct difference between the above two instruments for, although both utilised the violet carbon arc as the light source, the only humidifying device in the Fadeometer was a shallow trough of water placed below the arc, whereas in the Fugitometer the question of humidity had been carefully studied and a really serious effort was made to obtain a fair degree of control over this factor by fitting special humidifying apparatus. As the factors affecting light fading have become more clearly understood, the two instruments have undergone continuous modification and the latest models function in a similar manner, both having the same source of light, both being fitted with temperature and humidity controls, and both having the means for rotating the test exposures round the arc.

A high intensity arc lamp in use at the British Cotton Industry Research Association laboratory for fading tests has been described by H. Hunter (*ibid.* 1940, 56, 64).

The Fugitometer (Kelvin, Bottomley, and Baird, London and Glasgow).

This machine designed by the Woollen Industries Research Association (*see ibid.* 1928, 44, 207) utilises a carbon arc lamp with a continuous burning period of 18-20 hours, the size

of the arc being approximately 1 in. The arc lamp is surrounded by a cylindrical cold water bath for cooling purposes, which feeds another shallow water bath fitted with a constant level device? electric immersion heater and thermostatic control. In conjunction with a small, variable speed, electric fan this second water bath enables the flow of humidified air over the patterns to be controlled.

The dyed patterns to be examined are placed in fifteen special containers which are suspended on the inside of the outer casing\* of the machine and revolve slowly round the arc. No glass is used in the exposure frames, which simply screen a portion of the test samples and freely expose the remainder.

The Fadeometer (Atlas Electric Devices Co., Chicago, Ill.).

This machine also employs an enclosed carbon arc lamp similar in design and principle to the Fugitometer lamp. The ventilating system uses filtered air and the temperature is controlled automatically to within  $\pm 3^\circ$  r. by means of an electric blower and dial type thermo-regulator. A water reservoir forms the base of the testing chamber and into this dip wicks stretched over wire frames of stainless steel. Water is evaporated from these wicks by the filtered air and so the exposures are conducted under controlled conditions of temperature and humidity.

The number of specimens to be tested simultaneously may be varied from 21 to 126 depending upon the size chosen. Standard holders and masks for a variety of materials are provided and are hung in the testing chamber on an annular frame which rotates round the lamp at constant speed and at a fixed distance of 10 in.

An exposure time switch provides an automatic means of shutting off the Fadeometer at any predetermined time within 24 hours and also records any interruption \*u electric service.

#### THE LIGHT FASTNESS SCALES IN USE.

By any of the above practical tests it is comparatively easy to determine whether one dyestuff is faster to light than another when applied to the same substrate, but it is much more difficult to assign quantitative values to the respective degrees of fastness which will have a significance apart from the particular test. If the quality of sunlight and the conditions of exposure were always the same it might be possible to build up a scale of light fastness related to the number of hours or days of exposure or to the quantity of sunlight falling on the specimens which is required to produce a given fading effect. In practice, however, the sunlight varies considerably in effect and its fading power is difficult to measure accurately. In addition, it is not at all easy to assess quantitatively "a given fading effect." Accelerated fading instruments were at one time considered to have advantages over sunlight for standardising exposure tests and grading light fastness according to hours of exposure; indeed, the Fadeometer-hour system is still accepted in the United States as a reference standard by trade associations and other interested bodies, but

experience of their use has brought out two important defects. First, for any given instrument the fading produced in a stated number of hours is a variable and not a constant, and, second, the fading produced in a stated number of hours varies with the instrument.

For these reasons various technical associations and societies throughout the world have given much attention during the last 30 years to the question of fixed standards of reference. In the case of textile materials the Society of Dyers and Colourists in this country is responsible for setting up standards which are generally accepted for textile purposes throughout Britain and the British Empire. The present standards consist of dyeings on wool of eight blue dyestuffs which form a graded series of light fastness to which the numerals from 1 to 8 are assigned. The 1 standard represents the most fugitive grade and the 8 standard the highest grade of light fastness. Wool is the universal choice of fibre on which to prepare standard dyeings, since humidity and other factors have less influence on the fading of dyed wool than on any other fibre.

In use, the standards are always exposed together with the materials to be tested and the fastness of each unknown sample is equated against that one of the standards which is considered to have faded to the same extent. Assessment of a number of patterns against the standards is facilitated by a graduated fade obtained by covering all exposures at suitable intervals of time.

Standards very similar to the British are accepted on the continent of Europe and in the United States of America. Eventually it is anticipated that international standards will be set up for textile materials at least. The standards mentioned have been, and still are, subject to alteration designed to effect improvement, and are not regarded by their sponsors \*u, being in any sense final; indeed, the American Association of Textile Chemists and Colorists is at present (1946) considering the setting up of a series of standard reference patterns obtained by mixing together in suitable proportions wool-slubbing dyed with a fugitive and a fast dyestuff respectively, so that a clear departure from precedent is contemplated.

To give an idea of the relation between the standards of fastness, 1-8, some German work may be quoted. The eight German standards, blue dyes on wool, show appreciable change after the following times of exposure (in "bleach hours"): 1, 3-5, 6, 18-5, 41-5, 50, 100, 138-5 hours; and the British standard\* are the same, except that the figure for No. 6 is rather higher, 69-5 instead of 50 hours (I.G. Farberind. A.-G., Textilber, 1932, 13, 539; H. Bis, *ibid.* 1937, 18, 93, 161).

Outside the textile industries there are as yet no accepted standards for coloured materials of leather, paper, and the like, although in some cases sections of these trades may make use of the textile standards. For paints and printing inks the scales in use are by no means so well characterised and defined as the textile ones, but the basic principles are the same, involving as they do the selection of graduated series of

reference samples which are exposed along with the specimens under test. One scale employed is on a 1-10 basis, where 10 represents the maximum light fastness and is obtained by the use of a madder lake; the remaining grades, however, are not associated with any particular dyestuffs, pigments, or lakes.

#### Bibliography.

In addition to references given above, the following literature may be quoted:

Factors Affecting Light Fastness.—*Textiles*, P. W. Cunliffe, *J. Soc. Dyers and Col.* 1930, 46, 108, 297; 1931, 47, 73, 225; 1932, 48, 59; R. O. Hall, *Amer. Dyestuff Rep.* 1933, 22, 437; A. C. Goodings, *ibid.* 1935, 24, 663. *Lakes and Pigments*, A. Hancock, *J. Oil Col. Chem. Assoc.* 1932, 15, 207; K. M. Richards, *ibid.* 1939, 22, 262; J. L. Deeney, *Amer. Ink-Maker*, 1933, 11, No. 2, 9, No. 3, 13; C. Koch, *Farbe u. Lack*, 1934, No. 6, 65; No. 7, 79.

Measurement of Light Fastness.—*Textiles*, H. Hunter, *J. Soc. Dyers and Col.* 1940, 56, 64; M. J. Dorcas, *Amer. Dyestuff Rep.* 1940, 29, 110; C. G. Ollinger, *ibid.* 1942, 31, 28. *Paper*, H. A. Harrison, *Paper Maker*, 1936, 91, 54; S. Pestalazzi, *Zellstoff u. Papier*, 1937, 17, 53.

Light Fastness Scales and General.—*Textiles*, Report of the Society of Dyers and Colourists on the work of its Fastness Committee, 1934, contains bibliography, published by the Society, Bradford; Report of the Fastness Committee for Dyestuffs and Textiles of the Society of German Chemists, 1939, published by Verlag Chemie, G.m.b.H. Berlin; Year Book of the American Association of Textile Chemists and Colorists, 1900-31 *et seq.*, published by Howes Publishing Co., New York; Anon., *J. Soc. Dyers and Col.* 1940, 56, 273; A. Wahl, *Rev. Gén. Mat. Col.* 1936, 40, 140; W. D. Appel, *Amer. Dyestuff Rep.* 1938, 27, 15; H. Christison, *Md.* 1944, JJ3, \*33. W. H. Cady, *ibid.* 1944, 33, 29, reviews whole subject of light fastness and gives good bibliography. *Lakes and Pigments*, S. T. Kinsman, *J. Oil Col. Chem. Assoc.* 1929, 12, 274; H. J. Stern, *ibid.* 1930, 13, 185; G. F. New, G. S. Disney and D. L. Tillcard, *ibid.* 1931, 14, 3.

#### INFLUENCE OF CHEMICAL CONSTITUTION ON FADING.

It is not possible to enunciate a set of neat rules governing the relation between fastness to light of dyestuffs and their chemical constitution, largely because the stability of any dye is so much dependent on the substrate on which it is fixed. Some broad generalisations can be made, but exceptions and qualifications are numerous. Amongst the most fugitive dyes are those of the triarylmethane series, acid dyes on wool being slightly better than basic dyes fixed on cotton with a mordant. The closely related Rhodamine dyes, as basics, are also fugitive, but some of the sulphonated dyes of this series on wool are unexpectedly fast. Dyes of the methine type, such as cyanines and Astraphloxine are poor, and sensitivity to light increases with extension of the methine chain. Amongst the azo dyes are found all degrees of light fastness. The simple

azo dye Chrysoidine, a basic dye; is very fugitive; an almost equally simple dye, Tafrazin has quite high fastness. The latter has as one component *fc* 1-methyl-3-phenyl-5-pyrazolone, and quite commonly pyrazolones give azo dyes of good fastness. Dyes made by coupling a diazo-compound with a primary amine are generally more fugitive than those having a phenol or naphthol as a coupling component (*see* Gillet and Giot, *Rev. Gén. Mat. Col.* 1923, 98). Fastness may be increased by protecting amino- and hydroxy-groups by the usual chemical methods, acylation and etherification. Direct dyes such as those from benzidine are, as a class, fugitive. Good light fastness is shown by the so-called "icejcolours," especially those obtained by coupling a diazo-compound with an arylamide of 2:3-hydroxynaphthol-4-carboxylic acid (Naphtol and Brenthol series). Amongst sulphur dyes the blacks and blues are generally fast, other shades less so, some very fugitive. Very fast acid dyes for wool are found amongst the sulphonic acids of substituted aminoanthraquinones, such as Alizarine Cyanine Green, Alizarine Irisol, and Alizarin Rubinol, to quote some of the older members of the series. The vat class contains some of the fastest known dyes. Indigo itself is very fast and so are its substituted derivatives; the thioindigo series also furnishes many very fast dyes. The vat dyes related to anthraquinone are notable for their fastness, some, such as Indanthrene Blue and Caledon Jade Green being almost indestructible on cotton. In this brief review mention must also be made of the phthalocyanines, some members of which, such as copper phthalocyanine and its halogen derivative, provide pigments unexcelled for their fastness.

In any particular dyestuff type, detailed changes of composition affect the light fastness. Introduction of halogen often has a favourable effect, for example bromination of indigo and chlorination of Indanthrene Blue, but instances are known where chlorine decreases fastness. The number and position of sulphonic acid groups affects the fastness of certain azo dyes; for instance, according to Meuly, in azo dyes from sulphonated naphthols, increasing the number of sulphonic groups decreases light fastness, and sulphanilio acid, as diazo component, gives faster dyes than metanilic acid (*Helv. Chim. Acta*, 1923, 6, 931). Numerous patents have been based on the fact that *o*-phenetidine- or *p*-anisidine-groups in triarylmethane dyes in the *o*-position to the central carbon atom, produce dyes of increased light fastness.

#### CHANGES ACCOMPANYING THE ACTION OF LIGHT ON DYES.

When a dye absorbs light the energy taken up, in the language of modern theory, raises an electron to a higher energy level, a molecule of dye thereby becoming activated. The life of an activated molecule is very short, and its excess energy is got rid of in one of several ways, as explained in the article PHOTOCHEMISTRY (this Vol., p. 526a). One of these ways is by collision with other molecules whereby chemical changes may be brought about leading to decomposition of the dye molecule. The photo-

chemical decomposition of organic substances which absorb light has been studied by many workers, and the process is often complicated and its course obscure. Sometimes many decomposition products have been identified, and it is very difficult to determine what is the primary photochemical process, the products being obviously produced by secondary reactions. The difficulty of investigating the photo-decomposition of dyestuffs is increased because the rate of decomposition is very slow and apart from exceptional cases it is difficult or impossible to isolate and identify decomposition products.

The work of different investigators is very difficult to interpret and co-ordinate because, generally, speaking, each experimenter has been interested in a particular group of dyes or a particular substrate and has directed his efforts accordingly, and it is clear that the same dye will differ in its photochemical behaviour on different substrates, in solution or in the solid form. Many experimenters have shown that moisture and air play an important part in the fading of the dyestuffs they have examined. Quantitative experiments are recorded by Hedges, who carefully compared the rate of fading of different dyestuffs on wool, cotton, and silk with the moisture content of the fabric expressed as "regain." With both wool and cotton there was a linear relationship, rate of fading increasing with water content, the dyes used on wool being some azo dyes such as Azogranine, and triarylmethane dyes such as Acid Green G and Soluble Blue; and on cotton basic triarylmethane dyes such as Magenta and Brilliant Green, and Safranin. On silk, fading fell off very rapidly at low moisture content (J. Soc. Dyers and Col. 1928, 41, 52, 341). The importance of humidity in the fading of dyestuffs on wool has been studied by Gunliffe in his work for the Fastness Committee of the Society of Dyers and Colourists (*ibid.* 1930, 46, 108).

There is abundant evidence that oxygen plays a part in the fading of many dyes, but it is by no means certain that oxidation, in some cases at least, is the primary process. Direct azo dyes on cotton and some azo dyes on wool, which fade rapidly under ordinary conditions, show little fading in evacuated glass tubes, and the same is true of magenta on a tannin-antimony mordant (Bolis, *Rev. Gén. Mat. Col.* 1908, 12, 289). Whittaker has shown that the photo-fading of cotton by vat dyes is prevented if air is excluded during exposure (J. Soc. Dyers and Col. 1933, 49, 9). Several observers have recorded the formation of substances having peroxide reactions during the irradiation of dyestuffs. Haller and Ziersch detected peroxide formation when many basic, sulphur, and ice colours on cotton were exposed to light; other classes of dyestuffs showed irregular results and no relation could be established between peroxide formation and the susceptibility of the dyes to fading (Z. angew. Chem. 1930, 43, 209; *Textilber.* 1929, 10, 951). Landolt states that hydrogen peroxide is formed when those vat dyes which cause oxidation of cellulose are exposed to light in the reduced form (*ibid.* 1929, 10, 533) and, according to Blum and Spealman, much hydrogen peroxide is formed when a dilute

aqueous solution of sodium eosin is exposed to light and air, the dye being destroyed at the same time (J. Physical Chem. 1933, 37, 1123). Some writers believe that dye peroxides are formed, just as some fluorescent hydrocarbons such as anthracene and rubrene are known to form peroxides when irradiated, but experimental evidence is lacking. Hydrogen peroxide may be a secondary product, formed during autoxidation of a first-formed reduction product, such as the leuco-compound of the dyestuff. There is good evidence that some dyes can undergo reduction by light action under suitable conditions. Thus Methylene Blue is reduced to a leuco-compound when irradiated in presence of ferrous iron; in the dark the reverse reaction occurs, the ferrous iron oxidising the leuco-compound to dyestuff (J. Weiss, *Nature*, 1935, 136, 794; 1936, 138, 80). Gillet and Giot have surmised that triarylmethane dyes do not fade by oxidation but by reduction or some form of scission (*Rev. Gen. Mat. Col.* 1923, 98) and, in this connection, a Japanese investigator, Iwamoto, states that the oxalates of Malachite Green and Crystal Violet when exposed as powder in *vitro*-glass evacuated tubes are reduced to leuco-compounds (*Bull. Chem. Soc. Japan*, 1935, 10, 420). Ackerman has recorded that aqueous solutions of triarylmethane dyes, both acid and basic, fade as well in an atmosphere of nitrogen as in air (J. Physical Chem. 1932, 36, 783), whilst Gillet and Giot state that an aqueous solution of Malachite Green will fade in the light of an arc lamp but regain its colour in daylight. There is evidently still much to be learned about these phenomena. The transformation of the cyanide of pararosaniline,



from a colourless to a deeply coloured form by ultra-violet light in alcoholic solution seems to be a clear case of ionisation by the light energy (Lifschitz, *Ber.* 1919, 52 [B], 1919f; & reaction reverses in the dark. The cyanide of Crystal Violet,  $(\text{C}_6\text{H}_4\text{NMe}_2\text{C}_6\text{H}_4)_2\text{C}\cdot\text{CN}$ , shows similar behaviour.

There are only a very few observations recorded in the literature of the isolation of definite photo-decomposition products of dyestuffs. Perhaps the most clear-cut case is the formation of isatin from indigo when the latter is exposed to daylight or a fadeometer lamp on cotton, first observed by Eva Hibbert (J. Soc. Dyers and Col. 1927, 43, 293). Later, dibromoisatin and methylisatin were also obtained from tetrabromo- and dimethyl-indigo respectively (Scholefield, Hibbert, and Patel, *ibid.* 1928, 44, 236). Isatin is, of course, an oxidation product of indigo. Recently J. Van Alphen has observed that halogenated indigos (chlorine, bromine, or iodine in the 5- and 6-positions) when exposed to light in the vat (reduced form) lose their halogen, indigo itself being formed (Bee. *trav. chim.* 1944, 63, 95). This observation recalls an earlier one by Goldstein and Gardener that the hydroquinones formed by reducing 1- and 2-halogenoanthraquinones are dehalogenated when exposed to light under alkaline conditions (J. Amer. Chem. Soc. 1934, 56, 2130). The observations suggest a test for the theory that vat dyes

undergo transient reduction when exposed to light on a fabric.

The oxalates of Crystal Violet and Malachite Green are said by Iwamoto (*I.e.*) to form respectively Michler's ketone and di-dimethylamino-benzophenone when irradiated in powder form by white light. These products might be the result of oxidation or of hydrolytic fission. In aqueous solution, according to Henriquez, ultra-violet light causes the same dyes to undergo demethylation, the conclusion being based on the colour change (Rec. trav. chim. 1933, 52, 991).

An interesting case of an azo dye has been investigated by Krollpfeiffer, Illthlhausen, and Wolf (Annalen, 1934, 508, 39). The dye stuff in question, (I), derived from diazotised sulphanic acid and phenyl- $\beta$ -naphthylamine, is fugitive, and when exposed to light either on cotton or in aqueous solution decomposes giving two products which were identified as the naphthaphenazine (II) and the triazine derivative (III). These are clearly oxidation products,

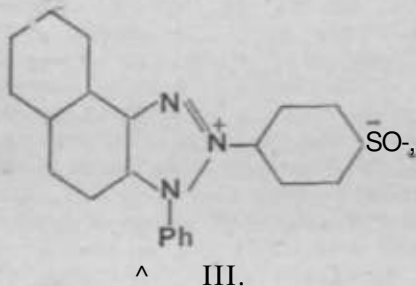
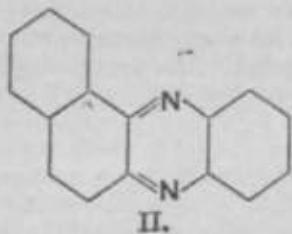
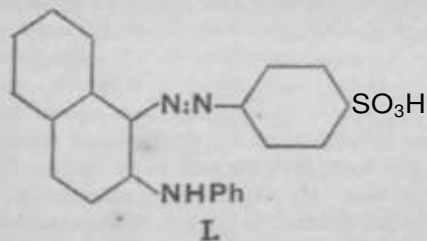

and their formation seems to be due primarily to oxidation at the —NH— group of the dyestuff. In confirmation of this, if oxygen is excluded by using an atmosphere of nitrogen, decomposition is slowed down; and benzoylation of the NH group makes the dye much faster. This dye is obviously a special case, and the observations throw little light on the mechanism of fading of azo dyes in general. Most azo dyes are too stable readily to afford identifiable decomposition products. Haller and Ziersch tried to identify decomposition products from the fading of simple azo dyes of the benzeneazo- $\beta$ -naphthylol series without success. Their experiments indicated an increase in formation of carbon dioxide when cotton dyed with the azo dye was exposed

to light; cotton itself gives carbon dioxide when exposed to light and it is not clear whether the increased amount of gas came from the dye or from accelerated oxidation of the cotton. The dyes did not fade in absence of oxygen and the authors concluded that oxidation was the primary cause of fading (Textilber, 1929, 10, 051).

#### THE PROTECTION OF DYESTUFFS AGAINST FADING.

It has already been noted that the fastness to light of members of a class of dyestuff can be modified by making detailed modification of chemical constitution, *e.g.*, by the introduction of halogen. There are, however, less drastic changes of chemical constitution which are known to bring about quite remarkable increase in light stability. The most striking instances occur among pigment and mordant dyes. When basic dyes are converted into pigments by precipitation on a suitable substrate the fastness to light of the pigment varies according to the substrate chosen. A siliceous clay known as Green Earth converts the fugitive basic dyes into reasonably fast pigments, especially Malachite Green and Brilliant Green. The increased fastness may be due to the formation of specific compounds. Phosphotungstic and phosphomolybdotungstic acid form with basic dyes insoluble pigments of remarkably high light fastness; these very bright pigments are now important articles of commerce. Why these forms of what are normally (as dyestuffs on textiles) light-sensitive compounds should be so fast is not understood. It may be due to their very low solubility in water, and to their being protected from extraneous chemical influence by a relatively large mass of inorganic material. Bancroft and Ackerman have supposed that the higher the affinity of a dyestuff is for the substrate, the higher will be its light fastness, because of its reduced chemical potential (Proc. Nat. Acad. Sci. 1932, 18, 147; J. Physical Chem. 1932, 36, 780). It is interesting to note that acid triarylmethane dyes on wool can also be increased in light fastness by treatment with a phosphotungstic acid preparation which is sold under the name "Auxanin."

Many azo dyes on cotton can have their light fastness very considerably improved by after-treatment with copper sulphate. The dyes in question contain hydroxyl groups adjacent to the azo groups, and there is no doubt that complex co-ordinated copper derivatives are formed which are more stable to light than the original dye. Some such dyes are indeed marketed in the form of their copper complexes for application to cotton. Other metals, such as cobalt and nickel, have a similar effect.

Some sulphur dyes, particularly those of yellow and brown shade which are of only moderate light fastness, are much improved by after-treatment with copper and chromium compounds. The constitution of these dyes is not known, but it seems probable that the improvement in fastness is again due to the formation of more stable metal derivatives. It is known that chrome wool dyes are generally faster to light than the unchromed dye. The

reported improvement in light fastness of Malachite Green in a tannin-antimony mordant by treatment with copper sulphate and glucose does not admit of a similar explanation, unless it can be supposed that a copper complex of tannic acid is formed (*see* Beyer, *Le Papier*, 1926, 307).

If fading is caused by oxidation it might be expected that the association of an antioxidant with a dye would prevent fading of the latter. Moureu and Dufraisse were of this opinion, and Gillet and Giot tested the hypothesis with a large number of compounds known to be antioxidants such as tannin, pyrocatechol, hydroquinone and its sulphonio acid, guaiacol, gallic acid, thiourea, using a variety of dyes. The results obtained were irregular; hydroquinone, *e.g.*, showed some protection of azo dyes on wool and cotton, but had no effect on acid or basic triarylmethane or rhodamine dyes. Thiourea protected Phlojine but not the closely related Rhodamine. It was remarked that, even when there was a protective effect, an excessive amount of antioxidant had to be used, suggesting that the whole fibre had to be protected against oxidation (*Gompt. rend.* 1923, 176, 1402, 1558, 1894; *also* *Rev. Gén. Mat. Col.* 1923, 98).

It is impossible here to give an account of the many researches which have been carried out with the object of discovering treatments to prevent fading, in the course of which a great variety of substances have been examined. Reference should, however, be made to the work of Hailer and Ziersch who investigated a large variety of dyestuffs on cotton. Whilst many substances were without effect, some accelerated fading, among which may be mentioned oxidising agents, such as nitrites, sodium perborate, and potassium dichromate, and some organic compounds such as oil of turpentine, glycerol, starch, gum tragacanth, and turkey red oil; very few substances showed protective action, the most notable being sodium metaphosphate with glucose, and thiourea. Thiourea has been found effective by a number of workers, but unfortunately it is too readily removed from a fabric to be of practical importance (Hailer and Ziersch, *Z. angew. Chem.* 1930, 43, 209; *see also* Mounier, "Tiba," 1931, 237). Thiourea and organic derivatives thereof have been patented by British Celanese for the protection of amino-anthraquinone dyes on acetylcellulose rayon against the combined action of light and an acid atmosphere (B.P. 340572; 373628; 406653), and the Society of Chemical Industry, Basle, have claimed dimethylolurea for improving the fastness to light of direct dyes on cotton (B.P. 429209). British Celanese have patented the use of many other compounds as protective agents for acetate rayon dyes, most of them being of the amine or amide type, but their value, relative or absolute, cannot be assessed from the patent claims (B.P. 243841; 340541; 355726; 361362; 361381; 378473; 406686).

#### PHOTOSENSITISATION BY DYES.

Some dyestuffs have the property of bringing about or accelerating chemical changes in systems with which they are associated, without

themselves apparently undergoing any change, when the system is exposed to light. This catalytic effect is called photosensitisation. The property is of considerable technical significance, useful in some cases, harmful in others.

The photosensitising effect finds its most useful application in photographic processes. Some classes of dyestuffs, especially those of the cyanine series, when present in very small proportion in a silver halide emulsion, induce sensitivity of the latter to light of wave-length far beyond its normal range, which is confined to the violet end of the spectrum. The induced sensitivity is towards longer wave-lengths and can be taken into the infra-red as far as 12,000 Å. with suitable dyestuffs having absorption bands in that region. The developments in photography made possible by these dyestuffs have been of the greatest importance (*see* CYANINE DYES, Vol. III, 514c). There are also dyes which have the opposite effect, one of desensitisation, on silver halide emulsions; sensitive plates bathed in a solution of such a dye can be developed in light. Basic safranin dyes were first used in this way, but many others are now known. (For an account of the theory of the photosensitisation of silver halide emulsions by dyestuffs, *see* E. J. Bowen, "Chemical Aspects of Light," Clarendon Press, 1942, p. 148.)

The photosensitising action of some vat dyes shows itself in an unfortunate way on cellulose materials. When cotton or viscose material is dyed or printed with these dyes and exposed to light, as it frequently is in the form of window curtains, for the dyes themselves are very fast to light, the material gradually deteriorates in strength and after a time becomes useless. This "tendering" effect is associated with many, but by no means all, yellow, orange or red vat dyes; homogeneous blue and green dyes do not show it. If, however, a green dyeing is obtained by mixing a blue with a sensitising yellow dye, exposure to light will not only cause tendering of the fabric but in addition destruction of the blue dye, although the latter is itself very fast to light. The deterioration of the cellulose material is undoubtedly due to oxidation to oxycellulose. The loss in tensile strength is accompanied by a rise in fluidity number in cuprammonium solution, and it has been shown by C. M. Whittaker that tendering does not take place in absence of oxygen (*J. Soc. Dyers and Col.* 1933, 49, 9).

The vat dyes which "cause tendering by light have this in common, that they are quinones, reducible to hydroquinones readily oxidisable back to the original dyestuff by air or other oxidising agent. It is, therefore, of much significance that, as Scholefield and Patel have shown (*ibid.* 1928, 44, 268), the same dyes which cause tendering of cellulose, as shown above, cause very much more rapid tendering when the cotton is exposed to the light and air with the dye in the vatted state, that is, in the hydroquinone form in an alkaline condition. Under these latter conditions, too, an accompanying blue dye [*e.g.*, tetrabromoindigo] is rapidly destroyed and, to complete the parallel, a yellow vat dye such as Caledon Yellow G which does not cause tendering in the oxidised condition, does not do so in the vatted form. The

vat dyes also sensitive the oxidation of cellulose by hydrogen peroxide and by sodium hypochlorite in the light under conditions which cause no attack in the dark (*idem, ibid.* 1929, 45, 175). Derrett-Smith and Nodder have shown that when cotton is bleached with hypochlorite, the presence of these sensitising dyes causes bad tendering if the bleaching is carried out in diffused daylight. The effect is most marked if the bleach liquor is nearly neutral; it is bad on the acid side of neutrality, but very slight at pH 11.5 (*J. Text. Inst.* 1932, 23, T293).

Landolt showed that the rate of the destructive action of the dye on the cellulose is markedly increased if the specimen is made alkaline with caustic soda before exposure to light. The rate of destruction of a blue dye is also increased by alkali, and he describes an accelerated test for the tendering properties of a vat dye, in which the dyeing on cotton is "topped" with a direct blue dye and exposed, alkaline with caustic soda, to light. The fading of the blue dye denotes tendering action as well (*Textilber.* 1933, 14, 32).

Although most attention has been concentrated on the sensitising action of vat dyes on the oxidation of cellulose, probably because the dyes themselves are fast to light, other dyes have the same effect, as was shown by Haller and Ziersch. Basic dyes on a katanol mordant, sulphur dyes and some ice colours all showed tendering, the basic dyes being especially destructive. Again the yellow dyes, Auramine G and Thioflavine T, were the worst, causing almost complete loss of strength after prolonged exposure. On the other hand, most direct colours showed some protective action against the normal tendering of undyed cotton by light (*Z. angew. Chem.* 1930, 43, 209).

E. H. R. and E. B. A.

#### PHOTOSYNTHESIS IN PLANTS.

On the ability of green plants to store up the energy of sunlight depends the whole of life upon the earth. The natural tendency of carbon to oxidise is reversed; out of carbon dioxide and water, starch, cellulose, and other organic materials are *photosynthesised* with the liberation of free oxygen. The oxygen content of the atmosphere seems to be due to the activities of plants of former ages the carbonaceous remains of which are now laid up as coal, etc. The green plant serves as food for animals, fungi, bacteria, etc., all of which, therefore, are dependent finally on the sun's radiation. These life-processes are accompanied by the reverse change, *respiration*, or the taking in of oxygen and the reliberation of carbon dioxide. The solar energy thereby runs down to heat which no longer has the power to build up endothermic compounds. This second half of the cycle fails to be complete only when organic remains are preserved as deposits by geological agents. A carbon-dioxide balance exists between its production by the respiration of living organisms, by volcanoes and springs, and by the burning of coal, oil, and wood, and its consumption by photosynthesis by green plants and by the weathering of rocks. The carbon-dioxide content of pure country air is only about 0.03 vol. %; it is indeed remarkable how so small a percentage should suffice to allow the

free growth of plants to occur. However, the total quantity of carbon dioxide in the atmosphere is about 2 million million tons, and the sea contains at least twenty-times as much.

Early workers on the relations between plants and air were handicapped by the undeveloped state of ideas of energy and of oxidation. The discoverers of oxygen were quick to investigate its connection with the growth of plants. Scheele found that green plants, like animals, produce carbon dioxide and consume oxygen, while Priestley's experiments showed the reverse change. It remained for Ingen-Housz to reconcile and explain these observations. By means of well-conceived experiments he demonstrated that plants take up carbon dioxide and liberate oxygen in sunlight, that the reverse change occurs in the dark, and that the green parts alone respond to the action of the light. Later, after the clarification of ideas of combustion by Lavoisier, Ingen-Housz was able to formulate the present-day concept of the closed-cycle relationship of carbon dioxide, light, plants, and animals. About 1800, de Saussure subjected these ideas to more quantitative chemical treatment; in particular he determined the volume ratios of carbon dioxide to oxygen both for photosynthesis and for respiration. Forty years later Liebig attempted to outline the actual course of the process of photosynthesis in terms of the equations of organic chemistry, assuming organic acids as intermediates, and this was afterwards modified by Baeyer with the assumption that formaldehyde is the first product from carbon dioxide, water, and light in the plant, followed by its polymerisation to sugars and cellulose. The end of the nineteenth century saw the first applications of physical chemistry when Blackman showed that the rate of photosynthesis was determined, according to the conditions, by the slowest of three variables, rate of light absorption (*i.e.*, light intensity), carbon-dioxide uptake or a temperature-dependent "dark" reaction the existence of which becomes evident at high values of the first two variables. At the modern period the treatment of the subject involves careful measurements on the kinetics and energetics of the process, employing such arrangements as monochromatic light, flashing lights of short duration, isotopic elements as "tracers," etc., and is aided by more precise knowledge of the coloured substances in the plant which absorb the light.

The isolation and determination of chemical structure of the green leaf pigments was accomplished by Willstätter and his school. There are two green pigments, chlorophylls *a* and *b* (*v.* Vol. III, 80a); yellow pigments, carotene, a long-chain hydrocarbon with alternate C=C—C—C bonds, and its oxidation product xanthophyll, which exist in more than one form of similar structure; the brown carotenoid fucoxanthin occurring in sea-weeds, and other pigments found in smaller quantities (*v.* Vol. II, 393(2); 398a; V, 330(Z)). The chlorophylls appear to be common to all plants and to be the only pigments capable of absorbing light energy in a form available for photosynthesis; the other pigments seem to act merely as "inner filters." Since the carotene-xanthophyll ratio in



the leaf alters during exposure to light these pigments may undergo photochemical changes or may play an essential part in the later non-photochemical stages of photosynthesis. Their effect on the photochemical part of photosynthesis, if any, is small, since their absorption is confined to the shorter waves of the spectrum. The leaf pigments are best extracted from air-dried nettle leaves (since these contain a minimum of enzymes which decompose chlorophyll) with acetone containing 20% water by volume. The acetone extract is shaken with light petroleum, into which the pigments pass, and this is washed and dried. The individual pigments may now be separated by chromatographic technique on columns of sucrose, calcium carbonate, aluminium oxide, etc., or by elaborate empirical treatment with talc, solvents, etc., as worked out by Willstätter.

Chlorophyll-a has the structure:

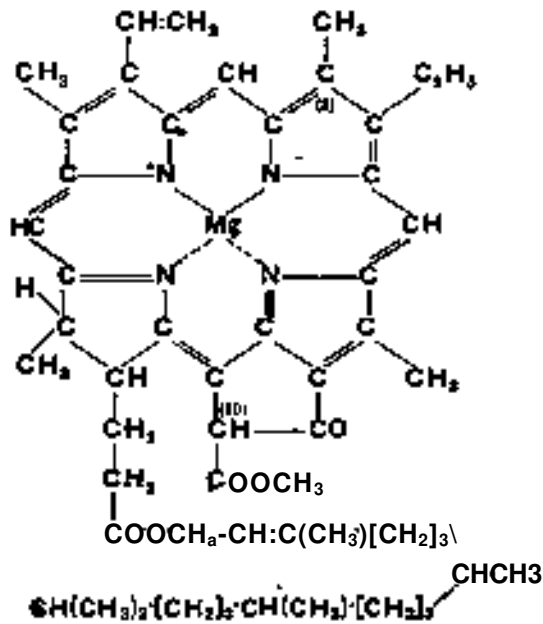

while chlorophyll-b has the group —CHO in place of the —CH<sub>3</sub> group at (3). The *a* form dissolved in ether has a strong narrow absorption band in the red at about 6,600 Å, another broader one in the blue at about 4,300 Å,<sup>3</sup> and other fainter bands in between. The *b* form in the same solvent shows a weaker red band at about 6,400 Å and a blue band at about 4,500 Å. These bands vary somewhat in position according to the solvent for solutions in organic liquids, and according as the chlorophyll is in colloidal solution in water or naturally existing in the leaf. In the plant they lie about 200 Å nearer the red than in ether solution. The true solutions, and to a lesser extent the leaf, show a red fluorescence (about 6,400-7,500 Å) when illuminated by visible or near ultra-violet light, the emission efficiency being about 10% for solutions and 0-01% for the leaf. The leaf fluorescence varies with time, increasing for the first few seconds after illumination and falling to a constant value after one minute. Chlorophyll is produced by growing plants from some colourless unknown precursor "prochlorophyll" under the influence of light. The mechanism of this

photo-reaction is unknown. Chlorophyll also appears to be decomposed by light in the plant, so that its concentration is determined by an equilibrium between its formation and disappearance.

The state of the chlorophyll in the leaf is a matter very difficult to elucidate. On the evidence of the absorption spectrum, difficulty of extraction by organic solvents, etc., it cannot be in the free molecular form. Certain results on the kinetics of photosynthesis indicate that when a light quantum is absorbed by one molecule it can assist with others in bringing about the fixation of one carbon-dioxide molecule. This has led to the concept of the "photosynthetic unit" hypothetically consisting of about 2,000 chlorophyll molecules somehow connected so that energy can pass to and fro within the unit to be available at any point to "fix" one carbon-dioxide molecule. The two most likely ways of arrangement of the chlorophyll are either an oriented colloidal form with the flat parts of the molecules piled up like coins, and held together by strong Van der Waals forces from intercalated water molecules (analogous to the colloidal form of the dye *o*-cyanine, v. Vol. III, 515a, 516c) while the tails (phytyl group) are embedded in the lipid cell material, or an oriented adsorption of the chlorophyll on the surfaces of the chloroplasts in the leaf, the chlorophyll molecules being either free to move in two dimensions over the surface or to permit of certain intermediate products moving over the surface of the adsorbed chlorophyll.

Through the microscope the chlorophyll is seen to be concentrated within minute bodies called chloroplasts which exist in the cytoplasm of the leaf cells. Different species of plants have different numbers and sizes of chloroplasts per cell, the lower forms having the smaller numbers and the larger sizes. The chloroplasts also have a colourless portion containing proteins and lipids. They possess the curious property of orienting themselves within the cells according to the light intensity, disc-like forms turning edgewise on to light of high intensity. In the case of aquatics the (dissolved) carbon dioxide reaches the chloroplasts by diffusion through the cell walls. The mechanism is different in leaves of the higher land-plants. These leaves have a very open-work or sponge-like interior arrangement of cells, exposing a very large surface, but the whole is covered in, by continuous outer layers of cells perforated only by extremely small holes called stomata, 0.0005-0.001 mm. in diameter and 50-700 in number per sq. mm., sometimes on both sides of the leaf and sometimes only on one surface. Through the stomata passes the large quantity of water vapour given off continuously by leaves (transpiration), and they are also the only channels for the carbon dioxide and the oxygen involved in respiration and photosynthesis. The apertures of the stomata are not of constant size; they close when the plant needs to conserve water and in response to other stimuli, but it has been shown that although their area when fully open is only about 2% of the total leaf area carbon dioxide can pass through them by diffusion almost as quickly as if their area equalled that of the whole leaf.

When photosynthesis is proceeding normally in a plant the ratio (vol. of CO<sub>2</sub> absorbed)/(vol. of O<sub>2</sub> evolved), (photosynthetic quotient), is almost exactly unity. Similarly the respiratory quotient (vol. O<sub>a</sub> absorbed)/(vol. CO<sub>i</sub> evolved) is also unity. The chemical equation of photosynthesis must therefore be in its simplest form:

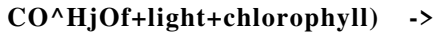

Whatever be the product  $\frac{1}{n} (CH_2O)_n$ , this reaction requires the absorption of about 112 kg.-cal. of energy. It is brought about by the absorption of visible light even at wave-lengths of 7,000 Å. In this spectral region (red) 1 "gram molecular quantum" or "einstein" is equal to 38 kg.-cal. Consequently, for the fixation of 1 mol. of carbon dioxide at least three quanta must be absorbed. This feature of the photosynthetic process is without a parallel in ordinary photochemical reactions. If all three (or more) quanta had to be absorbed by one isolated chlorophyll molecule the reaction rate should be proportional to the cube (or higher power) of the light intensity. As this is not so for photosynthesis there must be some special mechanism whereby three quanta absorbed by several different chlorophyll molecules can be brought together to effect the reduction of each carbon-dioxide molecule. Experiments have been made on the quantum efficiency of photosynthesis in monochromatic light and under optimum rate conditions.\* The best values seem to be about 0.08, and since the efficiency at 7,000 Å. cannot rise above  $\eta = 0.34$ , they represent about 20% utilisation of the light absorbed. This high value for the ultimate photochemical efficiency of photosynthesis of course is widely different from the over-all efficiency, i' Leaves are very selective in their photo-active absorption and only a small fraction of solar energy falling on a leaf brings about chemical change. When all the sun's radiation, infra-red as well as visible, received by a plant, such as wheat, is taken into account the following approximate energy distribution is found:

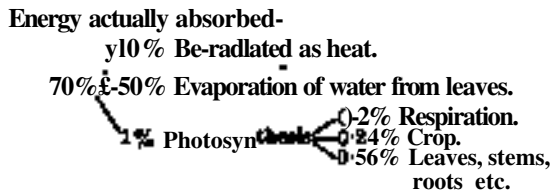

The maximum emission from the sun lies in the green region (corresponding to black-body radiation of about 5,700°o.), to which chlorophyll is largely transparent (hence its green colour). This is in marked contrast to the human eye, where the photo-active substance in the retina has been evolved with an absorption curve closely resembling the energy distribution of sunlight. Theoretically, if plants had developed a purple instead of a green-coloured substance to bring about their photosynthesis they would be capable of a much higher energy utilisation. Such a change, however, might not work under

conditions of strong sunlight as the increased light absorption might lead to local overrating of the chloroplasts followed by their destruction.

Photosynthesis of carbon compounds is brought about by any light in the visible region absorbed by the chlorophyll; as already pointed out, this means chiefly red and blue light, and these seem almost equally effective measured in terms of quantum efficiency. A plant, however, is not simply an organism dependent only on chlorophyll, light, carbon dioxide, and water. It has very complex other requirements, potassium, calcium, phosphates, and many other ions. For the production of its chlorophyll not only is magnesium needed for the actual molecule, but iron salts must be available, in the absence of which plants develop chlorosis or lack of chlorophyll. For experimental purposes the chlorophyll content of plants may be controlled and altered in this manner. Nitrates taken up by the roots and passed up to the leaves are essential for plant growth. By a photochemical process connected in some unknown way with "carbon" photosynthesis the nitrates in illuminated leaves are converted into amino-acids out of which the plant elaborates its reserves of protein and finally the protoplasm which is its very core of vitality. Though plants possess that resilience towards external changes characteristic of all living organisms, their life is a delicate balance of intricate cross-connected reactions, and any serious disturbance of the adjustment must result in breakdown. It is found, e.g., that although red light is adequate for "carbon" photosynthesis, without blue light the plant cannot assimilate the food so produced, and pines away almost as if kept in darkness. Blue light is also necessary to control the important process of transpiration or evaporation of water through the leaves. Ultra-violet light beyond 3,000 Å. is definitely injurious to any plant.

The "kinetics" of photosynthesis, or the variation of the rate with changes of the variables, light intensity, carbon-dioxide concentration, chlorophyll concentration, and temperature, are complex. Experimentally they are not easy to determine satisfactorily. Figs. 1 and 2 show the general nature of the results obtained. At high light-intensities the rate is proportional to the CO<sub>2</sub>-concentration when this is low, and becomes independent of CO<sub>2</sub> when this is large. A similar behaviour is observed when the above variables are interchanged. The effect of temperature is small either at small CO<sub>2</sub>-concentrations or at low light-intensities (lower part of Fig. 1), but when both light and CO<sub>2</sub> are high the temperature coefficient becomes large. (Above about 30°o., however, further temperature increase is harmful to the plant and destroys its vital processes.) The above kinetics are explicable in terms of three reaction stages :

1. The absorption of CO<sub>2</sub> by the plant.
2. A photochemical reaction leading to CO<sub>2</sub> "fixation."
3. A thermal reaction continuing the "fixation" process of (2) the completion of which frees the chlorophyll to engage in (2) again. ("Blackman reaction.")

At low CO<sup>2</sup>-concentration the over-all rate is controlled by reaction (1), and at low light-intensity by reaction (2); both these reactions depending very little upon the temperature. At high CO<sup>2</sup>-concentration and high light-intensity the rate is controlled by reaction (3), which has the high temperature-coefficient characteristic of thermal changes. The absolute values of

diffusion, photochemical reactions, and thermal reactions, some reversible, and some brought about by enzymes. Even the simplest hypothetical reaction-scheme consistent with this leads to a kinetic expression of such complexity as to be difficult to test adequately by experiment, and in addition it is found that more than one hypothetical scheme leads to the same kinetics. Further uncertain factors are the possible influence of light on respiration rate (since measured rates of photosynthesis must be corrected for respiration) and the existence of "induction periods," as shown by a reduced rate of oxygen evolution, at the beginning of an illumination period. The latter effect is probably due to oxygen consumption by a photo-oxidation of respiratory products which have accumulated in the dark. In addition, *hy* changes in the stomata openings, by orientation of the chloroplasts, and by changes in the total chlorophyll content, a plant reacts in a complicated way to light so that it cannot be regarded as an inanimate mechanism with a constant

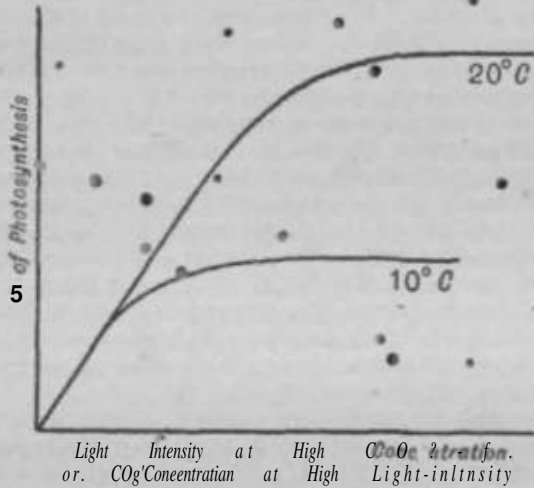

FIG. 1.

CO<sup>2</sup>-concentrations and of light-intensities in the abscissa of the diagrammatic Fig. 1 vary in different plants. Algae reach the point of independence on CO<sup>2</sup>-concentration at values not far from that normally existing in the air, but land plants can utilise much higher concentrations because of the higher resistance their leaves offer to CO<sub>2</sub>-absorption. Large CO<sub>2</sub>-

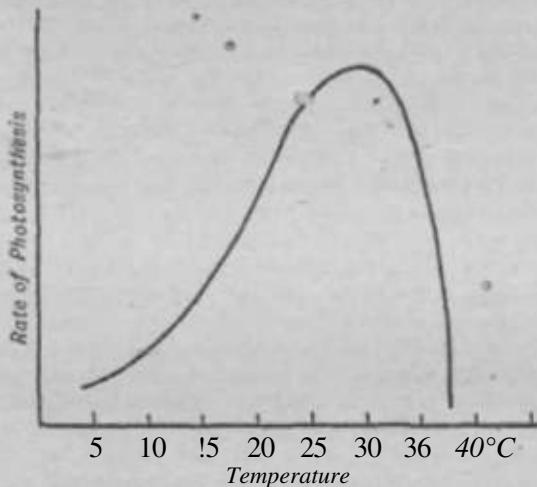

FIG. 2.

concentrations, however, reduce photosynthesis by exerting a toxic effect on the plant.

The above remarks cover the main facts of the kinetics. Many attempts have been made to obtain more refined data, and also to explain the observations by theoretical kinetic expressions derived from hypothetical mechanisms. So far this mode of treatment has proved disappointing. Only one thing is certain, that the photosynthetic process is composite, with stages depending on

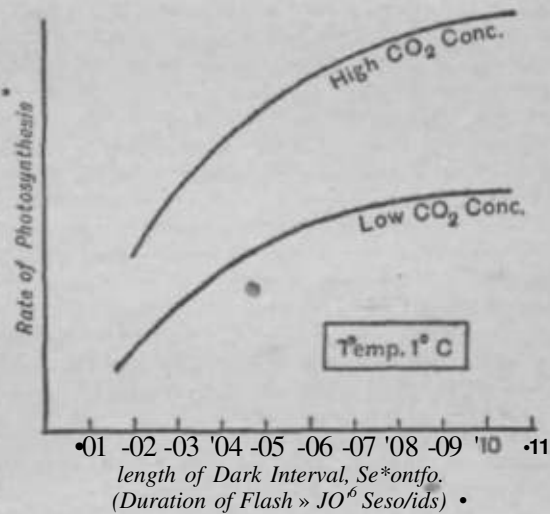

FIG. 3.

photosensitivity. Great care is necessary when experiments on the effect of any one variable are made to ensure that only the minimum change occurs in the other features of the life of the plant.

Valuable results on the photosynthetic process have been obtained by using light flashes from electric sparks of very short duration. At high light-intensities, but not at low, more photosynthesis occurs when the dark intervals between the dashes are long than when they are short. Further, the yield per flash increases at higher CO<sub>2</sub>-concentration (see Fig. 3). This shows that the CO<sub>2</sub> take-up is independent of the thermal stage called the "Blackman reaction," which affords a means of exploring the latter at different temperatures. It is found in this way that the "Blackman reaction" is essentially complete after 0.25 seconds at 1°C. and after 0.04 seconds at 24°C. The change of photosynthetic rate with intensity of very short flashes having long intermediate periods can also be shown to support the concept of the "photosynthetic unit" mentioned above. Another

variable is the duration of the flash itself. With flashes of very short duration ( $10^{-8}$  sec), at least four quanta absorbed by 2,000 mol. of chlorophyll are needed to reduce 1 mol. of  $\text{CO}_2$ , but with flashes lasting much longer, 300 or more  $\text{CO}_2$  molecules may be reduced. This is direct evidence that the "Blackman reaction" is itself composite and affords a means of further exploring it. The interpretation of the experimental kinetics in terms of hypothetical reaction-schemes is discussed below.

From what has been described above it appears certain that several intermediate stages occur in photosynthesis, and before clear ideas can be developed as to their nature the identity of the first stable chemical product needs to be known. This is as yet an unsolved problem. Liebig originally suggested that the organic acids found in plants represented the first stable resultant. However, these have now been shown to accumulate only in the dark and to arise from incomplete respiratory oxidation of sugars, and further, the "photosynthetic quotient" of unity shows that the substance sought for must have the formula  $(\text{CH}_2\text{O})_n$ . Formaldehyde, in view of its easy chemical conversion to carbohydrates, was suggested by Baeyer, and glycollic aldehyde,  $\text{CH}_2(\text{OH})\text{CHO}$ , has also been considered for similar reasons. The first directly observable photo-product in most plants is starch, a carbohydrate of very great complexity. The sugars found in most leaves result from subsequent enzymatic breakdown of the starch in the dark, although sugars are the first recognisable substances in Monocotyledons. It is chemically impossible to assume either the formation of free formaldehyde, which acts as a poison to leaves, or the direct synthesis of starch, and it seems more likely that adsorbed carbon-dioxide molecules are reduced in neighbouring sites on a surface layer so that they become linked together to split off ultimately from the surface as a glucose or similar sugar molecule.

Bates of photosynthesis are almost always measured experimentally by the determination either of the carbon dioxide taken up or of the oxygen evolved. The respiratory rate in the dark must also be measured, and in the absence of exact knowledge of the effect of light on this the measured photosynthetic rates are corrected on the assumption that respiration remains constant. Single leaves are confined in a suitable vessel, and the  $\text{CO}_2$  content of the gas surrounding it is kept constant by streaming the gas through. In the older techniques the  $\text{CO}_2$  or  $\text{O}_2$  content of the gas passing out was measured by ordinary gas-analysis. A newer method is to estimate the  $\text{CO}_2$  concentration by the amount of infra-red absorption in the region of the  $\text{CO}_2$  bands. This has the advantages of high sensitivity, convenience, and of rapid response, and permits of examination of changes of rate over much smaller time-intervals than was possible before. The gas is simply streamed through a cell of appropriate length down which passes a beam of suitably mono-chromatised infra-red-light, the beam being detected by a thermopile. The use of an infra-red spectrometer with its dispersing prism, mirrors, etc., may be avoided by employing a gas-burner as

the source of light, since the bulk of the infra-red emission is at the correct wave-length owing to the strong radiation from  $\text{CO}_2$  present in the flame. The effect of flame fluctuations is eliminated by using two cells and thermopiles, one MS standard and one to contain the gas to be measured, the thermopiles being connected back to back to a galvanometer. The use of single leaves does not permit of accurate estimations of the amount of light absorbed, owing to the large amount of light scattering. Two other techniques more adapted for this purpose employ unicellular plants. One method is to use a suspension of a species of *Chlorella*, and another to use a thin moist film of *Horridium* on a glass surface. One way of following tip photosynthesis is to surround the alga with a carbonate-bicarbonate buffer solution to maintain a constant  $\text{CO}_2$ -concentration and to estimate the oxygen evolved (with constant shaking) by a U-tube manometric method (Van Slyke's apparatus). There is evidence, however, that some species are harmed by immersion in the buffer solution, and this may be replaced by an aqueous solution of  $\text{CO}_2$  in equilibrium with a gas stream by using a dropping-mercury electrode to determine the oxygen evolved. This has the additional advantage of being very rapid in response.

Important recent work, not yet complete, has been carried out using isotopic elements as "tracers." Radio-active carbon,  $^{14}\text{C}$ , radio-active hydrogen,  $^3\text{H}$ , and heavy oxygen,  $^{18}\text{O}$ , have all been tried. The alga *Chlorella* was used as the plant. Using carbon dioxide containing radioactive carbon, and determining the distribution of radioactivity between plant and gas, several important matters came to light. Large amounts of  $\text{CO}_2$  were found to be taken up in the dark, appearing in the plant largely as  $-\text{COOH}$  groups. In light much more  $\text{CO}_2$  was taken up, and an aqueous extract of the plant yielded a water-soluble substance of molecular weight about 1,000 containing at least one alcoholic  $-\text{OH}$  and one  $-\text{COOH}$  group. This is the first chemically detectable stable product of photosynthesis, though it may be split off from the plant cell by the process of extraction. No trace of formaldehyde or other aldehydes, or of any sugar, could be detected. With radioactive hydrogen in the water used in the system the experiments were designed to see whether any hydrogen exchange occurred with the chlorophyll molecule, and so to elucidate possible reduction-oxidation changes this may undergo. The results so far have not been conclusive. Finally, by the use of heavy oxygen it has been shown that the oxygen evolved during photosynthesis comes from the water in the system and not directly from the  $\text{CO}_2$  molecules taken up. This result again emphasises that the photosynthetic process is not a simple chemical reduction but one of some complexity involving a number of stages, and also involving a "reservoir" of half-changed material awaiting further transformation when light is available.

Though many attempts have been made to represent the photosynthetic process by a series of chemical equations, it cannot be said that any degree of certainty exists in such models because

## PHTHALIC ACID.

of serious gaps in the evidence. It seems to be generally agreed that the carbon dioxide is taken up by a thermal process which is not the "Trackman reaction." Two possibilities are taken up by the chlorophyll, carbonic acid attaching itself to the Mg atom :

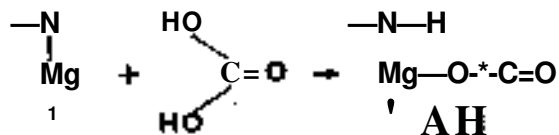

or (6) reaction with a substance RH present in the cell,  $\text{RH} + \text{CO}_2 \rightarrow \text{RCOOH}$ . The first reaction is supported by observations on the absorption of  $\text{CO}_2$  by aqueous chlorophyll solutions; the addition compound formed, however, here rapidly breaks up with elimination of magnesium from the chlorophyll molecule. The second possibility, which is more generally favoured, might be analogous to the easy  $\text{CO}_2$ -absorption of polyhydric phenols, i.e., RH might be a tannin derivative. Whether the carbon dioxide is attached originally to a chlorophyll molecule or to a cell-wall constituent, these latter 2 mol. must be closely linked themselves so that the complex may be written as:

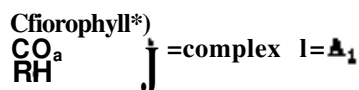

It is generally agreed that the complex  $A_x$  needs four light quanta for the photochemical part of the change, and that there are also one or two thermal stages ("Blackmail reaction"). This can be represented as:

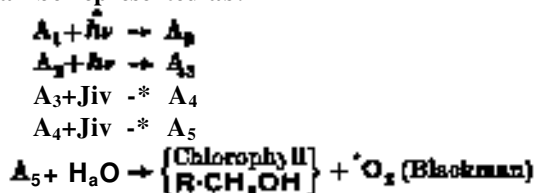

The  $\text{R-CH}_2\text{OH}$  is then assumed to be capable of adding another  $\text{CO}_2$  with repetition of the stages, so a series of  $\text{—CH}_2\text{OH}$  groups are built up together on the cell surface, ultimately to split off as a newly formed sugar molecule. >

Speculations have been directed to the nature of the photo-processes and the chemical changes, if any, undergone by the chlorophyll molecule. It has been variously suggested that the chlorophyll either enzymatically or under the influence of the light and  $\text{CO}_a$  changes from its normal form represented as GH, to GO, G, or to G H. The reactive centre of the chlorophyll molecule is thought to be position (10) (see formula, p. 593). If the four-quantum concept is correct, the change  $\text{GH}_a \rightarrow \text{GH}$  would be probably the only acceptable possibility among these. The chlorophyll molecule alternatively may be regarded as an electron reservoir, electrons being loosened by the action of light and taking part in the stages of reduction of the  $\text{CO}_a$ . It has already been explained how it is necessary to assume that light quanta absorbed on different chlorophyll molecules must come together to act on one  $\text{CO}_a$  molecule; the experimental

evidence indicating that about 2,000 chlorophyll molecules are "energetically" coupled. This aggregation of chlorophyll molecules, or "photosynthetic unit," may be "optical" in nature, i.e., act as one "conjugated" molecule so that energy absorbed at one part may freely pass to another, or may be "chemical," involving the free mobility of reactive molecules over the surface of the cell. By means of a formal set of equations it is possible to represent the latter possibility with only one type of photochemical change:

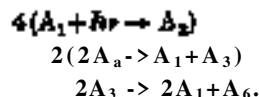

Much remains to be done, however, before the inner details of the cell-surface reactions yield up their secrets.

### Bibliography.

1. H. A. Spoehr, "Photosynthesis," Chemical Catalog Co., N.Y. U.S.A., 1926.
2. Reviews: K. Wohl, New Phytol. 1940, 39, 33; W. M. Manning, J. Physical Chem. 1938, 42, 815.
3. "Cold Spring Harbour Symposia on Quantitative Biology," 1935, 3, 71-209.
4. S. Weller and J. Franck, J. Physical Chem. 1941, 45, 1359.
5. S. Ruben *et al.*, "Isotopic tracer elements," J. Amer. Chem. Soc. 1940, 62, 3443; 1941, 63, 877.

**PHTHALIC ACID.** The three dicarboxylic acids of benzene are known as the phthalic acids. Of these the only one which has become of technical importance is o-phthalic acid, which is the compound always understood when the name "phthalic acid" is used without further qualification, the p-acid being distinguished as isophthalic acid and the p-acid as terephthalic acid.

### o-PHTHALIC ACID,

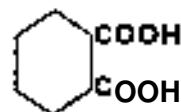

o-Phthalic acid was first obtained by Laurent in 1836 by the oxidation of naphthalene and of tetrachloronaphthalene by nitric acid. He believed it contained all the ten carbon atoms originally present in the naphthalene, but Marignao a few years later assigned to it its present formula.

Many oxidising agents have since been used for its preparation from naphthalene, substituted naphthalenes, o-xylene, phenanthrene, etc., but the most satisfactory method up to 1918 used sulphuric acid as oxidising agent in the presence of mercuric sulphate as a catalyst and was described in J.L.896 in B.P. 18221 and by Schmidt (Ber. 1904, 3^ 66).

Phthalic acid on heating forms the very stable *phthalic anhydride*,

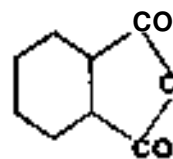

which is technically the form in which phthalic acid finds most of its applications. The sulphuric acid oxidation of naphthalene yields the anhydride as product\* and to-day the vapour phase air-oxidation of naphthalene over a catalyst also yields the anhydride and not the acid. Only the anhydride enters into considerable commercial transactions and as the two compounds are so closely related they are being considered together in the following descriptions.

*Physical properties* are shown for both phthalic acid and phthalio anhydride in Table I. The solubilities of the acid are known in many solvents and are shown in Table II, but there are few records concerning the solubility of phthalic anhydride, those published being shown in Table III.

TABLE I.

Property.	Phthalic acid.	Phthalic anhydride.
Appearance	White rhomboidal plates.	White bold needles from benzene. Appears commercially usually as flakes.
B.p.	Dehydrates to anhydride.	285°/760 mm. 204-5°/100 mm. 159720 mm.
C.p.	Variable because of anhydride formation.	1311°.
M.p.	200-230°, variable because of anhydride formation.	130-8°.
<i>p</i>	1-59319*	L527 ‡
<i>i</i> Heat of combustion ( <i>C<sub>p</sub></i> )	770*21 kg.-cal. per mol.	778-74 kg.-cal. per mol.
<i>i</i> Heat of combustion ( <i>C<sub>p</sub></i> )	770-51 kg.-cal. per mol.	779-04 kg.-cal. per mol.
<i>i</i> Heat of formation.	+ 18608 kg.-cal. per mol.	1101 kg.-cal. per mol.
2 Latent heat of fusion.	—	66B.T.U.perlb.
2 Latent heat of vaporisation.	—	157 B.T.U.
Specific heat at 20°	0-232 g.-cal. per g.	—
Heat of solution	* 4,871 g.-cal. per mol.	—
Vapour density	—	510.
3 Dissociation constants:	—	—
<i>K<sub>1</sub></i>	1-157 x10 <sup>-5</sup> /15°O. 1-141 x 10 <sup>-5</sup> /20°O. 1-123 x10 <sup>-5</sup> /25°C.	—
<i>K<sub>2</sub></i>	3-936 x10 <sup>-6</sup> /18°O. 3-937 x10 <sup>-6</sup> /20°O. 3-906 x10 <sup>-6</sup> /25°O.	—
Dipole moment at 20°.	—	5-25X10-U.

- *i* Richardson and Parks (J. Amer. Chem. Soc. 1939, 81, 3543) and Verkade and Coops (Reo. trav. chim. 1938, 47, 606).  
 † Monroe (J. Ind. Eng. Chem. 1920, 12, 969).  
 ‡ The most recent and reliable determinations by Hamer *et al.* (J. Res. Nat. Bur. Stand. 1945, 86, 881, 589).

TABLE II.—SOLUBILITIES OF PHTHALIC ACID.

Solvent.	Temperature, °C.	Solubility.		Ref.
		g. per 100 g. solution.	g. per 100 mol. solution.	
Water	0	0-36	—	1
	25	0-701	—	
	45	1-446	—	
	65	3-246	—	
	85	7-687	—	
	101-1	15-79	—	
Aqueous 10% Na <sub>2</sub> SO <sub>4</sub>	25	0-6440	—	(2)
	85 L	6-461	—	
Aqueous 15% Na <sub>2</sub> SO <sub>4</sub>	25	0-52-2	—	8
	85	5-533	—	
Aqueous 55% NaCl	25	—	0-29	11
Aqueous, saturated NaCl	25	—	0-28	
M <sup>+</sup> Cl <sup>-</sup>	25	—	0-10	
M <sup>+</sup> Cl <sub>2</sub>	25	—	0-08	
Methyl alcohol	-2	151	—	8
	19	19-5	—	
	28	21-9	—	
Ethyl alcohol, 90%	16	10-48	—	(5)
	-2	8-2	—	
	15	9-16	—	
	19	11-0	—	
	28	13-84	—	
Propyl alcohol	-3	3-42	—	(4)
	19	5-27	—	
	28	7-205	—	
Butyl alcohol	28	4-866	—	I
	28	7-860	—	
	15	0-679	—	
	28	00256	—	
	28	000263	—	
	28	0-00951	—	
	28	000852	—	
	28	00121	—	
	28	000846	—	
	28	000728	—	
Liquid SO <sub>2</sub>	—	"Mnsoluble"	—	
NH <sub>3</sub>	—	"insoluble"	—	

TABLE III.—SOLUBILITIES OF PHTHALIC ANHYDRIDE.

Solvent.	Temperature, °C.	Solubility, g. per 100 g. solution.	Ref.
Water*	0	000295	(0)
Carbon disulphide	-112-5	0013	1
	20	006	
	0	0-20	
	20	0-7	
	60	1-7	
	100	60	
	180	30-2	
Formic acid, 95%	19-8	4-46	0
Pyridine	20-25	45-5	

\* Other recorded values for water are not considered reliable because of hydration to acid.

REFEBENOES TO TABLES II AND in.

General: A. SeldeH, "Solubilities of Organic Compounds," 3rd ed., New York, 1941, pp. 570-76A.

1 Van o'r Stack Z. physikal Chem. 1902, 41, 353.  
 2 McMaster, Bender, and Well, J. Amer. Chem. Soc. 1921, 43, 1205 Ward and Cooper, J. Physical Chem. 1930, 34, 1484.

3 Herz and Hlebenthal. Z. anorg. Chem. 19f\_3, 177, 363

4 Tlmofelew, Dissertation Kharkov, 1894.  
 5 Desal and Patel, J. Indian Chem. Soc. 1935, 12, 131.

6 BourgoIn, Ann. C.Jlm. Phys. 4878, [v], 13, 406; 15, 165.

7 Aroldowd, Z. anorg. Chem. 1885, 11, 278; Etard, Ann. Chim. Phys. 1884, (vii), 2, 520; Z. 278.

8 Anshan, Chem. Abstr. 1812, 37, 1117.  
 9 Dehn, J. Amer. Chem. Soc. 1917, 39, 1401.

10 MonrBe (J. In\* Eng. Ghem. 1920, 12, 969) determined the vapour pressure of phthalic anhydride and gives the expression

$$\log_{10} p = 7.84234 - \frac{2823.5}{T}$$

where  $p$  is the vapour pressure in millimetres of mercury and  $T$  = absolute temperature.

Phthalic acid is slightly volatile in steam. Crystals of phthalic acid can be grown to great size in water; facile super-saturation is a marked feature of aqueous solutions of the acid. For the electrical conductance of phthalic acid solutions, see Jones *et al.* (Amer. Chem. J. 1910, 42, 520; 48, 187; 44, 159), Bivett and Sidgwick (J.C.S. 1910, 97, 1677), Hunt and Briscoe (J. Physical Chem. 1929, 38, 1495).

Freezing-point data for mixtures of phthalic acid and benzoic acid are given by Ward and Cooper (*ibid.* 1930, 34, 1484) and for mixtures of phthalic acid with phthalic anhydride and naphthalene by Monroe (J. Ind. Eng. Chem. 1919, 11, 1117). Similar data for mixtures of phthalic anhydride with butyl phthalate and *tert*-butyl alcohol are given by Lombaers (Bull. Soc. chim. Belg. 1924, 37, 232); with *p*-toluidine by Puschin and Zivadinovic (Bull. Soc. chim. Yugoslav. 1933, 4, No. 1, 23); and with phthalimide by Grimm, Günther, and Tittus (Z. physikal. Chem. 1931, B, 14, 169).

For the distribution of phthalic acid at 25° between water and ether, between water and xylene, and between glycerol and acetone, see Smith (J. Physical Chem. 1921, 25, 160, 204, 605, 721; 1922, 26, 256, 349), and Chandler (J. Amer. Chem. Soc. 1908, 30, 700).

For a very complete examination of the reduction of phthalic acid at the dropping mercury cathode, see Furman and Bricker (*ibid.* 1942, 64, 660). The ultra-violet light absorption spectra of anhydride and acid have been examined by Menzel (Z. physikal. Chem. 1921, 125, 161) and Goslawski and Maschlewski (Bull. Acad. Polonaise, Classe sci. math. nat. 1934, A, 45). The Raman spectrum of phthalic acid is reported by Hertz, Kahovac, and Kohlrausch (Monatsh. 1943, 74, 271).

CHEMICAL PROPERTIES.

Phthalic acid is converted by heating to phthalic anhydride, slowly at 150°c, rapidly above 180°c. The reaction is reversible and

above about 50°c. the anhydride reacts rapidly with water to yield the acid. Heating phthalic acid with excess lime gives a mixture of products including benzene and diphenyl; between 330°c. and 335°c. calcium benzoate is said to be the chief product of the reaction. The partial decarboxylation of phthalic acid to benzoic acid provides one of the principle industrial sources of the latter acid and forms the subject matter of many patents. The decarboxylation can be carried out in either the vapour or liquid phase with a variety of catalysts such as: pumice, alumina, mixtures of chromium and copper salts, zinc oxide, nickel phthalate, etc.; a temperature of about 300°c. seems necessary with most catalysts for a reasonably rapid reaction. Phthalic acid forms many stable salts both acid and neutral (*vide infra*).

Reduction with sodium amalgam and other reducing agents yields di-, tetra-, and hexahydrophthalic acids. Electrolytic reduction of the free acid in water in the presence of sulphuric acid with a lead cathode gives the 3:5-dihydrophthalic acid (Somlo, Z. Elektrochem. 1929, 85, 769). Solutions of ammonium, sodium, or potassium phthalates yield mostly phthalide,

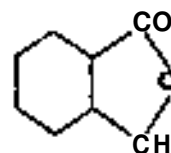

(Buhei Sakurai, Aifler. Chem. Abstr. 1932, 26, 3996; Delfino and Somlo, *ibid.* 1936, 80, 2855; Rodionov *et al.*, *ibid.* 1937, 31, 6615).

The two *ortho*-directing carboxyl groups make phthalic acid very stable to oxidising agents and resistant to the attack of most inorganic reagents; thus the acid is very resistant towards concentrated sulphuric acid merely giving the anhydride until extreme conditions are reached. Halogens do not react except under special conditions; for instance, in alkaline solutions chlorine gives a mixture of 4- and 5-chloro- and a little 4:5-dichloro-phthalic acids (Ayling, J.C.S. 1929, 253). Bromine does not react under these conditions but a high yield of the 4-bromophthalic acid results with sodium hypobromite (Wallmann, J. pr. Chem. 1930, [ii], 126, 65; see also U.S.P. 2394268). Iodine in the presence of nitric acid gives the 4-iodophthalic acid (Datta and Chatterjee, J. Amer. Chem. Soc. 1919, 41, 292).

Phthalic anhydride reacts slowly with cold water but rapidly with hot water to give the acid, and with alkalis to yield the corresponding salts. With alcohols, phthalic anhydride readily forms characteristic half esters, and this reaction has been extensively used for the characterization of alcohols and also for the resolution of optically active alcohols using alkaloid salts of the half esters. A catalyst such as sulphuric acid is usually required for producing the di-esters. Phthalic anhydride yields phthalimide with dry ammonia, phthalamic acid with alcoholic ammonia and ammonium phthalamate\* with aqueous ammonia.



Alkaline hydrogen peroxide gives monophtthalic acid,

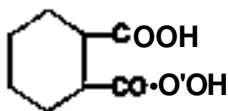

A mixture of products containing phthalide, o-toluic acid, and hexahydro-O'toluic acid is given by the catalytic hydrogenation of phthalic anhydride using a nickel catalyst at 150°. (Adkins *et al.*, *ibid.* 1933,55,1669). A full study of the reaction using many different catalysts under various conditions has been made by Austin *et al.* (*ibid.* 1937, 59, 864; U.S.P. 2114696) who showed that the highest yield of phthalide was obtained in the presence of alcohol if a nickel catalyst were used, but in the absence of alcohol in the presence of a copper chromite catalyst.

As with phthalic acid, phthalic anhydride is normally resistant to chemical attack and severe conditions have to be used to bring about sulphonation, nitration, etc. Fuming sulphuric acid at high temperatures or sulphur trioxide under pressure brings about sulphonation to give 4-sulpho-phthalic anhydride. Fuming nitric acid mixed with concentrated sulphuric acid gives 3-nitrophthalic anhydride. Nitric acid with excess boron trifluoride at 100° gives the same anhydride. Chlorine attacks the anhydride at high temperatures and in concentrated sulphuric acid to give mono-, di-, and tetra-chlorophthalic anhydrides according to conditions. Phthalic anhydride undergoes very many condensation reactions and these are listed later. In some cases one of the CO groups appears to be able to react as a keto group; thus a characteristic phthalylhydroxylamine is formed (Brady, Baker, Goldstein, and Harris, J.C.S. 1928, 533), and phthalic anhydride undergoes a modified Per'tin reaction with acetic anhydride and potassium acetate at 150-160°, to yield phthalylacetic acid (Michael and Gabriel, Ber. 1877, 10, 1554; Gabriel and Neumann, *ibid.* 1893, 16, 952):

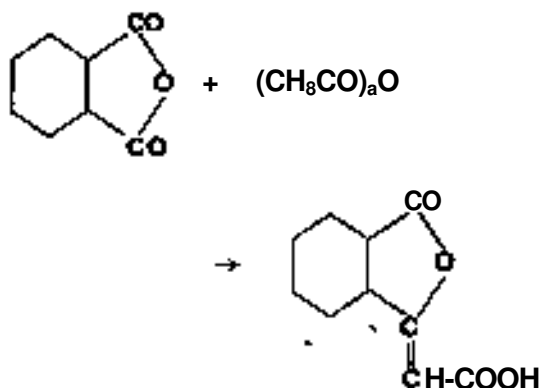

Salts.—The disodium and dipotassium salts are precipitated from aqueous solution by alcohol (hence determination of phthalic acid). The sodium phthalate is soluble to the extent of 0.06 g/100 c.c. solution in 95% alcohol at 23.5°, the potassium salt 0.0252 g/100 c.c. at 20°.

Sodium hydrogen phthalate crystallises from water as  $\text{NaHC}_8\text{H}_4\text{O}_4 \cdot \text{H}_2\text{O}$ , but, the corresponding potassium salt always occurs in the anhydrous form. Both these acid salts were early suggested for standardising volumetric alkali solutions and for preparing standard buffer solutions (Dodge, J. Ind. Eng. Chem. 1915, 7, 29; J. Amer. Chem. Soc. 1920, 42, 1655; Hendrixson, *ibid.* 1915,37, 2352; 1920,42, 725; Patten, Johnson and Mains, *ibid.* 1918, 40, 1156). Potassium hydrogen phthalate is widely used to-day for both purposes. It is best made by dissolving pure phthalic anhydride in a very slight excess of hot potassium carbonate solution, adding a little water and crystallising not below 35°. Repristallisation can be carried out from water, again not below 35°. The salt can be dried in air or in the oven, is stable and not hygroscopic (Hendrixson, *l.e.*, and Smith, *ibid.* 1931, 53, 3711).

Solubility data for potassium hydrogen phthalate in the presence of phthalic acid and dipotassium phthalate are given by Smith (*l.e.*); corresponding data for the sodium hydrogen phthalate by Smith and Strum (*ibid.* 1933, 55, 2414); for sodium phthalate and sodium carbonate by Smith and Hoegberg (*ibid.* 1941, 63, 1866); for sodium phthalate and sodium sulphate by Foote and Smith (*ibid.* 1924, 46, 84).

Clark and Lubs (J. Biol. Chem. 1916, 25, 479) introduced a set of buffer solutions using 0.1 M. potassium hydrogen phthalate solution with varying quantities of NaOH or HCl differing by values of 0.2 pH for colorimetric determination of hydrogen ion concentration. 0.05 M. potassium hydrogen phthalate solution has become accepted as a standard for pH. recent determination giving pH 4.025 at 38° and 4.010 at 25°. (Russell and Stauffer, J. Amer. Chem. Soc. 1938, 60, 2820; Hitchcock and Taylor, *ibid.*, 1938,60,2712). Hamer and Acree (J. Res. Nat. Bur. Stand. 1945, 85, 381; 1946, 36,47) made a very detailed and precise examination of the pH of potassium hydrogen phthalate solutions and give 4.005 as the value of pH of 0.05 M. potassium hydrogen phthalate solution at 25° and suggest mixtures of solutions of dipotassium phthalate and potassium hydrogen phthalate with or without KCl as standard buffer solutions between the values of 4.87 and 5.72 pH. The same authors give values for the pH of 0.05 M. potassium hydrogen phthalate solution at 5° intervals from 0° to 60°. Solutions of potassium hydrogen phthalate are opaque to ultra-violet light at and beyond 3,000 Å. and are suggested for use as ultra-violet light filters (Saunders, J. Opt. Soc. Amer. 1928, 16, 362).

Many other salts have been described. Ekeley and Banta (J. Amer. Chem. Soc. 1917, 89, 759) summarise the data on known metallic salts and describe the preparation of others. The following list of known salts is drawn largely from this paper and from later publications,  $\text{C}_8\text{H}_4\text{O}_4$  representing the divalent residue

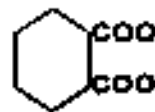

$(NH_4)_2(C_8H_4O_4)$ ;  $NH_4H(C_8H_4O_4)$ ;  
 $Li_2(C_8H_4O_4)$ ;  $Li_2(C_8H_4O_4) \cdot 3H_2O$ ;  
 $LiH(C_8H_4O_4) \cdot 2H_2O$ ;  $Nb_2(C_8H_4O_4)_4$ ;  
 $Na_2(C_8H_4O_4) \cdot 7H_2O$ ;  
 $NH_4H(C_8H_4O_4) \cdot H_2O$ ;  
 $Na_2H(C_8H_4O_4) \cdot 2H_2O$ ;  $K_2(C_8H_4O_4)$ ;  
 $is>rnuan4u4j$ ;  
 $K_2(C_8H_4O_4)(C_8H_4O_4H_1) \cdot 4H_2O$ ;  
 $RbH(C_8H_4O_4)$ ;  $CsH(C_8H_4O_4)$ ;  $Cu(C_8H_4O_4)$ ;  
 $Cu(C_8H_4O_4) \cdot H_2O$ ;  $Cu \cdot K \cdot t(C_8H_4O_4) \cdot a \cdot O$ ;  
 $Ag_2(C_8H_4O_4)$ ;  $Bi(C_8H_4O_4)_3$ ;  
 $Pb(C_8H_4O_4)$ ;  $Cs_2(C_8H_4O_4) \cdot H_2O$ ;  
 $CaH_2(C_8H_4O_4)_2$ ;  $CaH_2(C_8H_4O_4) \cdot H_2O$ ;  
 $Ba(C_8H_4O_4)$ ;  $Ba_2(C_8H_4O_4) \cdot 8H_2O$ ;  
 $BiH_2(C_8H_4O_4) \cdot H_2O$ ;  
 $Hg(C_8H_4O_4) \cdot H_2O$ ;  $Sctf>H(C_8H_4O_4) \cdot H_2O$ ;  
 $YJ(C_8H_4O_4)_3$ ;  $(C_8H_4O_4)_2$ ;  
 $CeH_3(C_8H_4O_4)_8 \cdot 3H_2O$ ;  
 $ea(C_8H_4O_4)_3 \cdot 10H_2O$ ;  $CeH_3CGgH.O)_4$ ;

$C^*(C_8H_4O_4) \cdot (C_8H_4O_4)H_2 \cdot 4H_2O$ ;  
 $Tl_2(C_8H_4O_4)$ ;  $Th(C_8H_4O_4) \cdot 5H_2O$ ;  
 $Pb(C_8H_4O_4)$ ;  
 $UO_2(C_8H_4O_4) \cdot 3H_2O$ ;  $UO_{2+}(C_8H_4O_4) \cdot 2H_2O$ ;  
 $Mn(C_8H_4O_4)$ ;  $Fe(OH)(C_8H_4O_4) \cdot 2H_2O$ ;  
 $Co(C_8H_4O_4) \cdot 2H_2O$ ;  $Ni(C_8H_4O_4) \cdot 2H_2O$ .

Titanium, lead, cadmium, barium, and zinc phthalates have all been suggested for use as pigments in paints and to reduce "chalk" (Chicago Paint and Varnish Production Club, Nat. Paint Var. Assoc. Sci. Sect. 1937, Circular No. 546, p. 251; U.S.P. 1934171; 2037322 and 3; 2244258; B.P. 455717; Gardner, Ind. Eng. Chem. 1937, 29, 640).

Disodium phthalate is put to use in several ways in the tanning industry (Jaeger, J. Amer. Leather Chem. Assoc. 1936, 81, 302) and two patents cover its use in chrome tanning (B.P. 451087; 461685).

Solubility figures for salts of phthalic acid in water are summarised in Table IV.

TABLE IV.—SOLUBILITIES OF METALLIC PHTHALATES IN WATER.

Salt.	Temperature, °.	Solubility, g. per 100 g. solution, unless otherwise stated.	Reference.
$Na_2(C_8H_4O_4)$ (solid phase $2Na_2(C_8H_4O_4) \cdot 7H_2O$ )	—	" Soluble "	
	—	" Moderately soluble "	%
	0	40*73	
	25	43-81	
	35	45-66	
	50	50-60	
$2NaH(C_8H_4O_4) \cdot H_2O$	25	About 10	
$K_2(C_8H_4O_4)$	0	60-4	
	25	74-8	
	35	78-5	
	60	78-9	
$KH(C_8H_4O_4)$	25	10-23	
	35	12-67	
	C.p.	36*12	
$Cu(C_8H_4O_4) \cdot H_2O$	—	" Sparingly soluble "	
$Cu_4K_8(C_8H_4O_4)_9 \cdot 7H_2O$	—	About 0-7	
$Ag_2(C_8H_4O_4)$	—	" Sparingly soluble "	
$Ca(C_8H_4O_4) \cdot H_2O$	—	About 0-25	
$Ba(C_8H_4O_4)$	C.p.	" Sparingly soluble "	
$Hg_2(C_8H_4O_4) \cdot 2H_2O$ ; $Hg(C_8H_4O_4) \cdot H_2O$	—	Both precipitated	
$ScO \cdot H(C_8H_4O_4) \cdot H_2O$	—	Insoluble	
$Y_2(C_8H_4O_4)_3 \cdot 3H_2O$	—	Insoluble	
$Ce(C_8H_4O_4)_3 \cdot (C_8H_4O_4)H_2 \cdot 4H_2O$	22-5	2-988 as anhydrous	
$Ce_2(C_8H_4O_4)_3 \cdot 10H_2O$	23	2-045 as anhydrous	
$Th(C_8H_4O_4)_2 \cdot 5H_2O$	—	" Moderately soluble "	
$Pb(C_8H_4O_4)$	—	" Insoluble "	
$Bi(C_8H_4O_4) \cdot H_2O$	—	" Insoluble "	
$UO_2(C_8H_4O_4) \cdot 2H_2O$	—	" Moderately soluble "	
$Co(C_8H_4O_4) \cdot 2H_2O$	—	" Sparingly soluble "	
$Mn(C_8H_4O_4)$ ; $Ni(C_8H_4O_4) \cdot 2H_2O$	—	Both precipitated	

REFERENCES.

1 McMaster, Amer. Chem. J. 1913, 49, 298.  
 2 BkeleyandBanta, J. Amer. Chem. Soc. 1917, 39, 759.  
 3 Smith and Sturm, *ibid.* 1933, 55, 2414.  
 4 Dodge, J. Ind. Eng. Chem. 1915, 7, 30.  
 5 Smith, J. Amer. Chem. Soc. 1931, 53, 3711.  
 6 Hendrixson, *ibid.* 1920, 42, 724.  
 7 Pickering, J.C.S. 1912, 101, 182.  
 • Salzer, Ber. 1897, 30, 1498.  
 9 Carius, Annalen, 1869, 148, 64.  
 jo Crookes, Chem. News, 1910, 102, 99.  
 j1 Pratt and James, J. Amer. Chem. Soc. 1911, 83, 1821.  
 12 Rimbach and Killian, Annalen, 1909, 368, 116.  
 is Vanino and Hartl, J. pr. Chem, 1906, [11], 74, 149.

**Detection.**—The interconversion of phthalic acid and anhydride is a useful aid to the detection of phthalic acid and its derivatives. The ready formation of a stable anhydride, with sharp melting-point, distinguishes phthalic acid from 180- and tere-phthalic acids. The most used, and probably most sensitive test, is the formation of fluorescein from phthalic acid or anhydride and resorcinol in the presence of a catalyst such as concentrated sulphuric acid. This has been much investigated and it would seem advisable, when testing mixtures, to carry out the test on saponified material, making use preferably of the dipotassium salt of phthalic acid, which is insoluble in absolute alcohol, for a preliminary separation (*vide infra*, "Determination,"\* and Kappelmeier, *Farben.-Ztg.* 1935, 40, 1141). The resorcinol test is very sensitive, but not completely specific, and confirmation using thymol (Toeldte, *ibid.* 1940, 45, 67) or phenol in place of resorcinol is recommended. Thus 0.05-0.1 g. of the sample, or preferably of the dipotassium salt as prepared for quantitative determination, is heated to 150-160° for 2-3 minutes with an equal weight of resorcinol and 1 drop of sulphuric acid; the cooled mass is treated with a few millilitres of dilute sodium hydroxide solution and then poured into 500 ml. water; an intense yellow green fluorescence due to fluorescein indicates the presence of phthalic acid in the sample. Use of thymol in place of resorcinol gives an intense blue, use of phenol a bright red. In place of sulphuric acid, stannic chloride has been recommended as a catalyst at a temperature of 110°.

Conversion of phthalic acid or anhydride to phthalanil is another convenient and distinctive test: 0.1 g. of the acid or anhydride is heated with about 0.5 ml. aniline for 15 minutes with gentle refluxing, 10 ml. 50% alcohol added, the solid filtered off from the cooled mixture and crystallised from boiling alcohol. Phthalanil forms white plates, m.p. 204-205°.

A convenient test for phthalic esters is provided by the production of the N-benzylamide of phthalic acid direct from the ester by refluxing a mixture of 1 g. ester, 3 ml. benzylamine and 0.1 g. ammonium chloride. The amide is crystallised from aqueous acetone and alcohol and melts at 178-179° (Dermer and King, *J. Org. Chem.* 1943, 88, 168).

Other derivatives suitable for identification of phthalic acid are the diphenacyl ester, m.p. 154-4°; the di-p-bromophenacyl ester, m.p. 152-8°; the di-#-phenylphenacyl ester, m.p. 167-5°; the di-p-nitrobenzyl ester, m.p. 155-5°; the acid benzyl ester, m.p. 106-107°; the S-benzylthiuronium salt, m.p. 151°; the p-bromobenzylpaewfothiuronium salt, m.p. 166° (Kelly and Kleff, *J. Amer. Chem. Soc.* 1932, 54, 4444; Drake and Sweeney, *ibid.* 1932, 54, 2059; Donleavy, *ibid.* 1936, 5t, 1004; *ibid.* 1941, 63, 3526; Lyman and Reid, *ibid.* 1917, 89, 701).

#### Determination of Phthalic Acid, Anhydride and Derivatives.

Phthalic acid, or anhydride after hydrolysis, can be titrated conventionally against standard alkali, although it has been recommended to use

indicator solution (commonly phenolphthalein) made up in non-alcoholic solvents. Crude phthalic anhydride can be analysed by sublimation, of a sample at 200-220° into a plug of cotton which is then extracted with a known volume of boiling N/10 NaOH, the excess of which is titrated against standard acid solution (Boswell, *ibid.* 1907, 29, 235; Downs and Stupp, *J. Ind. Eng. Chem.* 1918, 10, 596). Phthalic anhydride in the presence of phthalic acid can be determined by firstly titrating against N/2 sodium methoxide solution in methanol using dioxan or acetone as a solvent and then titrating a second sample in pyridine against N/2 NaOH solution. The two reactions involved are:

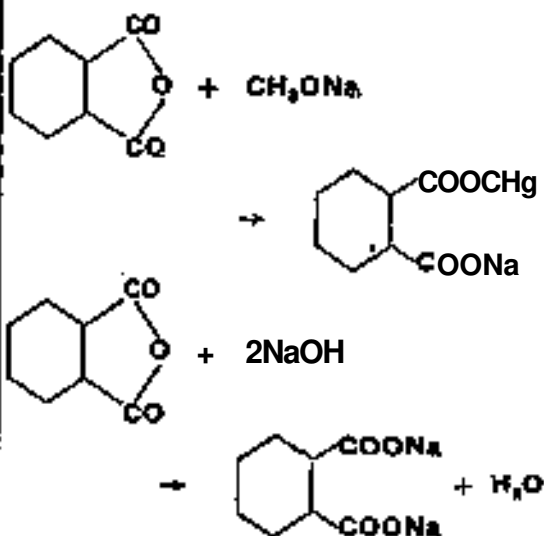

and the difference in the titre of the two samples is equivalent to the anhydride present whatever free acid is contained in the sample (Smith and Bryant, *T. Amer. Chem. Soc.* 1936, 58, 2453). Mixtures of acid and anhydride can also be analysed by use of the Karl Fischer reagent, by complete hydrolysis of the anhydride either in the presence of a boron trifluoride catalyst, or in pyridine with sodium iodide as catalyst, followed by titration of the excess water with Karl Fischer reagent (Smith, Bryant, and Mitchell, *ibid.* 1940, 62, 608; 1941, 68, 1700).

The determination of phthalic acid and derivatives in various products (*e.g.* phthalates in denatured alcohols, in plastics, etc.) has been the subject of much investigation, but the most satisfactory techniques evolved depend upon either the isolation of the sparingly soluble lead phthalate or the precipitation in alcoholic solution of potassium phthalate.

Schrader and Wolter (*Ges. Abh. Kennt. Kohle*, 1921, 6, 79) suggested the use of the relatively insoluble lead phthalate in dilute acetic acid as a means of separation of phthalic acid from benzoic acid; Fonrobert and Munchmeyer, (*Farben-Ztg.* 1936, 41, 747) and Bruckel (Farbe u. Lack, 1936, 451) determined phthalates in varnishes, and Thames (*Ind. Eng. Chem. [Anal.]*, 1936, 8, 418) in cellulose nitrate and plasticisers by precipitation of lead phthalate with lead acetate and conversion of this precipitate into lead sulphate. The inadvisability of weighing

the precipitated lead phthalate and hence deducing the phthalic acid present is shown by the work of Smith and Stremper (*ibid.* 19 A, 16, 416).

The use of the insolubility of dipotassium phthalate in absolute alcohol was suggested for the detection of phthalic esters in essential oils by Bennett and Garratt (*Perf. & Essent. Oil Bee.* 1923, 14, 359) and applied for determination purposes in perfumery products by Hanay and Hoyt (*J. Amer. Pharm. Assoc.* 1926, 15, 454) and Walbaum and Bosenthal (*J. Schimmel*, 1929, 195). Naves and Sabetay (*Perf. & Essent. Oil Rec.* 1938, 29, 22) review this method and suggest for the determination of phthalic esters in essential oil and perfumery products, the following procedure: 1-2 g. of the sample is refluxed for 1 hr. with 25 ml. N/2 sodium hydroxide in absolute alcohol, then cooled in ice and filtered through a sintered glass filter. The precipitate is washed with 30-50 ml. ice-cold absolute alcohol, a mixture of 5 ml. absolute alcohol and 10 ml. dry ether, and dried at 140° to give anhydrous  $C_8H_4O_4K_2$ . The weight found multiplied by the factor 0.917 gives the weight of ethyl phthalate in the sample.

The dipotassium salt method has been adapted by Kappeneier (*Farben-Ztg.* 1935, 40, 1141; 1936, 41, 161; 1937, 42, 561) to the determination of phthalic anhydride in alkyd resins, and materials containing these resins, and is the most widely used method to-day for this purpose. As detailed in A.S.T.M. Standards, 1944, Pt. II, p. 1511 (Designation D. 563-43) for the determination of phthalic anhydride in alkyd resin solutions, the method is as follows: A quantity of the liquid, equivalent to 2-g. solid content is weighed into a 500 ml. flask fitted by means of a ground glass joint with an air reflux condenser 32 in. in length; 10 ml. benzene are added and the mixture warmed until homogeneous when 150 ml. of 0.5 N. KOH in absolute alcohol are added. After warming at 60° for 1 hour the mixture is refluxed gently for 3 hours, cooled, allowed to stand 1 hour and the sides of the flask washed down with 50 ml. absolute ether. The precipitate is filtered off on a Gooch containing an asbestos mat, and washed with 50 ml. of a mixture of equal parts of absolute alcohol and ether, using five 10 ml. portions and not allowing air to suck through the crystals because of their hygroscopic nature. The solid is dried for 1 hour at 60° and then to constant weight over sulphuric acid in an evacuated desiccator. One g. of the precipitate,  $C_8H_4O_4K_2 \cdot C_2H_5OH$ , is equivalent to 0.5139 g. of phthalic anhydride. Goldberg (*Ind. Eng. Chem. [Anal.]*, 1944, 16, 198) has suggested several modifications, including drying at 150° for 3-4 hours to give quantitative loss of alcohol to  $C_8H_4O_4K_2$  and saponifying the original sample by warming 4-5 hours with 0.5 N. alcoholic KOH at 55°. He also suggests a volumetric procedure to estimate the dipotassium salt, utilizing 0.1 N. perchloric acid in glacial acetic acid in the presence of acetic anhydride with, preferably, Methyl Violet as indicator. The method is reliable for simple alkyd resins but for the determination of phthalic anhydride in products containing tall oil,

naphthenates, and dibasic acids such as maleic some modifications are necessary (Philipp and Scholz, *Farben-Ztg.* 1942, 47, 87; Kappeneier and Van Goor, *Verfkroniek*, 1943, 16, 8, 17). A revised Kappeneier method is described by Eickhoff, Kebrich, and Wills (*Ind. Eng. Chem.* 1945, 37, 399) for determining phthalate content of pigments separated from red lead paints but no reliable method was found for determining the phthalate content of the extracted vehicle.

A third method for determining phthalic anhydride content of alkyd resins has been described by Kavanagh (*Ind. Eng. Chem. [Anal.]*, 1936, 8, 397) and is based upon the fact that careful acidification of the saponified resin allows the freeing of fatty acids without liberating any phthalic acid; the fatty acid is removed by ether extraction and the phthalic acid set free by further acidification.

TECHNICAL MANUFACTURE.

Two processes only have become important for the industrial production of phthalic anhydride. The earlier method discovered in the late part of the nineteenth century involved the oxidation of naphthalene in the liquid phase by concentrated sulphuric acid in the presence of mercuric sulphate or other metallic salts as a catalyst. Biedig and Brown (*Z. physikal. Chem.* 1903, 46, 502) showed that the velocity constant for this oxidation of naphthalene with sulphuric acid at 275° was increased five-fold by the addition of 1% mercuric sulphate.

The original patents (G.P. 91202; B.P. 18221, 1896) described how 100 Jtg. naphthalene, 1,500 kg. sulphuric acid monohydrate, 50 kg. mercuric sulphate, were heated gradually from 200° to above 300° so that the phthalic anhydride finally all distilled out from the iron retort leaving mercuric sulphate, behind, suitable for re-use. Semi-continuous production was achieved by feeding portions of a mixture of sulphuric acid and naphthalene into a still containing more sulphuric acid and mercuric sulphate, distilling over the phthalic anhydride formed until a residue was left and then repeating the procedure. In all cases the crude phthalic anhydride had to be separated from sulphuric acid in the distillate and was purified by washing and sublimation. The strength of acid used varied and Wibaut (*Ingenieur Chimiste*, 1926, 10, 177) in a review and description of some investigation into the process, claims that the best yields were obtained with 20% oleum in amount equal to twelve times the weight of naphthalene and used at a temperature of 285-295°. A mixture of mercuric and copper sulphate is said to be preferable to mercuric sulphate alone. Various other metallic salts have been suggested as catalysts for this process but there is little evidence of their industrial use. Until the end of the First World War, this process provided the only commercial source of phthalic anhydride, but during the war-years a modern vapour-phase oxidation of naphthalene with air over a vanadium pentoxide catalyst was discovered almost simultaneously in Germany by Wohl and in America by Conover

and Gibbs. Walter (J. pr. Ghem. 1895, [ii], 5, 107) had demonstrated the use of vanadium pentoxide as a catalyst at 600°o. for the oxidation with air of aromatic hydrocarbons such as toluene. In 1916 Wohl filed G.P. 379822 claiming the use of vanadium pentoxide between 300° and 580°c, whereas a year later Gibbs and Conover applied for U.S.P. 1285117 claiming the same type of catalyst between 350° and 550°o.

Since these early years of the process many patents have been filed describing types of catalyst, construction of plant, operating procedure, and methods of purification. It is difficult to assess the value of each patent especially as the individual manufacturers of phthalic anhydride disclose little about the details of their processes and because there has been but little fundamental work on the reaction. Apart from the many patents which are listed below on various aspects of the process the following papers contribute considerable information, especially that of Conover and Gibbs concerning the early American work on the reaction, and those of Marisic and of Brown and Frazer on the mechanism of the reaction: C. Conover and H. D. Gibbs, J. Ind. Eng. Chem. 1922, 14, 120; M. M. Marisic, J. Amer. Chem. Soc. 1940, 62, 2312; H. T. Brown and J. C. W. Frazer, *ibid.* 1942, 64, 2917; R. N. Shreve and R. W. Welborn, Ind. Eng. Chem. 1943, 85, 279.

o-Xylene has recently been used as a raw material in place of naphthalene in one large plant in the U.S.A.; the catalyst and converters used are apparently very similar to those of the more conventional naphthalene-consuming plant. A very full description of this interesting development is given in Chem. Eng. 1946, 53, No. 8, 116, 138.

### Catalysts.

Besides vanadium pentoxide many other catalysts have been suggested, but it is fairly certain that to-day little use is made of any of these, other suggestions. Conover and Gibbs tried out many metallic oxides but claimed that vanadium pentoxide was the preferable one, molybdenum oxide being the next best; yields of phthalic anhydride were 82 and 58% respectively. References to catalysts other than vanadium pentoxide are: alumina (U.S.P. 1374722; 1930716); ferric oxide with iron pentacarbonyl (U.S.P. 2270779)<sup>1</sup>, vanadyl chloride (B.P. 164785); tin or bismuth vanadate (B.P. about 228771).

The early vanadium pentoxide catalysts were either lump or, powdered oxide alone, or oxide supported on pumice. It is certain that all commercial catalysts to-day are of the supported type, but the patent literature is so full of variations that it is not easy to give full details of these. The modern tubular converter (*vide infra*) has made the use of a pelleted or granular form of catalyst essential, and moreover the pellets must be capable of remaining at about 400°o. for a long time without powdering. Many supporting materials for the vanadium pentoxide have been suggested and many promoters patented. Shreve and Welborn decided that the most successful catalyst of the many I

tried was that obtained by decomposing ammonium metavanadate by heating\* and fusing the resulting oxide on a commercial silica gel of 8-10 mesh until the carrier\* was coated with a dull purplish red oxide. The literature is unanimous in agreeing that fused oxide is preferable to a precipitated material.

The performance of individual catalysts is very often difficult to ascertain from the literature and even in some of the academic contributions the yield of phthalic anhydride is estimated simply by alkyrimetric titration, ignoring the substantial and variable amount of maleic anhydride present.

A list of patents concerning the use of vanadium pentoxide and of supporting material\*, for the oxide follows:

Patent.	Claims and Comments.
B.P. 110518 U.S.P. 1285117	The original Gibbs patent claiming vanadium pentoxide active 350°-650°o.
B.P. 145071 G. P. 379822	The original Wohl patent claiming vanadium pentoxide active between 300° and 550°o. Pumice described as carrier.
G.P. 168291	The early patent (1904) of Walter claiming vanadium pentoxide as a catalyst at above 500°o.
F.P. 635717	Vanadium pentoxide* and pyrovanadates.
B.P. 170022	Vanadium pentoxide heated above 500°O. claimed as an oxidation catalyst for many reactions.
u.S.P. 1489741	Vanadium pentoxide mixed with other oxides of vanadium or molybdenum. Presence of sodium, copper, lead, cobalt, aluminum, and cadmium oxides said to decrease phthalic anhydride yield and to increase production of maleic anhydride.
U.S.P. 2294130	Phosphate incorporated to reduce by-product formation and to diminish rfolence of reaction.
U.S.P. 2157965	Vanadium pentoxide activated with titanium or zirconium, on pumice as a carrier.
U.S.P. 1938776	Vanadium pentoxide activated with silicon or zirconium carbide.

### Mechanism.

The fundamental mechanism of this reaction is probably complex and has not yet been worked out. Besides phthalic anhydride there is always present in the reaction product up to 5% of maleic anhydride, smaller quantities of 1:4-naphthaquinone, benzoic acid, and probably other impurities. In addition to carbon dioxide and water, carbon monoxide is always found in the gaseous products. No fully satisfactory mechanism has yet been substantiated to explain the formation of all these products. That the main reaction is a step-wise oxidation through the 1:4-quinone or corresponding hydroxyl compound has received considerable support in the past but with little factual evidence. It is made unlikely by the demonstration of Brown and Frazer that this quinone itself gives a very low yield of phthalic anhydride when oxidised. The presence of any other quinone or hydroxyl compounds has not been satisfactorily shown. The production of the

maleic anhydride can be conjectured as arising from oxidation of the 1:4-quinone, from the further oxidation of phthalic anhydride or from the further oxidation of benzoic acid. Again there is no proof as to which route is actually followed, but further oxidation of phthalic anhydride would seem the most likely. It is known that phthalic anhydride yields some maleic anhydride under the conditions necessary for naphthalene oxidation. The formation of benzoic acid would seem to be most satisfactorily explained by the partial decarboxylation of phthalic acid at the high temperatures of the reaction. From what stage in the process the carbon monoxide originates is unknown but BroVn and Frazer conclude from their quantitative results that this gas is made in considerable quantity at some time during the process and that part of the carbon dioxide comes from oxidation of the monoxide.

A. O. Jaeger (J. Amer. Leather Chem. Assoc. 1936, 31, 302) mentions that carbon suboxide,  $C_3O_2$ , is also present in the reaction gases and writes equations showing its production with maleic anhydride from the oxidation of phthalic anhydride or from benzoic acid, but there is no supporting evidence. However naphthalene is oxidised, very considerable quantities of heat are generated, the figures being for the most significant overall reactions:

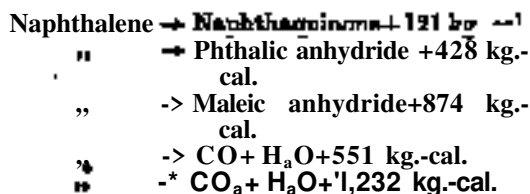

Thus it will be seen that the removal of heat from the reaction zone will be a very critical factor in the successful performance of the operation. The actual way in which the catalyst itself brings about the reaction is not known but quite early it was established that the pentoxide became reduced to lower oxides; Weiss, Downs, and Burns (Ind. Eng. Chem. 1923, 15, 965) reported that the extent of the reaction was not dependent on the ratio of  $V_2O_5$  to  $V_2O_4$ . More recently Pongratz and Scholtis (Ber., 1943, 76 [B], 117) showed by both X-ray diffraction and chemical analysis this same production of lower oxide.

Process and Plant.

Essentially the process is a simple one, but the means of bringing it about economically have been developed very largely since the early days. This is made apparent by the large number of patents covering types of apparatus and methods of procedure. Unfortunately there has been no reliable description of the plant as a whole except in the recently published reports of investigating teams sent to examine German chemical industry.

Four of these reports, C.I.O.S. File No. XXVII—80, XXVII—85, and XXVIII—29, and B.I.O.S. Final Report No. 753, describe in some detail the phthalic anhydride plants at Uerdingen, Ludwigshafen, and Schkopau. Al-

though the German procedure and plant is probably not identical with American and British equivalents the differences are likely to be only in detail and the following account is based largely on these four reports.

Naphthalene of hot pressed quality (c.p.  $\approx 78^\circ C$ ) was filtered at  $120-130^\circ C$  and fed via a rotameter to a carburettor shown diagrammatically in Fig. 1. In this carburettor the hot naphthalene descended a stepped spiral together with hot air passing in the same direction; all the naphthalene was evaporated before reaching the bottom of the spiral and the mixed vapours then passed upwards through a pipe threading the centre of the spiral. The air was fed from a rotary compressor working at about 7 lb. per sq. in. gauge pressure, via a tubular heat-exchanger through which the hot reaction-gases after oxidation also passed. The air passing to the carburettor was thus heated to  $160^\circ C$ . The proportion of naphthalene in the air mixture was 0.63 molar per cent., well below the explosive limit of such a mixture. About 244-286 lb. per hour of naphthalene were fed to the catalyst. The reaction vessel (or converter) containing the catalyst was similar to a tubular heat-exchanger but contained a hollow central core. The vessel is shown diagrammatically in Fig. 2. It contained nearly 3,000 vertical tubes, 25 mm. internal diameter, 3.0 m. long, filled with catalyst pellets about 5 mm. diameter by 5 mm. long. The tubes were surrounded with molten potassium nitrate-sodium nitrite mixture which was circulated upwards through the central core and downwards round the tubes by a submerged pump. Tubular air coolers carrying cooling air from a subsidiary blower were immersed in the salt mixture to remove the surplus heat of reaction. The temperature of the catalyst, measured by eleven thermocouples arranged to slide into the tubes, was kept at  $350^\circ C$  for a new catalyst or up to about  $400^\circ C$  for an aged catalyst by manual control of the cooling air. No great precision in controlling the ratio of naphthalene to air was attempted.

From the bottom of the converter the mixture of oxidation products at nearly  $400^\circ C$  passed to the afore-mentioned heat exchanger and thence to the condensing system, which consisted of 16 mild steel rectangular vessels 20 ft. long, 15 ft. high, and 2 ft. 6 in. wide, all arranged in series. The gases enter one end of each vessel, pass through to the bottom, round a central baffle and then upwards to the exhaust. The first two or four were water cooled, the remainder lost their heat to atmosphere only. Solid phthalic anhydride was removed from each condenser by a screw conveyor which emptied into a bucket-conveyor feeding melt-kettles. The gas issuing from the last condenser was at about  $40^\circ C$  and was exhausted from the system by fan direct to atmosphere. The crude phthalic anhydride was charged in 17 ton batches to steel melt-kettles together with 12-60 lb. of 98% sulphuric acid. The mixture was heated to about  $200^\circ C$  for several hours, then neutralised with chalk and charged directly to a batch steel still of 5,000 gal. capacity, heated by a coil welded to the outside surface and carrying steam at  $300^\circ C$ . A short column filled with Raschig

PHTHALIC ACID.

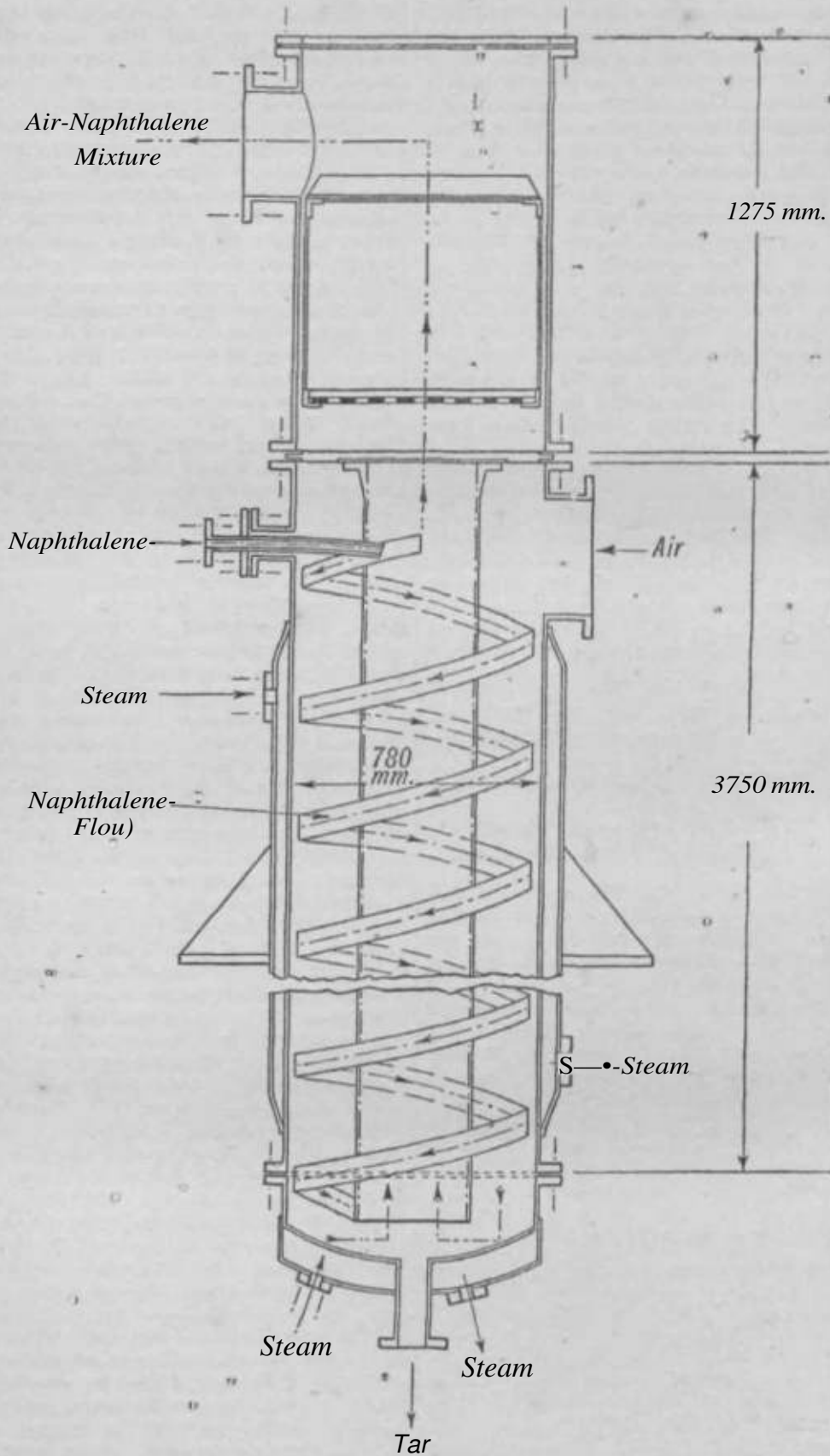

FIG. 1.

rings was fitted to the still and the phthalic anhydride was distilled with a slight but unmeasured reflux and at 30 mm. mercury pressure. The phthalic anhydride vapour was condensed in a condenser using an ethylene glycol-water mixture boiling just above the melting-point of the anhydride. Some residue was left in the still but the whole of the distillate was



fed to a drum flaker as pure phthalic anhydride. When about 9,000 lb. of residue had collected from several distillations these were charged to a second still fitted with a powerful stirrer and heated (similarly to the refining still. This charge was then distilled to dryness, the distillate losing fed back into the crude anhydride, the residue being discharged mechanically by the stirrer through a side manhole in the still. The yield of refined phthalic anhydride was about 81% of theory.

The monthly production of a single unit was from 76-100 tons. The total cost of the Uerdingen plant of capacity 300-400 tons per month is given as 4\*5.5 million Reichmarks.

Various types of converters are described in U.S.P. 1599228; 1909358; 1936610; 1946353; 1945812; 1969898; 2117359; 2142678; B.P. 283887; 534743. Various heat-exchange liquids for use in the converters have been patented: Mercury in U.S.P. 1873876; mercury alloys with cadmium in U.S.P. 1689860; with lead and

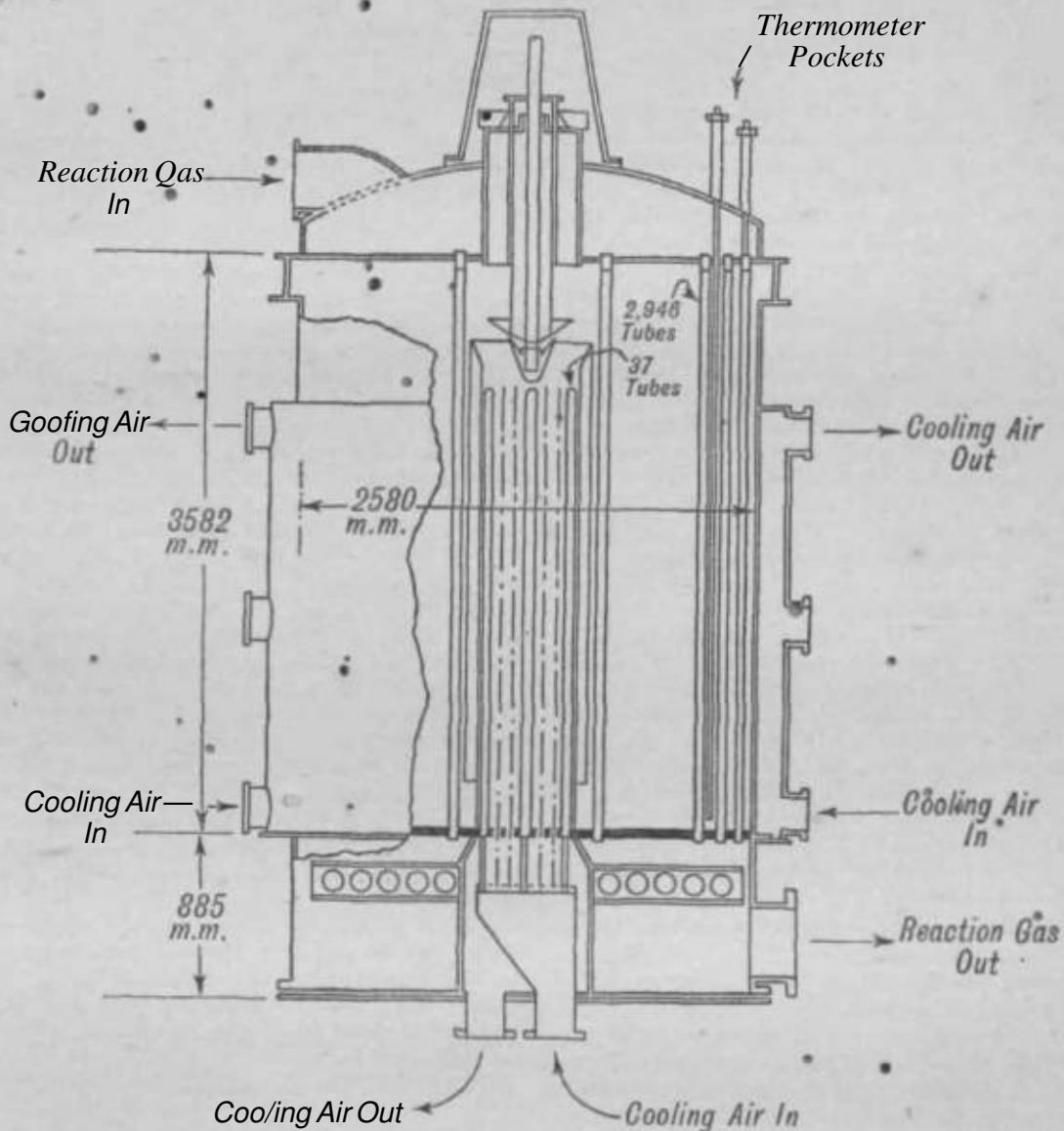

Fig. 2.

tin in U.S.P. 1735951; and with lead in U.S.P. 1834679; see also B.P. 282559; mixtures of sodium and potassium nitrates in B.P. 276321 and mixtures of sodium nitrate and nitrite in U.S.P. 1936610 and 1945812.

Removal of heat of reaction by means other than through a heat-exchange medium have been patented as follows: Use of excess air, U.S.P. 2071361; injection of water spray into catalyst zones, B.P. 249973; admixture with the air of an inert material such as carbon tetrachloride, B.P. 355192.

Quite recently the problem of heat removal has been overcome by the use of "fluid catalysts" of a type similar to those developed in the cracking industry. A vanadium pent oxide catalyst is used as a fine powder and is carried through from the reaction zone into a cooling zone, separated from the gaseous reaction products and reintroduced into the reaction zone; a plant working on these lines is described by J. A. Lee (Chem. Met. Eng. 1945, 62, -No. 7, 100). Patents covering this method are B.P. 568913, 1941, and U.S.P. 2373008, 1945, but it is

interesting to note that W. A. Caspari as early as 1928 described in U.S.P. 1674589 the use of vanadium pentoxide in a finely divided condition and suspended in the gaseous reactants for the preparation of phthalic anhydride.

Methods of recovery of solid phthalic anhydride from the gaseous reaction mixtures are summarised as follows: Use of various types of surface condensers, U.S.P. 2219916; 2219333; 2247910; 2067019; 2004586; 2112024; 2076033. Scrubbing with an inert water-immiscible solvent, B.P. 415748. Scrubbing with aqueous liquor, U.S.P. 2071329; 2190001; 2071357; 2128323. Dilution with a cool inert gas, U.S.P. 2664468.

Many methods of purification have been suggested including crystallisation from carbon tetrachloride or from toluene or without a solvent (U.S.P. 1301388; F.P. 648163; U.S.P. 2046368); passing the phthalic anhydride while still in the vapour state over such materials as alumina, pumice, silica gel, active charcoal (U.S.P. 1693915; 1852782; 1953937; B.P. 272557) or through molten phthalic anhydride containing sulphuric acid, or aluminium chloride (G.P. 512230). A very common method of purification would seem to be the heating of crude anhydride at various temperatures up to its boiling-point with or without added substances, followed by distillation or sublimation. Thus such heating with sulphuric acid is described in U.S.P. 2105911; with sulphuric acid followed by removal of excess acid with wood charcoal or alkali in U.S.P. 2118918 and 2309167 respectively; with sodium bisulphate in U.S.P. 1897110; with nitric acid in U.S.P. 2349518; with trioxymethylene in U.S.P. 1755242; with lactic or other hydroxy acids in B.P. 361443; with a mixture of sodium chloride and heavy metal oxides in Buss. P. 33147; with manganese dioxide and chlorine in U.S.P. 1702871; B.P. 285017; with stannous chloride in U.S.P. 2356449; with zinc chloride or sodium hydroxide in U.S.P. 1728225; and with finely divided iron or nickel plus a little hydrogen in U.S.P. 2091289.

All these methods of refining are carried out on the anhydride itself but in U.S.P. 1930054 an aqueous solution of the free acid is extracted with solvents and the purified acid recovered from the aqueous layer, whereas in U.S.P. 1943892 the acid is purified via an alkali metal salt by treatment with a hypohalite or a peroxide. Methods for separating phthalic anhydride from small amounts of naphthalene and benzoic acid are described in U.S.P. 1685624; 1694124; 1686913; 1892396; 1822016.

In almost every case any of the above methods of purification is preceded or followed by sublimation or distillation with or without fractionation. Patents covering sublimation are B.P. 174013; Canad. P. 202626; U.S.P. 1445870; 1484260. The size and shape of sublimed crystals are discussed by O. Dony (Bull. Acad. roy. Belg. 1932, 18, 1138). Vacuum distillation methods are described in B.P. 324840; U.S.P. 1910836; 1972157; 1993886; a fractional condensation method is described in B.P. 173789.

### Growth of Production and Uses of Phthalic Anhydride.

The published figures for the yearly production of phthalic anhydride in the U.S.A. tell a remarkable story of the expansion in production from the discovery of the vapour-phase oxidation process in 1917 until the end of the Second World War.

Year.	Production of phthalic anhydride in tons.	Price per lb in \$
1918 . . .	< 460	ca. 4-0
1929 . . .	4,100	0.15
1930 . . .	13,950	0.12
1942 . . .	42,320	0.14
1943 . . .	50,950	0.14
1944 . . .	54,800	0.13

Investigations in Germany have shown that the production there in 1942 was 12,250 tons, whereas it is thought that the present production in Great Britain is less than this figure.

The need for phthalic anhydride in the First World War was principally for dyestuffs. Synthetic indigo was made in the past from anthranilic acid which itself was made from phthalic anhydride, but this use was displaced when the phenylglycine route to indigo was discovered. Phillips (J. Ind. Eng. Chem. 1921, 13, 247; *cf. ibid.*, p. 363) lists several hundred dyestuffs and intermediates arising from phthalic anhydride, including the important xanthene class of dyes, quinoline yellow, anthraquinone, phthalins, etc. Many of these compounds and dyes are still made from the anhydride but by far the largest part of the production in recent years has gone to the manufacture of esters of phthalic acid and alkyd resins; thus, S. A. Phillips (Amer. Paint J. 1945, 29, No. 27, 60, 64, 66, 68) divides the American use of phthalic anhydride as follows: 60%, esters; 31%, resins; 6%, dyes and intermediates; 2%, food and drugs; 1%, miscellaneous uses. Apart from the use of esters of phthalic acid as plasticisers for many types of plastic, two further large uses developed during the recent war; first, dimethyl phthalate became widely used as a mosquito repellent, and secondly, dibutyl phthalate became important as a plasticiser for smokeless powder.

Since about 1930 phthalic anhydride has also become an important starting material for benzoic acid, which is now made on a large scale by the partial decarboxylation of the anhydride either in the liquid or vapour phase (*see* U.S.P. 1885834; 1929624; 1939212; 1889945; 1955050; 2088929; 2013973; 1988876; 1962175; 1693915; B.P. 341902; F.P. 680793).

### REACTIONS OF PHTHALIC ANHYDRIDE.

Phthalic anhydride enters very readily into many condensations and other reactions, some of which have become industrially important.

(1) Phthalic anhydride undergoes with facility a Friedel and Crafts reaction with benzene and other aromatic compounds to give *o*-benzoylbenzoic acid and other similar substances

(Friedel and Crafts, Ann. Chim. Phys. 1868, [iv], 14, 44fc G.P. 193961; Graebe and Ullmann, Annalen, 1896, 291, 9) (v. Vol. I, 4062).

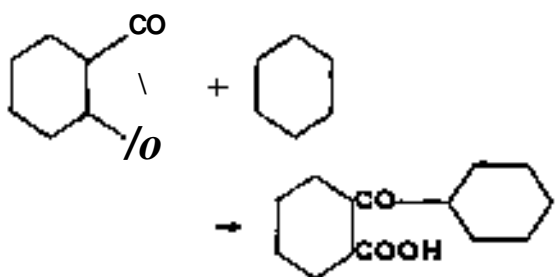

When this keto-acid is heated with sulphuric acid, cyclization occurs with the production of anthraquinone. This process has been used industrially in France and the U.S.A., where it is competitive with the alternative production of anthraquinone from anthracene. Very many substituted anthraquinones can be prepared by using aromatic compounds other than benzene. Thus quinizarin is manufactured by the condensation of phthalic anhydride with p-chlorophenol or hydroquinone, using concentrated sulphuric acid and boric acid at 200°.

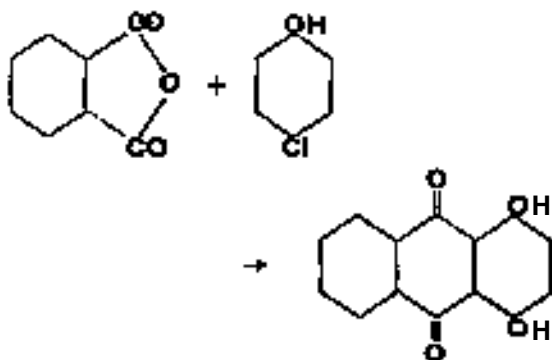

In this case the two stages of the reaction proceed together and also if p-chlorophenol is used the chlorine atom is replaced by a hydroxyl group. This reaction therefore provides a convenient route to many anthraquinone dyestuffs, and a very complete account of it will be found in Chapter IX of C. A. Thomas, "Anhydrous Aluminium Chloride in Organic Chemistry," Reinhold, New York, 1941.

(2) The reaction of phthalic anhydride with

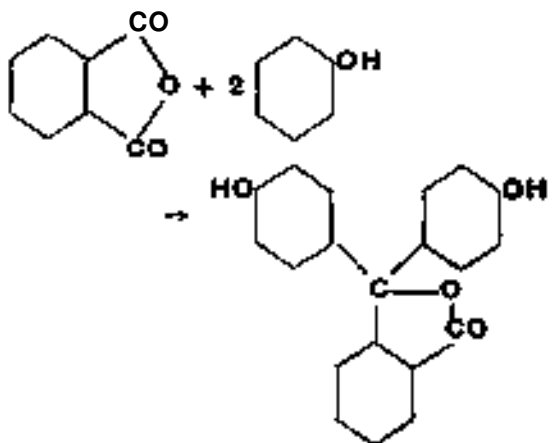

phenols in the presence of dehydrating agents such as sulphuric acid, zinc chloride, etc., to yield a class of colouring matter known as the phthaleins, was discovered by Baeyer in 1872 and has become industrially important both for the manufacture of dyestuffs, such as fluorescein from resorcinol, and for the production of the simplest member of the class, viz. phenolphthalein.

(3) Condensation products of phthalic anhydride and glycerol and other polyalcohols have become very important as alkyd or glyptal resins, which to-day consume more phthalic anhydride than any other product except perhaps phthalic esters.

(4) Grignard reagents can give rise to dialkyl- and diaryl-phthalides

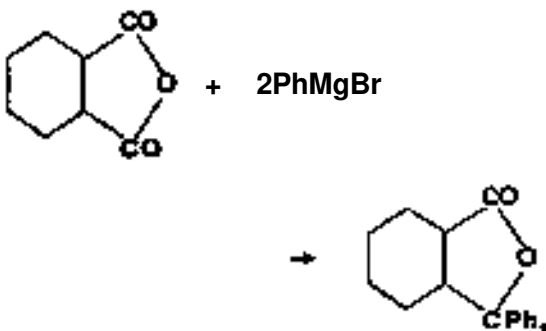

(Bauer, Ber. 1904, 37, 735; 1905, 38, 240), or monoarylhydroxyphthalides, which with water yield keto acids:

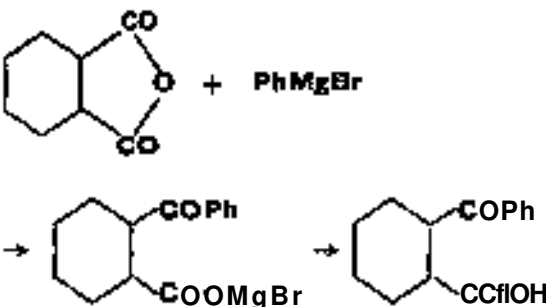

(Pickles and Weizmann, Proc. Chem. Soc. 1904, 30, 201; Weizmann, Bergmann, and Bergmann, J.C.S. 1935, 1367). The latter is claimed as a less ambiguous route to substituted benzoylbenzoic acids (and hence anthraquinones) than the Friedel and Crafts reaction. Phthalic anhydride also reacts readily with cadmium alkyls made from cadmium chloride and a Grignard reagent to give an addition compound, which with 10% sulphuric acid gives acylbenzoic acids:

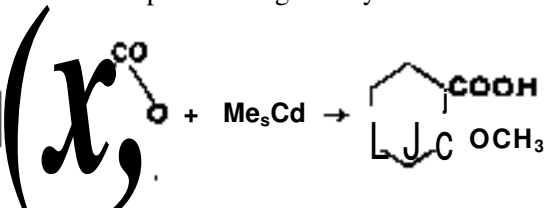

(De Benneville, J. Org. Chem. 1941, 6, 462).

(5) With a-picoline, lutidines, or quinaldine,

phthalic anhydride undergoes the "phthalone reaction," e.g.,

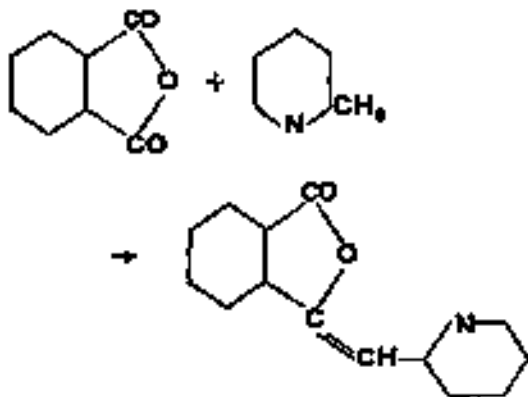

(Düring, Ber. 1905, 88,161; Eibner, *ibid.* 1904, 87, 3605; Scholze, *ibid.* 1905,88,2806; Langer, *ibid.*, p. 3704).

(6) With amines and amino acids phthalic anhydride gives substituted phthalamic acids or phthalimides; thus with glycine it yields phthalyl glycine

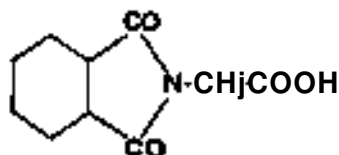

or substituted phthalamides (Tingle *et al.*, J. Amer. Chem. Soc. 1910, 32, 113, 1319; Vanags and Veinberg, Per. 1942, 75 [B], 1558). The reaction of hydrazine has been the subject of long controversy; Drew and Hatt (J.C.S. 1937, 16) give a good review of the literature and show that in acetic acid the reaction with equimolecular quantities of reactants gives (I) and (II) probably via the half-hydrazide (IU); (II)

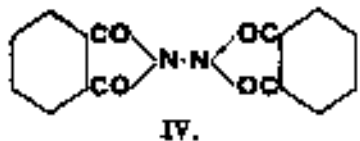
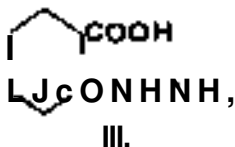
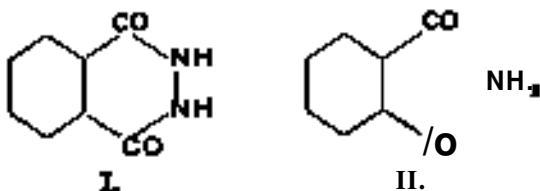

formed 60% of the mixture, whilst prolonged action gave only (I). Excess phthalic anhydride gives a mixture of (I) and N-phthalimidophthalimide (IV).

### Esters and Halides.

Acid esters of very many alcohols have been prepared and are widely used in the laboratory for characterising and purifying alcohols. Gogans and Copenhaver (J. Amer. Chem. Soc. 1937, 61, 2909) describe the preparation of alkyl acid phthalates from normal alcohols containing from 1 to 20 carbon atoms. Melting-points of all the derivatives are given for the lower alcohols up to butyl. The esters are prepared merely by refluxing a mixture of phthalic anhydride and the alcohol. The half esters of some secondary alcohols are prepared by Levene and Mikeska (J. Biol. Chem. 1927, 75, 594) by heating a mixture of the anhydride, alcohol, and pyridine. Tertiary alcohols do not easily form esters but Fessler and Shriner (J. Amer. Chem. Soc. 1936, 58, 1384) describe their preparation by reaction in dioxan solution at 60-55°c. of the Grignard reagent from the tertiary alcohol with phthalic anhydride.

Acid esters of secondary alcohols have been used extensively for resolving racemic alcohols (e.g., the work of Kenyon, J.C.S. 1907,91, 2058; 1911,99,58; 1913,103,1937; 1926, 2052, etc.). Purification of alcohols via these half esters is exemplified in the case of *t*-butanol (Hiickel and Ackermann, J. pr. Chem. 1933, fii], 136,15). Some industrial uses of these half esters and their derivatives have been suggested. Thus, metallic salts are claimed as paint dryers (U.S.P. 1742506; 2087999; F.P. 838475); also, some metallic salts are described as resin-like substances, insoluble in water, soluble in organic solvents, and useful for dissolving nitrocellulose (U.S.P. 1779654; 1779688). The acid esters made from higher fatty alcohols are claimed as softeners for leather. Sodium, potassium or lithium salts of higher alkyl acid phthalates are described as detergents for use in lubricating oils, whereas vanadyl oleyl phthalate is claimed as an oxidation inhibitor for lubricating oils.

Neutral esters of very many alcohols have been prepared, and several are produced on a large scale to constitute one of the chief uses of phthalic anhydride. Published figures for American production of the important esters and the total quantities are as follows:

	Production in lbs.	
	1936.	1944.
Dimethyl phthalate	---	42,837,000
Diethyl "	700,686	3,478,000
Dibutyl "	5,644,166	47,810,000
Total . . .	10,273,647	116,810,000

British figures are not available but it is certain that a considerable increase in production has occurred since 1936. This remarkable increase in production as shown by the American figures is due to the extensive use of phthalates as plasticisers for polymers, themselves undergoing great expansion, to the use of dibutyl

phthalate as a plasticiser for smokeless g'inpowder and t% the discovery and use of dimethyl phthalate as an insect repellent. The phthates provide tftt most m widely adaptable group of esters fos use as plasticisers. Dibutyl phthalate is the most widely used plasticiser for cellulose nitrate lacquers and is used also in many other reams such as cellulose acetate, ethyl cellulose, poly vinyl acetate and chloride, acrylates, methacrylates, rubber hydrochloride, etc. Dflethyl and dimethyl phthalates are pfobably the most used a/ter dibutyl phthalate and are often employed mixed together for cellulolb acetate and cellulose acetate-butyrate compositions. Dimethyl phthalate is also used to some extent for plasticisation in much the same way as the dibutyl es?er. JDuring the war dioctyl phthalates (especially that .from 2-ethylhexanol) have become useful as plasticisers, especially for polyvinyl chloridt and other compositions which are required to keep their properties at low temperatures. Other esters such as the glycollates (e.g., methyl phthalyl ethyl glycoll&e) anc^those made from glycols and glycol ethers are also used to some extent. Diethyl phthalate is also used extensively as a denaturant for alcohol. A list of some of the most important phthalates together with their "physical properties is given in Table V? For vapour pressure curves of several phthalates, see Hickman, J. Franklin Inst. 1936, 221, 383).

The alkyl phthalates are prepared by conventional routes, sulphuric acid being favoured as a catalyst. The removal of water formed during the esterification is carried out in several ways. G.P. 516135, describes the use of toluene to remove the water in an azeotropio mixture; U.S.P. 1732392 claims a similar" method under pressure. In U.S.P. 1864893 the mixture is distilled under reduced pressure to remove the water together with some alcohol. U.S.P. 2169012 describes the gradual addition of alcohol to a mixture of phthatic anhydri4e and catalyst well above the boiling-point of water. Ustinov (Org. Chem. Ind. Buss. 1937, 3, 291) passes the distillate from the reaction mixture through a layer of salt to remove water and returns the dry alcohol to the still. Gordon and Aronowitz (Ind. Eng. Chem. 1945, 37, 780) obtain a good yield of dioctyl phthalate by refluxing the reaction mixture below a column containing the desiccant " fluorite" Several methods of purification of the esters have been patented and include decolorisation by aeration, absorption or chemical bleaching followed by distillation (U.S.P. 2130014), treatment with aqueous permanganate (U.S.P. 1905974), exposure to ultraviolet light (U.S.P. 1948281), refluxing with sodium perborate under reduced pressure followed by distillation (U.S.P. 2197546), and continuous flash distillation (U.S.P. 2324088).

The dialkyl phthalates are colourless liquids when molten, and are stable to heat and boiling water. They are reduced by nickel catalysts, under pressure and at 200°c, to dialkyl hexahydrophthalates (B.P. 286201; Adkins *et al.*, J. Amer. Chem. Soc. 1933, 55,1669), but copper chromite catalyst at 250°o. gives mainly o-xylene.

Kyrides (U.S.P. 1939216; J. Amer. Chem.

Soc. 1933, 55, 4630) has suggested the use of the reaction between alkyl phthalates and asymmetric phthalyl chloride in the presence of 0\*2% zinc chloride at 130°o. for the production of alkyl chlorides.

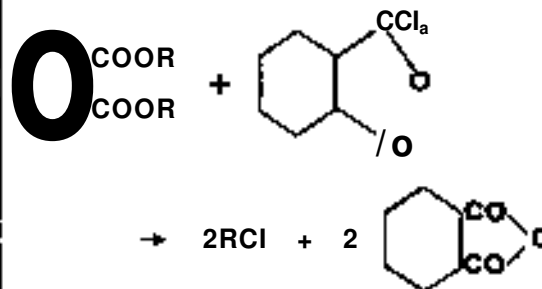

(See Amitin and Hirshberg, Amer. Chem. Abstr. 1937,31,6610, for some exceptions.)

King and Wright (J.C.S. 1939, 1168) utilise alkyl phthalates to produce phenyl and guaiacol ethers by direct reaction with the potassium salts of phenol and guaiacol, respectively at 190-200°c. For the use of dimethyl phthalate as an insect repellent, see Phillip, Paul, and Sabin (War Medicine, 1944, 6, 27), and Lancet, 1944, 664; 1946, 571; v. this Vol., p. 312c. This now represents a very large usage of this ester.

Diethyl phthalate is covered by the British Standard 574/1934. Dibutyl phthalate is covered by British Standard 573/1934 and by the A.S.T.M. Designation D.608—43. Its vapour pressure has been measured by Hickman *et al.* (Ind. Eng. Chem. [Anal.], 1937, 9, 264) who deduced 21,400 g. caL per mol. as the heat of vaporisation between 50-100°o. Ambler (J.S.C.I. 1936, 55, 291T) records the heat of combustion and formation. The preparation of di-sec.-butyl phthalate is described along conventional lines in U.S.P. 1848155, but a good yield is also claimed by the addition of 2-butene to phthalic acid at 97°c. in the presence of boron trifluoride (Amer. Chem. Abstr. 1939^33, 5805). Many other alkyl phthalates are described in the patent literature and include butyl hexyl phthalate (U.S.P. 2384537); di-2-butyl-octyl phthalate (U.S.P. 2014310); di-2-ethylbutyl phthalate (U.S.P. 1972579); di-«ec.-hexyl, -heptyl, and -octyl phthalates (U.S.P. 1949093); higher alkyl phthalates (U.S.P. 2015077; 2015088; 2166934).

Esters from cyclic alcohols include di-cyclopentyl phthalate (U.S.P. 2237729); cyclohexyl alkyl phthalates (U.S.P. •1543383; 1689761 and 2); di-hexahydrobenzyl phthalate (U.S.P. 2047663); bornyl and fenchyl phthalates (U.S.P. 2011707). The preparation of alkyl phthalyl alkyl glycollates of general formula.

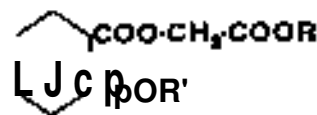

is described in U.S.P. 2073937 and 2120755. Phthalates made from glycols and glycol ethers are described in U.S.P. 1706639; 1786404; 1946202; 2013318; 2386443; B.P. 410797; 584196. Aryl and alkyl aryl phthalates are described in U.S.P. 1700960; 1899919; 1989699; 1939217; 1984283 and 4; 2079487; 2378753.

TABLE V.—ESTERS OF PHTHALIC ACID.

Ester.	B. p., °C.	M. p., °C.	$n_D^{20}$	$n_D^{25}$	$d_4^{20}$	Ct.	80L/H <sub>2</sub> O, %.	Flash point (open cup), °C.	Viscosity centipoises.	Vapour pressure, mm. mercury.
Dimethyl phthalate . . . . .	282; 190/50 mm.	5-5	1-513/25°	M9341	1,120-4	1,120-1	0-4/32°	149	36-1/10°	<001/25°O.
Diethyl phthalate . . . . .	295	-40	1-499/25°	1-122 <sup>20</sup> <sub>20</sub>	—	—	0-058/30*	152	10-6/10°	<001/25°C.
Bipropyl phthalate . . . . .	129-132/1 mm.	—	1-494/25°	1071''°	—	—	0016	—	—	—
Dibutyl phthalate . . . . .	340; 206/20 mm.	ca. -35	1-4905/25°	1047S:	245	237	0001/30°	170	32-9/10 <sup>0</sup> 19-7/20°	00001/25°C.
Diamyl phthalate . . . . .	342	<-55	1-488/25°	102223°	198	205	001	171	—	—
Di(methoxyethyl) phthalate . . . . .	185-210/4 mm.	<-40	1-500/25°	1-17020°	—	—	0-833	180	—	<0-01/20°C
DKethoxyethyl phthalate . . . . .	200-214/4 mm.	31	1-492/25°	1-12020°	—	—	0-3/30°	180	—	<0-01/20°C.
DKbutoxyethyl phthalate . . . . .	212-232/4 mm.	<-50	1-482/25°	106320-	—	—	<0-1/25°	202	—	—
Dicapryl ( <i>i.e.</i> , 2-ethylhexyl) phthalate . . . . .	220-235/4 mm:	<-55	1-480/25°	0-96523° 0-98620 <sup>8</sup>	—	—	<003	201	64/25°	<001/20°C.
Methyl phthalyl ethyl glycollate . . . . .	189/5 mm.	<-35	1-504/25°	1-220W	—	—	000/30°	190	454-8/10° 100-3/20 <sup>0</sup>	—
Ethyl phthalyl ethyl glycollate . . . . .	190/5 mm.	30	1-498/25°	1-18023°	—	—	00175/30°	193	210-7/10° 630/20°	—
Butyl phthalyl butyl glycollate . . . . .	219/5 mm.	<-35	1-490/25°	1-1801 <sup>20</sup>	—	—	0000/30 <sup>0</sup>	193	136-5/10° 51-3/20''	—
Diphenyl phthalate . . . . .	255/14 mm.	W-73	1-572/74°	1.2823°	—	—	Insol.	224	—	—
Bis-diethylene glycol mono-ethyl ether phthalate	200-260/4 mm.	<-15	1-486/25°	1-18-1-15	—	—	0C/25 <sup>0</sup>	208	—	—

PHTHALIC ACID.

Phthalates made from aliphatic nitro alcohols are described in U.S.P. 2161552; 2274568. Diallyl phthalate has found some special uses, especially in the production of polymerizing thermo-setting resins (U.S.P. 2377095 and 2311327), as a plasticiser and softener in synthetic rubber mixes (U.S.P. 2380184), and as a plasticiser and modifier in the polymerisation of styrene (U.S.P. 2159008).

Phthalyl Chloride exists in two isomeric forms.

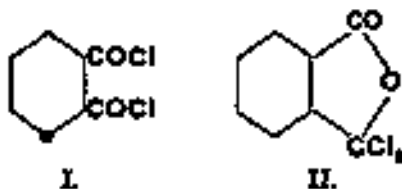

The symmetrical chloride (I) is formed by the action of phosphorus pentachloride on phthalic anhydride (Auger, Ann. Chim. Phys. 1891, [vi], 22, 295; Ott, Org. Syntheses, (coll. Vol. II, p. 528) or by thionyl chloride in the presence of zinc chloride (Kyrides, J. Amer. Chem. Soc. 1937, 59, 206). The first reagent gives a yield of about 92% and the latter a yield of approximately 100% with a conversion of 86%. The structure of this chloride is based upon physical measurements and its ultra-violet light absorption (Scheiber, Ber. 1912, 46, 2352). It melts at 15-16° and boils at 276-7° (Ott, Annalen, 1912, 892, 245). It is an excellent reagent for making acid chlorides (Kyrides, *I.e.*).

The symmetrical chloride is converted by aluminium chloride to (II), m.p. 88-89°, b.p. 275-2°/19 mm. (Ott, *ibid.* 1912, 392, 274; Ber. 1922, 65, 217). The equilibrium between these two isomers has been studied by Csanyi (Monatsh. 1919, 4b, 81). As well as the difference in physical properties between these two compounds, considerable difference is found in their chemical reaction. Thus (II) with methanol and precipitated chalk give methyl pseudophthalate.

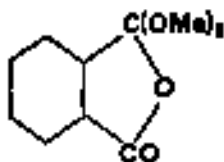

m.p. 53°c, which on heating gives the normal methyl phthalate (Kirpal, Galuschka, and Lassak, Ber. 1935, 68 [B], 1330). Different products result also with salts of dithiocarbamic acids,

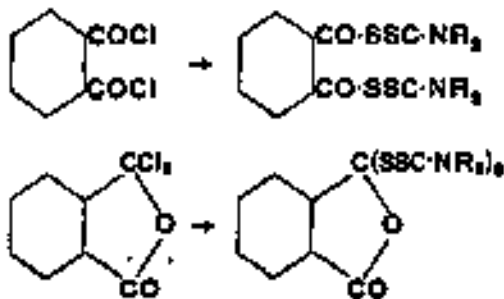

Both chlorides are reduced by zinc and acetic acid to phthalide; both, with benzene and aluminium chloride, give diphenylphthalide; and both, with ammonia, give 2-cyanobenzoic acid. Excess phosphorus pentachloride on the phthalyl chlorides gives, respectively,

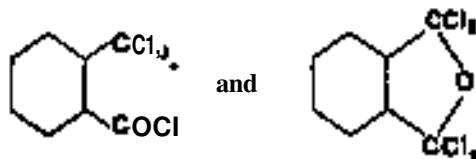

(Ott, Ber. 1922, 55, 2108).

**Phthalyl Bromide.**—The preparation and tautomerism are described by Davies, Hambly, and Semmens (J.C.S. 1933, 1309). It is made either by the reaction of phosphorus tri- and penta-bromides on phthalic anhydride in sealed tubes, or by reaction between phthalyl chloride and dry hydrogen bromide. It melts at 78-81° with rapid heating, but never sharply. It is suggested that the crystals are of the cyclic form, passing over to the symmetrical structure when kept for a few minutes in the molten state; the reverse change takes place spontaneously on cooling.

**Phthalyl Fluoride** exists only in the symmetrical form and can be made by heating the symmetrical phthalyl chloride with sodium fluoride; it is lachrymatory, less readily hydrolysed than the chloride, and melts at 42-43°.

**Nuclear Halogen Derivatives.**

Most of the possible halogenated phthalic acids and anhydrides are known and a list is given in the accompanying table:

Substituents.	M.p. of add., °.	M.p. of anhydride.
3-Cl	184	164
3-Br	178-5	111-5
3-I	206	153
4-Cl	161	97
4-Br	169	107
4-I	182	123
3:4-Cl <sub>a</sub>	195	120-121
3:4-Br <sub>a</sub>	194-195	152-153
3:4-I <sub>a</sub>	212-213	198-198-5
3:5-OI,	164	89
3:5-Br,	198	121-5
3:5-Cl,	*	191
3:6-Br <sub>t</sub>	135	207-5-208
3:6-I,		234-5-235-5
4:5-Cl,	200	185-187
4:5-Br <sub>1</sub>	206	208
4:5-I,	221-222	216-5-217
4-Cl-5-Br	205	185
3:4:5-Cl <sub>3</sub>		157
3:4:6-Cl <sub>3</sub>		148
3:4:5 or 6-Br <sub>3</sub>	190-191	157
4-Br-3:5-Cl <sub>t</sub>	169-170	170-171
Cl <sub>4</sub>	258-9	266
Br <sub>4</sub>	325	324-327

\* Decomposition to anhydride before melting.



The mono-halogen derivatives are prepared by the following methods:

(1) *Direct Action of the Halogen on a Solution of Phthalic Acid, Usually Alkaline.*—It is only possible to produce the 4-halogeno-phthalic acids in this way. Thus chlorine passed into an alkaline solution of phthalic acid gives 4-chlorophthalic acid (Moore, Marrack, and Proud, J.C.S. 1921, 119, 1178; Ayling, *ibid.* 1929, 253); a neutral solution of disodium phthalate is used in U.S.P. 2389088. Bromine and sodium hypobromite give with sodium phthalate a good yield of 4-bromophthalic acid (Waldmann, J. pr. Chem. 1930, [ii], 126, 65; *see also* U.S.P. 2211465; 2394268). Iodine in the presence of nitric acid yields the 4-iodo-acid (Datta and Ghattejee, J. Amer. Chem. Soc. 1919, 41, 292).

(2) *Replacement of a Nitro Group by Chlorine.*—This has been done using chlorine or bromine gas at about 240° to give 3- or 4-chloro-, trichloro-, or bromo-phthalic anhydride (B.P. 357165) or by using phosphorus pentachloride at 190-200°. (Smith, J.C.S. 1933, 1643). This reaction is apparently general. #

(3) *Oxidation of the appropriately substituted o-xylene (e.g., 3-bromo- and 3-chloro-phthalic acids from 3-bromo- and 3-chloro-o-xylenes, (Guareschi, Ber. 1886, 19, 135).*

(4) *By use of the Sandmeyer reaction on the appropriate amino-phtalic acid.*—This method is quite general and has been much used; *see* Endinger (J. pr. Chem. 1896, [ii], 53, 386), Stephens (J. Amer. Chem. Soc. 1921, 43, 1950), Baker (J.C.S. 1928, 2829), and Blicke and Smith (J. Amer. Chem. Soc. 1929, 51, 1865).

The di-halogeno-derivatives have been largely prepared by oxidation of the appropriately substituted xylenes, but Williger (Ber. 1909, 42, 3530) showed that phthalic anhydride in fuming sulphuric acid could be chlorinated to give a mixture of di-chlorophthalic acids containing mostly the 3-6-derivative, a small quantity of the 3:4, and very little of the 4:5-derivative. Separation was possible through the zinc salts (*cf.* G.P. 50177). A separation is also feasible by taking advantage of the different rates of anhydride formation of the various dichlorophthalic acids (B.P. 396735). Direct chlorination of molten phthalic anhydride containing a little ferric salt can be made to produce a mixture of dichlorophthalic anhydrides if the chlorination is stopped when the required increase in weight has taken place, U.S.P. 2028383). Phthalic anhydride can also be chlorinated to the dichloro-derivatives by using 2 mol. of ferric chloride per molecule of anhydride at 300°. (B.P. 572160).

The tetrahalogen derivatives are formed by the action of the halogen at high temperatures in fuming sulphuric acid with or without antimony chloride (Gnehm, Annalen, 1887, 238, 320; Hupps, Ber. 1896, 29, 1630; Pratt and Perkins, J. Amer. Chem. Soc. 1918, 40, 203; G.P. 32564; 50177). A more convenient method of production is to chlorinate molten phthalic anhydride with gaseous chlorine in the presence of a little ferric salt at a temperature rising from 160° to 260° until the required increase in weight takes place (U.S.P. 2028383). Chlorination beyond this required increase in weight gives rise to the formation of hexachlorobenzene

(D'ornikoff, Sheets, and Zienty, J. Amer. Chem. Soc. 1946, 68, 142). 3

Esters of chlorophthalic acids containing two to four chlorine atoms and made from alcohols containing less than six carbon atoms have been suggested as plasticisers for polystyrene, cellulose esters, and other polymers (B.P. 576136). Both the dichloro- and the tetrachloro-phthalic anhydrides are available commercially in the U.S.A., and find use as intermediates for dye-stuffs and alkyd resins of special properties.

#### Nitrophthalic Acid's.

Both phthalic acid and phthalic anhydride can be nitrated with fuming nitric and sulphuric acids to give a mixture of 3-nitro- and 4-nitrophthalic anhydride (Miller, Annalen, 1881, 208, 223; Bogert and Bořoschek, J., Amer. Chem. Soc. 1901, 23, 743; Kennel\* and Mathews, J.C.S. 1914, 105, 2476; Lawrance, J. Amer. Chem. Soc. 1920, 42, 1872; Hayashi and Kawasaki, J. Soc. Chem. Ind. Japan, 1933, 86, Suppl. binding, 121). Detailed laboratory instructions are given in Organic Syntheses, Coll. Vol. I, 2nd ed., p. 408. Approximately equal quantities of both the 3- and 4-nitroanhydride are formed and are separated by converting to the acids, washing well with water to dissolve most of the 4-nitrophthalic acid and crystallising the 3-nitrophthalic acid from water. Some variations in this method have been proposed by Littmann, who also claims glacial acetic acid as a better solvent than water for crystallisation (J. Amer. Chem. Soc. 1925, 47, 1980; U.S.P. 1549885). The acids are easily and quantitatively converted to the respective anhydrides either by heating alone or by refluxing with excess acetic acid at 100°. With concentrated nitric acid and boron trifluoride, phthalic anhydride gives a yield of 81% of the 3-nitrophthalic acid (Thomas, Anzilotti, and Hennion, Ind. Eng. Chem. 1940, 32, 408).

3-Nitrophthalic anhydride has been used for the characterisation of alcohols and mercaptans (Nicolet and Sacks, J. Amer. Chem. Soc. 1925, 47, 2348; Wertheim, *ibid.* 1929, 51, 3661).

Melting-points of the nitrophthalic acids and anhydrides are as follows: 3-nitro-acid, 218°; 3-nitro-anhydride, 164°; 4-nitro-acid, 165°; 4-nitro-anhydride, 119°.

#### Sulphophthalic Acids.

4-Sulphophthalic anhydride can be prepared by heating phthalic acid or anhydride with four times its weight of fuming sulphuric acid at 215°. (Senderens and Aboulenc, Compt. rend. 1928, 186, 1497), by passing sulphur trioxide into phthalic anhydride for 66 hours at 190-210° (Waldmann and Schwenk, Annalen, 1931, 487, 287), or by the action of sulphur trioxide on phthalic anhydride under pressure (G.P. 572962; 578724). 4-Sulphophthalic acid crystallises from water with 1 mol. of water of crystallisation, has m.p. 138-140°, and yields 4-hydroxyphthalic acid when fused with sodium hydroxide at 220°. 3:5-Disulphophthalic acid is obtained by the action of oleum on phthalic anhydride (B.P. 18221) or on 3-sulphophthalic acid (Lauer, J. pr. Chem. 1933, [iii], 188, 81). The presence of

mercury increases the production of disulphuric acid formed under various conditions of sulfonation.

Phthalimide, Amides, and Nitrile.

Phthalimide,

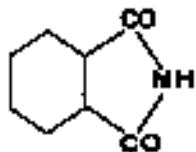

is best prepared in the laboratory in 95-97% yield by heating phthalic anhydride with excess concentrated ammonia solution or ammonium carbonate to a temperature of about 300°C. The product is nearly pure, m.p. 232-235° (Organic Syntheses, Coll. Vol. I, 2nd ed., p. 457). The same method is used industrially with or without pressure. Continuous production has been suggested, by the catalytic vapour-phase oxidation of 1-nitronaphthalene (B.P. 183044) or of naphthalene in the presence of ammonia (U.S.P. 1450678; for purification see U.S.P. 1914723).

Phthalimide forms needles from water, prisms from acetic acid, and leaflets by sublimation. It melts at 233-235°C, is soluble in hot acetic acid, insoluble in benzene and light petroleum.

Phthalimide is acidic in nature ( $K=5 \times 10^{-6}$ ) and forms a potassium salt with potassium hydroxide. The reaction of this potassium salt with alkyl chlorides, aryl chlorides, and other chloro compounds allows the preparation of many N-substituted phthalimides (see, *inter alia*, Sörqnsen, Z. physiol. Chem. 1905, 44, 448; Organic Syntheses, Coll. Vol. II, p. 83).

Use is made of this acidic nature of phthalimide in the Gabriel synthesis of primary amines, in which the N-alkyl phthalimides are hydrolysed by boiling aqueous potassium hydroxide to alkylamine and potassium phthalate,

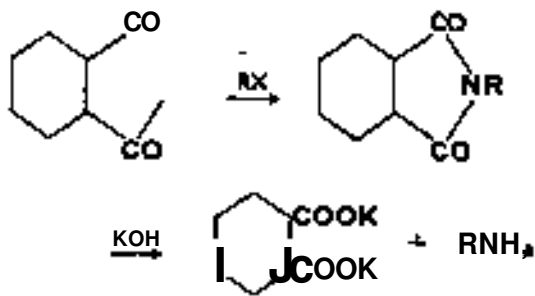

The method can be used for the preparation of amino acids, giving good yields of high-purity material; thus using chloroacetic acid, glycine can be prepared. In place of potassium hydroxide for the hydrolysis, hydrazine hydrate can be advantageously used in many cases (Ing and Manske, J.C.S. 1926, 2349) and this method has found especial use in synthesis of anti-malarial substances (Robinson *et al.*, *ibid.* 1934, 1524; 1943, 555; Barber and Wragg, Nature, 1946, 158, 514).

With cold aqueous sodium hydroxide, phthalimide yields the sodium salt of phthalamic acid and subsequent acidification liberates the free

phthalamic acid. Anthranilic acid is formed in good yield by the action of sodium hypochlorite on phthalimide in alkaline solution at 80°C.; the phthalamic acid first formed undergoes the Hofmann reaction

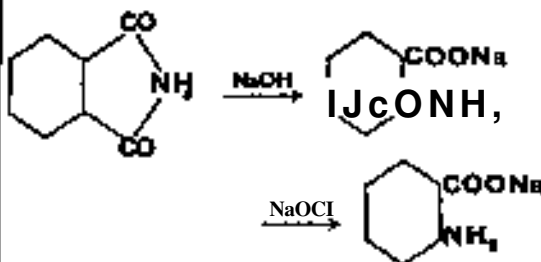

This reaction is the first stage in the Heumann synthesis of indigo.

Phthalamic Acid,

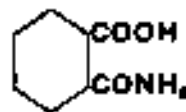

is prepared in 94% yield by adding phthalic anhydride to warm ammonium hydroxide, cooling to give crystalline ammonium phthalamate and acidification of this salt with dilute hydrochloric acid. Phthalamic acid melts at 149° with loss of water to give phthalimide. It is moderately soluble in hot water.

Phthalimide,



can be prepared by the reaction of phthalimide in the cold with concentrated ammonia solution. It melts with slow heating at 272-270° to give ammonia and phthalimide. It is sparingly soluble in water and in alcohol.

Phthalonitrile,

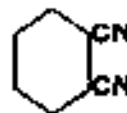

formerly prepared by the use of the Sandmeyer reaction, is now made on both laboratory and industrial scale by the dehydration of phthalamide with phosphorus tri- or oxy-chloride, or toluenesulphonyl chloride (Swiss Pat. 202545; U.S.P. 2387435) or with phosgene in the presence of a tertiary base such as pyridine (B.P. 441399), or at 485-490° in the presence of ammonia (B.P. 4\*3639). Reaction of phthalic anhydride and ammonia over a suitable catalyst (aluminium phosphate, magnesium silicate, etc.) at high temperatures for a short time provides another process for manufacture (F.P. 847296; U.S.P. 2149280; 2232836).

Phthalonitrile forms odourless needles, m.p. 140°, is volatile in steam and can be distilled. It is the raw material for manufacture of the phthalocyanines.

## Aldehydes.

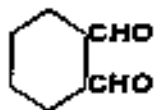
*Phthalaldehyde,*

is prepared by refluxing wtetrabromo-o-xylene with potassium oxalate in aqueous alcohol (Thiele and Günther, *Annalen*, 1906, 347, 107). It may also be prepared, together with *iso*-phthalaldehyde, by the action of chloroform and potassium hydroxide on benzaldehyde, followed by hydrolysis of the intermediate products formed (Chaudhuri, *J. Amer. Ghem. Soc.* 1942, 64, 315). The aldehyde, yellow needles, m.p. 56-57°, is soluble in water and in most organic solvents except light petroleum. It is volatile in steam and yields a *bisphenylhydrazone*, m.p. 190-191°.

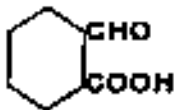
*Phthalaldehydic Acid,*

may be prepared from naphthalene by oxidation with alkaline permanganate; yield, 38% (*Organic Syntheses*, Coll. Vol. II, 1943, p. 523). Alternatively, it may be prepared in 65-68% yield by the bromination of phthalide, followed by the hydrolysis of the 2-bromophthalide thus formed (*Organic Syntheses*, 1943, 23, 74). The acid crystallises from water as leaflets, m.p. 98-99°, it is soluble in alcohol and in ether. It reduces ammoniacal silver nitrate solution and on heating to 240-250° it is converted to diphthalidyl ether. *Semicarbazone*, m.p. 202°; *phenylhydrazone*, m.p. 106°.

## o-PHTHALIC ACID,

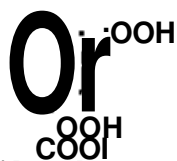

o-Phthalic acid can be prepared by oxidation of *m*-xylene with potassium permanganate or with chromic acid, but better yields are obtained if the *m*-xylene is first converted into the dibromide by bromination at 125°; this is then either treated with hot alcoholic potassium hydroxide (Kipping, *Ber.* 1888, 21, 46) or with sodium acetate (Williger, *Annalen*, 1893, 276, 256) to give the diol or diacetate, which is finally oxidised. Ullmann and Uzbachian (*Ber.* 1903, 86, 1798) describe the oxidation of *m*-xylene itself with calcium permanganate. Several other syntheses of the acid are known.

*Physical Properties.*—*Slender* needles from water, m.p. 348.5°. Sublimes unchanged. One part soluble in 7,800 parts of water at 25° and in 460 parts at 100°. Easily soluble in alcohol.

*Chemical Properties.*—When heated, sublimes unchanged (differing from *o*-phthalic acid). However, on heating with acetic anhydride to 200°, it gives a polymeric anhydride, which is

nonvolatile, insoluble in water and decomposed by heat (Bucher and Slade, *J. Amei. Chem. Soo.* 1909; 31, 1319). Reduction with sodium amalgam yields a mixture of tetrahydrophthalic acids.

*Characterisation and Determination.*—*Di-phenyl ester*, m.p. 120°; *-p-nitrobenzyl ester*, m.p. 202.5°; *phenacyl ester*, m.p. 191°; chloride and dimethyl ester are also characteristic.

*Hydroisophthalic Acids.*—See Ferkin and Pickles (*J.C.S.* 1905, 87, 293); Perkin and Goodwin (*ibid.* 841); and Baeyer and Villiger (*Annalen*, 1893, 276, 255).

*Esters.*—*Dimethyl ester*, m.p. 67-68°, b.p. 124°/12 mm. *Diethyl ester*, m.p. 11-5°, b.p. 170°/24 mm. *Methyl hydrogen ester* exists in two forms, m.p., 193° and 167-169°. *Ethyl hydrogen ester*, m.p. 115-117°.

*Phthalyl Chloride*, m.p. 43HL4°O., b.p. 276° is formed by the action of phosphorus pentachloride or acetyl chloride on the acid.

*Chloro-substituted Phthalic Acids* are prepared by oxidation of the suitably substituted xylenes or by the Sandmeyer reaction. Chlorination of the acid in the presence of sulphuric acid at a high temperature gives much hexachlorobenzene and not much of the tetrachlorophthalic acid. Melting-points of known chloro-acids are as follows: 4-chloro-, 294.5°; 5-chloro-, 278°; 4,6-dichloro-, 280°; tetrachloro-, 267-269°. Several other halogen-substituted isophthalic acids are known, melting-points being as follows: 4-bromo-, 283°; tetrabromo-, 288-292°; 2-iodo-, 236-238°; 4-iodo-, 269°; 5-iodo-, 288-289°; and tetraiodo-, 315-320°.

*Nitro-Compounds.*—Direct nitration of *o*-phthalic acid with concentrated nitric acid at 30° gives mostly 5-nitro- and a little 4-nitro-isophthalic acids. The 2-nitro- and 4-nitro-isophthalic acids are prepared by oxidation of the corresponding nitro-*m*-xylenes with alkaline permanganate; melting-points of the three nitro acids are as follows: 2-nitro-, 315°; 4-nitro-, 258-259°; 5-nitro-, 248-249°.

*Sulpho-isophthalic Acids.*—Direct sulphonation gives chiefly 5-sulpho-isophthalic acid (i.e., meta to —COOH), m.p. 243-244°.

*o*-Phthalaldehyde is prepared in good yield by either boiling *o*-tetrabromo-*m*-xylene with potassium oxalate in aqueous alcohol (Thiele and Günther, *Annalen*, 1906, 347, 109) or by the catalytic reduction of *o*-phthalyl chloride (Rosenmund, *Ber.* 1921, 54 [B], 2888). The aldehyde forms colourless silky needles, m.p. 89.5°, and gives a *bisphenylhydrazone*, m.p. 242-245°.

## TEREPHTHALIC ACID,

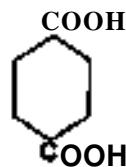

Terephthalic acid is formed by the oxidation of most derivatives of benzene having carbon chains in the para position. Baeyer describes

oxidation with alkaline permanganate of the diacetate prepared from dibromo-p-xylene and potassium acetate in absolute alcohol (Annalen, 1888, 245? 139). Like the *o*-acid, terephthalic acid has not been available commercially up to the present, but the recent discovery of "Terylex," which shows the condensation product of terephthalic acid and ethylene glycol to be a promising polymer for textile use, may foreshadow the large-scale production of this acid.

**Physical Properties.**—Terephthalic acid sublimes without melting at 300°. One part is soluble in 67,000 parts of water and it is also sparingly soluble in alcohol, acetic acid, ether, and chloroform.

**Chemical Properties.**—Like the *o*-acid, terephthalic acid yields a polymeric non-volatile anhydride when heated with acetic anhydride at 200°. with solution of a copper salt. In the presence of pyridine, terephthalic acid gives a copious white precipitate, enabling this acid to be detected in the presence of the other isomeric phthalic acids (Ripan, Bull. Stiinte Cluj, 1927, 3, 308).

**Characterisation and Determination.**—The calcium, barium, and strontium salts are all fairly insoluble, 1 part of the barium salt being dissolved by 355 parts water at 5°. The copper complex mentioned above gives a convenient means of detecting down to 2 mg. Convenient derivatives are the *diphenyl* ester, m.p. 192-2°; *p*-nitrobenzyl ester, m.p. 263-5°, and also the *dimethyl* and *diethyl* esters.

**Hydroterephthalic Acids.**—All the possible hydroterephthalic acids have been investigated by Baeyer (Annalen, 1888, 245, 142; 1889, 251, 257; 1890, 258, 32; 1892, 269, 148).

**Esters.**—The *dimethyl* ester forms needles or plates, m.p. 140°C; the *diethyl* ester forms long prisms, m.p. 43-2°C, b.p. 302° and 142°/2mm.

**Terephthalyl Chloride** is formed by the action of phosphorus tri- or oxy-chloride on the acid, and exists as needles, m.p. 77-78°C, b.p. 259°. This chloride with alkaline hydrogen peroxide gives the sodium salt of diperterephthalic acid.

**Chloroterephthalic Acids.**—Because of the ease with which terephthalic acid is converted to hexachlorobenzene by direct chlorination, monochloro-, dichloro-, and tetrachloro-terephthalic acids are best prepared by oxidation of the corresponding chlorinated xylenes or from the aminoterephthalic acids by the Sandmeyer reaction. Melting-points of known chloroterephthalic acids are as follows: monochloro-, 300°; 2:5-dichloro-, 306°-306.5°C; tetrachloro-, 279-281°. Other halogen derivatives known are: 2-iodo-, m.p. 274-276°; 2-bromo-, m.p. 301-303°; 2:5-dibromo-, m.p. 316-317°; tetrabromo-, m.p. about 300°; and tetraiodo-, m.p. 315-320°.

**Nitroterephthalic Acids.**—Nitration of terephthalic acids with a mixture of nitric and sulphuric acids gives nitroterephthalic acid, m.p. 262-263°, which has also been obtained by the oxidation of nitro-*o*-xylene. Treatment of this nitro-acid with fuming nitric and fuming sulphuric acids at 180-190° yields 2:6-dinitroterephthalic acid, m.p. 255°. Oxidation of the

appropriate dinitro-*o*-xylenes has given 2:3-dinitroterephthalic acid, m.p. about 290°, and the 2:5-dinitroterephthalic acid, m.p. about 280°.

**Sulphoterephthalic Acid.**—Fuming sulphuric acid at 250-260° in a sealed tube gives sulphoterephthalic acid, a hygroscopic solid.

**Terephthalaldehyde**, m.p. 116°, b.p. 245-248°, can be prepared by either of the methods described under isophthalaldehyde. It is soluble in chloroform and is reprecipitated unchanged from the resulting solution. It can be sublimed, but is not very volatile in steam.

J. W. B.

**PHTHALOCYANINES.** The dehydration products of the diamides of *o*-phthalic acids combine, in many cases very readily, with metals and salts of metals, to yield a series of highly coloured blue to green tetrabenzotetraaza-porphyrins which have been named the Phthalocyanines.

PREPARATION.

1. The most general method by which these substances may be obtained is by the interaction of a metal or metal salt with aromatic *o*-dinitriles (Linstead and Lowe, J.C.S. 1934, 1022; cf. Diesbach and Van der Weid, Helv. Chim. Acta, 1927, 10, 886). It is usually sufficient to heat the reactants together, although the use of diluents, e.g., tertiary bases or acid amines, is sometimes useful. Alkaline "promoters," e.g., sodium hydroxide, can sometimes be incorporated with advantage (B.P. 538957). For a bivalent metal, R, the reaction takes the following course:

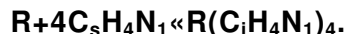

If the metal is in the combined state, the ease of reaction appears to depend upon the facility with which free metal becomes available. Thus, cuprous chloride and phthalonitrile below 200° give copper phthalocyanine and cupric chloride, but cupric chloride, on the other hand, reacts only above 200° when nuclear chlorination occurs to give copper 4-monochlorophthalocyanine.

A somewhat analogous method for preparing copper phthalocyanines, which presumably leads to the formation of the *o*-dinitriles *in situ*, depends on the interaction, of aromatic acid mononitriles or amides containing an *o*-chloro or *o*-bromo substituent with cuprous cyanide (Barrett, Dent, and Linstead, J.C.S. 1936, 1725). Improved yields are obtained by incorporating metallic copper in this reaction (B.P. 498831). Similarly, copper phthalocyanines can be prepared by heating aromatic *o*-dichloro, or *o*-chlorobromo compounds, with cuprous cyanide in the presence of organic nitrogenous bases (B.P. 490744, 490746).

2. *o*-Cyanobenzamide combines with many metals in the free or combined state at temperature of about 250° to yield metallic phthalocyanines (Byrne, Linstead, and Lowe, J.C.S. 1934, 1017). Whether the elimination of water in this case accompanies or precedes the fixation of metals is not understood, although it seems

more likely to be the former, for whereas phthalonitrile and metallic antimony lead to the formation of antimony\* phthalocyanine, when metallic antimony and *o*-cyanobenzamide are heated together the product is metal-free phthalocyanine. The reaction between *o*-cyanobenzamide and magnesium proceeds particularly rapidly.

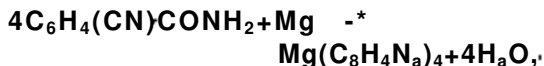

In general, however, the reaction between *o*-cyanobenzamide and metals and metal salts gives a lower yield of the phthalocyanine than when phthalonitrile is used.

3. Some phthalocyanines, *e.g.*, magnesium, copper, nickel, and iron phthalocyanines, are formed when ammonia is passed into a mixture of molten phthalimide and the metal. It was a chance observation of the formation of the iron compound by this reaction which led to the investigation of the group (*see* Linstead, *ibid.* 1934, 1016; B.P. 322169). By this method the conversion to the metal phthalocyanines is very poor and a somewhat analogous though much superior method is in the use of *o*-dicarboxylic acids or their anhydrides, amides or imides, with a suitable metal or metal salt and urea (B.P. 464126) or aminosulphonic acid (B.P. 457786), dicyandiamide (B.P. 503029) or toluene *p*-sulphonamide. The efficiency of the "urea" method can be still further improved by using catalysts, *e.g.*, boric acid and substances containing the elements of the Vb. or VIth groups of the periodic table, *e.g.*, ammonium molybdate (B.P. 476243). Iminophthalimidine is an intermediate product in this reaction.

4. Metallic phthalocyanines, sometimes not obtainable in other ways, are prepared by the double decomposition of dilithium phthalocyanine and metallic salts. When cold absolute alcoholic solutions of the metal salt and dilithium phthalocyanine are mixed, the required metal phthalocyanine is formed immediately by double decomposition and is precipitated (Barrett, Frye, and Linstead, J.G.S. 1938, 1158). Silver and mercury phthalocyanines are among those made conveniently only by this method.

5. Metal phthalocyanines can be obtained in many cases by treating the metal-free compounds with the appropriate metal or metal salt in a high-boiling organic solvent.

Phthalocyanine itself is obtained by the elimination of the metals from the labile metal phthalocyanines (*see below*) by treatment with, *e.g.*, strong or dilute mineral acids (Byrne, Linstead, and Lowe, *ibid.* 1934, 1020). Another method is by heating phthalonitrile with a variety of organic substances, *e.g.*, acids amides (B.P. 457526), triethanolamine (B.P. 460549), or phenols, naphthols or aliphatic hydroxy compounds (B.P. 696334). In all these cases, the two atoms of hydrogen required for the formation of phthalocyanine are supplied by the gross decomposition of the added substances.

By one or other of the above methods, metal phthalocyanines representing every group in the periodic table and including univalent, bivalent, and trivalent metals, have been synthesised.

Group I. Sodium. Potassium. Lithium. Copper. Silver	Group II. Beryllium. Magnesium. Calcium. Zinc. Cadmium. Barium. Mercury.	Group III. Aluminium.	Group IV. Tin. Lead.
Group V. Vanadium. Antimony.	Group VI. Chromium. Molybdenum.	Group VII. Manganese.	Group VIII. Iron. Cobalt. Nickel. Platinum. Palladium.

### Substituted Phthalocyanines.

A very great number of nuclear-substituted phthalocyanines have been synthesised from appropriately substituted phthalic acids or phthalonitriles by utilising one or other of the general methods outlined above. Phthalocyanines containing halogeno, nitro, sulpho, aryl, alkyl, alkoxy, aryloxy, and anthraquinonyl substituents may be quoted by way of example. The effect of substitution on the shade is invariably to produce a shift towards the green. Other methods of preparing nuclear-substituted phthalocyanines are by (a) direct halogenation, sulphonation, etc. (but not, however, nitration which leads to gross decomposition of the molecule), and (b) by replacement of some of the chloro or bromo substituents in the halogenated phthalocyanine by other groups, *e.g.*, aryloxy (B.P. 469139), aryl, and alkylamino (B.P. 471435). Halogenation is readily brought about by treating phthalocyanines with the halogen or a halogenating agent, such as sulphuryl chloride at elevated temperatures, and it is possible, *e.g.*, by chlorinating in hot molten phthalic anhydride or in molten sodium aluminium chloride, to introduce 15-16 atoms of chlorine (Barrett, Bradbrook, Dent, and Linstead, J.G.S. 1939, 1824; B.P. 478256; U.S.P. 2247725). This process brings about a considerable deepening in shade and copper hexadecachlorophthalocyanine is a brilliant green colour. Sulphonation of phthalocyanine and of the stable metal derivatives to give water-soluble products is readily carried out by heating with about 20% oleum. The shade of the parent phthalocyanine is not changed appreciably by this process.

### Analogous Compounds.

The synthesis of analogues of phthalocyanines in which the four benzo rings are replaced by heterocyclic ring systems is possible in certain cases, and the necessary structural conditions have been defined (Linstead, Noble, and Wright, J.G.S. 1937, 911; Bilton and Linstead, *ibid.* 1937, 922). Phthalocyanine bears a remarkable structural relationship with the important natural pigments of the porphyrin series. In the porphyrins the links between the four pyrrole rings are methine ( $-\text{C}=\text{H}-$ ); in phthalocyanines they are nitrogen (*see* formula). Recent work by Linstead and by Helberger and their collaborators has shown that substances of an intermediate type can be realised in which some of the links are methine and some are nitrogen, *see* Linstead, Ghem. Soc. Annual Rep. 1937, 84, 369 for a summary.

PROPERTIES.

Phthalocyanine itself is a slightly greenish-blue solid with a purple reflex. The metallic compounds mentioned above have generally a similar reflex and vary in shade from pure bright blue to green. They are insoluble in water and vary from complete insolubility to moderate solubility in solvents such as boiling chloronaphthalene or quinoline. Some of the phthalocyanines are remarkably resistant to heat and sublime readily *in vacuo* at temperatures up to 600°. Without decomposition; the sublimation is preferably carried out in an inert gas at low pressure. The phthalocyanines of the alkaline and alkaline-earth metals, however, do not sublime. The phthalocyanines also exhibit an unusual stability against attack by most chemical reagents. They are, however, decomposed by acid oxidising agents (*see below*) and certain of the metal derivatives, the so-called labile metal phthalocyanines, readily lose their metal when treated with, *e.g.*, strong or dilute acids. These are the phthalocyanines of trivalent alkaline and alkaline-earth metals and also those like lead and manganese the atomic radii of which are appreciably larger or smaller than 1.35 Å. (The radii of the central space in the phthalocyanine molecule).

USES.

The high general stability of the phthalocyanines to heat, acids, alkalis, etc., makes them especially valuable for use as pigments. When efficiently dispersed, such as by dissolving in a strong acid (sulphuric acid), and reprecipitation by suddenly drowning the solution in water (*cf.* U.S.P. 213693; B.P. 547\*11), the phthalocyanines show high tinctorial strength and brightness combined in many cases with a high stability to light, acids, and alkalis. When efficiently dispersed, copper phthalocyanine (*"Monastral Fast Blue E"*) has twice the tinctorial strength of Prussian Blue and 20-30 times that of Ultramarine. Phthalocyanine itself (*"Monastral Fast Blue G"*) and highly chlorinated copper phthalocyanine (*"Monastral Fast Green O"*) have also found technical use as pigments. They are used in printing inks (*"Monastral Fast Blue B"* being particularly valuable as the minus red in three colour printing work), for paints, varnishes, and enamels, for plastics, paper, colouring viscose in the mass, etc. Various sulphonated copper phthalocyanines also find technical use. According to the degree of sulphonation the products are valuable as lake colours (*"Monosol Fast Blue 208"*), direct cotton dyestuffs (*"Durazol Fast Blue SOS"*) or for dyeing and surface colouring of paper (*"Durazol Fast Paper Blue 1008"*). The salts of the sulphonated phthalocyanines with organic bases (B.P. 460147), with long-chain alkyl ammonium sulphonium or phosphonium bases (Swiss P. 807052) are useful as spirit soluble dyestuffs. Other phthalocyanines designed for dyeing textile fibres are those containing vat-dyeable groups (B.P. 490017), or ammonium or sulphonium groups (B.P. 522293; 525237). The thiocyanophthalocyanines, the mercaptophthalocyanines and they: corresponding disulphides are

useful for dyeing cotton by the sulphur dyeing technique (B.P. 541146; 544953).

STRUCTURE.

Analysis shows that the known phthalocyanines are of the type



where R is a normally bivalent and R' a univalent atom. The assumption that the molecule is of the simplest type, and contains only 1 atom of metal (R), has been justified experimentally by the ebullioscopic determinations of the molecular weight of magnesium phthalocyanine (Linstead and Lowe, J.G.S. 1934,1051), and conclusively proved by the X-ray measurements of J. M. Robertson (for summaries, *see* Ghem. Soo. Ann. Reports, 1936, 88, 160, 214, 221). The reagents which yield phthalocyanine with phthalonitrile give no similar products with terephthalonitrile, homophthalonitrile, o-xylylene dicyanide, o-cyanocinnamitrile and 2:2'-diphenonitrile. Hence it appears that the two nitrile groups participating in the formation of the complex must be linked to adjacent carbon atoms of an aromatic nucleus. Phthalocyanines are decomposed by hot nitric acid, cold acid permanganates or ceric sulphate into phthalimide and salts of ammonia, the fundamental reaction being of the type:

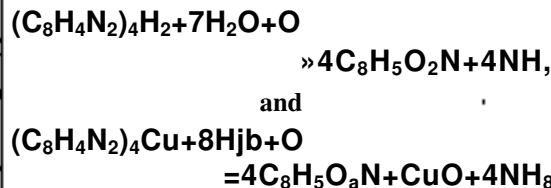

The oxidation with ceric sulphate provides a quantitative method for the estimation of phthalocyanines and it was evidence provided by this method that, with other evidence for which the original literature should be consulted, led to the proposal of the following formula for phthalocyanine (Dent, Linstead, and Lowe, J.C.S. 1934,1035).

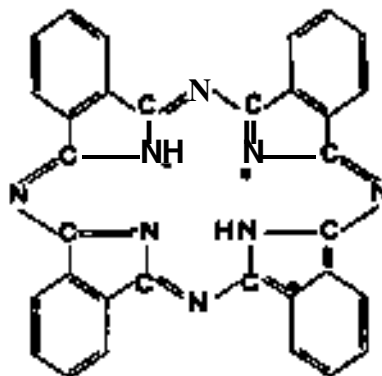

In the metallic derivatives, the metal takes the place of the two hydrogen atoms carried by the two indole nitrogens, and is co-ordinated with the other two indole nitrogen atoms to form chelate rings. The molecule, however, provides a perfect example of resonance and there is no actual distinction between the four indole nitrogen atoms which hold the metal or hydrogen atoms. A complete proof of this structure has

been furnished by the X-ray contour diagrams of phthalocyanines showing the electron distribution in the molecule (Robertson, *ibid.* 1936, 1195).

The peculiar nature of the great ring is also shown by the magnetic anisotropy of phthalocyanine which is 15 times as great as that of benzene (Lonsdale, Proc. Roy. Soc. 1937, A, 159, 149).

The X-ray measurements also show that the four nitrogen atoms and the attached metal atoms lie in one plane and that, in the case of metal-free phthalocyanine, the planarity over the whole molecule does not vary more than a few hundredths of an Angström unit.

With regard to the nature of the primary valencies holding the metal to nitrogen, these differ according to the type of metal involved. The phthalocyanines of the alkali and alkali-earth metals, which are non-volatile, insoluble in organic solvents and which lose their metal when treated with acids, are true salts and thus have their metals bound to nitrogen by electrovalent linkages. Those which sublime and are soluble in organic solvents are the phthalocyanines which contain metals attached to nitrogen by means of co-valent linkages (Barrett, Dent, and Linstead, J.C.S. 1936, 1719).

#### General.

The phthalocyanines as a class present the following features of special chemical interest:

1. Their resemblance in structure to the porphyrins which are the basis of the most important natural pigments such as those of the blood (haemin) and of green leaves (chlorophyll). Previously the peculiar structural arrangement of these molecules was without parallel.
2. The stereochemistry of the metals in the metallic compounds presents many features of interest.
3. In respect of the formation of phthalocyanine, phthalonitrile behaves as a pseudo acid with the property of being able to dissolve (and combine with) metals without liberation of hydrogen.
4. About thirty-nine of the metallic phthalocyanines have been found to be effective as catalysts in certain oxidation reactions. Iron phthalocyanine is generally outstanding. Examples are provided by the oxidation of benzaldehyde to benzoic acid with air and iron phthalocyanine, diphenylmethane to benzophenone (Cook, *ibid.* 1938, 1761, 1768), and the chemiluminescent oxidation of the Luminals.

N. H. H. and B. P. L.

**PICROROCCELLIN**, a colourless, crystalline bitter substance, was isolated by Stenhouse and Groves (Annalen, 1877, 185, 14) from *Roccella fueiformis*. Forster and Saville (J.G.S. 1922, 121, 816) find that picrorocellin has the composition  $C_{80}H_{58}O_4N_4$ , and melts between  $190^\circ$  and  $220^\circ$  according to the rate of heating. By the action of aqueous sodium hydroxide, or at the melting-point, anhydropicrocellin,  $C_{20}H_{10}O_3N_4$ , m.p.  $155^\circ$ , is produced, and this by longer heating passes to xanthorocellin,  $C_{10}H_{16}O_3N_4$ , m.p.  $184^\circ$ . These reactions involve the successive loss of water and methyl alcohol.

Xanthorocellin, when oxidised with nitric acid, yields benzaldehyde, benzoin and *p*-nitrobenzoic acids, together with a sparingly soluble, colourless substance,  $C_{10}H_{14}O_4N_2$ , which at  $300^\circ$  sublimes with some decomposition. It is apparently the 2:3:5:6-tetraketo-1-methylpiperazine previously described by Dubsy (Ber. 1916, 49, 1039; 1919, 52 [B], 216). Methylxanthorocellin, m.p.  $143^\circ$ , oxidised in a similar manner, yields a compound,  $C_{11}H_{16}O_4N_2$ , evidently 2:3:5:6-tetraketo-1:4-dimethylpiperazine. Methylxanthorocellin is thus 2:5-diketo-3:6-dibenzylidene-1:4-dimethylpiperazine, and this conclusion has been confirmed by synthesis. Xanthorocellin is accordingly 2:5-diketo-3:6-dibenzylidene-1-methylpiperazine.

In picrorocellin itself:



the position (1 or 4) of the N-methyl group is uncertain,\* but in all other respects the formula given explains the behaviour of the substance and its conversion into anhydropicrocellin:

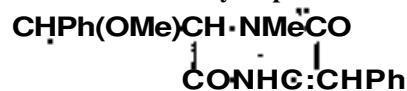

at the melting-point.

E. J. C.

**PICROTOXIN**. A bitter, poisonous, crystalline constituent of *Cocculus indicus* (also known as the Levant nut) which is the small berry-like fruit of *Anamirta paniculata* (Colebrooks), a climbing shrub of Eastern India and the Malayan Islands. It is used as a drug in India, the physiological reaction being similar to that of strychnine and allied neurophilio drugs, and its power of stupefying fish is well-known.

The pericarp of the small black fruit contains no picrotoxin; it occurs in the seeds to the extent of 0.4-1.0% and was discovered in 1812 by Boullay (J. Pharm. Chim. 1812, [i], 4, 5).

Picrotoxin may be extracted according to the method of Barth (J. pr. Chem. 1864, [i], 91, 155; J.C.S. 1863, 16, 586) and Barth and Kretschy (Monatsh. 1880, 1, 98). The crushed seeds are extracted with alcohol, the liquors evaporated and the fatty residue boiled with water, or the seeds may be extracted directly with hot water. The hot aqueous solution is treated with a solution of lead acetate, filtered, excess lead removed by hydrogen sulphide and concentrated. Impure picrotoxin crystallises out, and is purified by recrystallisations from water or alcohol giving rhombic prisms, m.p.  $198-200^\circ$ , very soluble in hot water, alcohol, and benzene and sparingly so in ether and chloroform (see also Meyer and Brugger, Ber. 1898, 31, 2958). A method of extraction using alcohol as the solvent, obviating the use of lead acetate and claimed as superior to previous methods, is described by Clark (J. Amer. Chem. Soc. 1935, 57, 1111).

Picrotoxin is a molecular compound of the two dilactones *drotocinin*,  $C_{16}H_{16}O_6$  (approximately 60%) and *picrotin*,  $C_{15}H_{18}O_7$  (approximately 40%); Bakunin and Giordani (Bend.



Aocad. Sci. Fis. Art. Napoli, 1924, [iii], 30, ^166) who give references to the earlier views of the nature of the complex.

Addition of bromine water to a hot aqueous solution of picrotoxin precipitates monobromopicrotoxin, needles, m.p. 259-260°. Evaporation of the filtrate gives picrotin, purified by repeated extraction with small amounts of hot chloroform and recrystallisation from water (Meyer and Bruger Ber. 1898, 31, 2958), as small felted needles, m.p. 248-250°, readily soluble in absolute alcohol, and acetic acid, but sparingly so in ether, chloroform, and benzene.

Picrotoxin is obtained by reduction of monobromopicrotoxin with zinc and acetic acid, as rhombic prisms,  $C_{18}H_{18}O_4$ , which become anhydrous at 100° and melt at 200-201°. It is readily soluble in hot water, benzene, alcohol, ether, and chloroform.

Picrotin and picrotoxin are very bitter, but only the latter is toxic (Ghristoni, Arch. farm. sperim. 1933, 12, 385).

When subjected to the action of boiling hydriodic acid and red phosphorus (Angelico, Gazzetta, 1911, n. 41, 337) picrotoxin and picrotin give rise to *picrotic acid*,  $C_{18}H_{18}O_4$  (Cetfaloro, *ibid.* 1891, n. 21, 213) and a ketone,  $C_{18}H_{16}O_8$ , called *picrotone* by Mercer and Robertson (J.C.S. 1936, 288), thus indicating the possibility of the same carbon skeleton in both dilactones. This conclusion is supported by the formation of the same chloroketone,  $C_{14}H_{16}O_3Cl$ , from picrotoxin and picrotin with hydrochloric acid at 180°. (Angelico, Atti B. Accad. Lincei, 1910, [i], 19, 473).

Oxidation of picrotic acid (Angelico, Gazzetta, 1911, n. 41, 337) gives a dibasic acid,  $C_{18}H_{16}O_7$ , apparently identical with an alid,

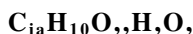

subsequently obtained by the same author (*ibid.* 1912, n. 42, 540) from picrotone and to which was ascribed Structure (I).

By the oxidation of picrotoxin and picrotin, Hansen (Ber. 1933, 66 [B], 850) obtained a phthalic acid,  $C_{18}H_{16}O_7$ , which had the properties of Angelico's acid and gave a monobasic acid,  $C_{18}H_{16}O_8$ , on further degradation. Decarboxylation of the latter yielded *aa*-dimethylphthalide.

Structure (I) was definitely proved for the acid,  $C_{18}H_{16}O_7$ , by Mercer, Robertson, and Cahn (J.C.S. 1935, 997), thus apparently demonstrating the presence of the *aa*-dimethylphthalide residue in picrotic acid.

Picrotic acid contains a side chain,



(Horrnann, Ber. 1916, 49, 2107), but the position of the carboxyl group was not determined. Hydrolytic fission of picrotic acid yields acetone and a dibasic acid,  $C_{15}H_{14}O_4$ , which was considered to retain the side chain (Angelico and Montforte, Gazzetta, 1923, 58, 800). Mercer, Robertson, and Cahn (*I.e.*) have conclusively demonstrated that formula (II) represents picrotic acid.

The constitution of picrotone has been studied by Angelico (*ibid.* 1911, n. 41, 343; 1912, xx,

48, 540), Horrmann and Bischof (Arch. Pharm. 1921, 259, 165). The evidence of these authors taken in conjunction with the constitution of picrotic acid (Mercer, Robertson, and Cahn, *I.e.*), clearly establishes the constitution of picrotone as (III) (Mercer and Robertson, J.C.S. 1936, 288).

Hydration of picrotin, Horrmann (Annalen, 1916, 411, 273) gives *a*-picrotinic acid,  $C_{18}H_{18}O_8$ . Boiling the latter with 25% sulphuric acid (Angelico, Gazzetta, 1910, I, 40, 391) produces an  $\alpha$ -ketol,  $C_{14}H_{16}O_4$ , *picrotonol* (Mercer and Robertson, *I.e.*). Oxidation of picrotonol (Horrmann and Hagendorn, Arch. Pharm. 1921, 259, 7; Mercer and Robertson, *I.e.*) gives an acid,  $C_{13}H_{14}O_4$ , which on decarboxylation yields the tetramethylphthalide (IV) identical with a specimen derived from picrotone.

Fission of the acid,  $C_{13}H_{14}O_4$ , with 60% potassium hydroxide produces acetone and a dibasic acid,  $C_{10}H_{10}O_4$ , identified as 6-methylhomophthalic acid. The structure of the acid,  $C_{18}H_{14}O_4$ , is thus (V) and that of picrotonol (VI).

Picrotoxin, and picrotoxic acid,  $C_{18}H_{18}O_8$ , a monohydration product, contain one double bond. Horrmann and his collaborators (Ber. 1916, 49, 1554; Arch. Pharm. 1920, 258, 200) maintained that ozonolysis of picrotoxin and picrotoxic acid produced only *picrotoxinone*,  $C_{18}H_{16}O_8$ , and *picrotoxinonic acid*,  $C_{18}H_{16}O_9$ , respectively, plus formic acid.

Mercer and Robertson (*I.e.*) have identified formaldehyde as a product of ozonolysis thus indicating that the double bond is present as a vinyl group. This double bond is not concerned in the conversion of picrotoxin into picrotoxic acid (Horrmann *et al.*, Ber. 1916, 49, 1554; Arch. Pharm. 1920, 258, 200; Mercer and Robertson, *I.e.*).

As a means of locating the double bond, picrotoxinone was converted into an aromatic system (Harland and Robertson, J.C.S. 1939, 937) analogous to the formation of picrotinic acid from picrotoxin. Reduction of the carbonyl group of picrotoxinone, with boiling hydriodic acid and phosphorus, yields a phenolic ketone,  $C_{13}H_{18}O_6$ , m.p. 189°; *norpicrotic acid*,  $C_{14}H_{16}O_4$ , m.p. 113°; and *hydroxynorpicrotic acid*,  $C_{14}H_{16}O_6$ , m.p. 213°. Reduction of the phenolic ketone produces a phenol,  $C_{18}H_{18}O$ , m.p. 66°, identified by synthesis as 1-methyl-4-ethyl-5:6:7-trimethyl-3-naphthol (VII).

Picrotoxin is probably related to the sesquiterpenes of the cadinene group, and contains the same carbon skeleton (Mercer and Robertson, *I.e.*; Harland and Robertson, J.C.S. 1939, 937). On this assumption, *picrotoxinin* is represented by the partial formula (VIII) and the position of the double bond is fixed as shown.

Thus the lactone ring system which appears in the *aa*-dimethylphthalide fragment of picrotone, picrotonol, and picrotoxic acid is an artefact arising by the hydration of the isopropylidene residue with subsequent lactonisation. *ffor*-*vicrotic acid* is represented as (IX), and *hydroxynorpicrotic acid* as (X), and, in agreement with these structures, fission with potassium hydroxide does not produce acetone.

PICROTOXIN.

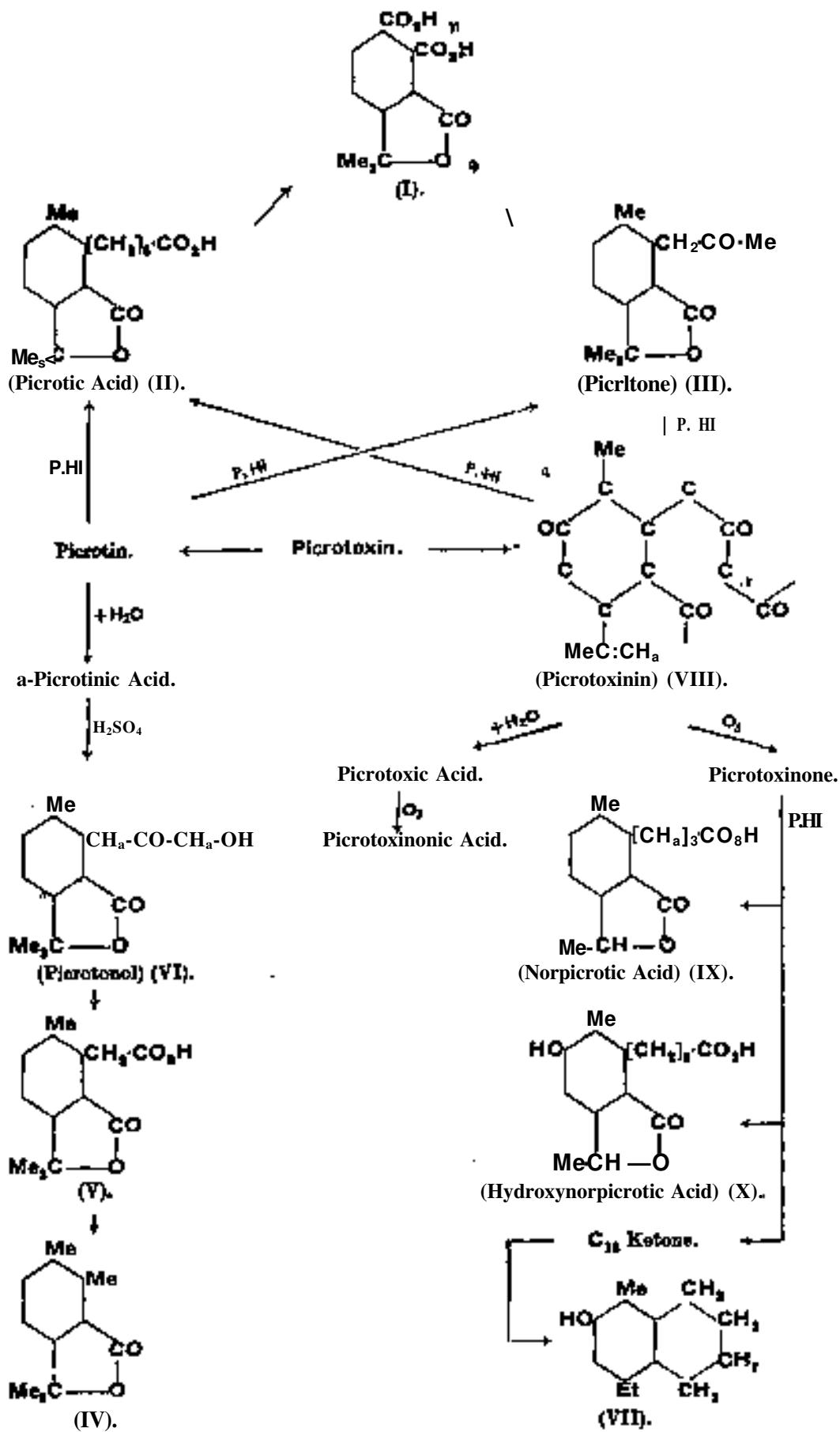

a-Picrotoxinic acid also has an ethynic linkage present in an isopropylidene system, since on ozonolysis it yields a product which on being foiled with hydriodic acid and phosphorus gives rise to the ketone,  $C_{14}H_{16}O_2$ , and nor-anthrahydroxynor-picrotoxinic acid (O'Donnell, Robertson, and Harland, *ibid.* 1939, 1261).

The hydrogenation of picrotoxin also has been studied intensively by these authors (*i.e.*) as they were unable to confirm the result\* of the work of Mercer and Robertson (J.C.). Picrotoxin is readily hydrogenated, using a platinum catalyst, to a-dihydropicrotoxin (Mercer and Robertson, *i.e.*; Tetweiler and Drishaus, *Annalen*, 1935, 520, 163). Warming this hydrogenated picrotoxin with 5% sulphuric acid causes quantitative conversion to dihydropicrotoxinic acid, identical with a specimen prepared from picrotoxin added in glacial acetic acid using a palladium catalyst. The reduction of picrotoxin in ethyl acetate solution with a palladium catalyst may give exclusively  $\beta$ -dihydropicrotoxin, which has not been hydrated, or a mixture probably containing  $\alpha$ - and  $\beta$ -dihydropicrotoxin and a neutral compound, which produces picrotonol on boiling with dilute sulphuric acid.

Reduction of picrotoxin with a palladium catalyst in alcohol containing a little hydrochloric acid gives a mixture of at least three compounds (Mercer and Robertson, J.C.S. 1936, 288). Treatment of this mixture with dilute sulphuric acid gives dihydropicrotoxinic acid and picrotonol—the first recorded production of the latter from picrotoxin.

W. B. W.

PIGMENTS AND LAKES. (Latin *Pigmentum* from *pingere*, to paint.);

#### HISTORY.

The use of pigments can be traced back to remote antiquity, even to palaeolithic times. Thousands of years before the Christian era, the ancient Egyptians excelled in pictorial art. In Assyria, in Lydia, from the eighth century B.C., and by the Ionians and Phoenicians, from about the sixth century B.C. painting was skillfully practised, and held in high esteem. Cimex of Cleonee, his successors Polygnotus of Thasos (463 B.C.), Apelles of Colophon, and Zeuxis of Heraclea, and other early painters worked chiefly in fresco and tempera, with a limited range of pigments, nearly all mineral. Encaustic was not commonly practised until after the time of Alexander the Great. The pigments were mostly the ochres, red lead, cinnabar, orpiment, chalk, gypsum, lapis lazuli (?), indigo, carbon, and certain special colours, such as "Egyptian blue" (a copper frit or glass) and "Tyrian purple." From the accounts given by Pliny the Elder and Theophrastus, it would appear that a blue prepared from lapis lazuli was not known in classical times. Red lead, or minium, was used for the coloured statue of Jupiter, set up by King Tarquinius Priscus in the Roman Capitol. The vegetable colours anciently used have probably for the most part decayed, leaving no traces; but a pink madder lake and a yellow lake have been discovered among the pigments of the ancient Egyptians.

#### DEFINITIONS.

A Pigment may be defined as a solid, usually in powder form, which, when dispersed in a medium in which it is substantially insoluble, confers on the mixture a pronounced hue or colour (white and black being regarded as colours). In general, though by no means essential, it is desirable that pigments be opaque, in order to obliterate the original colour of the matrix or surface.

Stainers are pigments which are relatively transparent, and which are generally employed when it is desired to retain the original characteristics of the surface, *e.g.*, the grain of oak and other hardwoods.

Extenders are materials notably deficient in both colour and opacity, but possessing other useful properties. They are employed to reinforce the mechanical or rheological properties, or to modify the surface characteristics or finish produced by the composition. Thus the suspension of pigments, the production of matt finishes or improvement of brushing characteristics may be achieved by the incorporation of suitable extenders. When used in large amount the object is usually to cheapen the product.

Lakes may be described as soluble dyestuffs or colouring matters, which have been rendered insoluble in water by treatment with suitable precipitating agents, and precipitated on a base or sub-stratum. Lakes were originally made from naturally occurring dyestuffs, *e.g.*, Madder root, Cochineal insects, Persian Berries, etc., and were prized for their brightness of hue, although most of these lakes were relatively fugitive in sunlight. With the increase in the variety of synthetic dyestuffs available, and the multiplicity of methods of preparing pigments therefrom, any sharp distinction between lakes and pigment dyestuffs is of small moment, and these will therefore be treated under the general heading of pigments of organic origin\*. It should be noted that Dyes and Stains are soluble and are used in solution whereas pigments and lakes are insoluble and are used in suspension.

#### USES AND PROPERTIES.

The ever-increasing demand for colour and the development of technique in the production and application of colour has resulted in many of the articles of commerce, formerly available only in black (*e.g.*, saucepans, gratings, etc.) or in natural colours (*e.g.*, leather, rubber, etc.) requiring to be finished in bright and attractive colours. Thus the manufacture of pigments, once associated exclusively with paints and painting, is now quite a separate and distinct industry, catering for many other users, *e.g.*, plastics, rubber, leather, ceramics, enamelled hollowware, glass, cements, paper, printing inks, fabrics, etc.

The selection of a pigment is not merely a matter of choosing the right colour. The matching of a red fabric (curtain, carpet, or dress) may necessitate the use of quite different pigments according to whether the use is to be for plastics (requiring resistance to heat), paint (insolubility in oils), rubber (liability to perishing), or paper (effect of inks), etc. Even among

paints the different requirements of air-drying paints, stoving synthetics, cellulose lacquers, and oil-bound distempers may call for quite different pigments to attain similar colour effects. Thus it is often necessary to compromise on less essential features (brightness of colour) in order to ensure the essentials (fastness to light or heat, etc.) and the selection of the most suitable pigment for any purpose becomes a question for the competent technical expert. Before enumerating the properties of pigments in detail, it is desirable to have a clear idea of the properties required for any specific use.

**Pigments in General.**—Pigments should be insoluble in the medium in which they are used and unaffected by it; as durable and fast to light as possible, inert and unaffected by the other components of the mixture; and easily wetted and incorporated in a mixture and not liable to separate on standing. As far as possible they should be non-corrosive and non-toxic, so that articles coming in contact with them (food, clothes) are not likely to become contaminated.

**Pigments for Special Purposes.**—There are, however, cases where precisely the opposite requirements may hold. Anti-corrosion pigments mostly act by virtue of a passivating action on iron or steel; anti-fouling pigments are toxic to marine organisms and may contain copper, mercury, or arsenic. Luminous, or fluorescent pigments, as well as temperature-indicating pigments, are necessarily chemically unstable and require careful handling. Some contain radioactive materials and should only be used under competent supervision.

For plastics, heat resistance and compatibility with phenols and formaldehyde are essential. In the case of rubber, ability to withstand processing and vulcanisation is necessary, whilst the presence of traces of copper or manganese must be rigidly excluded as these accelerate the oxidation of rubber and cause perishing. In the case of ceramics, enamelled hollow-ware, and glass body pigments are actually fused in a frit or melt and undoubtedly undergo partial solution and chemical reactions during application, so that the range available is strictly limited. The gold lines on china cups and saucers are often pure metallic gold applied in the form of a gold sol and fired on to the porcelain surface. In the case of cellulose lacquers and certain synthetic resins, the powerful solvents used would attack many pigments commonly used in oil paints, and selected pigments insoluble in these solvents are required, whereas in the case of stoving finishes, heat resistance is important. For printing inks very fine graduations in top and undertones, extreme fineness, and fastness to light are matters of extreme importance.

**Classification.**—Chemical composition is not a fundamental factor. Old classifications based thereon are not satisfactory. Classification based on colour would be more acceptable, but for the fact that a range of colour is available in most groups of pigments by simple variations of treatment. The method adopted in this article, therefore, is that of treating like pigments in groups, following as far as possible in the order white, yellow, brown, red, blue, green, black, and metallic.

Pigments may be further classified as to origin and method of preparation:

*Naturally occurring.* Mostly mineral pigments, e.g., iron oxides, ochres, vandyk brown, mineral black, ilmenite, and most of the extenders.

*Chemically prepared.* E.g., white lead, zinc oxide, lithopone, lead and zinc chromes, Prussian and ultramarine blue, lakes and pigment dyes+offs.

The production of zinc oxide, white lead and many other items are the subject of separate articles. Details of preparation will be limited to what is material to the preparation of satisfactory pigments.

Considerable confusion exists in respect of terminology so that a limited number of definitions may be stated:

**Hue** is that physical property of pigments which connotes the species of colour reflected: e.g., red, blue, green.

**Shade** should properly be reserved to specify the dullness or greyness of a colour, i.e., the opposite of brightness.

**Tint** is the effect produced by the admixture of white with a pigment; thus sky blue, eau de nil, stone etc., are tints.

**Tone** is a subsidiary colour effect which becomes evident when a pigment is examined in thin films or as a tint. Thus some reds possess a blue tone, i.e., they produce a series of tints becoming progressively bluer as more and more white is added, whereas other reds may become progressively more yellow or scarlet. Mass tone, overtone, and undertone are further variations in common use. Unfortunately the term *shade* is frequently used instead of tone, thus "red B.S." indicating a red having a blue shade or undertone.

The oil absorption of a pigment is defined as the weight of oil in grams required to convert 100 g. of the pigment into a smooth paste.

The opacity of a pigment is a function of the refractive index of the pigment relative to that of the medium in which it is dispersed. The refractive indices of pigments vary from titanium oxide (2.7) to that of white lead or zinc oxide (about 1.9). Extenders have lower refractive indices, between 1.53 and 1.63. The refractive index of most oils and varnish media is around 1.48-1.50, that of water being 1.33, in comparison with air as unity. The relative opacity of equal volumes of pigments immersed in the same volume of medium, would be proportional to the difference of refractive index of pigment and medium. Fineness of division, however, influences the result by inducing scatter, opacity generally increasing as particle size diminishes, an optimum being reached in the region of particle size  $1/\mu$ . On a weight basis, a low density implies a larger volume of pigment, so that a combination of low density and high refractive index implies a high opacity, which can be modified within limits by fine grinding. With extenders, which are relatively transparent in oil (due to the small difference of refractive index) improved opacity is found in water media,

and whitening is frequently used in distempers as a pigment, though by custom it is trotted throughou^t as an extender. (See *Ulo* refractive index of organic figments, Cooper, J. Oil Col. Chem. i&soc. 1948,31, No. 339.)

The spreading rate or covering power of a punt (the area covered by unit quantity while still affording adequate obliteration) and the relative hiding power (opacity of fijms at equivalent degree of spreading) are obviously closely linked proferties which again depend v.n a\*number of variables (flow, dispersion, etc.) BO that no simple correlation exists.

The staining power or relative strength of a coloured pigment is determined by admixture of s&ndajd white (usually zino oxide) in suitable ratios (between 10:1 and 100:1) so as to obtain tints of equal depth in «il, when the strengths are in the inve/se ratio. Whites are similarly tested, using an inverse staining power ratio as determined by the use of carbon black standard tinter (1:100).

**Particle Size.**—The size of prticles of pigments may range between 1 /x. and 60 /<sup>o</sup>. (0.001-0.06 mm.) diameter. Coarse particles of 60-100^t are objectionable, whilst in some special cafes (e.g., carbon«blacks) particles *tia* small as 0.1 ft. may J>e present in appreciable amounts. For comparison it may be pointed out that the average aperture of a 300 mesh (sieve) (300 mesh per linear inch) is 53 /<sup>o</sup>., and that the upper limit of colloidal particles subject to Brownian movement is 0.1 p. The wave-length of green light is about 0\*5 p. and the limit of resolution of the compound microscope using green light is approximately half this, viz. 0.25 p. It will be seen that, the particle size of many pigments is such that it is very near the liniits of resolution of the ordinary microscope, and it is precisely within these liniits that pigments may be expected to develop maximum hiding power. Recent work with the electron microscope (v. Vol. VIII, 842) has indifcated "that extremely useful results are likely to accrue from further investigation in this region (Paint Research Station Technical Pafer No. 138; The Electron Microscope and its application to the study of Pigments).

Little systematic knowledge of the shape is available, and it is in this direction that the electron microscope may be expected to prove valuable. The typical platelet structure of micas and metallic powders, the crystalline structure of the chromes and many extenders, the fibrous structure of asbestine and the gel structure of alumina bases of pigment colours all obviously affect the resultant properties of the pigments, and must be taken into account when correlation of particle size with other properties is under consideration.

PREPARATION OF PIGMENTS.

The methods by which pigments are prepared may be divided roughly under the headings given below.

**Grinding and Levigation.**—Many of the earth pigments and those of mineral origin merely require sorting, washing, and grinding to suitable fineness\*. The mineral as it comes from the mine may need crushing to enable it to be

fed to a disintegrator, edge runner, or ball mill. The grinding may be carried out dry (*i.e.*, air flotation) or wet (*i.e.*, levigation). Air flotation has the great advantage that subsequent drying and regrinding is avoided and a continuous process can be installed whereby the finest particles are removed from the cycle at pre-determined setting (say 300 mesh), the oversize being returned to the mill. Where, however, impurities have first to be washed out (or left behind) this is often achieved by levigation. The mineral is ground under water and the suspension is run to large settling tanks. By varying the rate of flow, fractionation may be effected, the coarsest particles settling in the first tank, the required pigment in the intermediate tanks, and the very finest particles in the last tanks of the series. This procedure is usually adopted where large natural supplies of water are available at negligible cost and the product can be handled on a very large scale, e.g., China clay. When the tank is full the water is diverted to other tanks, and the material allowed to settle, removed, and dried.

**Calcination.**—Many naturally occurring pigments and some manufactured materials are improved in colour or other properties by calcination at high temperature. Ochre, Sienna, and Umber are so treated (being known as Burnt Sienna, etc.) as well as many iron oxides, to enhance the colour, whilst lithopone and titanium oxides are furnaced, to improve opacity. Such pigments usually require grinding afterwards and either wet or dry grinding may be employed acorjrding to circumstances.

**Volatilisation.**—Those pigments which are prepared in the form of a fume, e.g., zinc or antimony oxide, carbon black, etc., are usually collected in chambers or condensers. They are generally very fine (particle size around 1 /<sup>o</sup>.) and seldom require further grinding.

**Corrosion.**—Pigments (notably white lead, verdigris, etc.) produced by corrosion are usually ground wet, washed free from soluble salts and heavy particles, particles of metal, etc., and then filtered, dried, and ground in the ordinary way. White lead is exceptional, in that a water-pulp of white lead is sufficiently hydrophobic to permit pugging with oil, whereby the pigment is preferentially wetted with oil and the water may be run off by decantation. A short milling under vacuum enables an oil paste to be obtained free from water.

**Precipitation.**—The precipitation of pigments by double decomposition (*e.g.*, lead chromes, Prussian blue, and the preparation of lakes and organic pigments by \$ie process of colour striking) leaves the product in the form of a precipitate, suspended in liquors charged with soluble salts. After settling, the clear liquors may be nfli off by decantation, and tfee vat refilled with wtfer. This is known as washing, and after several washes in this way the concentration of soluble salts is sufficiently reduced to permit the resulting Blurry being pumped to filter presses, where the bulk of the •emaining water is removed. The press cake is then usually spread on trays and dried in stoves by means of hot air at a moderate temperature, [n larger installations where a continuous pro-

cess is in operation, the precipitate may be de-watered or concentrated by means of Dorr-Oliver thickeners, and the thickened slurry conveyed to continuous rotary vacuum filterers and thence to driers. The drying may also be done by means of film driers (rotating steam heated drums) or spray drying (sprayed into a large volume of hot air as in the case of dried milk, etc.). Where high temperatures are permissible the wet pulp may be fed direct to a rotary kiln drier (as in the case of titanium oxide) and the drying and calcination conducted in one stage. In the majority of cases, however, relatively low temperatures are essential to avoid discoloration, and drying under vacuum at still lower temperatures may be necessary in some cases.

#### THE WHITE PIGMENTS.

The white pigments which are sufficiently opaque for use in oil media are:

White lead and basic lead sulphate.  
Zinc oxide, zinc sulphide, and lithopone.  
Antimony oxide and tin oxide.  
Titanium oxide and titanium white.

The relatively transparent whites, which are termed extenders are:

Barytes ( $\text{BaSO}_4$ ) and blanc fixe (precipitated).  
Strontium sulphate ( $\text{SrSO}_4$ ).  
Terra alba or gypsum ( $\text{CaSO}_4 \cdot 2\text{H}_2\text{O}$ ).  
Witherite ( $\text{BaCO}_3$ ).  
Whiting, Paris white ( $\text{CaCO}_3$ ).  
Magnesium carbonate ( $\text{MgCO}_3$ ).  
China clay, talc, asbestine, silica, slate powder, etc.

In addition there are a number of bases, prepared by precipitation, for use as a substrata on which to strike dyestuffs, e.g., alumina white, blanc-fixe alumina, alumina phosphate, and satin white.

**White Lead.**—Known variously as Dutch white, cerussa alba, ceruse, Venetian white, Berlin white, Bleiweiss, Krems or Kremnitz white, blanc de plomb, blanc d'argent, silver white or flake white, this well-known pigment has been made for centuries by the corrosion of metallic lead. Until 70 years ago it was manufactured exclusively by the traditional Dutch "stack process," in which cast lead wickets were built up layer upon layer over pots containing weak acetic acid, standing upon waste tannin or other fermentable vegetable refuse. The completed stack took some 3 months to ferment, during which the lead was slowly oxidised, dissolved, and converted via basic acetate into basic carbonate. Such a stack would contain upwards of 120 tons of lead and the technical limitations of the process and the long time required naturally led to many attempts to replace it by a more rapid means capable of proper control. The prejudice in favour of stack lead was but slowly overcome and the newer methods, which may be classified as chamber, quick corrosion, precipitation, and electrolytic, are now well on the way to eliminating stack lead almost completely.

Stack white lead is characterised by a coarse

structure, some particles being as large as  $20 \mu$  in diameter, possessing low oil absorption, and is easily wetted by oil. It is preferred for the manufacture of paste paints and is usually somewhat discoloured by the tannin used. Chamber-process or quick-corrosion lead is whiter, of higher oil-absorption, more bulky, and in a finer state of division, and is commonly used for ready mixed paints, whilst the precipitated white lead has the highest oil absorption and is if anything still whiter. (For further details of the various methods of manufacture, v. Vol. VII, 245 *et seq.*; or N. Heaton, "Outlines of Paint Technology," 3rd ed., Charles Griffin, 1947, pp. 54 *et seq.*)

White lead is a basic carbonate of lead of indefinite composition, generally described as  $2\text{PbCO}_3 \cdot \text{Pb(OH)}_2$ . Whilst the commercial product is kept within narrow limits when made by any one process, the degree of carbonation obtaining in different processes varies considerably. According to the B.S. 230-1935 the composition must lie within the limits of 20-33% hydrate and 67-80% carbonate, corresponding to a carbon dioxide content of 11-13%. These would permit variations between  $3-6\text{PbCO}_3 \cdot \text{Pb(OH)}_2$  and  $1-3\text{PbCO}_3 \cdot \text{Pb(OH)}_2$ . Excessive carbonation reduces the opacity, but insufficient carbonation, whilst improving the opacity, is liable to yield a white lead of high reactivity, causing it to thicken in paints.

The good obliteration power ascribed to white lead is due more to its brushing properties than to its intrinsic opacity. The refractive index is around 1.9 and its density 6.8. Owing to its high density and coarse structure, paints made on white lead have a low spreading rate (about 500 sq. ft. per coat dry white lead) so that excellent obliteration is observed. When tinted with coloured pigments, however, it requires rather less colouring matter than the same weight of zinc oxide, indicating that its opacity is actually inferior to that of zinc oxide.

For exterior paints it is still regarded as the pigment "par excellence." It has sufficient reactivity with oils to enhance the rate of drying and form elastic films, which do not crack. It has adequate covering power, and although it is liable to discoloration in industrial atmospheres charged with sulphurous gases, this is to some extent offset by its liability to chalk on exposure. The film is thus weathered away slowly, exposing fresh surfaces disposing of the discoloration, and leaving the surface in an ideal condition for repainting.

The toxicity of white lead and lead compounds has been a matter of considerable concern in the past and has led to statutory regulations covering both the manufacture and use (v. Lead Poisoning, Vol. VII, 256c). It is, therefore, not used in interior painting, nor should it be sprayed without special precautions. As a result of extensive investigations it has been shown that the chief danger is dust and that by suppressing dust, the incidence of lead poisoning in the manufacture of white lead has been reduced to negligible proportions. Rubbing down of white lead paints should be done wet, using water-proofed sand paper (see also Lead Paint (Protection against Poisoning) Act,

1926). Most of the white lead used in paint manufacture is purchased as oil paste rather than dry. White-lead oil paste is manufactured direct from the water pulp by pugging with oil, whereby the white lead is preferentially wet by the oil and the water is displaced and may be decanted. A short milling under vacuum, suffices to produce an oil paste substantially free from water.

**Basic Lead Sulphate or Sublimed White Lead.**—First patented by Bartlett in 1870, it was originally manufactured in this country in 1882 by roasting high-grade galena concentrates in a modified form of blast-furnace. The volatilised lead sulphide, after oxidation by means of cold air blast, was collected in a cooling chamfer, yielding a product of fairly constant composition:

Lead sulphate . . . . .	71.5-80%
Lead oxide . . . . .	14-20%
Zinc oxide . . . . .	5-8%

It was very little used up to 1908, when Hannay patented improvements, which were successfully operated at Glenford until 1924, when the factor was closed down.

The composition varies between  $5PbSO_4, PbO$  and  $2PbSO_4, PbO$ . It brushes more easily than white lead, spreads further, and in consequence exhibits inferior obliterating power. It was originally claimed to be non-toxic, but although this attitude had to be abandoned it is certainly less dangerous than white lead. It is also less liable to discoloration in industrial atmospheres and does not chalk.

**Pattinson's White.**—Patented by Pattinson in 1849 and abandoned after having been manufactured over a few years, this pigment is of historic interest only. It was prepared by dissolving galena ( $PbS$ ) in hydrochloric acid and precipitating the basic chloride by the addition of one half the equivalent amount of lime water. The composition corresponded with that of the mineral laurionite,  $Pb(OH)_2, PbCl_2$ .

**Antimony Oxide,  $Sb_2O_3$ .**—Antimony oxide is prepared by the volatilisation and oxidation of purified antimony metal. Owing to the fact that the oxide itself is volatile (in contradistinction to zinc oxide) it is essential to cool the vapours rapidly, otherwise a coarse crystalline product is obtained which is useless as a pigment. Prior to 1919 insufficient attention had been paid to this fact and the successful commercial use of the pigment dates from about this time. Being an acidic oxide it is unaffected by acid media and retards chalking of other pigments, e.g., titanium oxide, in paints. It finds considerable use in cellulose lacquers and synthetic finishes for this reason. Its obliterating power is superior to that of zinc oxide. It is easily wetted by oil and its low oil-absorption, together with its high density enables pigment concentrations up to 78% (by weight) to be brushed satisfactorily (Clarke, J. Oil Col. Chem. Assoc. 1921, 4, 2). Its particle size is about 1  $\mu$  (rivalling zinc oxide in this respect) and films containing it do not harden and crack on ageing. It is liable to slight discoloration on exposure in industrial atmospheres. In spite of the poisonous nature of antimony salts, it is

not regarded as dangerous in this respect when used in paintst

**Zinc Oxide.**—Known also as Chinese white, snow white, zinfcweiss, and flowers of zinc, zinc white was first manufactured in France by Courtoise in 1751 by what is now known as the indirect process. Metallic zinc or spelter is volatilised from crucibles heated in a furnace equipped with a suitable hood and exhaust draught. As the metal volatilises, it issues from a hole in the lid and is burnt to form zinc oxide in the form of a dense smoke, which is led to suitable collection units, graded, and bagged. That nearest the furnace is least pure, and the product is usually labelled as white, green, red, yellow, or blue seal—the white seal being the best, usually 99.8% purity. Green and red seals are almost as high purity, but yellow and blue seals are noticeably off-colour.

The *Direct Process* was first installed at Franklin, U.S.A., in 1851 by Wetherill in order to utilise a low-grade ore comprising franklinite, willemite, and zincite, and containing only 20% of zinc. The ore was spread on a layer of anthracite and burnt in the furnace, and the fume, after passing a trap for retaining ash, was collected and condensed in chambers. Owing to the relative absence of volatile impurities a satisfactory zinc oxide is obtained containing up to 5% of lead.

**Continuous Process.**—Of recent years, continuous processes have been developed, based on the use of a rotary reverberatory furnace into which metallic zinc is fed on to a bed of anthracite or coke, the heat of oxidation being sufficient to maintain the temperature once the reaction has been initiated (RP. 391514 and 435005). The slower rate of volatilisation of the continuous process favours the development of coarser particles which are acicular in form. *Acicular zinc oxide* has been shown to have superior durability and is not so liable to cracking of surface coatings made from it (J. Oil Col. Chem. Assoc 1942, 25, 53).

The present consumption for paint purposes of zinc oxide approaches that of white lead. Its non-poisonous character and the exceptional gloss and flow characteristics make it the pigment "par excellence" for light-tinted interior enamels. The addition of small amounts to exterior paints tends to harden the final film, reducing dirt retention\* and improving gloss. Larger amounts are liable to cause cracking or checking, and in this case the acicular type has much to recommend it. For paints, colour and opacity are important, whereas for incorporation in rubber, grades possessing smaller particle size (down to 0.1  $\mu$ .) are preferred, and the mechanical properties are paramount. The opacity of these grades may be poor. Zinc oxide is basic in character and care must be taken to avoid acidic media, otherwise it is liable to set to a gel-like cement.

**Lithopone.**—The introduction of a new pigment in the form of a co-precipitated zinc sulphide-barium sulphate complex in 1874 was due to J. B. Orr. Known as Orr's zinc white and a variety of other names (e.g., phonolith), it has rapidly overcome the early objections advanced against its use, and is today one of



the most extensively used white pigments for interior work. Lithopone is manufactured by the double decomposition of solutions of barium sulphide and zinc sulphate according to the equation:



The reaction is unusual in that both products are insoluble, leaving no soluble salts to be washed away. The whole merit of the invention, however, turns on the subsequent heat treatment of the precipitate at 700°C. in the absence of air, whereby the optical density is enhanced, without which the product has very little value as a pigment. Lithopone possesses a high degree of opacity, is a pure white in colour and can be manufactured at a very competitive price. The world output is of the order of a quarter of a million tons per annum, of which some 40 millions are consumed in this country in the manufacture of paints. Originally it was very liable to photogenic darkening in sunlight or ultra-violet light, as a result of which painted surfaces might darken badly within a few hours of exposure to bright light, but this defect has largely been overcome by methods not fully disclosed (see B.P. 264223 *et al.*). According to Mills (J. Oil Col. Chem. Assn. 1936, 19, 109) any lithopone can be stabilised against actinic action by the addition of 0.015% of cobalt (see B.P. 225523). Lithopone has several marked advantages—high opacity, superior to that of zinc oxide or white lead, non-reactivity with weak acids, so that it can be used with safety in acid varnishes, cellulose lacquers, and synthetic resin media, and relatively low price. On the other hand, the gloss obtained in enamels is much inferior to that of zinc oxide, and its liability to oxidation on exterior exposure leads to early failure both on metal and wood surfaces. Its chief use is therefore for interior undercoats, for matt finishes\* of all types, and in good-grade washable water-paints (oil-bound distempers). Substantial addition of zinc oxide increases its exterior durability (Mills, *I.e.*) and it is extensively so used in the U.S.A. From the equation, the\* theoretical composition of the product is ZnS 29.5, BaSO<sub>4</sub> 70.5%, and lithopone of this type is commercially described as 30% lithopone, the most generally used type. A double-strength quality, known as 60% lithopone, is made by replacing a half molecular equivalent of zinc sulphate<sup>1</sup> with zinc chloride, followed by thorough washing-out of the soluble salts so produced, before furnacing. In Germany, it was the practice to make this quality and to reduce it to the 30% quality, by milling it together with the requisite quantity of natural barytes, so obtaining a product of lower oil absorption. <sup>1</sup>This practice is easily detectable by microscopic examination under polarised light (crossed Nicol prisms) when the crystalline character of the barytes is clearly visible against the black background of true lithopone, which is isotropic under these conditions. Owing to the difficulty of excluding air during the furnacing operation, most lithopones contain traces of zinc oxide (0.3-30% of ZnO), and where it is essential to avoid this, a special quality known as spirit lithopone, which has been washed in weak acetic

acetic acid, to remove the zinc oxide, should be used. It was originally considered that the complex ZnS, BaSO<sub>4</sub> was in the nature of a chemical compound, but this view is\* not upheld by X-ray examination (Wood, J.S.C. 1.1930, 49, 300T). It is more likely due to the development of a denser crypto-crystalline structure. Its<sup>4</sup> refractive index is 1.84 and density 4.3, neither figure being far removed from the arithmetic mean of its components (Mills, *I.e.*). Lithopone is extensively used in the rubber and linoleum industries; a\* full review of its uses is given by Morris (Paint, Oil, and Chem. Rev. 1928, 85, No. 22; 1929, 87, No. 23; 1930, 89, No. 16).

Zinc Sulphide.—It is natural that the successful development of lithopone should lead to attempts to introduce the straight 100% zinc sulphide as a pigment. It was not until 1927, however, that a technically pure zinc sulphide, under the name of "Sactolith" was introduced into this country (see B.P. 250581; B. 1927, 259). Its brilliant white colour and high refractive index (TT<sub>D</sub> 2.37) combined with a relatively low density (4.0) and small particle size (around 1 μ) all combine to yield a pigment of exceptional opacity and high tinting strength, and only to titanium oxide. It is not extensively used in oil paints for exterior purposes for the same reasons as lithopone, but in cellulose lacquers and synthetic stoving finishes it enables coatings of high opacity to be built up using minimum pigment concentrations, and in these special applications it is definitely advantageous.

Titanium Oxide, TiO<sub>2</sub>.—Titanium occurs relatively widespread throughout the earth's crust, but owing to the difficulties of isolating it and to the refractory nature of its\* ores it has remained until quite recently comparatively "rare." Its use as a pigment was first suggested by J. W. Ryland of Birmingham in 1865, who imported ground ilmenite from Egersund, Norway, and patented its use as a black pigment for the manufacture of paint. In 1870, John Overton took out a patent in the U.S.A. for the use of ground rutile (TiO<sub>2</sub>) as a component of anti-fouling compositions for ships hulls. Although Ryland realised that the great opacity of ilmenite was due to its content of titanium dioxide, the idea of separating it in the pure state does not appear to have occurred to him. Between 1908 and 1921 investigations by Jebson and Van-up in Norway, and Rossi and Barton in the U.S.A., resulted in the commercial production of titanium white pigments. Originally these pigments contained considerable amounts of calcium phosphate or barium sulphate, and it was not until 1927 that the pure titanium oxide (98%) was available commercially. The method of manufacture now generally adopted is the treatment of the finely powdered ilmenite (FeTiO<sub>3</sub>) with concentrated sulphuric acid, when the heat of reaction is sufficient to convert the mass into a paste of mixed sulphates of titanium and iron. These are dissolved in water, and the solution filtered from any residue, diluted, and heated, when the hydrated titanium dioxide resulting from hydrolysis is precipitated, whereas the ferrous sulphate remains in solution. Hydrolysis is facilitated by seeding with hydrated\* oxide from the

previous batch, or More generally by running the material forward on a continuous process so that continuous precipitation and thickening occurs, the thickened slurry being pumped to filters and removed from the cycle. The refractive index of this product is only 1.8, whereas, by fumacing, it can be raised to that of the crystalline oxide, 2.7. Fumacing is carried out in rotary furnaces under careful control. The crypto-crystalline condition is necessary to obtain maximum opacity, but overheating results in coarse particles of hardness about 7 (Moh's scale) and such material will abrade Steel (hardness=6J) so that when rubbed out with steel palette knives or ground on steel rollers, the product will be blackened by the abrasion of the steel surfaces. The furnace product is then passed through disintegrator mills, which deliver a finished product of uniform fineness (300 mesh), the particles being roughly spherical with a diameter of the order of 1/μ. Satisfactory colour and texture is obtainable with a purity of 98% TiO<sub>2</sub>. Titanium oxides up to 99.8% purity can be prepared where high purity is essential, but such materials are useless as pigments. The high refractive index of 2-7, combined with the low density of 3.7 result in a material having the highest opacity and staining power of any white pigment. Further, its stability to chemical attack by both alkalis and acids enables it to be used in almost any medium, and it finds extensive use in cellulose lacquers, alkyd and other flowing synthetic resins, etc. It is chemically inactive and non-toxic but has, however, one serious shortcoming. On exposure in oil media out of doors, paints containing it chalk badly and eventually fail. It would appear that chemical inactivity is not necessarily a desirable property in itself. The moderate activity of white lead which results in hardening of the film without cracking or checking is to be preferred to the activity of zinc oxide, which promotes checking, or the inactivity of titanium oxide, which promotes chalking. To some extent this defect can be overcome by the addition of zinc oxide, antimony oxide, or witherite in substantial amount. This defect is connected with the crystalline form of the product. Titanium oxide, TiO<sub>2</sub>, is trimorphous, crystallising in three forms (anatase, tetragonal, p 3.9; brookite, orthorhombic, p 4.0; and rutile, tetragonal, p 4.3). The anatase form separates around 860°c., whereas brookite is formed at about 1,000°c., and the rutile form at still higher temperatures. Both anatase and rutile are tetragonal, but in rutile the prismatic habit is more strongly developed. The rutile form is less prone to cause chalking, and according to B.P. 479072 the incorporation of small amounts of antimony oxide prior to fumacing favours its formation. Unfortunately, rutile titanium oxide pigments do not possess good colour. Titanium oxide in admixture with many dyestuff pigments accelerates fading, especially in pale tints. Composite pigments of titanium oxide and barium sulphate in which the titanium oxide content varies from 25-70% are extensively used under the name of titanium whites. Calcium-base titanium white is a similar pigment in

which the barium sulphate is replaced by calcium sulphate. Titanium lithopone is said to be co-precipitated pigment made from zinc sulphate, barium sulphide, and titanium oxide, calcined in the same way as for lithopone (?#), but precisely similar properties are obtainable by blending lithopone and titanium oxide. Lead titanate is prepared by heating together titanium oxide and litharge in molecular proportions to form PbTiO<sub>3</sub>. It possesses excellent weathering properties and is free from chalking, but is of a pronounced yellow to buff colour.

**Tin Oxide.**—Stannic hydroxide or orthostannic acid, Sn(OH)<sub>4</sub>, is employed in ceramic glazes and in vitreous enamels, but is seldom used in decorative or artistic paints. Stannic oxide, SnO<sub>2</sub>, occurs in three crystalline forms isotrimorphous with the three forms of titanium oxide. Both are chemically similar in properties to silica, SiO<sub>2</sub>.

**Summary of Properties of White Pigments.**—To avoid repetition and in order to present a comparative picture of the white pigments, mainly from the point of view of their use in paints, the following data are appended:

Pigment.	Density.	Refractive index.	Oil absorption, % wt.	Approx. particle size, μ.	B.S.*
White lead	6.8	1.9	7-10 (Stack) 9-13 (Chamber)	1-20	239
Basic lead sulphate	6.4	1.89	7-12	—	637
Antimony oxide	5.75	2.2	10-15	1	338
Zinc oxide (acicular)	5.65	1.9	14-21	1	254
Lithopone	4.3	1.84	12-20	30	296
Zinc sulphide	4.9	2.3	—	1	—
Titanium oxide	3.7	2.7	20-30	1	392
Titanium white (reduced types)	—	—	—	—	636

\* All these British Standards are published together as B.S. 239-1935.

These are average commercial figures and not intended to indicate limits permitted by specifications quoted.

British Standards may be obtained from the British Standards Institution, 28 Victoria Street, London, S.W.1, and should be consulted for precise details and methods of tests.

A method for determining relative resistance to chalking of titanium pigments is given in B.S. 1269-1945.

**EXTENDEDS.**

Materials notably deficient in both colour and opacity are commonly employed along with suitable pigments to re-inforce the mechanical or rheological properties or to modify the surface characteristics or finish of the mixtures in which they are dispersed. In general these materials possess low refractive indices, so that they are relatively transparent in oil. Some, such as

silica, may be added to give "tooth" or roughness to undercoats in order to secure proper adhesion, others of relatively high oil-absorption such as magnesium carbonate or asbestine may be added to improve suspension of the pigment or to obtain matt finishes. Extenders are also employed as bases on which to strike dyestuffs, but this aspect will receive attention under dyestuff pigments. The presence of excessive amount of extender may generally be regarded as adulteration.

Many extenders are natural minerals, and may be mined as such or in conjunction with other minerals with which they occur. They may be grouped as:

*Sulphates* of barium, strontium, calcium.

*Carbonates* of barium, calcium, magnesium.

*Silicates*, etc., e.g., silica, china clay, asbestine, mica.

**Sulphates.**—*Barytes*,  $\text{BaSO}_4$ , also known as heavy spar, occurs in many parts of the world, notably in Germany, the U.S.A., Italy, and this country. The annual production in Great Britain is 66,000 tons, of which some 40,000 are taken by the paint industry. Used in moderation it increases the hardness and resistance to abrasion of paint films and certainly does not detract from their durability, but when used in excess of 15% purely as a cheapening agent the obliteration power and other properties are adversely affected. It is also extensively used as a base on which to strike cheap reduced qualities of the various dyestuff pigments, chromes, Brunswick Greens, etc., and in the filling and surfacing of paper, and in the dressing of fabrics. Good grades run 90-95% purity and should be substantially free from silica. Its high density (4.5) and low refractive index (1.63) make it practically transparent in oils ( $n=1.48$ ). It is relatively coarse in texture, particle size varying from 5 to 100  $\mu$ . (300 mesh = 53  $\mu$ ). Micronised barytes is a specially finely ground variety, the particle size varying from 4 to 9  $\mu$ .

*Blanc Fixe* is the precipitated form of barium sulphate, which is employed wherever the crystalline character of barytes precludes its use. It is extensively used as the base on which to strike fine colours used in printing inks, high quality enamels, and artists' water colours. Particle size varies from 1.5  $\mu$ . It is relatively transparent in oil, but owing to its finer particle size is more opaque in water than is barytes. It is known also under the names of permanent white, process white, and constant white.

*Strontium white*, or celestite,  $\text{SrSO}_4$ , occurs at Yate, near Bristol, where it is found a few feet below the surface as a white transparent mineral, tinted pink due to traces of iron. It is somewhat softer and less insoluble than barytes and is used similarly, especially in fillers and surfacers, to which it confers easier rubbing properties in the preparation of smooth surfaces.

*Terra Alba*, known also as mineral white, or Gypsum,  $\text{CaSO}_4 \cdot 2\text{H}_2\text{O}$ , is extensively used as a cheap mineral filler or extender. It is much softer than either barytes or celestite and is appreciably soluble in water. Its use in paints is deleterious, resulting in corrosion on steel

surfaces. Its texture is crystalline and it produces a woolly texture in oil. It is relatively transparent in both oil and water, although it is used to some extent in water paints.

*Satin white* is a precipitated white base prepared by the addition of milk of lime to a solution of aluminium sulphate, and is used to some extent in the preparation of lake pigments and in the surfacing of "art" papers.

**Carbonates.**—*Witherite* is natural barium carbonate,  $\text{BaCO}_3$ . In Northumberland and Durham a vein of this mineral up to 16 ft. in thickness is worked, and supplies the bulk of the world's production (about 10,000 tons per annum). Elsewhere it is rarely found unassociated with other minerals. Although barium compounds are scheduled as poisonous, the use of barium carbonate in paints, plastics, pigments, printing inks, etc., is exempted from the general regulations (S. R. & O., 1935, No. 1239, Rule 11, Third Sch., Group 1). Large amounts are used in industry without injurious effect on the health of workers. It has useful properties in paints, but should be avoided where these are liable to come into contact with food (e.g., printed wrappers). It is claimed to reduce the chalking of titanium pigments in paints. Precipitated barium carbonate is finer and softer and is also used.

*Whiting or Paris white* is natural calcium carbonate,  $\text{CaCO}_3$ , which has been washed and ground. It is extensively used as the basis of most distempers, being relatively opaque in water media and conferring desirable brushing properties. It is mostly prepared from chalk, huge deposits of which occur stretching from Antrim, Northern Ireland, to the Crimea. In places these deposits have been completely denuded but elsewhere they have been consolidated into limestones, a crystalline variety abounding in fossil remains, and in some places into marble, in which the crystallisation process has destroyed all fossil remains. Powdered marble is sometimes used on account of its higher purity and highly crystalline texture. In the past, a prejudice against the presence of calcium carbonate in pigments or paints still persists, but it is well known that moderate amounts (up to 15%) do not adversely affect the durability of paint under normal outdoor conditions. The term Paris white is generally held to connote a superior quality, especially as regards colour and freedom from coarse siliceous particles. When a white finish is desired it is usual to add ultramarine blue in quantities sufficient to overcome the distinct yellowish cast due to the presence of iron.

*Magnesite*,  $\text{MgCO}_3$ , is similar in properties to whiting, but owing to its higher oil absorption finds its chief use in the formulation of matt finishes.

**Silicates.**—*Silica*,  $\text{SiO}_2$ , occurs extensively as sand, flint, quartz (rock crystal), kieselguhr (diatomaceous earth), and as an amorphous powder of volcanic origin in the Greek island of Milos. The denser varieties are extensively used in primers and undercoats to provide "tooth" or adhesion for the subsequent coats, but owing to its extremely hard nature (hardness 7, Moh's scale) it causes excessive wear on mills

and renders subsequent rubbing down arduous. It should therefore be used sparingly or in controlled amounts. The amorphous forms are used as suspending agents and for the production of matt finishes. Under the microscope the typical conchoidal fracture, the presence of diatoms, and its characteristic properties under polarised light render detection of the various types a matter of no great difficulty. Siliceous dust entering the lungs causes severe inflammation, leading to silicosis, and of recent years stringent restrictions have been placed on its use in the dry State in this country. The risk associated with its occasional use in paint is considered negligible.

**Asbestine.**—Asbestos is a term applied somewhat loosely to various minerals occurring in fibrous form, including anthophyllite, hornblende, tremolite, actinolite, crocidolite, serpentine, and talc. Originally, the asbestine used in paints was the fine powder resulting as waste from the weaving of asbestos cloth or cord. The composition is variable, being chiefly hydrated silicates of magnesium, calcium, and iron. Of recent years white asbestine has been chiefly of the talc variety, which is essentially hydrated magnesium silicate. It is very soft (hardness 1, Moh's scale); density 2.3-4, and oil absorption 25-30. Its use is almost entirely confined to the production of matt finishes and as a means of preventing settlement in paints. Asbestine is prone to cause asbestosis, a malady closely akin to silicosis, and similar restrictions apply.

**China Clay, or Kaolin,** has the approximate composition  $Al_2O_3 \cdot 2SiO_2 \cdot 2H_2O$ . It is derived from the weathering of granite *in situ*, by the process known as kaolinisation, whereby the soluble constituents are leached out and a mass of white insoluble residue is left behind. The chief production in this country is at St. Austell, Cornwall, with an output of about 1 million tons annually. After levigation to remove sand and mica particles it is run through 100-mesh sieves into settling pits, filter pressed, and dried. It is extensively used in the manufacturing of pottery, paper, and rubber, and linoleum, and finds a relatively insignificant use in paint. It is, however, used as a base on which to strike dye-stuff pigments (see "China Clay, its Composition, Preparation, and Uses," Collins, Chem. and Ind. 1923, Feb. 2). Colloidal forms of china clay, peptised by means of alkalis and electrolysed using a positively charged drum, to which the negatively charged china-clay particles are attracted and removed by scrapers, have been put forward under the proprietary names of "Stockolite," "Cotolpo," etc. Bentonite is a naturally occurring form found principally in the U.S.A. and Canada, characterised by its capacity of swelling to several times its own volume when wet with water and setting to a stiff gel. It finds use in water paints as a suspension agent. Fuller's earth is similar in properties and was used originally to absorb oil or grease from fabrics. Neuberger chalk is a particularly fine variety used as a polishing agent, whilst white and green earths are much used as bases for the preparation of colours fast to lime for use in distempers. Green earth is

mined in the vicinity of Verona under the name of "terra verde" and owes its colour to the presence of glauconite, a hydrated silicate of iron, aluminium, and potassium. It has a dull greenish colour, is lacking in opacity and staining power, and is better regarded as an extender than as a pigment.

**Slate Powder.**—Slates are derived from clays under the influence of terrestrial pressures, which cause orientation of the particles, leading to the formation of definite planes of cleavage, along which the rock may be split into roofing materials (v. Vol. II, 138a). The waste formed by the trimming of roofing slates is ground to a fine powder and air floated. It is generally grey in colour and forms a very suitable material for the making of grey fillers and stoppers, and as an inert extender in cheap paints, asphalt, and other flooring compositions, linoleum, and rubber compositions.

**Summary of Properties of Extenders.**—The following are average commercial results obtained on good-quality materials. Owing to the wide variations of these materials they cannot be taken as indicating ~~wide limits~~, but are intended primarily as characterising the different extenders:

Extender.	Density.	Refractive index.	Oil absorption.	Approx. particle size, $\mu$ .	B.S.*
Barytes (Micro-nised)	4.5	1.63	8-12	5-100	260
Blanc Fixe	4.2	1.63	25-30	4-9	—
Strontian white	3.9	1.62	—	1-5	281
Terra Alba (white)	2.3	1.59	20-25	5-200	—
Witherite	4.3	1.53	9-12	60	—
Magnesite	3.0	—	—	10	—
Whiting	2.7	1.60	15-20	5-20	—
Silica (Milo-white)	2.6	1.55	—	40	301
Asbestine	2.2	—	—	10	—
China clay	3.0	—	25-30	1	255
Slate powder.	2.6	—	30-60	—	—

\* Published together as B.S. 255-1938. #

FEKBUGINOUS PIGMENTS AND EARTH COLOURS.

This extensive group of pigments, the pigimentary properties\* of which are due in the main to the presence of iron, may be divided into two classes, naturally occurring and chemically prepared. Pigments of either class are commonly submitted to calcination, whereby the shade may be altered or a whole range of shades produced, in which case the prefix *raw* or *burnt* may be used as in the case of Sienna or Umber. Blended products are also common, in which the properties of the natural oxide have been modified by the addition of chemically prepared ferruginous pigments in order to comply with specification requirements or to improve the colour or tintorial strength.

**Naturally Occurring Iron Oxide Pigments.**—This class comprises a large number of pigments varying in colour from pale yellow through red to crimson, brown, and black. The

colour is due mainly to iron in the form of hydrated oxide, oxide, or silicate, modified in some cases by the presence of manganese, and varies according to the locality in which they are mined. In general the hydrated forms are yellowish, becoming redder as dehydration to oxide occurs, whilst the presence of manganese tends towards browner shades. In some cases the composition approximates to that of haematite ( $\text{Fe}_2\text{O}_3$ ) or magnetite ( $\text{Fe}_3\text{O}_4$ ) whilst in many others the iron content may be quite low, the balance generally consisting of silica, clay, calcium carbonate or sulphate, organic matter, etc. Methods of mining and the care expended in preparation for the market vary considerably in different countries, but usually only those deposits which can be worked with a minimum of treatment to provide satisfactory pigments are capable of economic exploitation.

Ochre.—Ochres may be regarded as hydrated oxides of iron, associated with a considerable amount of silica. They are yellow in colour, somewhat opaque, low in iron, and relatively weak in staining power. At one time exported extensively from France, these were obtained mainly from the Yonne and Vaucluse districts; the various qualities were designated by initials still in common use, e.g., J.F.L.S., the significance of which is here given:

J. Jaime	Yellow.	E. Extra	Extra.
L. Lavé*	Washed or levigated.	F. Foncé	Dark.
C. Citron	Light yellow.	O. Or	Gold.
T. Très	Very.	R. Rouge	Red.
		S. Superfin	Superfine.

Excellent qualities are also obtained from Italy, India, and South Africa. In this country, Oxford ochre was formerly a well-known variety, but the deposit is now exhausted. West of England ochres, notably from the Golden Valley district, and the Derbyshire ochres are well known and of excellent quality. The iron content of ochres varies from 13 to 75% as  $\text{Fe}_2\text{O}_3$ ; typical analysed are as follows:

Ochre.	Oxide of iron.	Loss on Ignition.	Silica.	Alumina.	Calcium sulphate.	Calcium carbonate.	Magnesium salts.
Italian	67-28	11-50	15-75	3-67	Nil	1-78	Nil
African	61-13	12-10	21-00	3-87	1-02	0-14	Trace (0-70 NaCl)
Bristol	47-31	8-00	27-75	5-69	0-524	9-61	1-12 as $\text{MgCO}_3$
Indian	33-00	12-80	49-75	3-50	Trace	0-90	Trace
Spanish	73-89	11-50	6-50	5-70	1-16	1-12	Nil
Devon	18-00	0-00	68-00	2-00	0-41	1-67	—
French	—	—	—	—	—	—	—
J.F.L.S.	13-88	7-00	76-00	2-12	0-35	0-42	—

On calcination ochre becomes reddish and is termed "burnt" or "red-ochre."

Sienna.—There is no definite line of demarcation between ochres and siennas, but the pronounced transparency of the latter does in fact lead to a sharp distinction being made in use. Raw siennas are much higher in iron content (on the average over 50% as  $\text{Fe}_2\text{O}_3$ ) and generally contain a small amount of manganese (0-1-1-6%). They are decidedly stronger in staining power and are used as stainers or

glazing colours (see definition; p. 623c) in the preparation of natural woods which are to be varnished or French polished, and in tin graining of painted surfaces. Sienna, as the name implies, is obtained from the vicinity of the Italian city of Sienna, and from Sicily. Raw sienna, which is not nearly so abundant in nature as ochre, is a brownish-yellow pigment possessing a greenish cast. A typical analysis is as follows:

	%
Ferric oxide, $\text{Fe}_2\text{O}_3$ . . . . .	64-96
Manganese dioxide, $\text{MnO}_2$ . . . . .	1-46
Alumina, $\text{Al}_2\text{O}_3$ . . . . .	7-26
Calcium oxide, $\text{CaO}$ . . . . .	1-30
Silica, $\text{SiO}_2$ . . . . .	14-02
Combined water . . . . .	1-94
	<hr/> 98-40

Burnt Sienna, obtained by the calcination of raw sienna, is of a rich transparent orange-brown colour, the depth of which may be varied according to the temperature and conditions of heating. It finds considerable use as a glazing colour and when reduced with an opaque white pigment yields warm yellow tones unobtainable with ochres.

Umber.—Umbers are differentiated from ochres and siennas by the higher manganese content and much darker colour. They are not too plentifully distributed in nature; a poor quality is mined in this country, but the best qualities, known as Turkey umber, have for centuries been obtained from the island of Cyprus and imported into this country via Constantinople. Raw Turkey umber is dark brown in colour, with a peculiar greefish cast, containing 30-66% of  $\text{Fe}_2\text{O}_3$  and 16-30% of  $\text{MnO}$ , the balance being organic matter, silica, and alumina.

Burnt Umber, as the name implies, is a calcined umber. It is a dark brown in colour with a reddish cast, the change on calcination not being nearly so marked with umbers as with ochre or siennas. Ochres, siennas, and umbers are somewhat hygroscopic, and the determination of moisture therein is best carried out *in vacuo* according to the method of the British Specification No. 312.

Red Oxide of Iron.—Extensive deposits of natural oxide of iron, hematite,  $\text{Fe}_2\text{O}_3$ , occur throughout the world, but only those deposits which have the required physical properties are of interest as pigments. In the Malaga district of Spain, an extensive deposit is worked, yielding an oxide averaging 80-90%  $\text{Fe}_2\text{O}_3$ , known in this country as Spanish oxide. This is extensively used in the manufacture of red oxide paints for the protection of steel structures. It has excellent obliteration and brushes out well. When reduced with whites it shows good staining power, yielding tints with a yellow undertone.

Another deposit occurs at Ormuz on the Persian Gulf, the oxide being known as Gulf red. This has an even brighter colour, and yields somewhat bluer undertone on reduction with white. Although it averages only 70%  $\text{Fe}_2\text{O}_3$  and is considerably higher in silica, it commands a better price on account of its bright colour.

Comparative analyses of these two oxides are as follows:

	Spanish, %	Persian Gulf, %.
Ferric oxide . . . . .	90-60	68-41
Alumina . . . . .	2-87	4-41
Manganese dioxide . . . . .	0-15	—
Calcium oxide . . . . .	0-50	1-26
Magnesium oxide . . . . .	0-18	—
tyater (combined) . . . . .	2-18	3-00
Silica . . . . .	3-3%	22-45
	99-84	99-83

In this country useful deposits are worked at Winford, Somersetshire,\* and in the Forest of Dean, Gloucestershire. The famous Crawshay red, averaging up to 95% Fe<sub>2</sub>O<sub>3</sub>, was obtained from the latter district, but is no longer worked. Another good oxide is mined jji Derbyshire, whilst from Brixham a well-known red of that name was obtained.

**Black Oxides of Iron.**—Magnetite or magnet& iron ore, Fe<sub>3</sub>O<sub>4</sub>, is found in Devonshire and Cornwall, associated with other minerals in metalliferous lodes or veins. It crystallises in the cubic system, often occurring in small octahedra. *Micaceous iron ore* or specular iron ore is, however, a form of haematite, Fe<sub>2</sub>O<sub>3</sub>, crystallising in the hexagonal system, and occurring as masses of rhombohedral crystals, black in colour with a metallic splendid lustre. It is non-magnetic and contains no mica, but is employed in anti-corrosion paints on account of its micaceous structure—platelets/ which " leaf " or overlay one another so as to offer additional resistance to the penetration of moisture. If ground, it changes\* to a red powder, due to destruction of the crystal structure. These oxides are poor in colour and pi weak tinting strength, and owing to their high density (4-5-5-0) they settle out rapidly in paints. Much of the black oxide useg to-day is chemically prepared (v. *infra*).

**Chemically Prepared Iron Oxide Pigments.** *Turkey and Indian Reds.*—These are prepared by the calcination of ferrous sulphate or green copperas, FeSO<sub>4</sub>.7H<sub>2</sub>O. The copperas is first dehydrated to remove a] much water of crystallisation as possible and then heated in muffle furnaces to a temperature of about 850°C, precautions being taken to absorb the sulphurous fumes. It is then ground in water, washed, and levigated to remove coarse particles. The lighter and brighter reds are known as Turkey red, and the deeper reds obtained at the higher temperatures are known as Indian reds. Both approximate 97% Fe<sub>2</sub>O<sub>3</sub>, but at the higher temperatures a denser structure develops, resulting in weaker tinctorial strength and bluer undertone.

*Purple Oxides of Iron.*—An inferior grade of Indian red is obtained from the burning of pyrites, FeS<sub>2</sub>, in the manufacture of sulphuric acid. Owing to the high temperatures employed and lack of care (so far as pigmentary properties are concerned), these oxides vary in colour from

that of deep Indian red to dark purple or chocolate. They are very dense and hard and are seldom finely ground, so that bad settlement in paints is prevalent. They are weak in tinctorial strength and very blue in undertone. The iron content averages 85% Fe<sub>2</sub>O<sub>3</sub>.

Turkey red and Indian reds may also be made from galvanisers' waste pickle liquors, by first neutralising the free acid by means of iron scrap and then treating the liquors with milk of lime, whereby ferrous hydroxide is precipitated. By oxidation with air at low temperatures, products generally poor in colour are obtained, but on calcination these give bright reds of the Turkey and Indian red type. If the oxidation is carried out at the boiling-point, black magnetic oxide of iron is obtained.

*Venetian Red* was originally a natural red ochre found in the vicinity of Verona, but the name is now applied to a manufactured oxide heavily reduced with calcium sulphate.

*Burntisland Red* is a low-grade iron oxide obtained as a by-product from the extraction of aluminium from bauxite by the Bayer process. Bauxite, an impure aluminium oxide containing much iron oxide, is extracted by means of caustic soda, which dissolves the aluminium and leaves the iron oxide and unattacked clay as a residue or " red mud." The composition is variable, but it contains on the average some 40% of ferric oxide and is a useful red where brightness or colour is unimportant.

*Ferrite Yellows.*—Although chemically prepared oxides have been in use over many years, attempts to produce hydrated oxides yellow to orange in shade have in the past been relatively unsuccessful. Gradually, over the last 20 year, however, success has been achieved and to-day a whole range of yellows, brighter and stronger than the natural oxides or ochres are available. Ferrous sulphate solutions are pumped over scrap iron, the solution being simultaneously aerated, so that iron is dissolved 2nd the ferrous sulphate solution oxidised. The ferric sulphate then partly hydrolyses to hydrated ferric oxide and sulphuric acid, the free acid then dissolving more iron thus:

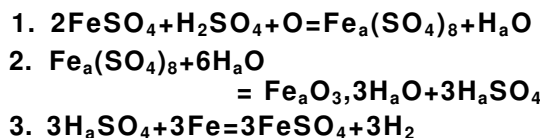

Considerable variations in shaue are obtainable by adjustment of temperature and concentration as well as pH. The ferrite yellows or mars yellows so produced are soft in texture, of good opacity and of excellent tinctorial strength. They possess a much higher oil absorption than natural ochres and, being free from silica, do not damage the steel nollers of modern paint milling machinery. They ar% easily dispersed in oil and can be standardised in a manner that is impossible with natural ochres. Care is, however, necessary in certain cases, especially with oil-bound emulsions, as phase reversal may occur, due possibly to the presence of soluble salts or *the* hydrophilic properties of these pigments. Trouble has also been experienced with fading in oil media.

**Black Oxides.**—From the reduction of nitrobenzene to aniline by means of scrap iron, a black oxide of iron is obtained, which finds some use as a pigment. It has inferior drying properties, due to tarry impurities, and is very weak in tinctorial strength. By carrying out the preparation of ferrite yellow at the boiling-point instead of at low temperatures, black oxides can be obtained, possessing magnetic properties. These have excellent strength, are very fine, and possess quite remarkable polishing properties, imparting to glass, in particular, a bright lustre. Verted into bright reds.

**Physical Structure.**—The physical structure of hydrated oxides is important and has been investigated by means of X-ray diffraction spectra. According to Wagner (Faint and Var. Prod. Man. 1931, 34) they are amorphous and transparent when freshly precipitated, but upon ageing at ordinary temperatures, orientation occurs with development of crystal growth of the monohydrate,  $\alpha$ -goethite,  $\text{Fe}_2\text{O}_3 \cdot \text{H}_2\text{O}$ . If precipitated by means of lime, the resultant crystal form is pseudomorphous after  $\text{CaCO}_3$ . When dehydrated, all artificial hydrates exhibit a hsematitic structure. By means of adsorption of basic dyes, the presence of silicic acid can be demonstrated, aluminium silicate only adsorbing the dye superficially and iron hydroxide not at all. Sienna from Tuscany exhibits the  $\alpha$ -goethite structure, the particles being cemented together by colloidal silicic acid. The following are the relevant British Standards:

- 272-1936. Natural Bed Oxides of Iron.
- 306-1936. Manufactured Bed Oxides of Iron.  
(Published with B.S. 272-1936.)
- 306-1937. Black Oxide of Iron.
- 312-1937. Baw and Burnt Sienna.
- 313-1937. Baw and Burnt Umber. (Published with B.S. 312-1937.)
- 337-1937. Qphre. (Published with B.S. 312-1937.)
- 339-1937. Purple Oxides of Iron. (Published with B.S. 306-1937.)
- 370-1938. Venetian Bed.
- 694-1936. Blended Bed Oxides of Iron.  
(Published with B.S. 272-1936.)

#### CHROMES.

Of all the yellow pigments available, none have a wider application or are used in such quantities as the chromate pigments. This group covers a wide range of colours from primrose through golden yellow to scarlet and red. From them a still wider range of greens may be made by admixture of blues—mostly Prussian blue—which are known as chrome or Brunswick greens.

In general the chromes possess excellent weather resistance, good opacity, and low oil absorption. They are not, however, resistant to alkalis, which cause reddening due to the formation of basic compounds, nor are they proof against discoloration in industrial atmospheres, where sulphurous gases are present in the atmosphere. The chromates of lead are by far the most important, but those of zinc, barium, and calcium have certain applications, which will receive mention.

**Lead Chromes.**—Middle chrome or golden yellow as it is frequently termed can be regarded as normal lead chromate,  $\text{PbCrO}_4$ . It is made by the precipitation of normal sodium, or potassium chromate with a soluble salt of lead. The dichromate is, however, employed commercially, being neutralised with soda ash before the addition of the lead salt, thus:

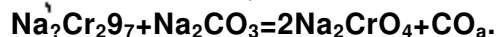

This is essential for the preparation of clean chromes, otherwise a large excess of acid will be liberated during precipitation. To avoid the possibility of any excess of alkali, which would redden the chrome, and to ensure stability, middle chromes are kept slightly acid, and excess lead should be present throughout. Thus the chromate solution is added to the lead salt solution and not vice versa.

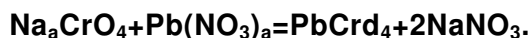

Lead nitrate may be replaced by lead acetate, basic acetate,\* chloride, or basic chloride (as suspensions), but the best qualities are made from nitrate.

**Lemon chrome** is a paler shade obtained by the co-precipitation of lead sulphate with lead chromate. This is not a mere mixture, nor is there any evidence of the formation of a double salt, but according to Lederle (Bev. Prod. Chim. 1937, 263) the lead sulphate is present in solid solution in lead chromate. Whatever the precise form, it is quite definite that lead sulphate stabilises the pale forms, for although lemon chromes can be made by striking cold in the absence of lead sulphate, such chromes revert to the middle shade on ageing. Lemon chromes, on ageing, undergo a change from rhombic to monoclinic form, accompanied by an appreciable alteration in sedimentation volume. This change can be accelerated by prolonged stirring or slight heating (Clay and Watson, J. Oil Col. Chem. Assn. 1944, 27, 5). The limits of composition of this type of chrome may be considered to be between  $\text{PbCrO}_4 \cdot 0.5\text{PbSO}_4$  and  $\text{PbCrO}_4 \cdot 3\text{PbSO}_4$ .

The method of manufacture is similar to that of middle chrome except that sodium sulphate is added to the dichromate and soda ash before running down into the solution of lead salt.

**Primrose Chromes.**—There is a limit to the increased paleness obtainable by the use of sulphate, and if still paler colours are desired, other methods must be resorted to. The addition of a small amount of aluminium sulphate to the dichromate solution before precipitation, followed by the appropriate amount of soda ash after precipitation to bring down the alumina hydrate, is the usual method of making these pale shades, which are used principally by the printing ink industry. The finished product approximates to the composition  $\text{PbCrO}_4 \cdot 3\text{PbSO}_4 \cdot \text{Al}(\text{OH})_3$ .\* All the above are struck cold, but the shade may be varied by raising the temperature where necessary.

**Orange Chromes.**—Middle chromes, if boiled, or still more so if heated with caustic soda,

\* This corresponds to 3-8% of  $\text{Al}_2\text{O}_3$  on the formula given. B.S. 282 is permissive to the extent of  $\text{Al}_2\text{O}_3$  not exceeding 4%.



deepen in shale and become basic in composition. By varying the basicity of the precipitating "liquors" (e.g., by using basic lead acetate and by boiling after precipitation, varying shades of orange chromes are prepared. The composition approaches that of



As the shade deepens it becomes duller and the tinctorial strength weakens.

**Red Chromes.**—A highly basic chrome of much brighter hue may be made using white lead and dichromate solution. Bright deep reds possessing a marked crystalline structure are thus obtained. On grinding, the crystalline structure is broken down and the colour becomes a dull orange. These reds were known as Persian red, Chinese red, and Derlgr red and were used to a fairly large extent, but the production is now almost discontinued.

**Scarlet Chromes.**—Much cleaner and brighter chromes are now made by the co-precipitation of lead molybdate with lead chromate and sulphate. These chromes darken somewhat more than yellow chromes on exposure, but their superior strength and obliterating power are a distinct advance on the older type. The composition approximates to that of



**Light-fastness of Lead Chromes.**—Although lead chromes may be regarded as quite durable and fast to light, occasional failures in this respect have occasioned investigation. Nitrate middle chromes are, by general consent, considered faster and more satisfactory than acetate chromes. To some extent this may be due to impurities in commercial acetic acid, but Wagner (Paint and Var. Prod. Man. 1934, 10, No. 5, 10) considers it may be due to crystalline form, the monoclinic being more stable to light than the rhombic. Baker and Barradough (Oil and Col. Trades J. 1939, 95, 1, 142) have pointed out that chromes blacken more readily in oily media and suggest that interaction with oil or driers to form peroxides, which in turn decompose the chrome, may be the cause.

B.S. 282-1938 covers lead chromes.

**Zinc Chromes.**—Zinc chromes possess no definite chemical composition, nor do they form the range of shades obtainable with lead chromes. They are generally made only in pale shades, and are valued for the making of a bright range of greens, such as are not obtainable using lead chromes. As yellow pigments they are not very satisfactory, possessing neither strength nor opacity. They are not reddened by alkali, and so may be used in distempers, which are often applied on alkaline cement or plasters, but are not very weather-resistant.

The composition of zinc chrome is stated by Ellis, Fox, and Hirst (J. Oil Col. Chem. Assoc. 1928, 11, 194) to be approximately  $\text{K}_2\text{CrO}_4, 3\text{ZnCrO}_4, \text{Zn(OH)}_2$ , and the method of preparation is given by Buchan and Fox (*ibid.*, p. 198). In general, these pigments are made from zinc oxide and potassium dichromate in the presence of sulphuric acid. They are decidedly basic and appreciably water-soluble, so that

washing of the precipitate must be brief, otherwise hydrolysis will proceed so far as to render the product useless as a pigment. Potassium is invariably retained in the pigment when potassium dichromate is used; sodium dichromate is not used on account of its greater solubility and hygroscopic nature.

The chief merit of zinc chrome is in the prevention of corrosion, particularly of light alloys used in aeroplane construction. For this purpose the pigment is specially prepared, the degree of solubility in water and freedom from soluble salts of a corrosive nature (e.g., chlorides, sulphates, etc.) being very important. Specification D.T.D. 337A (1946) prescribes methods of test.

B.S. 389-1938 (published with B.S. 282-1938) covers zinc chromes.

**Barium Chromate,  $\text{BaCrO}_4$ .**—The main use of this material (which has been considerable during the Second World War) is as a constituent of a jointing compound used in aircraft construction. A small quantity is used for pyrotechnic purposes, but this use is almost negligible in comparison with the main use in jointing compounds.

The purpose of the jointing paste is to prevent electrochemical corrosion at the junction of two dissimilar metals (particularly if one of these is a magnesium alloy) in the presence of sodium chloride. The method of use is to apply a liberal coating of the jointing compound at the point where the junction is to be made before bringing the two parts together.

The specification calls for a high standard of purity (98% of barium chromate) and a low limit is imposed of water-soluble matter in an oil varnish medium impregnated with barium chromate (Specification D.R.D. 369 (1938)).

In contrast with both zinc chrome and calcium chromate, barium chromate is for all practical purposes insoluble in water. It is not therefore used to any great extent in anti-corrosion priming paints, in which cases, according to modern views, it is desirable to use a chromate pigment with a small but definite soluble chromate value.

**Calcium Chromate,  $\text{CaCrO}_4$ .**—Calcium chromate has really only one use, and that is for corrosion-inhibiting cartridges used in aircraft fuel tanks. The material has been used for this purpose for some time, but it is only recently that a specification has been issued for it under D.T.D. 49. This specification defines limits for calcium content, total chromate content, soluble chromate, volatile matter, and freedom from impurities.

Calcium chromate is relatively soluble in water (much more so than zinc chrome) and the specification upper limit for soluble chromate calculated as  $\text{CrO}_3$  is 4.5%. Its comparatively high solubility makes it a not very easy pigment to manufacture, particularly as the top limits for sulphates, chlorides, and nitrates in the specification are 0.1% in each case. The difficulty, of course, is to wash out the unwanted soluble materials without at the same time reducing the yield of calcium chromate to an uneconomic figure.

The high soluble chromate value of calcium chromate apparently makes it suitable for use

in places, such as fuel tanks, where a comparatively very small proportion of water is present; its solubility is too high for it to be a satisfactory paint pigment.

#### OTHER YELLOW PIGMENTS.

**Cadmium Pigments.**—A valuable range of pigments is supplied by cadmium sulphide, selenide, and telluride. Cadmium sulphide is yellow, and although cadmium selenide is a brownish-black of no interest, mixed sulphides and selenides provide a pleasing range from orange to maroon/the latter approximating the composition  $CdS, CdSe$ , beyond which dull products result.

These pigments may be produced by precipitation of cadmium salts with sodium sulphide or hydrogen sulphide or by the roasting of cadmium carbonate with sulphur. An extremely fine product may be produced by the simultaneous vaporisation of cadmium and sulphur out of contact with air, so that combination can occur. Brilliant lemon yellows may be produced by melting sodium thiosulphate in its own water of crystallisation, adding cadmium sulphate and zinc oxide, and calcining at  $400-500^{\circ}C$ .

For pale results, zinc-cadmium sulphides may be used. The term "*Cadmopone*" was applied about 1925 to mixed cadmium-zinc sulphide and barium sulphate complexes, made in imitation of lithopone (*q.v.*) (see Ward, J. Oil Col. Chem. Assoc. 1927, 10, 4).

Cadmium sulphides have been used for many years as artists' colours, but it was not until about 1933, when the price of cadmium fell to under 2s. per lb., that commercial interest was aroused. They are, fast to light, of excellent opacity, and very low density—a marked advantage over chromes where stoving finishes and cellulose lacquers are concerned. They are extensively employed in the decoration of ceramics, as unlike zinc sulphide, cadmium sulphide is not oxidised on heating.

**Arsenic Sulphide or Kings Yellow,  $As_2S_3$ .**—Originally prepared from natural orpiment,  $As_2S_3$ , it is obtained by precipitating an acid solution of arsenious oxide with hydrogen sulphide or sodium sulphide. It may also be prepared by heating together white arsenic and sulphur. It is a bright yellow pigment, but owing to the poisonous nature of arsenic compounds it is now practically obsolete, except for its use in rubber.

#### ORANGE PIGMENTS.

**Arsenic Orange,  $As_2S_2$ ,** is a deep orange pigment, originally obtained from natural realgar,  $As_2S_2$ . It may be prepared by fusing together white arsenic, sulphur, and charcoal.

**Naples Yellow.**—Originally found native on Mount Vesuvius, it has the composition of lead antimonate. It may be prepared by fusing together tartar emetic, lead nitrate, and common salt in the ratio 1:2:4 at  $800^{\circ}C$ .

**Aurorine.**—An unusual pigment, discovered by Fischer, having the composition of a double nitrite of potassium and cobalt. It possesses no advantage over yellow cadmium sulphide and is seldom used.

**Antimony Sulphide.**—Occurs naturally as black/Stibnite,  $Sb_2S_3$ . The red form, known as antimony vermilion, is produced artificially and was introduced by Murdock in 1847. It is prepared by heating together solutions of a-soluble antimony salt and sodium thiosulphate. On reaching  $32^{\circ}C$ , a yellow precipitate is formed, which deepens to scarlet when it is filtered, washed, and dried. It is still used as a pigment for rubber. An orange or golden yellow of similar composition is known as antimony yellow.

**Vermilion,  $HgS$ .**—Identical in composition with mineral Cinnabar  $HgS$  and prepared by the Chinese many centuries ago, it is made by heating together mercury and sulphur in crucibles, when the black sulphide first formed is sublimed and deposited as red vermilion. It is now made by agitating mercury with sodium sulphide solution in the presence of alkali under controlled conditions. Before the advent of aniline dyes, vermilion was prized for its bright colour and durability, and is still used by artists. Its chief use now is in rubber (see B.S. 320-1938).

**Red Lead,  $Pb_3O_4$ ,** is produced by the controlled oxidation of metallic lead, which is carried out in two stages. First, the lead is oxidised at low temperature ( $350-400^{\circ}C$ ) in a "drossing" oven, whereby massicot  $PbO$ , is formed. This is ground in water to remove metallic lead, washed, and dried, and again oxidised at a somewhat higher temperature (ca.  $450^{\circ}C$ ) in a "colouring" oven, during which it is continually stirred, mechanically or by hand. As the difference between the temperature of formation and of decomposition of  $Pb_3O_4$  is only  $50^{\circ}C$  and the physical condition of the massicot largely determines the rate of oxidation, considerable care is required. Red lead is a very heavy pigment ( $p$  8-8-9-1) of considerable opacity. It is seldom used for its colour, but chiefly on account of its excellent anti-corrosion properties as a priming paint next to bare steel. Unless low in litharge content, paints made with it will set like cement in a few days, and a non-setting grade is always used, for which the minimum content of 93-15% as  $Pb_3O_4$  is specified in British Standard 217-1936. The ordinary quality contains 72% of  $Pb_3O_4$  and can be used provided the paint is used at once. The jointing quality, high in litharge to enable it to set quickly, contains 43-72% of  $PbO$ .

**Orange Lead.**—This is a special form of red lead made by calcination of white lead. It is paler, brighter, and of higher oil absorption than ordinary red lead and of much lower density (6\*95). It is used in preference to red lead by the printing-ink industry.

#### BLUE PIGMENTS.

**Ultramarine Blue.**—This was obtained originally by grinding of the precious stone lapis lazuli, a complex silicate of aluminium and sodium containing sulphur and crystallising in the cubic system, which is isomorphous with hauyne, nosean, and sodalite. Since 1831 it has been prepared chemically by the fusing of china clay, soda ash, and sulphur or sodium sulphate together with a reducing substance such as

carbon or rosin. The colour is largely dependent on the silica-alumina ratio. The fusion operation occupies 5 days, and the pots are allowed to cool in the furnace over some 25 days. They are then opened and the contents ground in water and levigated in shallow tanks until a range of shades, differing essentially in particle size, is obtained. The paler shades are filler and of better opacity. Ultramarine varies in shade from pale greenish-blue to violet, the latter being of poor strength and opacity. Ultramarine blue is extensively used in laundry ink, in the surfacing of paper, and as a pigment in paints. It is definitely hydrophilic and is the ideal blue for water paints and distempers. It is used in oils, but is difficult to disperse. It is fast to light and heat but not very weather-resistant. It resists alkalis but is completely decomposed and decolorised by acids, with evolution of hydrogen sulphide. Part of the sulphur is present as such and can be extracted by benzene or carbon disulphide (J. Oil Col. Chem. Assn. 1912, 2, 121; 1925, 8, 202). Ultramarine free from uncombined sulphur is obtainable for printing ink where copper plates are used.

Many other shades of ultramarine have been obtained but few of these are made commercially. B.S. 314-1038 covers ultramarine.

**Cobalt Blue.**—Cobalt blue or Thenard's blue was introduced by Thenard and Proust towards the end of the eighteenth century. It is prepared by precipitation of a cobalt salt with alum and sodium carbonate or with sodium phosphate, followed by calcination. It is a brilliant blue, very pure in tone, with a slight violet cast. It is nearly transparent in oil, inert, and fast to light, heat, acids, and alkalis. It is extremely light and of fine texture and is unequalled for use in stoving enamels.

*SmdU* is really a cobalt glass prepared by fusing silica, potash, and cobalt. It has few of the advantages of cobalt blue and is seldom used now.

*Cerulean Blue* is a variety of cobalt blue in which the alumina is replaced by tin.

**Copper Bluest-Mountain blue** or *azurite*,  $2\text{CuCO}_3 \cdot \text{Cu}(\text{OH})_2$ , *Bremen blue*, prepared by corroding copper with a mixture of common salt and copper sulphate, and *blue verditer*, obtained by precipitating copper sulphate with calcium chloride and treating with lime, are only of historical interest. *Egyptian blue* is of interest as possibly one of the earliest pigments to be prepared chemically. It was made by the Egyptians some 3,000 years ago, and is a crystalline silicate of copper prepared by calcination. It was known to the Romans as *Ceruleum* (Laurie, Proc. Roy. Soc. 1914, A, 89, 418).

**Prussian Blue.**—The discovery of Prussian blue is credited to Diesbach, of Berlin, in 1704, who obtained it by treating calcined blood with green copperas. The first published account of it is by Woodward (Phil. Trans. 1724). It is formed by the precipitation of ferrocyanides with ferric salts, or by the interaction of ferrocyanides with ferrous salts. It is, however, generally manufactured by first forming the white ferrous ferrocyanide and then oxidising this to the ferric compound. In this way better control of the oxidation process can be obtained,

and of the particle size, which in turn determines the tone and bronziness of the product. It is known by a variety of names, which are not entirely synonymous. Chinese or Milori blue should be free from bronze and of a clean greenish undertone. Prussian blue is non-bronzing but of a reddish undertone. Bronze blue, as the name implies, has a copper-bronze top-tone, due to a colloidal condition of the blue resulting in interference effects, especially when viewed at an oblique angle. Steel blues are light in shade and very fine in texture. Gas blues are of inferior quality, manufactured direct from gas liquors instead of the crystallised ferrocyanide. The composition is usually described as ferric ferrocyanide, but potassium or sodium are also present, so that blues are commercially described as potash, soda, or ammonium blues. For the preparation of greens in conjunction with chromes a non-bronzing blue should be used. Bronze blues are used primarily for printing inks.

The method of manufacture consists first in preparing solutions of about 6-10% concentration of ferrous sulphate and sodium or potassium ferrocyanide. The latter is run into the former, a slight excess of ferrous sulphate being maintained and the solution being kept acid. The white or pale blue precipitate of ferrous ferrocyanide is flocculent and readily washed. The oxidation agent is then run in and the whole brought to the boiling-point until oxidation is complete. Potassium chlorate is the most reliable oxidising agent, but potassium dichromate, chlorine, or sodium hypochlorite may be used. Oxidation by means of air is too slow and tends to disperse the blue so finely that difficulty in filtering occurs. Excess of oxidising agent must be avoided, as apart from producing an inferior blue, such blues are liable to spontaneous combustion during drying or grinding. The fully oxidised blue is then dropped into a large bulk of water, washed several times by decantation, and after deoiling the last wash liquors, filtered and dried.

Prussian blue is unattacked by acids, but is extremely sensitive to alkalis. This is very important when using it in very pale greens; the slightest trace of alkalinity will then lead to distinct yellowing of the finish. Alumina hydrate is often present, being deliberately added to improve flocculation and yield a softer blue. Properly prepared it is extremely fine and light, although minor differences in processing can easily lead to a harsh gritty product. The particle size is 1  $\mu$  or below, a substantial proportion of particles being colloidal. It possesses very high tintorial strength and is usually ground several times in oil to bring out its full strength. It has a very high oil absorption, 75-100%. Except in printing, it is generally used with other pigments, e.g., wlgtes, as it is so deep as to appear almost black. It is fast to light (see B.S. 283).

**Soluble Blue.**—Prussian blue is soluble in excess sodium ferrocyanide or oxalic acid, and soluble blues are made in this way. Ordinary writing ink used to be of this type, but of recent years the use of blue dyes has almost ousted the old-fashioned ink.

*Brunswick Blue* is a reduced quality of Prussian

blue, containing much barytes. *Celestial blue* is a still paler reduced blue. *Antwerp blue* is a mixed iron-zinc ferrocyanide blue.

#### GREEN PIGMENTS.

**Chrome and Brunswick Greens.**—Chrome greens are made from lead chromes and Prussian blue only, whereas Brunswick greens are further reduced with barytes or other extenders. Chromium oxide greens are quite different in every respect, and care should be taken to differentiate between chrome green and chromium oxide green.

Chrome greens provide a very wide range of shades. The palest greens are made from Prussian blue and primrose chromes. The middle and deep greens are usually made from lemon chromes, as the slightest trace of orange tends to produce bronze or quaker greens. For these, the deliberate addition of a trace of red oxide of iron or orange chrome, possibly with a trace of black, is resorted to.

The great difference in density between lead chrome (p 5-9) and Prussian blue (p 1\*95), as well as the very marked difference in particle size, leads to trouble termed "floating," whereby the blue floats to the top of the film during the drying of paints. This can be seen by drawing the finger across a film of green paint before it is dry, when a lighter strip will be left, which will gradually deepen provided the paint is not already almost dry. To avoid this trouble the utmost care must be taken to ensure thorough dispersion of the blue throughout the chrome, and complete wetting and dispersion of both pigments by the oil. Certain defects in the striking of greens tend towards "floating" and precautions are taken to avoid these as far as possible. Chrome and Brunswick greens are now mostly produced by dry grinding of chrome and blue. There still persists a prejudice against such greens and where a co-precipitated product is demanded the recommended procedure is to use only freshly struck blue, which is oxidised and washed, and the wash liquors decanted. The lead-salt solution is then added to the blue, when some adsorption of lead on the blue occurs, and prevents colloidal dispersion of the blue. The chromate solution is then run in and the mixture stirred for some hours before washing (see details of making chromes and Prussian blues separately). Excessive washing is to be avoided, but the presence of soluble salts is undesirable. As already mentioned under Prussian blue, only non-bronzing blues of greenish undertone should be used for the making of greens. Even the best greens will float when imperfectly ground in oils or varnishes, or when media of poor wetting characteristics are employed, and sometimes it is desirable to incorporate wetting agents in the media to be used.

∴ Chrome greens are very fast to light and have excellent weathering properties. Under some circumstances the blue may be destroyed first (e.g., by traces of alkali) in which case the green becomes yellower with age—this generally applies to the paler shades. Under other conditions the chrome may be decomposed, resulting in a bluer or blacker effect with age—this often

occurs with deep greens. They are, however, extensively used both for exterior and interior work and give excellent service. Occasionally a green paint will bleach in the tin—such paints may appear quite yellowish on opening, but when brushed out dry back to their correct shade. This defect is due to reduction of the blue to the white ferrous ferrocyanide, which is readily oxidised in air. It may be due to traces of acid left in the tin or to soldering fluid in the tin reacting with the metallic container and generating enough nascent hydrogen to reduce the blue.

Chrome greens are generally supplied in three shades, light, middle, and deep (Shades No. 25/26-27, British Standard. 3ML-1930). Brighter and lighter shades such as Brilliant Green No. 21, Grass Green, No. 18, Sea Green No. 17, and Eau de Nil No. 16 can be made from the above by the addition of suitable white pigments. The bronze greens and quaker greens require the addition of red oxide of iron or orange chrome. Brunswick greens are obtainable in the same wide range of shades as chrome greens. Owing to the great strength of chrome greens it is not necessary to employ them at full strength in all cases, and the durability of good quality Brunswick greens is quite satisfactory. The cheapest qualities are, however, often so far reduced as to give inferior service;

**Zinc Greens.**—Greens made from zinc chrome and Prussian blue are known as zinc greens. They may be obtained pure or reduced as mentioned above. They provide a brighter range of shades than chrome green, which is, however, more evident in the lighter shades, so that the range in shade is not so wide. They are fast to light but do not in general give such good service out of doors, nor do they possess the same obliterating power as chrome green.

As zinc chrome is not nearly so heavy as lead chrome, the objection to producing these greens by dry grinding does not hold, and they are in fact mostly prepared by this means. They are, of course, of value where for any reason the use of lead is prohibited, e.g., in spraying of paints, etc. They are alkali-sensitive owing to the presence of Prussian blue.

**Chromium Oxide Green, Cr<sub>2</sub>O<sub>3</sub>.**—Chromium oxide may be prepared by igniting ammonium or sodium dichromate, either alone or admixed with reducing agents, throwing into water and grinding, washing, filtering, and finally drying at high temperature to remove any water. Alternatively chrome alum or chromium salts may be precipitated with alkali and the precipitated hydrated chromic oxide washed and ignited. The product is substantially chromic oxide, Cr<sub>2</sub>O<sub>3</sub>, and as such it is resistant to heat, light, acids, and alkalis, and finds extensive use in the ceramic industry. It possesses a pleasing pastel shade unobtainable with any other pigment and is used in stoving finishes, e.g., for electric fires. It has good opacity when used alone, but its tinctorial strength is poor, so that it is not much used for the production of tints. In distempers, however, it is useful as it resists lime, but the lime greens (dyestuff) are considerably cheaper. It is also used for colouring cement and in rubber as it is quite un-

affected by sulphur (*see* B.S. 318-1938, included in B.S. 303-1938).

**Viriaia/i or Gulgnat's Green.**—Discovered by Guignet in 1899, this is a hydrated oxide of chromium  $\text{Cr}_2\text{O}_3 \cdot 2\text{H}_2\text{O}$ , prepared by fusing together potassium dichromate and boric acid and throwing the mass into water. It is a much deeper green than chromium oxide, being almost transparent in oil.

**Emerald Green.**—Known also as Schweinfurt or Paris green,\* emerald green is an arsenite of copper of the approximate composition  $7\text{CuO} \cdot \text{As}_2\text{O}_3 \cdot 3\text{CuAs}_2\text{O}_4$ . It possesses a delightfully clean and brilliant green colour unobtainable in any other way, and in spite of its poisonous nature is still occasionally used in paints. It also has considerable use as an insecticide. The pigment has good opacity but weak tintorial strength.

Scheele's Green is copper arsenite.

**Rinmarm's Green** is a zinc-cobalt green analogous to cobalt blue.

**Copper Greens.**—Malachite is a basic copper carbonate, formerly used as a green pigment. It should be clearly differentiated from Malachite Green, which is a basic dyestuff. *Oreen verditer* is a precipitated basic copper carbonate, no longer used.

*Verdigris* is the basic acetate of copper produced by the corrosion of copper in the presence of acetic acid. Its only use now is in anti-fouling paints.

**Green Earth** is a natural earth obtained from the neighbourhood of Verona, containing Glauconite, to which it owes its slight greenish colour. It is valueless as a pigment, but is used as a base on which to adsorb green basic dyes, notably lime greens (*see* *White* and *Green Earths under Extenders*, p. 629a; *see also* under *China Clay*, p. 6316, and *Lakes from Basic Dye-stuffs*, p. 646(2)).

BLACK PIGMENTS.

With the exception of black oxides of iron and ilmenite black, almost all the black pigments owe their pigmental properties to carbon. In the industry the term "carbon black" is reserved for one type of carbonaceous black, viz. that which is derived from natural gas of petroleum origin. In order to avoid confusion this may be termed gas black, but such a description is by no means generally accepted or adopted.

**Lamp or Vegetable Black** (v. Vol. II, 312a).—This pigment has been used for centuries, since long before the exploitation of petroleum, and was the purest form of carbon then available as a pigment. It was originally prepared by burning vegetable oil (rape or colza) by means of lamps in a limited supply of air and collecting the soot so produced. A similar black was prepared in China from China-wood oil or tung oil, and was used in the preparation of Chinese or Indian ink. The name is now applied to any black prepared in this way, and the materials used comprise the waste fractions rich in naphthalene from the distillation of coal tar, together with shale oils, crude mineral oils, and petroleum distillates; even fish oils have been used in the U.S.A. Resins produce coarse, sticky blacks. The best grades of black ore

obtained in furnaces of moderate size so built that the black is virtually calcined at the time of deposition and so carries with it little tarry or volatile matter. The collecting chambers are generally of brick, provided with baffles, so that the smoke has to travel several hundred feet before being vented to the atmosphere. The oil is burned in an iron dish some 4 ft. in diameter and 9 in. deep. The black may be refined by heating it in cast iron boxes, in the absence of air, in order to destroy any tarry matter and expel gaseous impurities, during which a loss in weight of 15-20% occurs.

The best qualities of lamp black are described as vegetable black, this being collected farthest away from the combustion end of the plant. It is blacker than common lamp black, and lower in ash and oily impurities. Neither vegetable nor lamp black is suitable for use in water paints, as owing to its slightly greasy nature it is not easily wet by water and is liable to separate badly. It is extensively used in oil paints, where its great strength and opacity together with its low density (1.7-1.8) and extreme fineness fill most of the requirements of a good pigment. Its colour is not so black as is that of gas black, being somewhat grey by comparison, and when reduced with opaque whites it produces greys of a bluish tint. It often contains an appreciable amount of oily matter, which together with the pronounced adsorptive properties of carbon, accounts for its tendency to retard the drying of paints. The particle size average 0.4  $\mu$  and the oil absorption is very high (90-440%).

**Carbon or Gas Black** (v. Vol. II, 3126).—This pigment is of more recent introduction, the first factory for its production being erected at New Cumberland, U.S.A., in 1872. It is made by burning natural petroleum gas in a limited supply of air by means of jets. The black so produced is condensed on a suitable surface, sometimes water cooled, of which a variety have been employed:

1. Steel channels (Channel Process).
2. Rotating discs.
3. Fixed plate under which the burners rotate.
4. Rotating rollers or cylinders.

Of these, the first two are most extensively employed. The reactions occurring during the burning of hydrocarbons in a deficiency of air have been studied by Bone (Phil. Trans. 1915, 215, 275), whilst the qualities of the various natural gases have been reported upon by the U.S. Bureau of Mines, Bulletin No. 192, 1922. The percentage recovery of the carbon content of the methane and ethane present in the gas is low—only 2.5-3% of theory.

**Channel Process.**—As some 90% of all gas black is made by this process, a brief outline will suffice. The gas is burnt from lava-tipped burners, accurately placed beneath steel channels which are provided with a reciprocating movement of 4-5 ft. Careful equalisation of gas pressure throughout, and accurate control of ventilation, are necessary to obtain optimum yield. Scrapers remove the black from the channels and drop it into hoppers, from which it is conveyed mechanically to bolting or sieving

machines, and is then packed in paper bags containing 12J lb. each.

Carbon black is much blacker in self-colour than vegetable black, and of very high staining power. When mixed with opaque white to form greys, the tint so obtained is brownish. The density is 1.8-2.1 and the oil absorption about 150%. The particle size is approaching that of colloidal dimensions, viz.  $0.1 \mu$ . Owing to the enormous surface of such finely divided pigment, marked adsorption of gases and moisture occurs. Carbon black is relatively easily wetted by water and may be used in distempers. It may, in fact, be differentiated from lamp black by the fact that merely shaking with water, carbon black is sufficiently wetted to mix with the water, whereas lamp black will not do so. When carbon black is mixed with oil, some qualities produce a paste which flows smoothly whereas others do not. They are termed "long" and "short" flow blacks—"long" blacks generally contain a large amount of adsorbed gases and a correspondingly low carbon content and can be converted into "short" blacks by heat or vacuum treatment.

Carbon black is extensively used by the rubber industry, where its effect on the mechanical properties of rubber is more important than its colour. Special grades of very small particle size are employed for this purpose, and the rubber industry ranks as the largest consumer, taking 70% of the total output. Printing inks (newsprint) accounts for a further 13% and the paint industry 10%.

**Thermatomic Black.**—This is produced by the cracking or pyrolysis of natural gases under pressure, by which method considerable economy is claimed, yields up to 30% of the carbon present in the gases being obtained. Thermatomic black is considerably more bulky than ordinary gas black, has a still higher oil absorption, and possesses a particle size of about 0.1  $\mu$ . It is chiefly used for rubber manufacture and is somewhat grey in colour. When reduced with whites it produces bluish-grey tints.

**Acetylene Black.**—This is produced from waste calcium carbide at Shawinigan Falls, U.S.A. The carbide is treated with water to produce acetylene, which is then exploded in a deficiency of air. As acetylene oxidises exothermically, relatively little heat is required and pressures of 50-100 lb. per sq. in. are employed. Acetylene black is inferior to gas black in colour and strength, reductions with white pigments being bluish-grey in tint.

#### Comparative Analysis of Various Blacks.

	Vegetable.	Lamp.	Carbon long.	Carbon short.	Thermatomic.
Ash	0.00	0.06	0.45	0.02	0.02
Moisture	0.39	3.2	3.56	2.25	0.02
Volatile matter	2.26	17.38	11.09	6.60	0.78
Carbon (fixed)	97.35	70.44	84.40	92.13	98.36
	10000	10000	10000	10000	10000
Density	—	—	1.80	1.85	—
B.S. Specification	286	287	284	284	—

**Bone or Ivory Black.**—Ivory black was originally made by the dry distillation of waste ivory chips. It is now regarded as synonymous with bone black. The bones are first degreased, and then boiled to extract the gelatin, after which the bones are submitted to destructive distillation in closed retorts. The residue contains 11 much calcium phosphate, on which is deposited carbon in a very fine state of division. Far from being a low-grade product, it is in fact the blackest of blacks, and is prized for the purity of its tone. Owing to the high content of ash, often as high as 80%, the low carbon content results in low tinctorial strength, and these blacks are accordingly not used to produce tints by admixture with white. Their principal use is in the production of de-l-black matt finishes, such as were used in old-time carriage decoration. Over this a black japan was applied, followed by two or more coats of varnish. In this way a depth of tone was obtained, which is absent from modern finishes. Bone black is used for black finishes, where a really black colour is desired. It has a much higher density than the blacks previously described, ranging from 2.6 to 2.8. By treating bone black with hydrochloric acid most of the calcium phosphate may be dissolved, when a very fine intense black remains. This is used in making the best grades of plate inks.

The bulk of the bone black made is used for the purification of molasses and for decolorisation generally.

**Drop Black.**—Originally, bone black used to be moistened with a little glue or gum and pressed through a perforated plate before drying. The separate pellets were considered proof of genuineness and freedom from adulteration with soot or other black. Although the practice has been abandoned the name persists and is used synonymously with bone or ivory black. According to Wilkins (Oil and Col. Trades J. 1924, 1165) much of the bone or drop black used as pigment consists of spent animal charcoal used in decolorising molasses. It was ground and washed, and it was this material, which when pressed through perforated trays to form "drops," was sold as drop black.

**Graphite** (v. Vol. II, 313d).—Deposits of plumbago or black lead occur in Cumberland, where they are used in the making of lead pencils. Similar deposits occur elsewhere, presumably from the action of terrestrial pressure and heat on organic deposits rich in carbon. Graphite is a form of carbon, crystallising in the hexagonal system, characterised by perfect cleavage parallel to the basal pinacoid. It occurs in figures in Ceylon, Irkutsk, and Borrodale, as bedded lenticular masses in gneiss in Canada, and as disseminations through country rock in the neighbourhood of veins in Germany, Austria, U.S.A., and elsewhere.

It is the nearest approximation to diamond in composition, yet it is extremely soft by comparison and possesses a greasy feel. It makes an excellent lubricant and is also capable of taking a pronounced polish. As a pigment, it is used in conjunction with carbonaceous blacks to make graphite paints, used principally on metal chimney and other surfaces "required to with-

stand great heat. \*Its water repellent properties probably account for its vogue as an anti-corrosion pigment, graphite in contact with steel generally acting as a stimulator of corrosion. Graphite is now manufactured from anthracite by heating in an electric furnace, and is extensively used for the making of crucibles, electrodes, lead pencils, and as a solid lubricant. It has only a limited application as a pigment.

Mineral Blacks.—A number of deposits of carbonaceous earths\* are worked, some of which have a limited use as pigments, the best known in this country occurs at Bideford, Devonshire, where a seam about 2 ft. in thickness outcrops near the river. The best grade contains as much as 69% of carbon, the lower grades being used as fillers, etc?

Comparative Data for High-ash Blacks.

	Ivory.	Bone.	Vine.	Mineral.	Iron oxide.
Ash . . .	75-85%	70-85%	95%	0-60%	100%
Carbon content	15-25%	5-25%	3-5%	15-50%	Nil
B.S. Specification	285*	285	(None)	288	306

Black Oxides of Iron.—Micaceous iron ore, Fe<sub>2</sub>O<sub>3</sub>, and magnetic oxide of iron, Fe<sub>3</sub>O<sub>4</sub>, are both used to a limited extent as black pigments. They may with advantage be used in conjunction with carbon black or graphite where the latter is liable to burn away, as on exhaust manifolds, fire grates, etc. (see Oxides of Iron, p. 633a).

Ilmenite Black.—Ilmenite or titaniferous iron ore, FeTiO<sub>3</sub>, was introduced by J. W. Ryland of Birmingham in 1865 and has a limited use as a pigment. It is not so heavy as oxide of iron and is free from any tendency to "float" like carbon blacks.

Cobalt Black, CoO, is used in the pottery industry but its price is prohibitive for general paint use.

Manganese Dioxide, MnO<sub>2</sub>, has been used as a pigment for colouring cements, but is chiefly used as a drier.

METALLIC PIGMENTS.

In the application of gold leaf to an adhesive coat of gold-size the gold fulfils the function of the pigment but can hardly be described as such, although it is perhaps the most effective use of metal for the purpose of decoration. Metals in the form of powder or flakes are used, but with the possible exception of aluminium, not extensively.

Aluminium.—Aluminium powder is manufactured from the waste, obtained in the production of foil, by further stamping, until it is reduced to powder. The metal is coated with stearic acid, to prevent the particles adhering together, and polished by the action of brushes in a revolving cylinder (v. Vol. 1,278c, for further details). The product is graded as to lustre and fineness, and consists of thin platelets about 2 microns, in thickness and from 50 to 100

microns in diameter. It has good opacity and a distinctive hue, and when suspended in a suitable medium the platelets float and become orientated parallel to the surface to which they are applied. This is termed "leafing" and results in a high degree of reflection of light or heat and a corresponding low degree of absorption or radiation. Hence aluminium paints are commonly used on large storage tanks, roofs, etc., in order to maintain a more equable temperature within during hot weather, and may be used to minimise heat losses on piping and tanks of hot water heating systems. It is a mistake, however, to paint radiators with aluminium paint as this reduces the amount of radiation—dark matt surfaces provide greatest radiation. Aluminium, generally in association with other pigments, is also used in primer coats to reduce permeability to moisture. Added to shellac solutions or "knotting," it is used as a sealer coat to prevent the "bleeding" of oil-soluble stains and dyes through subsequent coats of paint. Aluminium powder can be used in oil varnish, damar or other resinous media, cellulose lacquers or even water media. The choice of the medium must be made with care, and it is generally recommended that the powder be stirred in immediately before use, to obtain the brightest results. On keeping, such paints gradually dull, although ready mixed paints are on the market (see B.S. 388-1938, which includes a method of evaluating leafing properties (Appendix F)).

Coloured aluminium powders are also available, in which the aluminium has been stained or coloured by means of basic dyes fixed by suitable agents, usually tannic acid.

Aluminium paste is now made, in which the powder is dispersed in white spirit. Such pastes, containing about 60% aluminium powder, may be used in place of the dry powder in any medium with which the white spirit is miscible, and have the advantage of reducing the dust problem. Further, substitution may be made pound for pound, as the paste form is so much more easily and effectively dispersed that equal covering is obtained.

Copper Bronze.—Known popularly as "Gold Powder," a whole range of bronze powders of various hues and fineness are available. Apart from their higher specific gravity, they can be used in just the same way as "silver" or aluminium powder, in all media they are liable to develop a green colour due to the presence of copper.

Zinc.—Zinc powder in the form of a fine grey powder containing 98% Zn has been employed as an anti-corrosion pigment. The particles are not flat and do not leaf like aluminium, settling out rather badly.

Lead.—Lead powder has good anti-corrosion properties, but is even more difficult to keep in suspension, and is little used.

LUMINOUS PIGMENTS.

# Luminescence and fluorescence are\* treated fully elsewhere (v. Vol. VII, 2016, #405; Vol. VIII, 20-45) and only brief reference need be made here.



Fluorescent pigments are those which glow only so long as they are subject to illumination from some independent source (*e.g.*, an ultra-violet lamp), whereas phosphorescent pigments continue to glow after irradiation has been withdrawn, the period of after-glow varying widely, but amounting to 8 hours or more in some cases.

Fluorescent pigments may be used for the coating of the interior of gas-discharge lamps in order to modify the characteristics of the light emitted (*e.g.*, daylight lamps) as well as for the preparation of signs of various types, which can be illuminated by concealed lamps. The following are some of the materials so employed: uranium salts, cadmium borate or chlorophosphate, calcium or magnesium tungstate, zinc or beryllium silicates, etc.

Phosphorescent pigments are generally composed of the sulphides of zinc or cadmium, together with the carbonates of the alkaline earths. The presence of suitable phosphorogens, *e.g.*, manganese, copper, or certain of the rare earths is desirable, but the exclusion of iron, lead, and other inimical impurities is essential. The above materials together with sulphur and a suitable flux, after heating at 800-1,000°o. under reducing conditions and cooling rapidly out of contact with air, are lightly powdered to produce a coarse crypto-crystalline product. The light emitted varies from red to violet and depends both on the main components and on the phosphorogens present, as well as on the care with which the whole process is controlled.

Radioactive pigments containing mesothorium or similar materials to the extent of 0.0001% are practically self-activating and are commonly used on the hands of clocks and instruments required to be visible at night. Care in the application of such materials is essential, in order to prevent operators absorbing radioactive components in any way.

As might be expected, these materials are extremely sensitive to moisture and to the media used for application. In general, oils and oil-varnishes seriously decrease the luminosity, solutions of resins or even aqueous media being preferred. Still better results are obtainable by dusting the materials on to a tacky film, but unless some protection is afforded against moisture and dirt retention, rapid deterioration is inevitable. They have also been used successfully in conjunction with plastics.

#### LAKES FROM NATURAL COLOURING MATTERS.

The number of natural colouring matters used in pigments nowadays is very small and are more of historical interest than practical importance.

The two mainly used to-day are Carmine from the cochineal insect, *Coccus cacti*, *v.* Vol. III, 226, and Logwood lake from the vegetable colouring matter of the wood of the Logwood and Campeachy trees (*v.* Vol. VII, 378a). The latter is also used extensively in the textile industry.

Others that may be used occasionally are Dutch Pink (actually yellow) from quercitron bark, Hose Madder from the natural madder root (*v.* Vol. VII, 435(2)) and Sepia from the ink bag of the cuttle fish, they all having a small use in artists' palettes.

Carmine (*v.* Vol. III, 226(2)) is the aluminium salt\* of carminic acid obtained by boiling the cochineal insect with water and throwing-out the insoluble lake by the addition of solution of alum. It is used in foodstuffs, cosmetics, and particularly the colouring of tooth-paste and dental plates. It is impossible at present, with lakes from coal-tar dyestuffs, efficiently to displace it. Carmine is insoluble in water but dissolves to a bright crimson in ammonia.

Logwood Lakes (Vol. IV, 126a; VII, 378a).—Logwood extract is generally used rather than the logwood chips previously available. The extract is dissolved in water and the colour developed in the presence of chromium and iron by boiling with an oxidising agent, usually potassium\* dichromate on a base of aluminium hydroxide. It yields purple to black lakes, the blacks being prized for their depth of blackness, making pigments such as gas-carbon black and bone black look grey by comparison. The lakes have fairly good fastness to light but poor opacity and staining power ("The Chemistry of Natural Colouring Matters," F. Meyer, trans, by A. H. Cook, Reinhold Publishing Corp., New York, 1943).

#### CHEMICALLY PREPARED PIGMENT\*\* AND LAKE COLOURS.

The definition of a lake given earlier does not separate very easily any specific group of pigments formed from coal-tar dyestuffs and intermediates, consequently the divisions in this article have been made by the method of manufacturing the insoluble pigment or lake. The reader will be referred as far as possible by cross reference to the Dictionary when specific dyestuffs or groups are discussed. The division, although not scientific, simplifies the grouping of dyestuffs and intermediates chiefly used by the pigment manufacturer as, of the many available, relatively few are satisfactory for lakes and pigments, the bulk being used in dyeing.

Properties of Lakes and Pigment Dyestuffs.—In the inorganic pigments, properties such as light fastness, oil solubility, acid, alkali, and heat resistance are common to the specific pigment, and although slight variations may occur due to the method of manufacture (such as lightfastness of lead chrome) the variation is within fairly narrow limits. This does not apply to the organic colouring materials, as it is possible by modifying the process of preparing the insoluble lake or pigment to alter considerably such properties as shade, lightfastness, oil, and water solubility. As an illustration, Methyl Violet (a water soluble basic dyestuff, C.I.680) can be laked by precipitation with tannic acid, oleic acid, benzoic acid, and the complex acids phosphomolybdic and phosphotungstic, and the properties of the various lakes are modified considerably.

*Lightfastness.*—It is extremely difficult to make comparisons of this property, and the one in general use to-day "Comparison with Madder Lake," although reasonably satisfactory, leaves much to be desired. There are a number of factors that influence the light fastness, such as the medium in which the pigment is exposed,

the strength of the pigment and the amount present per unit area, the composition or the other materials in the mix, humidity, and quality of atmosphere, etc. For this article the fastness of Madden Lake is taken as 10, and comparisons made against that figure (K. Mackenzie-Riffhard, J. Oil Col. Chem. Assoc. 1944, 3).

**Fastness to Oil.**—Some lakes and pigment dyestuffs are completely insoluble in drying oils, whilst others bleed very slightly and some bleed quite badly. If a film containing a pigment that bleeds is overcoated or lined with a white there is a danger that the white will be coloured by the bleed. Acidity of media, type of resin and solvent used all affect this property. In the charts following, fastness to solvents, water, alkali, and fat are given but they are merely comparative and should be accepted with caution, i.e., fastness to alkali would be the ability of the pigment to withstand the free lime in a plaster, and does not refer to caustic alkali (H. Jones, "Organic Colours for Rubber," J. Oil Col. Chem. Assoc. 1940, 244).

**Variation in Shade and Strength of Dyestuff.**—Very often the dyestuff manufacturer markets a range of shades and strengths in one dyestuff. The strength is indicated by figure\* such as Tartrazine 200 which means that it is 200% or double the strength of the original standard and the shade or tone is indicated by various initials, showing, in the case of a green or red, blueness or yellowness. Unfortunately, particularly in the case of strength, there is little relationship between the various manufacturers' figures, and the lake maker generally standardises before laking.

**Division\* According to Manufacturing Process.**

A. **Pigment Dyestuffs.**—From colourless intermediates requiring diazotisation and coupling (v. Vol. IV, 234).

1. Those forming complete pigments in themselves and require no further processing other than, if necessary, reducing with an extender.
2. Those consisting of insoluble or sparingly soluble acid dyestuffs, usually in the form of their sodium salt, and requiring further processing with a metallic salt to convert them into lakes.

B. **Lakes from Acid Dyestuffs** (v. Vol. IV, 203).—The primary colouring matters of this group are soluble dyestuffs containing salt-forming groups (sulphonic or carboxylic) and are converted into insoluble lakes by precipitation with metallic salts, often requiring a base or substratum to complete precipitation. Where a base is not present they can be termed "toner lakes."

C. **Lakes from Basic Dyestuffs.**—The primary colouring matters are soluble dyestuffs containing salt-forming groups (usually amino) that are converted into lakes by a certain acid—many requiring a base or substratum for complete precipitation. Where a base is not present they can be called "toner lakes."

D. **Derivatives of Anthraquinone** (v. Vol. 1,387).—In this division the mordant and vat dyestuffs will be considered, the sulphonated anthraquinones being dealt with under acid dyestuffs.

Those that do not fall easily under the above headings will be considered at the end.

**Lake Bases.**—In certain instances it is essential to have a base or substratum present to obtain complete precipitation of the dyestuff and/or obtain the required pigmentary properties. A number of the reducing whites already discussed are sometimes used, acting as dispersers of the precipitated dyestuff, but generally a precipitated white, such as aluminium hydroxide, is used which takes part in the reaction and assists precipitation. The whites named below may be present in a lake.

**Aluminium White** is usually described as  $Al_2(OH)_6$  but varies in its content of basic aluminium sulphate and in its chemical and physical properties according to the particular method of manufacture. An average formula would be 5 parts soda ash dissolved and added to 10 parts of aluminium sulphate. Concentration of solution, temperature of precipitation, and a variation in the amount of soda ash all contribute their part in the properties of the finished base. Potash, soda, and ammonia alum can be substituted for the aluminium sulphate, and caustic alkali for the soda ash.

The following show the various stages of precipitation as the soda ash runs into the aluminium sulphate:—

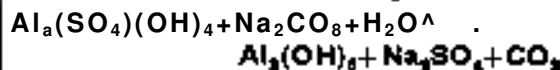
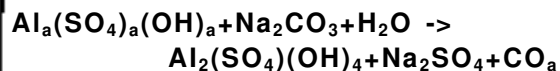
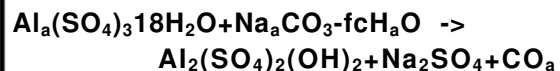

The formation of basic sulphate is favoured by using cold dilute solutions. After precipitation the base is washed and is then ready for lake making.

**Alumina Blanc Fixe**,  $Al_2(OH)_6 \cdot BaSO_4$ .—If the aluminium hydroxide as prepared above is not washed, but a solution of barium chloride added, barium sulphate is precipitated in intimate association with the aluminium hydroxide. Advantage of this is often taken when acid dyestuffs are to be laked, in which case the dyestuff is dissolved and added to the aluminium hydroxide before washing, and sufficient barium chloride added to precipitate both the dye as the barium salt and the sulphate as barium sulphate.

**Satin White** is a mixture of calcium aluminate and calcium sulphate and used for the preparation of pulp colours for paper surfacing work. It is prepared from calcium hydroxide and aluminium sulphate by double decomposition.

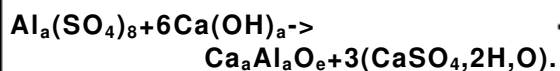

Its use is restricted by the fact that many barium lakes cannot be precipitated onto it owing to reaction taking place between them and the calcium sulphate.

Other precipitated whites used are aluminium phosphate, blanc fixe, and to a lesser extent aluminium arsenite and aluminium silicate.

Although certain dyes will precipitate without the presence of a base, others require a base. There is an optimum amount of dye that will precipitate, extra dye often reducing the brilliancy and strength of the lake. The average lake would contain 10-20% dye but as the dye-stuff itself varies in strength this might vary considerably.

**A. Pigment Dyestuffs. Sub-section 1.**—This group probably contains the most important members of the organic pigments derived from coal-tar intermediates and a wide range of shades is available. They are mainly azo pigments where the diazotisation of an amine and the coupling with other substances, mainly phenols and naphthols, produce an insoluble pigment dyestuff which, after washing, drying, and grinding, can be used without further processing.

For diazotisation and coupling, v. Vol. IV, 195.

The nomenclature generally of organic dyestuffs and the pigments and lakes made from them requires standardising, as most pigment manufacturers have their own trade names and are not always prepared to divulge the particular couplings. For the purposes of this article the generally accepted name will be used and wherever possible the number in the colour index given (F. M. Rowe, "Colour Index," Society of Dyers and Colourists, 1924).

The following are a few of the more important pigments falling in this group.

No. in  
Colour  
Index.

- 69 Helio Fast Scarlet: 3-nitro-4-toluidine +/?-naphthol.
- 44 Paranitraniline Red YS: 4-nitroaniline +j8-naphthol.
- Paranitraniline Red BS, about 10% of the j8-naphthol is substituted by 2-naphthol<sup>17</sup>-sulphonic acid.
- Permanent Red R: 2-chloro-4-nitroaniline+0-naphthol.
- Permanent Red 2G: 2: 4-dinitroaniline +/)-.aphthol.
- Permanent Red F4RH: 5-chloro-2-toluidine+chlorotoluidide of j3-hydroxynaphthoic acid.
- Hansa Yellow Gb: 3-nitro-4-toluidine -) acetoacetanilide.
- Hansa Yellow 5G: o-nitroaniline+acetoacetanilide.
- Hansa Yellow 10G: p chloro-o-nitroaniline+ acetoacet-o-chloroanilide.
- Benzidine Yellow: dichlorobenzidine 4-acetoacetanilide.

	Fastness to light.	Fastness to oil.	Fastness to alkali.	Fastness to heat.	Fastness to cellulose solvents.	Fastness to water.
Helio Fast Scarlet	10	Good	Very good	140°C.	Poor	Insoluble
Paranitraniline Red	7	Poor	"	120°C.	"	"
Permanent Red R	10	Good	"	130°C.	"	"
Permanent Red 2G	10	"	"	150°C.	Fair	"
Permanent Red F4RH	10	Poor	"	140°C.	"	"
Hansa Yellow: G	10	Good	"	130°C.	Poor	"
5G	10	"	Poor	120°C.	"	"
10G	10	"	Very good	120°C.	"	"
	c					

**A. Pigment Dyestuffs. Sub-section 2.**—In this group, after diazotisation and coupling, the sodium salt formed is insoluble or sparingly soluble in water and although often used in this condition for printing inks, plastics, and rubber, further processing with barium, calcium, strontium, or zinc modifies the properties of the pigment, particularly the tone and fastness to light.

Considerably increased strength can be obtained by adding, during the laking process, suitable dispersive agents, notably rosinate. Sodium rosinate can be added to the suspension of the sodium salt of the dyestuff and on the addition of calcium chloride the calcium lake of the dyestuff is formed together with calcium rosinate. It is then boiled to obtain full depth of shade, washed and dried. These highly dispersed lakes are useful for certain purposes, but exhibit thickening properties when used with acidic media, and have a tendency to bleed more freely than the normal calcium or barium salt.

The following are typical of this group:

*Lithol Red R* (C.I. 189).—2-Naphthylamine-1-sulphonic acid+/?-naphthol.

Calcium or barium salt generally used, the calcium being bluer and rather duller than the barium; for very yellow shades zinc can be used, but gives very little advantage over the sodium salt used alone.

*Lake Red C* (C. J. 165).—6-Chloro-3-toluidine-4-sulphonic acid+j9-naphthol.

Barium salt used and known as Bronze Scarlet when made in full strength.

*Lithol Rubine BN or 4B* (C.I. 163).—4-Toluidine-3-sulphonic acid+j9-hydroxynaphthoic acid.

Laked as barium or calcium salt, the latter being known as Lithol rubine BKN or Lithol rubine 4B toner.

.PROPERTIES.

	Fast-ness to light.	Fast-ness to oil.	Fast-ness to alkali.	Fast-ness to heat.	Fast-ness w cellulose solts.	Fast-ness to water.
LitholRed A. Ba Lake? Red lake*	5	Good	Good	100°C	Good	Insoluble
Lithol Rubine 4B. Ca salt.	3	ii	ii	150°0.	ii	ii
	0	ii	ii	150°c.	ii	ii

B. Lakes from Acid Dyestuffs.—Many dyestuffs from\* various chemical groups fall under this heading. Some like Pigment Scarlet III B. (C.I.216) and Ponceau Scarlet (C.I.79) are azo dyestuffs which after diazotisation and coupling are soluble in water. Representatives from the pyrazolone, thiazole, nitroso, xanthene, anthraquinone, and phthalocyanine dyestuff groups are also found, their common factor being that they are soluble in water and can be precipitated by a salt of barium, calcium, or aluminium, giving an insoluble compound with good pigmentary properties.

Except in specific instances, such as Eosin (Vol. IV, 316) and the nearly related phloxine, erythrosine, and Rose Bengal, the acid dyestuffs require a base or substratum to be converted into true lakes (see Lake Bases, p. 643c). Aluminium white is probably the most common. A tartrazine lake can be taken as a typical illustration of the method of manufacture. The base is first made by the addition of soda ash to aluminium sulphate and is well washed. The dye is then dissolved and added to the base followed by a solution of barium chloride. This lake, termed a "lacquer lake" because of its transparency, is used by printing-ink manufacturers for tin printing inks.

Another example is Ponceau Scarlet (an acid azo dyestuff soluble in water).

Here the aluminium white is made but not washed, and a solution of the dye added; sufficient barium chloride is then added to precipitate the dye as the barium salt and the soluble sulphate as blanc fixe.

The following are a few dyestuffs commonly laked by the above methods; the list indicates the varied types of dyestuff for which the above methods of laking are suitable.

	No. in Colour Index.
Tartrazine (pyrazolone)	640
Ponceau Scarlet (sulphonated azo dyestuff)	79
Soluble copper phthalocyanine (sulphonated phthalocyanine)	—
Alizarine Cyanine (sulphonated anthraquinone) (v. Vol. I, 206)	1,063
Alkali Blue (sulphonated triphenyl pararosaline) (v. Vol. I, 2336)	704
Naphthol Green (nitroso)	5
Eosin (tetrabromofluorescein) (v. Vol. IV, 316)	768

A special brand of Alkali Blue is made for the production of "Reflex Blue," a toner lake used by printing-ink manufacturers for tinting blacks and printing blues with a high sheen.

The Eosins are among the few soluble acid dyestuffs that will precipitate completely without the presence of a base. The precipitating agent is usually lead nitrate or acetate and the "toner lake" thus formed is called "Bronze Red."

PROPERTIES.

	Fast-ness to light.	Fast-ness to oil.	Fast-ness to alkali.	Fast-ness to heat.	Fast-ness to cellulose solvents.	Fast-ness to water.
Tartrazine. Balake	Poor	Good	Good	100°c.	Poor	Fair
Ponceau. Balake	ii	ii	ii	100°c.	ii	ii
Cu Phthalocyanine. Balake	9	ii	ii	120°c.	Good	Good
Alizarin cyanine. Balake	10	ii	ii	100°c.	ii	ii
Alkali Blue. Reflex Blue lake	Poor	ii	ii	100°c.	Fair	ii

An insoluble pigment can be made by precipitating a basic dyestuff with an acid dyestuff. Only a very few combinations are satisfactory, one of the most important being Methylene Blue (C.I.922) as the basic dyestuff, and Alizarine Cyanine (0.1.1063), as the acid dyestuff. This gives an insoluble blue lake with good fastness to light, lime, and water.

C. Lakes from Basic Dyestuffs.—Here the soluble dyestuff is precipitated by a weak acid and until the advent of the complex acid precipitations (phosphotungstic and phosphomolybdic) the lakes generally were considered to be brilliant but fugitive. The basic dyestuffs used in lake making are few in number compared with the acid dyestuffs but they are characterised by their great strength and brilliancy. The following six are the most important and the total used for producing lakes would probably not be more than fifteen.

	Colour Index.
Methyl Violet—triphenylmethane group	680
Victoria Blue—triphenylmethane group	729
Malachite Green — triphenylmethane group	657
Brilliant Green — triphenylmethane group	662
Auramine—Ketonimine group	655
Rhodamine—Xanthene group	749

They can be laked by the precipitation of the dyestuff in the presence of aluminium hydroxide or phosphate as:

- tannates, using tannic acid;
- rosinates, using sodium rosinat;
- benzoates, using benzoic acid;

and other methods such as using Turkey Red oil (sulphonated castor oil), silicates, arsenite,

etc., and in the absence of a base by the complex-acid precipitations.

The following are formulae for laking the basic dyestuffs with different precipitating agents. It will be appreciated that considerable variation is possible in the method, but the illustrations are typical.

*Tannic Acid.*—Dissolve 15 parts of soda ash and run into 30 parts of aluminium sulphate. Wash the aluminium hydroxide so formed and add 1 part basic dyestuff as 1% solution. Then dissolve 1 part tannic acid and 1 part sodium acetate and add to the above slowly with constant stirring. On examination the dye will be found to be fixed on the base and the lake can be washed and dried at a low temperature.

The sodium acetate is present as a buffer, as the dyestuff is usually in the form of its hydrochloride and releases hydrochloric acid when reacting with the tannic acid.

*Benzoic Acid.*—1 part basic dyestuff dissolved and added to 7 parts aluminium sulphate. Then dissolve 9 parts sodium benzoate and add slowly, when the dyestuff will be precipitated on to a base of aluminium benzoate precipitated simultaneously. Wash and dry at a low temperature. Sodium silicate can be substituted for the benzoate.

*Complex Acid.*—1 part basic dyestuff dissolved and the following solution added: 2 parts sodium tungstate, 0.5 parts sodium molybdate, 0.5 parts sodium acid phosphate. After precipitation, raise to boil and wash free of soluble salts and dry.

The basic dyestuff lakes (other than the complex acid precipitations) generally have poor fastness to light, are brilliant, and used mainly by printing-ink manufacturers for purposes where their fugitive character does not matter.

Considerable increase in fastness to light as well as complete precipitation of the dye in the absence of a base can be obtained by the use of phosphotungstic and phosphomolybdic acid. To obtain the maximum strength, fastness to light and insolubility in oil, each dyestuff requires varying proportions of the complex acids, and considerable work has been done on this type of precipitation during the past thirty years.

*Green-earth Precipitations.*—A series of lakes can be prepared without further precipitating agents by the addition of a solution of the basic dye to green earth (terra verte) (v. Vol. VI, 136). Probably due to the high percentage of ferrous silicate in the green earth the dyestuff is fixed to the extent of 10%, and the resultant lakes, particularly those made with Auramine, Brilliant Green, and Victoria Blue, make a wide range of shades of lime greens used to a large extent in the cheaper types of distemper.

D. Derivatives of Anthraquinone- (v. Vol. T, 387).—These can conveniently be divided into three groups:

1. Adjective dyestuffs where the colour is developed in the presence of a mordant. Alizarins (v. Vol. I, 203).

2. Sulphonated and rendered water-soluble and dealt with under acid dyestuffs (w. Vol. 1, 210).
3. Vat dyestuffs (v. Vol. I, 208).

*Group 1.*—The alizarins (hydroxyanthraquinones) are the most important. They are generally termed Madder Lakes and in the main are the aluminium salts of alizarin. In practice it is found that aluminium alone does not give altogether satisfactory results and it is necessary to have present calcium salts, phosphates; and Turkey Bed oil (sulphonated castor oil). The alizarins, of which a number, of shades are available, are generally sold to the colour maker as a 20% paste with water.

The method of manufacture is to make an aluminium phosphate-white and, after washing, to add the alizarin (either as a paste or dissolved in soda ash) together with calcium chloride and Turkey Red oil. The suspension is then brought slowly to the boil and kept boiling until maximum brilliancy is obtained.

The crimson alizarin (mainly 1:2-dihydroxyanthraquinone) is the most important, but other shades containing varying hydroxyl groups are available as Scarlet, Orange, and Bordeaux. The addition of salts of iron, manganese, and copper are used to modify the tone.

The madders are characterised by their good fastness to light and insolubility in most media, but they have poor opacity and are not particularly strong.

*Group 2.*—See Group B, Lakes from Acid Dyestuffs, p. 645a.

*Group 3.*—Characteristic of the vat dyestuffs is their property of being converted, through the action of alkaline reducing agents, into soluble hydro-compounds possessing affinity for vegetable and sometimes animal fibre. These absorbed hydro-compounds are fixed in the fibre by subsequent oxidation, which usually takes place on exposure to air, whereby they are reconverted to the original insoluble dyes.

Only a few are satisfactory as pigments, Indanthrene Blue (C.I. 1M5) being a typical example. They have not made any great headway for the production of lakes, owing chiefly to their very high cost, low staining power, and lack of brilliancy, and, although as textile colours they are renowned for their extreme fastness to light, they have not shown this property in lakes to such a marked extent.

For the preparation of pigments the dyestuff is simply mixed with the substratum. Although it is possible to reduce and then reoxidise in the presence of the substratum, giving, of course, intimate distribution throughout the base, the method is not altogether successful.

*Other Pigment Dyestuffs.*—The following do not fall easily under any of the foregoing groups:

*Nitroso Compounds* (see also Naphthol Green, an acid dyestuff).—Of the insoluble types, only one is of any interest, Pigment Green B. It is insoluble when made in oil and water with good fastness to light, good strength and excellent resistance to lime.

It is manufactured by the addition of ferrous sulphate to a solution of the bisulphite compound

of 1-nitroso-2-naphthol, being related to the acid dyestuff Naphthol Green, which is soluble in water and dealt with under acid dyestuffs (F. M. Rowe, J. Ind. Col. Qiem. Assoc. 1938, 189).

*AnilinoBlack* (Vol. II, 137a).—Produced by the oxidation of aniline hydrochloride with hypochlorites or dichromate, copper salts sometimes being present (Colour Index 870).

It has good fastness to light and is insoluble in oil and most organic solvents. It has a jet black mass tone, \* very high oil absorption, and poor opacity.

*Phthalocyanines* (see this Vol., p. 617c).—This group gives to the pigment user some excellent greens and blues. At present there are four important members:

1. Copper phthalocyanine . . . . . Blue.
2. Chlorinated copper phthalocyanine . . . . . Green.
3. Metal-free phthalocyanine. . . . . Greenish-blue.
4. Sulphonated copper phthalocyanine (soluble in water and dealt with under Group B, Lakes from Acid Dyestuffs, p. 5a).

Characterised by resistance to treatment with dilute hydrochloric acid or caustic alkali, insolubility in organic solvents, excellent resistance to heat, and fastness to light, they have found an important place in practically all colour-using industries. Mixed with yellows (lead and zinc chrome, Hansa yellow) a fine range of greens can be produced (M. H. Maddick, "Phthalocyanine Colouring Matters," J. Soc. Dyers and Col., May, 1946).

*Bibliography.*

J. J. Pittelli, "Protective and Decorative Coatings," Vol. 2, New York, John Wiley & Co., 1941.  
 F. A. Walker, "Dyestuff Pigments for Paints," J. Oil Col. Chem. Assoc., 1947, 91.  
 A. W. C. Harrison, "The Manufacture of Lakes and Precipitated Pigments," Leonard Hill, London, 1930.  
 J. J. Fox and T. H. Bowles, "Analysis of Pigments, Paints, and Varnishes," Benn, London, 1927.  
 Noel Heaton, "Outlines of Paint Technology," 3rd ed., Charles Griffin, 1947.

T. D. K. and H. L. H. PIMENTO. The dried full-grown but unripe fruit of *Pimento officinalis* Lindl. (Fam. Myrthaceae), indigenous to the West Indies, though largely cultivated in Jamaica, whence our supplies are derived, and to a lesser extent in Central America. The plant is an evergreen tree rising 25-40 ft. in height with an erect trunk and a round-topped crown. It bears small white flowers with inferior two-celled ovaries. The sub-globular berries are 4-8 mm. in diameter with four small calyx teeth at the apex forming a minute ring. The fruit is generally two- but occasionally three- or one-celled, and differs in this respect from cloves, in which one seed only develops. The fruit is gathered while still green, but soon turns purple in the sun and becomes brown and warty on drying. The characteristic flavour is due to the presence of from 2 to 6% of volatile oil and on account of its resemblance to a mixture of clove, cinnamon, and nutmeg, pimento is commonly called allspice. The pericarp is woody, brittle, and about 1 mm. thick and contains numerous oil glands. The seeds are blackish-brown in colour, plano-convex, and slightly roughened

and shiny on the outside, and are separated by a thin papery layer. Its chief use is as a condiment and to a lesser extent as an aromatic stimulant and carminative, but its use in medicine is diminishing and it is no longer official in the pharmacopoeias.

*Microscopic Appearance.*—The chief structural components of the ground fruit are (1) the small polygonal cells and stomata of the outer layer of the pericarp with short, thick-walled hairs, under which are the oil cavities in the parenchyma, and (2) the minute starch grains of the embryo, mostly in pairs or triplets, but sometimes single, and usually about 8µ and not exceeding 12µ in diameter with a distinct hilum. Other characteristics are the abundant lignified sclerenchymatous cells of the pericarp, the conspicuous port-wine coloured parenchymatous cells of the spermoderm, and the ground parenchyma of the embryo containing volatile oil cells and starch grains. Owing to the dark colour it is preferable to extract with alcohol and sodium hydroxide before examination.

*Chemical Composition.*—The most important constituent is the essential oil, which is best determined by the method of Cocking and Middleton (Quart. J. Pharm. 1935, 8, 435). The powdered fruit is mixed with brine, distilled, and the vapours passed through the top of a condenser into a graduated tube, in which the oil is collected whilst the condensed water is returned to the distillation flask. An air inlet and outlet is provided by means of a side tube below the condenser, but above the graduated tube. As pimento oil is heavier than water a small quantity of turpentine oil is distilled with water in the apparatus before the spice is added, the volume of the turpentine fraction is read and this is subtracted from the final volume of the oil. Cocking and Middleton found that the yield of oil is increased slightly by powdering the fruits before distillation, but that the powdered drug loses oil on storage. For further details of the oil, v. Vol. VIII, 660\*.

The following table gives the composition of pimento fruits, as found by numerous workers (Richardson, U.S. Dept. Agr., Div. Chem. 1887, Bu. 13, 11, 227; Winton, Ogden, and Mitchell, Connecticut Agr. Exp. Sta. Rep. 1898, 184; Arragon, Ann. Falsif. 1915, 8, 345; Inland Rev. Dept. Canada Bull. 1917, No. 403) and the author:

	Max. %	Min. %	Average %
Water . . . . .	11.3	5.5	0.7
Ash . . . . .	8.2	3.4	4.4
Ash, soluble in water . . . . .	2.7	2.3	2.5
Ash, insoluble in HCl . . . . .	0.1	0.0	0.05
Essential oil . . . . .	6.0	2.0	4.2
Starch . . . . .	7.7	3.7	5.8
Starch (diastase) . . . . .	3.8	1.8	2.0
Starch, crude . . . . .	22.5	16.5	20.0
Protein . . . . .	6.9	4.0	5.8
Fibre . . . . .	24.0	13.4	22.4
Tannin, crude . . . . .	12.8	8.0	0.7
Alcohol extract . . . . .	14.3	7.4	11.8

W. L. Brown (Georgia Agric. Exp. Sta. Bull. 1930, No. 160) found that the addition of pimento to poultry rations increases the pig-

mentation of the shanks, comb, and wattles, the effect being more pronounced in cockerels than in pullets. L. Ascham (Science, 1933, 77, 351) found pimento to contain over 1 unit of vitamin-A by the rat test.

**Standards.**—The United States standard for allspice provides that the quercitannic acid shall not be less than 8%, the ash not more than 6%, the ash insoluble in hydrochloric acid not more than 0.5%, and the crude fibre (which should be determined as in pepper) not more than 25%.

**Adulteration.**—The fruits of other species of pimenta are employed as spices in some countries, but as practically all that used in Great Britain and the United States is obtained from Jamaica there is little substitution. Very little of the fruit is sold retail in the ground state, so that it is rarely, if ever, adulterated in this country, but the usual adulterants may be looked for.

T. McL.  
PINACOL-PINACOLINE TRANS-  
FORMATION (v. Vol. VIII, 1786).

PINASTRIC ACID (v. Vol. VII, 288d).

PINCHBECK, *Gilding metal*. A small group of alloys of copper and zinc which contain from 5 to 20% of zinc. The name Pinchbeck recalls the London clockmaker (died 1732) who introduced the alloy, without publishing the composition, for making cheap jewellery. The alloys resemble gold in colour, work well with tools, and can be rolled out into thin sheets and stamped into watch cases. Old names for the alloys were Dutch metal, Mannheim gold (v. Vol. VI, 122a), Prince's metal, but they are now known as gilding metal. The golden colour of the composition with 5% of zinc is improved by treatment with nitric acid. This alloy is used for decorative fittings in buildings. In America, four of the alloys have the following special names: containing zinc 10%, commercial bronze; 15%, red brass; 17%, rich low brass; 20%, low brass. For further information, see H. Carpenter and J. M. Robertson, "Metals," London, 1939, II, 1303; American Society for Metals, Cleveland, Ohio, 1939.

J. N. G.

**PINEAPPLE.** The fruit of *Ananassativus* Schult., also classified as *Bromelia ananas* L., grown generally in sub-tropical areas of America and in Africa. The fleshy parts of the cored fruit is eaten raw and large quantities are canned for transport. Approximately two-thirds of the whole fruit (after removal of leafy crown) is edible and of this 90% of the weight consists of juice. The waste products of the canning industry serve as a stock feed.

The fruit has the following range of percentage composition:

	Solids.	Protein.	Acids (as citric).	Reducing sugars.
Fresh . . . . .	12.5-16.1	0.42-0.50	0.8-1.5	1.2-0.7
Canned . . . . .	17	0.43	0.35	9.7
	Sucrose.	Fibre.	Ash.	
Fresh . . . . .	-1.7-10.5	0.17-0.32	0.4-0.7	
Canned . . . . .	6.2		0.4	

Kayser (Z. öffentl. Chem. 1909, 15, 187) gives the following data for freshly pressed juice: solids 16-72, citric acid 0-63, invert sugar 4-0, sucrose 8-6 g. per 100 c.c.

The fruit contains approximately 1% of mannitol. The principal acid present is citric and according to Nelson (J. Amer. Chem. Sec. 1925, 47, 1177) this is accompanied by about 13% of Z-malic acid. The colour of the fruit is due largely to carotene (1.5-2.5 mg. per kg.) with small amounts of xanthophyll.

Ash analyses (percentage of fresh edible fruit) include: K<sub>2</sub>O 0.24, CaO 0.04, MgO 0.02, P<sub>2</sub>O<sub>5</sub> 0.03, SO<sub>3</sub> 0.002, Cl 0.1. Iron 3.2, copper 0.7, zinc 2.6, and arsenic 0.08 mg. per kg. of fruit are also reported.

Among reported vitamin assays of pineapples the following are noted: vitamin-C 100-200 I.U., thiamin 30-90 /<sup>100</sup>g., and ascorbic acid 19-60 mg. per 100 g. Samples of canned fruit contain 7-18 and of pressed juice 31-76 mg. of ascorbic acid per 100 g.

A. G. Po.

**PINENES.** Occur very widely distributed in nature. Form the main constituent of American and French oils of turpentine.

*α*-Pinene,

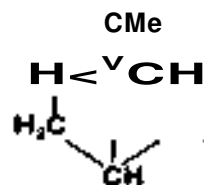

m.p. -50°, b.p. 156°/760 mm.,  $n_D^{20}$  0.8620,  $d_4^{20}$  1.4650,  $[\alpha]_D^{20}$  +51.4°, -51.28°, *dl*-nitrosomorphide, m.p. 103°, *d*- and *l*-, m.p. 81-81.5°.

*P*-Pinene,

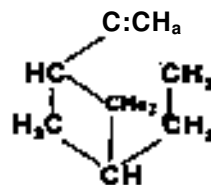

b.p. 164-166°,  $n_D^{20}$  0.8654,  $n_D^{25}$  1.4739,  $[\alpha]_D^{20}$  +28.59°/-22.44°.

J. L. S.

**PINOCAMPHEOL,**

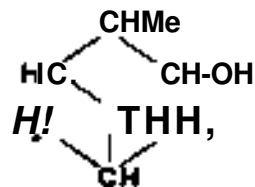

m.p. 56-57°,  $n_D^{20}$  0.9501,  $n_D^{25}$  1.4888,  $[\alpha]_D^{20}$  -46-63°. Occurs in oil of hyssop. Stereoisomeric forms of the alcohol have been described by Schmidt and Schultz (Schimmels Rept. 1934, 97; Ber. 1944, 77 [B], 544).

J. L. S.



## PINOCAMPFONE,

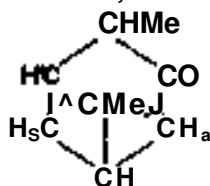

b.p. 212-213°/765 mm.,  $p^{15} < 0.662$ ,  $n_D^{20} 1.4742$ , MD -13-42°; *a-sevnicarbazone*, m.p. 228-229°; *fa* n.p. 182-183°. Occurs in oil of hyssop. Stereoisomeric forms of the ketone have been described by Schmidt and Schulz (Schimmels Kept. 1934, 97; Ber. 1944, 77 [B], 544).

J. t. S.

## PINO&amp;ARVEOL,

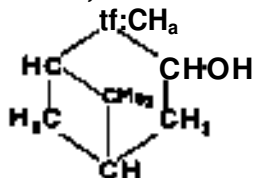

The  $\alpha$ -franc- $\beta$ -volutary alcohol,  $C_{10}H_{16}O$ , occurs in the oil from *Eucalyptus globulosa* grown in Spain, m.p. 5°, b.p. 209-210°/760 mm.,  $p_{20} 0.981$ ,  $n_D^{20} 1.5005$ ,  $a_D -72^\circ$ , hydro- $\alpha$ n *phtholate*, m.p. 116-117°; *phenylurethane*, m.p. 88-90°, *hydrate*, m.p. 190-191°. The  $\omega$ -alcohol has m.p. 51°, b.p. 217-218°/760 mm.,  $p_{20} 1.004$ ,  $T_F^\circ 1.5056$ ,  $[o]_D +55^\circ$  (in alcohol), *p-nitrobenzoate*, m.p. 104° (Schmidt, Ber. 1944, 77 [B], 167).

J. L. S.

## PIIMOCARVONE,

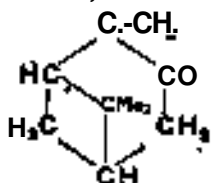

The ketone, *pinocajvone*,  $C_{10}H_{14}O$ , b.p. 94-96°/12 mm.,  $p^{25} 0.9875$ ,  $n_D^{20} 1.4949$ ,  $[a]_D -68.3^\circ$ , *oxime*, m.p. 131°, occurs in the oil from *Eucalyptus globulus* grown in Spain. It is identical with the ketone, *carvopinone*.

J. L. S.

PIOURY, PIURI, PURREE ( $\alpha$ -INDIAN YELLOW Vol. VI, 4246).

## PIPERITOL,

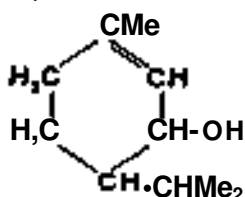

*d-*, b.p. 165-170°/200 mm.,  $p_{11} 0.911$ ,  $n_D^{20} 1.474$ ,  $[a]_D 46.6^\circ$ . Occurs in an oil from an unidentified species of *Andropogon* growing in the United Provinces, India. *Z-*, b.p. 95-06°/10 mm.,  $p^{22} 0.9230$ ,  $n_D^{20} 1.476$ ,  $[a]_D -34.1^\circ$ . Occurs in eucalyptus oils/

J. L. S.

## PIPERITONE,

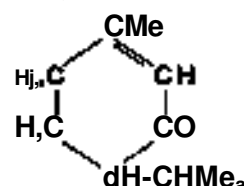

*d-*, b.p. 118-119°/720 mm.,  $p_{10} 0.9344$ ,  $n_D^{20} 1.4848$ ,  $[a]_D 62.5^\circ$ . Occurs in the oil from *Andropogon jwarancusa*. **1-**, m.p. -29°, b.p. 232-5-234-7°,  $p^{20} 0.9330$ ,  $[a]_D -67.8^\circ$ . Occurs in the oil from *Eucalyptus dives*, *a-Semicarbazone*, m.p. 224-226°, *j3-*, m.p. 174-176°, *a-oxime*, m.p. 118-119°, *j8-*, m.p. 88-89°, *a-hydroxylamino-oxime*, m.p. 176°, **3-**, m.p. 185-186°.

J. L. S.

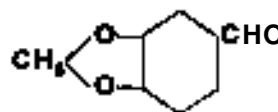
PIPERONAL. *Piperonaidehyde*. *Heliotropin*. 3'-Methylenedioxybenzaldehyde,

Although closely related to natural products such as vanillin and safrole it occurs only in small quantities in the flowers of *Sprsea ulmaria* and according to Elze (Chem.-Ztg. 1910,34,814) in *Robinia pseudacacia*. Its presence in the flowers, *Heliotropium peruvianum*, to which it owes its commercial name has not been proved. Gnadinger (Ind. Eng. Them. 1926,18,588) found a substance giving reactions of piperonal in vanillons and Tahiti beans, but other vanilla beans gave a negative result. Piperonal was formerly prepared by the oxidation of pipefic acid obtained from pipeline (*q.v.*). As an important perfume it is now prepared on a large scale from safrole; full details<sup>9</sup> are given by McLang (Chem. Trade J. 1926,79, \$59). Safrole is first converted, by boiling with alcoholic sodium hydroxide, into *tiosafrole* which is then oxidised in potassium dichromate solution by the gradual addition of sulphuric acid! The product is extracted with benzene, distilled *in vacuo* and crystallised from alcohol with addition of alundum. Suitable plant is described by the author (*ibid.* 1925, 77, 3). Fritzsche (G.P. 207702) claims an improved yield by chromic acid oxidation of *icosafrole* (80 kg.) in presence of sulphanic acid (20 kg.). Davies and Hodgson (J.S.C.I. 1943, 62, 90) confirmed this observation and obtained an 86.5% yield. With potassium permanganate and *tiosafrole* they obtained mainly piperonylic acid,

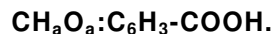

*Properties.*—Piperonal, which has a powerful odour of heliotrope, crystallises from water in large prisms, m.p. 37°; b.p. 263°/760 mm. (*dedbmp.*); 144-145°/14 mm. (Perkin J.C.S. 1916, 109, 907 n.). It is sparingly soluble in cold water, 3-5 g. per litre at 20°, but readily soluble in the common organic solvents. It is liable to become discoloured unless kept in a dark cool place. The ultra-violet absorption

spectrum has been observed by Patterson and Hibbert (Amer. Chem. Abstr. 1944, 38, 250; Grinbaum *et al.*, *ibid.* 1938, 32, 1576); the Raman spectrum by Susz *et al.* (A. 1936, 923; 1935, 1446). Piperonal has no characteristic physiological action (Bianchi, J.C.S. 1915, 108, i, 72). It has a slight growth-promoting activity on vegetation (Grace, Amer. Chem. Abstr. 1938, 32, 4632); the opposite effect is reported by Schmid (Helv. Chim. Acta, 1944, 27, 1197).

**Reactions.**—At one time it was considered that piperonal and piperonylic acid when heated with dilute acid split off carbon and formed respectively protocatechuic aldehyde and protocatechuic acid. It is now known (Parijs, Rec. trav. chim. 1930, 49, 33) that formaldehyde produced by the break-down of the oxymethylene ring condenses with the protocatechuic derivative to form a black resin (*cf.* V. Meyer and P. Jacobsen, "Lehrb. organ. Chem." Vol. II, p. 523, Leipzig, 1902). The  $\text{CH}_2\text{O}_2$  group is split off quantitatively by heating with 28% sulphuric acid; employing this reaction Hunter *et al.* (Amer. Chem. Abstr. 1938, 32, 4533) concluded that a piperonyl group may be contained in the lignin complex. Givaudan & Co. (B.P. 463341) eliminated the methylene group, and obtained protocatechuic aldehyde in 95% yield, by treating piperonal in dichloroethylene with aluminium chloride, and heating the product with toluene. Piperonal shows the reactions of an aromatic aldehyde; it condenses readily with acetone, malonic ester, acetic anhydride, hippuric acid, aromatic amides, and undergoes the Cannizzaro reaction. It forms by conventional methods the ozime (*syn* and *anti* forms), the phenylhydrazone, and the semicarbazone (two forms). These compounds are used in the identification and determination of piperonal.

**Electrolytic Reduction.**—3:4-Methylenedioxybenzyl alcohol was obtained in 90% yield from piperonal in slightly alkaline suspension at c.d. 4 amp./100 cm.<sup>2</sup> (Shima, Amer. Chem. Abstr. 1929, 23; 2371).

**Halogenation.**—6-Bromo- and 6-chloro-piperonal are readily obtained in carbon tetrachloride solution; in acetic acid there are also formed 4:5-dibromocatechol methylene ether and the corresponding dichloro-compound (Robinson *et al.* J.C.S. 1917, 111, 946).

**Nitration.**—The chief product (70% yield) is 6-nitropiperonal, m.p. 98°, with 4-nitro-1:2-methylenedioxybenzene, "m.p. 148° (Salvay, *ibid.* 1909, »5, 1163; Parijs, Rec. trav. chim. 1930, 49, 17). An indigo synthesis was effected by heating an acetone solution of 6-nitropiperonal with dilute sodium hydroxide, which yielded 5:6:5<sup>^</sup>(T-bismethylenedioxyindigo).

**Uses of piperonal** are discussed by H. S. Redgrove (Mfg. Perfumer, 1939, 4, 343).

**Identification and Determination.**—Gnadinger (*I.e.*) and Crocker (Ind. Ei.g. Chem. 1925, 17, 1158) have described colour reactions which are not specific. Rosenthaler's microchemical test (Amer. Chem. Abstr. 1937, 31, 4227) involves formation of the compound with barbituric acid. For some aldehyde reactions, *see* "Reactions" *above*. Radcliffe and Sharpies (J.S.C.I. 1925, 44, 1010B; 11 papers in Perf. & Essent. Oil Reo. in 1924 and 1925) have made a critical

study of methods based on the phenylhydrazone, the p-nitrophenylhydrazone and the semicarbazone (*cf.* Phillips, J.S.C.I. 1923, 42? 948A); the two last-named compounds of piperonal are insoluble in dilute alkali and can thus be separated from the corresponding compounds of vanillin. Aldehydes are first separated as 4-sulphito compounds (Doherty, J.C.S. 1914, 106, ii, 503). The effect of the presence of coumarin was investigated..

J. N. G.

**PITCH.** The term "Pitch" was originally applied to any dark-coloured fusible solid or semi-solid of organic origin whether found as a natural deposit or obtained as a residue from the distillation of a tar or ether carbonaceous substance. The description is no longer applied to naturally occurring *Asphalts* (v. Vol. I, 5166) nor to residues from the distillation of petroleum, previously called "petroleum pitch," but now known as "bitumen" (*ibid.*) or more precisely "asphaltic bitumen."

According to the Glossary of Highway Terms, British Standard 892, which is based on the Technical Dictionary of Road Terms prepared by the Permanent International Association of Road Congresses, pitch is defined as the "black or dark brown solid or semi-solid and cementitious residue remaining after partial evaporation or fractional distillation of tars or tar products." This very restricted use of the word is, however, confined to the Road Industry and more generally the term "pitch" includes the solid or semi-solid residues obtained by distillation of many organic substances other than petroleum products, a prefix indicating the origin of the material, *e.g.*, coal-tar pitch, stearin pitch, rosia pitch, etc.

### COAL-TAR PITCH.

This is the most important type of pitch both as regards the magnitude of its production and the variety of its uses. Approximately two million tons of coal tar containing about one million two hundred thousand tons of pitch were produced in Great Britain in 1947. About one half of this pitch was used in solid form and the remainder, blended with creosote oils, was used as *road tar* and liquid fuel.

### PREPARATION.

Coal-tar pitch is prepared by the distillation of coal tar, being the residue after the removal of the light oils, creosote, and anthracene oil. The tar may be distilled by the batch method in a pot still or by a continuous process in some form of pipe still. The characteristics of the pitch are usually controlled in pot-still distillation by the quantity of distillate taken off, and in continuous distillation by the temperature at the end of the coil. The pitch in the liquid condition is run from the stills through coolers and is then usually allowed to flow over large flat areas known as "pitch beds," where by further cooling it solidifies; it is subsequently broken up by hand or by mechanical means. For certain purposes the liquid pitch may be filled into drums or other containers, or supplied hot in insulated tank wagons.

The proportion of the tar obtained as pitch depends mainly upon the nature of the tar and, to a less extent, on the methods of distillation. During distillation additional pitch may be formed as a result of the polymerisation or cracking of certain of the lower boiling constituents, more particularly those of phenolic character. Accordingly, a continuous still where the tar is exposed to high temperatures for a shorter time, gives a somewhat lower yield of pitch than a pot still, a fact which is an advantage since, in general, pitch is of less value than tar oils. In order to increase the yield of oils in pot-still distillation and thus reduce the proportion of pitch, steam or some other inert gas may be passed through the charge, thus increasing the rate of distillation and reducing the maximum temperature required.

It has been indicated in another article (v. COAL TAB, Vol. III, 207d) that the nature and properties of the tar are dependent on the conditions of carbonisation of the coal. With increase in the temperature of carbonisation the tar tends to become less phenolic and more highly aromatic. These changes are accompanied by corresponding changes in the properties of the pitch as well as by an increase in the pitch content of the tar.

The most usual grade of pitch is that known as *medium-soft pitch* which has a softening point (ring and ball) of about 78°o. Typical yields of medium-soft pitch in pot-still distillation of various types of coal tar are given below; the figures are, however, subject to fairly wide variation.

TABLE I.—PERCENTAGE YIELDS OF MEDIUM-SOFT PITCH FROM CRUDE TARS.

Low temperature tar	35
Vertical gas retort tar	50
Horizontal gas retort tar	60
Coke oven tar	65

For certain purposes coal-tar pitches are required with a softening point lower than that of medium-soft pitch and such material, known as "*soft pitch*," is prepared either by stopping the distillation process at a lower temperature, so that some of the higher boiling oils remain in the residue, or by fluxing medium-soft pitch with the requisite proportion of a suitable tar oil, such as anthracene oil.<sup>3</sup> The softening point of a soft pitch may be as low as 30°o. (ring and ball test) in which case the material flows appreciably at room temperature. There is no sharp line of demarcation between pitch and tar, but materials of softening point lower than 30°o. are usually termed "tars." Pitch is also required at times with a softening point higher than 80°c.; such materials, known as "*hard pitch*," are prepared by continuing the distillation process, usually with the passage of steam or inert gas, or by air-blowing medium soft pitch at temperatures from 300° to 370°o. The softening point of hard pitch may be as high as 250°c. Such materials are sometimes produced in a granulated form by spraying the molten pitch into water or by other similar methods:

#### PHYSICAL PROPERTIES.

The harder grades of coal-tar pitch are brittle and break with a conchoidal fracture. They are black or dark brown in colour, the intensity of colour being dependent upon the carbonising conditions under which the tar was produced. Low temperature pitch gives a brown streak on porcelain and can be fairly successfully pigmented. High temperature pitches, which are much darker in colour, offer considerably less scope for pigmentation.

Coal-tar pitches are largely soluble in benzene, toluene, or carbon disulphide and the solutions have a characteristic green fluorescence. The insoluble residue is commonly known as *free carbon* although this is not a true description since it contains about 3% each of hydrogen and oxygen.<sup>3</sup> The proportion insoluble in toluene depends on the source and method of preparation of the pitch and on its softening point. The medium-soft grades of low temperature, vertical, and horizontal pitches usually contain respectively from 1 to 7%, 5 to 19%, and 15 to 30% of insoluble matter. The solubility is somewhat greater in polar solvents such as pyridine and nitro-benzene.<sup>4</sup> When, as is normally the case, coal-tar pitches are free from the lower boiling phenols and tar bases, they are practically insoluble in and unaffected by water, dilute acids, or alkalis, or by salt solutions.

There are no fundamental differences in properties between pitch and tar and there can be no sharp division between the two materials. The dividing line is purely arbitrary and is dictated by convenience for commercial reasons, rather than on scientific grounds. Actually, pitches are very highly viscous liquids and the viscosity at ordinary room temperatures can be measured by means of suitable instruments, e.g., at 30°c, medium-soft pitch has a viscosity of about 10<sup>10</sup> poises.<sup>5, 6</sup> When subjected to a deforming force pitch behaves as a Newtonian fluid,<sup>7</sup> the rate of shear being directly proportional to the applied force; in this respect coal-tar pitch differs from many asphaltic bitumens, which often exhibit anomalous behaviour. The viscosity of pitch varies considerably with temperature, and the following relationship holds over a limited range (i.e., about 100 Fahrenheit degrees):

$$\eta = \eta_0 e^{-n\theta/a}$$

where  $\theta$  is the temperature in °F.,  $\eta$  is the viscosity, and  $n$  and  $a$  are constants.

The term  $n$  has been called the *logarithmic temperature coefficient*, and corresponds to the slope of the straight line obtained by plotting the logarithm of the viscosity against the logarithm of the temperature. The magnitude of  $n$  varies according to the softening point of the pitch, ranging from about 11 for a softening point of 35°c. (R. and B.) to about 18 for a softening point of 78°o. (R. and B.).<sup>8, 9</sup> The type of coal tar from which the pitch is obtained has little effect, but the value of  $n$  for any particular softening point can be reduced by incorporating fine mineral fillers in the pitch, or by dispersing coal of a suitable type at an elevated temperature.<sup>10</sup> In either case the temperature coefficient of the resultant material

is that of the softer pitch used as the basic material.

The *density* of coal-tar pitch varies with the softening point and with the type of tar from which the pitch is obtained. At 15°C. the density of medium-soft pitch (B. and B., 78°C.) ranges from 1.11 to 1.33 g. per c.c. and that of soft pitch (R. and B., 35°C.) from 1.08 to 1.28 g. per c.c. A relationship has been noted<sup>5</sup> between the density of tar products and the temperature of carbonisation of the coal; the lower this temperature the lower is the density of the tar products. On the basis of density, tars and the pitches therefrom can be classified as low temperature, low medium temperature (vertical gas retort), high medium temperature (horizontal gas retort), and high temperature (horizontal gas retort and coke ovens). For medium-soft pitch from these various sources the density ranges are:

Low temperature . . .	1.12-1.18 g. per c.c.
Low medium . . .	1.18-1.24 " "
High medium . . .	1.24-1.29 " "
High temperature . . .	1.29-1.34 " "

Pitch is a good electrical insulator under low voltage conditions, the *resistivity* being of the order of  $6 \times 10^{10}$  ohm-cm, at room temperatures<sup>16</sup>; its *dielectric constant* decreases with increase in temperature, and at 25°C. lies between 2.25 and 3.55.<sup>11</sup>

The *thermal conductivity* of pitch is about 0.00033 C.G.S. units, equivalent to 0.08 B.Th.U. per hour per sq. ft. per ft. °F.<sup>12</sup> Its *specific heat* ranges from 0.34 to 0.45.<sup>18</sup> These values refer to a temperature range of 15-200°C. Pitch has no *latent heat of fusion*. The cubical coefficient of *thermal expansion* over a temperature range of 0-200°C. is 0.00046-0.00056 per °C.<sup>19</sup> which corresponds to a reduction in density of 0.0006 g. per c.c. per °C. temperature rise. The *calorific value*, depends to some extent on the softening point, but usually lies between 15,800 and 16,300 B.Th.U. per lb.<sup>18</sup>

#### METHODS OF TEST.

Pitches are usually graded according to their *softening point*, i.e., the temperature at which a certain degree of softness is attained. There are several methods for making such determinations. Since pitch is a liquid even at room temperature, it does not change at any definite temperature from the solid or semi-solid state to a liquid state, but becomes progressively softer and less viscous as the temperature rises. Softening-point tests give the temperature at which the viscosity is reduced to a certain value when the temperature is raised under closely defined conditions. In Great Britain the *ring and ball* and the *Kraemer and Sarnow* -tests<sup>20</sup> are the ones most generally used, and in America the *half-inch cube test*<sup>21</sup> and the *twisting point*<sup>TM</sup>. Certain viscosity tests applied to tars used for road purposes can also be applied to pitch, for example, a pitch can be defined in terms of *equiviscous temperature* (E.V.T.)<sup>20</sup> which is the temperature in °C. at which a tar or pitch has a viscosity on the standard tar viscometer of 50 seconds

(equivalent to a kinematic viscosity of about 200 stokes). These tests are all simply related<sup>8</sup>:

Softening Point (R. and B.),

=Half-inch Cube Test approx.

^Softening Point (K. and S.)+8°C.

=Twisting Point+30°C.

=E.V.T. -18-5°C.

The various standard tests used in Great Britain, including those for the determination of *water*, *free carbon*, *volatile matter*, *ash*, etc., are described in "Standard Methods for Testing Tar and Its Products."<sup>20</sup>

Chemical Tests are sometimes used to differentiate coal-tar pitches from other pitches and from asphaltic bitumen. Thus the coal-tar pitches contain little or no saponifiable matter, but do contain anthracene and phenolic bodies; the detection or determination of such compounds forms the basis of certain chemical tests which may be applied. The *anthraquinone reaction*<sup>22</sup> is useful in indicating the presence of anthracene, which is a characteristic component of the softer coal-tar pitches. The material is distilled and the oil distilling between 270° and 355°C, which would contain the anthracene, is separated. The solid portion separating from this oil is recrystallised from alcohol and refluxed with glacial acetic acid. Oxidation is then effected by treatment with chromic acid solution, and anthraquinone is precipitated on dilution with water. When 1 part of anthraquinone is boiled with 2 parts of zinc dust, and 30 parts of 50% sodium hydroxide solution, an intense red colour develops which fades on filtering in contact with air.

Another test distinguishing pitches from bitumen<sup>23</sup> depends upon the detection of *phenolic compounds*, which are characteristic of most pitches. The substance is boiled with N. sodium hydroxide solution and filtered. Treatment of the cold solution with ^-diazobenzene sulphonic acid (diazotised sulphanilic acid) gives, if phenols are present, a red precipitate or a red coloration, which may be fugitive. On *sulphonation*,<sup>24</sup> coal-tar pitches and the wood pitches give no insoluble residues; other pitches give various proportions of insoluble substances, while bitumens, which are almost completely insoluble, give a bulky precipitate.

Coal-tar pitches and bitumens give very low *saponification and acid values*,<sup>25</sup> whereas the fat pitches and wood pitches give high values. The presence of rosin, a characteristic of wood pitches, can be detected by the *Liebermann-Storch reaction*<sup>26</sup> in which the substance is heated with acetic anhydride and the product treated with dilute sulphuric acid. If rosin is present a fugitive violet coloration is formed.

#### COMPOSITION AND CONSTITUTION.

The Chemical Composition of coal-tar pitch is dependent on the temperature of carbonisation of the parent coal, and to a smaller extent on the softening point of the pitch; the nature of the coal carbonised has little effect. With increase in temperature of carbonisation the percentages of hydrogen and of oxygen both decrease. The

hydrogen content also decreases slightly with increase in softening point. Typical analyses of medium-soft pitches are given below<sup>13</sup>:

TABLE II?—ULTIMATE PERCENTAGE ANALYSES OF PITCHES.

Type.	Ash.	C.	H.	S.	N <sub>2</sub>	O by diff.
JrfHi Aromatic :						
Sample A :	0.18	87.48	6.02	0.68	1.50	4.14
» B :	0.06	89.53	5.61	0.43	1.38	2.99
High Aromatic :						
Sample 0 :	0.13	90.42	5.23	0.65	1.38	2.19
» 9 :	0.28	90.34	5.03	0.84	1.47	2.09

The chemical constitution of pitch is very complex. The main constituents are highly polymerised resinous compounds of an aromatic nature, together with many high boiling aromatic hydrocarbons and their derivatives, and some unsaturated and paraffinoid bodies.<sup>28</sup> The proportion of unsaturateds and paraffins is very low in high temperature pitch but increases as the temperature of carbonisation is reduced. For this reason pitches from coke oven and horizontal retort tars are sometimes known as *high aromatic pitches*, and those from vertical retort tar as *low aromatic pitches*. Bases such as acridine and its higher homologues and also phenolic substances are present, the proportion of the latter being higher in the low aromatic pitches. Certain of the constituents of pitch have carcinogenic properties (v. CARCINOGENIC HYDROCARBONS, Vol. II, 378a).

The Physical Constitution of pitch has been investigated by solvent analysis. The matter insoluble in toluene may be resolved into a portion insoluble in pyridine, and a resinous material soluble in pyridine. The latter is normally in solution in the pitch but is precipitated therefrom by benzene or toluene. These two fractions have been called C<sub>1</sub> and C<sub>2</sub> respectively.<sup>29</sup> The C<sub>2</sub> in pitch is visible when a very thin film is viewed under the microscope. Those components of the pitch soluble in benzene but insoluble in light petroleum have been called "tar resins." Low-temperature tar has been separated by solvent methods without distillation<sup>30</sup> giving soluble portions of high boiling-point which would normally be present in the pitch. The amorphous solids extracted by alkali have been termed *resinols* and those soluble in dilute acid *resinamines*. It is characteristic of low temperature pitch that it contains a high proportion of resinols. Similar bodies are present to a smaller extent in vertical retort, or low aromatic pitch but are almost absent from high aromatic pitch.

In a study of the constitution of road tar,<sup>31</sup> pitch of softening point about 100°o. (R. and B.), obtained by vacuum distillation to 250°c, was further separated by solvents into different types of resins. From the various observations made in this work, including the cryoscopic behaviour in benzene of the fractions of higher molecular weight, the viscosity of the dispersions in oil, and the particulate structure

revealed by the electron microscope, it was concluded that tar (and thus pitch) is an associated colloid in which the micelles are composed of a core of hydrocarbon derivatives of high molecular weight, surrounded by a solvation layer of smaller molecules. These micelles are dispersed in a continuous oily medium and there is no abrupt discontinuity of phase between this medium and the nuclei of the micelles!

#### USES OF COAL-TAR PITCH.

**Briquetting.**—The main use of coal-tar pitch is for the briquetting of fine coal, lignite, coke breeze, etc., for which purpose the medium-soft grade [softening point about 78°o. (R. and B.)] is used. The volatile-matter test and the "free carbon" content are generally used to determine the suitability of pitch for this process. It has been suggested<sup>32</sup> that the "free carbon" content should not exceed 30%, since this material is to some extent a diluent, and that, in the volatile-matter test, the pitch should yield a button of coke, not too voluminous but flat and of a very dark greyish colour. The usual method of employing pitch for briquetting is to crush the pitch to pass  $\frac{1}{8}$  in. and feed it with the coal or other material to be briquetted, into a continuous mixer which is heated internally by steam. The proportion of pitch required for coal is normally between 5 and 8% but higher proportions may be required for fine slacks and coke breeze. The hot mixture is conveyed by a screw feed to a press or to indented rollers where it is formed into conveniently shaped blocks or ovoids which harden on cooling. Steel turnings, flue dusts, and ores are also briquetted with pitch, in order to simplify transport, processing, etc.<sup>33</sup>

Pitch is used as the binder for carbon, graphite, or pitch coke in the manufacture of electrodes (v. Vol. II, 313(2)). A hot mixture prepared and extruded or moulded in the form of rods; the pitch binder is then converted to pitch-coke by carbonisation. When large electrodes, such as those used in the production of aluminium, are required, coke and anthracite are mixed with pitch and tar in suitable proportions and the mixture is extruded into the reduction furnace so that the pitch is carbonised and the electrode is formed *in situ*.

**Pitch Coke.**—Carbonisation of coal-tar pitch produces *pitch coke*. This product has a number of commercial applications on account of its high degree of purity and freedom from deleterious mineral constituents. Owing to the fluidity of hot pitch, its carbonisation presents special problems. In some processes cast-iron pot stills are used and in others specially designed coke ovens, of the beehive or chamber type.<sup>34</sup> The ovens are either filled with molten pitch (usually hard pitch of R. and B. 160°o.) by pipe line through the top of the oven, or charged with granulated hard pitch; the doors are luted with clay. In the cast-iron stills the end temperature does not exceed 700°o., but in the ovens temperatures of 1,100-1,200°o. may be reached.

The carbon content of pitch coke may range from 90 to 98% and the ash from 0.2 to 0.8%. Pitch cokes with a low volatile matter content

are used mainly in the manufacture of electrodes and in the production of high-grade castings in the metallurgical industries. High volatile pitch cokes have been suggested as household fuels and for producer-gas traction.

The yield of pitch coke may range from 50 to 70% depending on the method of carbonisation and the type of pitch used. The distillate (*pitch-cokirig oil*) comprises 20 to 40% of the pitch and is a viscous grease-like product; it is used as a fuel, or as a plasticiser in the preparation of special types of road tar. From 5 to 15% of the pitch is evolved as a combustible gas (mainly hydrogen) which is used to heat the ovens.

**Pitch as a Fuel.**—Another important use of coal-tar pitch is as a fuel; it is generally used in one of three forms:

- (a) Mixed with creosote (a creosote/pitch fuel was used in Britain in large quantities during the First and Second World Wars to replace imported petroleum fuel oil).
- (b) In liquid form without added creosote (medium-soft pitch).
- (c) Pulverised and fired in a similar manner to pulverised coal (hard pitch having a softening point greater than 100°C).

These fuels, together with the methods of use are described in "Coal-Tar Fuels."

(a) *Creosote/Pitch Mixture.*—In general, mixtures of pitch and creosote are handled in a similar manner to heavy petroleum fuel oil, although certain special methods are used mainly with the object of avoiding troubles due to sedimentation of insoluble matter. Various types of burner are used, atomisation being effected by steam or by compressed air.

(b) *Molten Pitch.*—Medium-soft pitch used as a liquid fuel is normally supplied and stored in the solid condition and is melted and heated to 360-400°F. before use. Various types of melters are used based on one of the following principles:

- (i) The hot molten pitch is circulated through and over the solid material,
- (ii) The pitch is melted by contact with a heated surface and the liquified material drains away as it is formed.

These methods are both designed to offset the low thermal conductivity of pitch and to avoid decomposition by overheating.

(c) *Pulverised Pitch.*—Hard pitch, with a softening point over 100°C. E. and B. can be used as a pulverised fuel, for which purpose it is superior to other pulverised fuels because of its low ash content. For the pulverisation of the pitch a high-speed, air-swept impact machine is used. The pulverised pitch may be fed directly to the furnace, or for small furnaces it may be stored and supplied through a portable fan and feeder.

**Pitch in Building Materials.**—Coal-tar pitch is used in the manufacture of *roofing felt* and similar waterproof, impregnated fabrics. In the usual method of roofing-felt manufacture the felt is impregnated with molten pitch of softening point 35-45°C. (R. and B.).<sup>86</sup> A slight excess of pitch is left on the surface of the felt

and this is covered while still hot with sand or other fine aggregate. In another method the felt is squeezed dry after impregnation and an external coating of a mixture, of pitch and fine mineral filler is applied. A soft pitch of about 50°C. (B. and B.) is used as a sealing and dressing compound in the construction of laminated roofs.

Pitch is also employed as the binder in mastics used for flooring and for roofing. For *flooring mastic* a pitch of softening point 60-70°C. (R. and B.) is used,<sup>36</sup> and is mixed to the extent of some 20% with fine mineral matter (largely below 200 mesh) and a small proportion of coarser grit. Wood fillers are sometimes included. The hot, semi-fluid mixture is laid to the required thickness by hand floating.<sup>1</sup>

For decorative purposes pitch mastic can be coloured by the addition of a suitable pigment. In this case it is necessary to use a pitch, such as that from low-temperature tar, which contains little or no free carbon. Certain types of vertical retort pitch can also be used and processes have been described<sup>37</sup> for rendering high temperature pitch more suitable for pigmentation by removing insoluble matter by solvent extraction:

*Pitch roofing mastic*, for the construction of flat roofs, is prepared and used in the same way as flooring mastic, but a binder of lower softening point [40°C. (R. and B.)] is employed.

**Other Uses of Coal-Tar Pitch.**—*Paints* having a coal-tar pitch base give excellent protection to metals against corrosion owing to their very high resistance to water penetration.<sup>88</sup> Such paints are sometimes known as "*black varnish*" and usually consist of a soft coal-tar pitch thinned with coal-tar naphtha.<sup>39</sup> The coal-tar pitch may be partly or completely substituted by *water-gas pitch* (*v. infra*) in order to give the paint a higher gloss. Vegetable oils or fatty-acid pitches are sometimes incorporated as plasticisers, and fine mineral or organic fillers, and pigments may be added to give easier brushing and greater stability to the paint film.<sup>40</sup> Molten coal-tar pitch is applied as a *corrosion preventive* to steel and cast-iron pipes by dipping, and is also used for the impregnation of *pipe wrappings*.

As an *electrical insulator*, a soft pitch of about 50°C. (R. and B.) is used for the sealing of dry batteries. Soft pitch is sometimes blended with Lake asphalt for use in the impregnation of the wrappings or "servings" of electric cables.

Coal-tar pitch has also found some use in the form of *emulsions*. In the case of the higher softening-point pitches a bentonite-clay slurry is usually employed as the emulsifying agent. Pitch emulsions are used for the production of waterproof millboard and wrapping papers, adhesives, and certain special paints. Cheap *thermo-plastics* are produced from mixtures of pitch and asbestos fibre. A product known as *plastic armour*<sup>41</sup> was extensively used in the Second World War as a substitute for armour plate. It consisted essentially of a mixture of pitch and graded stone, filled into suitable metal containers. Powdered pitch has been used as an extinguisher<sup>48</sup> for magnesium and similar metal fires.

## THE LESS\* COMMON PITCHES.

Pitches are obtained from the distillation of tars other than coal tar, and are formed during the distillation of a variety of natural oils and fats. The properties of these pitches vary considerably, being dependent upon the maximum temperature of the distillation and on the period of heating.\*<sup>4</sup> No definite figures can therefore be given for their physical and chemical properties; most of them may have a consistency ranging from that of a viscous fluid to that of a hard brittle solid. The simplest\* and in some cases the most reliable, indication of the source of a pitch is afforded by the odour of the fumes emitted on heating. The pitches, other than coal-tar pitch, which are used commercially include the following:

**Anthracene Pitch.**—This is the residue obtained in the purification of anthracene by distillation. It is hard, black, and glossy with high temperature susceptibility.

**Blast-furnace Pitch and Producer Pitch** are residues from the distillation of blast-furnace and producer tars. They are essentially coal-tar pitches and have similar properties but normally contain a higher proportion (10-20%) of mineral matter; their densities range from 1.2 to 1.3. They have high temperature-susceptibility and moderate to good weathering properties. They are normally used as fuel but may be used for briquetting and for cheap paints.

**Brewer's (or Rosin) Pitch,** *v. infra*, "Wood Pitches."

**Burgundy Pitch** is an *oleo-resin* from Norway Spruce.

**Canada Pitch** is an *oleo-resin* from the Hemlock Spruce (*v. Vol. II, 2616*).

**Cresol Pitch (Tar-Acid Pitch)** is the residue from the distillation of crude cresols. It is soluble in caustic alkali and in alcohol and is used to some extent in the preparation of lacquers.

## THE FATTY ACID PITCHES.

(a) **Bone-tar Pitch or Bone-oil Pitch** is the residue from the distillation of *bone oil* or *dippel oil* obtained as a by-product in the manufacture of ivory black or bone charcoal. It should not be confused with *bone-fat pitch* (*v. infra*). It is the blackest of all pitches and has a brilliant lustre. When strongly heated it evolves fumes which contain basic substances and have the typical nauseating smell of bone oil. It is almost completely soluble in carbon disulphide and in pyridine bases but less so in light petroleum. Its solutions are dark brown and exhibit no fluorescence. Normally it is fairly hard, contains a high proportion of unsaponifiable matter and is in consequence moderately susceptible to temperature changes and not so weather resistant as the fatty-acid pitches. The density lies between 1.00 and 1.20. It is produced only in small quantities but is highly prized for the manufacture of japans and varnishes.

(6) **Fatty-acid Pitches (Stearin Pitches)** are the residues from the steam distillation of candle-stock and soap-stock fatty acids and the fatty acids from cotton-seed foots, waste fats, and grease's, etc. These pitches generally have

a high solubility in carbon disulphide and in light petroleum, giving non-fluorescent solutions. Their temperature susceptibility and weathering properties are in general related to the content of saponifiable matter. This is usually high in the softer grades which are consequently highly weatherproof and have low temperature-susceptibility. The weather resistance of some asphaltic bitumens is said to be increased by the incorporation of such fatty acid pitches. The density ranges from 0.95 to 1.1 and the coefficient of cubical expansion approximates to 0.0009 per °C. Individual characteristics are:

**Bone-Fat Pitch:** The distillation residue of the fatty acids from the fat extracted from bones by solvents or by steaming (*v. BONE FAT, Vol. II, 286*). Black in colour and usually soft, it contains an exceptionally high proportion of unsaponifiable matter and is therefore not very weather resistant.

**Lard Pitch:** Brown and usually very soft, this pitch contains very little unsaponifiable matter.

**Tallow Pitch:** Brown, usually hard, with only a moderately low content of unsaponifiable matter; good weather resistance.

**Palm-Oil Pitch:** Brown to black, the soft grades being dull. The hard grades contain a considerable proportion of unsaponifiable matter and have only moderate weather resistance.

**Cottonseed-foots Pitch:** Brown to black, usually soft and of good weather resistance.

**Corn-oil-foots Pitch:** Black, not very soft, but extremely rubbery with a low temperature-susceptibility.

**Packing-house Pitch:** Brown to black, usually soft with a rather high temperature-susceptibility; low content of unsaponifiable matter.

**Garbage and Sewage Pitch:** Black, normally soft, but may have a high content of unsaponifiable matter, low weather-resistance, and rather high temperature-susceptibility.

**Whale-Oil Pitch:** Bright and black, it contains a fairly high proportion of unsaponifiable matter.

**Woolgrease Pitch:** Black, usually soft, but with a high temperature-susceptibility and high content of unsaponifiable matter. Also known as *cholesterol pitch* owing to the presence of cholesterol, which gives the *Liebermann-Storch* reaction for rosins.<sup>26</sup> It contains an insoluble hydroxy-fatty acid (m.p. 80-82°).«

**Wool-Oil Pitch:** Obtained from the oil used to lubricate the wool fibres during processing. It contains no cholesterol and its properties to some extent depend on the oil used.

**Uses.**—The chief use of the fatty-acid pitches is in the preparation of *varnishes*, lacquers, and japans, for which purpose they may be used by themselves or in admixture with drying and semi-drying oils, bitumen, coal tar, and coal-tar pitch, etc. The harder grades are usually reserved for baking japans because of their inferior weather resistance when unboiled. The soft grades find some use as *lubricant*\* under the name of *neck-grease*, wool-grease pitch being particularly useful for this purpose. *Other uses*



include insulating materials and lacquers for cables and armatures, printing, gravure, and copying inks, coloured tiles, and boot polishes.

Glycerine Pitch is the residue from the steam distillation of glycerol. It is greenish-brown to black in colour and consists very largely of polyglycerins, so that it is appreciably soluble in water. It is used for hectograph jellies, printing inks, and boot polishes.

Lignite Pitch and Peat Pitch.—Lignite pitch is sometimes obtained as the residue from the distillation of lignite tar although the distillation is usually carried to the coking stage. Peat pitch is obtained from the tar formed in the destructive distillation of peat or in producers operating on peat. These two pitches are very similar in properties. They are black, usually hard, and contain little or no saponifiable matter, no anthracene or rosin, and considerable "free carbon." They are used for briquetting lignite and peat and for the production of cheap paints.

Montan-wax Pitch (Montan Pitch) is formed in the distillation of Montan Wax (*v. Vol. VIII*, p. 2356); it is a dark waxy pitch almost free from acidic substances. It is extensively used, together with montan wax, for boot polishes, gramophone records, etc.

Naphthol Pitch and Naphthylamine Pitch are obtained in the refining of  $\beta$ -naphthol and  $\beta$ -naphthylamine and find some use in the manufacture of lacquers.

Oil-gas Pitch, *v. infra* •• *Water-Gas Pitch.*"  
Peat Pitch, *v. supra* "*Lignite Pitch.*"  
Palm Pitch, Packing House Pitch, *v. supra* "*Fat Pitches.*"  
Producer-gas Pitch *v. supra* "*Blast-urnace Pitch.*"

Rosin Pitch, *v. infra* "*Wood Pitches*"  
Shale-tar Pitch.—Shale tar is normally distilled to the coking stage but a small quantity of shale pitch is obtained from the mixed acids and alkaline washes obtained in the refining of the distillates. It is very similar to *Lignite Pitch (q.v.)*.

Stearin Pitch, *v. supra* "*Fat Pitches.*"  
Tall-oil Pitch or Tall Pitch, *v. infra* "*Wood Pitches.*"

Water-gas and Oil-gas Pitches.—These are the residues from the distillation of the tars obtained during the carburetting of water gas and the manufacture of oil gas. They are black with a bright lustre, and are almost completely soluble in pyridine bases, they are less soluble in carbon disulphide and benzene. The "free carbon" content is less than that of coal-tar pitch and the solutions show no fluorescence. They have a high temperature-susceptibility but are very resistant to water and have good weathering properties. Their *density* ranges from 1.10 to 1.35, oil-gas pitch being usually denser than water-gas pitch. On account of their brilliant lustre they are highly valued for the production of paints and black varnishes.

#### WOOD PITCHES.

(a)\* *Wood-tar Pitches.*—Two types of wood-tar pitch are generally recognised; they are the residues from the distillation of the two types of wood tar: *Hard-wood tar* derived from woods containing little resin, *e.g.*, oak, beech,

poplar, etc., and *soft-wood*, or *Stockholm tar*, derived from woods containing a high proportion of resin, *e.g.*, fir, pine, etc. *Soft-wood pitch* is only rarely manufactured since the tar is mainly used without distillation.

*Properties.*—These two types of pitch differ less than the corresponding tars.<sup>27</sup> *Soft-wood pitches* tend to have a lower specific gravity and are paler in colour; they are soluble to a slightly greater extent and contain more resin acids. All wood pitches "contain these acids and consequently give a positive Liebermann-Storch reaction. *Wood-tar pitches* have a *density* between 1.10 and 1.30, and are black or dark brown in colour with a particularly bright lustre. They are moderately soluble in carbon disulphide and in benzene, giving solutions free from fluorescence. Alcohol and aqueous alkalis also dissolve them to an appreciable extent. When the alkaline solution is boiled an evil-smelling oil is liberated. These pitches have an extremely high temperature susceptibility and are notoriously non-weather-resistant, being oxidised to powder on exposure. They are in consequence of little use as paints in spite of their attractive appearance. They are used mainly for the preparation of plastics and insulating materials by condensation and polymerisation with formaldehyde. They are also used for briquetting charcoal but the briquettes need to be carbonised because of the offensive odour given off by the pitch on ignition.

(6) *Rosin Pitch (Brewer's Pitch)* is the residue obtained when rosin (colophony) is distilled in the manufacture of rosin spirit and oils. It is dull black in colour and is normally hard and exceptionally brittle. It contains a considerable proportion of rosin acids but no fatty acids, sulphur, or paraffins. It has a high temperature susceptibility and very poor weathering properties. The *density* ranges from 1.05 to 1.15. It is used for lining barrels and casks and for increasing the hardness of other pitches.

(c) *Tall Pitch or Tall-oil Pitch.*—This pitch is the residue from the distillation of "*Tall Oil*" (*v. Vol. I*, 655r), a by-product of the sulphite-sulphate treatment of wood pulp. It is amber coloured and in distinction from the wood-tar pitches, consist mainly of fatty acids with only a small proportion of resin acids. It has been used as a war-time substitute for part of the Unseed oil in oil paints.<sup>47</sup>

Wool-grease Pitch, *v. supra* "*Fat Pitches.*"

#### References.

- 1 H. M. Spiers, "Technical Data on Fuel," Brit. Nat. Committee, World Power Conference, 4th ed., 1943, 267.
- 2 T. H. Blakeley and J. G. Mitchell, J.S.C.I., 1943, 62, 179.
- 3 J. M. Weiss, J. Ind. Eng. Chem. 1914, 6, 279.
- \* B. J. Fischer, Asphalt u. Teer, 1930, 30, 1332.
- 5 Road Tar Bulletin No. 2, B.B.T.A., London, 1945.
- 6 W. F. Fair and B. W. Volkman, Ind. Eng. Chem. [Anal.], 1943, 15, 240.
- 7 E. V. Evans and H. Pickard, Fuel, 1931, 10, 352; "Nature and Properties of Coal Tar," South Met. Gas Co., London, 1931.
- 8 A. L. Deadman and G. H. Fidge, J.S.C.I. 1937, 56, 427T.
- 9 "Preparation of Thin Tar Carpets," South Met. Gas Co., London, 1937; see also (\*).
- 10 B.P. 559003, 1942; U.S.P. 2319326, 1943; G.P. 693269, 1938.

- " Coal Tar Fuels," Assoc. Tar Distillers, London, 1944, pp. 17 et seq.  
 12 W.J., p. 26.  
 13 *Ibid.*, p. 23.  
 14 T. H. Blakeley, - J.S.C.I. 1938, 57, 7; 1940, 59, 87.  
 15 G. H. Ittridge, Gas World, 1944, 121, Cok. Sect. 87.  
 16 H. Walther, Kolloid-Z., 1942, 99, 98.  
 17 " Report of the Fuel Research Board," D.S.I.R., London, 1928.  
 18 J. M. Weiss, J. Franklin Inst. 1911, 172, 277.  
 19 " Standard Methods of Testing Tar and its Products," Standardization of Tar Products Terts Committee, London, 1938, 2nd ed., pp. 306 et seq.  
 20 A.S.T.M. Standards 1944," A.S.T.M., Philadelphia, Pa. 1944, H, p. 581 (D61-38).  
 21 H. Abraham, "Asphalts and Allied Substances," D. Van Nostrand Co., New York, 1945, 5th ed. p. 1236.  
 22 *Op. cit.*, p. 1235.  
 23 *Op. cit.*, p. 1213.  
 24 *Op. cit.*, p. 1217; see also J. Lewkowitsch, " Chemistry; Technology and Analysis of Oils, Fats, and Waxes," Ourajlian, London, 1913, 5th ed., I, p. 379.  
 25 H. Abraham, *op. cit.*, p. 1237; also J. Lewkowitsch, *op. cit.*, I, 610, 624.  
 26 H. Abraham, *op. cit.*, p. 329.  
 27 p. E. Spielman, "Constituents of Coal Tar," Longmans, London, 1924; A. E. Everett, "Higher Coal Tar Hydrocarbons," Longmans, London, 1927; J. W. Cook et al., J.C.S.S. 1933, etc.; O. Kruber, Berl. 1941, 74 [B], 1688; W.3, 76 [B], 128, etc.; G. T. Morgan et al., J.S.C.I. 1935, 54, 197, etc.; F. Trefny, Oel u. Kohle, 1942, 38, 766.  
 28 W. G. Adam, et al., J.S.C.I. 1937, 56, 414T.  
 29 G. T. Morgan et al., *ibid.* 1929, 48, 29T.  
 30 E. J. Dickinson, *ibid.* 1945, 64, 121.  
 31 A. R. Warnes, "Coal Tar Distillation," Ernest Benn, Ltd., London, 1923, p. 335.  
 32 A. L. Sfilman, "Briquetting," Chem. Pub. Co., Easton, Pa. 1923.  
 33 F. Rosendahl, Teer u. Bitumen, 1932, 30, 360; A. Fisher, Gas J. 1935, 210, 208; A. Thau, Teer u. Bitumen, 1942, 40, 25; G.P. 704816 (1937); 705576 (1939); 720642 (1940).  
 34 "Bituminous Roofing Felt, B.S. 989," Brit. Standards Inst., London, 1941.  
 35 "Pitch Mastic Flooring, B.S. 1450-1948," and "B.S. 1375-1947," Brit. Standards Inst., London.  
 36 B.P. 538308, 1940.  
 37 H. Walther, Asphalt Teer Strajsenbautech, 1936, 36, 1001.  
 38 "Black Paint (Tar Base), B.S. 1070," Brit. Standards Inst., London, 1942.  
 39 B.P. 560390, 1942.  
 40 J. P. Lawrie, Chem. and Ind., 1945, 64, 261.  
 41 S. GiU, Ind. Eng. Chem. 1933, 25, 49.  
 42 H. R. Brown et al., Rep. Inve&t. R.I. Bur. Mines, U.S. Dept. Int. 1942.  
 43 H. M. Langton, "Blacks and Pitches," Ernest Benn, Ltd., London, 1925.  
 44 E. Donath and B. M. Margosches, Chem. Ind. 1904, 27, 220.  
 45 M. Klar (Trans. by Rule), "Technology of Wood Distillation," Chapman and Hall, London, 1925.  
 46 A. O. Allen et al., Off. Digest, 1943, 2, 396.

E. V. E.

**PITCHBLENDE** is the name applied to the massive, colloform variety of *uraninite*, on account of its pitch-like lustre on a "freshly-broken surface. The mineral *uraninite* crystallises in the cubic system, though crystals are rare; the massive, botryoidal and colloform variety (*pitchblende*) is much more common. *Pitchblende* is a complex oxide of uranium with small amounts of lead and the rare elements, radium, thorium, yttrium, lanthanum, helium, etc. It is structurally identical with *uraninite*, which consists essentially of uranium dioxide,  $UO_2$ . Natural *uraninite* (including *pitchblende*) is invariably more or less oxidised, and its actual composition lies between  $UO_2$  and  $U_3O_8$ . Lead is always present as the stable end-product of the radioactive disintegration of both uranium and thorium. Although crystalline *uraninite* may contain up to 14% of thorium, this element occurs in *pitchblende* only as traces. Helium, a gas first discovered in *pitchblende*, is

invariably present as a product of radioactive disintegration.

The principal constituents in a *pitchblende* from Johanngeorgenstadt, Saxony, were:  $UO_2$  59-30,  $UO_3$  22-33,  $PbO$  6-39,  $H_2O$  3-17,  $As_2O_3$  2-34, and  $CaO$  1-00%. The  $H_2O$  is probably due to alteration,  $As_2O_3$  and  $CaO$  are almost certainly the result of impurities, and the  $UO_3$  content of the mineral is thought to be due to an oxidation process, or autoxidation promoted by radioactive decay.

*Pitchblende* has a velvety black colour, a brownish-black streak, and a characteristic greasy or pitchlike lustre. It is brittle, has a hardness of 5½, and density ranging from 6.5 to 8.5 (whereas crystalline *uraninite* has  $\rho$  from 8.0 to 10.0). The mineral occurs as a primary constituent of granitic rocks and associated pegmatites, and in certain metalliferous veins containing lead, cobalt, nickel, silver, and tin minerals deposited from hydrothermal solutions. The *pitchblende* deposit of Great Bear Lake, Northwest Territories, Canada, discovered in 1930, is probably the richest and largest source of uranium and radium in the world. Here the *pitchblende* represents colloidal deposition in cavities, and is accompanied by native silver and cobalt-nickel arsenides, the ore mineralisation being related to granitic intrusives. Until the discovery of the Canadian deposits, the ores of Chinkolobwe in the Katanga district of the Belgian Congo were the chief source of the world supply of radium and uranium. Here the ores consist of *pitchblende* together with its brightly coloured oxidation products, including the orange gummite and the reddish-brown *clarkeite*. The famous mines at Joachimsthal in Czechoslovakia, well known as the source of the *pitchblende* from which Madame Curie first extracted radium, still yield valuable quantities of radium and uranium.

Until a few years ago *pitchblende* and other uranium ores were mined not so much for the metal itself as for their radium content. Salts of uranium have, however, long been used for making iridescent glass, for imparting yellow and brown tints to glass, porcelain, and pottery, as mordants in dyeing and calico-printing, and in photography. On an average 750 tons of *pitchblende* ore are needed to produce about 5 tons of uranium salts, or 1 g. of a radium salt. With the explosion of the atomic bomb on Hiroshima in 1944 the public became aware of the prodigious amount of energy pent up inside the uranium atom, and there can be little doubt that in the future the principal use of uranium derived from *pitchblende* will be, in the realms of atomic energy. About 0.7% of uranium consists of the isotope  $^{235}U$ , 1 lb. of which is said to contain latent energy equivalent to the power developed in burning nearly 2,500 tons of coal. Radium, which is obtained almost wholly from *pitchblende* or *uraninite*, is mainly employed in curative medicine, especially in the treatment of cancer and skin diseases. Luminous paints for dials, signs, gun-sights, etc., consume about a tenth of the total annual world production of about 200 g., and small amounts of the metal are used for detecting inner flaws in metal castings and forgings. Canada and the Belgian

Congo are the chief producers of radium and uranium, but recent production figures are not available.

**Reference.**—C. Palache, H. Berman, and C. Frondel, "System of Mineralogy," 7th ed., Vol. I, New York; 1944, pp. 611-620 (contains numerous analyses and a valuable list of references).

D. W.  
**PITUITARY BODY** (*Hypophysis cerebri*, *Hypophyse* Fr., Ger.) is a small gland situated at the base of the brain in vertebrates. It consists of two developmental<sup>^</sup> distinct portions, the anterior and posterior lobes; in some animals, including man, there is a third (*pars intermedia*). The gland is the source of a number of hormones essential to life and it is significant that it occupies a particularly well protected position in the body.

The pituitary has been the subject of intensive research since Oliver and Schäfer first discovered that extracts of the gland caused a rise of blood pressure on injection (J. Physiol. 1895, 18, 277). An even more important effect is that on the uterus, discovered by Dale (Biochem. J. 1909, 4, 427) and utilised for clinical purposes by Bell (Brit. Med. J. 1909, ii, 1609). For this reason various pituitary preparations have been put on the market; these include *Hypophysis sicca*, U.S.P. 1926, consisting of posterior lobes of cattle pituitaries, cleaned, dried, and powdered; *Extraction Pituitarii liquidum*, B.P. 1932, which is prepared from posterior lobes of cattle pituitaries by extraction with hot dilute acetic acid (pH 3-4) and is assayed on the isolated uterus of the guinea-pig by comparison with an extract of acetone-extracted dry, powdered standard substance; and *Liquor Pituitarii*, U.S.P. 1926, which is tested against a standard prepared from at least 25 pituitaries of cattle by Voegtlin's method (0.5 mg.=1 international unit).

Recent work shows that from the posterior lobe of the pituitary three active principles can be extracted: vasopressin or pitressin, responsible for the ability of extracts to raise blood pressure, oxytocin, or pitocin, responsible for the action on the uterus, and a substance controlling the activity of the kidneys (antidiuretic principle), although the last effect may be due to pitressin and not to a separate hormone. They are obtained in most cases by the extraction of acetone-dried posterior lobes with dilute acetic acid, followed by precipitation with organic solvents, the precipitate being dissolved in strong acetic acid and again precipitated; fractional precipitation with salts is also employed (Kamm *et al.*, J. Amer. Chem. Soc. 1928, 50, 573; Bugbee and Kamm, Endocrinology, 1928, 12, 671; Stehle and Fraser, J. Pharmacol. 1935, 55, 136; Irving, Dyer, and du Vigneaud, J. Amer. Chem. Soc. 1941, 63, 503; the various methods are critically reviewed by Irving and du Vigneaud, Ann. New York Acad. Sci. 1943, 43, 273). A promising method for the separation of the oxytocic and pressor principles is chromatographic adsorption on artificial zeolite\* used by Potts and Gallagher\* (J. Biol. Chem. 1941, 140, ciii; 1942, 143, 561), whose preparations appear to be the most active yet obtained (activity 450 pressor units and 700

oxytocic units per mg. respectively). These preparations are almost colourless, hygroscopic powders, evidently polypeptides of a molecular weight of 600-2,000 (Irving and du Vigneaud), stable in dilute acid and decomposed by alkali. Pitressin is hydrolysed to tyrosine, cystine, arginine, proline, and foleucine, whilst -- in pitocin leucine takes the place of isoleucine; both give colour reactions for tryptophane (Stehle and Triste-, J. Pharmacol. 1939, 65, 343). Potts and Gallagher (*I.e.*) find that the pressor fraction yields, more arginine than the oxytocic. Histidine and choline have been found amongst the hydrolysis products of pitocin (Freudenberg, Weiss, and Biller, Z. Physiol. Chem. 1935, 233, 172); the same authors find\* that pitocin is inactivated by tyrosinase, which suggests that the phenolic grouping of tyrosine may be essential for oxytocic activity.

The early suggestion of Abel (J. Pharmacol. 1930, 40, 139) that the various effects of the posterior lobe, were due to one hormone consisting of a "mother molecule" from which pitocin, pitressin, and the antidiuretic factor were derived by fission has recently been revived; a preparation possessing pressor, oxytocic, and renal activity in equal measure has been obtained by van Dyke, Chow-Greep, and Rothen (*ibid.* 1942, 74, 190) by suspending fresh ground posterior lobes of oxen in cold 0.01 N. sulphuric acid, centrifuging off inert material, and salting out with 8% of sodium chloride at pH 3.9. The precipitate was further fractionated by precipitation with various concentrations of salt until a homogeneous product was obtained, as evidenced by constant solubility, electrophoresis, and ultracentrifugation data (0.7 g. from 1 kg. of glands). This had an isoelectric point at pH 4.8 and a molecular weight of about 30,000 (determined by the ultracentrifuge) or 26,000 (from the amino-nitrogen value, assuming one free amino group per molecule).\* The material contained little phosphorus and a high percentage of cystine (16%), reduction of which caused almost complete loss of activity; the oxytocic activity was destroyed by trypsin and chymotrypsin, but not by pepsin.

The *pars intermedia* of the pituitary produces only one hormone, the function of which in higher animals is not fully understood; in amphibia it causes the dispersion of the black pigment granules in the epidermal melanophores. An almost pure preparation of the hormone has recently been obtained (Landgrebe and Waring, Quart. J. Exp. Physiol. 1941, 81, 31).

The anterior lobe of the pituitary is rich in hormones: six of these\* are generally accepted, namely the growth hormone, two gonadotropic\* hormones, the lactogenic hormone, the thyrotropic hormone, the adrenocorticotrophic hormone; there may be a metabolic hormone. These are all proteins in character and at least one has been isolated in the pure state, others nearly so.

**The growth hormone is obtained by extracting anterior lobes with either neutral or mildly**

\* In the more recent reviews the terms gonadotrophic, thyrotrophic, etc., have been used in place of gonadotropic, etc. The older term has been retained in the present article for the sake of uniformity.

alkaline solutions (barium or calcium hydroxides, sodium chloride) and is freed from accompanying hormones by various methods, including ultracentrifugation at a definite pH (White and Bonsnes, *Endocrinology*, 1940, 26, 990), but a pure preparation has only recently been obtained (Li and Evans, *Science*, 1944, 99, 183; Li, Evans, and Simpson, *J. Biol. Chem.* 1945, 159, 353). The most active preparations have a molecular weight comparable with that of egg or plasma albumin, are destroyed by heat and proteolytic enzymes, and are apparently more stable to alkalis than acids. Administration of the hormone produces a remarkable stimulation of body growth leading to gigantism (c. Svans^ aZ, *Mem. Univ. California*, 1933^ 11, 446).

The gonadotropins are distinguished as the follicle-stimulating hormone (FSH), causing growth of ovarian follicles and of the male germ cells, and the interstitial-cell stimulating or luteinising hormone (ICSH, LH), which causes the growth of corpora lutea in immature female animals and the growth of seminal vesicles and the prostate in males. These gonadotropins correspond roughly to Prolan-4 and -B of Zondek (see Horntnes, Vol. VI, 266-7, but the term Prolan-4 has been abandoned because it had also been applied to a hormone extracted from pregnancy urine which has since been shown to originate in the placenta (chorionic gonadotropin, PU) and to have no action on hypophysectomised animals. A potent gonadotropin (PMS) has also been obtained from the serum of pregnant mares; it is said to be derived from the endometrium (H. H. Cole and H. Goss, "Essays in Biology," University of California Press, 1943, p. 103).

FSH occurs in the urine of women after the menopause, but has not been isolated from it in the pure state; the best sources are sheep or hog pituitaries. It is assayed by the increase in weight of ovaries of hypophysectomised animals; if purification is complete, the preparation does not cause the formation of corpora lutea in such animals, an effect due to ICSH. Three groups of workers claim to have isolated substantially pure FSH (Greep, van Dyke, and Chow, *J. Biol. Chem.* 1940, 133, 289; *Endocrinology*, 1942, 80, 635; Jensen, Tolksdorf, and Bamman, *J. Biol. Chem.* 1940, 135, 791; Fraenkel-Conrat, Simpson, and Evans, *Proc. Soc. Exp. Biol. Med.* 1940, 45, 627). ICSH has been isolated by Van Dyke *et al.* and by Evans *et al.*, who regard their preparations as pure on the strength of electrophoretic, ultracentrifugal, and solubility data, while Fevold (*Ann. New York Acad. Sci.* 1943, 43, 321) has obtained an even more potent preparation of ICSH which is not, however, claimed to be a pure protein. In the same paper a comparison of the different methods of isolation is given; these are based on the extraction of the glands with dilute sodium chloride or with 40% alcohol, followed by fractional precipitation. For the final separation of FSH and ICSH advantage is taken of the different solubilities of the two gonadotropins in solutions of ammonium sulphate (Fevold) or sodium sulphate and acetate buffer (Chow, *ibid.* p. 309). It

should be noted that as the starting materials of the different groups of workers and also their methods of assay are different, their results are not strictly comparable, especially in view of the undoubted species specificity of several of the pituitary hormones (c. Fraenkel-Conrat, *Annual Review Biochem.* 1943, 12, 273). The gonadotropins are both glycoproteins although they differ in their carbohydrate content; they are inactivated by proteolytic enzymes and by keten, FSH also by cysteine (Chow, *l.c.*). The secretion of gonadotropins can be influenced by the administration of steroid sex hormones, but the relationship is not a simple one.

Prolactin (mammotropin, lactogenic hormone) is the hormone responsible for mammary growth and lactation, although it is only active after previous treatment with oestrogens; it can be assayed owing to its action on the crop gland of pigeons and appears to be the hormone responsible for "broodiness" or nesting instinct of birds and the maternal instinct of *Tran. Biol.* It has been obtained pure (c. White, *Ann. New York Acad. Sci.* 1943, 43, 341) by precipitation of an acid-acetone extract of beef pituitaries with acetone (the method originally due to Lyons, *Proc. Soc. Exp. Biol. Med.* 1937, 35, 645), the precipitate being extracted with water and again precipitated. An alkaline extract of this preparation is adjusted to pH 6.6 and treated with ammonium sulphate, precipitating the adreno-corticotrophic fraction, the solution adjusted to pH 5.4, and the precipitation repeated several times. Finally, salts are removed by dialysis and the substance dried with acetone. It can be crystallised, but this does not increase the activity and repeated crystallisation appears to denature it. The isoelectric point of prolactin is pH 5.7 and the molecular weight about 35,000 (by sedimentation), while calculations based on the amino-nitrogen content give a lower value, 25,000. Prolactin is digested by both pepsin and trypsin and is inactivated by keten and nitrous acid. On hydrolysis it yields 5.5% tyrosine, 3.4% cystine, 4.3% methionine, and 8.3% arginine (Li, Lyons, and Evans, *J. Biol. Chem.* 1941, 140, 43); the sulphur content is about 2% (White, *l.c.*).

A connection between the function of the pituitary and the thyroid in a number of animals has been known for some time and there is evidence to show that a pituitary hormone affects the thyroid by way of the blood stream without the intervention of the nervous system. The isolation of the thyrotropic hormone is due to several groups of workers (Fevold; Jensen; White; and Fraenkel-Conrat, with their associates) and the purest so far obtained behaves as a homogeneous compound in the sedimentation test and in the ultracentrifuge. This was prepared by the extraction of frozen and ground pituitaries with 2% sodium chloride at pH 7.8, removal of accompanying products by precipitation with acetone at pH 4.1, and the addition of more acetone, which brings down the thyrotropic hormone. The solid was again dissolved in water, more material removed by 5% lead acetate at pH 7.0, then with trichloroacetic acid, the solution being finally purified by dialysis and concentrated (Ciereszko and White, *Federa-*

tion Proc. 1942, 1, 105). The dry product is a white solid, which is a protein and gives a positive carbohydrate test. It is suggested that the action of the hormone consists in the control of the iodine uptake by the thyroid gland and of the conversion by the latter of di-iodotyrosine into thyroxine, a view supported by experiments with radioactive iodine (Morton, Perlman, and Chaikoff, *J. Biol. Chem.* 1941, **140**, 603).

Removal of the hypophysis leads to degeneration of certain portions of the adrenal cortex giving rise to symptoms of adrenal deficiency and emaciation. The opposite symptoms, *i.e.*, adiposity (Cushing's syndrome), are found associated with tumours of the adrenal cortex or of the anterior lobe of the pituitary. The symptoms of emaciation are alleviated by the administration of pituitary extracts and the most potent fractions are contained in the mother liquors of the thyrotropic hormone (adrenocorticotrophic hormone, ACTH). From

these products were ultimately obtained which behaved as homogeneous compounds as regards solubility and on electrophoresis and ultracentrifugation. They had a molecular weight of the order of 20,000 and an isoelectric point at pH 4-7 (Bates, Riddle, and Miller, *Endocrinology*, 1940, 27, 781; Li, Simpson, and Evans, *Science*, 1942, 96, 450).

The existence of a separate metabolic hormone in the pituitary has been the subject of much work, but cannot be regarded as certain; a number of other functions of the gland in ~~regulating different vital processes~~ are beyond the scope of this article.

#### REFERENCES.

For more detailed and later references, see Annual Review of Biochemistry, and also H. B. van Dyke, "The Physiology and Pharmacology of the Pituitary Body," Chicago, 1936 and 1939; A. T. Cameron, "Recent Advances in Endocrinology," 6th ed., London, 1947.

G. A. R. K.

# INDEX TO VOLUME IX

- A**
- Absorbents for petroleum, 498d  
**Acetone**, 286(2)  
**Acetylene** from cracking, 374a  
 — natural gas, 397a  
 Acid peroxides, 49a\*, 2996, 5086, 606a  
**Actinometry**, 533a  
 Activation overpotential, 141c, 142c  
 "Adurol" reagent, 179(2)  
 Agaricides, 312(2)  
 Air liquefaction (*see also* Liquefaction of Gases, Vol. VII, 333a; Oxygen production this Vol. 1826), 182c  
 —, Joule-Thomson effect in, 141c  
 —, Linde's process, 182c  
 Alcohols, fish oil, batyl, 356  
 "Aldehyde peroxide", 2985  
 Alkylation of jfcytane, 359a  
 — with aluminium chloride catalyst, 3606, 3626  
 — hydrogen fluoride catalyst, 359(2)  
 — sulphuric acid catalyst, 359a  
 Allanite, 1316  
 isoAlloxazine, 165c  
 Alloys, amorphous material in, 127a  
 —, atomic structure, Bragg-Williams theory, 128a  
 —, critical temperature, 124a, 1266, 1286  
 —, heating curve and critical temperature, 124a, 1256, d, 126a, 6, 1286  
 —, order-disorder transformation in, 121a  
 —, specific heat - temperature curve, 126a, 127a, 128a  
 AUyl propyl disulphide, 93d  
 Almond and apricot kernel oils, 22a, 53a, 55a  
 Alpha-tocopherol, 474c  
 Aluminium as pigment, 6416  
 Ambergris odour, 2916  
 Axnbretolide, 2916  
 Ammonium chloropalladate, 211a  
 — peroxide, 292c  
 Axnphotic oxides, 176z  
 Amyl alcohol, 288c  
 o - n - Amylcinnamaldehyde, 286a  
 Anaerobic organisms, 1786  
 Analysis by hydrogenation (*see also* Vol. II, 6226; VI, 359c), 1806  
 Aneurin, 165c  
 Animal depot fats, component acids, 7a  
 Anisaldehyde, 285(2)  
 Annatto, detection, 73a  
 Anopheline - mosquito control, 303a  
 Anthraquinone BGG, 151(2)  
 Anthraquinones, substituted, 609a  
 Anti-knock, iron pentacarbonyl, 381c  
 Antimony oxalates, 149a  
 — oxide, 6276  
 "Anti-oxidants" in fat, 266, 486  
 "Antipyrin", 466c  
*Anamirta paniculate*, 620(2)  
 "ANTU" or "109", 3146  
 Apiole, 90c, 2336  
 Apionol, 478e2  
 Apparent molar quantities, 2376  
 Vachidic acid, 686  
 Arachidonic (eicosatetraenoic) acid, 15c  
 Arachis oil, 29b\*, 55a, 686  
 Arrack, 212a  
 Argemone oil, 27c  
 Aromatics, 356(2)  
 — from dehydrocyclisation, 356a  
 Arrhenius theory, 420(2)  
 Arthropod pests, 301(2)  
 Asbestine, 631a  
 Ascaridole, 295(2)  
 Asebotin, 482a  
 Asphalt, 394c  
 — tests, 3956  
 A.S.T.M., 3794  
 Atomic arrangement and critical temperature (*see also under* Alloys), 1256  
 — body-centred and face-centred cubic lattices, 121c  
 — disorder and heating curve  
 • of alloys, 125(2)  
 — solid solution, 121c  
 —, electrical resistivity of, 125a  
 — superlattice types, 121c  
 — superstructure, 124a, 1286, d  
 Ave-Lallemant Baryta Value, 69a  
 Avocado pear oil, 22a  
 Azo-dyes, detection, 73c
- B**
- Babassu fat, 176  
 Bagilumbang oil, 28a  
 "Bakelite", 390c  
 Baku Dumori fat, 206  
*Balaena* whale oil, 35c, 36c  
 Ball mill, 204(2)  
 Balsam, gurjun, 89(2)  
 Balsams, 89c  
 Barium carbonate, Witherite, 630c  
 — chromate, 635a  
 — sulphate, Barytes, 630a  
 Barytes, microfiltered, 6306  
 Baudouin test, 71(2)  
 Beef tallow, characteristics, 296, 63d  
 Beef tallow, component acids, 7a, 286, 30a  
 Beer-Lambert law, 541(2)  
 Bentonite, 6316  
 — clays, 369d  
 Benzaldehyde, 284c  
 "Benzedrine", 162a, 1676  
 Benzoylacetone, 2876  
 Benzylacetone, 287a  
 Benzyl alcohol, 282c  
 — esters in perfumery, 2886  
 Benzylideneacetone, 287a  
 Betel nut fat, 176  
 Bieber test, 72c  
 "Bios", 214a  
 Biotin, 212c  
 Black, Acetylene, 6406  
 —, Aniline, 647a  
 —, Bone or Ivory, 640c  
 —, Carbon or Gas, 639c  
 —, Drop, 640c  
 —, Ilmenite, 6416  
 —, Lamp or Vegetable, 6396  
 — lead, 640(2)  
 — oxides of iron, 633a, 634a  
 —, Thermatomic, 6406  
 "Blackmail reaction", 595(2, 5976  
 "Blacken", 312a  
 Blanc Fixe, 6306  
 Bleaching of paper, 219(2)  
 Blue, Capri, GON, 180c  
 —, Meldola's, 150(2)  
 —, Methylene, hydrogen acceptor, 1626  
 —, Monostral Fast, B, 6196  
 —, New Methylene, GG, 1516  
 —, Nile, A, 1516  
 —, Brunswick, 837(2)  
 —, Cobalt, 637a  
 —, Prussian, 6376  
 Blues, copper, 6376  
 Blue, Sirius Brilliant, FFB, 152(2)  
 —, Soluble, 637(2)  
 —, Ultramarine, 636(2)  
 — value, 73a  
 Boltzmann law, 244(2)  
 Bone grease, 29(2, 406  
 Borneo tallow, 20a, 53c, 54c  
*Brassica spp.* oils, 23a  
 Brewster angle, 116(2)  
 Bromine value, 60(2)  
 £-Bromostyrene, 290c  
 Buffered solutions, 423a  
 "Buna<sup>M</sup>-N, rubber, 397c  
 — S rubber, 387c  
 Burnt Ochre, Ochre, 632a  
 — Sienna, 625c  
 —, Sienna, 6326  
 3 Umber, Umber, 632(2)  
 Butadiene rubber, 397c  
 n-Butane isomerised to isobutane, 348c  
 isoButane, thermal alkylation of, 3576  
 Butter (*see also* Cow Butter, Cow milk), 16a  
 "Butyl", 352(2)  
 Butylene, products from, 397c  
 p-ferf.-Butylphenol and resin, 473(2)

- C**
- Cacaó bean shell fat, 166  
 — butter, 106, o\ 20a, 53c, 54c  
 — substitutes, 20a  
 Calcium peroxide, 2924  
 — chromate, 635a\*  
 "Calgon" water - softening, 510(2), 514a  
 Canada Balsam, 89c  
 Candlenut (lumbang), oil, 26c, 27b  
 Capillary fragility, 2016  
 Capsicine, 90a  
 Carbon disulphide fumigant, 3126  
 Carbonic acid titration, 421a.  
 Carboxylase, 165b  
 Carmine, 642c  
 Carotene, 42d  
 Carvacrol, 474(2)  
*Caryocar* spp., 16b  
 Cashew nut oil, 23a  
 Castor oil, 236, 53a, 55c  
 —, hydroxy-acids, detn., 64c  
 —, sulphated, 51b  
 Catalase, 165b  
 — haematic, identity with haematin of haemoglobin, 165(2)  
 — spectrum, 165(2)  
 Catalyst, olefin, giving codimer, 351d  
 —, —, "solid phosphoric acid," 350b  
 —, —, sulphuric acid, 349a  
 —, —, pyrophosphate, 353a  
 Catalysts, clays and fuller's earth, 353a  
 "Catalpo," 631b  
 Catechol, 475b  
 "Cellophane," 232(2)  
 Cells, standard, 417(2)  
 Cetane or cetene number, 386a  
 C.F.R., 379d  
 Chain reactions, 535b  
 Ghaulmoogra nil, 9b, 12b, 21a, 53a  
 Chaulmoogric acid synthesis, 12b  
 Chavicine, 279a  
 Chemical potential, 237(2), 238c  
 China & clay, Kaolin, 631a  
 — wood oil, *see* Tung oil  
 Chinese vegetable tallow (*Stillingia*), 16b, 27a  
 Chlorophyll-a (*see also* Photosynthesis), 592(2)  
 Chlorophyll-b, 593b  
 — and gaseous exchanges, 596b  
 — induction periods, 595c  
 — "kinetics," 694(2)  
 — reactions in leaf, 593c  
 —, synthetic product of, 596(2)  
 Cholesterol, 31b  
 Chromazurine E, 152a  
 Chrome pigments, 634b  
 Chromes, zinc, 635b  
 Chiysolite, 93b  
 Cxnamaldehyde, 286a  
 Cinnamon fat, 19a  
 Cinnamyl alcohol, 282(2)  
 "Citrin," 201b, d  
 Citronellol, 282a  
*Citrus aurantium*, 119c  
 Civetone, 290(2)  
 "davacin\*," "clavatin"; "calviformin," "expansin," 252(2)  
 "Glupanodonie odd/" 15a
- Coal gasification underground, 182a  
 — oil, 389c  
 Coal-tar briquettes, 653c  
 — pitch (*see also* Pitch), 650(2)  
 — as binder, powdered fuel, 654a  
 —, composition, 652(2)  
 —, density, 652a  
 Cocarboxylase, 165b, c  
 Cocoa butter, (*see* Cacao butter)  
 Coconut and palm-kernel oils, reduction to alcohols, 17c\*  
 —, substitutes, 18b  
 — oil, 17b, 18b, 53c, 54a  
 —\*J crude, refined olein, refined stearin, 54a  
 — extraction, 38ft  
 "Coconut stearin/" 17c, 54a  
*Cocos nucifera*, lib  
 Codamine, 104a, 112(2)  
 Codeine, constitution, 105d; 106c, 109a  
 —, detection, 108(2)  
 —, extraction, 102b, 103b, o  
 —, properties, 108b  
 Cod-liver oil, characteristics, 34a, 53a, 54a  
 —, component acids, 12c, 15b, 34a  
 — esters, separation, 15b  
 —, occurrence, 6a  
 — vitamins, 7(2), 34c, 35b  
 Coenzymes, 162c  
 Cohune fat, 17b  
 Cold evaporator, 181c  
 Colour photography, 577a  
 — sensitometry, 570a  
 Colza oil, *see* Rape oil  
 Combustion, theories of, 178a  
 —, *Commission Internationale de* Clarage standards, 578b  
 Concentration polarisation, 141c  
 —, abnormal, 142c  
 Conjugated unsaturation, detn., 2(2), 14c, 27(2), 61c  
 Copaiba Balsam, 89(2)  
 Copper bronze, 641(2)  
 Copra, 38b, 39a  
 Corrosion, 178a  
 — inhibiting, 514a  
 Gotarnine, 111d  
 —, synthesis, 111(2)  
 Cottonseed oil, 24b, 53a, 55a  
 Coumarin, 290b  
 Cow butter, characteristics, 31c, 53b, c  
 —, component acids, 8a, 31c, 32a, 33(2)  
 — values, 31(2)  
 — milk, effect of feed on, 33a  
 — glycerides, 33b  
 Cozyznase, 162c  
 — and respiration, 163c  
 — in metabolism, 163b  
 Cracked gasoline, gum in, 363b  
 Cracking catalysts, 347c  
 —, catalytic, 340b  
 —, —, fixed bed, 341c  
 — for oledns, 373d  
 — furnaces, 339c\*  
 — gases, 348b, 353b, 372(2)  
 —, moving bed, 341(2)  
 — reactions, 346a  
 †1 *Cratagon*, 286(2)
- Cresols, detn., 472(2)  
 p-Crosyl methyl ether, 283a  
 Cryptopine, 103(2), 104a, 114c  
 Crystallisation, 488o  
 Cubebin, i)0a  
 Cubebs oleo-resin, 90a  
 Cuminol, 474c  
 Custard apple, 254c  
 "Cyanidin reagent," 259c  
 "Cyanogas," 312a  
 Cyclamen aldehyde, 286b  
 'Cyclic mono-, di-, and polyolefins, 89c
- D**
- DBP, 312-2  
 DDT, 309a, 400b  
 Debye-Hückel activity equation, H1tf  
 n-Decaldehyde, 284a  
 J°-Decenoic acid, 13a  
 rz-Decyl alcohol, 281d  
 Dehydrogenase reactions, 161 &  
 Dehydrogenases, 160a  
 — and ilayoproteins, 164c  
 — respiratory equilibrium, 161a  
 — SH groups, 162b  
 —, coenzymes, 18?c  
 —, equilibria, 160c  
 —, inhibitors, 161c  
 —, specificity! lola  
 Dehydrogenase systems and hydrogen acceptors, 162b  
~~Dehydrogenation~~ 853b  
 Delphinidas oils, 6c/7a, 36(2, 37a  
 "Delphinidin reagent," 259c  
 "Dephlogisticated air," 168(2)  
 Detergents from petroleum, 400a  
 Dialkyl peroxides, 297a  
 aS-Diamino - n - valeric acid, 129b  
 Diaphorases, 164a  
 Diastereoisomers, 117(2)  
 Diatomite, 97(2)  
 2\2-(pp' - Dichlorodiphenyl) - 1:1:1 - tricoloroethane | 309a,  
 \* *Dicodidk*, 109-2  
 Diels-Alder condensation, 14c, 61c  
 Diene Value, 61c  
 Diesel fuel, 385b  
 — promoters, 386b  
 Di-ethylidene peroxide, 298b  
 Dihydr ocinnamaldehyde, 286a  
 Di (hy dr oxymethyl) peroxide, 297d  
 9:10-Dihydroxystearic acid from oleic acid, 11e  
 Dika fats, 19a  
 "Dilaudide," 106b  
 3:7-Dimethyl - octan - 1 - ol, 282a  
 Dimethyl peroxide, 297b  
 Dioleflns, 89c, 354(2)  
 — and polyolefins, 89c  
 "Dionine," 105(2)  
 Diphenoxazines, preparation, 150a  
 —, structure, 150a  
 Diphenylamine, 290c  
 Diphenyl ether, 283a  
 Dissociation of electrolytes (Arrhenius), 97a



- Dissociation of weak electrolytes (Onsager), %la  
 Distemper finish, 206(2)  
 DMP, &2»  
 \* Doctor solution, 368a  
 n-Dodecaldehyde, 284a  
 Dolphin and porpoise fats, 36Z, 87a, 54c  
 Dunite refractories, 036  
 Dyes and stains, 623d
- E**
- Edeleanu solvent, 3706  
 Edge-runner, 205a  
 Eggshell finish, 206c  
 Einstein unit, N, 626c  
 Elaeostearic acid isomers, 146  
 —, structure, 96, 136  
 —, ultra - violet absorption, 2d, 276  
 Elaidic acid, 116  
 Elasmobranch fish oil, 66, 12a, 356  
 Electrode, arbitrary zero, 1546, c  
 Electrodeposition overpotentials, 1466  
 Electrode, zero, in Lewis activity theory, 1540  
 Electron microscope, 239c  
 Electron-volt, 526c  
 "Enzyme, respiratory," 1666  
 Enzymes, copper-containing, 1666  
 —, iron-containing, 1656  
 —, oxidising, 159(2)  
 —, respiratory, 160a, 166c  
 Ephedrine, enzyme inhibition by, 1676  
 Eriodictin, 2016, d  
 Esparto and straw pulp, 217c  
 Essang oil, 28a  
 Esters in perfumery, 288a  
 Ethylene and polyethylene, 856  
 Ethylidene peroxide, 298a  
 Ethylvanillin, 285(2)  
 Eugenol, 290(2)  
 "Exaltone," 291a  
 Extenders, 203a, 623c, 629(2)  
 Extinction coefficient, molar, 2d, 542a \*
- F**
- Factice, 526  
 "Fadometer," 686(2, 587a)  
 Farnesol, 2826  
 Fat analysis, acetyl value (see also names of authors and tests), 65a  
 —, acid value and free fatty acids, 62c  
 —, ash, dirt, sea water detn., 576  
 —, Ave - Lallemand Baryta Value, 69a  
 —, bibliography, 80a  
 —, fluorescence method, 79a  
 —; j 5 r \* o k e e p m g Properties, 75d, 76a  
 —, insoluble bromine compounds, 61(2)  
 —, metallic impurities detn., 596  
 —, oil "break," 41a, 69a  
 —, oxidisability value, 75(2)  
 —, sampling, b66
- Fat analysis, saponification value, 59(2)  
 —, solidifying point, 77(2)  
 —, specific tests, 53a, 56(2)  
 —, sterol acetate, 646  
 —, Thiocyanogen Value, 606, 616  
 —, titre point, 77(2)  
 —, unsaponifiable matter, 72a, 63a  
 —, water detn., 56c  
 Fats, see also Fat analysis; Fatty acids; Oils  
 —, action of sulphuric acid on, 51a  
 —, animal depot, component acids, 7a  
 —, extraction in autoclaves, 406  
 —, —, water absent or present, 39(2, 40a)  
 —, aquatic organisms, 5(2)  
 —, bleaching, adsorption methods, 43a  
 —, —, oxidation methods, 43(2)  
 —, —, with sulphuric acid, 4a  
 —, bulk weight, 786  
 —, colour measurement, 79c  
 —, —, photoelectric, 79(2)  
 —, component glycerides, 36, 46  
 —, containing tovaleric acid, 5c, 36(2)  
 —, cooking, 546  
 —, definition, le  
 —, deodorisation, 446  
 —, "dry rendering," 30(2)  
 —, extraction by pressure, 38c, 40c  
 —, —, solvents, 39a  
 —, —, decortication in, 386  
 —, —, expeller presses, 38(2)  
 —, —, from nuts and seeds, 38a  
 —, —, vegetable pulp, 37d  
 —, —, ("rendering"), 37a  
 —, —, solvents, 39a  
 —, hydrolysis by alkali, 49a  
 —, —, enzymes, 44c  
 —, —, lipase, 46(2)  
 —, —, sulphuric acid, 466  
 —, —, water, 45(2, 466)  
 —, land animal (see also Cow butter, Cow milk), 10a  
 —, liquid vegetable, 16a  
 —, liver, source of vitamins-J. and -D, 1d  
 —, mammalian milk, 8a, 31c, 32a, 33(2)  
 —, marine fish (body or liver), 16a, 34a  
 —, marine mammalian, 16a, 35c \*  
 —, melting-point, 76(2)  
 —, of freshwater organisms, 6a  
 —, marine organisms, 6a  
 —, optical dispersion, 796  
 —, —, rotation, 13c, 21c  
 —, orange or yellow dyes in, 736  
 —, ox, pig, and sheep depot, 306  
 —, "plasticised," sp.gr., 79a  
 —, rendering, 40r  
 —, —, by neutralisation, 41a  
 —, —, removal of suspended non-fats, 40(2)  
 —, —, tests of 59c  
 —, refractive index, 79a  
 —, seed, chaulmoogra group, 12(2, 21a)
- Fats, seed, occurrence of fatty acids of, 9a  
 —, —, rich in arachidic acid, 20(2)  
 —, —, lauric and myristic acids, 18c, 19a  
 —, —, lignoceric acid, 21a  
 —, —, palmitic acid, 18(2, 196)  
 —, —, stearic acid, 18(2, 20a)  
 —, separation in molecular stills, 42c  
 —, site, in organism, 1(2)  
 —, smoke, flash and fire points, 79c  
 —, solid fruit-coat, 16a  
 —, —, land animal body, 16a  
 —, —, vegetable, 15(2)  
 —, sources, *Bombacaceae*, *Compositae*, *Gramineae*, *Labiatae*, *Idnaceae*, *McUvaceae*, *Rosaceae*, 8cJ  
 —, specific gravity, 786  
 —, synthesised *in vivo*, 76  
 —, technically valuable, 15c  
 —, triglycerides, analysis by hydrogenation, 3c  
 —, —, oxidation, 36  
 —, —, bromo-addition products, 4(2, 136, 146)  
 —, —, calculated composition, 4(2, 56)  
 —, —, components, 36, 46  
 —, —, major component acids, 5c  
 —, —, minor component acids, 5c  
 —, —, rule of even distribution of fatty acids, 46, 6(2)  
 —, Twitchell hydrolysis, 46c  
 —, unsaturated, additive halogen products (see also Oils, drying), 51c  
 —, —, with oxygen, 47a  
 —, —, hydrogenated, 51a  
 —, —, oxidation catalysts for, 48a  
 —, —, inhibitors, for, 266, 486  
 —, —, —, 47a, 48a  
 —, —, —, to peroxides, 476  
 —, —, photochemical oxidation, 48a  
 —, —, reactions with sulphur and sulphur chloride, 52a  
 —, —, thiocyanogen, 52a, 616  
 —, —, vegetable, effect of climate on, 19a  
 —, —, viscosity, 796  
 Fat triglycerides, analysis by crystallisation, 2(2)  
 Fatty acids, autodecayed, 46a  
 —, diethenid, 7a, 13(2)  
 —, —, ultra-violet absorption, 2(2, 14a)  
 —, highly unsaturated, 106, 14(2)  
 —, —, in fats of aquatic animals, 5(2, 34a)  
 —, —, fruit-coat fats, 86, 9a, 16a, 18c  
 —, —, land animal (*settaUò Con butter*), 6c  
 —, —, marine animal, 6a, 7a, 12a, 14(2)  
 —, —, monoethenoid, 11a, 12a  
 —, —, m.p.'s, 10(2)

- Fatty acids**, polyethenoid, 13d  
 —, —, detn. by extinction coefficients, 2d, 14c, 27d  
 —, —, — with maleic anhydride, 14c, 61c  
 —, —, marine animal, *lid*  
 —, —, vegetable, 13d  
 —, —, removal by distillation, 426  
 —, —, saturated, 10c  
 —, —, seed fats, 8c, 9a, 17c-286, 55a  
 —, —, even - numbered, saturated, 8d  
 —, —, separation by crystallisation, 2d  
 —, —, distilling methyl ester\*, 3a, 156, 696  
 —, —, lead salts, 26, 65a  
 —, —, elaidic acid, 696  
 —, —, from insoluble bromides, 696  
 —, —, structure, 106, d  
 —, —, synthesis, 10d, 11e  
 —, —, tetraethenoid, 14d, 276, 286  
 —, —, triethenoid, 13d, 146  
 —, —, —, detn. by ultra-violet absorption, 2d, 14c  
 —, —, unsaturated, 10d  
**Fayalite**, 93a  
**"Ferroin"** indicator, 148c  
**Fick's law** and diffusion of ions, 141a\*  
**Finishing coats**, 206a  
**Fish liver oils**, 6a, *Ud*, 34a, 54a  
 — oils, sulphated, 51c  
**Fitelson test**, 72d  
**Flat finish**, 206c  
**Flaviciidin**, 2696  
**Flavin-adenine** dinucleotide, 164c  
 — dinucleotides, 164 a  
**Flavoproteins**, 163d, 164a  
 — in respiration, 164d  
**"Fixed oils"**, 1c  
**Flow sheet** (phase rule), 457d  
**Fluorapatite**, 482d  
**"Fluorite"**, 6116  
**"Foots"** from refining oils, 416, 6V42a, 57c  
**Forsterite** refractories, 93a, 6  
**Franck - Condon** Principle, 531a  
**"Freon"** S13d, 396c  
**Fruit-coat fats**, 8c  
**Fuel oil** contamination, 58a  
 — in whale oil, detn., 58a  
**"Fugitometer"**, 586c, d  
**Fuller's earth**, 6316  
**Fumigants**, 312a  
**Fumigation**, phosphine, 516d  
**Fungicides**, 400b  
**Furnace oils**, 3196
- G**
- Gadoleic acid**, 12a  
**Galloryanines**, 151c  
**Gamboge** butter, 206  
**"Gammexane"**, 311a  
**Gasification** of solid fuel, oxygen in, 181d  
**Gas oils**, 390c  
**Gasoline**, 374c  
 —, airplane, 382c, 383a, 3846  
 —, —, alkylate\*, 3836  
 —, catalytically cracked, 344d, 3776  
**Gasoline**, catalytically - re-treated, 344a  
 — from thermal cracking, 377a  
 — vapour-phase cracking, 377c  
 —, gum detn., 376a  
 —, — inhibitors, 3816  
 —, hydrocarbons, 3766, 377d  
 —, olefin removal from, 3446  
 —, polymer, 352c, 377c"  
 —, polytreating, 3446  
 —, properties, 375c  
 —, reformed, 339a  
 —, Reid test, 376a  
 — substituents, 387c  
**Geyserite**, 97d  
**Gibbs energy**, 2386  
**Ginger oleo-resin**, 906  
**"Glassine"**, 232c  
**Glyceride** separations, 70a  
 — by hydrogenation, 70c  
**Glycyphyllin**, 481c  
**Gnoscopine**, 112a  
**Gorlic acid** structure, 126, 13a  
**Gossypol**, 42d  
 —, detn., 58d  
**Graham's salt**, 510a  
**Graphite**, 640d  
 Graphitic oxides, 177c  
**Greases**, 29d, 406  
**Green acids**, 398d  
 —, Emerald, 639a  
 —, Malachite, dye, 639a  
 —, Binmann's, 639a  
 —, Scheele's, 639a  
 —, Viridian or Guignet's, 639a  
**Greens**, Brunswick, 638a  
 —, chrome, 638a  
 —, — oxide, 638a, d  
 —, copper, 639a  
 —, zinc, 638c  
**Gregory's salt**, 103a  
**Groundnut**, peanut or earthnut oil, 226, 53a, 55a  
 — oil, hydrogenated, 22d, 53c  
**Grotthus-Draper** law, 542a  
 Grinding pigments, 6256  
**GR-S**, 397c  
**Grugru** fat, 176\*  
**Gurgi** nut fat, 206  
**Gypsum**, 6306
- H**
- Halation**, 5536  
**Half-life** of molecules, 5336, 542a  
**Halphen's test**, 71c  
**Heavy spar**, 630a  
**Heliotropin**, 286c, 649c  
**Helium**, natural gas, 3726  
**Hemp-seed** oil, 26d, 276, 55c  
**n-Heptaldehyde**, 283c  
**"Heroin"**, 105d  
**Hesperidin**, 2016, d  
 y - **Hexachloroq/c/hexane**, 311a  
**Hexadecenoic acid**, 6d, 86, 10c, 37a  
 —, structure, 12a  
**Hexa-ethenoid C<sub>24</sub> acid**, 156  
**Hexahydroxybenzene**, 479a  
**Hormone**, catabolic, 660c  
 — of growth, 658d  
 — FSH, 6596  
**Hormones**, pituitary, 658c  
**Horse body fat**, 306  
**Hue** of pigments, 624c  
**Human Hair** fat, 31d
- Humboldtine**, 149a  
**Hurter** and Driffield curve, 547c, 667a  
 — gamma, 568A  
**Hydnocarpus** oil\* (see also Ghaulmoogra oil), 21a, 56c  
 — in treatment of leprosy, 12d, 216  
**Hydro-codimer**, 352a, c  
**Hydrocotarnine**, *Hid*, 114d  
**Hydrocyanic acid**, 312a  
 —\* — warning gases, 312a  
**Hydrogen** acceptor, 1606 «  
**Hydrogenation**, destructive, 363d  
 — of unsaturates, 363a  
**Hydrogen** donor, 1606  
 — halides, ultra-violet absorption spectra, 534i  
 — overpotential, 442e  
 — peroxide of crystallisation, 2956  
 — phosphide, solid, 516a  
 — production, 366a  
 — transportase, 1606  
**Hydroperoxides**, 2966  
**Hydroquinone**, 476r  
**Hydroxonium** ion, 176a  
**Hydroxy-acids** detn., 641  
**Hydroxy-alkyl** hydrogen peroxides, 296c  
**HydroxycitronelW**, 284c  
**a-Hydroxyethyl** hydrogen peroxide, 296d  
**12 - Hydroxy - X\* - octa - decenoic** (ricinoleic) acid, 13c  
**Hypophosphoric acid**, 5066  
**Hypophosphorous acid**, 507c  
**Hypophysis cerebH**, 658a
- I**
- Ulpe\*** butter, 206  
**"Indalone"**, 312c  
**Indanthrene** pigments, 646d  
**Indicators**, 4246  
 —, colour changes, 421a, 4246, 4286  
 —, comparators, 4280  
**Indole**, 28&J  
**Induction** period, 542a  
 — in fat oxidation, 486  
 — **H<sub>a</sub>+G<sub>1</sub>** reaction, 535a  
**Infrasizer**, 242d  
**Infusorial earth**, 97d  
**Inner light** filter, 5426  
**Insecticide** dispersal, 312d  
 —, naphthalene, 312c  
 —, nicotine, 305a, d  
 —, Paris Green, 304a  
**Insecticides** (see also Pest control), 4006  
 —, arsenate, 3046  
 —, arsenite, 3046  
 —, contact, 305a  
 —, copper and sulphur, 3086  
 —, ethylene oxide, 312c  
 —, fluoride, 304d  
 —, halogenated hydrocarbons, 3126  
 —, hydrocarbon, 307c  
**Insecticide** sprayers, 3136  
**Insecticides**, stomach, 304a, 305a  
 —, synthetic organic contact, 308d  
**Insect** pests control, 302d

- Insect repellents, 312c  
 Insulating oils, 4006\*  
 Iodine Value, Hanus, 60(2)  
 —, MM, 60(2)  
 —, Rosei4hund - Kuhnhenh, 60(2)  
 —, Wijs, 606  
 Ionic activity coefficient, 141a  
 — mobility and electrophoretic effect, 95a  
 — time of relaxation, 95(6)  
 Ionones, 2876  
 Iro<sup>r</sup>porphyrin, 165(2), 1666  
 — oxide pigments, 631(2)  
 £-, removal from water, 514a  
 Isohydric, 424(2)  
 Isomerisation with aluminium chloride catalyst, 361a
- J**  
 Jaggery, 212a  
 Japan wax, 166  
 Jasmone, 287d  
 Java almond fat, 166, 206
- K**  
 Kanya fat, 20b  
 Kapok oil, 24c, (2), 536, 55c  
 Kerosene, 389c  
 Keto-el8Bost89rlc acid, *see* Licanic acid  
 Ketone peroxides, 298c  
 4-Keto-J>> "u>18 - octadecatrienoic (licanic) acid, 96, 136, 14(2), 28a, 81a  
 Kieselguhr, 97d  
 Kirschner Value, 68a  
 Kleman formula, 225c  
 Knocking of gasoline, 375a  
 Knotting, 207a  
 Kohlrausch law of independent migration of ions, 140(2)  
 — square root law, 94(2)  
 Kokuzn fat, 20a  
 "Kraft" pulps, 219a  
 Kreis-Kerr test, 496  
 Kurrol salts, 5116
- L**  
 Laccase, 166c  
 Lackmoid, 150c  
 "Lacquer," 203c  
 Lactoflavin, 163(2)  
 Lakes, 623c, 6426  
 — from acid dyes, 6436, 645a  
 — anthraquinone, 6466  
 — bases, 643c  
 — basic dyes, 645(2)  
 — formula for, 645(2)  
 Lambert-Beer law, 241c, 243(2)  
 Lanolin, 316  
 Lanthopine, 104a, 115a  
 Lard, characteristics, 28c, 53c, d  
 — crystallisation, 53c, 70(2)  
 "Lard, neutral," 39(2), 406  
 "Laudanidine," 104a, 113(2)  
 Laudanine, 104a, 113c  
 Laudanosine, 103(2), 113a  
 Laurie acid in fats, 176, 18c  
 — syntheses, 10(2)  
 Laurite, 133(2)  
 "Lauseto New," 312a
- Law of mass action for activities, 140(2)  
 — rectilinear diameters, 1326  
 Lead sulphate, basic, 627a  
 Leaf pigments, 592(2)  
 Lecithin detn., 580  
 Lemon chrome, 634c  
 Levigating pigments, 6256  
 Licanic acid (*Licania rigida*), 96, 136, 14(2), 28a, 81a  
 Liebermann-Storch test, 72c  
 Light-fading prevention, 590c  
 Light-fastness and humidity, 589a  
 — hydrogen peroxide, 5896  
 — of dyes, 585(2), 587(2)  
 — sources, photochemical, 5276  
 linalyl acetate, 288c  
 Linde oxygen process, 183c, 185a  
 linoleic acid, 24a  
 — distribution, 14a  
 — reactions, 136  
 — structure, 136  
 Jinolenic acid, 26a  
 — reactions, 146  
 — structure, 136  
 Linseed oil, boiled, 266  
 — "break" test, 41a, 59a  
 — characteristics, 27a, 536, 55c, 62a  
 — components, 26a, 27a  
 — distribution, 27a  
 — polymerisation, 50c  
 Lipase, 44c, 45a, 46(2)  
 Lippmann process, 577c  
 Lithopone, 627(2)  
 Liver-fats, *Id*  
 Logwood lakes, 642c  
 Lubricating oils, 392a  
 Lumbang (candlenut) oil, 26c, 276  
 "Luminal," 466c
- M**  
 Mackey test for spontaneous heating of oils, 766  
 Macleod's rule, 225c  
 Maclurin, dyestuff, 826  
 Maddrell salt, 5096, 510(2)  
 Magnesite, 630(2)  
 Magnesium peroxide, 293a  
 Mahogany acids, 398(2)  
 Maize (corn) oil, 25c, 53a, 55a  
 Malabar tallow, 206  
 Malachite (min.), 639a  
 Male fern oleo-resin, 90c  
 Maleic Anhydride Value (M.A.V.), 61c  
 Malonate reagent in cell metabolism, 161(2)  
 Margarine, 17c, 27a, 296, 31(2), 41c  
 Mean ionic activity, 417c, 4246  
 — strength, 4246  
 Meconic acid, 99c, 1156  
 Meconidine, 115a  
 Meconine, 99c, 1126, 1156  
 Meconoisin, 1156  
 Medium (vehicle), 2036  
 Meso-compound, 117(2)  
 Meta and polyphosphates of calcium, 5926  
 Metaphosphoric acid, 506a  
 Metaphosphorous acid, 507c  
 Methaemoglobin, 166a
- Methoxyacetophenone, 286(2)  
 p - Methoxyphenylacetaldehyde, 285a  
 Methyl anthranilate, 2896  
 — benzoate, 2896  
 6-Methylcoumarin, 2906  
 Methyl heptyne carboxylate, 2896  
 — hydrogen peroxide, 2966  
 Methylionones, 287c  
 Methyl iV-methylantranilate, 289c  
 — j3-naphthyl ketone, 287(2)  
 Methyl - n - nonylacetaldehyde, 2846  
 Methyl salicylate, 288c  
 — n-amyl ketone, 286c  
 Mitscherlich pulp, 219(2)  
 Molozonides, 198c  
 Molybdic acid catalyst, hydrocracking, 364a  
 Monochromator, 5426  
 Monosodium phosphate, 495(2)  
 Montmorillonite, 369(2)  
 Morin, synthesis, 81(2)  
 Morphine, assay in opium, 104a  
 — constitution, 106c  
 — diacetyl (diamorphine), 105(2)  
 — in opium, 996, c, 1006, 1016, (2), 102c, 103a, d, 104a, 105a, 6  
 — properties, 1056  
 apoMorphine, 106a  
 pseudoMorphine, 103(2), 109(2)  
 Morse equation, 5426  
 Motor fuel, 374a  
 Mowrah fat, 206  
 MuPumuru fat, 176, 18c  
 1-Muscone, 291a  
 Musks, artificial, 289(2)  
 Mustard oils, 23a  
 Mutton tallow, component acids, 7a, 286, 30a  
 Myristic acid, distribution, 9a, 10c, 18c  
 Myristoleic acid, 12a
- N**  
 Naphthenes, 3206  
 Naphthenic acids, 327a, 400a  
 nS-Naphthol, ethers of, 2836  
 Naphthophenoxazine dyestuffs, 150(2)  
 Narceine, 103a, 113(2)  
 — reactions, 114a  
 Narcotine<sup>^</sup> 996, 103a, 6, d, 1056, 111c  
 Narcotine, 113a  
 Natural fatty acids, *see* Fatty acids  
 Neats<sup>1</sup> foot (trotter) oil, 31a  
 "Nembutal," 276a  
 Neopine, 109(2)  
 "Neoprene" rubber, 397c  
 {fernst equation of electrode potential, 141c  
 Netol, 281(2)  
 Nerolidol, 2826  
 Nervonic acid in brain cerebroside, 12a  
 Neuberg chalk, 6816  
 Neutralisation of acids and bases, 424(2), 425c  
 Nickel, (fctn. in oils, 54(2), 596)  
 — oxide, NiO, composition, 177a  
 Nicol prism, 116(2)

- Nicotinamide, 165c  
 Niger-seed oil, 25b, d  
 Nitro-paraffins, 390d  
 n-Nonaldenide, 283d  
 n-Nonyl alcohol, 281c  
 Nutmeg fat, 19a  
 Nut oil, alcohols and detergents from, 17c
- Octadecadienoic acid (animal), 76  
 cis -cisA<sup>9,11</sup>- Octadecadienoic (linoleic) acid (seed fats), 136  
 Octadecadienoic acids, isomers, 136, 14a  
 £», n, is - Octadecatrienoic, (elsoBtearic) acid isomers, 136, 276  
 j», is, is - Octadecatrienoic (linolenic) acid isomers, 136, 26a  
 cis - J" - Octadecenoic (oleic) acid, 10b, 11a, 21d  
 Octadecenoic acid, structure, 11a, 12a, 6  
 n-Octaldehyde, 283c  
 Octane numbers, A.S.T.M., 3756, 379a  
 IsoOctanes from butanes, 352c  
 Octylphenols, 4746  
 Odoriphorea, 135 d  
 CEnanthol, 283c  
 Oil absorption, 203a  
 Oil-emulsion finish, 206d a  
 Oil refining, alkaline, 416, 369a  
 Oils, see also Fat analyses; Fats; Fatty acids  
 —, by-product, analysis, 566  
 —, "drying" (see also Fats, unsaturated), 26a  
 —, —, cyclic polymers, 50a  
 —, —, effect of heating (see also Fats^ unsaturated), 49a", 50c  
 —, —, "hydrogenation - cracking," 50a  
 —, —, "non-drying" and "semi-drying," 24a  
 —, —, oxidation, 47a, 40a"  
 —, —, thermal polymerisation, 50a\*  
 — (fatty) and fata, la  
 —, —, technical analysis, 52c  
 —, fish, analyses, baskingsbark, coalfish, cod, dogfish, hake, halibut, herring, ling, pilchard, sardine, salmon, 34a  
 —, —, and marine animal, analyses, 7a, 34a, 37a, 53c, 54a  
 —, fish body, hydrogenated, 15c  
 —, —, glycerides, 36a  
 —, —, liver, 66, 34a, 54o  
 —, hardened, detection, Sid, 596  
 —, pairft industry, 56a  
 —, spontaneous heating, see Mackey test  
 —, stand, 26t; 506  
 —, sulphated (suiphonated), 516  
 —, sulphur, 566, 58c
- Oils, vegetable, analyses of arabis, castor, cotton, hemp, kapok, Unseed, 55a, c  
 —, —, —, bydnocarpuB, sunflower, teaseed, tung, 56a  
 —, —, —, \*maize, oiticica, olive, perilla, poppy, rape, sesame, soya, 55c  
 —, —, —, vulcanised, 52a  
 Oilseed cakes, 39a  
 —, —, toxic, 396  
 Oiticica oil, 144, 28a, 636, 55a, 80f  
 Okra fruit, Gumbaut, Gumb< % 81a  
 Old fustic, dyewood, 81c  
 Olefin hydrocarbons, 3206  
 Olefins, 82c  
 —, additive reactions, 86a  
 — and polymerisation catalysts, 85d  
 — as alkylating agents, 87c  
 — from "cracking," 83d!  
 —, isomerisation, 82c, 846  
 —, ozonides, 88a  
 —, polymerisation of high- on low-molecular, 85a  
 —, 9 preparative methods, 82ti  
 —, production, 3306  
 —, potato - growth stimulants, 400a"  
 —, substitution in, 88i  
 Oleic acid, 106, 11a, 21a"  
 —, reactions, 116  
 —, stereoisomers, 116  
 —, synthesis, lie  
 Oleines (oleins), 53c, d, 54a  
 Oleoeuropein, 91a  
 Oleo oil; oleo stearin, 40c  
 Oleo-resins, 89c  
 Oligoclase, 90c  
 Olive (*Olea europcea*), 90c  
 — oil, 91a  
 —, adulteration, 64a, 926  
 —, characteristics, 22a, 536, 55a, 91d  
 —, extraction, 37a\*, 916  
 —, unsaponifiable portion, 22a, 926  
 —, uses, 216, d, 926  
 Olivenite, 92c  
 Oliver's bark, 92a"  
 Olives, vitamin-^, 91a  
 Olivetoric acid, 02d  
 Olivine, 93a  
 Ongokea diacetylenic acid, 136  
 Onion (*Allium cepa*), 93c  
 —, vitamins, 046  
 Onofrite, 94c  
 Ononin, 946  
 Ononis root, 946  
*Onosma echioides*, 94c  
 Onsager equation for strong electrolytes, 94c, 140a"  
 Onyx, 976  
 Oolite, 976  
 Opal, 97c  
 Opianio acids, 98a, 1126  
 Opiaurin, 986  
 Opium, 986  
 —alkaloids, manufacture, 102a, d  
 — components, 99c  
 — legislation, 105a  
 —, minor alkaloids, extraction, 103c  
 —, physiological action, 1206  
 — production, 100a  
 Opium-smoking, 99a, 102c  
 Optical activity, 116a
- Optical activity and circular dichroism, 1W6  
 —molecular structure, Uib  
 —in pnotoct^oiiical syntheses, 1186  
 —s, molecular theories, 118c  
 —of inorganic moletules 118a  
 —cycZoparaffinfl, 118a  
 — isomers, resolution, 116a, U86  
 — rotatory power, 116o  
 Orange, 119c  
 — Chromes, 634c  
 — flowers, leaves, oils of, 120d\*  
 — Lead, 630i  
 —, "navel," 119c \*  
 —, Palatine, 120a" t  
 — pectin, 1206  
 — peel pigments, 1206  
 —, ripening changes, 1206  
 —, — with ethylene, 1206  
 —, Salicylic, 120J  
 —, vitamin-6<sup>1</sup>, 120c  
 Orangifcj, 120f  
 Ornitals, electronic, 120ti  
 Orcein, 120<i  
 Orchil, 121a ft  
 Orcin, 121a  
 Orcinol, 121a  
 Ordeal bean, 121s  
 Order of bonds, 1296  
 Orientation at surfaces, 1296  
 Origanene, 120b "  
 Origanum oils, 1296  
 Ormosine, ormosinine, 1296  
 Ornithiae, 1296  
 —, detn., 130a  
 —, identification, 1306  
 —> isotopically labelled, 130a  
 /-Ornithine, metabclism, 129d  
 (t/-Ornithine, synthasis, 130c  
 Ornithuric acid, 1296, 1306, 131a  
 Orpiment, 131a  
 Orris root, 1316  
 Orsellinic acid, 1316  
 Orthite, 1316  
 Orthobaric density, 131c  
 "Orthocaine," 1326  
 Orthoclase, 1326  
 Orthoderie, V&2d  
 "Orthoform, Neiv," see Orthocaine  
 Orthohydrogen, 132rf  
 Oryzanin, 153<<  
 Osage orange tree, 133a  
 Osajin, isoOsajin, 133a  
 Osazones, 133c  
 Oscillator, energy, 133c  
 Osmate, potassium nitrosochlor-, 135a  
 Osmiamic acid, 1356  
 Osmic acid, chloro, salts, 134a, d, 135a  
 Osmiridium, 133c  
 Osmium, 133d  
 — carbonyls, 135c  
 — chlorides, 135a  
 —, detection, 135c  
 — dioxide, 134c  
 — fluorides, 134a"  
 — nitrite, 1356  
 — tetroxide, 134c  
 Osraocyanides, 135c  
 Osraometers, 138c 139c  
 —, diffusion of polymers in, 139a", 140a  
 —, membranes for, L39o

- Osmophorite**, 185d  
**Osmotic pressure**, 135(2)  
 — a&dtmolecular weight, 136(2)  
 — Vyi't Hbff equation, Id7#  
 — vapour pressure, 137(2)  
 — «- , definition, 136a  
 —, interpretation, 140a  
 — of high polymers, 137a, 138c  
 —, origin, 136a  
**Osones**, 140c\*  
**Oswald dilution law**, 140c  
**Otavite**, 1416  
**Ouabagenin, ouabain, ouabain tree**, 1416  
**Overpotential**, 1416  
 — and catalytic poisons, 1446  
 — temperature, 144a  
 —, growth and decay, 7446  
 — of deuterium, 144(2)  
**Overvoltage**, 141c  
**Oxalates**, 148(2)  
**Oxalic acid**, 147c  
 —, detection, 1474  
 —, detn., 1486  
 —, — in urine, 148c  
 —\* from moulds, 1476  
 —, photo - decomposition, 147e  
**NiN'-Oxalyl ure&**, 225a  
**Oxazine dyestuffs**, 1496  
 "Oxford unit," 271(2)  
**Oxidase**, aMufe, 167a  
 —, —, inhibition, 1676  
 —, ascorbic acid, 166(2)  
 —, cytochrome, 166a  
 —, diamine, 1676  
 —, polyphenol, 166c  
**Oxidases**, 164a  
 —, aerobic, 160a, 1656  
 —, amind-acid, 165a  
 —, anaerobic, 160a  
**Oxidation, direct**, 176a  
 —, hydrocarbon, 178a  
**Oxidation-reduction potentials**, 154a  
**Oxide pigments, British Stand.\*** 6346  
**Oxides {see also Peroxides}**, 1760  
 —, graphitic, 177c  
 —, metallic, 177(2)  
 —, non-stoicheiometric, 1776  
**Oxonium salts**, 176a  
**Oxozonides**, 201c  
**Ox, pig and sheep depot fats**, 306  
 44 **Oxsorbent " reagent**, 179a  
**Oxyacanthine**, 167(2)  
**Oxy-acetylene descaling**, 180c  
 — surface hardening, 180(2)  
**Oxycoccicyanin**, 168a  
**Oxygen**, 168c  
 —, applications, 180c  
 —, atomic, preparation, 1746  
 —, —, reactions, 174(2)  
 — basis for atomic weights, 172c  
 — bonds, 175(2)  
 —, Claude process, 1846  
 —, colloidal, 172c  
 — crystal structures, 1726\*  
 —, desurfacing process with, 180(2)  
 —\*, detection and detn., 1786  
 —, — of traces, 179c  
 —, detn., automatic, 179(2)  
 —, —, continuous absorption, 178(2)  
**Oxygen**, detn., in compounds, 180a  
 —, —, water, 1786  
 —, electrolyzers for, 191a  
 —, electrolytic, 1706, 189(2)  
 — for iron cutting, 186a  
 —, Frankl regenerator, 188(2)  
 — from electrolysis of barium h^roxide, 1706  
 — W Air Liquide process; 187a  
 — liquid air, 183a  
 — peroxides, 169a"  
 — potassium chlorate, 1696  
 —, Heylandt process, 185c  
 —, high-pressure electrolysis, 191(2)  
 —, history and occurrence, 168cId  
 —, industrial, 186c  
 — ions, 176a  
 — isotopes, 172d  
 —, detn., 173c  
 —, exchange reactions, 173c,V2  
 —, ^radioactive, 175c  
 —, separation, 173  
 —, Linde double column process, 185a  
 —, Linde's process, 183c  
 —, liquid, 171c  
 —, litre weight, 170e  
 —, meter, magnetic, 179(2)  
 —, molecule, 1706  
 —, overpotential, 145c  
 —, physical properties, 1706  
 —, plants for liquid, 186(2)  
 —, preparation, 169a  
 —, —, accidents, 169c  
 —, production, 1826  
 —, purity, 186a  
 —, solid, 1726  
 —, solubility, 171a  
 —, spectrum, 170(2)  
 —, storage and transportation, 187d  
 —, tetra-atomic, 1756  
 —, ultra-violet absorption, 533a  
**OxyhaBmoglobin**, 191(2)  
 "Oxyliquid," 191(2)  
**Oxynarcotine**, 1136, 191(2)  
**Oxyphloroglucinol**, 191(2)  
**Ozokerite**, 191(2)  
**Ozone**, 192a  
 — and halogens, 196a  
 — organic compounds, 196(2)  
 —, atmospheric, 1926  
 — attack on rubber and grease, 197a  
 —, detection and detn., 197a  
 —, bleaching, 197a  
 —, b.p. and critical properties, 195c  
 —, chemical properties, 195c  
 —, chemiluminescence, 197a  
 — from chemical reactions, 193c  
 — electrolysis, 1936  
 — formed in ultra-violet light, 1926, 193a  
 — formulation difficulties, 1946  
 —, liquid, 195(2)  
 —, optical properties, 1956  
 —, physical properties, 1946  
 — preparation, 1926  
 —, pure, 193(2)  
 —, reaction with elements, 195(2)  
 —, sterilisation of water, 197a  
 —, thermal formation, 192c  
**Ozonides**, 197(2), 199a, 200a  
 iso-Ozonides, 198c  
**Ozonidea and peroxides**, 199a  
 —, decomposition, 198a  
 —, dimeric, 200(2)  
 —, inorganic, 197(2)  
 —, monomeric, decomposition, 2006  
 —, polymeric, 201a  
**Ozonisers, industrial**, 193(2)  
 —, low temperature, 193a  
**Ozonolysis**, 197(2)  
 — of triple bonds, 200a
- P**
- Paint, covering power**, 625a  
 — oils, 56a, 202c  
 — spreading rate, 625a  
**Paints, 202e**  
 —, antifouling, 2076  
 —, boot-topping, 207cj  
 —, brushed, dipped or sprayed, 207(2)  
 —, decorative protective, 207a  
 —, zinc oxide, 206c  
**Palladic chloride**, 210(2)  
**Palladium**, 208(2)  
 — alloys, 210a  
 — amines, 211c  
 —, detection, 211(2)  
 —, dichlorodiammino-, 209a  
 —, hydrogen absorption by, 209(2)  
 — catalyst or filter, 210(2)  
 — oxides, 2106  
 —, properties, 2096  
 —, pure, 209a  
 —, separation, 2116, d  
 —, uses, 2106  
**Palladonitrites for electroplating**, 211(2)  
**Palladium chloride**, 210(2)  
 — cyanide\*, 2116  
 — sulphate, 2116  
 — sulphide, 211a  
**Palmes, seed fats, babassu, cohune, grugru, murumuru, ouricoury, tucuma**, 176  
**Palmitic acid, occurrence**, 106, 196  
**Palmitoleic acid {see also Hexadecenoic acid}**, 10c, 12a  
**Palm-kernel oil**, 16ft, 176, 186, 53c, 54c  
 —, crude, 54c  
 —, extraction, 38a  
 —, olein, refined, 54c  
 —, stearin, refined, 54c  
**Palm oil**, 166, 186, 54c, 211(2)  
 —, extraction, 37(2)  
 —, refined, 54c  
 —, substitutes, 170  
 — sugar, 211(2)  
**Paludrine**, 2126  
**Pamaquin**, 3126  
**Panchromatic plates**, 576(2)  
**Pan mill**, 205a  
 "Pantocaine," 2126  
**Pantoic lactone**, 213a  
**Pantothenic acid**, 212c  
 — as vitamin, 214c, 215a  
 — derivatives, 2156  
 —, detn., 213a  
 —, isolation, 212(2) «  
 —, pharmacology, 215a  
 —, physiological activity, 213(2)  
 —, stereochemistry, 213(2)  
 —, synthesis, 213c  
**Pantoyltaurin**, 215c

- Papain, 215c  
 Papaveramine, 115a  
 Papaveretuxn, 102c  
 Papaverine, 1036,(2),1056,1106  
 —, synthesis, 1116  
 "pseudoPapaverine," 112(2)  
*Papaver somniferum* var. *album*,  
 and var. *glabrum*, 986  
 Paper from pulp, 219f\*  
 — humidifier, 224a  
 —, moisture in, 223d  
 — sizing, 224c  
 Papermaking, 215(2)  
 —, duplex and triplex, 2236  
 — vat, 223a  
 Papyrus, 231c  
 Parabanic acid, 225a  
 Parachor, 225c  
 —, additive properties, 226a  
 —, —, exceptions, 227a, 230a  
 — and semi-polar double bonds,  
 227(2)\*  
 — structure, 229a  
 —, effect of bonds on, 227a\*  
 Paradol, 230a  
 Paraffin hydrocarbons, 319(2)  
 — oil, 389c  
 Paraffins, dehydrogenation,  
 353c  
 isoParaffins, 357a  
 Paraffin wax, 3926, 403(2)  
 — coated paper, 414(2)  
 — group, 404a, d  
 — waxes, finishing, 406c  
 — wax, pressing and sweating,  
 405a  
 —, solvent deoiling, 406a  
 —, utilisation, 413c  
 Paraguay tea, 2306  
 Paraxnagnetism, 230(2)  
 "ParamoU" 230(2)  
 "Paramorfan," 1066  
 Paraffin, 231a-  
 Parchment, 2316  
 — paper, 231(2)  
 Parinaric acid, 136, 14(7), 276,  
 286  
 "Parkerising," 2319a  
 Parmone, 233a  
 Parsley, 273a \*  
 —, essential oil, 2336  
 —, fatty oil, 233c  
 —, oleo-resin, 90c  
 Parsnip, 2146  
 Partial molar free energy,  
 237(2)  
 — properties of electrolytic  
 solutes, 237a  
 — quantities, 234c  
 — specific heats, 2376  
 — volumes, 235(2)  
 — of electrolytes, 235(2)  
 Particle size, 625a  
 —, average, 243  
 — by adsorption methods,  
 243a  
 — centrifugal sedimenta-  
 tion, 240c  
 — cumulative sedimenta-  
 tion, 240a  
 — elutriation, 242c  
 — 3— hydrometer, 240(2)  
 — incremental sedimen-  
 tation, 240a  
 — light - extinction sedi-  
 mentation method, 2416  
 — manometric method,  
 241a  
 — pendulum method,  
 2416  
 Particle size, by permeability  
 methods, 2436  
 — pipette, 2406  
 — sedimentation, 2436  
 — balance, 241a  
 — turbidimetric method,  
 243c  
 — distribution, 239a  
 — in the sub-sieve, range,  
 2436  
 — of cement, 240(2) 242c,  
 243c  
 Partition function, 244c  
 Passivation, mechanism, 249c  
 Passive metals and films, 248(2)  
 — non-ferrous metals, 2486  
 Passivity, 247c  
 — and water-treatment, 251c  
 — in electroplating, 2f 26  
 — protective coating, 252a  
 —, periodic, and pulse trans-  
 mission, 250(2)  
 Patchouli alcohol, 252c  
 Patina, 252(2)  
 Patronite, 252(2)  
 Patulin, 252(2)  
 — against common cold, 254a  
 Pauli Exclusion Principle, 2546,  
 542c  
 Paw-paw, *papaya* (see also  
 Custard-apple), 2546  
 Peach, *Prunus persica*, 2556  
 Pea growth, effect of Zn or Ni,  
 2566  
 —, *Pisum sativum*, *P. arvense*,  
 254c  
 Pearl, 256c  
 Pear, *Pyrus commutis*, 256a  
 Pea, vitamin content, 2556  
 Pectic acid, structure, 257c  
 Pectin, 256c  
 — araban, 256(2), 258a  
 "Pectinase," 257a  
 Pectin as source material, 258c  
 — galactan, 256(2), 258a  
 —, mol. wt., 2586  
 —, preparation, 2586  
 Pectinase, 258c  
 Pelargonin, 258(2)  
 Pelargonidin, 259a  
 — base, 260a  
 —, sources, 259a  
 Pelargonin, 260a  
 Pelletierine, 260(2)  
 Peltogynidin, 261c  
 Peltogynol, 262a  
 Penicillin, 262(2)  
 "Penicillinase," 264(2), 269a  
 Penicillin, assay, 271(2)  
 —, —, chemical, 273a  
 —, —, cylinder plate method,  
 272a  
 —, —, paper strip, 273(2)  
 —, crystallised, 267(2)  
 — dihydro F, 2696  
 —, dosage, 274(2)  
 —, extraction, 266(2)  
 —, freeze-drying, 267c  
 — G, 2696, 271d, 274c  
 \*K-1 or F, 2696  
 —, international unit, 272a  
 — K, 2696  
 —, properties, 268a  
 — references@ 268a  
 — Regulations, 275c  
 —, relative activity against  
 organisms, 274\$  
 Penicillins, differential assays,  
 273c  
 —, six 2696  
 Penicillin stability, 2686  
 — and pH, 268d  
 —, structure, 270a  
 —, synthesis, 2716  
 —, veterinary use, \*756  
 — III or X, 2696  
 Penicillium fermentations,  
 263Z  
*Penicillium notatum* - *chryso-*  
*genum*, 263(2)  
 Penicillium nutrient media,  
 2646  
 —, submerged culture, 265(2)\*  
 — surface culture, 264(2)  
 Penicilloic acid, 2706  
 Penillic acids, 271a  
 Pentamidine, 275(2)  
 cyc/oPentenyl ring in fats,\* 12(2)  
 Pentlandite, 276d  
 Pentobarbital, 27ba  
 Pentobarbitone soluble, 276a  
 "PentothaV" 276fr  
 Peonidin, 276a  
 Peonin, 276c  
 —, synthesis, 277a  
 Pepper, adulterations, 279c  
 —, black and white, 2776  
 —, long, 2806  
 Peppermint, oils, 280(2)  
 Pepper, *Piper nigrum*, 2776  
 Pepsin, 280(2)  
 Pepsinogen, 280(2)  
 "PerabrodiU" 281a  
 Peracids, 299(2)  
 Perborates, 205%  
 "Percaine," 2816  
 Percarbonates, 2946  
 Perchromates, blue and red,  
 273(2)  
 Per-compounds, 291(2)  
 Perezone, 2816  
 Perfumes, synthetic, 281c  
 "fiergamyn," 232c  
 Peridot, 936, 2916  
 Perillaldehyde, 291c  
 Perilla oil, 26c, 536, 556, 2916  
 Perillyl alcohol, 291c  
 Peritectic reaction, 291c  
 Permeability, Kozeny equa-  
 tion, 2436  
 Permolybdates, 294a  
 Permonophosphoric acid,  
 295a  
 "Pernocton," 291c  
 "Peronine," 100d  
 Peroxidase, 166a  
 Peroxides, alkali metal, 291(2)  
 —, alkaline earth, 292c  
 — and peracids, inorganic, 291(2)  
 —, organic, 295c  
 —, formula, 177a  
 — of cyclic ketones, 298a  
 —, organic, analysis, 295c  
 —, —, transannular, 295(2)  
 —, polymeric, 299a  
 Peroxide value of fats, 49a  
 Persian berries, 3006  
 Persimmon, 3016  
 Persulphates, 2946  
 Peruranates, 2946  
 Peruvial, 301(2)  
 Pervitin, 301(2)  
 Pest control, 301(2)  
 —, biological, 302(2)  
 —, chemical, 303(2)  
 —, mechanical, 3036  
 Pests of stored food, 302a  
 —, rodent, 314a  
 Petalite, 314(2)  
 Pethidine hydrochloride, 314(2)

- Petrol, *see* Gasoline  
 Petrolatum, 3946  
 Petrolatum waxes, 4046, 406d  
 Petroléuili, 3150  
 — aromatic 321a  
 —, ash content, 324a  
 —, ceresins, 4046, 406(2)  
 —, Chemical products, 396a, 398a, 399a  
 —, composition, 3186  
 —, cracking, 325a, 3306  
 —, Dubbs (ffoegs), 332d  
 —, *T*- for gasoline, 336a, 337a  
 —, crude, 329a  
 —, "flash topping," 3276  
 —, fractionation, 321a  
 —, fuel oils, 393a  
 —, *games*, 370c  
 —, literature, 401  
 —, nickel content, 324c  
 —, nitrogen compounds, 3226  
 —, origin, 315f  
 —, oxygen compounds, 322d  
 —, production, 317a  
 —, products, 3706  
 —, refining, 324(2), 325\*  
 Petroleum, medicinal, 397d  
 Petroleum stabiliser, 3284, 330d  
 —, stills, 325c  
 —, flash chamfr, 3356  
 —, sulphur compounds, 322a  
 —, tests, 400a\*  
 —, thermal cracking, 330d  
 —, treating, 320a  
 —, vanadium content, 3246  
 —, vapour-phase cracking, 3386  
 —, viscosity breaking, 3376  
 —, waxes, 3926, 403d  
 —, composition, 407c  
 —, halogenation, 4136  
 —, oxidation, 413a  
 —, properties, 4096  
 —, refractive indices, 410a  
 —, solubility, 4106  
 —, tests, 407a  
 Petroselinic acid, distribution, 13a, 233d  
 Petunidin, 416a  
 Petunin, 416d  
 Petzite, 417c  
 pH and activity theory, 419a  
 —, precipitation, 427a  
 —, standard cells, 417Z  
 —, controllers, 437a  
 —, detn., colorimetric, 4286  
 —, electrodes, 430a  
 —, electrometric, 429c  
 —, potentiometric, 434a  
 —, recorders, 434d  
 —, during neutralisation, 4216  
 —, of carbonates and phosphates, 428a  
 —, sulphides, 427a\*  
 —, replaced by mean ionic activities, 4170  
 —, scale, 419c  
 —, values, 417c  
 Pharbitidin, 438c  
 Phase-boundary potential, 438c  
 Phase equilibrium diagrams, 4396  
 —, rule, 438c  
 —, and temperature, 445c  
 —, and composition, 440b  
 Phelland: 459a  
 a-Phellandrenol, 4596  
 a-Phellandrene, 4596  
 Phellandrene, 459c  
 Phenacetin, 459c  
 Phenacite, 459c  
 Phenanthraquinone, 4656  
 Phenanthrene, 459c  
 —, and derivatives, prepn., 460c  
 —, carboxylic acids, 465a  
 —, reactions, 461d  
 —, sulphonation, 463a  
 Phenanthrols, 464c  
 Phenanthrylamines, 4616  
 Phenazone, 466c  
 —, "Phenobarbitone," 466c  
 —, "soluble," 466d  
 Phenocyanine VS, 151d  
 Phenol and homologues, 466d  
 — (Carbolic Acid), natural, 470a  
 Phenols, dihydric, 475c  
 —, monohydric, 469a  
 —, —, characterisation, 469c  
 —, —, sources, 470a  
 —, number of isomeric, 466d  
 —, properties, 467a  
 —, trihydric, 4776  
 Phenol, synthetic, 470c  
 —, *p*-ter\*-butyl-, 473d  
 —, *p*\*-butyl- (tetramethylbutyl-), 4746  
 —, uses, 471c  
 Phenothiazine, 479a  
 Phenylacetaldehyde, 284d  
 Phenylacetic acid, 4796  
*D*-Phenylalanine, 480c  
*Z*-Phenylalanine, 479d  
*n*-Phenylethyl alcohol, 282c  
 Phenylethyleneglycol, 283a  
 Phenylcopropylamine, 162a  
 Phloretin, 481c  
 Phloridzin, 481c, d, 4826  
 Phloroglucinol, 478c  
 PhcBnicein, 4826  
 PhoBnin, 4826  
 Pholedrine, 482c  
 Phosphate rock, phosphorite, 482c  
 Phosphates, meta- and poly-, 513a  
 Phosphatides, 1a  
 Phosphides, metallic, 516a  
 Phosphine and flares, 514c  
 Phosphines, mono-, secondary, and tertiary, 523c  
 Phosphine toxicity, 515a  
 Phosphonium compounds, 515a, 524d, 525d  
 Phosphoric acid, 491c, 503a  
 —, purification, 4956  
 —, acids, sodium salts, 508c  
 —, acid, uses, 496c  
 —, 1 vet-process, 492d  
 Phosphorous acid, 506d  
 Phosphorus allotropes, 4830  
 —, blast furnace, 487d  
 —, cyanides, 522a  
 —, cyclic compounds, 5246  
 —, electrothermal production, 488a  
 —, elemental, 483c  
 —, furnace-slag, 491a  
 —, halides, 517a  
 —, organic derivatives, 523c  
 —, oxy- and thio-halides, 519c  
 —, oxychloride, 520a  
 —, pentachloride, 518c  
 —, pentasulphide, 5256  
 —, pentoxide, 499d  
 —, peracids, 5086  
 —, radioactive? 4860  
 —, red, 496d, 497d  
 —, stereochemistry, 525c  
 —, sulphides, 522c  
 Phosphorus sulphochloride, 521a  
 —, synopsis, 482a  
 —, tetroxide, 502a  
 —, toxic properties, 4996  
 —, trichloride, 5186  
 —, trioxide, 501c  
 —, vapour, 484d  
 —, thermodynamics, 485a  
 —, white, 485d  
 —, —, production, 486c  
 Photochemical Equivalence Law, 542c  
 —, halogenisation, 5366  
 —, light sources, 5276, 5286  
 —, threshold, 542c  
 Photochemistry, 526a  
 —, of aldehydes, 537c  
 —, ammonia, 538d  
 —, double bonds, 539c  
 —, dyes, 5416  
 —, hydrocarbons, 5376  
 —, ketones, 5386  
 —, nitrogen dioxide, 539a  
 Photo-dichroism, 5436  
 Photo-dye copying, 574c  
 Photographic chromaticity, 578b  
 —, colour recording, 575c  
 —, developers, 560a, 5636  
 —, development, 555c, 559d, 660d, 569a  
 —, dye-sensitisation, 576a  
 —, emulsion, 545c, 5466  
 —, emulsion coating, 551d  
 —, fine-grain, 5636  
 —, grain-size, 547a  
 —, hardening, 5510  
 —, manufacture, 548a, 549a  
 —, *O*- speed, 547c, 567a  
 —, supports, 554a  
 —, taothiocyanate sensitisers, 549d  
 —, fixing, 563d  
 —, latent image, 655d, 5576  
 —, history, 654c  
 —, plan-copying, 5746  
 —, positives, 569a, 570d  
 —, toned, 565c  
 —, printing paper, 55Qc  
 —, raw materials, 551a  
 —, reversal, 5630  
 —, sensitometry, 566a, 569d  
 —, washing, 565a  
 Photography, 543c  
 —, colour, coupling in tripack, 581d  
 —, dye-bleaching colour, 584c  
 —, infra-red, 577a  
 —, mosaic screen, 580c  
 —, *Photo*\*-ure, 673c  
 Photoethography, 5726  
 Photo-mechanical processes, 571d  
 Photo-oxidation, 539d  
 —, of ary\* hydrocarbons, 541a  
 —, ethylenic compounds, 540c  
 —, rubrene, 540d  
 Photosensitisation, 535c, 541d, 542d, 584d  
 Photosensitivity of dyestuff, 584d  
 Photo-stationary state, 582d  
 Photosynthesis in plants, 5926  
 —, solar energy used, 594a  
 Photosynthetic formaldehyde assumed, 596a



- Phototropy, 6436, 685a  
 Phthalate buffer and standard, 600c  
 Phthalates, 6006  
 Phthalic acid, 597c  
 — and anhydride, chemical properties, 5996  
 —, detn., 6026  
 —, dibutyl ester, 6102, 612a  
 —, dimethyl ester, 611c  
 —, esters, acid and neutral, 610c  
 —, uses, 611a  
 —, manufacture, 603c, *d*  
 —, catalysts, 6046  
 —, process and plant, 6056  
 —, reactions in, 6042  
 —, properties, 598a  
 —, reactions, 6082  
 Phthalic acid, 697(2), 6166  
 Phthalic acids, halogenated, 613d  
 —, nitro-, 614c  
 —, nuclear halogeno-, 613c  
 —, sulpho-, 614d  
 — anhydride and amines, 610a  
 — Grignard reagents, 609c  
 — phenolphthalein, 609c  
 — in alkyd or glyptal resins, 609c  
 — resins, 609c  
 —, properties, 597(2)  
 Phthalimide, 615a  
 Phthalocyanine catalysts, 620c  
 —, structure, 619c  
 Phthalocyanines, 617c, 6186, 647a  
 —, properties and uses, 319a  
 —, substituted, 618c  
 "Phthalone reaction," 610a  
 Phthalonitrile, 6152  
 Phthalyl chloride, 613a  
 "Physeteridse" oils, 6c  
*Picramnia spp.*, tariric acid, 96, 13a  
 Picrocellin, 6206  
 Picrotin, picrotoxinin, 6202  
 Picrotoxin derivatives, 622a  
 Pig body fat (lard), 7a, 28c, 30c, 53c, *d*  
 Pigment chemical iron oxide, 6336  
 — dyestuffs, 644a, *e*  
 —, oil absorption, 624(2)  
 —, opacity, 624(2)  
 —, staining power, 625a  
 Pigments, 202(2)  
 — and lakes, 6236  
 —, luminous, 641(2)  
 —, precipitated, 625(2)  
 Pimento, 6476  
 Pinacol-pinacolone transfor-  
 mation, 648a  
 Pinastric acid, 648a  
 Pinchbeck, 648a  
 Pineapple, 6486  
 Pinenes, *a*- and *p*-, 648a  
 Pinocampheol, 648(2)  
 Pinocampnone, 649a  
 Pinocarveol, 649a  
 Pinocarvone, 649b  
 Pinodry, pures, 649b  
 Piperidine, 2796  
 Piperins, 278(2)  
 Piperitone, 6496  
 Piperitone, 649c  
 Piperonal, 649c  
 Piqui-a fat, 166, 196  
 Piqui oil, 650c  
 Pisolites, 976  
 Pitch, 650c  
 — and tar, definitions, 8516, *c*  
 —, brewer's or rosin, 655a, 656c  
 —, hard, 6516  
 —, methods of test, 6526  
 —, no latent heat of fusion, 652a  
 —, soft, 6516  
 —, viscosity, 651(2)  
 Pitchblende, 6576  
 Pitch-coke, 6532  
 Pitches, less common, 655a  
 —, wood-tar, 6566  
 Pituitary gonadotropins, 659a  
 — body, 658a  
 Planck's constant, 5266  
 Plum oil, *see* Oil, almond  
 Poising action, redox, 157(2)  
 Polarimeter, 117a  
 Polarised light, 116a  
 Polenske apparatus, 67a  
 — Value, 31c, 68a  
 Polymerisation catalysts, 1786  
 — of olefins, 348c  
 —, catalytic, 349a  
 —, thermal, 348d  
 Pomiferin, 133a  
 Poppy-seed oil, 256, (2, 55c  
 "Porphyroxine," 110a  
 Potassium • palladocyanide, 211c  
 Premier jus, 296, 392, 632  
 Primer, paint, 205c  
 Primrose chrome, 634(2)  
 Prolactin, 659c  
 "Prominal," 459c  
 Propene, propylene, products  
 — solvent, liquid, 394a  
*p* - isopropylacetophenone, 287a  
 IsoPropyl ether, 3976  
 Protopine, 104a, 114(2)  
 Prussic acid, 312a  
 Purple oxides of iron, 6336  
 Putty, 207a  
 "Pyrene," 396c  
 Pyrethrum, 306a  
 —, assay methods, 306c  
 Pyrocatechol, 4756  
 Pyrogaol, 478a, 5606  
 Pyrophosphate ester of  
 aneurin, 165c  
 Pyrophosphoric acid, 505c  
 Pyrophosphorous acid, 5076
- Q
- Quantum efficiencies, 529c, 642c  
 — theory, 526a  
 Quercetin, 300c  
 Quercitol, 479a  
 Quercitins derivatives, 290a
- R
- Racemate mixture, 117(2)  
 Radiant energy units, 526a  
 Radium, *dita*  
 Rag pulp, 216(2)  
 Rancidity, detn. of peroxide-  
 oxygen in, 7Ca  
 —, hydrolytic, 44(2)  
 —, ketone, 49c, 756  
 —, oxidative, 386, 47a, 48a  
 Rancidity, oxidative, detection,  
 detn. 49a, 75c  
 Rape oil, 23a, 536, 55.  
 Rayleigh law, 243(2)  
 Red Chromes, 635a  
 — Lead, 636c  
 Redox and Van 't Hoff iso-  
 therm, 155c  
 — free energy, 155a  
 — indicators, 159c  
 —, Luther's rule in, 158(2)  
 — oxidator pr. ess., 155a  
 "Redox" potential, 1546  
 Redox potentials, detn., 156c  
 — potentiometric titration,  
 157c  
 — reduction process, 154(2)  
 — rH queried, 159a, *c*  
 — standard potenMa", 155(2)  
 Reformed gasoline, 339a  
 Reichert Value, 68a  
 Reichert-Meisbl Values, 31c  
 Reichert - Polenske - Kirsch  
 test, 31c, 66(2)  
 Resorcinol, 475(2)  
 Respiration and cytochrome,  
 164(2), 165a  
 Rhamnazin, 300c  
 Rhamnetin, 3002  
*Rhamnus altemus*, *R. species*,  
 3006  
 Riboflavin, 163c  
 Ricinoleic acid, 96, 13c  
 Ring compound Urge, 290(2)  
 Ritter-Kellner pulp, 219(2)  
 Rodent pests, 302c  
 Roller mills, 204c  
 Rosin, detn., 76c  
 — sizing, 221c  
 Rotation, molecular, 117a  
 Rotatory dispersion, 1176  
 Rotenone, 306(2)  
 Rubber seed oil, 26c, 27a  
 Russian-leather odour, 2916  
 "Rutger's 612?" 312c
- S
- "Sartolith," 628c  
 Safflower oil, 26(2), 276  
 Salmon fat, 66  
 Salt hydrates, 4476  
 Salts, preparation, 450a, 454(2),  
 4556  
 —, separation, 448c  
 Satin White, 630c, 643(2)  
 Scarlet Chromes, 635a  
 Sea-flares, 514(2), 5166  
 Seal blubber oil, 36a  
 Sea water contamination detn.,  
 58a  
 Seed-fats, component acids,  
 8c, 15(2), 176 *et seq.*  
 "Sequestering" Ga ions,  
 612d, 513a  
 Sesame oil, 256, 536, 55c  
 Shade of pigments, 624c  
 Shea fat, 20a, 6  
 Sheep body fat, 296, 30a  
 "Shortenings," 23a, 27a  
 Silica in paints, 630(2)  
 Skatole, 290a  
 Slate powder, 6310  
 "Soaking" in reforming gaso-  
 line, 332a  
 Sodium carbonate and hydro-  
 gen peroxide, 2956  
 — metaphosphate glasses, 510a,  
 513a

- Sodium tetrapotfphosphate, 5126, 513tf  
 Soil-particle size, A.3.T.M., 240ft.  
 Solvent extraction\* of petroleum fractions, 3706  
 Soya-bean oil, 27a, 20a, 53c, 5c  
 Specific rotation, 117a  
 — surface, 243a  
 Spectra, absorption, atomic effects, 627a, 533a  
 —, appearance, 533b  
 —, structure of absorption, 5316  
 Spermaceti, 36c  
 Sperm blubber oil, 36c  
 — hejd oil, 36c  
 Sperm-whale oil, 66, 366  
 Squalene, 35ft  
 Stainers, 623c  
 Stannic oxide, \*20c  
 Stearic acid, distribution, 9a, 10c  
<sup>11</sup> Stearins " (stearines), 20a, c, 40c, 53c, d  
*Stillingia sebifera*, 166, 26c  
 Stokes' law, 230a\*  
 Stoving materials, 204a  
 Strontium white, 6306  
 Styrene from benzene, 3486  
 Sugden's paper, 226a  
 Sugar palms, 211d  
 Sulphate woodpulp, 218(2)  
 Sulphite wdflrpulp, 2106  
 Sulphur, detn. in oils, 566, 50c  
 Sulphuric acid treatment, 366(2)  
 Sunflower oil, 256, 56c  
 Superphosphate, 483a  
 Sweetening, 3606  
 Swelling pressure, 136a  
 Synthetic rubbers, 307c
- T**
- Tariric acid, 06, 13a  
 Teaseed oil adulterant, 22a, 64a, 72(2)  
 —, characteristics, 22a, 53c, 56c, 64a, 72(2)  
 " *Technicolor*, " 581c, 583a  
 Teleostid fish oil, 6a  
 Tendering of dyed cotton, 501r  
 Terephthalic acid, 597d\ 616<2  
 i-Terpineol, 2826  
 Terpinyl acetate, 280a  
 " *Terylene*, " 617a  
 J<sup>B</sup>-Tetradecenoio (myristoleic) acid, 12a, 37a  
 Tetraethyl-lead, 381a  
 Tetrahydrogen diphosphide, 510if  
 1:2:3:5 - Tetrahydroxybenzene, 478(2)  
 Thebaine, 103a, 6, c, 108(2)  
 " Thebolactic acid, " 115(2)  
*Theobroma cacao*, 166  
 Thermal reforming, 330a  
 Thinners, 2046  
 « *Thiohol* " rubber, 307c
- Threshold treatment, 5146  
 Thymol, 474c  
 Thyroid, control of iodine in, 660a  
 Thyrotropic hormone, 659a"  
 Tin oxide, stannic oxide, 620c  
 Tint of pigments, 624c  
 Titanium oxide, 628c  
 — o-peroxy-acid, 203c  
 — peroxides, 2036  
 Toddy, ^ 12a  
 p-Tolualdehyde, 284(2)  
 Toluene from petroleum, 356c  
 Tone of pigments, 624c  
 Tonka bean oil, 23a  
 Tractor fuel, 387c  
 Treating petroleum distillates, 360d  
 Triacetof peroxide, 208c  
 J<sup>n</sup>-Tridepenoic (gorlic) acid, 126, 13a  
 Triphenioxazine dyes, 152a  
 Triptane motor fuel, 383c  
 Tritopine, 113d  
 Tucuma fat, 176  
 'Bung tfril, characteristics (see also Elffioleic acid), 14c, 27(2), 56c  
 — gel, 50a  
 —, optical properties, 2a\*, 276  
 —, polymerisation tests, 73(2)  
 Turkey Red 011/516  
 Turpentine, 80(2)  
 —, Chian, 80(2)  
 —, Venice, 80(2)  
 Tyrosinase, 166c
- U**
- " *Überpannung*, " 142d  
 Ultramicroscope, 230c  
 n-Undecaldehyde, 284a  
 Undercoatings, 206a  
 " Unsaponifiable constituents, " 16, 63a  
 Unsaturation detn., 606  
 —, mean, expression for, 35a  
 Uranium, 657(2)
- V**
- VI flying bomb, 384(2)  
 V2 rocket, 182a, 385a  
 Vaccenic acid, 126, 20(2)  
 isoValeric acid, 6c  
 Vanillin, 2856  
 Varnish, short- or long-oil, 203(2)  
 Vegetable parchment, 231(2)  
 Vellum, 2316  
 " *Velteol* 1068, " 312a  
 Verdigris, 630a  
 " *Veritair* 482c  
 Vermilion, 636c  
 " *Vidane*, " 356(2)  
 Violet, Modern, 181(2)  
 Virago of indicators, 424c  
 " *V&anex*, " 3526, 307(2)
- Vitamin - *Bj* pyrophosphoric ester, 1656  
 Vitamin-Ba, 163(2)  
 Vitamin-^, 25a, 75a, 474c  
 P-Vitamin, 201a  
 Vitamins-^, and -D, Id, 34c, 356, 74c  
 Vulcanised fibre, 232(2)
- W**
- Walnut oil, 26(2)  
 Water-softening with meta- and poly-phosphates, 513a, 514c  
 " Wax distillate, " 404a  
 Wax esters, la, 6c, 36c  
 Weak acid and strong base, 421c  
 Werner-Pfleiderer mill, 205a  
 Whale blubber oil, 35c  
 — liver oil, 35d  
 — milk fat, 36a  
 — oil, 66, 35a, 53c, 54c  
 —, Antarctic, 366  
 —, hydrogenated, 366, c  
 Wheat-germ oil, 25a  
 Whiter Aluminium, 643c  
 —, Chinese, 627c  
 —, lead, 625(2), 6266  
 —, sublimed, 627a  
 —, toxicity, 626(2)  
 —, mineral, 6306  
 —, Paris, 630c  
 —, Pattinson's, 6276  
 Whiting, 630c  
 Willesden canvas, 233a  
 Winter green, oil of, 288c  
 Wool " fat, " *Wool grease*, *Wool grease*, 31a
- X**
- <sup>11</sup> Xanthaline, " 113a  
 Xanthoshamoln, 300(2)  
 m-Xylenol, 478c  
 Xylenols, 4736
- Y**
- Yellow, Antimony, 636c  
 —, Cadmium, 636a  
 —, Kings, or arsenic, 6366  
 —, Naples, 6366  
 Yellows, ferrite, 633c
- Z**
- Zinc as pigment, 641(2)  
 — sulphide, 6%  
 — oxide, 627c  
 Zirconium peroxysulphate, 203c  
 Cooxnaric acid, see J<sup>o</sup>-feexadecenoic acid